



Fall 2009 Semester CALENDAR

AVIATION FIRST DAY OF INSTRUCTION

Wed, Aug 12

FALL SEMESTER BEGINS

Tues, Sept 1

Aviation Maintenance Technology classes begin August 12.

LABOR DAY HOLIDAY

Mon, Sept 7

No day, evening or weekend classes.

LAST DAY TO ADD A SEMESTER-LONG COURSE or to OBTAIN AN ADD CODE

Tues, Sept 8

from an instructor unless class is open entry or late-start (see list on page 57). Online registration open until 11:59 p.m. No in-person registration on the main campus after 7 pm. Use online services.

LAST DAY TO DROP WITH A REFUND

Tues, Sept 15

See page 6.

"NRS" DEADLINE

Thurs, Oct 1

"No Record Shown". Semester-long courses dropped by this date do not appear on the student's permanent record. The "NRS" deadline for a short-term course is 30% of the class meetings.

DEADLINE FOR SELECTING GRADING OPTION

Thurs, Oct 1

Last day to select the Pass/No pass grade option for designated, semester-long courses.

FALL GRADUATION PETITIONS DUE

Mon, Oct 12

See a counselor to complete a petition to graduate at the end of the fall semester.

VETERANS' DAY HOLIDAY

Fri, Nov 13

No day or evening classes.

"W" DEADLINE

Fri, Nov 20

Semester-long courses dropped by this date appear on the student's permanent record with a notation of "W" for withdrawn. The "W" deadline for a short-term course is 75% of the course meetings.

THANKSGIVING HOLIDAY

Thurs-Sun, Nov 26-29

No day, evening or weekend classes.

TRANSFERRING STUDENTS

Mon, Dec 14

Students transferring to a CSU or UC campus in the spring should file a request for a transcript and GE or IGETC certification from the Admissions and Records Office by this date.

FINAL EXAMS

Sun-Sat, Dec 13-19

LAST DAY OF SEMESTER

Sat, Dec 19

FINAL GRADES AVAILABLE ONLINE

Fri, Jan 8, 2010

Grades available online at www.gavilan.edu (click on the Self-Service Banner icon)

OFFICIAL TRANSCRIPTS AVAILABLE

Mon, Jan 25, 2010

Official transcripts will include fall grades as of this date. File requests for official transcripts, IGETC and CSU general education certifications by Monday, December 14th if you are transferring to a 4-year university in the fall. Unofficial grades available online (www.gavilan.edu)

Degrees Currently Offered

by Gavilan College

Associate of Arts

Administration of Justice

Art

Business

Child Development

Communication Studies

Fine Arts

Language Arts

Liberal Arts *various emphasis areas*

Media Arts

Music

Physical Education

Social Science

Spanish

Theatre Arts

Associate of Science

Aviation Maintenance Technology

Biological Science

Business: Economics Option

Computer Graphics & Design

Computer Science & Information Systems

Cosmetology

Digital Media

Engineering & Physical Science

Health Science

Mathematics

Nursing (LVN/RN)

Getting Started

You are eligible to ATTEND GAVILAN COLLEGE if:

- ◆ You are a high school graduate or
- ◆ You have passed the GED or the California High School Proficiency exam
- ◆ You are 18 years of age or older
- ◆ You are currently enrolled in high school. High School students may enroll with Special Student Status by completing a High School Contract form.

PLACEMENT/ASSESSMENT testing will help ensure that students are enrolled in courses that match their abilities in language and computational skills. Students must have completed the eighth grade to be eligible for assessment services. Placement scores, together with other indicators of a student's abilities, are used by counselors to determine appropriate course placements.

If you have attended another college and completed math and English courses within the past two years, you do not need Gavilan's placement assessment unless you wish to take it or it is required by your major.

See a COUNSELOR if:

- ◆ you are a first time student planning to transfer
- ◆ you are a first time student planning to obtain an AA/AS degree
- ◆ you are undecided about a major
- ◆ you are a high school contract student
- ◆ you are an academic probation student or in a "disqualified" status
- ◆ you are an international student
- ◆ you are taking over 17.99 units (spring/fall) or over 5.99 units (summer)
- ◆ you have completed prerequisite courses at another college
- ◆ your class has a prerequisite that was not successfully completed at Gavilan

ADDING & DROPPING COURSES

Students may add and/or drop courses

- **Online** (Click on the Self-Service Banner icon at www.gavilan.edu).
- **In person** on the main campus or at the Morgan Hill or Hollister sites.

A student who stops attending a course and does not officially drop is *not* automatically dropped by the instructor and may receive a final grade of "F".

CLASS CONFLICTS

In the event of a class conflict, students must **FIRST** receive written approval from instructor(s) noting that they are aware there is a class conflict and how work/time will be made up. The plan must then be reviewed and approved by either the Vice President of Student Services or the Vice President of Instruction.

ADD CODES

are obtained from an instructor during late registration for closed (full) classes.

They must be used within 48 hours and no later than 11:59 pm on Tuesday, Sept. 8 online or by 7 pm in person.

In order to be exempt from assessment and orientation you must:

- ◆ have an AA degree or higher *or*
- ◆ have accumulated fewer than 12 units in transfer courses *or*
- ◆ be presently enrolled in fewer than six units *or*
- ◆ not plan to earn a certificate or degree.

Opt out by completing a waiver form at the Admissions & Records Office. Doing this will prevent you from participating in priority/early registration.

New Students Registration Checklist

- 1) APPLICATION** File at least 72 hours before taking the Placement/Assessment test. Go to www.gavilan.edu and click on the link for Gavilan's online application.
- 2) PLACEMENT/ASSESSMENT TEST** Sign up in person or by calling (408) 846-4992 or (408) 846-4954.
 - a. If you have attended another college you may submit placement test scores from that college to a counselor for evaluation.
 - b. Results are posted approximately 24 hours after test completion.
 - c. If you do not dispute the results of your placement exams, you may register for classes without seeing a counselor.
- 3) ORIENTATION** online or in person. Sign up in person or by calling (408) 846-4954.
- 4) REQUEST A TRANSCRIPT** from your high school if you graduated within the past five years and have not yet attended college. Request a transcript from any colleges you have attended.
- 5) SEE A COUNSELOR**
- 6) REGISTER FOR CLASSES** go online to www.gavilan.edu and click on Self-Service Banner. Create your Gavilan ID number and select a PIN. Register!
- 7) PAY FEES** in person or Online.

You may be eligible for Financial Aid.

Visit the Financial Aid office (SC 124) or go to www.gavilan.edu/financial on the web.



OUR MISSION *In an environment that cultivates creativity, stimulates curiosity and emphasizes student learning, Gavilan College serves its community by providing high quality educational and support services that prepare students for transfer, technical and public service careers, life-long learning and participation in a diverse global society.*

ALTERNATE FORMATS:

The Gavilan College Schedule of Classes is available in alternate media formats. Contact the Disability Resource Center (408-848-4865) or the Office of the Vice President of Student Services (408-848-4738).

FORMAS ALTERNATIVAS:

El Horario de Clases del Colegio Gavilán está disponible en formato de medios alternos.

Por favor de contactar El Centro de Recursos para Discapacitados (DRC) (408-848-4865) o la Oficina del Vicepresidente de Servicios de Estudiante (408-848-4738).

ACCURACY STATEMENT: The Gavilan Joint Community College District and Gavilan College have made every reasonable effort to ensure that the 2009 Summer/Fall Class Schedule is accurate. Courses and programs that are offered, along with other information in the schedule, are subject to change without notice by the Gavilan College administration for reasons related to student enrollment, level of financial support, or for any other reason, at the discretion of the district and the college. The district and college further reserve the right to add to, amend, or repeal any of its rules, regulations, policies, and procedures, consistent with applicable laws.

Welcome to Gavilan College.



As a state-funded agency, Gavilan College has certainly been cognizant of the current tough economic times. Fortunately, the budget compromise reached by the legislature and governor recognizes the important contributions Community Colleges make in helping California's economy grow.

Community College enrollment levels are up across the state, as unemployed workers return to college for education and retraining, and university-bound students save money by completing their lower-division coursework at community colleges. At Gavilan College, Spring enrollment is up 17%, vs. 9.5% statewide, continuing a three-year trend of double-digit enrollment growth.

Although there are cuts in the state budget, (such as eliminating the 0.68 % COLA for the current year) Gavilan College remains in a strong financial position, thanks to prudent and conservative budgeting and the participation of staff, students and faculty in an Expenditure Reduction Task Force. Through the work of the Task Force, over \$860,000 in budget reductions have been identified and accepted for the current year, and additional reductions have been identified for 2009-10. No staff will be laid off, and students will not be turned away to achieve these reductions.

We continue to implement Measure E – completing the purchase of land for two future campuses in Coyote Valley and San Benito County. Renovations on four main campus buildings will be completed this year. To accommodate all of the additional students seeking higher education, we are adding more portable structures and seeking additional space to rent throughout the district.

We are proud to be your College of Choice.

Superintendent/President
Steve Kinsella

Gavilan Joint Community College District

BOARD OF TRUSTEES

Tom Breen, *San Benito County*
B.S., J.D., *Santa Clara University*

Kent Child, *San Benito County*
A.A., *College of San Mateo*; B.A., M.A., *San Jose State University*

Mark Dover, *Gilroy*
B.S., M.A., *San Jose State University*

Laura Perry, Esq., *Morgan Hill*
A.A., *Gavilan College*, B.S., *San Jose State University*;
J.D., *Santa Clara University*

Elvira Robinson, Esq., *San Benito County*
B.A., J.D., *Santa Clara University*

Deb Smith, *Gilroy*
B.S., *University of Phoenix*

Mike Davenport, *Morgan Hill*
B.S., *Jacksonville University*, M.S., *National University*

Vacant, *Jovana McGraw*

ADMINISTRATORS

Steven M. Kinsella, D.B.A., C.P.A.
Superintendent/President

Victor Krimsley, Ph.D.
Interim Vice President of Instructional Services

Joseph Keeler, C.P.A.
Vice President of Administrative Services

John Pruitt
Vice President of Student Services

Fran Lozano
Dean of Liberal Arts and Sciences

Sherrean Carr
Dean of Technical and Public Services

Ron Hannon
Dean of Physical Education and Athletics

Fran Lopez
Associate Dean of Disability Resource Center

Rachel Perez
Associate Dean of Community Development/Grants Management

Anne Ratto
Associate Dean of EOPS/CalWORKs and CARE

GAVILAN COLLEGE LOCATIONS:

Gilroy Main Campus

5055 Santa Teresa Blvd.
 Gilroy, CA 95020
 408-848-4800

Morgan Hill Community Site

Gavilan College Building
 17060 Monterey Road
 Morgan Hill, CA 95037
 408-782-2873

Hollister, Briggs Bldg.

365 Fourth St.
 Hollister, CA 95023
 831-636-3783

Hollister Airport

490 Skylane Drive
 Hollister, CA 95023
 831-637-1151

CONTENTS

How to Register for Fall Classes inside front

Getting Started 1

Administrators, Board of Trustees 2

Spring Semester Calendar 4

How to Use the Schedule 5

Fees. 6

Financial Aid 7-8

Matriculation 9-10
 Assessment, Orientation, Counseling Services

High School Students 11-14
 High Step Program; Transfer Institute; High School Students: Concurrent Enrollment, Articulation Agreements, Gilroy Early College Academy, Registration Checklist, Recommended Math Placements

Student Services 15-16
 Basic Skills, CalWORKs, CARE, Career/Transfer Resource Center, Child Development Center/Preschool, Disability Resource Center (DRC), Extended Opportunity Programs & Services (EOPS), First-Year Experience, Health Services, Outreach and Recruitment Services, Puente, Student-to-Student Mediation, TRIO Student Support Services, Veteran Affairs Benefits

General Education Pattern 17

Instructional Support and Labs 18-19
 Bookstore, DRC Labs, English as a Second Language (ESL) Lab, Learning Communities, Library, Math Lab, MESA, Reading Lab, Service Learning, Transfer Institute, Tutoring Center, Writing Center

Transfer 19-25
 Transfer Credit, Variable Topics Courses, Transfer Services, Transfer Agreements (TAAs), Articulation Agreements, Advanced Placement, California Articulation Numbers (CAN), Intersegmental General Education Transfer Curriculum (IGETC), Career/Transfer Resource Center, IGETC Pattern, CSU Breadth Pattern

General Information 26
 Attendance, Advisories, Campus Safety and Crime Statistics, Course Repetition, Pass/No Pass, Letter Grade Option, Prerequisites and Co-requisites, Transcripts, Withdrawal

Policies and Procedures 27-28
 Academic Freedom, Disabilities, Discrimination, Drug Free Schools and Campuses Act, Family Educational Rights and Privacy, Open Enrollment, Parking, Sexual Assault, Smoke-Free Buildings, Students' Problem Resolution Process, Title VI, Title IX and ADA-Section 504/508, Vocational English Skills, Grade Policy

Student Life 29
 Associated Student Body (ASB), Publications, Rho Alpha Mu/Honor Society, Theatre Productions, Clubs

Measure E update 30-31

Summer Session 32-57
 Registration/Calendar 32-34
 Distance Education Classes 35
 Hollister and Morgan Hill Classes 36
 Summer Credit Classes 37-54
 Summer Noncredit Classes 55-57

Fall Semester

Late-Start Class List 57

Gavilan Online & SJSU Telecourses 58-59

Hollister Classes 60-61

Morgan Hill Classes 62-63

Service Learning 64

New Classes 65

Fall Classes 65-126

First Year Experience 96-97

Noncredit Classes 127-130

ROP Classes 131-133

Final Exam Schedule 133

English as a Second Language (ESL) Program . . 134

Información en Español 134-137

Forms 138-143
 Transfer Institute Application, Sample Schedule Chart, Application for Admission, High School Contract Form

Telephone Numbers 144

Map inside back cover

Check out Online Registration

go to www.gavilan.edu

and click on the Self-Service Banner Icon



Fall 2009 Semester CALENDAR

AVIATION FIRST DAY OF INSTRUCTION	Wed, Aug 12
FALL SEMESTER BEGINS Aviation Maintenance Technology classes begin August 12.	Tues, Sept 1
LABOR DAY HOLIDAY No day, evening or weekend classes.	Mon, Sept 7
LAST DAY TO ADD A SEMESTER-LONG COURSE or to OBTAIN AN ADD CODE from an instructor unless class is open entry or late-start (see list on page 57). Online registration open until 11:59 p.m. No in-person registration on the main campus after 7 pm. Use online services.	Tues, Sept 8
LAST DAY TO DROP WITH A REFUND See page 6.	Tues, Sept 15
“NRS” DEADLINE “No Record Shown”. Semester-long courses dropped by this date do not appear on the student’s permanent record. The “NRS” deadline for a short-term course is 30% of the class meetings.	Thurs, Oct 1
DEADLINE FOR SELECTING GRADING OPTION Last day to select the Pass/No pass grade option for designated, semester-long courses.	Thurs, Oct 1
FALL GRADUATION PETITIONS DUE See a counselor to complete a petition to graduate at the end of the fall semester.	Mon, Oct 12
VETERANS’ DAY HOLIDAY No day or evening classes.	Fri, Nov 13
“W” DEADLINE Semester-long courses dropped by this date appear on the student’s permanent record with a notation of “W” for withdrawn. The “W” deadline for a short-term course is 75% of the course meetings.	Fri, Nov 20
THANKSGIVING HOLIDAY No day, evening or weekend classes.	Thurs-Sun, Nov 26-29
TRANSFERRING STUDENTS Students transferring to a CSU or UC campus in the spring should file a request for a transcript and GE or IGETC certification from the Admissions and Records Office by this date.	Mon, Dec 14
FINAL EXAMS	Sun-Sat, Dec 13-19
LAST DAY OF SEMESTER	Sat, Dec 19
FINAL GRADES AVAILABLE ONLINE Grades available online at www.gavilan.edu (click on the Self-Service Banner icon)	Fri, Jan 8, 2010
OFFICIAL TRANSCRIPTS AVAILABLE Official transcripts will include fall grades as of this date. File requests for official transcripts, IGETC and CSU general education certifications by Monday, December 14th if you are transferring to a 4-year university in the fall. Unofficial grades available online (www.gavilan.edu)	Mon, Jan 25, 2010

Degrees Currently Offered by Gavilan College

Associate of Arts

- Administration of Justice
- Art
- Business
- Child Development
- Communication Studies
- Fine Arts
- Language Arts
- Liberal Arts *various emphasis areas*
- Media Arts
- Music
- Physical Education
- Social Science
- Spanish
- Theatre Arts

Associate of Science

- Aviation Maintenance Technology
- Biological Science
- Business: Economics Option
- Computer Graphics & Design
- Computer Science & Information Systems
- Cosmetology
- Digital Media
- Engineering & Physical Science
- Health Science
- Mathematics
- Nursing (LVN/RN)

HOW TO USE THIS SCHEDULE

Transferable
Includes:
CSU, UC
CSU-GE area designation
IGETC area designation
Gavilan AA/AS General Education designation
CAN #: For more information, refer to the General Education/ Course Credit Matrix on page 57 of the 2007-2009 Gavilan College Catalog.

Course Number

Course Title

Discipline

Prerequisites
(Refer to the College Catalog for Advisories for most courses. See page 130 of this schedule for an explanation of Advisories, Prerequisites and Co-requisites.)

Course Reference Number

Evening & weekend Courses
Listed in gray shade

Instructional Type
LEC Lecture
LAB Laboratory
L/L Lecture/Laboratory

Building/ Room

Semester Units

Class Hours per week

Instructor

BUSINESS

BUS 1 Fundamentals of Business
Transferable: CSU; UC; GAV AA/AS, D2
Course Description
REQUIRED/ADVISORY: Listed at the end of the course description

CRN	Type	Room	Instructor	Hrs.	Units	Days	Begin-End
10000	LEC	BU120	ROSS Y	3.20	3.0	TR	1250P 0210P
10100	LEC	BU119	STAFF	3.30	3.0	T	0600P 0905P

Off-Campus Sites

ANZ	Anzar High School, San Juan Bautista
AROMAS	Aromas School, 365 Vega St., Aromas
AV	Aviation, Hollister Airport, 490 Skylane Dr., Hollister
BROWN	Brownell Middle School, 7800 Carmel St., Gilroy
BURNET	Burnett Elementary School, 85 Tilton Ave., Morgan Hill
CALAVR	Calaveras Elementary, 85 Tilton Ave., Morgan Hill
CLR	Charles River Labs, Park Center Dr., Hollister
CRC	Centennial Recreation Ctr., 171 W. Edmundson Ave., Morgan Hill
CTC 1-4	GUSD/Gavilan Computer Technology Center on Murray Ave., Gilroy
EGLRIG	Eagle Ridge Golf Course, Santa Teresa Blvd., Gilroy
ELIOT	Eliot Elementary School, 475 Old Gilroy St., Gilroy
ELPORT	EI Portal, 277 I.O.O.F. Ave., Gilroy
ERGOLF	Eagle Ridge Golf Club, 2951 Club Dr., Gilroy
GABILN	Gabilan Hills Elementary, 901 Santa Ana Rd., Ste. 100, Hollister
GHS	Gilroy High School, 750 W 10th St., Gilroy
GSC	Gilroy Senior Center, 7371 Hanna Street, Gilroy
HARDIN	R. O. Hardin School, 881 Line St., Hollister
HHH	Hazel Hawkins Hospital, 911 Sunset Drive, Hollister
HOL	Hollister Briggs Bldg, 365 Fourth St. Hollister
HOLREC	Hollister Recreation, 300 West St., Hollister
HOPE-G	HOPE - 8855 Murray Ave., Gilroy
HOPE-H	HOPE - 2300 Technology Parkway, Hollister
HVME1	Hacienda Valley Mobile Estates, 275 Burnett Ave., Morgan Hill
JDA	Jovenes de Antaño, 300 West St., Hollister
JS	Jasmine Square, 16530 Monterey Rd., Morgan Hill
LOADCS	Live Oak Adult Day Services, 651 W. 6th St., Gilroy
LOHS	Live Oak High School, 1505 E. Main Ave., Morgan Hill
MHG	Morgan Hill Community Center, 17060 Monterey Rd., Morgan Hill
MV	Monterra Village, 900 Mantelli Dr., Gilroy
OMC	Ochoa Migrant Camp
PORTHL	Portuguese Hall, 695 Seventh St., Hollister
PLY	Morgan Hill Playhouse, Monterey Highway and Dunne, Morgan Hill
ROH	R.O. Hardin Elementary, 881 Line St., Hollister
SBHS	San Benito High School 1220 Monterey St., Hollister
SBCL	San Benito County Library, 470 5th St., Hollister
SBRAT	Sobrato High School, 401 Burnett Ave., Morgan Hill
SJBCC	San Juan Bautista Community Center, 10 San Jose St., San Juan Bautista.
SOL	Solorsano Middle School, 7121 Grenache Way, Gilroy
STF	St. Francis, 7950 Church St., Gilroy
SUNNY	Sunnyslope Elementary, 1475 Memorial Dr. Hollister
SVALLY	South Valley High School, 385 loof Ave., Gilroy
VG	Village Green, 7610 Isabella Way, Gilroy
VLA	Villa Luna Apartments, 850 Hillcrest Rd., Hollister
VPRI	Valley Pines Retirement Inn, 545 E. Main Ave., Morgan Hill
WEX	Work Experience
WM	Wheeler Manor, 651 W. 6th St., Gilroy
YMCA	Morgan Hill YMCA, 17666 Crest Ave., Morgan Hill

On-Campus Buildings

AL	Art Lecture
APE	Adaptive Physical Education
AR	Art
BOB	Business Offices
BU	Business
CD	Child Development Ctr.
CE	Community Ed
CH	Chemistry
CHP	Chapel
CJ	Classrooms
CO	Cosmetology
GY	Gym
HOB	Health Occupations Bldg.
HR	Human Resources
HRC	Human Resources Conference Room
HU	Humanities
LI	Library
LS	Life Science
MA	Mathematics
MAY	Mayock House
MP	Multipurpose Building
MU	Music Hall
OE	Classrooms
PB	Portable Building
PH	Physical Science
SC	Student Center
M	Maintenance
SS	Social Science
TH	Theatre

Schedule Legend

M	Monday
T	Tuesday
W	Wednesday
R	Thursday
F	Friday
S	Saturday
U	Sunday
ARR	Additional weekly hours required
FEX	Field Experience
TBA	to be arranged
TV	Telecourse
Wrk Ex	Work Experience

Gray shading indicates evening and weekend classes

Need a Book Loan?



With an ASB card you can apply for an ASB book loan (up to \$300) at the Financial Aid Office, room SC124.

Buy an ASB card at the Admissions & Records Office, room SC111.

Pay fees in person on the main campus or at either site, or online at www.gavilan.edu, Self-Service Banner.

In Person: cash, check, Mastercard, Visa

Online: American Express, MasterCard, Visa or Discover Card

Basic Fees

Per unit fee (California resident)	\$20
Per unit fee (non-resident)	\$214
Health Fee: fall/spring	\$15
summer	\$5
Campus Center Use Fee (fall & spring only) \$1 per unit to a maximum of \$5	
Student Representation Fee	\$1
Student Identification Card Fee: per semester	\$6

Parking Permits Required only on the Gilroy campus Monday-Friday

Day Permit (7 a.m. - 10 p.m.)	\$40
Day Permit with TANF/AFDC/SSI or Financial Aid.	\$20
Evening Permit (3 p.m. - 10 p.m.)	\$20
Summer	\$20

One-day permits may be purchased for 75 cents from the coin-operated machines located in parking lots A, E, H and at the south entrance to campus. Exact change is required.

Refunds Students must drop semester-long courses no later than Sept. 15 in order to receive a refund. Short-term courses must be dropped before 10% of the course meetings have passed. For one- or two-day courses, this date will occur before the start of the course.

Refunds of less than \$10 will remain on the student's account as a credit unless the Admissions and Records Office receives a Request for Refund form from the student.

Refund checks are mailed. Be sure your address is current (Online at www.gavilan.edu, Self-Service Banner) to ensure prompt delivery.

Student Health Fees Gavilan College is required to maintain health services and accident insurance for all students enrolled in credit classes. These services are covered by the \$15 health fee.

Student Representation Fee The Student Representation Fee is a \$1 per semester fee that students approved through a student body election. The student government (ASB) oversees and uses the fees to lobby and advocate for student issues and concerns at the state level. It also supports opportunities for students to attend leadership conferences on issues related to advocacy. Those students who do not wish to support these activities may request a refund directly from the ASB.

Fall 2009 Fee Schedule

TOTALS INCLUDE: \$20 per unit Enrollment Fee, \$194 Non-Resident Fee (if applicable), \$15 Health Fee, \$1 per unit Campus Center Use Fee (to a maximum of \$5), \$6 Student ID/Discount Card and \$1 Student Representation Fee.

Number of Units	California Resident	Non Resident Out-of-State	Number of Units	California Resident	Non Resident Out-of-State
0.5	32.50	129.50	9.5	217.00	2060.00
1.0	43.00	237.00	10.0	227.00	2167.00
1.5	53.50	344.50	10.5	237.00	2274.00
2.0	64.00	452.00	11.0	247.00	2381.00
2.5	74.50	559.50	11.5	257.00	2498.00
3.0	85.00	667.00	12.0	267.00	2595.00
3.5	95.50	774.50	12.5	277.00	2702.00
4.0	106.00	882.00	13.0	287.00	2809.00
4.5	116.50	989.50	13.5	297.00	2916.00
5.0	127.00	1097.00	14.0	307.00	3023.00
5.5	137.00	1204.00	14.5	317.00	3130.00
6.0	147.00	1311.00	15.0	327.00	3237.00
6.5	157.00	1418.00	15.5	337.00	3344.00
7.0	167.00	1525.00	16.0	347.00	3451.00
7.5	177.00	1632.00	16.5	357.00	3558.00
8.0	187.00	1739.00	17.0	367.00	3665.00
8.5	197.00	1846.00	17.5	377.00	3772.00
9.0	207.00	1953.00	18.0	387.00	3879.00

Courses With Additional Materials Fees

<u>COURSE</u>	<u>DESCRIPTION</u>	<u>FEE</u>
AH 32	BASIC CARD/LIFE SUP	\$12.00
AH 51	MEDICAL-SURGICAL NURSING	100.00
AH 53	MEDICAL-SURGICAL/MATERNAL-NEONATAL NURSING	100.00
AH 55	INTERACTIVE/MENTAL HEALTH NSG	\$100.00
GUID 1	SELF ASSESSMENT	\$12.00
PSYC 5	SELF ASSESSMENT	\$12.00

Fees payable to instructor or additional materials required

<u>COURSE</u>	<u>DESCRIPTION</u>	<u>FEE</u>
COS 200	BEGINNING COSMETOLOGY cosmetology kit	\$800 (approx.)
COS 201	INTERMEDIATE COSMETOLOGY manikin, pedicure kit and uniform	\$250 (approx.)
COS 202-203	ADV COS - PRACTICUM manikin, uniform and books	\$300 (approx.)
PE 17	GOLF facility use fee - details at first meeting	\$TBA
PE 20	BOWLING	\$1.50 per session
PE 39	FENCING	\$6.00 (payable to instructor)

Check out class offerings at our

Morgan Hill and Hollister sites.

Hollister: See pages 60-61

Morgan Hill: See pages 62-63

Student Identification/Discount Card

The purchase of the Student ID/Discount Card benefits both the individual student and the college at large. The fees are budgeted by the Associated Student Body to develop and support campus activities, educational programs, speakers, and cultural events. Cardholders also receive numerous on and off campus benefits including:

- Free admissions to college athletic events
- Community-wide discounts such as reduced movie admissions, restaurant discounts, gym, museums, computers and software discounts.
- Free bluebooks and scantrons in the college bookstore
- Eligibility for an ASB book loan (up to \$300)

ASB cards will be issued as part of the registration process. You may pay and have your picture taken in the Admissions and Records Office or at either site. Students who do not wish to purchase the ID/Discount Card must decline the card in writing.

Forms for requesting a waiver of this fee are available from the ASB Office, and the ASB Advisor's office (located in SC161). These forms must be turned in at the time of registration. Requests for refunds must be processed through the ASB Advisor.

California Nonresident Tuition Fee Exemption (AB540)

AB540, as required by California law, provides an exemption from payment of non-resident tuition for eligible non-immigrant students. To be eligible, a student must have attended a California high school for three full years and have graduated from a California high school or have received the equivalent of a California diploma (GED, CHESPE). The exemption does not grant residency status and the qualifying student may not be eligible for state aid programs such as BOG, EOPS or federal financial aid. The student must sign an affidavit affirming that he or she has filed or will file an application with INS to legalize his or her immigration status as soon as he or she is eligible to do so. Contact the Admissions & Records Office for more information.



Paying for College

APPLYING FOR FINANCIAL AID

Financial assistance with college expenses is available for students of all incomes.

FINANCIAL AID OFFICE

Room SC 124 408-848-4727

Open: Mon. - Thurs.: 8 am - 5 pm, Fri.: 8 am - 3 pm

Evening hours: Hours are extended during peak registration periods.

www.gavilan.edu/finaid/

Gavilan College participates in several financial aid programs that are designed to provide assistance to students with documented financial need. This aid is provided from several sources: federal, state and private agencies.

FAFSA Requirements:

Financial aid applicants must:

- demonstrate need according to the guidelines of each program.
- be a U.S. citizen or eligible non-citizen.
- be in good standing on a federal student loan (not default) or not owe a refund of student financial aid.
- demonstrate eligibility to benefit from higher education.
- be a regular student in an eligible program enrolling for the purpose of obtaining a degree or certificate.
- be registered (or formerly registered) with Selective Service (males only).
- maintain satisfactory academic progress.

What Financial Aid Applications do I complete?

BOG Fee Waiver Application: Students may qualify to have tuition fee of \$20 per unit waived if they are CA residents and meet certain criteria in any of the three BOG Fee Waiver methods. For BOG Fee Waiver applications and information on BOG Fee Waiver methods, please visit the Financial Aid webpage at <http://www.gavilan.edu/finaid/apply/waiver.html>. You may mail, fax or personally deliver your BOG Fee Waiver Application to the Financial Aid Office.

FAFSA (Free Application for Federal Student Aid): Determines your eligibility for federal and state grants as well as the fee waiver if you do not meet BOG Methods A or B guidelines and are a CA resident. The FAFSA can be completed through paper application or online at www.fafsa.ed.gov. Be sure to add the Gavilan school code of 001202 so that the Financial Aid Office can receive your processed FAFSA. Complete the:

- 2008-09 FAFSA: if you will attend the summer '09 term
- 2009-10 FAFSA: if you will attend the fall '09, spring '10 or summer '10 terms

Cal Grants Community college students who are California residents and have completed between 16 - 23 units at a CA community college are considered for a Cal Grant B through a competitive process. Interested students are required to have filed a 2009-10 FAFSA by September 2, 2009. For further information on the Cal Grant B Competitive process, visit us online at <http://www.gavilan.edu/finaid/grants.html>.

Scholarship Applications: The Financial Aid Office maintains a scholarship website where upcoming scholarship opportunities are posted, including scholarship applications. For current scholarship opportunities, visit us online at <http://www.gavilan.edu/finaid/scholarships/index.html>.

Financial Aid Programs

BOG FEE WAIVER: Board of Governor's Fee Waiver Program waives mandatory enrollment fees for eligible California residents. For complete details on three different methods to qualify for the BOG Fee Waiver, visit us at <http://www.gavilan.edu/finaid/apply/waiver.html>.

FEDERAL AND STATE GRANTS AVAILABLE AT GAVILAN COLLEGE:

- Federal Pell Grant
- Federal SEO Grant
- Federal Work Study Grant
- Cal Grant (B and C)
- Chafee Grant
- Child Development Grant
- EOPS Grant
- TRIO Grant
- CARE Grant

SATISFACTORY ACADEMIC PROGRESS (SAP) POLICY

The Gavilan College Financial Aid Office is required to measure your academic progress toward a certificate, associate, or transfer degree program. If you are not pursuing one of these programs, you are not eligible for financial aid. Your progress will be reviewed at least once per academic year.

If you had extenuating circumstances for your last term at Gavilan College and were placed on disqualification, you may submit an Appeal and SAP Quiz to the Financial Aid Office for consideration.

FEDERAL WORK-STUDY GRANT: Provides Gavilan College students with part-time employment while gaining valuable work experience. To be considered for federal work study, students are required to file the 2009-2010 FAFSA, indicate interested in Work Study on question 31 of FAFSA, meet program requirements, and have financial need. Funding for Federal Work Study program is limited, students are encouraged to file the 2009-10 FAFSA before 05/15/2009 to be considered for FWS. First FWS awards will be offered to eligible students on 06/30/2009.

SCHOLARSHIPS: Scholarships are awarded on the basis of academic achievement and/or financial need. Eligibility varies and is set by the scholarship donor. Private scholarship applications with various deadlines throughout the school year are available in the Financial Aid Office. See the Financial Aid website at www.gavilan.edu/finaid. We recommend you inquire about scholarships several times per semester as new scholarships are announced throughout the academic year as they become available.

VETERAN EDUCATION BENEFITS: Gavilan College offers special assistance to student veterans and children of disabled veterans. Students having questions pertaining to eligibility, benefits, application procedures and other veteran matters should contact the the VA Certifying Official at 408-848-4734. Forms are available on the Financial Aid website at: <http://www.gavilan.edu/finaid/va/forms.html>.

STUDENT LOANS: Gavilan College participates in the Federal Family Educational Loan Program. If you are interested in applying for a student loans, complete the FAFSA & attend an Entrance Loan Counseling Session. Applications for student loans are distributed at Loan Counseling Sessions.

LOOK US UP ONLINE AT WWW.GAVILAN.EDU/FINAID/

Complete the FAFSA at www.fafsa.ed.gov

Online financial planning guide & budget counseling at www.edwise.org

Check your Stafford loan status at www.elmresources.com

Online loan counseling at www.edfund.org

Selective service verification of enrollment at www.sss.gov

Apply for PIN at: www.pin.ed.gov

Ability to Benefit

NEED FINANCIAL AID BUT HAVE NO HIGH SCHOOL DIPLOMA?

Federal regulations require students who do not have a high school diploma, General Educational Development (GED) certificate, or California High School Proficiency Exam (CHSPE) and who are applying for financial aid, to take an Ability to Benefit assessment. If you have a high school diploma (or equivalent) from another country you are exempt.

THERE ARE THREE METHODS TO DEMONSTRATE ABILITY TO BENEFIT.

1. ASSET TESTING SCHEDULE FOR NATIVE ENGLISH SPEAKERS

The Ability to Benefit schedule can now be found on the Assessment web page. Go to www.gavilan.edu/admit/assess.html. Students are required to sign up for a testing session through the Financial Aid Office: 408-848-4727 (SC124). Times and locations subject to change and additional times may be added to the schedule. Confirm time and location with the Assessment Office in BU120B - 408-846-4992 prior to your scheduled appointment.

2. CELSA (COMBINED ENGLISH LANGUAGE SKILLS ASSESSMENT)

Students with limited English language skills who are enrolled in English as a Second Language (ESL) classes and do not have a high school diploma or GED and are applying for Financial Aid must take the CELSA assessment.

Call the Financial Aid Office (SC124) at 408-848-4727 for a referral. Then call the Assessment Office (BU 120B) at 408-846-4992 to schedule your appointment.

3. SUCCESSFUL COMPLETION OF 6 DEGREE APPLICABLE UNITS AT GAVILAN COLLEGE:

If you have successfully completed at least 6 units of degree applicable units, you have demonstrated the ability to benefit. Please make an appointment with a Gavilan College academic counselor for certification of unit completion.

Need to print out documents?

It's easy!

GoPrint

➤ ASB cards will be issued as part of the registration process. You may pay and have your picture taken in the Admissions and Records Office or at either site.

➤ Students who register online:
Purchase your ASB card and have your photo taken at the Admissions and Records office on the main campus or at either of the sites.

* Students with financial hardship can request assistance at Financial Aid, EOPS, TRIO, and MESA programs.

Get 100 free prints with purchase of an ASB (Associated Student Body) card!!

You can now use the GoPrint system to print documents at all of Gavilan College's computer labs. No need to fumble around with coins! Purchase either a GoPrint or ASB card and you're good to go!

GoPrint cards can be purchased and reloaded at the following GOPRINT pay stations: The Computer Place, Business Skills Lab, Student Center Vending Area, Math Lab and the Morgan Hill and Hollister Briggs Building computer labs.

Prints are \$.05 each.



Matriculation

ADMISSIONS • ASSESSMENT • ORIENTATION • COUNSELING • FOLLOW-UP

Matriculation is a series of services that Gavilan College commits to provide for you. The purpose is to help you identify your educational goals and successfully complete them.

Exemptions: Sometimes a student does not want to take advantage of the matriculation services. That is a right you have. In order to be exempt from assessment and orientation you must:

- have an AA degree or higher *or*
- have accumulated fewer than 12 units in transfer courses *or*
- be presently enrolled in fewer than six units *or*
- not plan to earn a certificate or degree.

Opt out by completing a waiver form at the Admissions & Records Office. Doing this will prevent you from participating in priority/early registration. You still have the right to use the other matriculation services. We encourage you to do so.

Assessment

Placement/assessment testing will help ensure that students are enrolled in courses that match their abilities in language and computational skills. Students must have completed the eighth grade to be eligible for assessment services. Placement scores, together with other indicators of a student's abilities, are used by counselors to recommend appropriate course placements. Register for the assessment at the Admissions & Records Office in the Student Center.

The assessment instruments used by Gavilan College for general assessment, the College Tests for English Placement (CTEP) and the Mathematics Diagnostic Testing Project (MDTP), are administered in English and are not intended for applicants to the English as a Second Language (ESL) program.

Sessions begin promptly at the stated time. **Check in begins one half hour prior to starting time.** No one will be admitted after the session has begun.

Assessment requires:

- Valid picture ID *
- Social security number required for scoring of exam
- The Assessment Center will provide pencils and pens for students during testing.
- No pagers or cell phones allowed in the testing room
- No watches allowed in the testing room.

* A valid picture ID includes a California Driver's License, California ID, Passport, Student Body Card, Military ID or Alien Registration Card. **Contact the Assessment Office (BU120B) or call 408-846-4992 if you do not have a valid ID.**

Re-Assessment Sessions:

Students who have previously taken the assessment test may re-test after 30 days. You may re-assess once per semester. Stop by the Assessment Office (BU120B) or call 408-846-4992 to confirm dates, times and locations.

Re-Assessment requires a copy of the student's previous test scores (test scores can be obtained from the Counseling Secretary - SC113).

Times and locations are subject to change. Additional times may be added. (Confirm dates and locations with the Admissions and Records Office or check online posting at www.gavilan.edu/admit/assess.html.)

All new ESL students must go through the ESL assessment process. See page 134.

Todos los nuevos estudiantes de ESL deben tomar el examen de nivelación de ESL. Consulte la página 134.

Orientation

Orientation is a required component of matriculation. It provides new students with an overview of instructional programs, support services, facilities and general graduation requirements. Completion will help students avoid making course choices that might complicate and lengthen the time required to reach their educational goals. This is also a time for us to welcome you to Gavilan College and for you to have an opportunity to meet other new students and staff.

Students should participate in an orientation session prior to meeting with a counselor.

Please phone 408-848-4723 for further details.

Orientation is completed online.

Click on the Orientation link on the Gavilan homepage - www.gavilan.edu to complete the orientation or contact the Counseling Office at 408-848-4723.

You may choose to not participate in orientation by completing a waiver form at the Admissions & Records Office. Doing this will prevent you from participating in priority (early) registration.

Looking for a Job?

Gavilan College has a new Career Center Web Interface

Career Connections

Free for Gavilan College students and community. New listings every week.

Set YOUR  Direction
Career/Transfer Resource Center

<http://www.gavilan.edu/transferctr>



Counseling

Gavilan College provides a staff of full and part-time professional counselors to assist students in meeting educational, career and life goals. Counseling is available to students who are uncertain about their plans for the future, who are experiencing difficulty in making important decisions, or who have any other personal or social concerns. In addition, counselors make referrals to many community agencies. Students may seek the assistance of any counselor at Gavilan.

See a counselor when you are:

- a first time student planning to transfer
- a first time student planning to obtain a AA/AS degree
- an undecided major
- a high school contract student
- an academic probation student
- taking over 17.99 units (spring/fall) or over 5.99 units (summer)
- have completed prerequisite courses at another college(s)
- an international student with an "F" Visa

Photo ID and Gavilan Student ID number are required to obtain counseling services.

Summer Counseling Hours

Gavilan Main Campus (walk in only)

May 26-June 26: M-Th 8:00 am to 4:30 pm; Fridays 8:00-11:30 am

June 29-July 3 CLOSED

July 6-August 21: M-Th 8:00 am to 4:30 pm; Fridays 8:00-11:30 am

August 24-August 27: M-Th 8:00 am to 5:30 pm; Fridays 8:00-11:30 am

Morgan Hill site (by appointment):

June 3: 8:00 am - 4:00 pm

June 10: 8:00 am - 4:00 pm

August 5: 8:00 am-4:00 pm

August 12: 8:00 am-4:00 pm

August 19: 8:00 am-4:00 pm

August 26: 8:00 am-4:00 pm

Hollister site (by appointment):

June 2: 8:00 am-4:00 pm

June 9: 8:00 am-4:00 pm

June 11: 8:00 am-4:00 pm

August 11: 8:00 am-4:00 pm

August 18: 8:00 am-4:00 pm

August 19: 8:00 am-4:00 pm

August 25: 8:00 am-4:00 pm

Fall Counseling Hours beginning Sept. 1

Gavilan Main Campus (walk in and appointments):

Walk-in: Mon-Fri 8:30 am-12:30 pm

Appointments: Mon-Thur 8:30 am - 7:30 pm

Fri 8:30 am - 3:30 pm

Morgan Hill site: Wednesday services available.

Call 408-782-2873 for an appointment.

Hollister Briggs Building site: Tuesday and Wednesday

services available. Call 831-636-3783 for an appointment.

GAVILAN COLLEGE
BOOKSTORE

Student Center

408-848-4742

- NEW BOOKS
- USED BOOKS (25% LESS THAN NEW)
- BOOK BUY BACK

GET OUT OF LINE ● GET ON LINE

Order your textbooks @ www.gavilan.BKSTR.com

RETURN Policy
 Refunds given UP TO SEVEN DAYS from start of class.
 Always have your receipt.
 Always make sure new books have not been written in.
 Shrink wrap sets should be returned with all enclosures.

We accept all major credit cards and checks with ID

HOURS
 Mon-Thurs 8:00 am - 7:00 pm
 Friday 8:00 am - 4:00 pm

Counselors by Department and Program

To schedule an appointment call the Counseling Secretary: 408-848-4723 or visit SC 113.

Dr. Jesus Olivas, <i>General Counseling/Articulation</i>	SC104	<u>Athletics:</u> Darlene Del Carmen	848-4880	GY118
Dr. Rosa Sharboneau, <i>General Counseling/Transfer</i>	SC119	<u>Basic Skills:</u> Michelle Foguet-Mendoza	848-4776	LI 157
Dr. Tim Lister, <i>General Counseling</i>	SC106	<u>DRC (Disability Resource Center):</u>		
Alex Lopez, <i>General Counseling</i>	SC107	Bruce Eastman	848-4865	LI117
Celia Marquez, <i>General Counseling/Puente Program</i>	SC105	Mary Denham		PB11
Jane Godley, <i>General Counseling</i>	SC107	<u>EOPS/CalWORKs (Extended Opportunity Programs and Services):</u>		
Farah Alam, <i>General Counseling</i>	SC107	Blanca Arteaga	848-4747	LI101A
Johanna Stewart, <i>General Counseling</i>	SC107b	Mari Garcia	848-4853	LI101A
Leslie Tenney, <i>General Counseling</i>	SC103	<u>MESA:</u> Sarah Aranyakul	848-4800, ext. 5606	PH117
		<u>TRIO:</u> Leticia Palacios	848-4707	LI109



HIGH STEP PROGRAM

High School Transfer Enrichment

Gavilan College, in conjunction with San Benito and Gilroy High Schools will offer courses accepted at any university (such as Political Science/Government and US History 1 and 2) each spring and fall semester at the high school campuses. All students are required to take the placement assessment prior to enrolling. All concurrent enrollment documents are required.

Please contact the Gavilan Assessment Office at 408-848-4992 or your high school counselor for more information and for a schedule of the placement assessment offered at the high school campuses.

High School Juniors and Seniors!

- Start college while enrolled in High School!
- In two years earn a maximum of 12 college units.
- Courses conveniently offered at the high school.
- Meet college and university requirements while still in high school.

The Benefits:

- It's FREE! The enrollment fee, campus center use fee, health fee and student representation fee are waived for High Step students.
- Experience college level work.
- Reduce four-year university expense.
- Advance academically.
- Become competitive in the four-year college and university admission process.

How to Register:

1. Take the Gavilan College assessment placement on your campus, at the Gavilan College Gilroy main campus or at the Morgan Hill or Hollister sites. You will complete a Gavilan application for admission during your assessment. Check out the assessment schedule on the web at www.gavilan.edu/admit/assess.html.
2. See your high school counselor or academic coordinator to determine eligibility (must have a cumulative 2.0 GPA and score at college level in reading, writing and math) and complete a Recommendation for Special Student Status form (High School Contract). All concurrent enrollment documents are required.
3. Ask your parent to sign the contract.
4. Turn all paperwork in to your high school counselor or academic coordinator.

Students must purchase their own textbooks. Check out the Gavilan College bookstore website at www.gavilan.bkstr.com. If you are unable to afford your textbook please see your high school principal.

Fall 2009 High Step class offered at:

San Benito High School: See class listings for course description.

GUID 1 Self-Assessment and Career Development

CRN #10813 SBHS-194 Cafierro J MW 0400-0520 Dates: 9/1 - 12/19

PSYC 5 Self-Assessment and Career Development

CRN #10830 SBHS-194 Cafierro J MW 0400-0520 Dates: 9/1 - 12/19

Courses offered at high school locations are open to any college-age student.



Applications for the fall 2009 Transfer Institute will be accepted beginning in May.

RAPID TRANSFER

for 1st time college freshmen *Apply early!*

What is it? The Transfer Institute (TI) is a Gavilan College program to guide you through the transfer process in the most efficient and effective means possible. As a part of the Transfer Institute you will save time and money by completing your freshman and sophomore years at Gavilan. You will also meet and get to know other students who share your goals and ambition.

Who is eligible?

- Recent high school graduates who are academically prepared for college level work.
- Students with placement in *college level English & Math 233*.
- Students must be 1st time college freshmen.

How do I apply?

1. Complete a Transfer Institute application.
2. Take a Gavilan College placement test.
3. Complete a Gavilan College admissions application and
4. Submit a High School transcript.

Benefits - Transfer Institute students receive:

- Early Registration.
- A dedicated counselor to guide and monitor you through the transfer process.
- Pre-transfer events and activities with four-year universities.
- Access to activities designed to ensure your success at Gavilan College.
- Assistance with the identification of and preparation for a college major.
- A two to three-year agreement guaranteeing your transfer goals.

For more information, call (408) 848-4723 or visit the website at www.gavilan.edu/transfer

A Transfer Institute application is printed on page 138.

Fall 2009 High Step classes offered at:

Gilroy High School: See class listings for course description.

CD 2 Early Child Development

CRN #10964 GHS-B1 Weiler J T 0330-0630 Dates: 9/1 - 12/19

CD 3 Child Growth and Development During the School Years

CRN #10966 GHS-B6 O'Leary M T 0330-0630 Dates: 9/1 - 12/19

PSYC 2 Early Child Development

CRN #10965 GHS-B1 Weiler J T 0330-0630 Dates: 9/1 - 12/19

PSYC 3 Child Growth and Development During the School Years

CRN #10967 GHS-B6 O'Leary M T 0330-0630 Dates: 9/1 - 12/19

Room assignments subject to change. Please call 408-846-4967 or check online to confirm the room.

High School Students

Concurrent Enrollment Procedures

Students whose age or class level is equal to grades 9-12 may attend Gavilan College as part-time or summer session students for advanced scholastic, vocational, or physical educational courses in accordance with the following procedures:

A **Special Student Status Contract Form** is required prior to registering for classes. A new form must be completed each semester. The form is available in local high school counseling offices, from the Gavilan College Admissions & Records Office and is included in this schedule. The form is also available online at http://www.gavilan.edu/admit/sp2006_high_school.pdf

Students enrolled in a public or private high school will be limited to a maximum of 6 transfer-level units for fall or spring semesters and 5 during the summer term (certain exceptions may be available for students enrolled in the TJ Owens Early College Academy). Students in good standing, with a minimum 2.0 GPA, must submit a current transcript, complete the placement assessment, and have the written approval of a parent or legal guardian, a high school counselor or principal and a Gavilan College counselor.

The campus center use fee, health fee, and student representation fee are waived for concurrently enrolled high school students.

Your Gavilan College Counseling Appointment

High school students must review their completed contract with a Gavilan College counselor. Counseling Services are available at the Gavilan main campus. See counseling hours (page 10) for dates and times.

Use the Registration Checklist (next page) to prepare for your meeting. For more information, call the Counseling secretary: 408-848-4723. A photo ID is required to obtain counseling services.

High Step students: Please refer to instructions for High Step students on page 11.

High School students may enroll in the following:

(All prerequisites apply)

- Fall and Spring Semesters: **Transfer level (courses numbered 1-99)**
- Summer Session: **All courses (transfer and non-transfer level)**

PLEASE NOTE: Additional rules may apply for students enrolled in the Dr. TJ Owens Gilroy Early College Academy (GECA)

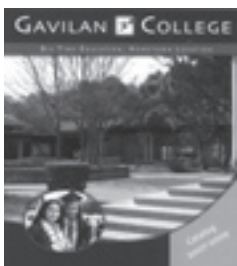

The College Catalog

contains a complete description of all Gavilan College courses, student policies, and services. It can be purchased for \$4.00 at the bookstore or viewed online at www.gavilan.edu/catalog

Course-to-Course Articulation Agreements* for High School Students

Gavilan College and District High Schools

HIGH SCHOOL COURSE	GAVILAN COLLEGE	GRADE CRITERIA
ANN SOBRATO HIGH SCHOOL		
Advanced Multi-Media	ART 113, CSIS 113, DM 113	B
Visual Communications	ART 107, CSIS 107, DM 107	B
ANZAR HIGH SCHOOL (Aromas-San Juan Bautista)		
Algebra	Math 205	A or B
Advanced Algebra	Math 233	A or B
CENTRAL HIGH SCHOOL (Continuation High School - Morgan Hill)		
Computer Business Applications	CSIS 1 & CSIS 126	C
GILROY HIGH SCHOOL		
Business and Marketing	BUS 1	C
Computer Business Applications	CSIS 1	B
Law Enforcement/ROP	AJ 10 (Intro to Admin/Justice)	A or B
Integrated Algebra 1 & 2	Math 205	A or B
Integrated Algebra 2 & 3	Math 233	A or B
Visual Communications	DM 77, ART 77, CSIS 77	B
LIVE OAK HIGH SCHOOL (Morgan Hill)		
Advanced Multi-Media	ART 113, CSIS 113, DM 113	B
Algebra I	Math 205	A or B
Algebra II	Math 233	A or B
Careers with Children	Child Development 1, 21	A or B
Graphic Technology	ART 77, CSIS 77, DM 77	B
Visual Communications	ART 107, CSIS 107, DM 107	B
MT. MADONNA HIGH SCHOOL (Continuation High School – Gilroy)		
Algebra I	Math 205	A or B
SAN ANDREAS HIGH SCHOOL (Continuation High School – Hollister)		
Computer Literacy	CSIS 1	C or better
SAN BENITO HIGH SCHOOL (Hollister)		
Advanced Multi-Media	ART 113, CSIS 113, DM 113	B
Algebra 1A or Algebra II	Math 205	A or B
Algebra 2A	Math 233	A or B
Business and Marketing	BUS 1	C
Careers with Children/ROP	Child Development 1, 21	B
Computer Accounting	Acct 103 (General Office)	C or better
Computer Business Applications	CSIS 1	C

*Articulation agreements currently being reviewed. Check Admissions for further information

All records of high school students attending Gavilan are protected by the Federal Educational Rights and Privacy Act (FERPA) and may not be released to anyone, including parents or guardians, without the written permission of the student.

New! Liberal Arts Associate's Degree Areas of Emphasis

Check out the updated Catalog online - www.gavilan.edu/catalog - click on Liberal Arts.

Attend High School at Gavilan College!



"Be Someone. Go Somewhere. Seek Excellence."

Dr. T.J. Owens Gilroy Early College Academy, located on the campus of Gavilan Community College, was established in 2006-07 as a partnership between the Gilroy Unified School District and Gavilan Community College and a grant from the Bill Gates Foundation. The program is structured to provide successful, challenging, and meaningful experiences for students identified as high ability who are not yet reaching their potential. Additionally, these students are typically the first in their family to attend and graduate from college. Students are offered not only the opportunity to earn a high school diploma by meeting the Gilroy Unified School District's A-G high school coursework, but they also take college courses for which they receive college units through dual enrollment. Students will experience a highly rigorous, college preparatory (Honors and AP) high school education, as well as take fully transferable college classes (up to 11 units a semester), for which they will receive both college and high school credit. Graduation in these for our five years may lead to attending a four-year university with two full years of college (60 units) completed. Students may earn an AA or AS degrees from Gavilan.

Acceptance to the Academy is based on a multiple-measures approach that involves an application packet, essay, personal interview, and Gavilan College assessment testing in both English and Mathematics. Applicants are not required to be currently enrolled in a Gilroy Unified school or live in the Gilroy Unified District. Students should have an overall GPA of 2.5 or higher, STAR scores in the "Proficient" range or above and the ability to read at or above the 9th grade level.

Applications are available online at www.gavilan.edu/geca, at any of the GUSD Middle Schools, or at the GECA office (PB-17) at Gavilan College. For more information you may call 408.846.4909 or visit our web site at www.gavilan.edu/geca.



Seniors! Plan ahead!

- Take the assessment and register for PUENTE before June!
- Placed in English 250 and want to transfer? Puente may be for you.
- Learn about Mexican American/Latino Literature.
- College visits in fall/spring.
- Attend a Transfer Conference.
- Receive extra support from a community mentor.
- On-going academic, career and personal counseling until you transfer!

Meet with Puente Counselor/Coordinator Celia Marquez.
Call 408-848-4723 to schedule an appointment.

High School Students Concurrent Enrollment

Registration Checklist

- #1 Apply.** Complete an application at least three working days before registering. Go to www.gavilan.edu and click on the link for Gavilan's online application.
- #2 Schedule and take an assessment placement test.** Sign up in person or call 408-846-4954 or 408-846-4992.
- #3 See your high school counselor.** Take your assessment test results and discuss possible courses. The course your counselor writes on the Special Student Status Contract Form is the course for which you will be enrolled, space permitting. Be sure the counselor signs your contract form. Directions to obtain the contract are listed in the concurrent enrollment section on page 12.
- #4 Get a copy of your current high school transcript** from the Registrar at your high school and attach it to your contract form. The transcript must show that you are in good standing and that you have a grade point average of at least 2.00.
- #5 Ask your parent or guardian to sign the contract.**
- #6 Bring your transcript and signed contract** to a Gavilan College counselor during the enrollment period for high school students.
- #7 Register for Gavilan classes.**
 - Enroll for a maximum of 6 semester units of transfer level courses during the fall and spring semesters or for 5 units of pre-collegiate or transfer courses during the summer term (certain exceptions may be available for students enrolled in the T.J. Owens Early College Academy)
 - Pay your fees.
 - Purchase a parking permit if you need one
 - Buy your books at the bookstore
- #8 Enjoy your class!** You're earning college credit.

For more information, see the concurrent enrollment section (page 12).

If you are enrolling in a High Step class, some steps may be facilitated by Gavilan College staff on your behalf.

Recommended Math Course Placements For Area High School Students

Gilroy High School

If you have completed take Gavilan course

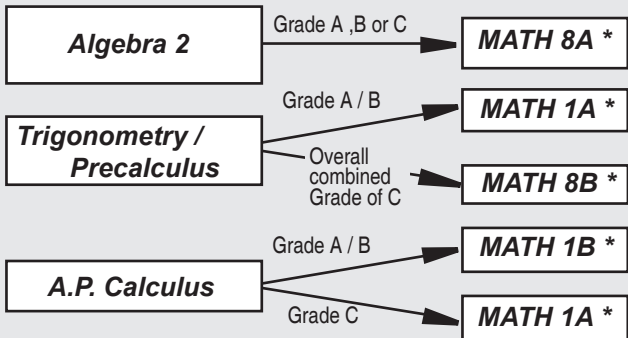

San Benito High School

If you have completed take Gavilan course

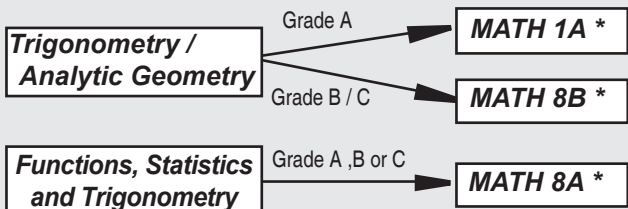

Anzar High School

If you have completed take Gavilan course

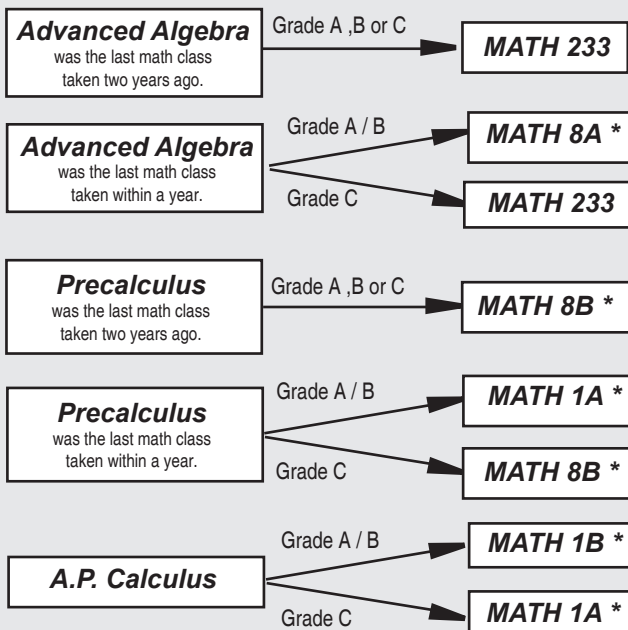

Live Oak High School

If you have completed take Gavilan course

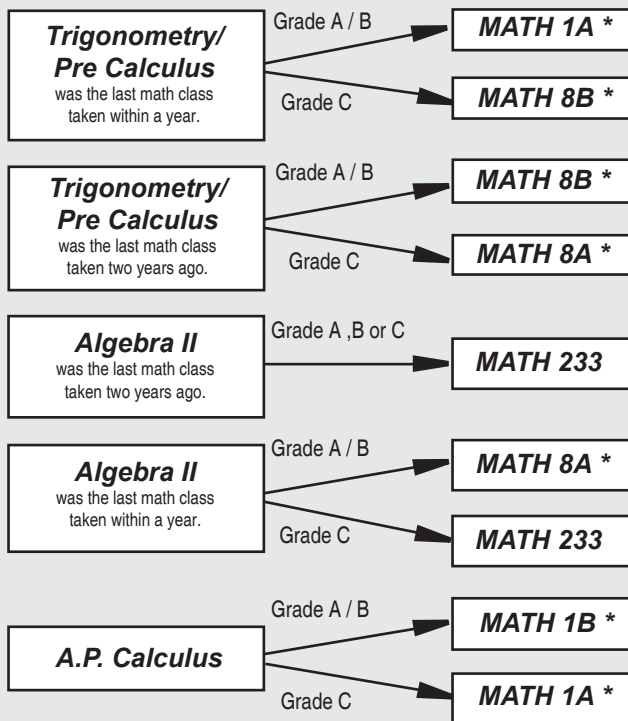

Multiple measures will be considered to determine your final course placement. Consult with a counselor to select the appropriate course.

* Students eligible for these courses are also eligible for Math 5, 6, 7, 12 and 14.

After School is Out...

Take a Class at GAVILAN!



Receive college credit.

Gavilan offers a selection of afternoon & evening classes at our three locations and selected high school campuses.

Student Services

Basic Skills The Basic Skills Network targets students who, based on their assessment test scores, are placed into pre-collegiate, non-transferable levels of English and/or Math courses and provides them with support and services to ensure they have every opportunity to be successful with their academic goals.

Students who require these pre-collegiate course(s) are identified and assisted with obtaining appropriate services and resources, on and off campus, that may enable them to become academically successful and on track to achieving their goals. Students are referred to the excellent categorical programs on campus such as DRC, EOPS, MESA, Puente and TRIO and those who do not qualify are offered one-on-one counseling services with a designated counselor

In-class workshops on topics such as study skills, time management, math “fear no more” and goal setting provide students with practical tools and strategies to be successful, and individualized counseling and an “early alert” system help to identify and resolve student issues early.

The Basic Skills Network strives to empower students and fosters student success and academic goal achievement within a nurturing, non-judgmental, confidence building environment.

CalWORKs CalWORKs serves students who receive public assistance to become self-sufficient through the provision of education, employment and supportive services. The occupational programs for CalWORKs students are linked to the demands of the local labor market and can assist students with a career track that will lead to a family-supporting income. The support services that CalWORKs provides include academic, personal and career counseling, textbooks, employment assistance and job placement and serves as a liaison with county departments of social services.

The CalWORKs staff is friendly and supportive and will work with students to help them reach their goals. The office is located in L101 A, next to the library and is open Monday through Friday, 8 a.m. to 5 p.m. Interested students may call 408-848-4740.

CARE The Cooperative Agencies Resources for Education (CARE) is a special program designed to assist single parents who attend or would like to attend Gavilan College. CARE is a joint effort among the Department of Social Services, EOPS and Gavilan College. To be eligible for CARE, a student must be at least 18 years of age, head of household single parent/grandparent receiving cash assistance from the Department of Social Services, have at least one child under 14 years of age and be eligible for EOPS.

Services provided include:

Transfer and vocational education and counseling, priority registration, academic tutoring, financial assistance with transportation, books, supplies, grants and other support services.

For additional information, call 408-848-4790 or visit the EOPS office located in L101 A & B.

Career/Transfer Resource Center The Career/Transfer Resource Center offers numerous resources to help in making career decisions, plan for college, obtain specialized training or enter an academic or vocational program at Gavilan College. Career-related services are available to currently enrolled students, prospective students, faculty, staff, and community members.

The computerized career guidance program, EUREKA, aids in researching occupations, identifying which colleges offer specific majors, and investigating

financial aid and scholarships. EUREKA (California Career Information System) contains information on hundreds of occupations, programs of study, financial aid, short-term training, colleges and universities, and scholarships.

Visit the Career/Transfer Center and log on to Career Connections, a job search website for employers and employees. We are located in the Student Center, SC 102. Make an appointment with the Career Center Specialist at the SARS kiosk in the Student Center or call 408-848-4818.

Child Development Center/Preschool The Child Development Center provides care for preschool children in two state-funded programs for families whose monthly income meets eligibility criteria. In addition, a fee based preschool program is available to all parents. These programs serve children with disabilities and special needs as well as children who are limited or non-English speaking. The Center is the only facility in Gilroy that is accredited by the National Association for the Education of Young Children (NAEYC)

The Center is located above parking lot C and is open Monday - Friday. For more information call 408-848-4815.

Disability Resource Center (DRC) DRC provides a variety of services and classes in an effort to equalize educational opportunities for students with disabilities as they move toward their educational or vocational goals.

Services include: Note taking • Academic, Career and Personal Counseling • Referral Services • Learning Skills Assessment • Vocational Preparation • Learning Skills Strategies Assistance • Registration Assistance • Mobility Assistance • Vocational Aptitude Testing • Multi-media Educational Aids • Sign Language Interpreting • Job Training and Placement • Individualized Accommodations • Alternate Media Services

DRC CLASSES OFFERED:

Guidance Courses:

Guid 530	Job Readiness
Guid 557	Learning Skills Assessment
Guid 558	Learning Skills Laboratory
Guid 560	Individualized Basic Skills Development
Guid 561	Writing Skills
Guid 562	Directed Study Lab in Arithmetic
Guid 563A/B	Directed Study Lab in Algebra
Guid 564	Directed Study Lab in Pre-Algebra

Adapted Physical Education:

PE 34/534	Adapted Aquatic Exercise
PE 35/535	Adapted Swimming for Total Fitness
PE 36/536	Adapted Physical Education
PE 38/538	Adapted Cardiovascular Conditioning and Training

Computer Science Classes:

CSIS 570	Computer Access Evaluation
CSIS 571	Computer Assisted Instruction
CSIS 572	Adaptive Computer Basics

Vocational Preparation: These programs are offered for students with developmental disabilities at three sites: Gavilan College, HOPE in Gilroy and HOPE in Hollister.

Students requiring accommodations or arrangements because of hearing, visual, or other disabilities should contact their instructor, counselor, or the Adapted Services Specialist at the Disability Resource Center located in LI 117. For more information call 408-848-4865.

Please help protect Gavilan's park-like setting by properly disposing of litter and recycling.



Health Insurance for students

Affordable year-round insurance is now available for community college students enrolled in a minimum of 9 units!

\$100 deductible per year (Visit Gavilan College's Health Nurse for a referral and the deductible is lowered to only \$50 per year!)

Visit the doctor of your choice.

Benefits include: hospitalization, emergency room visits, surgery, doctor's visits, treatment for mental and nervous conditions, prescription drug coverage, toll-free Nurse Advice Line.

For more information call 1-800-853-5899 or visit www.wellsfargo.com/studentinsurance, click on Comm.College League-Domestic

Sponsored by the Community College League of California

Extended Opportunity Programs & Services (EOPS)

Extended Opportunity Programs and Services provides access and support services for low-income students facing social, economic and educational challenges.

The EOPS Program services include:

Counseling: Academic, career and vocational counseling • Personal problem-solving and crisis intervention • Vocational interest testing • Four-year college transfer assistance • Field trips to major four-year colleges • Community agency and emergency referrals

Financial Assistance: grants • book vouchers

Specialized Workshops for facilitating student success

Other Services: student computer center • one-on-one tutoring • book lending service • priority registration

The EOPS office is located in L101 A & B in the library and is open Monday through Friday, 8 a.m. to 5 p.m. Students who are interested may call 408-848-4740.

First-Year Experience Gavilan College offers a program for "first-time," new students who want to strengthen their reading, writing and study skills while at the same time becoming familiar with the campus and its resources. Teachers and counselors work together to help students develop connections between the courses and their college experience. The goal is to help students build a strong foundation and place them on the road for college success. See classes on pages 96-97.

Health Services Gavilan College provides a full-time faculty/college nurse who provides health services, health information, health education events, health counseling and referrals in a quiet, confidential setting.

Students receive confidential, personal health counseling for a variety of health concerns. Health Services provides first aid treatment, blood pressure screening, tuberculin skin testing for students, HIV testing referrals, condoms and over-the-counter medications such as aspirin. Pamphlets and classes are available on nutrition, hepatitis, stress management, AIDS, suicide and other health topics. Health information is provided in small group settings. Referrals for health conditions including alcohol and drug intervention are available. Health Services provides first aid kits throughout the campus and at the satellite sites, responds as a member of a team to campus emergencies on the main campus and provides information regarding outside health insurance for the college student.

Health Services is a comprehensive "one stop" center for a variety of health services located in the Admissions Building (SC 118.) Services are free and available Monday - Friday on the main campus in Gilroy. For additional information call 408-848-4791.

Outreach and Recruitment Services The services of the Outreach and Recruitment Office are designed to familiarize the community with the variety of programs and services available at Gavilan College. We will schedule tours of the campus or visits to a specific department, or provide information on academic, vocational and transfer opportunities. Outreach and Recruitment will also arrange for representatives from Gavilan to make presentations at your school or event.

For further information or to schedule a workshop, presentation or tour, please contact Outreach Services at outreach@gavilan.edu or call (408) 846-4993. Office location: BU 123.

Puente The mission of the Puente Program is to increase the number of educationally underserved students who plan to transfer to four-year colleges and universities, earn degrees and return to the community as leaders and mentors to future generations. Puente is open to all students.

English Instruction: Puente students take two consecutive writing classes, English 250 (Practical Writing) and English 1A (Composition). These classes provide a supportive and stimulating environment for Puente students to build confidence in their writing skills through an exploration of the Mexican American/Latino experience.

Counseling: Puente students work closely with their Puente counselor until they graduate, exploring career options, developing an academic educational plan and identifying lifetime goals. Students visit University of California and California State University campuses and attend an annual Puente student transfer conference. All Puente students are also required to enroll in Guidance 6 (Life Skills for Higher Education) and Guidance 1 (Self-Assessment and Career Development).

Mentors: Each Puente student is matched with a mentor from the business or professional community. Mentors share with students their personal, academic and career experiences, and provide a window into "real-life" work environments. The network of trained Puente mentors provides many resources for the Puente students, their families, their colleges and their communities. If you are interested in more information please visit SC 105 or call 408-848-4807.

Student-to-Student Mediation Mediation services will provide students with an opportunity to problem-solve together in a safe environment. Trained student mediators will work with two or more students who are in conflict to reach mutually agreeable solutions. Mediation services are free and confidential. Students wishing to become mediators can register for Introduction to Conflict Resolution (Psychology 6).

To obtain mediation services for a dispute on campus, contact the Counseling Department at 408-848-4723.

Transfer Services See Career/Transfer Resource Center ad on page 21.

TRIO, Student Support Services is a federally funded program designed to assist 160 first generation, low-income, and/or disabled Gavilan College students as they prepare to obtain a two-year degree and/or transfer to a four-year university. TRIO provides additional services such as academic counseling, tutoring, book and laptop lending programs, cultural and social activities and university visits. TRIO is committed to increasing graduation and transfer rates by creating a "sense of place" for those students who sometimes feel isolated and disconnected during their college experience. If you are interested in more information please visit the TRIO Program in the Library (LI109) or call 408-846-4981.

Veteran Affairs Benefits Priority registration is granted to any member or former member of the Armed Forces of the United States who is within two years of leaving active duty.

Gavilan College recognizes credit and grants credit to veterans and reservists for service and training completed in the Armed Forces. Gavilan College reports as credit for prior training only those prior units that are required for the student's current objective at Gavilan College. Students having questions pertaining to eligibility for benefits, application procedures and other veteran matters should contact the Veteran Affairs official in the Financial Aid Office (SC124) or call 408-848-4727.

GENERAL EDUCATION RECIPROCIITY AGREEMENT The Gavilan Community College District has entered into a mutual agreement with seven other Community Colleges to accept the general education of these colleges. The participating colleges are Chabot College (Hayward), De Anza College (Cupertino), Evergreen Valley College (San Jose), Foothill College (Los Altos Hills), Gavilan College (Gilroy), Mission College (San Jose), Ohlone College (Fremont), San Jose City College (San Jose) and West Valley College (Saratoga).

Students who obtain a Certification of Completion of Associate Degree General Education or complete an associate degree at any of the participating colleges will have both their general education course work and graduation proficiencies accepted as completed at any one of the participating campuses.

GAVILAN COLLEGE		
ASSOCIATE'S DEGREE GENERAL EDUCATION REQUIREMENTS (2007-2008)		
<p>1. File a Petition to Graduate with the Admissions and Records Office by April 1 for Spring or Summer graduation, and by October 1 to graduate at the end of the Fall Semester. One petition must be filed for each Associate degree, Certificate of Completion or Award of Achievement the student expects to receive.</p> <p>2. Maintain a cumulative grade point average of 2.0 ("C") or higher for all work attempted and a grade of "C" or higher in each major or certificate courses.</p> <p>3. Complete a minimum of 18 units of coursework in a major. Specific major course requirements are listed in the college catalog.</p> <p>4. Complete a minimum of 60 semester units. Within the (60) unit requirement, the (9) units in Area A, and B-4 must be completed with a grade of "C" or better in each course. Complete the last 12 units, or a total of 48 units, at Gavilan College.</p> <p>NOTE: Effective fall of 2009, the new Gavilan College graduation requirements includes ENGL 1A (Area A2 of the A.A./A.S. Gavilan College General Education Pattern) and Math 233 (Area B4).</p>		
AREA A	AREA C	AREA E
<p>COMMUNICATION IN THE ENGLISH LANGUAGE One course from each of these three areas: 6 Semester Units</p> <p>A - 1 ORAL COMMUNICATION CMUN 1A, 5, 8, or 10</p> <p>A - 2 WRITTEN COMMUNICATION ENGL 1A Note: Students starting fall 2009 will need to complete ENGL 1A (Composition)</p> <p>A - 3 READING ENGL 260 or SSCI 270A or SSCI 270B with a grade of "C" or better, or demonstrate reading proficiency at the college level. (Competency may be verified by an approved test.)</p>	<p>ARTS, FOREIGN LANGUAGE LITERATURE AND PHILOSOPHY One course from each of these two areas: 5 Semester Units</p> <p>C - 1 FINE AND PERFORMING ARTS CMUN 2; HUM 10 or any Art, Journalism, Music or Theatre Arts course (other than Area C-2)</p> <p>C - 2 CULTURAL HISTORY, FOREIGN LANGUAGE, PHILOSOPHY ART 11, ART/HIST 21; ENGL 1B, 1C, 2A, 2B, 2C, 2E, 2F, 2H, 2J, 4A, 4B, 5A, 5B, 9A, 9B, 9C; HIST 1, 2, 3, 4A, 4B, 5, 6, 7A, 7B, 10, 12, 14; HUM 3, 4, 5, 10; JOUR/SOC 10, PHIL 1, 2, 3A, 3B, 4, 6A, 7A, 9; any foreign language.</p>	<p>LIFE-LONG UNDERSTANDING AND SELF-DEVELOPMENT 3 Semester Units</p> <p>1. One unit of Physical Education activity class or Intercollegiate Sport.</p> <p>2. Minimum of two units from: AH 3, 30, AH/BIO 11; CSIS 1, 2, 6, 8, 45, 51; GUID 1/PSYC 5, GUID 6, 200; HE 1, 2; PHIL 3B, 9; POLS/PSYC 27; PSYC/CD 2, 3; PSYC 41; SOC 21</p>
AREA B	AREA D	AREA F
<p>PHYSICAL UNIVERSE AND ITS LIFE FORMS One course from each of these three areas: 9 Semester Units The Physical or Life Science course must include a laboratory (indicated in BOLD.)</p> <p>B - 1 PHYSICAL SCIENCE ASTR 1; CHEM 1A, 1B, 12A, 12B, 30A, 30B; GEOG 1; GEOL 1, 13; PHYS 1, 2A, 2B, 4A, 4B, 4C; PSCI 1, 2</p> <p>B - 2 LIFE SCIENCE ANTH 1; ECOL 1; BIO 1, 4, 5, 7, 8, 9, 10, 13, 15</p> <p>B - 3 LABORATORY ACTIVITY Lab courses are bold in Areas B-1 and B-2 above.</p> <p>B - 4 MATHEMATICS Minimum of Math 233 or equivalent. (Competency may be verified by an approved test.) Note: Students starting fall 2009 will need to complete MATH 233 (Intermediate Algebra)</p>	<p>SOCIAL, POLITICAL, AND ECONOMIC INSTITUTIONS One course from area one and two courses from area two: 9 Semester Units</p> <p>D - 1 U.S. HISTORY AND POLITICAL INSTITUTIONS (3 units) One course from HIST 1, 2, 5 or POLS 1</p> <p>D - 2 BEHAVIORAL, ECONOMIC and SOCIAL SCIENCE (6 units) Two courses from AJ 6, 10; ANTH 2, 3, 5, 8, 9, 10; General Business 1; CMUN 4; ECON 1, 2, 10; GEOG 2; HIST 1, 2, 3, 4A, 4B, 5, 6, 10, 12, 14; JOUR/SOC 10; POLS 1, 3, 4; POLS/PHIL 12; POLS/PSYC/AJ/6; PSYC 1A, 1B; PSYC/CD 2, 3, 7; SOC 1A, 1B, 3, 4; SSCI 1</p>	<p>CULTURAL DIVERSITY 6 Semester Units 2 courses from the following list; courses listed under more than one area may be used, double counted, to satisfy other general education requirements.</p> <p>AH3, AH/BIO 11; ANTH 3, 5, 9, 10; ART 10A, 11, ART/HIST 21; CD/PSYC 7; CMUN 4; ENGL 2B, 2E, 2H; GEOG 2; HIST 3, 5, 6, 10, 12; PHIL 6; POLS 3, 4; SOC 3; SPAN 9A, 12A, 12B; THEA 1</p>

Instructional Support & Labs

Bookstore Visit the Gavilan Bookstore on the Gilroy main campus early. Used books may be available at reduced cost. See ad on page 10.

Disability Resource Center’s High Tech Center & Learning Skills Lab For more information, please refer to page 15.

English as a Second Language (ESL) Computer Lab
The ESL Program has its own dedicated computer lab with a variety of software programs for all levels and classes. Students, at their convenience, practice and enhance language learned in class. The ESL computer lab is located in the Business Building (BU119.) Call 408-848-4856 for more information.

Learning Communities In learning community courses, you work and study with others so you’ll be more successful in the course. Also, by linking two or more courses together, you’ll begin to see greater connections between the disciplines. Research shows that when you take a learning community course, you become a stronger student and do better in your other college courses.

Library The Gavilan College Library delivers an array of print and electronic resources to the college community. Augmenting the 60,000 title printed book collection are 19,000+ eBooks, and over 2,500 magazine titles, many available online in electronic databases. Recent additions include an extensive DVD, film and talking book collection. The Library staff prides itself on being a leader in information literacy projects and web-based instruction and has received several state grants supporting that effort. The Library faculty also teaches various courses on Internet use, and works in tandem with other faculty in planning and revising courses with an information literacy component.

The Library homepage at www.gavilan.edu/library/ provides an online catalog of our book collection, links to various class websites and key online resources. The Library is open from Monday-Thursday, from 8:00 am - 8:00 pm and Friday from 8:00 am - 3:00 pm. For more information call 848-4810 (Circulation) or 848-4806 (Reference.)

Math Lab The math lab provides a place for students to practice math skills and receive individualized help with math problems at every level, from Basic Mathematics to Calculus. Students can work with math instructors, the math lab assistant or other students. Computers in the lab provide tutorial software as well as math software for Geometry, Statistics and Calculus projects. The Math Lab is located in PH101. To download the daily schedule or for free math downloads, visit the website at <http://gavilan.edu/mathlab/>. For more information, call 408-848-4959.

MESA The MESA (Mathematics, Engineering, and Science Achievement) Undergraduate Program is a partnership between the University of California (UC) and California Community College Chancellor’s Office. The program provides services to qualified students who are 1) majoring in math and science based fields (ie Biology, Chemistry, Engineering etc.), and 2) planning to transfer to 4-year universities in order to graduate with baccalaureate degrees and have financial need and are first generation college students. Open to all eligible students, MESA emphasizes participation by educationally underserved students. MESA provides a study center, Academic Excellence Workshops, tutoring, university trips, academic advising, workshops and more. For more information go to www.gavilan.edu/mesa or call 408-846-4968.

Reading Lab The Reading Lab supports the needs of students in reading classes with a special emphasis upon the English as a Second Language (ESL) classes. For more information, call 408-846-4980 or visit the lab in the Library (LI200a.) The lab is open Monday through Thursday 8 am - 3 pm; Friday 8 am - 12 pm.

Service Learning at Gavilan In service learning classes, students work under supervision at a partner agency in the community for 10-40 hours a semester, and write reflective papers to connect the agency experience to their classroom learning. A number of Gavilan College departments have offered Service Learning for years, and a new AA degree in Social Science with a concentration on Community Studies will make Service Learning a key part of a major program at Gavilan. Service learning promotes civic engagement and academic excellence, and students participating benefit themselves and the community at the same time.

Why take a Service Learning class? You’ll have positive, meaningful and real experiences. Many students get better grades in SL classes than in non SL sections of the same classes. Some report success in investigating or discovering career options; most gain knowledge of themselves and their communities. Many practice invaluable workplace skills involving teamwork and citizenship and report deeper learning because the results are immediate and uncontrived. Service experiences are very often personally meaningful-many students become Lifelong Service Learners. And Service Learning is common at transfer colleges, particularly the CSUs and UCs.

What are you waiting for?! Sign up for a Service Learning class today!

Transfer Institute The Transfer Institute (TI) is a selective program designed for qualified students who want to transfer to a public or private university in two years. Recent high school graduates who are academically prepared for college level work and students with placement in college level English and math 233 or higher.

The Transfer Institute will guide the student through the transfer process in the most efficient and effective means possible. As a part of the Transfer Institute students will save time and money by completing the freshman and sophomore years at Gavilan College. Students will also meet and get to know other students who share their



LIBRARY DATABASES <http://www.gavilan.edu/library>

Discover the rich resources available with your Gavilan Library card. Whether for your term-paper or your interests, current and reliable materials specifically designed for Gavilan courses are available from the library databases. About a third of all the library materials are from “proprietary” databases. That means we pay for these materials on your behalf; they are not available to the public at large. About a million online magazine and newspaper articles cover a wide range of topics, e.g.

- elections and politics
- controversial issues
- literature
- history
- health
- psychology
- sciences
- photos and images

GET YOUR LIBRARY CARD NOW!

Your library card gives you access to library resources:

- access to computers in the library
- books, eBooks, reserve materials and more
- access to all electronic databases, on campus or from home

Students can get their library cards in person or online. Library cards are available to registered Gavilan students, staff and faculty, as well as community residents with a valid photo identification. Visit <http://www.gavilan.edu/library> for more information.

goals and ambitions. As a Transfer Institute student you will receive early registration, a dedicated counselor to guide and monitor you through the transfer process, pre-transfer events and activities with four-year universities, access to activities designed to ensure your success at Gavilan College, assistance with the identification of and preparation for a college major and a two to three-year agreement guaranteeing transfer goals.

A Transfer Institute application is on page 138 of this schedule of classes. Contact the Counseling Department at 408-848-4723 for more information.

Tutoring Services provides students with diverse academic needs a place to gather together to receive learning assistance. The basic philosophy of tutoring services is to assist students in the improvement of their learning skills and understanding of course content. This is accomplished by providing students with an opportunity to discuss processes and concepts, share ideas, give examples and practice, and summarize their findings in a collaborative environment. The goal of the tutoring services is to guide students to independent learning.

Day and evening tutoring services are free to all Gavilan College students. Tutoring is offered in two locations: the Tutoring Center (LI 116) and the Computer Place (LI 168). For more information visit www.gavilan.edu/tutor or call (408) 848-4838.

Writing Center The Gavilan College Writing Center fosters, celebrates and encourages writers. Specially trained student assistants help writers start and strengthen class assignments as well as poetry, short stories, lyrics, business letters and resumes. The center offers space for writing discussions, meeting, workshops and study groups. Special events include activities with acclaimed writers from our Visiting Writers and Scholars in Residence programs. The center collaborates with faculty to increase the likelihood of students' academic success, providing peer assistants for classes and labs and a variety of tools, strategies and approaches for writers. Call (408) 848-4811 or drop by the center in LI 120 (the library building) for more information. The center is open Monday-Thursday 8 am-6 pm (closed Mondays 2:30-3:30 pm) and Friday 8 am-2 pm. From 5-6 pm on Monday-Thursday find us in the library itself.

Transfer

Students planning to transfer to a four-year institution can generally complete the first two years of their college work at Gavilan College and enter the four-year institution with junior standing.

The requirements of universities vary. It is therefore advisable that students consult a counselor early in the semester for more detailed information about each university's specific requirements. *Due to recent changes in admissions policies at UCs and CSUs, working with a counselor is critical.*

Career/Transfer Resource Center The center is located in SC102. See ad (page 21) or call 408-848-4818 for more information.

Transfer Credit Official transcripts from institutions which are fully accredited by appropriate accrediting associations will be evaluated for transferable lower division coursework. Appropriate units and subject content will be applied to major and general education requirements to meet prerequisites or graduation requirements. Courses taken at other California Community Colleges, California State Universities or any University of California will be transferred to Gavilan with the same general education designation as that of the issuing institution.

Students who wish to transfer coursework from foreign institutions must submit official transcripts to a college-approved foreign evaluation service for translation and evaluation.

Coursework from a foreign institution cannot be used for certification to a four-year institution. Students should contact the institution to which they wish to transfer to inquire about the acceptance of foreign coursework.



Transfer Checklist

Are you preparing to transfer to a four year university? If so, planning now will guarantee a smooth and easy transition from Gavilan to the institution of your choice. Follow the recommended PLAN FOR SUCCESS:

First Year at Gavilan:

FALL SEMESTER

- Meet with a counselor and inform him/her of your intent to transfer.
- Request a current copy of the general education pattern you wish to follow (IGETC or CSU)
- Refer to the Gavilan catalog for course descriptions.
- Begin to investigate possible major choices.
- Develop an educational plan with a counselor.
- Request that all high school and college transcripts be sent to Gavilan.

SPRING SEMESTER

- Meet with counselor to discuss academic progress and major choice.
- Update educational plan to include major preparation courses.
- Consider participating in student clubs, student government, etc.
- Identify at least 3 universities and check the required major preparation.
- Determine eligibility for an Associates Degree from Gavilan.

Second Year at Gavilan:

FALL SEMESTER

- Meet with counselor to discuss course selections and to review educational plan.
- Verify completion of units, general education, and major preparation.
- Update educational plan, if necessary.
- Apply for scholarships and financial aid.
- Apply for college admissions.

SPRING SEMESTER

- Submit a Gavilan graduation petition.
- Read all of your correspondence from universities.
- Follow university instructions and meet deadlines.
- Keep copies of all correspondence
- Send official transcript showing work completed and courses in progress for spring.
- At the end of the semester, request two copies of your final transcripts (spring grades included) and a G.E. certification. One copy is sent to the university that you plan to attend and the second copy is for you to keep for your personal record.

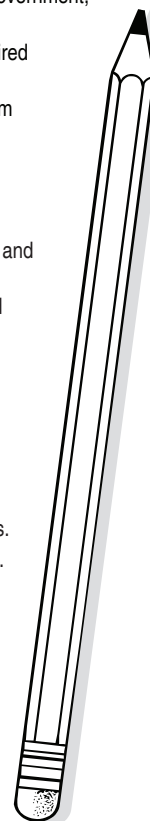

CLEP EXAMS: University of California does not grant credit for College Level Examination Program exams. CLEP credit CANNOT be used to certify IGETC. Some California State Universities will grant CLEP credit for certain areas and some will not grant credit at all. Transfer students are advised to contact the university they will be attending for specific information regarding CLEP credit.

Variable Topics Courses Numbered 22, 122, 23, 123, 98, 198

These courses are also called “Independent Studies”, “Special Studies”, “Special Topics”, “Internships”, etc. Credit for variable topics courses is given only after a review of the scope and content of the course by the receiving institution. This usually occurs after transfer and may require recommendations from faculty. Check with a counselor to prevent surprises.

Transfer Services

ASSIST: ASSIST is a computerized student-transfer information system that can be accessed over the World Wide Web. It displays reports of how course credits earned at one California college or university can be applied when transferred to another. ASSIST provides the most accurate and up-to-date information available about student transfer in California. Visit the website at www.assist.org.

CSU MENTOR: CSU Mentor is an online resource designed to help students and their families learn about the CSU system, select a CSU campus to attend, plan to finance higher education, and apply for admission. Personal data entered by the user is not released without the user’s expressed consent and direction.

CSU Mentor is free to use. The student will only pay the application fee charged directly by the CSU campus when an application for admission is submitted. Visit the website at www.csumentor.org.

UC PATHWAYS: PATHWAYS, the University of California’s online undergraduate admission information and application network.

- Information about financial aid and how to finance a UC education.
 - Answers for Transfers
 - UC campus Web sites, a list of links to the campuses for prospective students
 - Transfer/Application Center
 - Message Center - ask a question about undergraduate education or admission at UC
- Visit the website at <http://www.universityofcalifornia/admissions>

Transfer Agreements (TAA) A Transfer Admissions Agreement is a formal agreement between a student in attendance at Gavilan College and a receiving baccalaureate granting institution to which the student intends to transfer. The agreement guarantees admission to a transfer university a year in advance for the fall semester.

Because the requirements of universities vary, it is advisable that students consult a counselor for more detailed information and to develop an educational plan.

Gavilan College has Transfer Admission Agreements with several colleges and universities. Please check our website for specifics at www.gavilan.edu/counseling/TransferServices.html.

Articulation agreements are also available online at www.assist.org. For eligibility requirements visit the Counseling/Transfer Services webpage at www.gavilan.edu/counseling/TransferServices.html or call 408-848-4723 to schedule a counseling appointment.

Articulation Agreements Gavilan College has completed lower division course-to-course, major-to-major and general education agreements with all California State University (CSU), University of California (UC) and a number of private university campuses. These agreements ensure that participating universities will accept certain courses taken at Gavilan College to satisfy general education, major or elective university requirements.

The articulation officer, counselors and the Career/Transfer Resource Center staff have lists of participating insitutions. Articulation agreements are also available online. See information on www.assist.org.

Transfer Institute See page 18 of this schedule. Application on page 138.

Advanced Placement (AP) Gavilan College grants up to six semester units of transfer credit for each College Board Advanced Placement (AP) Test on which a student receives a score of 3 or better. The AP results must be submitted to the Office of Admissions & Records with a request for evaluation.

Students receiving a score of 3, 4 or 5 on the Math and English AP exams will be exempted from the placement assessment test. AP units will not apply toward financial aid, nor can they be used to satisfy the residency unit requirement.

Advanced Placement credit will be awarded as follows:

Examination	Score**	Equiv. Gav. College	Semester Units	IGETC Area
Art History	3,4,5	ART 1A, 1B	6	3A or 3B
Biology	3,4,5	BIO 10	4	5B w/lab
Chemistry	3,4	CHEM 30A	4	5A w/lab
	5	CHEM 1A	5	5A w/lab 3B and 6A
Chinese Language and Culture				
Computer Science A	3,4,5	CSIS 45	3	
Computer Science AB	3,4,5	CSIS 45,46	6	
Economics, Macro	3,4,5	ECON 1	3	4B
Economics, Micro	3,4,5	ECON 2	3	4B
English Language & Composition	3,4,5	ENGL 1A	3	1A
English Composition & Literature	5	ENGL 1A, 1B	6	1A or 3B*
(Max # Units in English= 6)				
Environmental Science				5A w/lab
European History*				3B or 4F*
French Language				3B and 6A
French Literature				3B and 6A
German Language				3B and 6A
Government & Politics:				
U.S.	3,4,5	POLS 1	3	4H
Comparative	3,4,5	POLS 3	3	4H
Human Geography				4E
Italian Language & Culture				3B and 6A
Japanese Language & Culture				3B and 6A
Latin Literature				3B and 6A
Latin: Vergil				3B and 6A
Math/Calc AB	3,4,5	MATH 1A	4	2A
Math/Calc BC	3,4,5	MATH 1B	4	2A
Math/Statistics	3,4,5	MATH 5	3	2A
Music Theory	3,4,5	MUS 3A	3	
Physics B	3,4,5	PHYS 2A	4	5A w/lab
Physics C Mechanics	3,4,5	PHYS 4A	4	5A w/lab
Physics C Electricity/Magnetism	3,4,5	PHYS 4B	4	5A w/lab
Psychology	3,4,5	PSYC 1A	3	4I
Spanish	3,4	SPAN 1B	5	
	5	SPAN 2A	5	3B and 6A
US History	3,4,5	HIST 1,2	6	3B or 4F*
World History				3B or 4F

* AP exams may be used in either area regardless of where the certifying CCC’s discipline is located. Example: US History at a CCC is approved for Area 3B. The US History AP may be used in either Area 3B or 4F.

** Scores of “3” may not be accepted for all courses by some 4 year colleges and universities.

Note: Educational plans for students preparing to transfer to any public or private institution can be developed.

Please see your counselor for additional information and to view copies of specific transfer agreements. The Counseling Office is located in SC108. For more information call 408-848-4723.

California Articulation Number System

The California Articulation Number (CAN) System provides a cross reference number for courses which have been evaluated by faculty and determined to be acceptable "in lieu of" each other. Only lower division, transferable, major preparation courses commonly taught on two- and four-year college and university campuses are included in the System.

The criteria for a campus to qualify to use a CAN Number includes written, faculty-approved articulation agreements on each course with a minimum of four public four-year California colleges and universities.

The CAN Number System is not a common numbering system. Each campus retains its own course numbers, prefixes and titles. The CAN (e.g., CAN ENGL 2) is listed parenthetically in catalog descriptions, class schedules and other publications as appropriate.

The CAN designation is assurance that the course or sequence of courses will be accepted in lieu of an identically designated CAN course or sequence at all participating campuses in California.

(CAN ENGL1A = CAN ENGL 1A at another college.)

Visit the Career/Transfer Resource Center

Services are designed to assist you throughout your time at Gavilan College.

- ◆ Information on career outlook, training and educational opportunities
- ◆ Career Assessment using EUREKA
- ◆ College Fair and Career Fair
- ◆ Transfer information
- ◆ Career and Transfer Workshops
- ◆ Articulation agreements using ASSIST
- ◆ College and university catalogs
- ◆ Assistance with admission procedures and referral to academic counseling
- ◆ Library of career reference materials
- ◆ Online Job Search/Research Portal

Located in SC102, on the main campus
For more information call 408-848-4818
or visit the website at www.gavilan.edu/transferctr

Intersegmental General Education Transfer Curriculum (IGETC)

The IGETC can be used by community college transfer students to fulfill lower division general education requirements for either the CSU or UC system without the need, after transfer, to take additional lower division general education courses, as long as your IGETC completion is certified at the community college. Obtain the Certification form from Admissions and Records.

Students are strongly encouraged to complete all IGETC requirements prior to transfer.

PARTIAL IGETC - If you are approaching readiness for transfer and are unable to complete one or two IGETC courses, you may be eligible to complete IGETC after transferring.

Warning: Students need Area 1 and 2 completed to meet minimum transfer admission requirements. Therefore, partial certification that acknowledges a deficiency in Area 1 and/or 2 may also indicate a student does not meet minimum transfer requirements.

If your petition for partial certification of IGETC is approved, you may be able to complete IGETC in one of the following ways:

- 1) Take an approved IGETC course, in the area(s) to be completed, at any California Community College, at a time that does not require concurrent enrollment, such as during the summer.
- 2) Take a course approved by the UC or CSU campus of attendance in the area(s) to be completed at a U.S. regionally accredited institution at a time that does not require concurrent enrollment, such as during summer school.
- 3) Take an approved IGETC course, in the area(s) to be completed, at any California Community College while concurrently enrolled at a UC or CSU campus. The student will be subject to the UC or CSU campus rules regarding concurrent enrollment, so this option may not be available.

- 4) Take a course approved by the UC or CSU campus of attendance at a United States regionally accredited institution in the area(s) to be completed while concurrently enrolled at a UC or CSU campus. The student will be subject to the UC or CSU campus rules regarding concurrent enrollment, so this option may not be available.
- 5) Take a comparable course at a UC or CSU campus in the area(s) to be completed. This option is at the discretion of each UC or CSU campus, so it may not be a choice available to the student.

You will be expected to complete IGETC before the beginning of the second full year of enrollment at your UC or CSU campus. Check with your campus advisor after you transfer for more information, including which options are available and which UC or CSU courses may be comparable to the IGETC courses remaining to be completed.

All UC and CSU campuses will accept IGETC with the exception of Fifth and Revelle Colleges at UC, San Diego. Since all majors are available at each of the five colleges at UC, San Diego, students will not be restricted in their choice of major if they use the IGETC.

A course cannot be used to satisfy more than one subject area of the IGETC (general education). However, major prerequisite courses can be used (double counted) to satisfy IGETC requirements.

CSU campuses' limitations on double counting of general education courses toward major preparations are not changed by IGETC.

Students who wish to be certified for both CSU and UC systems should take CMUN 1A, 5, 8 or 10 in Area 1 for CSU and meet the foreign language requirement for UC. Completing both provides flexibility and choices.

The courses for all IGETC areas must be completed with a grade of "C" or better before IGETC can be certified. A grade of "C-" is not acceptable.

UC/CSU Intersegmental General Education Transfer Curriculum IGETC - 2007-2008

Completion of all the requirements in the IGETC will permit a student to transfer from a community college to the California State University or the University of California without the need, after transfer, to take additional lower-division general education courses to satisfy campus general education requirements. All areas must be satisfied, and all courses must be completed with a grade of "C" or better before the IGETC can be certified. See requirements for partial IGETC certification in catalog. A student is strongly advised to complete a total of 60 transferable units before transferring. These will include the IGETC requirements, "major" prerequisites, and elective courses if needed.

(Students should request an IGETC certification from the Office of Admissions and Records before transferring.)

AREA 1	AREA 3	AREA 4
<p>ENGLISH COMMUNICATION CSU - 3 courses required, one each from Group A, B, and C UC - 2 courses required, one each from Group A and B</p> <p>1-A English Composition ENGL 1A Composition (3)</p> <p>1-B Critical Thinking / English Composition ENGL1C Critical Reasoning and Writing (3) PHIL 4 Critical Thinking and Writing (3)</p> <p>1-C Oral Communication (CSU requirement only) CMUN1A Introduction to Public Speaking (3) CMUN 5 Fund of Com Studies (3) CMUN 8 Interpersonal Communication (3) CMUN 10 Small Group Communication (3)</p>	<p>ARTS AND HUMANITIES At least 3 courses, with at least one course from the Arts and one course from the Humanities.</p> <p>3-A Arts ART 1A,B Art History (3) (3) ART 6 Art Appreciation (3) ART 21 Ancient Americas: A History Through Art (3) HIST 21 Ancient Americas: A History Through Art (3) HUM 6 Foreign Cinema (3) MUS 1A,B Music History and Literature (3) (3) MUS 6** Intro to World Music (3) THEA 1 Theater History (3) THEA 3 El Teatro Campesino (3) THEA 7 Theater Appreciation (3)</p> <p>3-B Humanities ENGL 1B Composition and Literature (3) ENGL 2A Introduction to Poetry (3) ENGL 2B Intro to Multi-Cultural Literature (3) ENGL 2C Introduction to Film and Fiction (3) ENGL 2E Introduction to Women Writers (3) ENGL 2F Childrens's Literature ** (3) ENGL 2H Mexican-American Literature (3) ENGL 2J Mythology (3) ENGL 4A British Literature - 449 through 1798 (3) ENGL 4B British Literature - 1798 to present (3) ENGL 5A Survey of American Literature - 1620 - 1865 (3) ENGL 5B Survey of American Literature - 1865 to present (3) * HIST 1 U.S. Hist through Reconstruction (3) * HIST 2 U.S. Hist Reconstrucion to Present (3) * HIST 3 History of California (3) * HIST 4A Hist of World Societies Before 1500 (3) * HIST 4B History of World Societies - 1500 to Present (3) * HIST 5 Women's Lives in Early U.S. Hist (3) * HIST 6 Women's Lives in Recent U.S. Hist (3) HIST 7A History of Western Civilization (3) HIST 7B History of Western Civilization (3) * HIST 10 African American History (3) * HIST 12 CultHist. of the Mexican American (3) * HIST 14 U.S. in the 20th Century: An Oral History Approach (3)</p>	<p>HUM 3 Introduction to the Cinema (3) HUM 4 Intro to the American Cinema (3) HUM 5 Humanities Through the Arts (3) HUM 10 Approaches to Contemporary Film (3) PHIL 1 Introduction to Philosophy (3) PHIL 3A Ethics (3) PHIL 3B Contemporary Moral Issues (3) PHIL 6 Comparative Religions (3) PHIL 7A History of Philosophy: Ancient to Medieval (3) PHIL 9 Philosophy of Religion (3) * SPAN 2A,B Intermediate Spanish (5) (5) SPAN 9A Spanish for Spanish Speakers ** (3)</p>
<p style="background-color: #e0e0e0;">AREA 2</p> <p>MATHEMATICAL CONCEPTS AND QUANTITATIVE REASONING 1 course, 3 semester, 4-5 quarter units</p> <p>2-A Math CSIS 26 Discrete Mathematics (4) + ECON 11 Statistics for Business & Economics (4) + GBUS 11 Statistics for Business & Economics (4) + MATH 1A Single Variable Calculus & Analytic Geometry (4) MATH 1B Single Variable Calculus & Analytic Geometry (4) MATH 1C Multivariable Calculus (4) MATH 2 Linear Algebra (3) MATH 2C Differential Equations (3) MATH 5 Introductions to Statistics (3) + MATH 6 Calc for Bus / Social Sci (3) MATH 7 Finite Mathematics (3) + MATH 8 Precalculus (5) + MATH 8A First Half of Precalculus (4) + MATH 8B Second Half of Precalculus (4) MATH 14 Math for the Liberal Arts (3)</p>		<p style="background-color: #e0e0e0;">AREA 4</p> <p>SOCIAL AND BEHAVIORAL SCIENCES Three courses from at least two disciplines or an interdisciplinary sequence. 9 semester, 12-15 quarter units.</p> <p>4-A Anthropology and Archeology ANTH 2 Introduction to Archeology (3) ANTH 3 Intro to Cultural Anthropology (3) ANTH 5 Magic, Witchcraft and Religion (3) ANTH 8 Intro to New World Archeology ** (3) ANTH 10 Native American Culture (3)</p> <p>4-B Economics + ECON 1 Principles of Macroeconomics (3) + ECON 2 Principles of Macroeconomics (3) + ECON 10 Fundamentals of Economics (3)</p> <p>4-E Geography GEOG 2 Cultural Geography (3)</p> <p>4-F History * HIST 1 U.S.Hist through Reconstruction (3) * HIST 2 United States History: Reconstruction to the Present (3) * HIST 3 History of California (3) * HIST 4A History of World Societies Before 1500 (3)</p>

<p>4-F History - Cont.</p> <p>* HIST 4B History of World Societies 1500 to Present (3)</p> <p>* HIST 5 Women's Lives in Early U.S. Hist. (3)</p> <p>* HIST 6 Women's Lives in Recent U.S. History (3)</p> <p>* HIST 10 African American History (3)</p> <p>* HIST 12 Cultural Hist of the Mexican American (3)</p> <p>* HIST 14 U.S. in the 20th Century: An Oral History Approach (3)</p> <p>4-G Interdisciplinary, Social & Behavioral Science</p> <p>CMUN 4 Intercultural Communication (3)</p> <p>SSCI 1 Introduction to Social Sciences (3)</p> <p>4-H Political Science, Government & Legal Institutions</p> <p>PHIL 12 Intro to Political Thought (3)</p> <p>POLS 1 Intro to American Government (3)</p> <p>POLS 3 Intro to Comparative Politics (3)</p> <p>POLS 4 Intro to International Relations (3)</p> <p>POLS 12 Introduction to Political Thought (3)</p> <p>4-I Psychology</p> <p>CD 2 Early Childhood Development (3)</p> <p>CD 3 Child Growth and Development During the School Years (3)</p> <p>PSYC 1A,B Introduction to Psychology (3)(3)</p> <p>PSYC 2 Early Childhood Development (3)</p> <p>PSYC 3 Child Growth and Development During the School Years (3)</p> <p>4-J Sociology & Criminology</p> <p>JOUR 10 Mass Media and Society (3)</p> <p>SOC 1A Introduction to Sociology (3)</p> <p>SOC 1B Intro to Sociology: Social Problems (3)</p> <p>SOC 3 Sociology of Race, Ethnicity and Cultural Identity (3)</p> <p>SOC 4 Sociology of Women and Men (3)</p> <p>SOC 10 Mass Media and Society (3))</p>	<p>+ CHEM 30A Elementary Chemistry (4)</p> <p>CHEM 30B Elementary Organic Biochemistry(4)</p> <p>GEOG 1 Physical Geography (3)</p> <p>GEOL 1 Introduction to Geology (4)</p> <p>GEOL 13 Environmental Geology ** (3)</p> <p>+ PHYS 1 Introduction to Physics (4)</p> <p>+ PHYS 2A General Physics (4)</p> <p>+ PHYS 2B General Physics (4)</p> <p>+ PHYS 4A Physics for Scientists and Engineers (Mechanics/Fluids/Waves) (4)</p> <p>+ PHYS 4B Physics for Scientists and Engineers (Electromagnetism) (4)</p> <p>+ PHYS 4C Physics for Scientists and Engineers (Thermodynamic/Optics/Moderns Physics) (4)</p> <p>+ PSCI 1 Principles of Physical Science (3)</p> <p>PSCI 2 Introduction to Meteorology (3)</p> <p>5B Biological Science</p> <p>AH 8 General Microbiology (5)</p> <p>+ AH 9 Human Physiology (5)</p> <p>+ AH 15 Survey of Human Anatomy and Physiology (5)</p> <p>ANTH 1 Intro to Physical Anthropology (3)</p> <p>BIO 1 General Biology (4)</p> <p>BIO 4 General Zoology (4)</p> <p>BIO 5 General Botany (4)</p> <p>+ BIO 7 Human Anatomy (4)</p> <p>BIO 8 General Microbiology (5)</p> <p>+ BIO 9 Human Physiology (5)</p> <p>+ BIO 10 Principles of Biology (4)</p> <p>BIO 13 Marine Biology (4)</p> <p>+ BIO 15 Survey of Human Anatomy and Physiology (5)</p> <p>ECOL 1 Conservation of Natural Resources(4)</p> <p>+ Transfer credit may be limited by either UC or CSU or both. Please consult with a counselor.</p>	<p>CSU Graduation Requirement in U.S. History, Constitution and American Ideals.</p> <p>Not Part of IGETC (May be completed prior to transfer.)</p> <p>For the baccalaureate degree, CSU requires one of the following combinations:</p> <p>HIST 1 & 2</p> <p>POLS 1 with either HIST 1 or 2</p> <p>CSU campuses have the discretion whether to allow courses used to satisfy the CSU US History, Constitution and American Ideals (AI) graduation requirement to count in both Area 3B or 4F and to meet the graduation requirement.</p>
<p>AREA 5</p>	<p>AREA 6</p>	<p>SUPPLEMENTARY NOTES</p>
<p>PHYSICAL AND BIOLOGICAL SCIENCES</p> <p>At least 2 courses, one Physical Science course and one Biological Science course; At least one must include a laboratory.</p> <p>Courses in BOLD include a laboratory component.</p> <p>7-9 semester, 9-12 quarter units</p> <p>5-A Physical Science</p> <p>ASTR 1 Intro to General Astronomy (3)</p> <p>CHEM 1A General Chemistry (5)</p> <p>CHEM 1B General Chemistry (5)</p> <p>CHEM 12A Organic Chemistry (5)</p> <p>CHEM 12B Organic Chemistry (5)</p>	<p>LANGUAGE OTHER THAN ENGLISH (UC REQUIREMENT ONLY)</p> <p>Proficiency equivalent to two years of high school study in the same language.</p> <p>6-A Language Other Than English</p> <p>FRNH 1B Elementary French (5)</p> <p>JPN 1B Elementary Japanese (5)</p> <p>* SPAN 1B Elementary Spanish (5)</p> <p>* SPAN 2A,B Intermediate Spanish (5)(5)</p> <p>* SPAN 12A Spanish for Spanish Speakers (5)</p> <p>* SPAN 12B Spanish for Spanish Speakers - Intermediate / Advanced (5)</p>	<p>1. A single course, even though listed in more than one place, can only be used to satisfy one subject area of the IGETC.</p> <p>2. IGETC is not advisable for high-unit majors, e.g. sciences, engineering.</p> <p>3. Eleanor Roosevelt and Revelle Colleges at UC San Diego do not accept the IGETC.</p> <p>4. IGETC may not be appropriate for students who have completed courses at a CSU or UC campus.</p> <p>5. "Double counting" of courses toward the major is not limited by the IGETC, but may be limited by other directives. The UC will also allow IGETC courses to count toward major requirements. CSU campus limitations on double counting of general education courses toward major preparation are not changed by the IGETC.</p> <p>+ Transfer credit may be limited by either UC or CSU or both. Please consult with a counselor.</p> <p>* Courses listed in multiple areas shall not be certified in more than one area except for courses in Languages Other Than English, which can be certified in both areas 3B and 6A.</p> <p>** Approved for fall 2008.</p>

The Gavilan Community College district assumes no liability for loss or damage of student personal property.

CSU General Education (Breadth) Requirements 2007-2008

certified by Gavilan College

Students transferring to the California State University system will qualify for admission as upper division transfers if they have completed (60) transferable units with a GPA of 2.0 ("C") or better (non-residents 2.4 or better). Within the (60) unit requirement, the (9) units in Area A, Area B-4 (Mathematics), and (18) additional semester units of general education coursework must be completed with a grade of 2.0 or better in each course. Students who complete the following pattern will have satisfied the lower division General Education requirements for the California State University BA / BS degree. A minimum of (9) semester units of General Ed coursework must be completed at the upper division level after transfer; some CSU campuses require more than (9) units. (See a counselor for further information.)
(Students should request a general education certification from the office of Admissions and Records before transferring.)

AREA A			
<p>COMMUNICATION IN THE ENGLISH LANGUAGE AND CRITICAL THINKING Select one course from each category. All courses must be completed with a grade of "C" or better. 9 semester units or 12-15 quarter units</p> <p>A - 1 ORAL COMMUNICATION CMUN 1A Introduction to Public Speaking (3) CMUN 5 Fundamentals of Comm Studies (3) CMUN 8 Interpersonal Communication (3) CMUN 10 Small Group Communication (3)</p> <p>A - 2 WRITTEN COMMUNICATION ENGL 1A Composition (3)</p> <p>A - 3 CRITICAL THINKING ENGL 1C Critical Reasoning and Writing (3) PHIL 2 Logic (3) PHIL 4 Critical Thinking and Writing (3)</p>	<p>B - 2 LIFE SCIENCE ANTH 1 Intro to Physical Anthropology (3) BIO 1 General Biology (4) BIO 4 General Zoology (4) BIO 5 General Botany (4) BIO 7 Human Anatomy (4) BIO 8 General Microbiology (5) BIO 9 Human Physiology (5) BIO 10 Principles of Biology (4) BIO 13 Marine Biology (4) BIO 15 Survey of Human Anatomy and Physiology (5) ECOL 1 Conservation of Natural Resources(4)</p> <p>B - 3 LABORATORY ACTIVITY See Areas B - 1 & B - 2 above</p> <p>B - 4 Mathematics/Quantitative Reasoning Grade "C" or better is required CSIS 26 Discrete Math (4) ECON 11 Statistics for Bus and Econ (4) GBUS 11 Statistics for Bus and Econ (4) MATH 1A, B Single-Variable Calculus and Analytic Geometry (4) (4) MATH 1C Multivariable Calculus (4) MATH 2 Linear Algebra (3) MATH 2C Differential Equations (3) MATH 5 Introductions to Statistics (3) MATH 6 Calculus for Bus / Social Science (3) MATH 7 Finite Mathematics (3) MATH 8 Precalculus (5) MATH 8A First Half of Precalculus (4) MATH 8B Second Half of Precalculus (4) MATH 12 Math for Elementary Teachers (3) MATH 14 Math for the Liberal Arts (3)</p>	<p>ART 6 Art Appreciation (3) ART 8A Beginning Photography From Analog to Digital (3) ART 10A Cultural History of Ceramics (3) ART 13 Three Dimensional Design (3) ART 14 Beginning Mural Painting (3) ART 21 Ancient Americas: A History Through Art (3) ART 25A Art Methods (3) CD 25A Art Methods (3) CMUN 2 Oral Reading (3) HIST 21 Ancient Americas: A History Through Art (3) HUM 6 Foreign Cinema (3) HUM 10 Approaches to Contemporary Film (3) MUS 1A, B Music, History, and Literature (3) (3) MUS 3A Harmony-Theory-Musicianship (4) MUS 4A Beginning Piano (3) MUS 6 * Intro to World Music (3) THEA 1 Theater History (3) THEA 3 El Teatro Campesino (3) THEA 4 Oral Reading (3) THEA 7 Theater Appreciation (3) THEA 12A Acting: History and Practice (3) THEA 20 Introduction to Script Writing (3)</p>	
AREA B			
<p>PHYSICAL UNIVERSE AND ITS LIFE FORMS One course from each category. The Physical or Life Science course must include a laboratory (indicated in BOLD). 9 semester units or 12-15 quarter units</p> <p>B - 1 PHYSICAL SCIENCE ASTR 1 Intro to General Astronomy (3) CHEM 1A,B General Chemistry (5) (5) CHEM 12A,B Organic Chemistry (5) (5) CHEM 30A Elementary Chemistry (4) CHEM 30B Elementary Organic Biochemistry (4) GEOG 1 Physical Geography (3) GEOL 1 Introduction to Geology (4) GEOL 13 Environmental Geology (3) PHYS 1 Introduction to Physics (4) PHYS 2A, B General Physics (4)(4) PHYS 4A Physics for Scientists & Engineers (Mechanics / Fluids / Waves) (4) PHYS 4B Physics for Scientists and Engineers (Electromagnetism) (4) PHYS 4C Physics for Scientists & Engineers (Thermodynamic / Optics Moderns Physics) (4) PSCI 1 Principles of Physical Science (3) PSCI 2 Introduction to Meteorology (3)</p>	<p style="text-align: center;">AREA C</p> <p>ARTS, LITERATURE, PHILOSOPHY & FOREIGN LANGUAGE Required: English 1B, one course from C-1 and one course from C-2 9 semester units or 12-15 quarter units</p> <p>C - 1 Arts (Art, Dance Music, Theater) Minimum of 2 units from one of these courses. ART 1A, B Art History (3) (3) ART 2A Two Dimensional Design (3) ART 3A Drawing and Composition (3)</p>	<p>C - 2 Humanities (Literature, Philosophy,Foreign Language) ART 11 Creativity, Imagination, & Innovation(3) ART 21 Ancient Americas: A History Through Art (3) HIST 21 Ancient Americas: A History Through Art (3) ENGL 2A Introduction to Poetry (3) ENGL 2B Introd to Multi-Cultural Literature (3) ENGL 2C Intro to Film and Fiction (3) ENGL 2E Introduction to Women Writers (3) ENGL 2F Children's Literature* (3) ENGL 2H Mexican-American Literature (3) ENGL 2J Mythology (3) ENGL 4A British Literature - 449 through 1798 (3) ENGL 4B British Literature - 1798 to present (3) ENGL 5A Survey of American Literature - 1620 - 1865 (3) ENGL 5B Survey of American Literature - 1865 to present (3) ENGL 9A Introduction to Creative Writing (3) ENGL 9B Advanced Creative Writing (3) ENGL 9C Poetry Writing (3) FRNH 1A, B Elementary French (5) (5)</p>	

<p>C - 2 Humanities (continued)</p> <p>HIST 1 U.S. Hist through Reconstruction (3) HIST 2 United States History - Reconstruction to the Present (3) HIST 3 History of California (3) HIST 4A History of World Societies Before 1500 (3) HIST 4B History of World Societies Before 1500 (3) HIST 5 Women's Lives in Early U.S. History (3) HIST 6 Women's Lives in Recent U.S. History (3) HIST 7A, B History of Western Civilization (3)(3) HIST 10 African American History (3) HIST 12 Cult Hist of the Mexican American U.S. in the 20th Century: An Oral History Approach (3) HUM 3 Introduction to the Cinema (3) HUM 4 Intro to the American Cinema (3) HUM 5 Humanities Through the Arts (3) HUM 10 Approaches to Contemporary Film (3) JPN 1A, B ± Elementary Japanese (5)(5) JOUR 10 Mass Media and Society (3) PHIL 1 Introduction to Philosophy (3) PHIL 3A Ethics (3) PHIL 3B Contemporary Moral Issues (3) PHIL 6 Comparative Religions (3) PHIL 7A Hist of Philosophy: Ancient to Medieval (3) PHIL 9 Philosophy of Religion (3) SOC 10 Mass Media and Society (3) SPAN 1A, B Elementary Spanish (5)(5) SPAN 2A, B Intermediate Spanish (5)(5) SPAN 9A Spanish for Spanish Speakers (3) SPAN 12A Spanish for Spanish Speakers (5) SPAN 12B Spanish for Spanish Speakers Intermediate/Advanced (5)</p>	<p>NOTE: For the baccalaureate degree, one of the following combinations will satisfy the CSU graduation requirement in US History, Constitution and American Ideals:</p> <p>HIST 1 & 2, POLS 1 with either HIST 1 or 2.</p> <p>Requirement 2:</p> <p>D - 1 Anthropology and Archeology ANTH 2 Introduction to Archeology (3) ANTH 3 Intro to Cultural Anthropology (3) ANTH 5 Magic, Witchcraft and Religion (3) ANTH 8 Intro to New World Archeology (3) ANTH 10 Native American Culture (3)</p> <p>D - 2 Economics ECON 1 Principles of Macroeconomics (3) ECON 2 Principles of Microeconomics (3) ECON 10 Fundamentals of Economics (3)</p> <p>D - 3 Ethnic Studies CMUN 4 Intercultural Communication (3) HIST 10 African American History (3) HIST 12 Cultural History of the Mexican American (3) SOC 3 Sociology of Race, Ethnicity & Cultural Identity (3)</p> <p>D - 4 Gender Studies HIST 5 Women's Lives in Early U.S. Hist. (3) HIST 6 Women's Lives in Recent U.S. Hist. (3) SOC 4 Sociology of Women and Men (3)</p> <p>D - 5 Geography GEOG 2 Cultural Geography (3)</p> <p>D - 6 History HIST 1 U.S. Hist through Reconstruction (3) HIST 2 United States History - Reconstruction to the Present (3) HIST 3 History of California (3) HIST 4A History of World Societies Before 1500 (3) HIST 4B History of World Societies Before 1500 to Present (3) HIST 5 Women's Lives in Early U.S. Hist. (3) HIST 6 Women's Lives in Recent U.S. Hist. (3) HIST 10 African American History (3) HIST 12 Cultural History of the Mexican American (3) HIST 14 U.S. in the 20th Century An Oral History Approach (3)</p> <p>D - 7 Interdisciplinary Social & Behavioral Sci. ANTH 9 Cultural Context of Childhood (3) CMUN 4 Intercultural Communication (3) PSYC 6 Conflict Resolution (3)</p>	<p>AJ 6 Intro to Conflict Resolution (3) POLS 6 Intro to Conflict Resolution (3) PSYC 7 Cultural Context of Childhood (3) CD 7 Cultural Context of Childhood (3) SSCI 1 Introduction to Social Sciences (3)</p> <p>D - 8 Political Science, Government and Legal Institutions POLS 1 Intro to American Government (3) POLS 3 Intro to Comparative Politics (3) POLS 4 Intro to International Relations (3) POLS 12 Introduction to Political Thought (3) PHIL 12 Introduction to Political Thought (3)</p> <p>D - 9 Psychology PSYC 1A, B Intro to Psychology (3) (3) PSYC 2 Early Childhood Development (3) PSYC 3 Child Growth and Development During the School Years (3) CD 2 Early Childhood Development (3) CD 3 Child Growth and Development During the School Years (3)</p> <p>D - 0 Sociology and Criminology SOC 1A Introduction to Sociology (3) SOC 1B Introduction to Sociology: Social Problems (3) SOC 3 Sociology of Race, Ethnicity and Cultural Identity (3) SOC 4 Sociology of Women and Men (3) SOC 10 Mass Media and Society (3) JOUR 10 Mass Media and Society (3)</p>
AREA E		
<p>LIFE-LONG UNDERSTANDING AND SELF-DEVELOPMENT</p> <p>1. One unit of Physical Education activity course</p> <p>2. Two units from:</p> <p>AH 3 The Person in the Life Cycle (3) AH 11 Nutrition (3) BIO 11 Nutrition (3) GUID 6 Life Skills for Higher Education (2) HE 1 Health Education (3) HE 2 Human Sexuality (3) PSYC 5 Self-Assessment and Career Development (2) GUID 1 Self-Assessment and Career Development (2) □ PSYC 2 Early Childhood Development (3) □ PSYC 3 Child Growth and Development During the School Years (3) » CD 2 Early Childhood Development (3) » CD 3 Child Growth and Development During the School Years (3) PSYC 41 Psychology of Adjustment (2) SOC 21 Marriage and the Family (3)</p>		
<p>AREA D</p> <p>SOCIAL, POLITICAL AND ECONOMIC INSTITUTIONS</p> <p>Two requirements: select one course from Requirement 1 and select 2 courses from Requirement 2.</p> <p>9 semester units or 12-15 quarter units</p> <p>Requirement 1:</p> <p>HIST 1 U.S. Hist through Reconstruction (3) HIST 2 U.S. Hist Reconstruction to the Present (3) POLS 1 Intro to American Government (3)</p>	<p>Courses listed under more than one discipline or area may be used only once to satisfy an area.</p> <p>* = Approved for Fall 2008 ± = Approved retroactively for Fall 2005.</p> <p>NOTE: "x" or "»". PSYC 2 + 3 acceptable for AREA E only if taken as combination.</p> <p>NOTE: Transfer credit of certain courses (especially Science and Math) may be limited by UC or CSU or both. Consult with a counselor.</p>	

General Information

Attendance Students who fail to attend the first class session may be dropped by the instructor in order to admit waiting students. Generally, students missing one more class hour than the unit value for that course, without making prior arrangements, may be dropped without the possibility of credit. However, a student should not assume that he or she will be dropped by the instructor; it is the responsibility of the student to make sure that courses are officially dropped.

Advisories Course advisory is recommended preparation for a course. It is not a prerequisite to taking a course but is strongly suggested that the advisory be met prior to enrollment as success in the course may depend upon having that skill or knowledge level. For example, a course advisory that reads "to be eligible for English 250 and English 260 in order to enroll in Psychology 1A" strongly recommends that you have successfully completed (with a "C" grade or better or a "credit") the previous courses, English 440 and English 260. This becomes critical in being able to read and understand college textbooks.

Campus Safety and Crime Statistics Contact the Gavilan College Security Dept. at 408-710-7490 (or dial "10" from any campus extension) to report criminal or potential criminal activity.

Campus safety information and crime statistics are available online at www.gavilan.edu/safety. If you would like a hard copy of this information, copies are available at Admissions and Records (SC111) and the Campus Security office (S/M bldg.) or call 408-848-4703 to have a copy mailed to you.

Course Repetition There are limitations on the number of times a student may repeat a course. All courses listed in this publication with no repeat notation following the description may be repeated once without filing a petition if a grade of D, F, NC or NP was earned. A student may file a petition to repeat a course a second time if a grade of D, F, NC or NP is earned again. To file a petition, the student must meet with a counselor to evaluate circumstances and receive written approval. The student's transcript and grade point average will reflect the last grade the student receives in the course. A student may petition to repeat the course a third time by filing a Request to Repeat a Course Under Special Circumstances and providing the necessary documentation to support the special circumstances claim.

To repeat a course in which the student has received a final grade of "C" or better, a student must file a Request to Repeat a Course Under Special Circumstances prior to registering for the course again. Units and grade points for the repeated course are not computed in the grade point average unless the course is being repeated to meet legally mandated training requirements as a condition of continued paid or volunteer employment. This request must be approved by a counselor.

Pass/No Pass, Letter Grade Option For some courses, students have the option of selecting a final grade of Pass/No Pass or a traditional letter grade of "A", "B", "C", etc. Review the course description in this schedule to determine which courses are designated as having this grading option.

Before selecting a grading option, students should consider the following:

- Once the option has been selected, the student's decision is final and irreversible.
- To select one option over another, a student must complete the Grading Option form and file it with the Admissions & Records Office or indicate a preference when registering online prior to the NRS (No Record Shown) date for the course. This date is either the end of the fourth week (for a semester-long course) or 30% of the course meetings (for a short-term course.)
- If the student opts for a P/NP final grade, the units are not included in the semester GPA but are considered for the purposes of academic and progress probation and dismissal.
- A P/NP grade is not used in consideration of honors.
- A total of 20 units of P/NP graded units (not including those courses required by

the major which are designated P/NP only) may be applied to an Associates's Degree or Certificate.

- The student should carefully consider the transferability of P/NP units to other institutions. Some universities may not accept any pass/no pass courses and others limit the amount of pass/no pass units that will be accepted. Please consult your counselor before selecting the pass/no pass option.

Prerequisites and Co-requisites A prerequisite is a course or skill level that is required before you can enroll in another course. For example, English 250 is a prerequisite for English 1A. Courses used to meet prerequisite requirements must have been completed with a "C" grade or better or "Pass".

A co-requisite is a set of courses that you must take at the same time.

If you believe that you have the equivalent of the prerequisite through another means (courses at another college, AP tests, work experience, etc.) speak with your counselor.

CHALLENGING A PREREQUISITE

Students who believe that they have already fulfilled a prerequisite, or that a prerequisite has been improperly established or implemented, may challenge the prerequisite. The student is responsible for providing compelling evidence to substantiate the challenge based on one of the following:

- The prerequisite course has not been made reasonably available.
- The prerequisite was established in violation of regulation or in violation of the District-approved processes.
- The prerequisite is in violation of this Article.
- The prerequisite is discriminatory or is applied in a discriminatory manner.
- The student has the knowledge or ability to succeed in the course despite not meeting the prerequisite.

Challenge forms are available in the Admissions & Records Office or from a counselor and must be completed and returned to the Vice President of Instruction prior to the first day of classes.

Transcripts Transcripts of a student's permanent academic record are released ONLY with written authorization of the student. Telephone requests will not be accepted. The first two copies are free; there is a \$4 charge for each copy thereafter. Transcripts are normally sent out within five days of the request. This response time may be longer during busy periods such as the first two weeks of a new semester. Urgent requests cannot be honored during the late registration period but can normally be produced within an hour at a cost of \$7 per copy.

Unofficial transcripts are available to students on the Gavilan College homepage. Click on the Self-Serve Banner icon.

Withdrawal Students may withdraw from a course by notifying Admissions & Records either online or in person. The following grading practices apply when withdrawing from a course:

- A student who withdraws from a course prior to 30% of the class meetings will receive no grade of record.
- A student may withdraw from a course and receive a grade of "W" prior to completion of 75% of the class meetings for the course; thereafter, the student will receive whatever grade they would have earned, based upon the entire semester's work.
- A student may withdraw from a course up to four times and receive a grade of "W"; after a fourth "W", the student will receive the grade they would have earned, based upon the entire semester's work.
- A withdrawal may be excluded from the four-time maximum limit in the case of extenuating circumstances such as natural disasters or other circumstances beyond the control of the student including verified cases of accident or illness.

Policies and Procedures

College policies and procedures are available by accessing the Gavilan College website at www.gavilan.edu or by visiting the office of the Vice President of Student Services (SC130).

Academic Freedom It shall be the policy of the College to maintain and encourage full freedom for its faculty to teach, research and pursue knowledge subject to the applicable provisions of law.

In the exercise of this freedom the faculty member may, as provided in the U.S. and California Constitutions and other applicable laws, discuss his/her own subject or area of competence in the classroom, as well as any other relevant matters, including controversial matters, so long as he/she distinguishes between personal opinions and factual information.

Faculty shall be free from unlawful harassment or from unlawful interference or restrictions based on political views.

Faculty shall be free from any and all forms of electronic or other listening or recording devices, except with his/her express and non-continuing consent, except where allowed otherwise by law.

The Board shall not unlawfully inquire into, nor predicate any adverse action upon a faculty member's personal, political or organizational activities or preferences.

The Board shall not interfere with a faculty member's freedom of speech or use of materials in any teaching assignment, except as allowed by law.

The intent is to allow those activities protected by constitutional freedom of speech and other forms of academic freedom protected by the laws of the State of California and the laws of the United States.

Disabilities

AMERICAN'S WITH DISABILITIES ACT (ADA) COMPLIANCE: If you have a verified disability and need academic materials in an alternate format or other services, contact the Disability Resource Center at 408-848-4865 or the Vice President of Student Services at 408-848-4738 for assistance.

RESOURCES FOR STUDENTS WITH DISABILITIES: Students requiring academic or physical accommodations because of visual, physical, learning and/or other verified disabilities should contact the Disability Resource Center at 408-848-4865.

Discrimination

PROHIBITION OF HARASSMENT AND HATE CRIMES (Reference: Education Code sections 212.5; 66252; 66281.5): The District is committed to providing an academic and work environment that respects the dignity of individuals and groups. The District shall be free of sexual harassment and all forms of sexual intimidation and exploitation. It shall also be free of other unlawful harassment and hate crimes, including those which are based on any of the following statuses; race, color, religion, ancestry, national origin, disability, sex (i.e., gender), sexual orientation, or the perception that a person has one or more of the foregoing characteristics.

NON-DISCRIMINATION: The district is committed to equal opportunity in educational programs, employment, and all access to institutional programs and activities.

Drug Free Schools and Campuses Act District Policy AP 3550 prohibits "the use, distribution, sale or possession of alcohol, narcotics, dangerous or illegal drugs or other controlled substances, as defined in California statutes, on District property or at any function sponsored by the District." Gavilan College complies with the Drug-Free Schools and Campuses Act of 1989 and the Drug-Free Workplace Act of 1988.

The college recognizes the legal drinking age of 21 years and enforces all state laws regulating the use of alcoholic beverages. All members of the campus community are subject to disciplinary action and/or criminal prosecution for the on-campus

possession, use, sale or distribution (by either sale or gift) of any quantity of inappropriate prescription drugs, or controlled substances as defined by the State of California Health and Safety Code. Students found to be in violation of this policy may be subject to the Standards of Student Conduct and Discipline Procedures. If warranted, employees will also be subject to disciplinary sanction.

For Free Confidential Assistance:

On-Campus:

- Counseling Center, 408-848-4723
- Student Health Services, 408-848-4791

Off-Campus:

- Alcoholics Anonymous, 408-374-8511; www.AASanJose.org
- Narcotics Anonymous, 408-998-4200
- National Council on Alcoholism & Drug Dependence 408-292-7292

Further detailed information on the risks associated with the use of alcohol and other drugs may be obtained from the Gavilan College website: www.gavilan.edu. Click on Drug Free Schools and Campus Act of 1989 and the Drug Free Workplace Act of 1988.

Health Consequences:

- Impaired learning due to poor concentration, fatigue, drowsiness, anxiety, altered perception, confusion, indifference, depersonalization, memory loss, panic attacks and drug-induced psychosis.
- Impaired judgment leading to driving under the influence of alcohol/other drugs, accidents, violent and abusive behavior, criminal acts, financial troubles, unwanted pregnancy, sexually transmitted diseases, acquaintance rape, attempted or accomplished suicide, permanent injury or death as a result of substance overdose.
- The use of intravenous drugs can result in hepatitis, tetanus, abscesses, and AIDS.
- The use of stimulants can lead to cardiac fibrillation, heart attack, seizures, respiratory arrest and death.
- The most common negative health consequences from occasional drinking are trauma incidents such as auto accidents and violent behavior which involve both the drinker and non-drinking victims.
- Long-term alcohol abuse can cause brain damage, cirrhosis of the liver, hepatitis, permanent coordination loss, ulcer disease, gastritis, pancreatitis, heart disease, stroke, anemia, sexual dysfunction, cancers and many other health problems.

Legal Sanctions:

As a student, if you are under the influence of alcohol and/or other drugs, or if you are discovered selling or dispensing drugs on campus or at any college function, you can be suspended, expelled and criminally prosecuted.

If you are an employee at Gavilan College, you may be placed on probation, terminated and criminally prosecuted for the use, sale or possession of illegal drugs and/or alcohol on campus, or at college sponsored events.

For a first offense of driving under the influence of alcohol and/or drugs, you may serve 96 hours to six months in jail and pay a fine. It is unlawful for anyone with a blood alcohol content (BAC) level of .08 percent or above to drive a motor vehicle or ride a bicycle on a highway. For pot or marijuana (1 oz. or less), you can be fined up to \$100 and receive a criminal citation.

- For possession of marijuana (more than 1 oz.) you may receive up to 6 months in county jail, up to a \$500 fine, or both.
- For possession of cocaine you can be imprisoned in a state prison.
- For sales of any illegal drug you can be imprisoned in a state prison.

- Any person under the age of 21 years who has any alcoholic beverage in his or her possession on any street or highway or in any public place can be convicted of a misdemeanor.
- It is a misdemeanor crime to sell, give or furnish alcohol to anyone under 21 years of age.
- Carriers of motor vehicle insurance can increase premiums, cancel or deny renewal as a result of driving-under-the-influence convictions.

Family Educational Rights and Privacy In compliance with the Federal Family Education Rights and Privacy Act of 1974 (also known as the Buckley Amendment) and California Title V regulations (SB 182), Gavilan has adopted the following policy:

- Official academic, discipline and other necessary records are maintained on all students who have applied to attend Gavilan College.
- These records are maintained by and in the Admissions & Records Office and the Office of the Vice President of Student Services.
- These records will be released only upon the written authorization of the student upon payment of any or all fees and charges due the college, except as provided by law. Unless otherwise directed, the following directory of information may be released by Gavilan without written consent of the student:
 - name of the student
 - dates of attendance at Gavilan
 - date of graduation and degree or certificate awarded

Students who do not wish to have the above information released as directory information may notify the Admissions & Records Office in writing within the first week of each term. Copies of the complete federal and state regulations are available in the Vice President of Student Services Office and may be reviewed by students by appointment.

Open Enrollment Unless specifically exempted by statute, every course, course section or class, the average daily attendance of which is to be reported for state aid shall be fully open to enrollment and participation by any person who has been admitted to the college and who meets all prerequisites. Class enrollment is limited by size of facility and program content. Gavilan College is in compliance with Section 504 of the Rehabilitation Act of 1973 and the Americans with Disabilities Act of 1990.

Parking on Campus Semester permits are available during all registration periods. All vehicles parked on the main campus are required to display a parking permit. Day permits are available from coin-operated machines located in parking lots A, E, H and at the south entrance to campus. Student parking is permitted in Lots A, C, E or H except where restricted to staff, guests, or the disabled. Parking Lot D is reserved for staff and disabled only. Guest parking permits are issued at the Facilities Use Scheduling Department (PB11A). Disability parking is available in all lots to those displaying a placard from the California Department of Motor Vehicles.

Parking is enforced by the campus security department and local law enforcement. Student and staff spaces are enforced Mon - Thurs: 7am-10 p.m and Fri: 7 am- 5 pm. All other spaces and areas are enforced at all times. A complete list of parking regulations is available at the main switchboard/reception area and outside the security office (OE133).

Sexual Assault Sexual assault is a crime regardless of when or where it occurs, or what the relationship is between the attacker and the victim. Gavilan College is committed to providing a safe environment for students and staff. Reports of sexual misconduct will be thoroughly investigated and the victim informed of the outcome. If you, or someone you know, have been the victim of sexual assault, notify Campus Security at 408-710-7490. Confidential counseling is available on campus through Counseling (848-4723) or Student Health Services 408-848-4791.

Off campus confidential counseling is available at Community Solutions: 408-683-4118; 24-hour crisis line: 1-877-363-7238.

Smoke-Free Buildings (BP 6500) Smoking is prohibited inside all public buildings, within twenty 20 feet of all entrances/exits, operable windows or ventilation air intake. Smoking is also prohibited in all college-owned vehicles. Tobacco products shall not be sold on campus either through vending machines or campus establishments. Implementation of the campus smoke-free environment policy will be the responsibility of every student, faculty member, staff person and visitor on campus.

Students' Problem Resolution Process Procedures have been adopted to allow for student grievances against Gavilan staff members. The formal policy is available through the Vice President of Student Services Office, in the college catalog and on the Gavilan College website, www.gavilan.edu. Students are encouraged to resolve issues informally by talking with college staff members.

Title VI, Title IX, and ADA/Section 504/508 To file complaints in the following areas please contact the Equal Opportunity Officer, Joseph D. Keeler, Vice President of Administrative Services, HR101 (408-848-4731). or Shairon Zingsheim, Director of Human Resources, HR103 (408-848-4753).

The areas are:

- Civil rights complaints (Title VI)
- Gender equity, sex discrimination/harassment complaints (Title IX)
- Persons with disabilities discrimination complaints (ADA/Section 504/508)

Vocational English Skills Limited English language skills will not be a barrier to admission to and participation in vocational education programs.

Gavilan's Grade Policy

Grade	Grade Points	Definition
A	4	Excellent
A-	3.7	Excellent
B+	3.3	Good
B	3	Good
B-	2.7	Good
C+	2.3	Satisfactory
C	2	Satisfactory
D	1	Passing, Less Than Satisfactory
F	0	Failing
P*	0	Pass - at least satisfactory, units awarded not counted in grade point average or in consideration of honors.
NP*	0	No Pass - less than satisfactory or failing, units not counted in grade point average.
I	0	Incomplete - incomplete academic work for unforeseeable, emergency and justifiable reasons after the last day to withdraw with a "w". Request for this grade must be initiated by the student. Work to be completed must not involve further class attendance or instruction. The Incomplete must be made up during the next term of attendance, summer excluded, within the next year.
W	0	Withdrew - withdrew from class after the NRS (No Record Shown) period and before the W deadline. Students withdrawing from courses after the W deadline must be awarded a letter grade or, if appropriate, request an incomplete (see above.)
MW	0	Military Withdrawal

* To be used ONLY if final grade for a course is designated Pass/No Pass

Student Life

Associated Student Body (ASB) The ASB is the official student organization on campus and provides the majority of student input and recommendations on critical campus issues to faculty, staff, administration and the Board of Trustees.

The Student Senate is a representative body of students who meet weekly to plan, implement and evaluate college activities and services that meet the needs of Gavilan College students. Any student who meets the requirements of the ASB's by-laws may become a voting member of the Student Senate. The elected and appointed officers provide a liaison between the students and academic departments and student services. The variety of leadership positions allows for different levels of involvement so that students can balance their academic and extracurricular loads effectively.

The political and practical leadership skills that students develop through the ASB are supplemented through a leadership course offered through the Political Science and Psychology Departments (POLS 27; PSYC 27). The curriculum includes practical skills that are applicable to college-related opportunities and other professional and personal environments. The curriculum is an interdisciplinary approach to contemporary leadership. This is an elective course that is transferrable to the CSU system and meets a GE requirement for the Gavilan College A.A./A.S. degree. Although the UC system does not accept the units for the class, it gives added consideration to those students who have been involved in student government and other college governance activities. Employers also look favorably upon a student's involvement in college leadership.

ASB CARDS: The benefits of buying a student body card are many. Revenue supports social and cultural activities on campus and provides the purchaser with discounts at athletic and cultural events and free bluebooks and scantrons (testing supplies) in the bookstore. Many businesses in Gilroy, Morgan Hill and Hollister offer discounts to card holders. Visit the ASB office in the Student Center - room 158 or call 408-848-4777.

Publications **The Gavilan Press**, an independent student newspaper, has provided students with a real world journalism experience and a public forum for their ideas and opinions since 1967. The newspaper covers events, issues and people that shape, reflect and define the college and the world. The Gavilan Press is also available online. Go to www.gavilanpress.com. Call 408-848-4837 for more information.

The **Gavilan College Literary Journal** provides a forum for creative writers, helping to model and sustain the practice of writing poetry and prose. For more information call the Writing Center at 408-848-4811 or Scott Sandler at 408-846-4979.

Rho Alpha Mu - Honor Society Rho Alpha Mu is the Gavilan College chapter of Alpha Gamma Sigma, the California Community College Honor Scholarship Society. Its purpose is to recognize student scholarship, contribute to the social and cultural life of the campus and to provide and promote active involvement with the larger community through voluntary community service activities. Membership is open to all those with at least a 3.0 grade point average. There are a number of financial award possibilities for members in good standing. For more information call 408-846-4947.

Theatre Productions

The Gavilan College Theatre offers a range of plays, including childrens' plays, musicals and Shakespearean productions. In addition to performing on stage, students learn backstage and technical production skills. For more information visit www.gavilan.edu/theatre.

TADA Productions - The Gavilan ASB Theatre Club sponsors several social and cultural events during the school year including: *Fiesta Mexicana*, a Folklorico Concert; *Historias de mi Madre* a Community Solutions event for Domestic Violence Awareness month; *One Night Stand(s)*, fall & spring stand-up workshops and Comedy Night(s); and other student generated performances.

In 1985, the Gavilan College **Summer Theatre Arts Repertory (STAR)** Program was created to give Gavilan College Theatre Arts students an opportunity to share their passion for the performing arts with South County youth. Students from the academic program serve as STAR leaders, often directing and producing plays. The Theatre Arts Program provides academic credit, production experience, and the opportunity for individual growth through the arts. For more information, call 408-848-4764 or visit www.gavilan.edu.star.



Ambassadors
Aneme
Chi Sigma Lota
(Administration of Justice)
Cheerleading
CDC Parenting Club
Christian Fellowship
COSMO
Digital Media
EOPS
Gavilan Music
Health Promotion
GavTV
Inception Literary Club
International Club
Latina Leadership Network
MANO (Men's Academic Network Organization)
MESA (Math Engineering Science Achievement)
OUT
Parent's Club
Rho Alpha Mu
Science Alliance
TADA/Theatre Arts
Teachers For Tomorrow
The Gavilan Press/Student Newspaper



A variety of clubs and organizations have been established to provide opportunities for students to participate in scholastic, social, political, cultural and recreational pursuits. Club activities are coordinated and supported through the Student Senate. Students are encouraged to start clubs if they have a particular interest not represented currently on campus.

ASB CLUBS

For more information call
408-848-4777.

Completed Projects through 12/31/08

- Tennis Court repairs
- Renovation of Physical Science, Chemistry, Life Science buildings
- Renovation of Occupational Education Building Phase 1
- Boiler replacement
- ADA transition planning
- Infrastructure replacement
- Parking Lot improvements Phases 1 and 2
- Lighting improvements Phases 1 and 2
- Computer Replacement
- Enterprise Resource System implementation
- Coyote Valley land acquisition
- San Benito County land acquisition

About Measure E

On March 2, 2004, district voters approved Measure E, a \$108 million facilities improvement bond measure that will upgrade and expand the facilities for higher education in the Gavilan Joint Community College District. Upgrades will be made to outdated plumbing and wiring, renovate aging classrooms and libraries, provide access for disabled students, improve campus safety, and plan for the future by acquiring land for permanent facilities in San Benito County and the greater Morgan Hill / Coyote Valley.

Role of the Citizens Oversight Committee

The purpose of the Measure E Citizens Oversight Committee is to review and report on the expenditure of taxpayers money for construction, inform the public about the expenditure of bond revenues, and to advise the public as to the district's compliance with the California Constitution and Measure E. The Oversight Committee holds open meetings to review and discuss updates on projects funded by Measure E. The Oversight Committee may: inspect school facilities and grounds to ensure that bond revenues are expended properly, receive and review copies of any deferred maintenance proposals or plans developed by the Gavilan Joint Community College District, and review efforts by the district to maximize bond revenues by implementing cost-saving measures.

Citizens Oversight Committee Members

- Committee Chair:** Douglas Marshall
- Committee Vice Chair:** David Boll
- At-large Representatives:** Elizabeth Sanford, John Sitton, Robert C. Golobic
- Business Organization Representative:** David Boll
- Representative of a college support organization:** Douglas Marshall, Gavilan College Educational Foundation
- Senior Citizens Organization Representative:** John Hansell
- Student active in a college support group:** Fernando Ortiz
- Tax Payer's Organization Representative:** vacant

To serve on the Measure E Citizens Oversight Committee, please fill out application at <http://www.gavilan.edu/bond/coc/citizenscomapplication.pdf>

Meeting dates, agendas, and minutes of past meetings can be found at the website: www.gavilan.edu/bond. For more information or to contact the committee call (408) 848-4711.

Estimated Master Schedule and Project Timeline for remaining projects:

- 2007-2009 Humanities, Art, Music Hall
 - 2008-2010 Cosmetology, Business, Maintenance/Security
 - 2009-2011 Social Science, Gymnasium*
 - 2010-2012 Library*
 - 2011-2013 Student Center*
 - 2012-2014 Occupational Education Phase 2, Parking Lots
- * items with asterisks may be moved forward if state funding becomes available

INDEPENDENT AUDITORS REPORT

The independent audit firm of Vavrinek, Trine, Day & Co., LLP issued a report on December 19, 2008. They found that the financial statements of the Bond Construction Fund of the Gavilan Joint Community College District, "present fairly, in all material respects, the financial position of the Bond Construction Fund, of the Gavilan Joint Community College District at June 30, 2008, and the results of its operations for the year then ended in conformity with accounting principles generally accepted in the United States of America."

Under the modified accrual basis of accounting, liabilities for long-term debt are not reported in the individual funds. However, they are reported as liabilities on the Statement of Net Assets in the Entity Wide financial statements of the Gavilan Joint Community College District.

GENERAL OBLIGATION BONDS HAVE BEEN ISSUED AND ARE OUTSTANDING AS FOLLOWS:

Issue Date	Maturity Date	Interest Rate	Original Issue	Beginning of Year	Issued	Redeemed	End of Year	Due Within One Year
6/10/04	8/1/2028	2.0-5.0%	\$ 29,170,000	\$27,470,000		\$ 1,625,000	\$ 25,845,000	\$ 135,000
12/12/07	8/1/2032	3.03-4.66%	\$ 50,000,000		\$ 50,000,000		\$ 50,000,000	\$ 875,000
Total				\$27,470,000	\$ 50,000,000	\$ 1,625,000	\$ 75,845,000	\$1,010,000

DEBT SERVICE REQUIREMENTS

The 2004, Series A general obligation bonds mature through 2029 as follows:

2004, Series A

Fiscal Year End	Interest to Principal	Maturity	Total
2009	\$ 135,000	\$ 1,321,313	\$ 1,456,313
2010	195,000	1,317,263	1,512,263
2011	265,000	1,310,681	1,575,681
2012	335,000	1,301,738	1,636,738
2013-2017	2,990,000	6,242,950	9,232,950
2018-2022	5,885,000	5,310,895	11,195,895
2023-2027	10,265,000	3,345,675	13,610,675
2028-2029	5,775,000	484,000	6,259,000
Total	\$ 25,845,000	\$ 20,634,515	\$ 46,479,515

The 2004, Series C general obligation bonds mature through 2033 as follows:

2004, Series C

Fiscal Year End	Interest to Principal	Maturity	Total
2009	\$ 875,000	\$ 1,300,271	\$ 2,175,271
2010	105,000	2,293,844	2,398,844
2011	170,000	2,289,644	2,459,644
2012	225,000	2,282,844	2,507,844
2013	300,000	2,273,844	2,573,844
2014-2018	2,840,000	11,120,020	13,960,020
2019-2023	5,715,000	10,296,870	16,011,870
2024-2028	9,725,000	8,568,320	18,293,320
2029-2033	30,045,000	4,829,321	34,874,321
Total	\$50,000,000	\$ 45,254,978	\$ 95,254,978

BOND CONSTRUCTION: STATEMENT OF REVENUES, EXPENDITURES, and CHANGES IN FUND BALANCE

REVENUES	
Local income	\$ 1,602,769
Total Revenues	<u>1,602,769</u>
EXPENDITURES	
Current Expenditures	
Classified salaries	47,924
Employee benefits	17,797
Books and supplies	2,934
Services and operating expenditures	14,037,648
Capital outlay	<u>1,365,687</u>
Total Expenditures	<u>15,471,990</u>
EXCESS OF REVENUES OVER (UNDER) EXPENDITURES	(13,869,221)
OTHER FINANCING SOURCES (USES)	
Opening transfers in	250,000
Bond proceeds	<u>50,000,000</u>
Total other financing resources (Uses)	<u>50,250,000</u>
EXCESS REVENUES AND OTHER FINANCING SOURCES OVER (UNDER) EXPENDITURES AND OTHER USES	36,380,779
FUND BALANCE, BEGINNING OF YEAR	<u>11,799,270</u>
FUND BALANCE, END OF YEAR	<u>\$ 48,180,049</u>

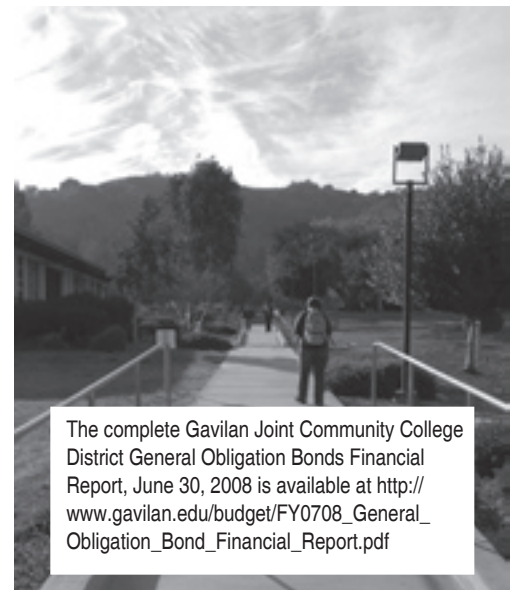

The complete Gavilan Joint Community College District General Obligation Bonds Financial Report, June 30, 2008 is available at http://www.gavilan.edu/budget/FY0708_General_Obligation_Bond_Financial_Report.pdf

GAVILAN COLLEGE



SUMMER BRIDGE '09

What is Summer Bridge?
 This program provides a transition from high school to college and develops academic skills needed for college success. The ultimate goal is to provide students the tools to help them graduate and/or transfer from Gavilan College.

Who is eligible?
 In order to be eligible you must be:
 - Low income, according to financial criteria and a first generation college student (meaning neither parent has earned a college degree).

What are the benefits?
 - Earn 5 college credits. Enroll in two college courses:
 CMUN 10 - Small Group Communications
 GUID 200 - Planning College Success
 - Receive academic support.
 - Make new friends.

How do you apply?
 - Apply to Gavilan College for Summer 2009.
 - Take the Gavilan College Assessment test
 - Apply for Financial Aid (FASFA).
 - Apply for the Board of Governors Fee Waiver.
 - Return your Summer Bridge Application to your high school counselor or mail to: EOPS/TRIO
 Gavilan Community College
 5055 Santa Teresa Blvd.
 Gilroy, CA 95020

For more information:
 Call (408) 848-4772 or (408) 846-4981
www.gavilan.edu/trio/summer

june 15 - july 23

Summer Session

June 15 - July 24, 2009



SIX-WEEK SUMMER SESSION CLASSES BEGIN

Check the class listings for classes beginning earlier and later.

Mon, June 15

LAST DAY TO ADD A CLASS

Unless course is on the Open Entry List or is late-starting.

Tues, June 16 in person until 6 pm online until 11:59 pm

REFUND DEADLINE

For term-long courses.

Fri, June 19

"NRS" DEADLINE

"No Record Shown". Courses dropped by this date do not appear on the student's permanent record. The "NRS" deadline for a short-term course is 30% of the class meetings.

Thurs, June 25

DEADLINE FOR GRADING OPTION

Last day to elect the Pass/No Pass grading option for designated, term-long courses. See Admissions & Records for more information.

Thurs, June 25

INDEPENDENCE DAY HOLIDAY

No day or evening classes.

Fri, July 3

"W" DEADLINE

Courses dropped by this date appear on the student's permanent record with a notation of "W" for withdrawn.

Wed, July 15

FINAL EXAMS

Last day of each class

LAST DAY OF CLASSES

Fri, July 24

Unofficial GRADES

available online

Mon, Aug 3

Official TRANSCRIPTS available

available online at Self-Service Banner

Mon, Aug 10

Counseling Services

are available at the Gavilan main campus on a first-come, first-served basis (walk-ins) beginning May 11. See page 10 for dates and times.

For more information, call the Counseling secretary: 408-848-4723. Photo ID and Gavilan Student ID number required to obtain counseling services.

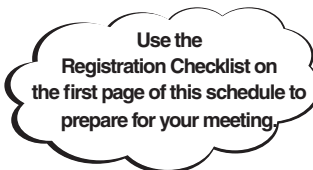

ADD CODES: To add a closed (filled) class once the term has begun, students must obtain an "add code" from the instructor. The "add code" is a four-digit code to be used to register either in person or online. Students may obtain an add code from the instructor before or after the class meeting or during the instructor's office hours.

Classroom Locations: Refer to "How to Use This Schedule" on page 5.

SUMMER SESSION 2009 REGISTRATION

Students must be registered before the first day of an early-start or late-start class.

CALENDAR

PRIORITY REGISTRATION Continuing Students and Veterans* Only.

In person - May 4-8 Online - May 4-10

* Priority registration is granted to any member or former member of the Armed Forces of the United States who is within two years of leaving active duty.

NEW TRANSFER INSTITUTE STUDENTS

In Person only May 7-8

OPEN REGISTRATION New, Continuing, Returning**, and High School Contract Students (High School Contract students must register in person.)

In person/Online May 11 - June 16

Note: No in-person registration on Monday, May 25 (Memorial Day Holiday)

LATE REGISTRATION New, Continuing, Returning** or High School Students

In person/Online June 15-16

Students must be registered by the end of the second day of the term for any six-week class. An add code (issued by the instructor) is required to register for any closed (full) class.

** A "returning" student has been absent from Gavilan College for a semester or more.

WHERE AND WHEN

MAIN CAMPUS

May 4 – 29 Mon-Thurs, 8 am - 4:30 pm; Fri, 9 am - 4:30 pm

Note: No in-person registration on Monday, May 26 (Memorial Day Holiday)

June 1 – June 12 Mon-Thurs, 8 am – 5 pm; Fri, 9 am – 11:30 am

June 15 & 16 Mon, Tues, 8 am – 6 pm

MORGAN HILL AND HOLLISTER SITES

May 1 – 21 Mon-Thurs: 8 am - 8 pm, Fri: 8 am - 5 pm

May 26 – June 12 Mon-Thurs: 8 am - 5:30 pm, Fri: 8 am - 12 noon

June 15 – June 24 Mon-Thurs. 8 am - 8 pm; Fri. 8 am - 12 noon

Notes: Sites are open on Fridays beginning May 29 from 8 am to 12 noon.

May 22 – Closed for Graduation

May 25 – Closed for Memorial Day

July 3 - Friday – Closed for Independence Day Holiday

ONLINE

Go to www.gavilan.edu and click on the Self-Service Banner icon. Follow "Register Online" information above right column.

May 4 at 12:01 am - June 16 at 11:59 pm

REGISTER ONLINE

Go to www.gavilan.edu and click on the Self-Service Banner icon.

New and returning students must have an application on file two working days prior to registering. To register go to www.gavilan.edu and click on the Self-Service Banner icon to get your Gavilan Student ID number and select a user ID and PIN. Register!

High School students register in person.

Add codes required for filled (closed) classes once classes have begun.

Helpline available during in-person registration hours @ 408-848-4733.

Refunds: Refunds of fees in excess of \$10 will be made when term-long courses are officially dropped by June 19. Refunds of less than \$10 will remain on the student's account as a credit unless the Admissions and Records Office is otherwise instructed by the student. Short-term courses must be dropped before 10% of the class meetings have passed. For one- or two-day courses, this date will occur before the start of the course.

Parking Permits must be returned to receive a refund of parking fees.

Adding Courses Students may add courses to their schedules until the end of the second day of the six-week term contingent upon seat availability. To add a course once the course is filled (closed), an add code is required.

Students adding courses with a start date earlier or later than June 15 must be registered by the first day of the class.

Dropping Courses Students may drop courses online at Self-Service Banner or in person. A student who stops attending and does not officially withdraw is not automatically dropped and may receive a final grade of "F" or "NC".

Six-week courses dropped by Thursday, June 25 will not appear on the student's permanent record. Classes dropped between June 26 and July 15 will appear on the permanent record with a notation of "W" (withdrawn).

The "NRS" deadline for a short-term course is 30% of the class meetings.

The "W" deadline for all courses is 75% of the class meetings.

Parking Student parking regulations are enforced Monday through Thursday from 7 a.m. to 10 p.m. and Friday from 7 a.m. to 5 p.m. Student parking is permitted in Lots A, C, E or H except where restricted to staff, visitors or handicapped. All vehicles parked on campus must display a parking permit. Day tickets are available for 75 cents at coin-operated machines in parking lots A & E and at the south entrance to campus. All-day permits are \$20 and are available at the Admissions and Records Office.

ASB cards for the summer session are available for purchase at the Admissions and Records Office on the main campus or at either of the sites.

Basic Fees

- Health Fee \$5
- Student Representation Fee \$1
- Per unit fee (California resident) \$20
- Per unit fee (Non-resident) \$214
- Parking Permits (Required only on the Gilroy campus):
- Day Permit (7 am - 10 pm) \$20
- ASB Card. \$6

Enrollment Fees

*Pay online with American Express, MasterCard, Visa or Discover.
Cash, check, MasterCard or Visa accepted in person.*

Gavilan College is a public institution; the only costs to a California resident are the registration fees, books, and supplies.

# of units	Enrollment Fee	Other Fees *	Total In-State	Total Non-Resident
0.5	10	12	22	119
1.0	20	12	32	226
1.5	30	12	42	333
2.0	40	12	52	440
2.5	50	12	62	547
3.0	60	12	72	654
3.5	70	12	82	761
4.0	80	12	92	868
4.5	90	12	102	975
5.0	100	12	112	1182
5.5	110	12	122	1189
6.0	120	12	132	1296

* Includes health fee (\$5), student representation fee (\$1) and the Associated Student Body ID card (\$6)

Student Body Cards and parking permits are available for sale at the Admissions and Records Office on the main campus or at either the Morgan Hill or Hollister site.

Non-resident students: There is a tuition charge of \$194 per unit in addition to the \$20 per unit enrollment fee, health fee and student representation fee.

Summer Programs

Sports Camps

..... See ad on this page.

College for Youth

..... See ad on page 39.

Digital Media Institute

..... See ad on page 43.

Summer Math Academy

..... See ad on page 47.

Math Boot Camp

..... See ad on page 49.

STAR Program

..... See ad on page 54.



Sports Camps for kids



Gavilan College Community Education
For Registration: <http://gavilan.augusoft.net>
For more info: (408) 848-4876

Softball Camp (Ages 8-13)

Camp was never this much fun! Sign up for our softball camp and have a great time learning the basic fundamentals of the game. Improve your skills while making new friends. This is a great opportunity for the beginner and intermediate athlete. Sign up for this co-ed class now! For more info contact Head Coach, Nikki Dequin at 408-848-4894. Nikki Dequin is the head softball coach at Gavilan College.

M-F, 9:00 am - 12:00 pm; 5 sessions starting 6/22-6/26

Gavilan College Softball Field \$89

Baseball Camp (Ages 8-13)

Join us for a fun week of learning and playing the game of baseball. Its a great chance for the beginner or intermediate ball player to improve offense, defense and pitching skills. Learn new skills, make new friends and have lots of fun in this co-ed camp. For more info, contact Head Coach, Neal Andrade at 408-846-4916. Neal Andrade is the head baseball coach at Gavilan College.

M-F, 9:00 am - 12:00 pm; 5 sessions starting 7/13-7/17

Gavilan College Baseball Field \$99

Volleyball Camp (Ages 8-13)

Learn the fundamentals necessary to become competitive in volleyball. Players will develop a focus on hitting, setting, serving, passing and digging. You will test your newly developed skills in game-like situations. This is a co-ed class.

M-Th, 9:00 am - 11:00 am; 4 sessions starting 7/20-7/23

Room: Bill Christopher Court - Main Gym \$89

Volleyball Camp (Ages 13-17)

Learn the fundamentals necessary to become competitive in volleyball. Players will develop a focus on hitting, setting, serving, passing and digging. You will test your newly developed skills in game-like situations. This is a co-ed class.

M-Th, 11:00 am - 1:00 pm; 4 sessions starting 7/20-7/23

Room: Bill Christopher Court - Main Gym \$89

Summer Distance Education Courses



Online courses allow students who have access to a computer with an internet connection to take college credit classes. Students must have an email account before they register for the online course. Students will meet their instructors and classmates online. Your instructor may schedule one or more optional meetings on campus.

After enrolling online, start the class by going to

<http://www.gavilan.edu/disted/>

BE SURE TO NOTE THE STARTING DATE OF YOUR CLASS. Unless you have made prior arrangements with the instructor, you MUST login by 11:59 pm on the first day of the semester for full-term courses or the first day of class for short-term courses. Late adds must login within 24 hours of adding this course. If you miss the deadline you may be dropped. For help, contact your instructor or email disted@gavilan.edu

ORIENTATIONS: We strongly recommend students take one of the live orientations to online courses offered in the Gavilan Library. Please see the library homepage at: <http://www.gavilan.edu/library/> for a schedule of orientations.

CRN	COURSE	DESCRIPTION	UNITS	BEGIN/END	INSTRUCTOR	CRN	COURSE	DESCRIPTION	UNITS	BEGIN/END	INSTRUCTOR
80210	AH 11	NUTRITION	3	6/15-7/24	Martha Akrop	80011	ENGL 1A**	COMPOSITION	3	6/15--8/8	Debbie Luoma
80179	ANTH 1	INTRO PHYSICAL ANTH	3	6/15-7/24	Debra Klein	80021	ENGL 1B**	COMPOSITION & LIT	3	6/15-8/8	Kyle Hull
80184	ANTH 1	INTRO PHYSICAL ANTH	3	6/15-7/24	Debra Klein	80024	ENGL 1B**	COMPOSITION & LIT	3	6/15-8/8	Jennifer Raimondo
80059	ART 6	ART APPRECIATION	3	6/15-7/24	Jane Edberg	80027	ENGL 1C	CRITIC REASON/WRITE	3	6/15-7/24	Karen Wisdom
80061	ART 6	ART APPRECIATION	3	6/15-7/24	Jane Edberg	80374	ENGL 1C	CRITIC REASON/WRITE	3	6/15-7/24	Cheryl Chaffin
80211	BIO 11	NUTRITION	3	6/15-7/24	Martha Akrop	80351	GUID 1*	SELF ASSESSMENT	3	5/22-6/12	Rosa Sharboneau
80380	CD 2	EARLY CHILD DEVELOP	3	6/15-7/24	Marlene Bumgarner	80020	GUID 1	SELF ASSESSMENT	3	6/15-7/24	Leslie Tenney
80430	CD 2	EARLY CHILD DEVELOP	3	6/15-7/24	Randy Brown	80350	GUID 1	SELF ASSESSMENT	3	6/15-7/24	Johanna Stewart
80226	CD 3	CHILD GROWTH/DEV	3	6/15-7/24	Marlene Bumgarner	80036	GUID 6	LIFE SKILLS HIGHER ED	2	6/15-7/24	Celia Marquez
80386	CD 3	CHILD GROWTH/DEV	3	6/15-7/24	Mary Hoshiko	80133	LIB 3**	RESEARCH SKILLS	2	6/15-8/7	Dana Young
80134	CSIS 3**	RESEARCH SKILLS	2	6/15-8/7	Dana Young	80263	LIB 732***	INTRO TO ONLINE GAVILAN	0	6/15-7/24	Joy Parker
80411	CSIS 7	WEB PAGE AUTHOR II	2	6/15-7/9	Dennie Van Tassel	80193	POLS 1	INTRO AMERICAN GOVERNMENT	3	6/15-7/24	Marc Turetzky
80180	CSIS 12**	ASSEMBLY LANGUAGE	3	6/15-8/7	Dennie Van Tassel	80195	POLS 1	INTRO AMERICAN GOVERNMENT	3	6/15-7/24	Marc Turetzky
80253	CSIS 12**	ASSEMBLY LANGUAGE	3	7/6-8/28	Dennie Van Tassel	80196	POLS 1	INTRO AMERICAN GOVERNMENT	3	6/15-7/24	Marc Turetzky
80186	CSIS 12L**	ASSEMBLY LANG LAB	1	6/15-8/7	Dennie Van Tassel	80381	PSYC 2	EARLY CHILD DEVELOP	3	6/15-7/24	
80409	CSIS 12L**	ASSEMBLY LANG LAB	1	7/6-8/28	Dennie Van Tassel	80431	PSYC 2	EARLY CHILD DEVELOP	3	6/15-7/24	Randy Brown
80085	CSIS 45**	C++ PROGRAMMING I	4	6/15-8/7	Dennie Van Tassel	80228	PSYC 3	CHILD GROWTH/DEV	3	6/15-7/24	Marlene Bumgarner
80410	CSIS 45**	C++ PROGRAMMING I	4	7/6-8/28	Dennie Van Tassel	80432	PSYC 3	CHILD GROWTH/DEV	3	6/15-7/24	Mary Hoshiko
80399	CSIS 84**	JAVASCRIPT PROGRAM	2	6/15-8/7	Dennie Van Tassel	80353	PSYC 5*	SELF ASSESSMENT	3	5/22-6/12	Rosa Sharboneau
80445	CSIS 84**	JAVASCRIPT PROGRAM	2	7/6-8/28	Dennie Van Tassel	80010	PSYC 5	SELF ASSESSMENT	3	6/15-7/24	Johanna Stewart
80152	CSIS 151	INTRO XML AUTHOR	3	6/15-8/7	Dennie Van Tassel	80029	PSYC 5	SELF ASSESSMENT	3	6/15-7/24	Leslie Tenney
80444	DM 7	WEB PAGE AUTHOR II	2	6/15-7/09	Dennie Van Tassel	80201	SOC 1A	INTRO TO SOCIOLOGY	3	6/15-7/24	Robin Kreider
80408	ECON 1**	PRIN MACROECONOMICS	3	6/15-8/15	Bon-Tai Truongson	80428	SOC 1A	INTRO TO SOCIOLOGY	3	6/15-7/24	Robin Kreider
80004	ENGL 1A	COMPOSITION	3	6/15-7/24	Erin Crook	80289	SPAN 12A	SPAN/SPAN SPEAKERS	5	6/15-7/24	David Perez
80373	ENGL 1A	COMPOSITION	3	6/15-7/24	Steve Schessler						

- * Early start class. Check start date.
- ** Late-start and/or extended session
- *** Noncredit Class

GoPrint You can now use the GoPrint system to print documents at all of Gavilan College's computer labs. No need to fumble around with coins! With your GoPrint or ASB card, you're good to go. See ad on page 8.



Hybrid

Hybrid classes will be delivered partially online and also meet face to face at select locations. You must have an email account to take a distance ed course. Unless you have made prior arrangements with the instructor, come to class in person on the first day of the semester or the first day of class for short-term courses. If you do not show up on the first day you may be dropped. For help, contact your instructor or email disted@gavilan.edu.

CRN	COURSE	DESCRIPTION	UNITS	BEGIN/END	INSTRUCTOR
80367	BIO 15	SURVEY ANAT/PHYSIOL plus an in-person lab TWR, 310-615 in LS103	5	6/15-7/24	Rey Morales
80368	BIO 15	SURVEY ANAT/PHYSIOL plus an in-person lab TWR, 630-935 in LS103	5	6/15-7/24	Rey Morales
80460	CSIS 128	DATABASE - MS ACCESS plus an in-person lecture M, 600-905 in Morgan Hill - MHG8	2	7/13-8/17	Frank Thompson



Hollister Courses

Gavilan College Hollister Site at the Briggs Building
 365 Fourth St.
 Hollister, CA 95023
 (831) 636-3783

Morgan Hill Courses

Gavilan College at the Morgan Hill Community and Cultural Center
 17060 Monterey Rd.
 Morgan Hill, CA 95037
 (408) 782-2873



Morgan Hill and Hollister Summer Hours:

May 1 - 21 Mon-Thurs: 8 am - 8 pm, Fri, 8 am - 5 pm
Note: Closed Friday, May 22
 May 26 - June 12 Mon-Thurs: 8 am - 5:30 pm, Fri, 8 am - 12 noon
 June 15 - July 24 Mon-Thurs: 8 am - 8 pm, Fri, 8 am - 12 noon

Notes: Sites are open on Fridays beginning May 29 from 8 am to 12 noon.
 May 22 - Closed for Graduation
 May 25 - Closed for Memorial Day
 July 3 - Friday - Closed for Independence Day Holiday

HOLLISTER COURSES:

CRN	COURSE	DESCRIPTION	UNITS	DAYS	TIMES	DATES	ROOM
80218	AMT 123	INDEPENDENT STUDY	1	Day/time	- see instructor	6/15-7/24	AV102*
80221	AMT 123	INDEPENDENT STUDY	2	Day/time	- see instructor	6/15-7/24	AV102*
80012	BOT 180	MEDICAL TERM/OFFICE	3	MWF	9:30A-1:30P	6/1-6/26	HOL2
80382	CD 20	CHILDREN'S LAN/LIT	3	MWF	9:00A-12:00P	6/15-7/24	HOL5
80406	CSIS 122	COMPUTER KEYBOARD	0.5	F	5:30P-9:40P	6/15-7/24	HOL3
80450	CSIS 124	WINDOWS FUND	1	TuTh	6:00P-9:05P	7/14-7/30	HOL3
80393	CSIS 126	WORD PROCESS-MS WRD	2	MW	5:30P-8:15P	6/15-7/24	HOL3
80148	CSIS 728**	WINDOWS FOR THE OA	0	TuTh	3:31P-4:30P	6/15-7/24	HOL3
80013	ENGL 1A	COMPOSITION	3	MWTh	6:00P-8:05P	6/15-8/8	HOL1
80071	ENGL 756**	GED PREPARATION	0	Sat	8:30A-12:30P	6/15-7/24	HOL3
80400	ESL 780**	ESL LIFESKILLS 4	0	MWF	6:00P-7:30P	6/15-7/24	HOL4
80401	ESL 780**	ESL LIFESKILLS 4	0	MWF	7:45P-9:15P	6/15-7/24	HOL4
80352	GUID 6	LIFE SKILLS HIGHER ED	2	TuWTh	9:30A-11:30P	6/15-7/24	HOL1
80106	LIB 730**	INTERNET LITERACY	0	TuTh	2:31P-3:30P	6/15-7/24	HOL3
80065	LIB 733**	EXPLORING THE WEB	0	TuTh	1:30P-2:30P	6/15-7/24	HOL3
80423	MATH 205A	FIRST HALF ALGEBRA	2.5	Daily	12:00P-3:20P	6/15-7/10	HOL4
80424	MATH 205B	SECOND HALF ALGEBRA	2.5	Daily	12:00P-3:20P	7/13-8/7	HOL4
80425	MATH 233A	FIRST HALF INT ALG	2.5	Daily	8:00A-11:20A	6/15-7/11	HOL4
80426	MATH 233B	SECOND HALF INT ALG	2.5	Daily	8:00A-11:20A	7/13-8/8	HOL4
80202	SOC 3	RACE AND ETHNICITY	3	TuWTh	6:00P-8:50P	6/15-7/24	HOL2

* Meets at Gavilan College Aviation Department, 490 Skylane Drive, Hollister Airport, Hollister.
 ** Noncredit class.

MORGAN HILL COURSES:

CRN	COURSE	DESCRIPTION	UNITS	DAYS	TIMES	DATES	ROOM
80449	ACCT 20	FINANCIAL ACCT	4	MWF	9:00A-11:40A	6/22-8/7	MHG12
80075	ART 25A	ART METHODS	3	MTuWTh	8:30A-12:35P	6/15-7/24	MHG3
80077	ART 25B	CONCEPT ART METHODS	3	MTuWTh	8:30A-12:35P	6/15-7/24	MHG3
80421	BUS 1	FUND OF BUSINESS	3	MW	6:00P-9:05P	6/15-8/05	MHG10
80078	CD 25A	ART METHODS	3	MTuWTh	8:30A-12:35P	6/15-7/24	MHG3
80079	CD 25B	CONCEPT ART METHODS	3	MTuWTh	8:30A-12:35P	6/15-7/24	MHG3
80090	CMUN 1A	INTRO PUBLIC SPEAK	3	TuWTh	6:00P-9:10P	6/15-7/24	MHG4
80390	CSIS 6	WEBPAGE AUTHORIZING I	2	MWTh	4:10P-6:55P	6/15-7/9	MHG8
80084	CSIS 10	BASIC PROGRAMMING	2	MWTh	7:00P-9:50P	6/15-7/9	MHG8
80460	CSIS 128	DATABASE-MS ACCESS	2	M	6:00P-9:05P	7/13-8/31	MHG8
80442	DM 6	WEBPAGE AUTHORIZING I	2	MWTh	4:10P-6:55P	6/15-7/9	MHG8
80009	ENGL 1A	COMPOSITION	3	MTuTh	10:30A-12:35P	6/15-8/8	MHG11
80453	ESL 702A**	ESL CITIZENSHIP	0	MW	9:00A-11:30A	6/15-7/24	MHG5
80309	ESL 777**	ESL LIFESKILLS 1	0	TuTh	6:00P-8:30P	6/15-7/24	MHG13
80398	ESL 778**	ESL LIFESKILLS 2	0	TuTh	9:00A-11:30A	6/15-7/24	MHG12
80443	LIB 6	WEBPAGE AUTHORIZING I	2	MWTh	4:10P-6:55P	6/15-7/9	MHG8
80163	MATH 5	INTRO STATISTICS	3	MTuWTh	6:00P-8:50P	6/15-7/24	MHG3
80177	MATH 233	INTERMED ALGEBRA	5	MTuWTh	8:30A-11:45A	6/15-7/24	MHG13
80197	PSYC 1A	INTRO TO PSYCHOLOGY	3	MTuWTh	10:30A-12:35P	6/15-7/24	MHG4
80391	RE 160	REAL ESTATE PRINC	3	Sat	8:30A-12:30P	6/6-8/22	MHG12

** Noncredit class.

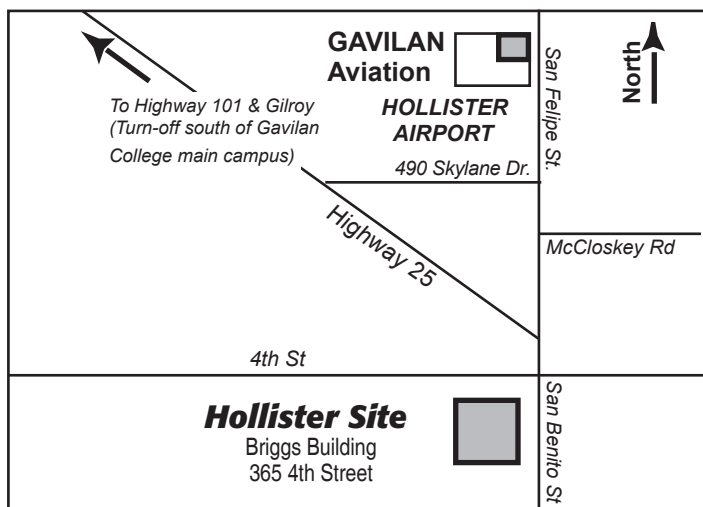

Gavilan College offers courses that meet in Morgan Hill and Hollister, including some that meet on weekends and/or start late in the term. Students may register for classes online or at any of the sites: Gilroy, Hollister or Morgan Hill.

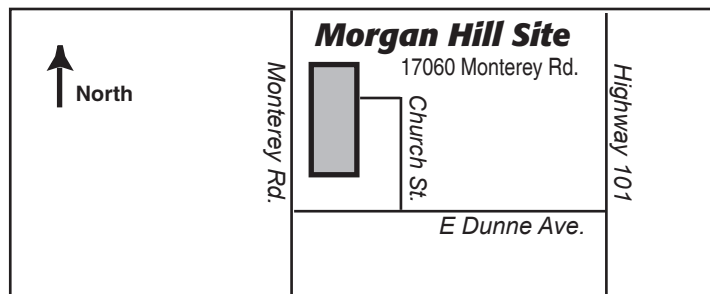

Classroom Locations: Refer to "How to Use This Schedule" on page 5.

Summer Classes

CRN Type Room Instructor Hrs. Units Days Begin-End

ACCOUNTING

ACCT 20 Financial Accounting

Transferable: CSU, UC; CAN:BUS2, BUS SEQ A

An introduction to accounting principles and concepts. The course includes the application of accounting theory to accumulate and summarize financial data. This course has the option of a letter grade or pass/no pass. ADVISORY: Eligible for English 250, English 260 and Mathematics 233. Microsoft Excel or other computer spreadsheet knowledge.

80449 Lec MHG12 Barta M 9.0 4.0 MWF 0900-1140
06/22/09 - 08/07/09

ACCT 103 General Office Accounting

Transferable: CSU

This course is designed to prepare students for entry-level office accounting positions. Emphasis is on practical accounting applications. This course has the option of a letter grade or pass/no pass. ADVISORY: Eligible for Mathematics 205.

80005 L/L BU118 College A 9.0 2.0 MWR 0600-0840

ADMINISTRATION OF JUSTICE

AJ 10 Introduction to the Administration of Justice

Transferable: CSU, UC; CAN:AJ2

The history and philosophy of justice as it evolved throughout the world; in-depth study of the American system and various sub-systems; roles and role expectations of criminal justice agents in their interrelationships in society; concepts of crime causations, punishments and rehabilitation; ethics, education and training for professionalism in the social system. ADVISORY: Eligible for English 250 and English 260.

80205 Lec BU120 Pulido D 9.0 3.0 MTR 0630-0920

ALLIED HEALTH

AH 11 Nutrition

Transferable: CSU, UC; CSU-GE:E2; GAV-GE:E2, F; CAN:FCS2

This course is designed to meet the needs of the Allied Health student and the general education student alike. The major aim of this course is to help the student acquire relevant information about nutrition which they can use professionally and/or personally. The course will cover the practical aspects of normal nutrition, ways to promote sound eating habits throughout the life cycle, and physiological contribution nutrients make to body structure and function. This course is also listed as BIO 11. PREREQUISITE: Eligible for English 250 and English 260. ADVISORY: Chemistry 30A and Mathematics 205.

80210 ONLINE Akrop M 3.0

 You must have an email account to take this course. Start your course by going to www.gavilan.edu/disted. Unless you have made prior arrangements with the instructor, you MUST login by 11:59 pm on the first day of the class. Late adds must login within 24 hours of adding this course. If you miss the deadline you may be dropped. For help, contact your instructor or email disted@gavilan.edu

CRN Type Room Instructor Hrs. Units Days Begin-End

AH 32 Basic Cardiac Life Support

Transferable: CSU

Course designed to teach students skills in adult, child and infant cardiopulmonary resuscitation. Specifically designed for health professionals. Successful completion will result in certification by the American Heart Association or American Red Cross. This is a pass/no pass course. May be repeated up to three times for credit. Additional \$5.00 due upon completion for certification card.

80372 Lec HOB114 Logan C 18.0 1.0 WR 0900-0600
06/03/09 - 06/04/09 \$12 course materials fee

80212 Lec HOB114 Logan C 18.0 1.0 WR 0900-0600
08/26/09 - 08/27/09 \$12 course materials fee.

ANTHROPOLOGY

ANTH 1 Introduction to Physical Anthropology

Transferable: CSU, UC; CSU-GE:B2, IGETC:5B; GAV-GE:B2; CAN:ANTH2

Explores and analyzes human biological, social and cultural development over the last several million years. The implications of evolutionary theory for the world today are considered. Principal topics are evolutionary theory, Mendelian and molecular genetics, the fossil record, primatology, the nature of human diversity, biocultural analysis of malnutrition, and the question of continuing evolution. ADVISORY: English 250, English 260 and Mathematics 205.

80182 Lec SS210 Etlar D 9.2 3.0 MTWR 1030-1235

 The following two distance ed classes will be delivered entirely over the internet. You must have an email account to take these courses. Start your course by going to www.gavilan.edu/disted. Unless you have made prior arrangements with the instructor, you MUST login by 11:59 pm on the first day of the class. Late adds must login within 24 hours of adding this course. If you miss the deadline you may be dropped. For help, contact your instructor or email disted@gavilan.edu

80179 ONLINE Klein D 3.0
This class will be delivered entirely over the internet. See statement above.

80184 ONLINE Klein D 3.0
This class will be delivered entirely over the internet. See statement above.

ANTH 2 Introduction to Archaeology

Transferable: CSU, UC; CSU-GE:D1, IGETC:4A; GAV-GE:D2

Introduction to history and development of the concepts and methods of anthropological archaeology, a survey of selected prehistoric cultures, and some training in archaeological survey methods, site recognition, recordation and preservation as well as cultural resource management. ADVISORY: Recommended English 250 and English 260.

80375 Lec SS210 Etlar D 9.2 3.0 MTWR 0230-0435

ART

ART 1B Art History

Transferable: CSU, UC; CSU-GE:C1; IGETC:3A; GAV-GE:C1; CAN:ART4, ART SEQ A

The history of western painting, sculpture, architecture and minor arts from the Romanesque, the Gothic and Renaissance eras to the present. ADVISORY: Eligible for English 250 and English 260.

80459 Lec PB5 Staff 9.2 3.0 MTWR 1030A-1235P

ART 3A Drawing and Composition

Transferable: CSU, UC; CSU-GE:C1; GAV-GE:C1; CAN:ART8

A course that can teach you how to draw. Students learn basic drawing skills through the exploration of a variety of drawing materials such as pencil, inks, charcoal and pastels; processes include doodling, gesture and schematic drawing.

80384 Lec PB8 Webster E 17.2 3.0 MTWR 0830-1235

Your educational plan:

You are expected to take the responsibility for scheduling an appointment with a counselor, preferably at least once a semester. The purpose of this appointment is to develop, review and update your educational plan to ensure that you are taking the appropriate courses to meet your educational goal.

CRN Type Room Instructor Hrs. Units Days Begin-End

ART 6 Art Appreciation

Transferable: CSU, UC; CSU-GE:C1, IGETC:3A; GAV-GE:C1

An illustrated lecture course that surveys and introduces the visual arts from historical to contemporary times, and teaches students the basic concepts of seeing and appreciating art. ADVISORY: English 250 and English 260.

The following two distance ed classes will be delivered entirely over the internet. You must have an email account to take these courses. Start your course by going to www.gavilan.edu/disted. Unless you have made prior arrangements with the instructor, you **MUST** login by 11:59 pm on the first day of the class. Late adds must login within 24 hours of adding this course. If you miss the deadline you may be dropped. For help, contact your instructor or email disted@gavilan.edu

80059	ONLINE		Edberg J	3.0			
This class will be delivered entirely over the internet. See statement above.							
80061	ONLINE		Edberg J	3.0			
This class will be delivered entirely over the internet. See statement above.							

ART 10A Cultural History of Ceramics

Transferable: CSU, UC; CSU-GE:C1; GAV-GE:C1, F; CAN:ART6

An introduction to the historical developments and cultural influences of ceramic art. Development of a personal expression is realized through the combination of historical elements, observation and actual creations in clay.

80067	L/L	PB9	Rekedal J	15.2	3.0	MTWR	0830-1235
-------	-----	-----	-----------	------	-----	------	-----------

ART 10B Ceramics

Transferable: CSU, UC; GAV-GE:C1

Emphasis on development of wheel throwing and advanced ceramic techniques. Glaze testing, clay body development, kiln stacking and firing are introduced. May be repeated three times for credit. This course has the option of a letter grade or pass/no pass. ADVISORY: Art 10A

80068	L/L	PB9	Rekedal J	17.2	3.0	MTWR	0830-1235
-------	-----	-----	-----------	------	-----	------	-----------

ART 23 Independent Study

Transferable: CSU

Designed to afford selected students specialized opportunities for exploring areas at the independent study level. The courses may involve extensive library work, research in the community, or special projects. May be repeated until six units of credit are accrued. This course has the option of a letter grade or pass/no pass. REQUIRED: The study outline prepared by the student and the instructor must be filed with the department and the dean.

80070	Ind	PB9	Rekedal J	1.0			
80073	Ind	PB9	Rekedal J	2.0			

ART 25A Art Methods

Transferable: CSU; CSU-GE:C1; GAV-GE:C1

Art methods and learning theory for those planning to work with preschool, elementary and secondary school students. Includes art therapy as well as gifted and special learner projects. Two dimensional work in printing, drawing, collage. Also listed as CD 25A.

80075	L/L	MHG3	Rios S	15.6	3.0	MTWR	0830-1235
Above class meets at Morgan Hill Community site.							

ART 25B Art Methods

Transferable: CSU; GAV-GE:C1

Art methods, creativity and learning theory for those planning to work with preschool, elementary, and secondary school students. Includes art therapy as well as gifted and special learner projects. Three dimensional work in sculpture, bas relief, mobiles, paper mache', plaster, and various 3-D materials. Also listed as CD 25B.

80077	L/L	MHG3	Rios S	15.6	3.0	MTWR	0830-1235
Above class meets at Morgan Hill Community site.							

ART 85 Web Design I: Dreamweaver

Transferable: CSU; GAV-GE:C1

Basic and intermediate principles of designing Web pages/sites using the Dreamweaver web design software and HTML. Emphasis will be on good design and the use of tables, frames, forms, rollovers, DHTML, XHTML, behaviors, and CSS. Also includes site maintenance and the integration of multimedia components such as graphics, sound, animation, and video. This course is for the content person to design, develop, and maintain effective Web sites. This course is also listed as CSIS 85 and DM 85. This course has the option of a letter grade or pass/no pass. May be repeated twice for credit. ADVISORY: CSIS 6 or basic knowledge of HTML.

80394	Lec	BU111	Howell P	6.6	2.0	TR	0900-1205
-------	-----	-------	----------	-----	-----	----	-----------

CRN Type Room Instructor Hrs. Units Days Begin-End

AVIATION MAINTENANCE TECHNOLOGY

AMT 123 Independent Study

Transferable: CSU

Designed to afford selected students specialized opportunities for exploring areas at the independent study level. The courses may involve extensive library work, research in the community, or special projects. May be repeated until six units of credit are accrued. This course has the option of a letter grade or pass/no pass. REQUIRED: The study outline prepared by the student and the instructor must be filed with the department and the dean. Meets at Gavilan College Aviation Department, 490 Skylane Drive, Hollister Airport, Hollister.

80218	Ind	AV102	Flippen T	1.0			
Above class meets at the Hollister Airport.							
80221	Ind	AV102	TBA	2.0			
Above class meets at the Hollister Airport.							

BIOLOGICAL SCIENCE

BIO 8 General Microbiology

Transferable: CSU, UC; CSU-GE:B2, B3, IGETC:5B; GAV-GE:B2, B3; CAN:BIOL14

An introduction to microbiology with an emphasis on bacteriology. Includes the study of morphology, physiology and classification of microorganisms, a survey of infectious disease, immunology and techniques for culture and control of microorganisms. This course is also listed as Allied Health 8. PREREQUISITE: Biological Science 10 or 15 with a grade of credit or C or better. ADVISORY: Chemistry 30A; eligible for English 250, English 260 and Mathematics 205.

80383	L/L	LS103	Kim L	16.0	5.0	MTWR	1110-0300
06/15/09-08/08/09							

BIO 10 Principles of Biology

Transferable: CSU, UC; CSU-GE:B2, B3, IGETC:5B; GAV-GE:B2, B3

An introductory biology course covering functions at the cellular and organismal levels. Includes study of the basic principles of metabolism, heredity, evolution and ecology. Primarily for non-biological science majors. ADVISORY: Eligible for English 250, English 260 and Mathematics 205.

80365	Lec	LS101	Keys S	9.0	4.0	TRF	1010-0100
	Lab	LS102	Keys S	6.0		TRF	0810-1000
80366	Lec	LS101	Keys S	9.0	4.0	TRF	1010-0100
	Lab	LS102	Keys S	6.0		TRF	0110-0300

BIO 11 Nutrition

Transferable: CSU, UC; CSU-GE:E2; GAV-GE:E2, F; CAN:FCS2

This course is designed to meet the needs of the Allied Health student and the general education student alike. The major aim of this course is to help the student acquire relevant information about nutrition which they can use professionally and/or personally. The course will cover the practical aspects of normal nutrition, ways to promote sound eating habits throughout the life cycle, and physiological contribution nutrients make to body structure and function. This course is also listed as Allied Health 11. PREREQUISITE: Eligible for English 250 and English 260 ADVISORY: Chemistry 30A and Mathematics 205.

80211	ONLINE		Akrop M	3.0			
You must have an email account to take this course. Start your course by going to www.gavilan.edu/disted . Unless you have made prior arrangements with the instructor, you MUST login by 11:59 pm on the first day of the class. Late adds must login within 24 hours of adding this course. If you miss the deadline you may be dropped. For help, contact your instructor or email disted@gavilan.edu .							

BIO 15 Survey of Human Anatomy and Physiology

Transferable: CSU, UC; CSU-GE:B2, B3, IGETC:5B; GAV-GE:B2, B3

An introductory study of the structure and function of the human body. Includes study at the cellular and organ system levels, emphasizing integration of systems. Note that a cadaver will be observed in this course. This course is also listed as Allied Health 15. ADVISORY: Biological Science 10, Eligible for English 250, English 260 and Mathematics 205. Course will include the viewing of a cadaver.

The following two distance ed (hybrid) classes will be delivered partially online and also meet face to face at select locations. You must have an email account to take a distance ed course. Unless you have made prior arrangements with the instructor, come to class in person on the first day of the class. If you do not show up on the first day you may be dropped. For help, contact your instructor or email disted@gavilan.edu.

80367	ONLINE		Morales R	5.0			
	Lab	LS103	Morales R	9.9		TWR	0310-0615
80368	ONLINE		Morales R	5.0			
	Lab	LS103	Morales R	9.9		TWR	0630-0935

CRN Type Room Instructor Hrs. Units Days Begin-End

BUSINESS OFFICE TECHNOLOGY

BOT 112 Business Computations with Machines

Transferable: CSU

Self-paced course in the operation of the electronic printing calculator. This course provides theory and practice in business applications with emphasis on mathematical problem solving. This course has the option of a letter grade or pass/no pass. May be repeated three times for credit. ADVISORY: Eligible for Mathematics 402.

80294 Lab BU110 Gaffney S 12.0 .5 MTWR 1000-0100
07/13/09 - 07/23/09

BOT 180 Medical Terminology for the Office

Transferable: CSU

This course introduces fundamentals of medical word building used in the health profession (prefixes, word roots, suffixes and abbreviations) as well as review of body systems, with emphasis on analysis, definition, spelling and pronunciation. This course has the option of a letter grade or pass/no pass. ADVISORY: Eligible for English 250 and English 260.

80012 Lec HOL2 Hardcastle C 6.0 3.0 MWF 0930-0130
06/01/09 - 06/26/09 Above class meets at the Hollister Briggs site.

BUSINESS, GENERAL

BUS 1 Fundamentals of Business

Transferable: CSU, UC; GAV-GE:D2

This course introduces students to business and the array of opportunities that it offers. The course will help students recognize careers that will be of interest to them with consideration of their own skills and aptitudes. Different facets of business will be covered and students will learn about establishing their own business. This course has the option of a letter grade or pass/no pass. Previously listed as GBUS 1. ADVISORY: Eligible for English 250 and English 260.

80421 Lec MHG10 Staff 6.6 3.0 MW 0600-0905
06/15/09 - 08/05/09 Above class meets at Morgan Hill Community site.

CHEMISTRY

CHEM 30A Elementary Chemistry

Transferable: CSU, UC; CSU-GE:B1, B3, IGETC:5A; GAV-GE:B1, B3; CAN:CHEM6, CHEM SEQ B

This is a first semester college chemistry course designed for majors preparing to take Chemistry 1A, nursing and allied health students, as well as general education. The course will cover the principles of chemistry including properties of matter, energy, atomic theory, the Periodic Table, stoichiometry, elements and compounds, the properties of bonding, molecular structure, chemical reactions, states of matter, acidity, solutions and gases, as well as an introductory to organic chemistry. ADVISORY: Mathematics 205; eligible for English 250 and English 260.

80246 L/L CH105 Clark D 8.0 4.0 MTWR 0900-1100
L/L CH101 Clark D 11.2 MTWR 1130-0200

CHILD DEVELOPMENT

CD 2 Early Child Development

Transferable: CSU, UC; CSU-GE:D9, E, IGETC:4I; GAV-GE:D2

A systematic study of the child from prenatal life through the preschool years. The course integrates the basic concepts of physical, cognitive and psychosocial development at each major stage of life during this period. This course is also listed as PSYC 2. This course has the option of a letter grade or pass/no pass. ADVISORY: Eligible for English 250 and English 260; transfer students consult with advisor.

The following two distance ed classes will be delivered entirely over the internet. You must have an email account to take these courses. Start your course by going to www.gavilan.edu/disted. Unless you have made prior arrangements with the instructor, you MUST login by 11:59 pm on the first day of the class. Late adds must login within 24 hours of adding this course. If you miss the deadline you may be dropped. For help, contact your instructor or email disted@gavilan.edu.

80380 ONLINE Bumgarner M 3.0
This online class will be delivered entirely over the Internet. See statement above.

80430 ONLINE Brown R 3.0
This online class will be delivered entirely over the Internet. See statement above.

Short term, Not-for-Credit Classes

SUMMER 2009



Classes include:

- Arts & Crafts
- Foreign Languages
- English/Language Arts
- Math
- Money Management
- Science
- Study Skills and more!

Summer Sessions:

Session 1 Mon-Thurs 6/29-7/10

Session 2 Mon-Thurs 7/13-7/23

Dates subject to change. Course fees vary.

Choose from morning or afternoon block sessions.

ART 10A/B



CERAMICS

Play dirty!

Hands-on studio work with historical and contemporary approaches.

Art 10A/B 80067/80068 MTuWTh 8:30 am -12:35 pm

CRN Type Room Instructor Hrs. Units Days Begin-End

CD 3 Child Growth and Development During the School Years

Transferable: CSU, UC; CSU-GE:D9, E, IGETC:4I; GAV-GE:D2

Continuation of the study of the principles of child development with emphasis on children from six years through adolescence. Includes developmental theories and topics relevant to these ages. This course is also listed as PSYC 3. This course has the option of a letter grade or pass/no pass. ADVISORY: Eligible for English 250 and English 260; Child Development 2; transfer students consult with advisor.

The following two distance ed classes will be delivered entirely over the internet. You must have an email account to take these courses. Start your course by going to www.gavilan.edu/disted. Unless you have made prior arrangements with the instructor, you MUST login by 11:59 pm on the first day of the class. Late adds must login within 24 hours of adding this course. If you miss the deadline you may be dropped. For help, contact your instructor or email disted@gavilan.edu.

80386 ONLINE Hoshiko M 3.0
This online class will be delivered entirely over the Internet. See statement above.

80226 ONLINE Bumgarner M 3.0
This online class will be delivered entirely over the Internet. See statement above.

CD 19 Introduction to Careers with Children

Transferable: CSU

An overview of Department of Social Services and Department of Education regulations regarding child care workers in California. Self-assessment techniques with emphasis on teacher-child and teacher-adult relationships and personal evaluations. Basic principles of curriculum development and discipline techniques. This course has the option of a letter grade or pass/no pass. ADVISORY: Eligible for English 250 and English 260.

80379 Lec BU118 Henrickson P 6.0 2.0 TR 0900-1200

CRN Type Room Instructor Hrs. Units Days Begin-End

CD 20 Children's Language and Literature

Transferable: CSU

A developmental view of children's language and literacy learning in a framework of children's literature. Students will be presented with steps in children's literacy learning in order to help them organize classrooms and plan activities to support the growth of writing and reading. Students will study historical trends in children's literature and participate in practical experiences and activities that use a wide range of techniques and materials for advancing language comprehension and usage. This course has the option of a letter grade or pass/no pass. ADVISORY: Eligible for English 250 and English 260.

80382 Lec HOL5 Muscari D 9.0 3.0 MWF 0900-1200
Above class meets at the Hollister Briggs site.

CD 25A Art Methods

Transferable: CSU; CSU-GE:C1; GAV-GE:C1

Art methods and learning theory for those planning to work with preschool, elementary and secondary students. Includes art therapy as well as gifted and special learner projects. Two dimensional work in printing, painting, drawing, collage. Also listed as ART 25A.

80078 L/L MHG3 Rios S 15.6 3.0 MTWR 0830-1235
Above class meets at Morgan Hill Community site.

CD 25B Art Methods

Transferable: CSU; GAV-GE:C1

Art methods, creativity and learning theory for those planning to work with preschool, elementary, and secondary school students. Includes art therapy as well as gifted and special learner projects. Three dimensional work in sculpture, bas relief, mobiles, paper mache', plaster, and various 3-D materials. Also listed as ART 25B.

80079 L/L MHG3 Rios S 15.6 3.0 MTWR 0830-1235
Above class meets at Morgan Hill Community site.

CD 28A Child Dev & Guidance for Family Child Care/ Foster Care

Transferable: CSU

An overview of the development of young children from pre-birth through age twelve, primarily designed for the family child care provider or foster parent. Students will be exposed to appropriate expectations and developmentally appropriate learning experiences for each stage of development. Six 3-hour sessions, or may be taught on three Saturdays. This course has the option of a letter grade or pass/no pass.

80376 Lec CDC127 Alonzo S 12.0 1.0 MTWR 0600-0900
06/01/09 - 06/09/09

CD 28B Dev Learning Activities for Family Child Care & Foster Care

Transferable: CSU

A practical curriculum development course for child care providers. The course includes a brief overview of children's learning processes and practical activities. Students will study appropriate curriculum for infants, toddlers, preschool, and school-age children in all areas of development. Students will learn how to set up a family child care environment. This course has the option of a letter grade or pass/no pass

80377 Lec CDC127 Alonzo S 12.0 1.0 MTWR 0600-0900
06/15/09 - 06/23/09

CD 28C Administering A Family Child Care Home

Transferable: CSU

Learning to establish and enforce contracts and policies, marketing your business, being professional in a caring profession, child abuse reporting requirements, licensing regulations for family child care, and the basics of record keeping techniques for family child care. Six 3-hour sessions, or may be taught on three Saturdays. This course has the option of a letter grade or pass/no pass.

80378 Lec CDC127 Alonzo S 12.0 1.0 MTWR 0600-0900
07/01/09 - 07/09/09

CRN Type Room Instructor Hrs. Units Days Begin-End

CD 219 Spanish Introduction to Child Development at Gavilan College

Transferable: No

This course will orient mono-lingual (Spanish) Child Development students to Gavilan College and the Child Development and Educational Studies (CDES) departments. Students will be provided an overview of campus academic and support services and programs, explore the professional opportunities in the field of Child Development and learn effective strategies for college success. This course has the option of a letter grade or pass/no pass.

80385 Lec GOKIDS TBA 3.0 1.0 T 0630-0910
Above class meets at Go Kids Inc., 885 Moro Dr., Gilroy. This class is taught in Spanish. (Esta clase se enseña en Español).

COMMUNICATION STUDIES

CMUN 1A Introduction to Public Speaking

Transferable: CSU, UC; CSU-GE:A1, IGETC:1C; GAV-GE:A1; CAN:SPCH4

Basic principles of effective human communication and their function in contemporary public settings; emphasis is on the speech to inform, with special consideration given to fundamental communication skills, including organization, reasoning, explanation and listening. ADVISORY: Eligible for English 250 and English 260.

80088 Lec PB3 Cowan D 9.2 3.0 MTWR 1030-1235

80090 Lec MHG4 Cnuddle R 10.2 3.0 TWR 0600-0910
Above class meets at Morgan Hill Community site.

CMUN 10 Small Group Communication

Transferable: CSU, UC; CSU-GE:A1, IGETC:1C; GAV-GE:A1; CAN:SPCH10

An introductory course that develops basic individual reasoning skills, insights and experiences in information-sharing, interacting, decision-making, problem-solving, resolution of disputes and other issues central to group processes. ADVISORY: Eligible for English 250 and English 260.

80096 Lec PB3 Cowan D 9.2 3.0 MTWR 0800-1005

80091 Lec PB1 Waddell E 9.2 3.0 MTWR 0800-1005
This class is part of the Summer Bridge Program. See ad on page 32. Students must also enroll in GUID 200, CRN 80261. Additional requirement: Students will participate in a University visit on Friday, July 17th from 9 am - 3 pm.

80363 Lec PB1 Waddell E 9.2 3.0 MTWR 1030-1235
This class is part of the Summer Bridge Program. See ad on page 32. Students must also enroll in GUID 200, CRN 80354. Additional requirement: Students will participate in a University visit on Friday, July 17th from 9 am - 3 pm.

CMUN 129 Presentation Graphics - MS Powerpoint

Transferable: CSU

This introductory course in presentation graphics will use Microsoft Office's "PowerPoint" software to create a computerized presentation with text and objects. This course has the option of a letter grade or pass/no pass. May be repeated three times for credit. This course is also listed as CSIS 129. ADVISORY: CSIS 126 or word processing skills in the Windows environment.

80207 Lec BU110 Gaffney S 16.0 1.0 MTWR 0900-0100
07/15/09 - 07/23/09

COMPUTER SCIENCE & INFORMATION SYSTEMS

CSIS 1 Computer Literacy - MS Office

Transferable: CSU, UC; GAV-GE:E2; CAN:CSC12

An introduction to terminology, design, operation for the novice user. Student will gain experience using the Internet for searches and email. They will complete projects using various software including word processing, spreadsheets, database, presentation graphics, and integration. This course has the option of a letter grade or pass/no pass. ADVISORY: Eligible for English 250 and English 260; completion of CSIS 122.

80015 Lec BU110 Littig A 6.6 2.0 MW 0600-0905

Summer Final Exams

are the last day of each class.

What is a **CRN**?

CRN stands for Course Reference Number. This is the number (used to be called section) that you will use to register for your classes.

CRN Type Room Instructor Hrs. Units Days Begin-End

CSIS 3 Research Skills

Transferable: CSU

Research and evaluation skills using the Internet and other electronic resources, as well as traditional printed materials. Also listed as LIB 3. This course has the option of a letter grade or pass/no pass. May be repeated once for credit. ADVISORY: Eligible for English 250 and 260.

80134 Online ONLINE Young D 2.0
 06/15/09 - 08/07/09 You must have an email account to take this course. Start your course by going to www.gavilan.edu/disted. Unless you have made prior arrangements with the instructor, you MUST login by 11:59 pm on the first day of the class. Late adds must login within 24 hours of adding this course. If you miss the deadline you may be dropped. For help, contact your instructor or email disted@gavilan.edu.

CSIS 6 Web Page Authoring I

Transferable: CSU; GAV-GE:E2

An introduction to using Hypertext Mark-Up Language (HTML) and Extensible HTML (XHTML) to create web pages which can be uploaded and displayed on the World Wide Web. Students will use HTML/XHTML to create web pages with text in various sizes and colors, links to other sites, background color or patterns, graphics, tables and mailto links. Principles of design and color as they apply to screen presentations will be included. This course has the option of a letter grade or pass/no pass. May be repeated three times for credit. Also listed as LIB 6 and DM 6. ADVISORY: CSIS 1 or CSIS 2 or CSIS 3/LIB 3 advised.

80390 Lec MHG8 Van Tassel D 8.7 2.0 MWR 0410-0655
 06/15/09 - 07/09/09 Above class meets at Morgan Hill Community site.

CSIS 7 Web Page Authoring II

Transferable: CSU

This course is a continuation of CSIS 6, Web Page Authoring I. Topics that will be covered include XHTML, frames, advanced tables, forms, scripting languages, image maps, Cascading Style Sheets (CSS), and new trends in web page technology. This course has the option of a letter grade or pass/no pass. May be repeated three times for credit. This course is also listed as DM 7. ADVISORY: CSIS 6

80411 ONLINE Van Tassel D 2.0
 06/15/09 - 07/09/09 You must have an email account to take this course. Start your course by going to www.gavilan.edu/disted. Unless you have made prior arrangements with the instructor, you MUST login by 11:59 pm on the first day of the class. Late adds must login within 24 hours of adding this course. If you miss the deadline you may be dropped. For help, contact your instructor or email disted@gavilan.edu.

CSIS 10 BASIC Programming

Transferable: CSU, UC

This course is an introduction to programming using BASIC. No previous programming background is assumed. This is a good class for those new to programming and recommended for non-programmers that want to take other programming classes. This course has the option of a letter grade or pass/no pass. ADVISORY: CSIS 1 or CSIS 2 or equivalent experience.

80084 Lec MHG8 Van Tassel D 9.0 2.0 MWR 0700-0950
 Above class meets at Morgan Hill Community site.

CSIS 12 Assembly Language Programming

Transferable: CSU, UC

Fundamentals of assembly language programming concepts and techniques. Topics include internal representation of data, arithmetic operations, logic statements, and general assembly language commands. Introduce low level language architecture including assemblers, linkage editors, and loaders. This course has the option of a letter grade or pass/no pass. COREQUISITE: CSIS 12L Assembly Language Programming Lab ADVISORY: CSIS 45 (C++ Programming) or programming experience. Math 233 (Intermediate Algebra)

The following two distance ed classes will be delivered entirely over the internet. You must have an email account to take these courses. Start your course by going to www.gavilan.edu/disted. Unless you have made prior arrangements with the instructor, you MUST login by 11:59 pm on the first day of the class. Late adds must login within 24 hours of adding this course. If you miss the deadline you may be dropped. For help, contact your instructor or email disted@gavilan.edu.

80180 ONLINE Van Tassel D 3.0
 06/15/09 - 08/07/09 This online class will be delivered entirely over the Internet. See statement above.

80253 ONLINE Van Tassel D 3.0
 07/06/09 - 08/28/09 This online class will be delivered entirely over the Internet. See statement above.



CSIS 1

2 UNITS

Computer Literacy MS Office

An Introduction to MS Office

CSIS 10 BASIC Programming

An introductory course for those students exploring a computer programming career.

Instructor: Dennie Van Tassel

CSIS 10 is transferable to UC and CSU



Brush Up your Software Skills

Most Computer Applications classes are repeatable.

UPDATE YOUR COMMUNICATION SKILLS!!

ADD **WEB PAGE CONSTRUCTION** TO YOUR COMMUNICATIONS TOOLBOX!

CSIS/DM/LIB 6 WebPage Authoring I

The basic skills of webpage construction

CSIS/DM 7 Web Page Authoring II

SEE YOU IN THE COMPUTER LABS!!

CSIS 129

Presentation Graphics - MS Powerpoint

1 unit - 2 week course



CRN 80207 Instructor: Sandra Gaffney MTuWTh 9 am - 1 pm

Dates: 7/15- 7/23

Also listed as CMUN 129

CRN Type Room Instructor Hrs. Units Days Begin-End

CSIS 12L Assembly Language Programming Lab

Transferable: CSU, UC

Supplemental practice in coursework associated with this course is provided. Concurrent enrollment in CSIS 12 is required. This is a pass/no pass course. COREQUISITE: CSIS 12 Assembly Language Programming

The following two distance ed classes will be delivered entirely over the internet. You must have an email account to take these courses. Start your course by going to www.gavilan.edu/disted. Unless you have made prior arrangements with the instructor, you MUST login by 11:59 pm on the first day of the class. Late adds must login within 24 hours of adding this course. If you miss the deadline you may be dropped. For help, contact your instructor or email disted@gavilan.edu.

80186	ONLINE		Van Tassel D	1.0			
06/15/09 - 08/07/09 This online class will be delivered entirely over the Internet. See statement above.							
80409	ONLINE		Van Tassel D	1.0			
07/06/09 - 08/28/09 This online class will be delivered entirely over the Internet. See statement above.							

CSIS 45 C++ Programming I

Transferable: CSU, UC; GAV-GE:E2; CAN:CSCI18

An introduction to the concepts and methods of computer programming using C++. Students will be introduced to procedural and object-oriented programming design methodology. Topics covered include variable and constant declarations, selection statements, repetition, functions and recursion, arrays, strings, pointers, and an introduction to classes and objects. This course will prepare students for the Programming II class. This course has the option of a letter grade or pass/no pass. ADVISORY: CSIS 10 or equivalent. Math 205 (Elementary Algebra)

The following two distance ed classes will be delivered entirely over the internet. You must have an email account to take these courses. Start your course by going to www.gavilan.edu/disted. Unless you have made prior arrangements with the instructor, you MUST login by 11:59 pm on the first day of the class. Late adds must login within 24 hours of adding this course. If you miss the deadline you may be dropped. For help, contact your instructor or email disted@gavilan.edu.

80085	ONLINE		Van Tassel D	4.0			
06/15/09 - 08/07/09 This online class will be delivered entirely over the Internet. See statement above.							
80410	ONLINE		Van Tassel D	4.0			
07/06/09 - 08/28/09 This online class will be delivered entirely over the Internet. See statement above.							

CSIS 84 JavaScript Programming

Transferable: CSU, UC

Fundamentals of JavaScript client-side programming for Web pages requiring data collection or other user interaction. Students will create Web pages that execute on the client (personal system) using JavaScript. This course may be repeated one time for credit. This course has the option of a letter grade or pass/no pass. ADVISORY: CSIS 6

The following two distance ed classes will be delivered entirely over the internet. You must have an email account to take these courses. Start your course by going to www.gavilan.edu/disted. Unless you have made prior arrangements with the instructor, you MUST login by 11:59 pm on the first day of the class. Late adds must login within 24 hours of adding this course. If you miss the deadline you may be dropped. For help, contact your instructor or email disted@gavilan.edu.

80399	ONLINE		Van Tassel D	2.0			
06/15/09 - 08/07/09 This online class will be delivered entirely over the Internet. See statement above.							
80445	ONLINE		Van Tassel D	2.0			
07/06/09 - 08/28/09 This online class will be delivered entirely over the Internet. See statement above.							

CSIS 85 Web Design I: Dreamweaver

Transferable: CSU; GAV-GE:C1

Basic and intermediate principles of designing Web pages/sites using the Dreamweaver web design software and HTML. Emphasis will be on good design and the use of tables, frames, forms, rollovers, DHTML, XHTML, behaviors, and CSS. Also includes site maintenance and the integration of multimedia components such as graphics, sound, animation, and video. This course is for the content person to design, develop, and maintain effective Web sites. This course is also listed as ART 85 and DM 85. This course has the option of a grade or pass/no pass. May be repeated twice for credit. ADVISORY: CSIS 6 or basic knowledge of HTML.

80395	Lec	BU111	Howell P	6.6	2.0	TR	0900-1205
-------	-----	-------	----------	-----	-----	----	-----------

CRN Type Room Instructor Hrs. Units Days Begin-End

CSIS 122 Computer Keyboarding

Transferable: CSU

A self-paced course for students who wish to master the alphabetic and numeric keyboard on the computer. This course is designed for students who do not know the alphabetic keyboard by "touch" and for those who want to improve their ability to type straight copy with increased speed and accuracy. The course provides "hands-on" instruction to help students reach optimum computer keyboarding skills within a limited time. This is a pass/no pass course. Course may be repeated until 3 units are accrued.

80124	Lab	BU110	Gaffney S	8.0	.5	MTWR	0910-1100
Orientation required. Schedule available in BU 110. Gavilan Business/Computer Lab hours in BU 110: DAY students from 9 a.m. - 1 p.m. Monday-Thursday. Open entry-open exit.							
80127	Lab	BU110	Gaffney S	16.0	1.0	MTWR	0910-0100
Orientation required. Schedule available in BU 110. Gavilan Business/Computer Lab hours in BU 110: DAY students from 9 a.m. - 1 p.m., Monday - Thursday. Open entry-open exit.							
80132	Lab	BU110	Milar E	8.0	.5	MTWR	1110-0100
Orientation required. Schedule available in BU 110. Gavilan Business/Computer Lab hours in BU 110: DAY students from 9 a.m. - 1 p.m., Monday - Thursday. Open entry-open exit.							
80296	Lab	BU110	Milar E	8.0	1.0	MTWR	1110-0100
Orientation required. Schedule available in BU 110. Gavilan Business/Computer Lab hours in BU 110: DAY students from 9 a.m. - 1 p.m., Monday - Thursday. Open entry-open exit.							
80406	Lab	HOL3	Mendez F	4.4	.5	F	0530-0940
Above class meets at the Hollister Briggs site.							

CSIS 124 Windows Fundamentals

Transferable: CSU

This course provides fundamental information on the Windows environment for the computer. Introductory Windows operations and file management are covered. This is a pass/no pass course. This course may be repeated three times for credit. ADVISORY: Basic keyboarding skill.

80404	Lec	BU110	Milar E	16.0	1.0	MTWR	0900-0100
06/22/09 - 06/29/09							
80450	Lec	HOL3	Thompson F	16.0	1.0	TR	0600-0905
07/14/09 - 07/30/09 Above class meets at the Hollister Briggs site.							

CSIS 126 Word Processing - MS Word

Transferable: CSU

This introductory course for word processing with Windows is designed for business and non-business majors. Students will develop word processing skills to create a document, select and edit text, move and copy text, use the spelling, grammar, and thesaurus features, format text, and create headers, footnotes for a research paper. This course has the option of a letter grade or pass/no pass and may be repeated when the software changes. ADVISORY: Eligible for English 260 and basic keyboarding skills.

80405	Lec	BU110	Gaffney S	16.0	2.0	MTWR	0900-0100
06/30/09 - 07/14/09							
80393	Lec	HOL3	Mendez F	5.8	2.0	MW	0530-0815
Above class meets at the Hollister Briggs site.							

CSIS 128 Database - MS Access

Transferable: CSU

Introduction to Microsoft Access, a relational database management software tool. Students will learn to create and manage a database. This course will help prepare students for taking the Access MOUS (Microsoft Office User Specialist) exams. May be repeated three times for credit. This course has the option of a letter grade or pass/no pass. ADVISORY: CSIS 1 or CSIS 2 or equivalent knowledge.

80460	Lec	MHG8	Thompson F	6.60	2.0	M	0600P-0905P
ONLINE							
07/13/09 - 08/17/09 This distance ed (hybrid) class will be delivered partially online and also meet face to face at select locations. Above class meets at the Morgan Hill Community site. You must have an email account to take a distance ed course. Unless you have made prior arrangements with the instructor, come to class in person on the first day of the class. If you do not show up on the first day you may be dropped. For help, contact your instructor or email disted@gavilan.edu .							

CSIS 129 Presentation Graphics - MS PowerPoint

Transferable: CSU

This introductory course in presentation graphics will use Microsoft Office's "PowerPoint" software to create a computerized presentation (slide show) with text and objects. This course is also listed as CMUN 129. This course has the option of a letter grade or pass/no pass. May be repeated three times for credit. ADVISORY: CSIS 126 or word processing skills in the Windows environment.

80150	Lec	BU110	Gaffney S	16.0	1.0	MTWR	0900-0100
07/15/09 - 07/23/09							

CRN Type Room Instructor Hrs. Units Days Begin-End

CSIS 151 Introduction to XML Authoring

Transferable: CSU

This course provides an introduction and overview of eXtensible Markup Language (XML) and XML related technologies used to develop content and manipulate data for commercial web sites. XML is a revolutionary language which is rapidly becoming a Web development standard for business-to-business transactions, and for database manipulation and searching. The class will cover well-formed and valid XML documents, namespaces, schemas, cascading style sheets (CSS), and XSLT. This course has the option of a letter grade or pass/no pass. May be repeated three times for credit. ADVISORY: CSIS 6

80152 ONLINE Van Tassel D 3.0
 06/15/09 - 08/07/09 You must have an email account to take this course. Start your course by going to www.gavilan.edu/disted. Unless you have made prior arrangements with the instructor, you **MUST** login by 11:59 pm on the first day of the class. Late adds must login within 24 hours of adding this course. If you miss the deadline you may be dropped. For help, contact your instructor or email disted@gavilan.edu.

CSIS 570 Computer Access Evaluation

Transferable: No

This course is intended to provide an in-depth computer access evaluation in order to determine an appropriate access environment for a student with a disability or multiple disabilities. This is a pass/no pass course. May be repeated as necessary based on measurable progress as documented in the Student Educational Contract. This is an open entry, open exit course. ADVISORY: This course is intended for students with a verified disability who show a need for the use of assistive computer programs and/or equipment or demonstrated academic deficit.

80360 Lab LI105 Maringer J .5 Day/Time - see instructor

CSIS 571 Computer Assisted Instruction

Transferable: No

This course is an Assistive Computer Technology Lab designed for students who are eligible for Disability Services. The course is designed to improve basic academic skills and/or cognitive processes through the use of appropriate software or to learn assistive devices designed to make computers accessible. Course content is based on Student Educational Contracts which are developed for each student. This is a pass/no pass course. May be repeated as necessary based on measurable progress as documented in the Student Educational Contract. This is an open entry, open exit course. ADVISORY: This course is intended for students with a verified disability who show a need for the use of adaptive computer programs and/or equipment or demonstrated academic deficit.

80361 Lab LI105 Maringer J .5 Day/Time - see instructor

COSMETOLOGY

COS 207 Contemporary Styling

Transferable: No

Studies and techniques in braiding, weaving, glass nails, silk wrap, individual lash and brow tinting, corrective make-up and low lights. This is a 6 week class offered in summer session only. May be repeated once for credit. ADVISORY: Satisfactory completion of Cosmetology 200. Eligible for English 250, 260, and Mathematics 205. Intermediate and Advanced cosmetology enrollments only.

80236 L/L COS109 Hernandez R 35.2 4.5 MTWR 0800-0430
 06/08/09 - 07/16/09

80243 L/L COS109 Andre M 35.2 4.5 MTWR 0800-0430
 Khanna N
 06/08/09 - 07/16/09 This class is taught by two instructors.

COS 223 Independent Study

Transferable: No

Designed to afford selected students specialized opportunities for exploring areas at the independent study level. The courses may involve extensive library work, research in the community, or special projects. May be repeated until six units of credit are accrued. This course has the option of a letter grade or pass/no pass. REQUIRED: The study outline prepared by the student and the instructor must be filed with the Department and the Area Dean.

80260 Ind COS109 TBA 2.0

Summer Final Exams are the last day of each class.

Institute for Digital Media Entertainment & Education
 The '09 Summer of Digital Storytelling

Listen to guest Storytellers, then tell your own story digitally using:

- Digital Video (Film)
- Digital Photography
- 2D & 3D Animation
- Your Web site
- Presentation
- Podcast



June 16 - July 18, register for DM 108 Open Lab
www.gavilan.edu/DigitalMedia

DIGITAL MEDIA

Visit the Gavilan Bookstore

on the Gilroy main campus early. Used books may be available at reduced cost.

SUMMER HOURS

Mon-Thurs: 8 am - 3 pm
 Friday: 8 am - 1 pm

EXTENDED SUMMER HOURS

During the first week of summer session the bookstore will remain open Monday-Thursday until 7 pm, Friday until 5:30 pm.

CRN Type Room Instructor Hrs. Units Days Begin-End

DIGITAL MEDIA

DM 6 Web Page Authoring I

Transferable: CSU; GAV-GE:E2

An introduction to using Hypertext Mark-Up Language (HTML) and Extensible HTML (XHTML) to create web pages which can be uploaded and displayed on the World Wide Web. Students will use HTML/XHTML to create web pages with text in various sizes and colors, links to other sites, background color or patterns, graphics, tables and mailto links. Principles of design and color as they apply to screen presentations will be included. This course has the option of a letter grade or pass/no pass. May be repeated three times for credit. Also listed as CSIS 6 and LIB 6. ADVISORY: CSIS 1 or CSIS 2 or CSIS 3/LIB 3 advised.

80442 Lec MHG8 Van Tassel D 8.7 2.0 MWR 0410-0655
 06/15/09 - 07/09/09 Above class meets at Morgan Hill Community site.

DM 7 Web Page Authoring II

Transferable: CSU

This course is a continuation of CSIS 6, Web Page Authoring I. Topics that will be covered include XHTML, frames, advanced tables, forms, scripting languages, image maps, Cascading Style Sheets (CSS), and new trends in web page technology. This course has the option of a letter grade or pass/no pass. May be repeated three times for credit. This course is also listed as CSIS 7. ADVISORY: CSIS 6

80444 ONLINE Van Tassel D 2.0
 06/15/09 - 07/09/09 You must have an email account to take this course. Start your course by going to www.gavilan.edu/disted. Unless you have made prior arrangements with the instructor, you **MUST** login by 11:59 pm on the first day of the class. Late adds must login within 24 hours of adding this course. If you miss the deadline you may be dropped. For help, contact your instructor or email disted@gavilan.edu.

DM 85 Web Design I: Dreamweaver

Transferable: CSU; GAV-GE:C1

Basic and intermediate principles of designing Web pages/sites using the Dreamweaver web design software and HTML. Emphasis will be on good design and the use of tables, frames, forms, rollovers, DHTML, XHTML, behaviors, and CSS. Also includes site maintenance and the integration of multimedia components such as graphics, sound, animation, and video. This course is for the content person to design, develop, and maintain effective Web sites. This course is also listed as ART 85 and CSIS 85. This course has the option of a letter grade or pass/no pass. May be repeated twice for credit. ADVISORY: CSIS 6 or basic knowledge of HTML.

80387 Lec BU111 Howell P 6.6 2.0 TR 0900-1205

CRN Type Room Instructor Hrs. Units Days Begin-End

DM 108 Digital Media Lab

Transferable: CSU; GAV-GE:C1

Supervised practice and individualized computer assisted learning or software applications and techniques commonly found in the design and production of digital media (e.g., digital art and imaging, digital photography, digital print, digital audio/video, web design design/authoring, DVD/CD ROMs, animation). Supplements lecture courses. Open entry/exit, so may be added anytime during the semester. This is a pass/no pass course. Also listed as ART 108 and CSIS 108. May be repeated three times for credit. ADVISORY: CSIS 1 or CSIS 2/2L or equivalent computer experience.

80388 Lab LI128 Beede R 7.6 .5 MTWR 1000-1145
07/06/09 - 07/30/09

80389 Lab LI128 Beede R 7.6 .5 MTWR 1200-0145
07/06/09 - 07/30/09

ECONOMICS

ECON 1 Principles of Macroeconomics

Transferable: CSU, UC; CSU-GE:D2, IGETC:4B; GAV-GE:D2; CAN:ECON2

Introduction to the principles of macroeconomics, social organization of the economy; supply and demand; the determinants of national income and production, economic growth, the global economy and trade, employment, prices, savings and investment; the nature and effectiveness of monetary and fiscal policy. This course has the option of a letter grade or pass/no pass. ADVISORY: Eligible for English 1A and Mathematics 233.

80408 ONLINE Truongson B 3.0
06/15/09 - 08/15/09 You must have an email account to take this course. Start your course by going to www.gavilan.edu/disted. Unless you have made prior arrangements with the instructor, you MUST login by 11:59 pm on the first day of the class. Late adds must login within 24 hours of adding this course. If you miss the deadline you may be dropped. For help, contact your instructor or email disted@gavilan.edu.

ENGLISH

ENGL 1A Composition

Transferable: CSU, UC; CSU-GE:A2, IGETC:1A; GAV-GE:A2; CAN:ENGL2, ENGL SEQ A

This is a writing course which emphasizes expository writing, argumentative writing, and critical reading of expository prose. It is meant to train students in clear thinking and reasoned support of ideas. Students will be given the opportunity to read models of good expository and argumentative prose and learn the techniques of good writing. These include choosing appropriate subjects, developing restricted, unified, and precise theses and presenting supporting evidence in a logical, lucid, and effective manner. To achieve this end, students write no fewer than six essays and read at least five works, two of which are book length. PREREQUISITE: English 250 and English 260 or English 250 and SSCI 270A or English 250 and SSCI 270B with a grade of 'C' or better or satisfactory score on the English placement examination.

80003 Lec PB16 Pirani A 9.2 3.0 MTWR 0800-1005

80009 Lec MHG11 Gatewood J 9.2 3.0 MTR 1030-1235
06/15/09 - 08/08/09 Above class meets at Morgan Hill Community site.

80013 Lec HOL1 Mora G 6.9 3.0 MWR 0600-0805
06/15/09 - 08/08/09 Above class meets at the Hollister Briggs site.

The following three distance ed classes will be delivered entirely over the internet. You must have an email account to take these courses. Start your course by going to www.gavilan.edu/disted. Unless you have made prior arrangements with the instructor, you MUST login by 11:59 pm on the first day of the class. Late adds must login within 24 hours of adding this course. If you miss the deadline you may be dropped. For help, contact your instructor or email disted@gavilan.edu.

80004 ONLINE Crook E 3.0
This online class will be delivered entirely over the Internet. See statement above.

80011 ONLINE Luoma D 3.0
06/15/09 - 08/08/09 This online class will be delivered entirely over the Internet. See statement above.

80373 ONLINE Schessler S 3.0
This online class will be delivered entirely over the Internet. See statement above.

CRN Type Room Instructor Hrs. Units Days Begin-End

ENGL 1B Composition and Literature

Transferable: CSU, UC; CSU-GE:C, IGETC:3B; GAV-GE:C2; CAN:ENGL4, ENGL SEQ A

English 1B continues the work begun in 1A, but now the emphasis shifts to writing expository prose in conjunction with reading and analyzing imaginative literature. Students are to write as fledgling critics and use the text as a basis for other forms of reflection. The reading requirement includes short stories, poetry, drama, and at least two novels. Course work will also include fundamentals of research writing. PREREQUISITE: English 1A with a grade of "C" or better.

80017 Lec SS111 Brett T 9.2 3.0 MTWR 0800-1005

The following two distance ed classes will be delivered entirely over the internet. You must have an email account to take these courses. Start your course by going to www.gavilan.edu/disted. Unless you have made prior arrangements with the instructor, you MUST login by 11:59 pm on the first day of the class. Late adds must login within 24 hours of adding this course. If you miss the deadline you may be dropped. For help, contact your instructor or email disted@gavilan.edu.

80021 ONLINE Hull K 3.0
06/15/09 - 08/08/09 This online class will be delivered entirely over the Internet. See statement above.

80024 ONLINE Raimondo J 3.0
06/15/09 - 08/08/09 This online class will be delivered entirely over the Internet. See statement above.

ENGL 1C Critical Reasoning and Writing

Transferable: CSU, UC; CSU-GE:A3, IGETC:1B; GAV-GE:C2

This course is designed to develop critical thinking, reading, and writing skills beyond the level achieved in English 1A. The emphasis is on critical analysis of arguments and the development of the ability to integrate the principles of critical thinking into essay writing. PREREQUISITE: English 1A with a grade of "C" or better.

80025 Lec SS111 Brett T 9.2 3.0 MTWR 1030-1235

The following two distance ed classes will be delivered entirely over the internet. You must have an email account to take these courses. Start your course by going to www.gavilan.edu/disted. Unless you have made prior arrangements with the instructor, you MUST login by 11:59 pm on the first day of the class. Late adds must login within 24 hours of adding this course. If you miss the deadline you may be dropped. For help, contact your instructor or email disted@gavilan.edu.

80027 ONLINE Wisdom K 3.0
This online class will be delivered entirely over the Internet. See statement above.

80374 ONLINE Chaffin C 3.0
This online class will be delivered entirely over the Internet. See statement above.

ADVISORY: Due to the the large volume of reading and writing required in English 1A and 1B, some classes will be offered over eight weeks instead of six. All English classes at the 200 and 400 level will also be offered over eight weeks.

ENGL 250 Practical Writing

Transferable: No; GAV-GE:A2

This course covers writing clear, correct, effective essays and learning preliminary research skills. PREREQUISITE: English 440 or ESL 563 with a grade of 'C' or better or satisfactory score on the English placement examination.

80429 Lec SS205 Sandler S 6.8 3.0 MR 0800-1110
Lab LI120 Sandler S 2.2 T 0800-0950
06/15/09 - 08/08/09

80433 Lec SS205 Sandler S 6.8 3.0 MR 0800-1110
Lab LI120 Sandler S 2.2 W 0800-0950
06/15/09 - 08/08/09

80434 Lec SS205 Frazier S 6.8 3.0 MR 1120-0230
Lab LI120 Frazier S 2.2 T 1120-0110
06/15/09 - 08/08/09

80435 Lec SS205 Frazier S 6.8 3.0 MR 1120-0230
Lab LI120 Frazier S 2.2 W 1120-0110
06/15/09 - 08/08/09

80436 L/L SS111 White S 6.8 3.0 MR 0600-0910
Lab LI120 White S 2.2 T 0600-0750
06/15/09 - 08/08/09

80437 Lec SS111 White S 6.8 3.0 MR 0600-0910
Lab LI120 White S 2.2 W 0600-0750
06/15/09 - 08/08/09

Have you met the prerequisite?
It's required!

CRN Type Room Instructor Hrs. Units Days Begin-End

ENGL 260 Preparation for College Reading

Transferable: No; GAV-GE:A3

This is a course presenting strategies in the technique and practice of college level critical reading and thinking skills. PREREQUISITE: Completion of English 420 or ESL 562 with a grade of 'C' or better or Assessment recommendation.

80037 Lec PB4 Luoma D 6.9 3.0 MTW 0800-1005
06/15/09 - 08/08/09

ENGL 420 Reading Improvement

Transferable: No

This is a practical, "how to" course teaching various methods of learning and reading college material. Using group and individual instruction in vocabulary, comprehension, and study skills, the students will increase their ability to survive academically, to profit, grow and succeed in all college courses, and to enjoy reading and learning. Units earned in this course do not count toward the associate degree and/or certain certificate requirements. PREREQUISITE: Satisfactory score on the English placement examination.

80438 Lec SS203 Withers M 6.8 3.0 MR 0800-1110
Lab LI171 Withers M 2.2 T 0800-0950
06/15/09 - 08/08/09

80439 Lec SS203 Withers M 6.8 3.0 MR 0800-1110
Lab LI171 Withers M 2.2 W 0800-0950
06/15/09 - 08/08/09

ENGL 440 Basic Writing

Transferable: No

This is an intensive study and application of basic grammar, sentence, and essay writing skills within the context of composing short essays. Units earned in this course do not count toward the associate degree and/or certain certificate requirements. PREREQUISITE: Satisfactory score on the English placement examination.

80440 Lec SS203 Roscher J 6.8 3.0 MR 1120-0230
Lab LI171 Roscher J 2.2 T 1120-0110
06/15/09 - 08/08/09

80441 Lec SS203 Roscher J 6.8 3.0 MR 1120-0230
Lab LI171 Roscher J 2.2 W 1120-0110
06/15/09 - 08/08/09

ENGLISH AS A SECOND LANGUAGE

All new ESL students must go through the ESL assessment process. See page 134.

Todos los nuevos estudiantes de ESL deben tomar el examen de nivelación de ESL. Consulte la página 134.

ESL 501B Survival ESL I Second Half

Transferable: No

This is a second half of a course in survival English for students with little or no oral or written English competency. It will give students basic vocabulary and familiarity in life skill areas such as the family, food, health, and occupations. The course integrates listening, speaking, reading, and writing. (ESL 501, 502, and 503 are sequential courses that may be taken in full form or in halves, preferably A before B.) This is a pass/no pass course. ADVISORY: ESL 501A or ESL assessment recommendation

80046 L/L LI100 Cisneros N 14.4 3.0 MTWR 0900-1220

ESL 502B Survival ESL II Second Half

Transferable: No

This is the second half of the second course in survival English for students with little oral or written English competency. It will give students expanded basic vocabulary and familiarity in life skill areas such as weather, transportation, employment, and American holidays and customs. The course integrates listening, speaking, reading, writing. (ESL 501, 502, and 503 are sequential courses that may be taken in full form or in halves, preferably A before B.) This is a pass/no pass course. ADVISORY: ESL 501 or ESL 501A and 501B or ESL assessment recommendation

80049 L/L PH102 Baameur K 14.4 3.0 MTWR 0900-1220

CRN Type Room Instructor Hrs. Units Days Begin-End

ESL 581 ESL Pronunciation I

Transferable: No

This is a high-beginning/low-intermediate ESL Pronunciation Course. Students will participate in a variety of communicative activities designed to improve their pronunciation. This course focuses on clear pronunciation of vowels, consonants, diphthongs and clusters, accurate word stress and rhythm, and the connection between spelling and pronunciation. It also introduces the concept of sentence intonation. This is a pass/no pass course. ADVISORY: ESL 510B or ESL Assessment Test Recommendation.

80050 L/L BU119 Polizzotto J 6.0 2.0 MWR 0900-1100

ESL 582 ESL Pronunciation II

Transferable: No

ESL Pronunciation II is the second in a series of courses designed to give ESL students extra practice with their pronunciation. After reviewing vowel and consonant sounds, students will approach pronunciation through use of word stress, sentence rhythm, and discourse intonation. This is a pass/no pass course. ADVISORY: ESL 531, ESL 581, or ESL assessment recommendation.

80052 L/L BU119 Polizzotto J 6.0 2.0 MWR 1145-0145

ESL 584 Culture Through Film

Transferable: No

This course is designed to practice listening and speaking skills through the use of selected films. The course highlights different intercultural issues and aspects of American culture, and students enhance their listening and speaking skills by means of authentic discourse. Because film provides a real sample of speech in a multi-dimensional experience, ESL learners can experience the language in a more complete manner while analyzing cultural issues. This is a pass/no pass course. ADVISORY: ESL 541 or ESL Assessment recommendation.

80370 Lec SS110 Guzman D 9.2 3.0 MTWR 0900-1105

GEOLOGY

GEOL 1 Introduction to Geology

Transferable: CSU, UC; CSU-GE:B1, B3, IGETC:5A; GAV-GE:B1, B3; CAN:GEOL2

A study of the earth and the physical properties which modify the earth; minerals, rocks, geologic structures and processes. ADVISORY: Eligible for English 250 and English 260.

80156 L/L SS206 Willahan D 20.0 4.0 MTWR 0900-0200

GUIDANCE

GUID 1 Self-Assessment and Career Development

Transferable: CSU; CSU-GE:E2; GAV-GE:E2

This course is designed to assist the student in learning more about personal values, personality, interests, exploration of career choice, and occupational opportunities through the use of various personal assessment instruments. The delivery options for this course also include online and self-paced formats. This course is also listed as PSYC 5. ADVISORY: Eligible for English 250 and English 260. \$12 fee will be charged for career assessment materials.

The following three distance ed classes will be delivered entirely over the internet. You must have an email account to take these courses. Start your course by going to www.gavilan.edu/disted. Unless you have made prior arrangements with the instructor, you MUST login by 11:59 pm on the first day of the class. Late adds must login within 24 hours of adding this course. If you miss the deadline you may be dropped. For help, contact your instructor or email disted@gavilan.edu.

80350 ONLINE Stewart J 3.0
This online class will be delivered entirely over the Internet. See statement above.

80020 ONLINE Tenney L 3.0
This online class will be delivered entirely over the Internet. See statement above.

80351 ONLINE Sharboneau R 3.0
05/22/09 - 06/12/09 This intensive three-week early-start online class will be delivered entirely over the Internet. See statement above. An orientation to online learning and login assistance will be available on May 22 ONLY. The orientation sessions will be held in the library from 9-11 and from 1:00-2:30.

Check out online and hybrid classes.

page 35 (Summer) pages 58-59 (Fall)

CRN Type Room Instructor Hrs. Units Days Begin-End

GUID 6 Life Skills for Higher Education

Transferable: CSU, UC; CSU-GE:E2; GAV-GE:E2

Evaluation and application of academic study methods to achieve subject matter mastery. Development of critical thinking skills, and application of reading, writing, note taking and test taking methods to improve personal strategies. Exploration of personal lifestyle and health factors, including the causes and management of stress, as it relates to academic success. Assessment of academic and career goals, selection of majors, and development of education plans. Topics covered include creative and realistic goal setting, academic and life management, college and community resources, library and Internet use, time management, and techniques to reduce math and science anxiety. This class will address a multitude of cultural learning styles, with emphasis on attaining professional, personal and academic goals in a diverse society. Topics from developmental psychology, learning theory and personality theory. ADVISORY: Eligible for English 250 and English 260.

80352 Lec HOL1 Lopez A 6.0 2.0 TWR 0930-1130
Above class meets at the Hollister Briggs site.

80036 ONLINE Marquez C 2.0
You must have an email account to take this course. Start your course by going to www.gavilan.edu/disted. Unless you have made prior arrangements with the instructor, you MUST login by 11:59 pm on the first day of the class. Late adds must login within 24 hours of adding this course. If you miss the deadline you may be dropped. For help, contact your instructor or email disted@gavilan.edu.

GUID 22 Field Work and Service

Transferable: CSU

Supervised field work within the college and with local agencies. Students serve in useful group activities in leadership roles prescribed for them by faculty or community agencies. A maximum of six units may be completed. This is a pass/no pass course. REQUIRED: Learning contracts must be filled out and signed by the student and the supervising instructor.

80359 Fld Ex LI117 Maringer J 1.0 Day/Time - see instructor
Contact the Disability Resource Center (DRC) Office.

GUID 200 Planning College Success

Transferable: No; GAV-GE:E2

Course is designed to enable students to plan a successful college experience. Content includes degree, major, graduation and transfer requirements. Skills necessary for academic success are presented and practiced. Students will learn general principles about libraries and the search for information. College support services will be identified and utilized during the course. This is a variable unit course; students will earn .5 unit of credit for every 9 hours of participation.

80261 Lec PB20 Palacios L 6.0 2.0 MTWR 1030-1145
This class is part of the Summer Bridge Program. See ad on page 32. Students must also enroll in CMUN 10, CRN 80091. Additional requirement: Students will participate in a University visit on Friday, July 17th from 9 am - 3 pm.

80354 Lec PB20 Garcia M 6.0 2.0 MTWR 0845-1000
This class is part of the Summer Bridge Program. See ad on page 32. Students must also enroll in CMUN 10, CRN 80363. Additional requirement: Students will participate in a University visit on Friday, July 17th from 9 am - 3 pm.

80355 Lec BU120 Foguet-Mendoza 6.0 2.0 TWR 1000-1200

GUID 550 Supervised Tutoring

Transferable: No

Laboratory class emphasizing college learning skills, appropriate study techniques, and learning assistance utilizing one-on-one or small group tutorial. Guid 550 is a non-credit class and will not appear on a student's transcript.

80454 Lab LI168 Computer Place
80455 Lab PH101 Math Lab
80456 Lab LI116 Tutoring Center
80457 Lab LI116 Tutoring Center
80458 Lab LI120 Writing Center

CRN Type Room Instructor Hrs. Units Days Begin-End

GUID 557 Learning Skills Assessment

Transferable: No

This course provides an assessment of the students' cognitive/perceptual abilities and basic skills academic achievement. The assessment results are used to determine the students' eligibility for Learning Disabilities Services, to develop individual educational plans, and/or to improve the students' understanding of their own learning strengths and weaknesses. The assessment is conducted on a one-to-one basis by appointment. Units earned in this course do not count toward the associate degree and/or certificate requirements. This is a pass/no pass course.

80123 Lab LI117 Burgman L .5 Day/Time - see instructor
Overson R

GUID 558 Learning Skills Laboratory

Transferable: No

The Learning Skills Laboratory is designed to assist students who are eligible to receive Learning Disabilities Services and/or have demonstrated academic deficits. The course content is individualized and based on Student Educational Contracts which are developed for each student. Students receive supplemental instruction, academic support, and learning strategy suggestions appropriate for their individual cognitive, perceptual, and academic strengths and weaknesses. Units earned do not count towards the associate degree and/or certificate requirements. This is a pass/no pass course. ADVISORY: Completion of Guidance 557 or demonstrated academic deficit.

80126 Lab LI116 Overson R .5 Day/Time - see instructor
Burgman L

HISTORY

HIST 1 United States History through Reconstruction

Transferable: CSU, UC; CSU-GE:C2, D6, IGETC:3B, 4F, 7B; GAV-GE:C2, D2; CAN:HIST8, HIST SEQ B

History of the United States from the time before European contact with the Americas through Reconstruction. Emphasis will be placed on distinctive patterns of political, economic, social, intellectual, and geographic developments within their global context. At the conclusion of the course, the student should understand major themes in the history of the United States, and be able to explain various ways in which ideas about federal vs. state power, ethnicity, class, and gender divisions have influenced the nation's development. This course has the option of a letter grade or pass/no pass. ADVISORY: Eligible for English 250 and English 260.

80187 Lec SS210 STAFF S 9.0 3.0 MTR 0600-0850

HIST 2 United States History Reconstruction to the Present

Transferable: CSU, UC; CSU-GE:C2, D6, IGETC:3B, 4F, 7B; GAV-GE:C2, D2; CAN:HIST10, HIST SEQ B

History of the United States from Reconstruction to the present. Emphasis will be placed on distinctive patterns of political, economic, social, intellectual, and geographic developments within their global context. At the conclusion of the course, the student should understand major themes in the history of the United States, and be able to explain various ways in which ideas about federal vs. state power, ethnicity, class, and gender divisions have influenced the nation's development. This course has the option of a letter grade or pass/no pass. ADVISORY: Eligible for English 250 and English 260.

80189 Lec SS210 Kier D 9.2 3.0 MTWR 0800-1005

80190 Lec PB19 Kier D 9.2 3.0 MTWR 1030-1235

JAPANESE

JPN 1A Elementary Japanese

Transferable: CSU, UC; CSU-GE:C2; GAV-GE:C2

Beginning course with emphasis on understanding and speaking Japanese; introduction to reading and writing Japanese. This course will also introduce students to Japanese culture and institutions. This course has the option of a letter grade or pass/no pass.

80413 L/L SS110 Sakai T 10.8 5.0 MTWR 0110-0335
06/15/09 - 08/07/09

Campus under construction
ROOM NUMBERS MAY CHANGE!

Check room numbers online before your first class.

Classroom Locations: Refer to "How to Use This Schedule" on page 5.

CRN Type Room Instructor Hrs. Units Days Begin-End

LIBRARY

LIB 3 Research Skills

Transferable: CSU

Research and evaluation skills using the Internet and other electronic resources, as well as traditional printed materials. Also listed as CSIS 3. This course has the option of a letter grade or pass/no pass. May be repeated once for credit. ADVISORY: Eligible for English 250 and 260.

80133 ONLINE Young D 2.0
 06/15/09 - 08/07/09 You must have an email account to take this course. Start your course by going to www.gavilan.edu/disted. Unless you have made prior arrangements with the instructor, you MUST login by 11:59 pm on the first day of the class. Late adds must login within 24 hours of adding this course. If you miss the deadline you may be dropped. For help, contact your instructor or email disted@gavilan.edu.

LIB 6 Web Page Authoring I

Transferable: CSU; GAV-GE:E2

A introduction to using Hypertext Mark-Up Language (HTML) and Extensible HTML (XHTML) to create web pages which can be uploaded and displayed on the World Wide Web. Students will use HTML/XHTML to create web pages with text in various sizes and colors, links to other sites, background color or patterns, graphics, tables, and mailto links. Principles of design and color as they apply to screen presentations will be included. This course has the option a letter grade or pass/no pass. May be repeated three times for credit. Also listed as CSIS 6 and DM 6. ADVISORY: CSIS 1 or CSIS 2 or CSIS/LIB 3 advised.

80443 Lec MHG8 Van Tassel D 8.7 2.0 MWR 0410-0655
 06/15/09 - 07/09/09 Above class meets at Morgan Hill Community site.

MATHEMATICS

MATH 5 Introduction to Statistics

Transferable: CSU, UC; CSU-GE:B4, IGETC:2A; GAV-GE:B4; CAN:STAT2

Descriptive analysis and presentation of either single-variable data or bivariate data, probability, probability distributions, normal probability distributions, sample variability, statistical inferences involving one and two populations, analysis of variance, linear correlation and regression analysis. Statistical computer software will be extensively integrated as a tool in the description and analysis of data. PREREQUISITE: Mathematics 233 with a grade of 'C' or better. The instructor will be using and supporting a TI-83 Plus graphing calculator in all classroom demonstrations.

80160 Lec LS101 Potter R 12.0 3.0 MTWR 0130-0420

80163 Lec MHG3 Viarengo A 12.0 3.0 MTWR 0600-0850
 Above class meets at Morgan Hill Community site.

MATH 8A First Half of Precalculus

Transferable: CSU, UC; CSU-GE:B4, IGETC:2A; GAV-GE:B4

Math 8A prepares the student for the study of calculus by providing important skills in algebraic manipulation, interpretation, and problem solving at the college level. Topics will include basic algebraic concepts, complex numbers, equations and inequalities of the first and second degree, functions, and graphs, linear and quadratic equations, polynomial functions, exponential and logarithmic functions, systems of equations, matrices and determinants, right triangle trigonometry, and the Law of Sines and Cosines. PREREQUISITE: Mathematics 233 with a grade of 'C' or better. The instructor will be using and supporting TI-83 Plus graphing calculator in all classroom demonstrations.

80165 Lec CH102 Lee R 12.0 4.0 MTWR 0900-1140

MATH 205 Elementary Algebra

Transferable: No; GAV-GE:B4

This course is a standard beginning algebra course, including algebraic expressions, linear equations and inequalities in one variable, graphing, equations and inequalities in two variables, integer exponents, polynomials, rational expressions and equations, radicals and rational exponents, and quadratic equations. Mathematics 205, 205A and 205B, and 206 have similar course content. This course may not be taken by students who have completed Mathematics 205B or 206 with a grade of "C" or better. This course may be taken for Mathematics 205B credit (2.5 units) by those students who have successfully completed Mathematics 205A with a grade of "C" or better. PREREQUISITE: MATH 402 with a grade of 'C' or better or assessment test recommendation.

80166 Lec PH103 Nari J 14.0 5.0 MTWR 0830-1145

80310 Lec PH103 Lockhart L 14.0 5.0 MTWR 0100-0415



New to college?
 Start out on the right foot by taking ...



GUIDE 6 Life Skills for higher education

... and learn success strategies such as study skills, goal setting and time management!

2 units

Fulfills Gavilan general education and CSU transfer requirements and is UC transferable.

Become an Expert Researcher!



Register for **LIB 3 Internet & Information Competency**

Also listed as CSIS 3



Summer Academy August 17-21, 2009

Calling all STEM (Science, Technology, Engineering and Mathematics) majors!

Are you eligible for Pre-Calculus?

Then come and join us for a week of workshops and activities which will introduce you to the sciences. Call Hope Jukl at (408) 846-4947.

CRN Type Room Instructor Hrs. Units Days Begin-End

MATH 205A First Half of Elementary Algebra

Transferable: No; GAV-GE:B4

This course is the first half of the Elementary Algebra course. It will cover signed numbers, evaluation of expressions, ratios and proportions, solving linear equations, and applications. Graphing of lines, the slope of a line, graphing linear equations, solving systems of equations, basic rules of exponents, and operations on polynomials will be covered. PREREQUISITE: Effective Fall 2005: MATH 402 with a grade of 'C' or better or assessment test recommendation. ADVISORY: Concurrent enrollment in Guidance 563A is advised.

80423 Lec HOL4 Wagman K 18.0 2.5 MTWRF 1200-0320
 06/15/09 - 07/10/09 Above class meets at the Hollister Briggs site.

MATH 205B Second Half of Elementary Algebra

Transferable: No; GAV-GE:B4

This course contains the material covered in the second half of the Elementary Algebra Course. It will cover factoring, polynomials, solving quadratic equations by factoring, rational expressions and equations, complex fractions, radicals and radical equations, solving quadratic equations by completing the square and the quadratic formula. Application problems are integrated throughout the topics. PREREQUISITE: Math 205A with a grade of 'C' or better. ADVISORY: Concurrent enrollment in Guidance 563B is advised.

80424 Lec HOL4 Wagman K 18.0 2.5 MTWRF 1200-0320
 07/13/09 - 08/07/09 Above class meets at the Hollister Briggs site.

CRN Type Room Instructor Hrs. Units Days Begin-End

MATH 208 Plane Geometry

Transferable: No

This course introduces the vocabulary and principles of Euclidean Geometry. Methods of proof including inductive and deductive reasoning will be developed. Concepts of congruence and similarity, angles, lines, polygons, and circles will be covered. Additional topics such as solid geometry, analytical geometry, transformations, and basic trigonometry may be included as time allows. PREREQUISITE: Math 205 or Math 205A and Math 205B with a grade of 'C' or better.

80173 Lec PB19 Maisch F 9.2 3.0 MTWR 0800-1005

MATH 233 Intermediate Algebra

Transferable: No; GAV-GE:B4

Review of basic concepts, linear equations and inequalities, graphs and functions, systems of linear equations, polynomials and polynomial functions, factoring, rational expressions and equations, roots, radicals, and complex numbers, solving quadratic equations, exponential and logarithmic functions, and problem solving strategies. Mathematics 233, 233A, and 233B have similar course content. This course may not be taken by students who have completed Mathematics 233B with a grade of 'C' or better. This course may be taken for Mathematics 233B credit (2.5) units by those students who have successfully completed Mathematics 233A with a grade of 'C' or better. PREREQUISITE: Mathematics 205 or Mathematics 205A and 205B or Mathematics 206 with a grade of 'C' or better. The instructor will be using and supporting TI-83 Plus graphing calculator in all classroom demonstrations.

80177 Lec MHG13 Butterworth Y 14.0 5.0 MTWR 0830-1145
Above class meets at Morgan Hill Community site.

80283 Lec CH102 Lee R 14.0 5.0 MTWR 0100-0415

MATH 233A First Half of Intermediate Algebra

Transferable: No

The course will start with a review of basic concepts and then cover the following topics with an emphasis on applications and problem solving strategies: solving linear equations; solving linear, compound, and absolute value inequalities; equations and graphs of lines; functions and function notation including composition of functions; solving systems of linear equations and inequalities; an introduction to matrices and Cramer's rule; operations with polynomials; factoring polynomials; and solving polynomial equations. PREREQUISITE: Completion of Mathematics 205 or the equivalent with a grade of 'C' or better.

80425 Lec HOL4 Wagman K 18.0 2.5 MTWRF 0800-1120
06/15/09 - 07/11/09 Above class meets at the Hollister Briggs site.

MATH 233B Second Half of Intermediate Algebra

Transferable: No

This course will start with a review factoring polynomials, and then cover the following topics with an emphasis on applications and problem solving strategies: solving polynomial equations by factoring; adding, subtracting, multiplying, dividing and simplifying rational expressions and solving rational equations; adding, subtracting, multiplying, dividing and simplifying roots, radicals and complex numbers and solving radical equations; the various methods of solving quadratic equations and inequalities; graphing quadratic functions; and working with exponential and logarithmic functions, equations and expressions. PREREQUISITE: Completion of MATH 233A with a grade of 'C' or better.

80426 Lec HOL4 Wagman K 18.0 2.5 MTWRF 0800-1120
07/13/09 - 08/08/09 Above class meets at the Hollister Briggs site.

MATH 402 Pre-Algebra

Transferable: No

This course covers operations with integers, fractions and decimals and associated applications, percentages, ratio, and geometry and measurement, critical thinking and applications. Elementary algebra topics such as variables, expressions, and solving equations are introduced. PREREQUISITE: Completion of Math 400 with a 'C' or better, or assessment test recommendation.

80178 L/L LS103 Kercheval S 12.0 3.0 MTWR 0800-1050

Don't forget

A counselor's signature is required if you take 17 or more units (spring or fall) or 5 or more units (summer).

You do not need a counselor's signature to register for a class with a prerequisite that was successfully completed at Gavilan.

CRN Type Room Instructor Hrs. Units Days Begin-End

MATH 414 Basic Math Skills

Transferable: No

A remedial mathematics course designed for those students who need to learn, or re-learn, the basic concepts of math. The primary emphasis is on whole numbers, fractions, decimals, percents, and measurements. This course may be repeated three times for credit. This is a pass/no pass course. Units earned in this course do not count toward the associate degree and/or certain certificate requirements.

80427 Lab PH103 Dachkova E 23.5 1.0 MTWRF 0815-1240

08/10/09 - 08/21/09 Whether you are a student who needs more practice in understanding foundational elements of math such as fractions, percents, signed numbers and/or word problems or you just need a brush up on the basics, Math 414 is for you. This course is a two week, five hour a day, math boot camp, where students will develop or redevelop a solid understanding of basic math concepts. See ad on page 49.

PHILOSOPHY

PHIL 1 Introduction to Philosophy

Transferable: CSU, UC; CSU-GE:C2, IGETC:3B; GAV-GE:C2; CAN:PHIL2

Philosophy 1 is intended as a survey of the major areas and traditions of philosophy. The course examines central and significant questions about the meaning of life, who determines what is morally right or wrong, the ideal society, the various notions social justice, what is reality, and many other ideas. In pursuing these questions, students will be asked to read texts from writers around the world, both contemporary and ancient, discuss current events, and apply 'theory' to movies such as "The Matrix" trilogy, novels, and any other relevant application of the student's own choice. ADVISORY: Eligible for English 1A.

80102 Lec CJ500 Johnston M 9.2 3.0 MTWR 1245-0250

PHYSICAL EDUCATION - ACTIVITIES

PE 16 Swimming

Transferable: CSU, UC; CSU-GE:E1; GAV-GE:E1

Coeducational activity designed for all skill levels. The course teaches the techniques of a variety of strokes and includes conditioning activities. Instruction is tailored to meet individual and group needs. May be repeated three times for credit. This course has the option of a letter grade or pass/no pass.

80002 Lab GY100P Lango J 8.0 1.0 MTWR 1115-0115

PE 17 Golf

Transferable: CSU, UC; CSU-GE:E1; GAV-GE:E1

Coeducational activity designed for all skill levels. Fundamentals, techniques, rules and the etiquette of golf will be covered. May be repeated three times for credit. This course has the option of a letter grade or pass/no pass.

80284 Lab ERGOLF Krause S 3.4 .5 S 0900-1210
Class meets at Eagle Ridge Golf Club. Students will pay approximately \$20 in ball/equipment rental.

PE 21 Volleyball

Transferable: CSU, UC; CSU-GE:E1; GAV-GE:E1

Coeducational activity designed for beginning and intermediate volleyball students; rules, strategy and fundamentals of volleyball. May be repeated three times for credit. This course has the option of a letter grade or pass/no pass.

80094 Lab GY131G Kramer K 11.2 .5 MTWR 0900-1130
07/20/09 - 08/14/09

PE 24 Individualized Weight Training

Transferable: CSU, UC; CSU-GE:E1; GAV-GE:E1

An open laboratory for those who desire an individualized strength program using exercise machines and free weights. May be repeated three times for credit. This course has the option of a letter grade or pass/no pass.

80098 Lab GY123 Dodd S .5 Day/Time - see instructor
Students should check in the first three days of summer session at the Fitness Center (GY123) during lab hours (Mon-Fri: 7am-1pm).

80105 Lab GY123 Dodd S 1.0 Day/Time - see instructor
Students should check in the first three days of summer session at the Fitness Center (GY 123) during lab hours (Mon-Fri, 7am - 1pm).

Classroom Locations: Refer to "How to Use This Schedule" on page 5.

CRN Type Room Instructor Hrs. Units Days Begin-End

PE 25 Soccer

Transferable: CSU, UC; CSU-GE:E1; GAV-GE:E1

Co-educational activity designed for all skill levels. Fundamentals, strategy and rules of the game are included. May be repeated three times for credit. This course has the option of a letter grade or pass/no pass.

80115 Lab SOCCER Marques A 12.0 .5 MTWR 0300-0600
08/03/09 - 08/14/09

PE 27 Basketball

Transferable: CSU, UC; CSU-GE:E1; GAV-GE:E1

Co-educational activity designed for all skill levels. Fundamentals, strategy and rules of the game are included. May be repeated three times for credit. This course has the option of a letter grade or pass/no pass.

80282 Lab GY131G Addison T 4.0 .5 TR 0330-0530

PE 37 Softball

Transferable: CSU, UC; CSU-GE:E1; GAV-GE:E1

Coeducational activity designed for all skill levels. Rules, fundamentals, and strategy and game play will be included. May be repeated three times for credit. This course has the option of a letter grade or pass/no pass.

80117 Lab GY131G Dequin N 8.4 1.0 MTR 0130-0400

PE 46 Agility and Motor Development

Transferable: CSU, UC; CSU-GE:E1; GAV-GE:E1

An activity class designed to improve and increase agility and motor development through various exercise and exercise programs. May be repeated three times for credit. This course has the option of a letter grade or pass/no pass.

80154 Lab GY131G Lango J 8.0 1.0 MTWR 0300-0500

PE 61 Swim for Fitness

Transferable: CSU, UC; CSU-GE:E1; GAV-GE:E1

Designed to develop endurance and swimming skills in order to maintain good cardiovascular/physical fitness. Intermediate swimming ability recommended. May be repeated three times for credit. This course has the option of a letter grade or pass/no pass.

80155 Lab GY100P Dodd S 4.0 .5 TR 0530-0730

PE 62 Yoga

Transferable: CSU, UC; CSU-GE:E1; GAV-GE:E1

Coeducational activity designed for beginning and intermediate yoga students. A program designed to improve flexibility and reduce stress by learning a series of poses and focusing on proper breathing techniques. May be repeated three times for credit. This course has the option of a letter grade or pass/no pass.

80159 Lab APE101 Muscari D 4.0 .5 TR 0100-0300

80164 Lab APE101 Watson M 4.0 .5 TR 0530-0730

PE 64 Individualized Cardiovascular Fitness

Transferable: CSU, UC; CSU-GE:E1; GAV-GE:E1

A fitness program which develops cardiovascular endurance through an individualized open lab format. May be repeated three times for credit. This course has the option of a letter grade or pass/no pass.

80171 Lab GY123 Dodd S .5 Day/Time - see instructor
Students should check in the first three days of summer session at the Fitness Center (GY123) during lab hours (Mon - Fri, 7 am - 1 pm).

80181 Lab GY123 Dodd S 1.0 Day/Time - see instructor
Students should check in the first three days of summer session at the Fitness Center (GY123) during lab hours (Mon - Fri, 7 am - 1 pm).

PE 65 Baseball

Transferable: CSU, UC; CSU-GE:E1; GAV-GE:E1

This course is designed for students of all skill levels who desire to learn the fundamentals, mechanics, strategy and rules of the game of baseball. May be repeated three times for credit. This course has the option of a letter grade or pass/no pass.

80194 Lab GY131G Andrade N 8.4 1.0 MWR 0130-0400

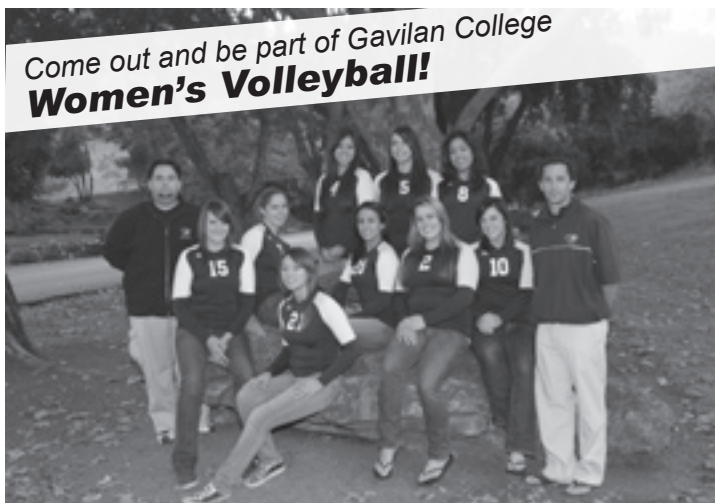

Be a part of the winning tradition... GO RAMS!

PE 24 Individualized Weight Training

PE 64 Cardiovascular Fitness

Summer Session Fitness Center Lab Hours
MTWThF 7:00 am - 1:00 pm

- Section hours by arrangement
- ✦ 1.5 to 3 weekly hours
- ✦ .5 or 1.0 unit
- ✦ Fitness Center (GYM 123)



Open Lab Class Format
Designed for individualized strength or cardiovascular fitness programs in an open lab setting using a variety of exercise equipment.

Students should check in during the first three days of the summer session during lab hours.

MATH BOOT CAMP!

MATH 414 Basic Math Skills - CRN 80427

08/10/09 - 08/21/09, meets Mon-Fri from 8:15 am - 12:40 pm

Whether you are a student who needs more practice in understanding foundational elements of math such as fractions, percents, signed numbers and/or word problems or you just need a brush up on the basics, Math 414 is for you. This course is a two week, five hour a day, math boot camp, where students will develop or redevelop a solid understanding of basic math concepts.



1 Unit

MATH 414 Basic Math Skills

A remedial mathematics course designed for those students who need to learn, or re-learn, the basic concepts of math. The primary emphasis is on whole numbers, fractions, decimals, percents, and measurements. This course may be repeated three times for credit. This is a pass/no pass course. Units earned in this course do not count toward the associate degree and/or certain certificate requirements.

CRN Type Room Instructor Hrs. Units Days Begin-End

PE 70 Pilates

Transferable: CSU, UC; CSU-GE:E1; GAV-GE:E1

This class utilizes the Pilates exercise system focused on improving flexibility and strength for the total body through a series of controlled movements. May be repeated three times for credit. This course has the option of a letter grade or pass/no pass.

80198 Lab APE101 Muscari D 4.0 .5 MW 0100-0300

PE 75 Sports Conditioning

Transferable: CSU, UC; CSU-GE:E1; GAV-GE:E1

This activity class is designed to improve the physical condition of male and female athletes. It includes strength training, cardiovascular endurance, plyometric training, and sport specific techniques. May be repeated three times for credit. This course has the option of a letter grade or pass/no pass.

80203 Lab GY123 Dodd S .5
Students should check in the first three days of summer session at the Fitness Center (GY123) during lab hours (Mon - Fri, 7 am - 1 pm).

80206 Lab GY123 Dodd S 1.0
Students should check in the first three days of summer session at the Fitness Center (GY123) during lab hours (Mon - Fri, 7 am - 1 pm).

PHYSICAL EDUCATION - ADAPTED

PE 34 Adapted Aquatic Exercise

Transferable: CSU, UC; CSU-GE:E1; GAV-GE:E1

This course is designed to help individuals who by the nature of their disability such as wheelchair use, back injury, cardiovascular impairment, multiple sclerosis or other disabling condition require a specific aquatic exercise program that will contribute to their physical well-being. May be repeated as necessary based on measurable progress as documented in the student's educational contract. This course has the option of a letter grade or pass/no pass.

80041 Lab GY100P Ellis D 3.0 .5 MTWR 0815-0900
Maringer J
Sato K
06/01/09 - 07/24/09

80042 Lab GY100P Ellis D 3.0 .5 MTWR 1045-1130
Maringer J
Sato K
06/01/09 - 07/24/09

80045 Lab GY100P Ellis D 3.0 .5 MTWR 1145-1230
Maringer J
Sato K
06/01/09 - 07/24/09

PE 35 Adapted Swimming for Total Fitness

Transferable: CSU, UC; CSU-GE:E1; GAV-GE:E1

An individualized program of activities designed for students with physical disabilities to improve flexibility and range-of-motion, increase joint movement, improve circulation, and improve control of body movement through water adjustment and activities. Develops an appreciation of physical activity as a regular planned contribution to one's overall well-being. May be repeated as necessary based on measurable progress as documented in the student's educational contract. This course has the option of a letter grade or pass/no pass.

80048 Lab GY100P Ellis D 3.0 .5 MTWR 0815-0900
Maringer J
Sato K
06/01/09 - 07/24/09

80053 Lab GY100P Ellis D 3.0 .5 MTWR 1045-1130
Maringer J
Sato K
06/01/09 - 07/24/09

80054 Lab GY100P Ellis D 3.0 .5 MTWR 1145-1230
Sato K
Maringer J
06/01/09 - 07/24/09



Appropriate footwear is required in all gym facilities. No barefeet permitted.

CRN Type Room Instructor Hrs. Units Days Begin-End

PE 36 Adapted Physical Education

Transferable: CSU, UC; CSU-GE:E1; GAV-GE:E1

An individualized program of adaptive physical education activities designed to meet the needs of students with physical disabilities. Develops an appreciation of physical activity as a regular planned contribution to one's overall well-being. May be repeated as necessary based on measurable progress as documented in the student's educational contract. This course has the option of a letter grade or pass/no pass.

80056 Lab APE 101/108 Ellis D 3.0 .5 MTWR 0945-1030
Sato K
Maringer J

PE 38 Adapted Cardiovascular Conditioning & Training

Transferable: CSU, UC; CSU-GE:E1; GAV-GE:E1

An individualized program of adapted exercises in weight training, stretching and cardiovascular conditioning for those individuals that have been disabled through stroke, cardiovascular accident, arthritis, multiple sclerosis, or other condition. May be repeated as necessary based on measurable progress as documented in the student's educational contract. This course has the option of a letter grade or pass/no pass.

80058 Lab APE101/108 Ellis D 3.0 .5 MTWR 0945-1030
Maringer J
Sato K

PE 534 Adapted Aquatic Exercise

Transferable: No

Designed to help individuals who by the nature of their disability such as wheelchair use, back injury, cardiovascular impairment, multiple sclerosis or other disabling condition require a specific aquatic exercise program that will contribute to their physical well being. May be repeated as necessary based on measurable progress as documented in the student's educational contract. This is a pass/no pass course.

80062 Lab GY100P Ellis D 3.0 .5 MTWR 0815-0900
Maringer J
Sato K
06/01/09 - 07/24/09

80064 Lab GY100P Ellis D 3.0 .5 MTWR 1045-1130
Sato K
Maringer J
06/01/09 - 07/24/09

80066 Lab GY100P Ellis D 3.0 .5 MTWR 1145-1230
Sato K
Maringer J
06/01/09 - 07/24/09

PE 535 Adapted Swimming for Total Fitness

Transferable: No

An individualized program of activities designed for students with physical disabilities to improve flexibility and range-of-motion, increase joint movement, improve circulation, and improve control of body movement through water adjustment and activities. Develops an appreciation of physical activity as a regular planned contribution to one's overall well-being. May be repeated as necessary based on measurable progress as documented in the student's educational contract. This course is pass/no pass.

80080 Lab GY100P Ellis D 3.0 .5 MTWR 0815-0900
Sato K
Maringer J
06/01/09 - 07/24/09

80081 Lab GY100P Ellis D 3.0 .5 MTWR 1045-1130
Maringer J
Sato K
06/01/09 - 07/24/09

80082 Lab GY100P Ellis D 3.0 .5 MTWR 1145-1230
Sato K
Maringer J
06/01/09 - 07/24/09

CRN Type Room Instructor Hrs. Units Days Begin-End

PE 536 Adapted Physical Education

Transferable: No

An individualized program of adaptive physical education activities designed to meet the needs of students with physical disabilities. Develops an appreciation of physical activity as a regular planned contribution to one's overall well-being. May be repeated as necessary based on measurable progress as documented in the student's educational contract. This is a pass/no pass course.

80083 Lab APE101/108 Ellis D 3.0 .5 MTWR 0945-1030
Maringer J
Sato K

06/01/09 - 07/24/09

80093 Lab LOADCS1 Sato K 3.0 .5 MTWR 0945-1030
Maringer J

06/01/09 - 07/24/09 Above class meets at Live Oak Adult Day Services, 651 West Sixth St., Gilroy.

80135 Lab APE101/108 Ellis D 3.3 .5 F 0945-1250
06/01/09 - 07/24/09 Specialized class for students with developmental disabilities.

PE 538 Adapted Cardiovascular Conditioning & Training

Transferable: No

An individualized program of adapted exercises in weight training, stretching and cardiovascular conditioning for those individuals that have been disabled through stroke, cardiovascular accident, arthritis, multiple sclerosis, or other condition. May be repeated as necessary based on measurable progress as documented in the student's educational contract. This is a pass/no pass course.

80101 Lab APE101/108 Ellis D 3.0 .5 MTWR 0945-1030
Sato K
Maringer J

POLITICAL SCIENCE

POLS 1 Introduction to American Government

Transferable: CSU, UC; CSU-GE:D8, IGETC:4H, 7A; GAV-GE:D1, D2; CAN:GOVT2

Explores the development of American political institutions and their utilization in dealing with issues arising at the international, national and state levels. Emphasis is placed on those problems which have defined our federal system of government. California government and appropriate state institutions will be included as a vital part of our federal system of government. ADVISORY: Eligible for English 250 and English 260.

80191 Lec PB19 Kier D 9.2 3.0 MTWR 0230-0435

The following three online classes will be delivered entirely over the Internet. You must have an email account to take this course. Start your course by going to www.gavilan.edu/disted. Unless you have made prior arrangements with the instructor, you MUST login by 11:59 pm on the first day of the class. Late adds must login within 24 hours of adding this course. If you miss the deadline you may be dropped. For help, contact your instructor or email disted@gavilan.edu.

80193 ONLINE Turetzky M 3.0
This online class will be delivered entirely over the Internet. See statement above.

80195 ONLINE Turetzky M 3.0
This online class will be delivered entirely over the Internet. See statement above.

80196 ONLINE Turetzky M 3.0
This online class will be delivered entirely over the Internet. See statement above.

PSYCHOLOGY

PSYC 1A Introduction to Psychology

Transferable: CSU, UC; CSU-GE:D9, IGETC:4I; GAV-GE:D2; CAN:PSY2

The nature, scope, methods, presuppositions, history, and fields of psychology together with the scientific study of factors influencing human behavior, human development, perception, learning, memory, emotion, personality, frustration, and psychotherapy. ADVISORY: Eligible for English 250 and English 260.

80197 Lec MHG4 Campilli J 9.2 3.0 MTWR 1030-1235
Above class meets at Morgan Hill Community site.

80199 Lec SS214 Campilli J 9.0 3.0 MWR 0600-0850



Classes are short-term, not-for-credit, offered during evenings & weekends, affordable and are designed just for you!

TAKE A LOOK AT SOME OF OUR MOST POPULAR CLASSES:

Interior Design Series

3/3-3/24
Tuesday, 6:30 - 8:30 pm
Room: CJ500; \$99

Small Business Success Series

3/2-3/23
Monday, 6:00 - 9:00 pm
Room: L1171; \$199

Spring Spa: Do it Yourself Series (Ages 16 & Up)

2/21, 3/21, 4/18 & 5/16
Saturday, 9:00 am - 12:00 pm
Room: PB8; \$159 + \$70 materials fee to instructor

Microsoft Office 2003, Intermediate

Excel, Word & PowerPoint
2/21-3/7
Saturday, 9:00 am - 3:00 pm
Room: BU111; \$249 + \$60 materials fee to instructor

Writing, Publishing & Marketing Your First Book Conference

3/14
Saturday, 1:00 - 7:30 pm
Room: L1100; \$87 + \$15 materials fee to instructor

HR Management

2/19-3/12
Thursday, 6:00 - 8:00 pm
Room: L1100; \$175 + \$20 materials fee to instructor

Other Popular Classes:

- Pharmacy Technician
- Salsa, Belly & Ballroom Dancing
- Voice Acting
- Mystery Shopper

HOW CAN I REGISTER FOR THESE CLASSES?

Online to <http://gavilan.augusoft.net>
Call 408-852-2801
Fax your registration to 408-852-2805
In person
or mail to Gavilan College, Community Education, 5055 Santa Teresa Blvd., Gilroy, Ca. 95020

CRN Type Room Instructor Hrs. Units Days Begin-End

PSYC 2 Early Child Development

Transferable: CSU, UC; CSU-GE:D9, E, IGETC:4I; GAV-GE:D2

A systematic study of the child from prenatal life through the preschool years. The course integrates the basic concepts of physical, cognitive and psychosocial development at each major stage of life during this period. This course is also listed as CD 2. This course has the option of a letter grade or pass/no pass. ADVISORY: Eligible for English 250 and English 260.

The following two distance ed classes will be delivered entirely over the internet. You must have an email account to take these courses. Start your course by going to www.gavilan.edu/disted. Unless you have made prior arrangements with the instructor, you MUST login by 11:59 pm on the first day of the class. Late adds must login within 24 hours of adding this course. If you miss the deadline you may be dropped. For help, contact your instructor or email disted@gavilan.edu.

80381	ONLINE	TBA		3.0			
This online class will be delivered entirely over the Internet. See statement above.							
80431	ONLINE	Brown R		3.0			
This online class will be delivered entirely over the Internet. See statement above.							

PSYC 3 Child Growth and Development During the School Years

Transferable: CSU, UC; CSU-GE:D9, E, IGETC:4I; GAV-GE:D2

Continuation of the study of child development with emphasis on children from six years of age through adolescence. Includes developmental theories and topics relevant to these ages. This course is also listed as CD 3. This course has the option of a letter grade or pass/no pass. ADVISORY: Eligible for English 250 and English 260; Psychology 2.

The following two distance ed classes will be delivered entirely over the internet. You must have an email account to take these courses. Start your course by going to www.gavilan.edu/disted. Unless you have made prior arrangements with the instructor, you MUST login by 11:59 pm on the first day of the class. Late adds must login within 24 hours of adding this course. If you miss the deadline you may be dropped. For help, contact your instructor or email disted@gavilan.edu.

80228	ONLINE	Bumgarner M		3.0			
This online class will be delivered entirely over the Internet. See statement above.							
80432	ONLINE	Hoshiko M		3.0			
This online class will be delivered entirely over the Internet. See statement above.							

PSYC 5 Self-Assessment and Career Development

Transferable: CSU; CSU-GE:E2; GAV-GE:E2

A course designed to assist the student in learning more about personal values, personality, interests, exploration of career choice, and occupational opportunities through the use of various personal assessment instruments. The delivery options for this course include online and self-paced formats. This course is also listed as GUID 1. ADVISORY: Eligible for English 250 and English 260. \$12 fee will be charged for career assessment materials.

The following three distance ed classes will be delivered entirely over the internet. You must have an email account to take these courses. Start your course by going to www.gavilan.edu/disted. Unless you have made prior arrangements with the instructor, you MUST login by 11:59 pm on the first day of the class. Late adds must login within 24 hours of adding this course. If you miss the deadline you may be dropped. For help, contact your instructor or email disted@gavilan.edu.

80010	ONLINE	Stewart J		3.0			
This online class will be delivered entirely over the Internet. See statement above.							
80029	ONLINE	Tenney L		3.0			
This online class will be delivered entirely over the Internet. See statement above.							
80353	ONLINE	Sharboneau R		3.0			
05/22/09 - 06/12/09 This intensive three-week early-start online class will be delivered entirely over the Internet. See statement above. An orientation to online learning and login assistance will be available on May 22 ONLY. The orientation sessions will be held in the library (LI 168) from 9-11 and from 1:00-2:30.							

REAL ESTATE

RE 160 Real Estate Principles

Transferable: CSU

The fundamental course covering an introduction to the field of real estate. Provides understanding, background and terminology necessary for advanced specialized courses. Will meet requirements for the Real Estate Sales License. This course has the option of a letter grade or pass/no pass. ADVISORY: Eligible for English 250, English 260 and Mathematics 205.

80391	Lec	MHG12	Frimann G	4.0	3.0	S	0830-1230
06/06/09 - 08/22/09 Above class meets at Morgan Hill Community site.							

CRN Type Room Instructor Hrs. Units Days Begin-End

RE 166 Property Management

Transferable: CSU

A study of techniques and practices in the management of income property from acquisition to disposal. The course will cover neighborhood analysis, rent schedules, rental finance, collections, eviction, maintenance and rehabilitation, tax considerations, depreciation and the pitfalls in the purchase of income property. This course may be used for the California Broker's License. This course has the option of a letter grade or pass/no pass. May be repeated three times for credit. ADVISORY: Real Estate 160

80392	Lec	LS106	Banks S	6.6	3.0	MW	0600-0905
06/15/09 - 08/05/09							

SOCIOLOGY

SOC 1A Introduction to Sociology

Transferable: CSU, UC; CSU-GE:D0, IGETC:4J; GAV-GE:D2; CAN:SOC2

Analysis of the structure and dynamics of human society focusing on the development of culture, the socialization process, group behavior, social inequality, deviance, sexism, racism, and ageism, major social institutions, and human ecology. Emphasizes contemporary American society. ADVISORY: Eligible for English 250 and English 260.

The following two distance ed classes will be delivered entirely over the internet. You must have an email account to take these courses. Start your course by going to www.gavilan.edu/disted. Unless you have made prior arrangements with the instructor, you MUST login by 11:59 pm on the first day of the class. Late adds must login within 24 hours of adding this course. If you miss the deadline you may be dropped. For help, contact your instructor or email disted@gavilan.edu.

80201	ONLINE	Kreider R		3.0			
This online class will be delivered entirely over the Internet. After enrolling, start the class by going to http://www.gavilan.edu/disted , and log into the system. Students who have not logged in by 5 pm on the 3rd day may be dropped from the class.							
80428	ONLINE	Kreider R		3.0			
This online class will be delivered entirely over the Internet. After enrolling, start the class by going to http://www.gavilan.edu/disted , and log into the system. Students who have not logged in by 5 pm on the 3rd day may be dropped from the class.							

SOC 3 Sociology of Race, Ethnicity and Cultural Identity

Transferable: CSU, UC; CSU-GE:D0, IGETC:4J; GAV-GE:D2, F

This course is designed to introduce students to the basic sociological concepts and theories of race, ethnicity and cultural identity in U.S. society. Students will examine race, ethnicity and cultural identity as social constructs that permeate social structures and institutions, and how they change over time and space. Over the semester students will critically analyze the ways which race, ethnicity, class, and gender/sexuality continually shape peoples lives and experiences. While the class focuses on U.S. societies, students will also critically compare and contrast race and ethnicity in other societies. ADVISORY: Eligible for English 250 and English 260.

80202	Lec	HOL2	Cervantes E	9.0	3.0	TWR	0600-0850
Above class meets at the Hollister Briggs site.							

SPANISH

SPAN 1A Elementary Spanish

Transferable: CSU, UC; CSU-GE:C2; GAV-GE:C2; CAN:SPAN2, SPAN SEQ A

Beginning course with emphasis on understanding and speaking Spanish; introduction to reading and writing Spanish. This course will also introduce students to Hispanic culture and institutions. This course has the option of a letter grade or pass/no pass.

80213	L/L	SPAIN	Marques A		5.0		
06/01/09 - 06/26/09 Above class meets off-campus: Travel Study in Seville, Spain.							
80215	L/L	CJ500	Perez D	25.0	5.0	MTWRF	0800-1240

SPAN 1B Elementary Spanish

Transferable: CSU, UC; CSU-GE:C2, IGETC:6A; GAV-GE:C2; CAN:SPAN4, SPAN SEQ A

Continuation of Spanish 1A. Further development of the four skills of understanding, speaking, reading and writing Spanish. This course will continue to emphasize the study of Hispanic culture and institutions. This course has the option of a letter grade or pass/no pass. ADVISORY: Spanish 1A or equivalent.

80217	L/L	SPAIN	Marques A		5.0		
06/01/09 - 06/26/09 Above class meets off-campus: Travel Study in Seville, Spain.							

CRN Type Room Instructor Hrs. Units Days Begin-End

SPAN 2A Intermediate Spanish

Transferable: CSU, UC; CSU-GE:C2, IGETC:3B, 6A; GAV-GE:C2; CAN:SPAN8, SPAN SEQ B
 Review of basic structures through conversation and selected works of literature. Further expansion of patterns, vocabulary and idioms. Creative expression through discussion and composition. This course has the option of a letter grade or pass/no pass. ADVISORY: Spanish 1B or equivalent.

80219 L/L SPAIN Marques A 5.0
 Above class meets off-campus: Travel Study in Seville, Spain.

SPAN 2B Intermediate Spanish

Transferable: CSU, UC; CSU-GE:C2, IGETC:3B, 6A; GAV-GE:C2; CAN:SPAN10, SPAN SEQ B
 Review of basic structures and grammar with greater emphasis on vocabulary and idioms. Introduction to literature as it reflects the characteristics of Hispanic societies. Greater emphasis on composition as a medium of expression. This course has the option of a letter grade or pass/no pass. ADVISORY: Spanish 2A or equivalent.

80220 L/L SPAIN Marques A 5.0
 Above class meets off-campus: Travel Study in Seville, Spain.

SPAN 8A Conversational Spanish

Transferable: CSU; GAV-GE:C2

This course is a beginning Spanish course, focusing on the Spanish sound system, basic grammar and vocabulary, and cultural elements. Although emphasis is on listening and speaking, basic reading and writing skills will be developed. This course has the option of a letter grade or pass/no pass.

80222 Lec SPAIN Marques A 3.0
 Above class meets off-campus: Travel Study in Seville, Spain.

SPAN 8B Conversational Spanish

Transferable: CSU; GAV-GE:C2

This course requires knowledge of Spanish pronunciation, basic vocabulary, and present tense grammar. More advanced grammar and vocabulary, and cultural elements will be taught in the development of listening, speaking, basic reading and writing skills. This course has the option of a letter grade or pass/no pass. ADVISORY: Spanish 8A or equivalent.

80224 Lec SPAIN Marques A 3.0
 Above class meets off-campus: Travel Study in Seville, Spain.

SPAN 8C Conversational Spanish

Transferable: CSU; GAV-GE:C2

This course requires considerable knowledge of Spanish pronunciation, vocabulary, grammar and syntax. More advanced grammar and vocabulary will be taught in the development of listening, speaking, reading and writing skills. ADVISORY: Spanish 8B or equivalent.

80227 Lec SPAIN Marques A 3.0
 Above class meets off-campus: Travel Study in Seville, Spain.

SPAN 8D Conversational Spanish

Transferable: CSU; GAV-GE:C2

This course requires fluency in spoken and written Spanish. Advanced grammar and vocabulary will be presented while the course concentrates on polishing the student's oral and written skills and develops a sense of style. ADVISORY: Spanish 8C or equivalent.

80229 Lec SPAIN Marques A 3.0
 Above class meets off-campus: Travel Study in Seville, Spain.

SPAN 12A Spanish for Spanish Speakers

Transferable: CSU, UC; CSU-GE:C2, IGETC:6A; GAV-GE:C2, F

Through comparative analysis of selected literary works, the course develops an awareness of cultural and literary contributions from Mexico and other Spanish speaking societies. The course is taught in Spanish with emphasis on composition as a medium of expression. This course has the option of a letter grade or pass/no pass. ADVISORY: Basic Spanish reading and writing skills.

80289 ONLINE Perez D 5.0
 You must have an email account to take this course. Start your course by going to www.gavilan.edu/disted. Unless you have made prior arrangements with the instructor, you MUST login by 11:59 pm on the first day of the class. Late adds must login within 24 hours of adding this course. If you miss the deadline you may be dropped. For help, contact your instructor or email disted@gavilan.edu.



Study and travel this summer!



Learn Spanish in Spain!



Study the language and culture while living with a host family in Seville, Spain

June 1-26
 Earn up to 5 units

Cost: Approximately \$1,500 plus airfare for a 4-week program.

For more information, visit the website at www.gavilan.edu/spanish or call Albert Marques at (408) 848-4794 or email amarques@gavilan.edu

CRN Type Room Instructor Hrs. Units Days Begin-End

SPAN 98 Special Topics

Transferable: CSU

Special topics courses examine current problems or issues of interest to students within a specific discipline area. For topical content information, consult with the appropriate department chairperson. For transfer status, check with a counselor. May be repeated for credit with different topics. This course may have the option of a letter grade or pass/no pass.

80234 Ind SPAIN Marques A 3.0
 Above class meets off-campus: Travel Study in Seville, Spain.

THEATRE ARTS / TV / DRAMA

THEA 23 Independent Study

Transferable: CSU

Designed to afford selected students specialized opportunities for exploring areas at the independent study level. The courses may involve extensive library work, research in the community, or special projects. May be repeated until six units of credit are accrued. This course has the option of a letter grade or pass/no pass. REQUIRED: The study outline prepared by the student and the instructor must be filed with the department and the dean.

80111 Ind PB15 Abad M 1.0
 80130 Ind PB15 Abad M 2.0

VOCATIONAL PREP STUDENTS: DISABILITY

AE 600 Vocational Training I

Transferable: No

Prevocational skills for adults with impaired cognitive functioning. Entry level work preparation is emphasized. Skills taught include basic work routine orientation, communication skills, job ability assessment, and self-management skills.

80007 Lab Merrill T
 06/01/09 - 08/31/09 Above class meets at HOPE Workshop 8855 Murray Avenue, Gilroy. Open Entry - Open Exit.
 80014 Lab Brown C/Sato K
 06/01/09 - 08/31/09 Above class meets at HOPE Workshop, 2300 Technology Parkway, Hollister. Open Entry - Open Exit.

CRN Type Room Instructor Hrs. Units Days Begin-End

AE 602 Vocational Training III

Transferable: No

Practical training and on-the-job work experience for students with disabilities. This course also provides preparation for entry level employment utilizing a number of work alternatives and settings.

80016	Lab		Merrill T				
06/01/09 - 08/31/09 Above class meets at HOPE Workshop, 8855 Murray Avenue, Gilroy. Open Entry - Open Exit.							
80019	Lab		Brown C/Sato K				
06/01/09 - 08/31/09 Above class meets at HOPE Workshop, 2300 Technology Parkway, Hollister. Open Entry - Open Exit.							
80023	Lab	LI204	Franklin L				
06/01/09 - 07/24/09							

AE 636 Adapted Physical Education

Transferable: No

An individualized program of adapted physical education activities designed to meet the needs of students who have physical limitations or disabilities. The course assists in the development and appreciation of physical activity as a regular planned contribution to one's overall well-being. This course is for the non-matriculating student, is not graded and is without college credit. ADVISORY: Students must be able to document a physical disability.

80358	Lab	APE108	Ellis D	3.3	F	0945-1250	
06/01/09 - 07/24/09 Specialized class for students with developmental disabilities.							
80039	Lab	GY100P	Ellis D/Sato K/Maringer J				
06/01/09 - 07/24/09							
80357	Lab	LOADCS1	Sato K Maringer J	3.0	MTWR	0945-1030	
06/01/09 - 07/24/09 Above class meets at Live Oak Adult Day Services, 651 West Sixth St., Gilroy.							

WORK EXPERIENCE

CWE 192 General Work Experience Education

Transferable: CSU

General work experience for students who have a job unrelated to their major. General work experience is supervised employment which is intended to assist students in acquiring desirable work habits, attitudes and career awareness. A training plan is developed cooperatively between the employer, college and student. (CR/NC grading) 75 hours per semester paid work = 1 unit. 60 hours non-paid (volunteer) work per semester = 1 unit. May be taken for a maximum of 16 units. REQUIRED: Concurrent enrollment in seven or more units (including CWE units, except for summer school. For summer school, enrollment in one other class is required) Minimum 2.00 G.P.A.

80446	Wrk Ex	LI101A	Sweeney S	1.0			
06/01/09 - 08/21/09 Mandatory course orientation for the above class will be conducted Tuesday June 23, 2009 from 530 pm-630 pm in the N/S Lounge, Wednesday, June 24, 2009 from 430 pm -530 pm in the N/S Lounge, and Thursday June 25 from 8 am to 9 am in the N/S Lounge.							
80447	Wrk Ex	LI101A	Sweeney S	2.0			
06/01/09 - 08/21/09 Mandatory course orientation for the above class will be conducted Tuesday June 23, 2009 from 530 pm-630 pm in the N/S Lounge, Wednesday, June 24, 2009 from 430 pm -530 pm in the N/S Lounge, and Thursday June 25 from 8 am to 9 am in the N/S Lounge.							

STAR 2009
 ENROLL NOW
 In Performing Arts Day Camp
 Join the STAR Gilroy Cast of
GREASE
 Music & Lyrics by Jim Jacobs & Warren Casey
 JUNE 22-JULY 18, 2009
 MON-FRI 9 AM-4 PM AGES 8-16
 4 WEEKS * ONLY \$595
 Hands on Acting!
 Kids on Stage!
 ENROLL ONLINE:
 WWW.GAVILAN.EDU/STAR
 OR BY PHONE: (408) 612-2057

**NO QUIZZES!
 NO TESTS!
 NO LETTER GRADES!
 NO FEES!**

Summer Noncredit Classes

This program is open to all students and currently offers various classes of interest to the community.

Registration will take place in the Admissions & Records Office or in class on the first day of the course. Students should contact Debra Casella in the Noncredit Office directly with any questions at (408) 852-2824.

CRN Type Room Instructor Hrs. Units Days Begin-End

ALLIED HEALTH

AH 740 Tai Chi for Arthritis and Other Related Illnesses

Transferable: No

This course is designed for the maintenance of the physical and mental well-being of an older adult with arthritis and other related illnesses. Instruction will focus on the postures and movements of Tai Chi, a Chinese exercise regimen that has a slow paced movement that improves balance, coordination, breathing and builds strength and stamina. Activities are included that promote self-care and health awareness.

80417	Lab	WM1	Yinger K	2.0	TR	1000-1100	
Class meets at Wheeler Manor, 651 W. 6th St., Gilroy.							
80265	Lab	JDA1	Frey E	1.0	R	1115-1215	
Class meets at Jovenes de Antano, 300 West St., Hollister.							

80419	Lab	CRC1	Dunn M	1.0	W	0600-0730	
Class meets at Centennial Recreation Ctr., 171 W. Edmundson Ave., Morgan Hill.							

AH 741 Body Dynamics and Aging

Transferable: No

This course is designed for the 55+ adult student to provide awareness and knowledge of physical fitness, stress management and nutrition to personal health. Discussions will focus on nutrition, sleep disorders, depression, leisure/social activities and chronic conditions that effect the body as aging occurs.

80244	Lec	CRC1	Lee C	1.8	W	1030-1200	
Class meets at Centennial Recreation Ctr., 171 W. Edmundson Ave., Morgan Hill.							

Classroom Locations: Refer to "How to Use This Schedule" on page 5.

CRN Type Room Instructor Hrs. Units Days Begin-End

AH 793 Personal and Career Development

Transferable: No

A wide variety of lectures on general themes offered to students throughout the academic year who want short-formatted content to augment their personal, academic and career development. General themes to be explored are: Communication, Interpersonal Skills, Pre-employment, Decision-Making, Financial Literacy, Career and Personal Development. This noncredit course is a combination of lecture, self-assessments and group activities.

80188	Lab	PB1	TBA	6.0	RF	0900-1200
05/28/09 - 05/29/09						
		PB1	TBA	12.0	MTWR	0900-1200
06/01/09 - 06/11/09 This class was designed for the needs of CalWORKS students.						
80275	Lab	PB1	TBA	9.0	MTW	0900-1200
07/27/09 - 07/29/09						
		PB1	TBA	12.0	MTWR	0900-1200
08/03/09 - 08/20/09 This class was designed for the needs of CalWORKS students.						
80208	Lab	PB1	TBA	7.6	RF	1230-0400
05/28/09 - 05/29/09						
		PB1	TBA	15.2	MTWR	1230-0400
06/01/09 - 06/11/09 This class was designed for the needs of CalWORKS students.						
80273	Lab	SS210	TBA	7.6	RF	1230-0400
05/28/09 - 05/29/09						
		CH105	TBA	15.2	MTWR	1230-0400
06/01/09 - 06/11/09 This class was designed for the needs of CalWORKS students.						
80276	Lab	PB1	TBA	11.4	MTW	1230-0400
07/27/09 - 07/29/09						
		PB1	TBA	15.2	MTWR	1230-0400
08/03/09 - 08/20/09 This class was designed for the needs of CalWORKS students.						
80461	Online	LI100	Sweeney S	6.0	WR	0430-0730
06/15/09 - 07/24/09 This Hybrid lecture/online class will be delivered partially over the internet and also meet face to face at select locations. You must have an email account to take a distance ed course. Unless you have made prior arrangements with the instructor, come to class in person on the first day of the semester or the first day of class for short-term courses. If you do not show up on the first day you may be dropped. For help, contact your instructor or email dited@gavilan.edu.						



ART

ART 760 Arts and Crafts I for Older Adults

Transferable: No

A general survey of arts and crafts with an emphasis on exercises and experiments with methods and materials, including: painting, drawing, color theory, composition and rendering, batik or tie-dye, quilting or needlepoint, crocheting or knitting and block printing.

80030	Lab	WM1	Barrett S	3.0	M	0100-0400
Class meets at Wheeler Manor 651 W. 6th Street, Gilroy. There is a \$25 materials fee for this course.						
80047	Lab	CRC1	Gupta R	3.0	R	0100-0400
Class meets at Centennial Recreation Ctr., 171 W. Edmundson Ave., Morgan Hill. Students will be required to pay for their own art supplies.						

ART 761 Arts and Crafts II for Older Adults

Transferable: No

A general survey of arts and crafts with an emphasis on exercises and experiments with methods and materials, including: Metal, leather, fibers, glass, wood, and paper crafts. The crafts will be for both decorative or utilitarian.

80420	Lab	HVME1	Dickerson P	3.0	F	0930-1230
Class meets at Hacienda Valley Mobile Estates, 275 Burnett Ave., Morgan Hill. Students will be required to pay for their own materials.						

All noncredit classes are open entry/exit and free of charge.

Thinking of online courses at Gavilan College?

Take LIB 732 first!

INTRODUCTION TO ONLINE GAVILAN

A FREE introduction to the world of online education, ONLINE!



Tour the classroom and all the other services available to distance learners - financial aid, library services, tutoring and counseling.

Open entry/open exit means you can jump in or out of class any time you want.

CRN Type Room Instructor Hrs. Units Days Begin-End

COMPUTER SCIENCE & INFORMATION SYSTEMS

CSIS 728 Windows for the Older Adult

Transferable: No

This course is designed as an introductory course for the older adults to learn Windows operations, file management and other Windows Fundamentals.

80148	Lab	HOL3	Staff	2.0	TR	0331-0430
Class meets at the Hollister Briggs site.						
80158	Lab	CTC2	Staff	2.8	T	0900-1130
Class meets at Gavilan Computer Technology Center, Rm. 2, on Murray Ave., Gilroy.						

CSIS 729 Word Processing-MS Word for the Older Adult

Transferable: No

A course designed for older adults (55+) to develop word processing skills to write and edit simple documents, format text, use bullets, create tables, insert clipart and use other features of the toolbar.

80162	Lec	CTC2	Staff	2.8	R	0900-1130
Class meets at Gavilan Computer Technology Center, Rm 2, on Murray Ave., Gilroy.						

ENGLISH

ENGL 756 GED Preparation

This class is taught entirely in Spanish.

Transferable: No

This course is designed to prepare the student to pass the five General Education Development (GED) tests in Writing, Social Studies, Science, Literature and Mathematics. English grammar and usage, reading comprehension, writing, vocabulary and computational skills are emphasized. The course is designed for students who are 18 years of age or older and elect to take the High School Equivalency Examination.

80071	Lab	HOL3	Holguin D	4.0	S	0830-1230
Class meets at the Hollister Briggs site. This class is taught entirely in Spanish.						

Gavilan College off-site locations

HOL	Hollister Briggs Bldg, 365 Fourth St. Hollister
MHG	Morgan Hill Community Center, 17060 Monterey Rd., Morgan Hill

CRN Type Room Instructor Hrs. Units Days Begin-End

ENGLISH AS A SECOND LANGUAGE

ESL 702A ESL Citizenship

Transferable: No

This course is designed for second language learners that want to prepare for the United States Citizenship test given by the Department of Immigration and U. S. Naturalization Services. The focus will be on communicative English skills and knowledge of American History and Government required for passing the test to become a citizen of the United States. Readings are at the high-beginning/low-intermediate ESL level and will focus on the historical period beginning in the 1600's on through to 1980.

80453 Lec MHG5 Yu-Costa E 5.6 MW 0900-1130
Class meets at Morgan Hill Community site.

80060 Lec STF1 Stuker D 3.6 MR 0600-0730
Class meets at St. Frances, 7950 Church St., Gilroy.

80452 Lec JDA1 Segovia M 5.6 TWR 0600-0900
06/02/09-07/09/09 Class meets at Hollister Recreation Center, Gabilan Room 375 5th St., Hollister.

ESL 704A ESL for the Workplace

Transferable: No

This is part A of a content-based integrated skills course for ESL students who want to prepare for immediate entry into the job force. Students expand their language skills within the realm of the work world and specific vocational career of interest while also developing the soft skills needed in the workplace. This course is a combination of lecture, lab, and self-paced instruction.

80167 Lab CTC1 Padilla M 6.0 TWR 0700-0900
Class meets at Gavilan Computer Technology Center, Rm. 1, on Murray Ave., Gilroy.

ESL 777 ESL Lifeskills 1

Transferable: No

This is the first course in a series of survival English classes for students with very little oral or written English competency. It will give students basic vocabulary and familiarity in life skill areas such as the family, food, health, and occupations to manage in the real world. The course emphasizes oral communication and integrates listening, speaking, reading, and writing. ADVISORY: Placement into ESL Lifeskills by the CASAS placement test.

80251 Lec SBCL Kirchner V 6.0 TR 0900-1200
Class meets at San Benito County Library, 470 5th St., Hollister.

80309 Lec MHG13 Yu-Costa E 5.6 TR 0600-0830
Class meets at Morgan Hill Community site.

ESL 778 ESL Lifeskills 2

Transferable: No

This is the second course in a series of classes in survival English for students with very little oral or written English competency. It will give students basic vocabulary and familiarity in life skill areas such as the family, food, health, and occupations to manage in the real world. The course emphasizes oral communication and integrates listening, speaking, reading, and writing. ADVISORY: Placement into ESL Lifeskills by the CASAS placement test and successful completion of ESL 777.

80398 Lec MHG12 Yu-Costa E 5.6 TR 0900-1130
Class meets at Morgan Hill Community site.

All noncredit classes are open entry/exit and free of charge.

CRN Type Room Instructor Hrs. Units Days Begin-End

ESL 779 ESL Lifeskills 3

Transferable: No

This is the third in a series of classes in survival English for students with little oral or written English competency. It will give students expanded basic vocabulary and familiarity in life skill areas such as the weather, transportation, employment, and American holidays and customs to manage in the real world. The course emphasizes oral communication and integrates listening, speaking, reading, and writing. ADVISORY: Placement into ESL Lifeskills by the CASAS placement test and successful completion of ESL 778.

80269 Lec CTC3 Morley S 9.0 MWF 0900-1200
Class meets at Gavilan Computer Technology Center, Rm. 3, on Murray Ave., Gilroy.

ESL 780 ESL Lifeskills 4

Transferable: No

This is the fourth course in a series of survival English for students with little oral or written English competency. It will give students expanded basic vocabulary and familiarity in life skill areas such as weather, transportation, employment, and American holidays and customs to manage in the real world. The course emphasizes oral communication and integrates listening, reading, writing. ADVISORY: Placement into ESL Lifeskills by the CASAS placement test and successful completion of ESL 779.

80400 Lec HOL4 Howell J 5.4 MWF 0600-0730
Class meets at the Hollister Briggs site.

80401 Lec HOL4 Howell J 5.4 MWF 0745-0915
Class meets at the Hollister Briggs site.

HUMANITIES

HUM 767 Film Classics

Transferable: No

This class is designed to study the facts, fantasy, history and trivia of classic and modern films. The background and history of each film and its performance will be compared and contrasted.

80268 Lab JDA Sendejas L 3.0 F 1000-0100
Class meets at Jovenes de Antaño, Calaveras Room in Hollister.

80057 Lab WM1 Sendejas L 3.0 S 0430-0730
Class meets at Wheeler Manor, 651 W. 6th Street, Gilroy.

LIBRARY

LIB 730 Internet Literacy for Older Adults

Transferable: No

A class for older adults to learn email techniques, how to find information on their interests, news sources, and the skill of browsing online, as well as how best to use the local public library online services, online shopping, search strategies, and interactive games.

80106 Lec HOL3 Staff 2.0 TR 0231-0330
Class meets at the Hollister Briggs site.



SUMMER SPORTS CAMPS FOR KIDS!
See ad on page 34.

Late Start/Short-Term Classes

These courses are offered at Gavilan's main Gilroy campus and at the Morgan Hill & Hollister sites. Fall courses begin on page 65.

CRN Type Room Instructor Hrs. Units Days Begin-End

LIB 732 Introduction to Online Gavilan

Transferable: No

Introduction to the online classes and student services at Gavilan College. This course will show students how to log into their online courses, find lectures, assignments and exams, take part in online class discussions, submit attachments, and view their grades. The course will also cover all the online student services available to the distant student, including counseling, library resources, records and grades, financial aid, tutoring and technical support.

80263 ONLINE Parker J

Log in at www.gavilan.edu/disted to access this class any time during the term. You must have an email account to take this course. Start your course by going to www.gavilan.edu/disted. For help, contact your instructor or email disted@gavilan.edu.

LIB 733 Exploring the Web for Older Adults

Transferable: No

Designed to address the interests of older adults, students will learn about the web's rich offering in graphics, sharing digital pictures, and downloading audio files and audiobooks after paying your bills online. Students will learn online techniques to take advantage of all the latest tools, such as wikis, blogs, search techniques and great travel destinations. ADVISORY: LIB 730, Internet Literacy for Older Adults.

80065 Lec HOL3 Staff 2.0 TR 0130-0230

Class meets at the Hollister Briggs site.

PHYSICAL EDUCATION

PE 701 Tai Chi for Wellness

Transferable: No

This course will introduce the student to the thirty seven posture forms and movements of Tai Chi, an ancient Chinese practice that focuses on slow paced coordinated movements that improve balance, coordination, mobility and breathing. The students will also learn how to use this non-contact exercise program to reduce stress in their daily lives.

80266 Lab SJBCC Yinger K 1.0 W 0530-0630

Class meets at San Juan Community Center, 10 San Jose St., San Juan Bautista.

PE 716 Music/Movement and Health

Transferable: No

This course is designed to assist older adults in improving overall health through movement, music and relaxation techniques. Rhythmical movement will be adjusted to suit individual students mobility needs.

80136 Lab CRC1 Mendonca B 4.0 TF 1000-1200

Lab CRC1 Mendonca B 1.0 R 1030-1130

Class meets at Centennial Recreation Ctr., 171 W. Edmundson Ave., Morgan Hill.

80138 Lab GSC1 Mendonca B 1.0 W 1000-1100

Lab GSC1 Mendonca B 1.0 F 0130-0230

Class meets at Gilroy Senior Center 7371 Hanna Street, Gilroy.

80128 Lab JDA1 Host M 1.0 T 1100-1200

Class meets at Jovenes de Antano 300 West St., Hollister.

80129 Lab VPRI Lee C 1.0 T 1030-1130

Lab VPRI Lee C 1.0 W 0930-1030

Class meets at Valley Pines Retirement Inn, 545 E. Main Ave., Morgan Hill.

Gavilan College off-site locations

HOL Hollister Briggs Bldg, 365 Fourth St. Hollister

MHG Morgan Hill Community Center, 17060 Monterey Rd., Morgan Hill

Gilroy

SECT	COURSE	CLASS TITLE	UNITS	DAYS	TIMES	DATES	ROOM
10929	ACCT 121	SPREADSHEET-MS EXCL	2	W	6:00P-9:05P	9/30-12/9	PB4
10394	AH 32	BASIC CARD/LIFE SUP	1	SunSat	9:00A-6:00P	10/10-10/11	HOB114
10399	AH 32	BASIC CARD/LIFE SUP	1	SunSat	9:00A-6:00P	9/12-9/13	HOB114
10402	AH 32	BASIC CARD/LIFE SUP	1	SunSat	9:00A-6:00P	11/7-11/8	HOB114
10350	AH 182	HOME HEALTH CARE	2	Sat	6:30A-1:30P	10/10-11/14	HOB114
10883	CSIS 1	COMPUTER LITERACY	2	Tu	6:00P-9:05P	9/15-12/15	PB3
10224	CSIS 1	COMPUTER LITERACY	2	MW	9:00A-11:05A	9/2-10/21	PB4
10227	CSIS 1	COMPUTER LITERACY	2	MW	9:00A-11:05A	10/26-12/9	PB4
10244	CSIS 10	BASIC PROGRAMMING 2	2	TuTh	9:00A-11:05A	10/15-12/10	LH126
10930	CSIS 121	SPREADSHEET-MS EXCL	2	W	6:00P-9:05P	9/30-12/9	PB4
10855	CSIS 124	WINDOWS FUNDAMENTAL	1	Tu	12:50P-2:10P	9/15-11/24	PB4
10936	ENGL 250	PRACTICAL WRITING	3	TuTh	2:30P-5:40P	10/26-12/19	SS111
				F	1:00P-2:50P	10/26-12/19	LH120
10937	ENGL 250	PRACTICAL WRITING	3	TuTh	2:30P-5:40P	10/26-12/19	SS111
				F	3:00P-4:50P	10/26-12/19	LH120
10833	GUID 1	SELF ASSESSMENT	3	MTuWTh	8:30A-11:40A	7/27-8/20	CH105
10815	GUID 28	TUTORING TECHNIQUE	1	TuTh	8:15A-9:30A	9/1-10/8	PB4A
10382	MATH 205A	FIRST HALF ALGEBRA	2.5	MTuWTh	2:30P-4:35P	9/1-10/24	PH102
10387	MATH 205B	SECOND HALF ALGEBRA	2.5	MTuWTh	2:30P-4:35P	10/26-12/19	PH102
10412	MATH 233A	FIRST HALF INT ALG	2.5	MTuWTh	2:30P-4:35P	9/1-10/24	LS101/CH102
10414	MATH 233B	SECOND HALF INT ALG	2.5	MTuWTh	2:30P-4:35P	10/26-12/19	LS101/CH102
10841	PSYC 5	SELF ASSESSMENT	3	MTuWTh	8:30A-11:40A	7/27-8/20	CH105
10250	PE 1	ORIENT ATHLETE-SUCC	1	MTuWTh	11:30A-1:00P	8/13-8/27	CJ500
10274	PE 17	GOLF	0.5	Sat	9:00A-11:55A	9/5-10/24	ERGOLF*
10456	PE 61	SWIM FOR FITNESS	0.5	TuTh	5:15P-6:35P	9/3-10/22	GY100P
10950	RE 162	RE PRACTICE	3	TuTh	6:30P-9:35P	9/1-10/20	PB13
10951	RE 167	REAL ESTATE ECON	3	TuTh	6:30P-9:35P	10/22-12/15	PB13

* Off campus location. See page 5.

Hollister

SECT	COURSE	CLASS TITLE	UNITS	DAYS	TIMES	DATES	ROOM
10881	ACCT 121	SPREADSHEET-MS EXCL	2	W	6:00P-9:05P	9/30-12/9	HOL3
10801	AMT 100	GEN AIRCRAFT TECH	7.5	Daily	8:00A-10:30A	8/12-12/18	AV102*
10802	AMT 110	AIRFRAME MAINT	13.5	Daily	10:30A-3:30P	8/12-12/18	AV102*
10803	AMT 120	POWERPLANT TECH	14	TuWThF	8:30A-3:00P	8/12-12/18	AV102*
10940	CMUN 129	PRESENTATN GRAPHICS	1	MW	11:20A-1:25P	11/9-12/9	HOL3
10241	CSIS 1	COMPUTER LITERACY	2	MW	11:20A-1:25P	9/14-11/4	HOL3
10243	CSIS 1	COMPUTER LITERACY	2	Th	6:00P-9:05P	09/24-12/10	HOL3
10884	CSIS 10	BASIC PROGRAMMING 2	2	F	9:00A-12:05P	9/18-12/11	HOL3
10882	CSIS 121	SPREADSHEET-MS EXCL	2	W	6:00P-9:05P	9/30-12/9	HOL3
10856	CSIS 124	WINDOWS FUNDAMENTAL	1	MW	9:00A-11:05A	9/14-10/14	HOL3
10858	CSIS 126	WORD PROCESS-MS WRD	2	M	6:00P-9:05P	9/28-12/7	HOL3
10938	CSIS 126	WORD PROCESS-MS WRD	2	MW	9:00A-11:05A	10/19-12/19	HOL3
10939	CSIS 129	PRESENTATN GRAPHICS	1	MW	11:20A-1:25P	11/9-12/9	HOL3

* Off campus location. See page 5.

Morgan Hill

SECT	COURSE	CLASS TITLE	UNITS	DAYS	TIMES	DATES	ROOM
10878	ACCT 121	SPREADSHEET-MS EXCL	2	F	9:00A-12:05P	9/25-12/11	MHG8
10455	CD 28A	CHILD DEV AND GUID	1	Tu	6:00P-9:20P	9/1-9/29	MHG4
10457	CD 28B	DEV LEARNING ACTIVI	1	Tu	6:00P-9:20P	10/6-11/3	MHG4
10460	CD 28C	ADMIN CHLD CARE HOM	1	Tu	6:00P-9:20P	11/10-12/8	MHG4
10880	CSIS 121	SPREADSHEET-MS EXCL	2	F	9:00A-12:05P	9/25-12/11	MHG8
10885	CSIS 126	WORD PROCESS-MS WRD	2	Sat	9:00A-12:20P	10/10-12/12	MHG8

Online

SECT	COURSE	CLASS TITLE	UNITS	DATES
10333	ART 85	WEB DESIGN I: DREAM	2	10/14-12/18
10807	CSIS 3	RESEARCH SKILLS	2	10/14-12/8
10312	CSIS 6	WEBPAGE AUTHORIZING I	2	9/3-10/26
10316	CSIS 6	WEBPAGE AUTHORIZING I	2	10/19-12/12
10322	CSIS 8	INTRO TO INTERNET	1	9/8-10/30
10330	CSIS 8	INTRO TO INTERNET	1	10/26-12/18
10334	CSIS 85	WEB DESIGN I: DREAM	2	10/14-12/18
10315	DM 6	WEBPAGE AUTHORIZING I	2	9/3-10/26
10318	DM 6	WEBPAGE AUTHORIZING I	2	10/19-12/12
10335	DM 85	WEB DESIGN I: DREAM	2	10/14-12/18
10806	LIB 3	RESEARCH SKILLS	2	10/14-12/8
10313	LIB 6	WEBPAGE AUTHORIZING I	2	9/3-10/26
10317	LIB 6	WEBPAGE AUTHORIZING I	2	10/19-12/12
10788	THEA 3	EL TEATRO CAMPESINO	3	10/5-12/19
10778	THEA 20	INTRO SCRIPTWRITING	3	10/5-12/19

DISTANCE LEARNING

courses at Gavilan are offered in three different ways:



Online



Hybrid - online and classroom



Telecourses

Online Courses at Gavilan College

Online courses allow students who have access to a computer with an internet connection to take college credit classes. Students must have an email account before they register for the online course. Students will meet their instructors and classmates online. Your instructor may schedule one or more optional meetings on campus.

BE SURE TO NOTE THE STARTING DATE OF YOUR CLASS.

Unless you have made prior arrangements with the instructor, you **MUST** login by 11:59 pm on the first day of the semester for full-term courses or the first day of class for short-term courses. Late adds must login within 24 hours of adding this course. If you miss the deadline you may be dropped. For help, contact your instructor or email disted@gavilan.edu

ORIENTATIONS: We strongly recommend students take one of the live orientations to online courses offered in the Gavilan Library. Please see the library homepage at: <http://www.gavilan.edu/library/> for a schedule of orientations.

We encourage you to exercise the same kind of caution in a distance learning class as you would if you were taking an on-site class. Do not share personal information about yourself; do not give a stranger or new acquaintance your home phone number or address.

CRN	COURSE	DESCRIPTION	UNITS	BEGIN-END	INTRUCTOR
10163	ACCT 20	FINANCIAL ACCT	4	9/1-12/19	WOLOWITZ
10385	AH 3	PERSON/LIFE CYCLE	3	9/1-12/19	BEDELL
10393	AH 3	PERSON/LIFE CYCLE	3	9/1-12/19	BEDELL
10340	AH 11	NUTRITION	3	9/1-12/19	AKROP
10001	ANTH 1	INTRO PHYSICAL ANTH	3	9/1-12/19	KLEIN
10004	ANTH 1	INTRO PHYSICAL ANTH	3	9/1-12/19	KLEIN
10867	ANTH 9	CHILD FAMILY DIVERSE SOCIETY	3	9/1-12/19	BUMGARNER
10552	ART 6	ART APPRECIATION	3	9/1-12/19	EDBERG
10902	ART 140	BASIC DIGITAL FILM/VIDEO	1	9/1-12/19	BEEDE
10604	CD 2	EARLY CHILD DEVELOP	3	9/1-12/19	BUMGARNER
10465	CD 3	CHILD GROWTH/DEV	3	9/1-12/19	BUMGARNER
10866	CD 7	CHILD FAMILY DIVERSE SOCIETY	2	9/1-12/19	BUMGARNER
10306	CSIS 5	C++ SCIENTIFIC PROG	3	9/1-12/19	VAN TASSEL
10303	CSIS 18	UNIX/C++ PROG	3	9/1-12/19	VAN TASSEL
10304	CSIS 18L	UNIX/C++ PROG LAB	1	9/1-12/19	VAN TASSEL
10297	CSIS 24	JAVA PROGRAMMING I	4	9/1-12/19	VAN TASSEL
10886	CSIS 42	PYTHON PROGRAMMING	4	9/1-12/19	HOWELL
10299	CSIS 45	C++ PROGRAMMING I	4	9/1-12/19	VAN TASSEL
10767	CSIS 48	UNIX/LINUX OP. SYS	4	9/1-12/19	VAN TASSEL
10308	CSIS 54L	PERL PROGRAMMING LB	1	9/1-12/19	TARVIN
10336	CSIS 126	WORD PROCESS-MS WRD	2	9/1-12/19	CONREY
10337	CSIS 132	INTERMEDIATE WORD	2	9/1-12/19	CONREY
10900	CSIS 140	BASIC DIGITAL FILM/VIDEO	1	9/1-12/19	BEEDE
10901	DM 140	BASIC DIGITAL FILM/VIDEO	1	9/1-12/19	BEEDE
10923	ECON 1	PRIN MACROECONOMICS	3	9/1-12/19	TRUONGSON
10117	ENGL 1A	COMPOSITION	3	9/1-12/19	LUOMA
10118	ENGL 1A	COMPOSITION	3	9/1-12/19	CHAFFIN
10121	ENGL 1A	COMPOSITION	3	9/1-12/19	CROOK
10125	ENGL 1B	COMPOSITION & LIT	3	9/1-12/19	RAIMONDO
10126	ENGL 1B	COMPOSITION & LIT	3	9/1-12/19	WARREN
10134	ENGL 1B	COMPOSITION & LIT	3	9/1-12/19	RAIMONDO
10135	ENGL 1C	CRITIC REASON/WRITE	3	9/1-12/19	CHAFFIN
10140	ENGL 1C	CRITIC REASON/WRITE	3	9/1-12/19	ALLISON
10228	ENGL 5A	SURVEY AMER LIT	3	9/1-12/19	SANDLER
10458	GUID 1	SELF ASSESSMENT	3	9/1-12/19	TENNEY
10814	GUID 1	SELF ASSESSMENT	3	9/1-12/19	SHARBONEAU
10405	HE 1	HEALTH EDUCATION	3	9/1-12/19	QUATRE
10376	HE 2	HUMAN SEXUALITY	3	9/1-12/19	QUATRE
10378	HE 2	HUMAN SEXUALITY	3	9/1-12/19	QUATRE
10018	HIST 2	U.S. HISTORY	3	9/1-12/19	GUARDINO
10239	HUM 4	INTRO AMER CINEMA	3	9/1-12/19	RICHARDS
10984	LIB 732*	INTRO TO ONLINE GAVILAN	0	9/1-12/19	PARKER
10435	MATH 5	INTRO STATISTICS	3	9/1-12/19	HAUSSERMANN
10031	POLS 1	INTRO AMERICAN GOVERNMENT	3	9/1-12/19	TURETZKY
10032	POLS 1	INTRO AMERICAN GOVERNMENT	3	9/1-12/19	TURETZKY
10040	POLS 3	INTRO COMPARATIV POLITIC	3	9/1-12/19	TURETZKY
10443	PSCI 2	INTRO METEOROLOGY	3	9/1-12/19	VANTUYL
10609	PSYC 2	EARLY CHILD DEVELOP	3	9/1-12/19	BUMGARNER
10466	PSYC 3	CHILD GROWTH/DEV	3	9/1-12/19	BUMGARNER
10829	PSYC 5	SELF ASSESSMENT	3	9/1-12/19	TENNEY
10832	PSYC 5	SELF ASSESSMENT	3	9/1-12/19	SHARBONEAU
10868	PSYC 7	CHILD FAMILY DIVERSE SOCIETY	3	9/1-12/19	BUMGARNER
10952	RE 165	LEGAL ASPECTS RE	3	9/1-12/19	BANKS
10062	SOC 1A	INTRO TO SOCIOLOGY	3	9/1-12/19	KREIDER
10723	SPAN 12A	SPAN/SPAN SPEAKERS	5	9/1-12/19	MALONE

* Noncredit classes. For more information about Noncredit classes in Hollister see the Noncredit section beginning on page 127.

Fall Online cont.

LATE-START OR SHORT-TERM "CYBERSESSION"

CRN	COURSE	DESCRIPTION	UNITS	BEGIN-END	INSTRUCTOR
10333	ART 85	WEB DESIGN I: DREAM	2	10/14-12/18	LAWRENCE
10807	CSIS 3	RESEARCH SKILLS	2	10/14-12/8	MEADER
10312	CSIS 6	WEBPAGE AUTHORIZING I	2	9/3-10/26	HOWELL
10316	CSIS 6	WEBPAGE AUTHORIZING I	2	10/19-12/12	HOWELL
10322	CSIS 8	INTRO TO INTERNET	1	9/8-10/30	VENABLE
10330	CSIS 8	INTRO TO INTERNET	1	10/26-12/18	VENABLE
10334	CSIS 85	WEB DESIGN I: DREAM	2	10/14-12/18	LAWRENCE
10315	DM 6	WEBPAGE AUTHORIZING I	2	9/3-10/26	HOWELL
10318	DM 6	WEBPAGE AUTHORIZING I	2	10/19-12/12	HOWELL
10335	DM 85	WEB DESIGN I: DREAM	2	10/14-12/18	LAWRENCE
10806	LIB 3	RESEARCH SKILLS	2	10/14-12/8	MEADER
10313	LIB 6	WEBPAGE AUTHORIZING I	2	9/3-10/26	HOWELL
10317	LIB 6	WEBPAGE AUTHORIZING I	2	10/19-12/12	HOWELL
10788	THEA 3	EL TEATRO CAMPESINO	3	10/5-12/19	GONZALEZ
10778	THEA 20	INTRO SCRIPTWRITING	3	10/5-12/19	GONZALEZ

Thinking of online courses at Gavilan College?
Take LIB 732 first!

A FREE introduction to the world of online education...
...ONLINE!

INTRODUCTION TO
ONLINE GAVILAN



Tour the classroom and all the other services available to distance learners - financial aid, library services, tutoring and counseling.

Open entry/open exit means you can jump in or out of class any time you want.

Class is listed in the Noncredit section beginning on page 127.



Hybrid Courses

Hybrid classes will be delivered partially online and also meet face to face at select locations. You must have an email account to take a distance ed course. Unless you have made prior arrangements with the instructor, come to class in person on the first day of the semester or the first day of class for short-term courses. If you do not show up on the first day you may be dropped. For help, contact your instructor or email disted@gavilan.edu.

ACCT 20 Financial Accounting

10161	Lec	PB13	Wolowitz J	4.8	4.0	MW	0250-0500
	Lec	ONLINE	Wolowitz J	1.0			

AH 793* Personal and Career Development

11031	Online	LI100	Sweeney S	6.0		WR	0430-0730
							09/01/09 - 12/31/09

BIO 15 Survey of Human Anatomy and Physiology

10302	Lec	ONLINE	STAFFS		5.0		
	Lab	LS103	STAFFS	3.3		W	0400-0705

CSIS 2 Computers in Business - MS Office

10289		ONLINE	Venable E		4.0		
	Lab	PB3	Bryson M	1.6		T	0945-1105
10292		ONLINE	Venable E		4.0		
	Lab	PB3	Bryson M	1.6		F	0945-1105

CSIS 5 C++ Scientific Programming

10305		ONLINE	Van Tassel D		3.0		
	L/L	MHG8	Van Tassel D	3.3		M	0600-0905

CSIS 24 Java Programming I

10298		ONLINE	Van Tassel D		4.0		
	L/L	LI126	Van Tassel D	3.2		MW	0945-1105

CSIS 45 C++ Programming I

10300		ONLINE	Van Tassel D		4.0		
	L/L	MHG8	Van Tassel D	3.3		M	0600-0905

CSIS 48 UNIX/Linux Operating System

10766		ONLINE	Van Tassel D		4.0		
	L/L	MHG8	Van Tassel D	3.3		T	0600-0905

* Noncredit classes. For more information about Noncredit classes in Hollister see the Noncredit section beginning on page 127.

San Jose State University Telecourses at Gavilan College - Fall 2009

San Jose State University classes begin Monday, August 24 and last day of instruction is Tuesday, December 8, 2009.

Holidays: September 7 (Labor Day), November 13 (Veteran's Day) and November 26 & 27 (Thanksgiving)

There is a \$25 site fee per class to be paid to Gavilan College.

Classes meet in PB11N.

To register for television classes or for more information on dates, times and admission fees, contact: Gavilan College at 408-848-4719 or SJSU 408-924-3624.

Orientation via videoconference will be held on Friday, September 4, 4-5 pm in PB11N.

COURSE#	TITLE	DAY	TIME	INSTRUCTOR
EDCO 266	Education & Career Planning	M	4-6:45PM	Williams
EDCO 215	Intoruduction to Counseling & Guidance	M	7-9:45PM	Beach
EDCO 282	Education Assessment	Tu	4-6:45PM	Aptekar
EDCO 280	Practicum in Multi Counseling	Tu	7-9:45PM	Oliver
EDCO 286	Theory of Organizational Change	W	7-9:45PM	Berta
EDCO 248	Dynamics of Behavior and Development	Th	4-6:45PM	Mraz
EDCO 221	Research Seminar in Education	Th	7-9:45PM	Beach

Hollister Briggs Building

(San Benito County)

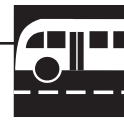

Ride
the
Bus!

We are pleased to provide the following services for your convenience at the Hollister Briggs Building satellite site:

...From Hollister to the Gilroy campus!
County Express--San Benito County Transit
Operating 9 Shuttles Daily
www.sanbenitocountyexpress.org/
(831) 636-4161

- Admissions** Accept applications for admission
Sell catalogs and distribute class schedules
Sell parking permits for the main campus
- Registration and Records** Class registration
Add/drops
Assessment test results
Dispense forms: Transcript Requests, Repeated Course Requests, Progress Reports, High School Contracts, etc.
Sell Student Body IDs (photos taken and cards distributed)
- Orientations** Online
- Placement/Assessment** Assessment tests on a regular basis and Ability to Benefit testing once a month. Check website for times and locations. Schedule an appointment for an ATB test at the Financial Aid Office. Call (408) 848-4727.
- Counseling** Day and evening academic planning and personal counseling services available on Mondays and Tuesdays. Call (831) 636-3783 to schedule an appointment.
- Tutoring** Once a week for Math, English and other subjects. Free to all Gavilan students. Call (831) 636-3783 for times.
- Health Services** First aid supplies and health education materials
- Financial Aid** Assistance with BOG Fee Waiver forms
Assistance with filling out FAFSA and other financial aid information.
- Bookstore** Buy textbooks for your Hollister classes during the first two weeks of the semester.
Order textbooks online at efollet.com, Purchase scantrons and green books.
- Computer Access** Student drop-in lab available to all students registered at Gavilan College. Open during office hours.
Purchase GoPrint cards and reloads.
- Library** A Library resource lab consisting of seven computers allows students to do research.
Help also available via email, chat and phone.
Search e-books, databases and much more.
Open during office hours.
- Career/Transfer** College catalogs, EUREKA career assessment. Every other Monday, drop-in or call (408) 848-4818 to set up appointment.
- EOPS/CalWORKS/CARE** 4:00-5:30 every Wednesday. For more information call (408) 848-4740.
- DRC** Beginning in the fall semester, every second Thursday, 5:30 - 8:00 pm, by appointment. Call (408) 848-4767.

Services for veterans and international students available at the main campus. All other services, including Basic Skills, MESA, and TRIO are available at the Gilroy main campus. Call 408-848-4800. Check catalog or website for complete listings - www.gavilan.edu.



Briggs Building
365 Fourth St.
Hollister, CA 95023
(831) 636-3783

Judy Rodriguez, Instructional Site Director
Natalie Juarez, Program Service Specialist

Site Office Hours: See inside front cover.

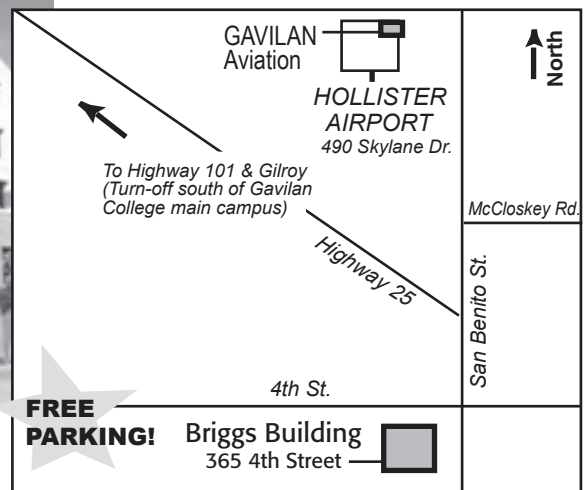

CRN	COURSE	DESCRIPTION	UNITS	DAY	TIMES	BEGIN-END	INTSRUCTOR	ROOM
10174	ACCT 120	COMPUTERIZED ACCTNG	2	F	5:30P-8:35P	9/1-12/19	College	HOL3
10881	ACCT 121	SPREADSHEET-MS EXCL	2	W	6:00P-9:05P	9/30-12/9	Mendez	HOL3
10801	AMT 100	GEN AIRCRAFT TECH	7.5	MTuWThF	8:00A-10:30A	8/12-12/18	Connal	AV102**
10802	AMT 110	AIRFRAME MAINT	13.5	MTuWThF	10:30A-3:30P	8/12-12/18	Hall	AV102**
10803	AMT 120	POWERPLANT TECH	14	TuWThF	8:30A-3:00P	8/12-12/18		AV102**
10859	AMT 123	INDEPENDENT STUDY	1			9/1-12/19	Flippen	AV102**
10474	ART 1A	ART HISTORY	3	M	6:00P-9:05P	9/1-12/19	STAFF	HOL4
10479	ART 21	ANCIENT AMERICAS	3	MW	2:30P-3:50P	9/1-12/19	STAFF	HOL5
10509	ART 25A	ART METHODS	3	F	4:00P-8:05P	9/1-12/19	McGinnis	HOL1
10512	ART 25B	CONCEPT ART METHODS	3	F	4:00P-8:05P	9/1-12/19	McGinnis	HOL1
10908	ART 85	WEB DESIGN I: DREAM	2	M	2:30P-5:35P	9/1-12/19	Lee	HOL3
10280	ASTR 1	INTRO GEN ASTRONOMY	3	Tu	6:00P-9:05P	9/1-12/19	Snyder	HOL1
10181	BOT 180	MEDICAL TERM/OFFICE	3	M	9:45A-12:40P	9/1-12/19	Hardcastle	HOL6
10601	CD 2	EARLY CHILD DEVELOP	3	M	6:00P-9:05P	9/1-12/19	Muscari	HOL5
10514	CD 25A	ART METHODS	3	F	4:00P-8:05P	9/1-12/19	McGinnis	HOL1
10515	CD 25B	CONCEPT ART METHODS	3	F	4:00P-8:05P	9/1-12/19	McGinnis	HOL1
10480	CD 97	INTRO SERV LEARN/CH	3	Th	6:00P-9:05P	9/1-12/19	Brown	HOL1
10580	CMUN 1A	INTRO PUBLIC SPEAK	3	MW	8:10A-9:30A	9/1-12/19	Andrade	HOL2
10569	CMUN 10	SMALL GROUP CMUN	3	MW	9:45A-11:05A	9/1-12/19	Andrade	HOL2
10572	CMUN 10	SMALL GROUP CMUN	3	Th	6:00P-9:05P	9/1-12/19	Andrade	HOL2
10940	CMUN 129	PRESENTATN GRAPHICS	1	MW	11:20A-1:25P	11/9-12/9	Bryson	HOL3
10241	CSIS 1	COMPUTER LITERACY	2	MW	11:20A-1:25P	9/14-11/4	Bryson	HOL3
10243	CSIS 1	COMPUTER LITERACY	2	Th	6:00P-9:05P	9/24-12/10	Thompson	HOL3
10884	CSIS 10	BASIC PROGRAMMING	2	F	9:00A-12:05P	9/18-12/11	Thompson	HOL3
10909	CSIS 85	WEB DESIGN I: DREAM	2	M	2:30P-5:35P	9/1-12/19	Lee	HOL3
10176	CSIS 120	COMPUTER ACCOUNTING	2	F	5:30P-8:35P	9/1-12/19	College	HOL3
10882	CSIS 121	SPREADSHEET-MS EXCL	2	W	6:00P-9:05P	9/30-12/9	Mendez	HOL3
10736	CSIS 122	COMPUTER KEYBOARD	0.5	MW	9:45A-11:05A	9/1-12/19	Bryson	HOL3
10737	CSIS 122	COMPUTER KEYBOARD	1	MW	9:45A-12:40P	9/1-12/19	Bryson	HOL3
10739	CSIS 122	COMPUTER KEYBOARD	0.5	MW	11:20A-12:40P	9/1-12/19	Bryson	HOL3
10741	CSIS 122	COMPUTER KEYBOARD	1	MW	11:20A-1:25P	9/1-12/19	Bryson	HOL3
10751	CSIS 122	COMPUTER KEYBOARD	0.5	Tu	6:00P-7:20P	9/1-12/19	Hampton	HOL3
10752	CSIS 122	COMPUTER KEYBOARD	1	Tu	6:00P-9:05P	9/1-12/19	Hampton	HOL3
10856	CSIS 124	WINDOWS FUNDAMENTAL	1	MW	9:00A-11:05A	9/14-10/14	Bryson	HOL3
10858	CSIS 126	WORD PROCESS-MS WRD	2	M	6:00P-9:05P	9/28-12/7	Mendez	HOL3
10938	CSIS 126	WORD PROCESS-MS WRD	2	MW	9:00A-11:05A	10/19-12/19	Bryson	HOL3
10939	CSIS 129	PRESENTATN GRAPHICS	1	MW	11:20A-1:25P	11/9-12/9	Bryson	HOL3
10910	DM 85	WEB DESIGN I: DREAM	2	M	2:30P-5:35P	9/1-12/19	Lee	HOL3
10892	ECON 1	PRIN MACROECONOMICS	3	F	9:45A-12:50P	9/1-12/19	Sandoval-Hernandez	HOL1
10112	ENGL 1A	COMPOSITION	3	TuTh	11:20A-12:40P	9/1-12/19	Salvin	HOL5
10120	ENGL 1A	COMPOSITION	3	W	6:00P-9:05P	9/1-12/19	Brett	HOL1
10124	ENGL 1A	COMPOSITION	3	F	9:00A-12:05P	9/1-12/19	Mora	HOL5
10133	ENGL 1B	COMPOSITION & LIT	3	MW	4:00P-5:20P	9/1-12/19	Mora	HOL4
10153	ENGL 250	PRACTICAL WRITING	3	TuTh	9:45A-11:05A	9/1-12/19	Salvin	HOL5
				Tu	8:45A-9:35A	9/1-12/19	Salvin	HOL3
10154	ENGL 250	PRACTICAL WRITING	3	TuTh	9:45A-11:05A	9/1-12/19	Salvin	HOL5
				Th	8:45A-9:35A	9/1-12/19	Salvin	HOL3
10196	ENGL 260	PREP/COLLEGE READNG	3	F	9:00A-12:05P	9/1-12/19	Hull	HOL2
10209	ENGL 420	READING IMPROVE	3	TuTh	5:30P-7:35P	9/1-12/19	Parker	HOL5
10222	ENGL 440	BASIC WRITING	3	TuTh	7:45P-9:05P	9/1-12/19	Parker	HOL5
				Tu	9:10P-10:00P	9/1-12/19	Parker	HOL5
10223	ENGL 440	BASIC WRITING	3	TuTh	7:45P-9:05P	9/1-12/19	Parker	HOL5
				Th	9:10P-10:00P	9/1-12/19	Parker	HOL5
10981	ENGL 756*	GED PREPARATION	0	Sat	1:00P-4:00P	9/1-12/19	Miguel	HOL3
10982	ENGL 756*	GED PREPARATION	0	Sat	8:30A-12:30P	9/1-12/19	Miguel	HOL4
10063	ESL 501	SURVIVAL ESL I	6	MTuWThF	11:15A-1:10P	9/1-12/19	STAFF	HOL4
10064	ESL 503	SURVIVAL ESL III	6	MTuWThF	9:10A-11:05A	9/1-12/19	Howell	HOL4
10095	ESL 527	READ-WRITE I	6	MWF	6:30P-8:05P	9/1-12/19	STAFF	HOL6
10812	GUID 1	SELF ASSESSMENT	3	MW	2:30P-3:50P	9/1-12/19	Lopez	HOL2
10014	HIST 1	US HISTORY	3	TuTh	9:45A-11:05A	9/1-12/19	Luna	HOL2
10017	HIST 2	U.S. HISTORY	3	Tu	6:00P-9:05P	9/1-12/19	Luna	HOL2
10020	HIST 2	U.S. HISTORY	3	TuTh	11:20A-12:40P	9/1-12/19	Luna	HOL2
10481	HIST 21	ANCIENT AMERICAS	3	MW	2:30P-3:50P	9/1-12/19	STAFF	HOL5
10371	MATH 205	ELEM ALGEBRA	5	MTuWTh	12:50P-1:55P	9/1-12/19	Knight	HOL5
10374	MATH 205	ELEM ALGEBRA	5	TuTh	6:00P-8:25P	9/1-12/19	Bates	HOL4
10391	MATH 233	INTERMED ALGEBRA	5	MTuWTh	12:50P-1:55P	9/1-12/19	Malokas	HOL1
10893	MGMT 102	RETAIL MANAGEMENT	3	W	6:00P-9:05P	9/1-12/19	Kurtz	HOL4
10722	PHIL 1	INTRO PHILOSOPHY	3	TuTh	2:30P-3:50P	9/1-12/19	Johnston	HOL5
10354	POLS 1	INTRO AMERICAN GOVERNMENT	3	MW	9:45A-11:05A	9/1-12/19	STAFF	HOL5
10044	PSYC 1A	INTRO TO PSYCHOLOGY	3	MW	11:20A-12:40P	9/1-12/19	Oler	HOL2
10047	PSYC 1A	INTRO TO PSYCHOLOGY	3	Th	6:00P-9:05P	9/1-12/19	Oler	HOL2
10602	PSYC 2	EARLY CHILD DEVELOP	3	M	6:00P-9:05P	9/1-12/19	Muscari	HOL5
10828	PSYC 5	SELF ASSESSMENT	3	MW	2:30P-3:50P	9/1-12/19	Lopez	HOL2
10058	SOC 21	MARRIAGE & FAMILY	3	M	6:00P-9:05P	9/1-12/19	Faultt	HOL2
10724	SPAN 1A	ELEMENTARY SPANISH	5	MTuWTh	9:45A-10:50A	9/1-12/19	Perez	HOL1
10738	SPAN 1B	ELEMENTARY SPANISH	5	MTuWTh	8:10A-9:15A	9/1-12/19	Perez	HOL1
10747	SPAN 8A	CONVER SPANISH	3	M	6:00P-9:05P	9/1-12/19	Polo	HOL1
10749	SPAN 8B	CONVER SPANISH	3	W	6:00P-9:05P	9/1-12/19	Lemos	HOL2

Gavilan College offers courses that meet in Morgan Hill and Hollister, including some that meet on weekends and/or start late in the semester. See fall course listings starting on page 65 and consult a counselor for guidance. Students may register online or at any of our three sites.

HOLLISTER CLASSES

* Noncredit classes. For more information about Noncredit classes in Hollister see listings beginning on page 128.

** Meets at Gavilan College Aviation Department, 490 Skylane Drive, Hollister Airport, Hollister. Aviation classes begin August 12, 2009.

We are pleased to provide the following services for your convenience at the Morgan Hill Community Center satellite site:

Admissions Accept applications for admission.
Sell catalogs and distribute class schedules.
Sell parking permits for main campus.

Registration and Records Class registration
Add/drops
Assessment test results
Sell Student Body IDs (photos taken and cards distributed)
Dispense forms: Transcript Requests, Repeated Course Requests, Prerequisite Challenge Forms, etc.

Orientations Online

Placement/Assessment Assessment tests on a regular basis and Ability to Benefit testing once a month. Check website for times and locations.
Schedule an appointment for an ATB test at the Financial Aid Office. Call (408) 848-4727.

EOPS/CalWORKs/CARE 1st & 3rd Thursdays, 8:00-9:30 am. For more information call (408) 848-4740.

DRC Beginning in the fall semester, every third Tuesday, 5:30-8:00 pm, by appointment Call (408) 848-4767.

Tutoring Free to all Gavilan students. Call (408) 782-2873 for times.

Counseling Academic planning and personal counseling services available every Wednesday by appointment. Call (408) 782-2873.

Financial Aid Assistance with BOG Fee Waiver forms
FAFSA and other financial aid forms available online.

Bookstore Buy textbooks for your Morgan Hill classes during the first week of the semester.
Order textbooks online at efollet.com.
Purchase scantrons and bluebooks.

Health Services First aid supplies and health education materials

Library Provides research assistance via email, chat and phone.
Search e-books and databases, and much more.

Career/Transfer College catalogs, EUREKA career assessment. To set up appointment call (408)-848-4818.

Computer Access Student drop-in lab available to all students registered at Gavilan College. Open during office hours.
Purchase GoPrint cards and reloads.

Services for veterans and international students available at the main campus. All other services, including Basic Skills, MESA, TRIO, etc. are available at the Gilroy main campus. Call 408-848-4800. Check catalog or website for complete listings - www.gavilan.edu

Counseling Services

available in Morgan Hill
By appointment only.

Photo ID and Gavilan Student ID are required to obtain counseling services.

Call (408) 782-2873
to schedule
an appointment.

Gavilan College Morgan Hill Site
17060 Monterey Rd.
Morgan Hill, CA 95037
(408) 782-2873

Lorraine Welk, Instructional Site Director
Irma Banuelos, Program Service Specialist

Site Office Hours - See inside front cover.

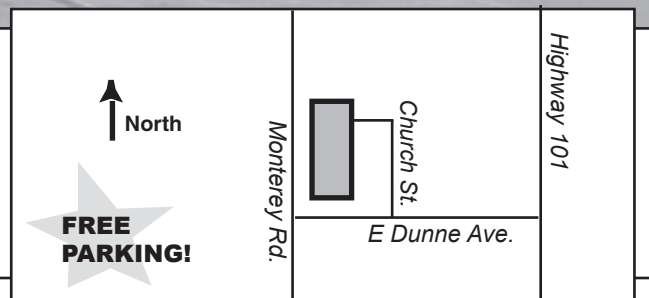

CRN	COURSE	DESCRIPTION	UNITS	DAY	TIMES	BEGIN-END	INSTRUCTOR	ROOM
10762	ACCT 103	GEN OFFICE ACCT	2	Th	6:00P-9:05P	9/1-12/19	Brown	MHG11
10764	ACCT 120	COMPUTERIZED ACCTNG	2	Th	3:00P-5:55P	9/1-12/19	Brown	MHG5
10878	ACCT 121	SPREADSHEET-MS EXCL	2	F	9:00A-12:05P	9/25-12/11	Mendez	MHG8
10082	AJ 10	INTRO ADMIN JUST	3	Th	2:50P-5:55P	9/1-12/19	Smith	MHG13
10072	AJ 12	CRIMINAL PROCEDURE	3	Tu	2:50P-5:55P	9/1-12/19	Smith	MHG13
10076	AJ 18	CMUN/HUMAN RELATION	3	W	6:00P-9:05P	9/1-12/19	Jones	MHG3
10077	AJ 19	INTRO/INVESTIGATION	3	M	6:30P-9:35P	9/1-12/19	Jones	MHG3
10083	AJ 32	CRIME & DELINQUENCY	3	Tu	6:00P-9:05P	9/1-12/19	Pulido	MHG11
10075	AJ 173	FUND OF PROBA/PAROL	3	Th	6:00P-9:05P	9/1-12/19	Pulido	MHG10
10003	ANTH 1	INTRO PHYSICAL ANTH	3	W	6:00P-9:05P	9/1-12/19	Etler	MHG4
10475	ART 1B	ART HISTORY	3	Th	6:00P-9:05P	9/1-12/19	McGinnis	MHG3
10320	ART 74	ADVANCED PHOTOSHOP	3	Th	6:30P-9:35P	9/1-12/19	Grzan	MHG5
10907	ART 75	PHOTOSHOP I	3	Tu	6:30P-9:35P	9/1-12/19	Grzan	MHG5
10888	ART 77	INTRO DIGITAL MEDIA	3	W	6:00P-9:05P	9/1-12/19	Mullins	MHG5
10279	ASTR 1	INTRO GEN ASTRONOMY	3	Tu	6:00P-9:05P	9/1-12/19	Bumgarner	MHG3
10185	BOT 180	MEDICAL TERM/OFFICE	3	W	3:00P-5:55P	9/1-12/19	Knapp	MHG4
10204	BUS 1	FUND OF BUSINESS	3	M	6:00P-9:05P	9/1-12/19	Kurtz	MHG12
10491	CD 1	PRIN/PHIL EC EDUC	3	TuTh	12:50P-2:10P	9/1-12/19	Clabaugh	MHG4
10597	CD 2	EARLY CHILD DEVELOP	3	MW	9:45A-11:05A	9/1-12/19	Bumgarner	MHG4
10449	CD 3	CHILD GROWTH/DEV	3	MW	11:20A-12:40P	9/1-12/19	Bumgarner	MHG4
10485	CD 5	CHILD/FAMILY/COMMUN	3	TuTh	10:45A-12:05P	9/1-12/19	Clabaugh	MHG4
10590	CD 14A	WORK W/SCH AGE CHLD	3	W	6:30P-9:35P	9/1-12/19	Hoshiko	MHG11
10603	CD 20	CHILDREN'S LAN/LIT	3	Th	6:00P-9:05P	9/1-12/19	Malaspina	MHG4
10455	CD 28A	CHILD DEV AND GUID	1	Tu	6:00P-9:20P	9/1-9/29		MHG4
10457	CD 28B	DEV LEARNING ACTIVI	1	Tu	6:00P-9:20P	10/6-11/3	Henrickson	MHG4
10460	CD 28C	ADMIN CHLD CARE HOM	1	Tu	6:00P-9:20P	11/10-12/8	Henrickson	MHG4
10560	CMUN 1A	INTRO PUBLIC SPEAK	3	TuTh	9:45A-11:05A	9/1-12/19	Cowan	MHG3
10559	CMUN 10	SMALL GROUP CMUN	3	TuTh	11:20A-12:40P	9/1-12/19	Cowan	MHG3
10570	CMUN 10	SMALL GROUP CMUN	3	W	6:00P-9:05P	9/1-12/19	Cowan	MHG13
10305	CSIS 5	C++ SCIENTIFIC PROG	0	M	6:00P-9:05P	9/1-12/19	Van Tassel	MHG8
10301	CSIS 18	UNIX/C++ PROG	3	M	6:00P-9:05P	9/1-12/19	Van Tassel	MHG8
10300	CSIS 45	C++ PROGRAMMING I	0	M	6:00P-9:05P	9/1-12/19	Van Tassel	MHG8
10766	CSIS 48	UNIX/LINUX OP. SYS	0	Tu	6:00P-9:05P	9/1-12/19	Van Tassel	MHG8
10309	CSIS 54	PERL PROGRAMMING	3	Th	6:00P-9:05P	9/1-12/19	Tarvin	MHG8
10319	CSIS 74	ADVANCED PHOTOSHOP	3	Th	6:30P-9:35P	9/1-12/19	Grzan	MHG5
10327	CSIS 75	PHOTOSHOP I	3	Tu	6:30P-9:35P	9/1-12/19		MHG5
10889	CSIS 77	INTRO DIGITAL MEDIA	3	W	6:00P-9:05P	9/1-12/19	Mullins	MHG5
10765	CSIS 120	COMPUTER ACCOUNTING	2	Th	3:00P-5:55P	9/1-12/19	Brown	MHG5
10880	CSIS 121	SPREADSHEET-MS EXCL	2	F	9:00A-12:05P	9/25-12/11	Mendez	MHG8
10742	CSIS 122	COMPUTER KEYBOARD	0.5	Sat	8:30A-10:20A	9/1-12/19	Hampton	MHG8
10744	CSIS 122	COMPUTER KEYBOARD	1	Sat	8:30A-12:20P	9/1-12/19	Hampton	MHG8
10885	CSIS 126	WORD PROCESS-MS WRD	2	Sat	9:00A-12:20P	10/10-12/12	Hampton	MHG8
10321	DM 74	ADVANCED PHOTOSHOP	3	Th	6:30P-9:35P	9/1-12/19	Grzan	MHG5
10906	DM 75	PHOTOSHOP I	3	Tu	6:30P-9:35P	9/1-12/19	Grzan	MHG5
10887	DM 77	INTRO DIGITAL MEDIA	3	W	6:00P-9:05P	9/1-12/19	Mullins	MHG5
10890	ECON 1	PRIN MACROECONOMICS	3	M	6:00P-9:05P	9/1-12/19	Shokou	MHG5
10108	ENGL 1A	COMPOSITION	3	MW	8:10A-9:30A	9/1-12/19	Bragger	MHG3
10119	ENGL 1A	COMPOSITION	3	M	6:30P-9:35P	9/1-12/19	Kovacs	MHG11
10137	ENGL 1C	CRITIC REASON/WRITE	3	MW	11:20A-12:40P	9/1-12/19	Luoma	MHG11
10149	ENGL 250	PRACTICAL WRITING	3	TuTh	9:10A-10:30A	9/1-12/19	Sandler	MHG4
				Tu	8:10A-9:00A	9/1-12/19	Sandler	MHG4
10150	ENGL 250	PRACTICAL WRITING	3	TuTh	9:10A-10:30A	9/1-12/19	Sandler	MHG4
				Th	8:10A-9:00A	9/1-12/19	Sandler	MHG4
10173	ENGL 250	PRACTICAL WRITING	3	TuTh	7:00P-8:20P	9/1-12/19	STAFF	MHG12
				Tu	8:30P-9:20P	9/1-12/19	STAFF	MHG12
10175	ENGL 250	PRACTICAL WRITING	3	TuTh	7:00P-8:20P	9/1-12/19	STAFF	MHG12
				Th	8:30P-9:20P	9/1-12/19	STAFF	MHG12
10188	ENGL 260	PREP/COLLEGE READNG	3	TuTh	5:30P-6:50P	9/1-12/19	Hooper	MHG12
10976	ESL 702A*	ESL CITIZENSHIP	0	MW	9:00A-11:30A	9/1-12/19	Yu-Costa	MHG5
10980	ESL 778*	ESL LIFESKILLS 2	0	TuTh	9:30A-11:30A	9/1-12/19	Yu-Costa	MHG13
10010	GEOG 1	PHYSICAL GEOG L/L	3	TuTh	9:45A-12:10P	9/1-12/19	Willahan	MHG12
10406	HE 1	HEALTH EDUCATION	3	W	6:00P-9:05P	9/1-12/19	Dodd	MHG12
10013	HIST 1	US HISTORY	3	MW	9:45A-11:05A	9/1-12/19	Mosher	MHG12
10019	HIST 2	U.S. HISTORY	3	MW	8:10A-9:30A	9/1-12/19	Mosher	MHG12
10434	MATH 5	INTRO STATISTICS	3	MW	6:00P-8:05P	9/1-12/19	Viarengo	MHG13/8
10363	MATH 12	MATH FOR TEACHERS	3	M	6:30P-9:35P	9/1-12/19	Kercheval	MHG10
10368	MATH 205	ELEM ALGEBRA	5	MTuWTh	12:50P-1:55P	9/1-12/19	Kercheval	MHG13
10375	MATH 205	ELEM ALGEBRA	5	TuTh	6:00P-8:25P	9/1-12/19	Butterworth	MHG13
10389	MATH 233	INTERMED ALGEBRA	5	MTuWTh	12:50P-1:55P	9/1-12/19	Potter	MHG10
10949	MKTG 100	PRIN OF MARKETING	3	Sun	4:00P-7:05P	9/1-12/19	Taylor	MHG4
10445	PE 62	YOGA	1	MW	5:00P-6:20P	9/1-12/19	Watson	MHG10/11
10714	PHIL 4	CRITICAL THINK/WRIT	3	MW	2:30P-3:50P	9/1-12/19	Grudzen	MHG12
10600	PSYC 2	EARLY CHILD DEVELOP	3	MW	9:45A-11:05A	9/1-12/19	Bumgarner	MHG4
10453	PSYC 3	CHILD GROWTH/DEV	3	MW	11:20A-12:40P	9/1-12/19	Bumgarner	MHG4
10053	SOC 1A	INTRO TO SOCIOLOGY	3	Tu	6:00P-9:05P	9/1-12/19	Kreider	MHG10

* Noncredit classes. For more information about Noncredit classes in Hollister see listings beginning on page 128.

Gavilan College offers courses that meet in Morgan Hill and Hollister, including some that meet on weekends and/or start late in the semester. See fall course listings starting on page 65 and consult a counselor for guidance. Students may register online or at any of our three sites.

MORGAN HILL CLASSES

GAVILAN  COLLEGE

Service Learning

for community
social change

Sign up for:

AJ 6	# 10029
ANTH 3	# 10007
CMUN 6	# 10028
ECOL 1	# 10361
HIST 3	# 10024
HIST 5	# 10021
POLS 1	# 10034
POLS 6	# 10026
PSYC 6	# 10027
SOC 1B	# 10056

WHAT IS SERVICE LEARNING?

Service Learning connects students and faculty to the community. It's used extensively at four year-colleges from Stanford to the entire CSU and UC systems. In Service Learning classes, students

- work under supervision at a partner agency in the community for 10-40 hours a semester (most Gavilan classes require 20-30 hours, and these hours replace other homework)
- reflectively relate the experience to class content.
- extend the reach, freshen the vision, and aid the work human service agencies do in the community.

Why is Service Learning popular? Students say it...

- makes their classes real.
- gives them an opportunity to contribute in meaningful ways.
- teaches valuable job and life skills.
- can lead to employment offers or better chances to get into the four-year college or career of their choice.

What should I expect in a Service Learning class?

- Your teacher will explain how Service Learning relates to the course goals and orient you to approaches and expectations.
- You will likely have a list of cooperating agencies and you will contact an agency representative to set up an interview.
- The agency will determine your interests and/or your suitability for employment, work out scheduling, and orient you.
- A supervisor will keep track of your hours and guide your work.
- Class assignments will involve and deepen what you are learning at your agency.
- Research shows that your grade, your understanding of course material, and your development as a citizen, voter, and person will all benefit.

Can I take two Service Learning classes at once?

- Students have done this. The key is whether you will be able to use the same service hours at a single agency with two different sets of assignments from two different teachers—a question you can only work out with those teachers, so contact them ahead of time or early in the semester to figure it out.

Why should I take a Service Learning class?

- "I have transformed as an individual and have found my place in the world." – Jeshe W.
- "It definitely brings purpose, excitement and joy to your college experience/adventure." – Chuck H.
- "...it feels good giving out food to people who are in need." – Andre M.



FALL 2009 CLASSES



Classes

- CHN 1A** Elementary Mandarin
- CSIS 42** Python Programming
- FRNH 2A** Intermediate French
- FRNH 8A** Conversational French
- MCTV 16** Television History and Practice
- MCTV 17A** Television and Video Workshop
- MCTV 17B** Television and Video Workshop
- MCTV 19** Television and Film Acting
- MUS 16A** Introduction to Audio Recording Techniques
- PE 78** Dance Repertory
- THEA 78** Dance Repertory

CRN Type Room Instructor Hrs. Units Days Begin-End

ACCOUNTING

ACCT 20 Financial Accounting

Transferable: CSU, UC; CAN:BUS2, BUS SEQ A

An introduction to accounting principles and concepts. The course includes the application of accounting theory to accumulate and summarize financial data. This course has the option of a letter grade or pass/no pass. ADVISORY: Eligible for English 250, English 260 and Mathematics 233. Microsoft Excel or other computer spreadsheet knowledge.

10156	Lec	PB13	Wolowitz J	4.6	4.0	TR	0900-1105
10161	Lec	PB13	Wolowitz J	4.8	4.0	MW	0250-0500
	Lec	ONLINE	Wolowitz J	1.0			

 This Hybrid class will be delivered partially online and also meet face to face at select locations. You must have an email account to take a distance ed course. Unless you have made prior arrangements with the instructor, come to class in person on the first day of the semester or the first day of class for short-term courses. If you do not show up on the first day you may be dropped. For help, contact your instructor or email disted@gavilan.edu.

10163		ONLINE	Wolowitz J	4.0			
-------	--	--------	------------	-----	--	--	--

 You must have an email account to take this course. Start your course by going to www.gavilan.edu/disted. Unless you have made prior arrangements with the instructor, you MUST log on by 11:59 pm on the first day of the semester. Late adds must login within 24 hours of adding this course. If you miss the deadline you may be dropped. For help, contact your instructor or email disted@gavilan.edu.

ACCT 21 Managerial Accounting

Transferable: CSU, UC; CAN:BUS4, BUS SEQ A

This course covers internal uses of accounting information for managerial decision making. Includes coverage of managerial control methods, cost accounting, cost-volume-profit relationships, variable costing, budgeting, and other related topics. This course has the option of a letter grade or pass/no pass. ADVISORY: Accounting 20. Microsoft Excel or other computer spreadsheet knowledge.

10167	Lec	PB13	Wolowitz J	4.8	4.0	TR	1250-0300
10171	Lec	PB13	Wolowitz J	4.0	4.0	MW	0505-0700

CRN Type Room Instructor Hrs. Units Days Begin-End

ACCT 23 Independent Study

Transferable: CSU

Designed to afford selected students specialized opportunities for exploring areas at the independent study level. The courses may involve extensive library work, research in the community, or special projects. May be repeated until six units of credit are accrued. This course has the option of a letter grade or pass/no pass. REQUIRED: The study outline prepared by the student and the instructor must be filed with the department and the dean.

10172	Ind	PB11L	Wolowitz J	1.0			
10177	Ind	PB11L	Wolowitz J	2.0			

ACCT 103 General Office Accounting

Transferable: CSU

This course is designed to prepare students for entry-level office accounting positions. Emphasis is on practical accounting applications. This course has the option of a letter grade or pass/no pass. ADVISORY: Eligible for Mathematics 205.

10089	L/L	PB13	College A	3.3	2.0	F	0900-1205
10762	Lec	MHG11	Brown R	3.3	2.0	R	0600-0905

Above class meets at Morgan Hill Community site.

ACCT 105 Payroll Accounting

Transferable: CSU

An introduction to the calculating, journalizing, paying and reporting of employee earnings, employee withholding and employer payroll tax expenses. The course emphasizes procedures which conform to federal and state legal requirements. This course has the option of a letter grade or pass/no pass. ADVISORY: Eligible for Mathematics 205, completion of Accounting 101.

10763	Lec	HU103	Brown R	3.3	2.0	T	0630-0935
-------	-----	-------	---------	-----	-----	---	-----------

ROP course.

CRN Type Room Instructor Hrs. Units Days Begin-End

ACCT 120 Computerized Accounting - QuickBooks

Transferable: CSU

An introduction to computer-assisted accounting. Hands-on use of a microcomputer menu-driven accounting package to do general ledger, sales journal, cash receipts journal, cash payments journal, purchases journal, payroll, receivables, payables and related financial reports. This course has the option of a letter grade or pass/no pass. Repeatable whenever a new software package is adopted. This course is also listed as CSIS 120. ADVISORY: CSIS 1 or CSIS 2 or the equivalent computer experience. ACCT 20 or ACCT 101 or ACCT 103 or ACCT 105 or the equivalent accounting experience.

10764	L/L	MHG5	Brown R	3.0	2.0	R	0300-0555
Above class meets at Morgan Hill Community site.							

10174	L/L	HOL3	College A	1.3	2.0	F	0530-0835
Above class meets at the Hollister Briggs site.							

ACCT 121 Spreadsheet - MS Excel

Transferable: CSU

Introduction to the computer spreadsheet software. A hands-on approach to learning terms, commands, and applications of a spreadsheet program. This course will help prepare students for taking the Excel MOUS (Microsoft Office User Specialist) exams. This course has the option of a letter grade or pass/no pass. May be repeated once for credit when the software changes. Also listed as CSIS 121. ADVISORY: CSIS 1 or CSIS 2 or equivalent computer experience.

10878	Lec	MHG8	Mendez F	3.3	2.0	F	0900-1205
09/25/09 - 12/11/09 Above class meets at Morgan Hill Community site.							

10881	Lec	HOL3	Mendez F	3.3	2.0	W	0600-0905
09/30/09 - 12/09/09 Above class meets at the Hollister Briggs site. ROP course.							

10929	Lec	PB4	Thompson F	2.0	W	0600-0905	
09/30/09 - 12/09/09							

Acting: see Theatre Arts

ADMINISTRATION OF JUSTICE

AJ 6 Introduction to Conflict Resolution

Transferable: CSU; CSU-GE:D7; GAV-GE:D2

Introduction to Conflict Resolution introduces students to conflict resolution and mediation. Integrating theory and practice, students will assess core concepts about the causes and resolution of conflict, and will practice communication skills for conflict resolution. Students will examine how ethnicity, gender, and class affect power in conflict situations. They will be able to formulate appropriate conflict resolution strategies, and will develop and practice various basic co-mediation skills. This course has the option of a letter grade or pass/no pass. This course is also listed as POLS 6 and PSYC 6 and CMUN 6. ADVISORY: English 250 and English 260.

10029	Lec	SS205	Halper L	3.2	3.0	TR	1250-0210
This service learning section involves community work. See page 64 for details.							

AJ 10 Introduction to the Administration of Justice

Transferable: CSU, UC; CAN:AJ2

The history and philosophy of justice as it evolved throughout the world; in-depth study of the American system and various sub-systems; roles and role expectations of criminal justice agents in their interrelationships in society; concepts of crime causations, punishments and rehabilitation; ethics, education and training for professionalism in the social system. ADVISORY: Eligible for English 250 and English 260.

10070	Lec	PB5	Smith S	3.2	3.0	MW	1120-1240
-------	-----	-----	---------	-----	-----	----	-----------

10082	Lec	MHG13	Smith S	3.3	3.0	R	0250-0555
Above class meets at Morgan Hill Community site.							

What is a CRN?
 CRN stands for Course Reference Number. This is the number (used to be called section) that you will use to register for your classes.

CRN Type Room Instructor Hrs. Units Days Begin-End

AJ 12 Criminal Procedures

Transferable: CSU

Legal processes from pre-arrest, arrest through trial, sentencing and correctional procedures; a review of the history of case and common law; conceptual interpretations of law as reflected in court decisions; a study of case law methodology and case research as the decisions impact upon the procedures of the justice system. ADVISORY: Eligible for English 250 and English 260.

10072	Lec	MHG13	Smith S	3.3	3.0	T	0250-0555
Above class meets at Morgan Hill Community site.							

AJ 14 Criminal Law

Transferable: CSU, UC; CAN:AJ4

Historical development, philosophy of law and constitutional provisions; definitions, classifications of crime, and their applications to the system of administration of justice; legal research, review of case law, methodology, and concepts of law as a social force. Explores crimes against persons, property, and the state. ADVISORY: Eligible for English 250 and English 260.

10073	Lec	PB5	Smith S	3.2	3.0	MW	0230-0350
-------	-----	-----	---------	-----	-----	----	-----------

AJ 16 Introduction to Evidence

Transferable: CSU

Origin, development, philosophy and constitutional basis of evidence; constitutional and procedural considerations affecting arrest, search and seizure; kinds and degrees of evidence and rules governing admissibility; judicial decisions interpreting individual rights and case studies viewed from a conceptual level. ADVISORY: Eligible for English 250 and English 260.

10074	Lec	PB5	Campos E	3.2	3.0	TR	1120-1240
-------	-----	-----	----------	-----	-----	----	-----------

AJ 18 Community and Human Relations

Transferable: CSU, UC

The relationship of criminal justice agents and the community; causal and symptomatic aspects of community understanding; lack of cooperation and mistrust; study of behavioral causes; ways to develop and maintain amicable relationships. ADVISORY: Eligible for English 250 and English 260.

10076	Lec	MHG10	Jones W	3.3	3.0	W	0630-0935
Above class meets at Morgan Hill Community site.							

AJ 19 Introduction to Investigation

Transferable: CSU

Fundamentals of investigation; techniques of crime scene search and recording; collection and preservation of physical evidence; modus operandi processes; sources of information; interview and interrogation, and follow-up investigation. ADVISORY: Eligible for English 250 and English 260.

10077	Lec	MHG3	Jones W	3.3	3.0	M	0630-0935
Above class meets at Morgan Hill Community site.							

AJ 20 Juvenile Law and Procedure

Transferable: CSU

Techniques of handling juvenile offenders and victims; prevention and repression of delinquency; diagnosis and referral; organization of community resources. Juvenile law and juvenile court procedure. ADVISORY: Eligible for English 250 and English 260.

10081	Lec	PB5	Campos E	3.2	3.0	TR	0945-1105
-------	-----	-----	----------	-----	-----	----	-----------

Need a Book Loan?

With an ASB card you can apply for an ASB book loan (up to \$300) at the Financial Aid Office, room SC124.

Buy an ASB card at the Admissions & Records Office, room SC111.



CRN Type Room Instructor Hrs. Units Days Begin-End

AJ 21 Narcotics and Drug Abuse

Transferable: CSU

Designed to explore the Administration of Justice system and drug problems: drug identification, drug user recognition, drug effects, narcotic enforcement, drug prosecution, drug treatment, rehabilitation and education. ADVISORY: Eligible for English 250 and English 260.

10071 Lec PB5 Smith S 3.2 3.0 MW 0945-1105

AJ 32 Crime and Delinquency

Transferable: CSU

An introduction to major types of criminal behavior, characteristics of offenders, factors which contribute to crime and delinquency; the criminal justice process: the function of law enforcement, the courts, probation, parole and institutions; changes in crime control and treatment processes, the role of society. ADVISORY: Eligible for English 250 and English 260.

10083 Lec MHG11 Pulido D 3.3 3.0 T 0600-0905
Above class meets at Morgan Hill Community site.

AJ 173 Fundamentals of Probation and Parole

Transferable: CSU

Theory and techniques of probation/parole supervision, including historical development with emphasis on recent programs, research, and development in the field. ADVISORY: Eligible for English 250 and English 260.

10075 Lec MHG10 Pulido D 3.3 3.0 R 0600-0905
Above class meets at Morgan Hill Community site.

AJ 190 Occupational Work Experience/Administration of Justice

Transferable: CSU

College credit for learning experience obtained on the job in accordance with a training plan developed cooperatively between the employer, college and student. 75 hours per semester per unit or 60 hours per semester for unpaid experience. This is a pass/no pass course. May be taken for a maximum of 16 work experience units. REQUIRED: Declared vocational major. Concurrent enrollment in seven or more units (including CWE units, except for summer school. For summer school, enrollment in one other class is required). Minimum 2.00 G.P.A.

Mandatory course orientation for the following classed will be conducted Tuesday October 6, 2009 from 530 pm-630 pm the North/South Lounge, Wednesday, October 7, 2009 from 430 pm -530 pm in the North/South Lounge and Thursday October 8, 2009 from 8 am to 9 am in the North/South Lounge. Students need to attend one of the three meetings. Please contact Susan Sweeney, CWE Coordinator at (408) 848-4813 for more information.

10079 Wrk Ex LI101A Sweeney S 1.0
10080 Wrk Ex LI101A Sweeney S 2.0
10087 Wrk Ex LI101A Sweeney S 3.0
10088 Wrk Ex LI101A Sweeney S 4.0

ALLIED HEALTH

AH 3 The Person in the Life Cycle

Transferable: CSU, UC; CSU-GE:E2; GAV-GE:E2, F

Interaction of social, emotional, intellectual, and physical attributes related to the development and realization of human potential across the life span. PREREQUISITE: Eligible for English 250 and English 260.

10352 Lec LS106 Logan C 3.3 3.0 R 1250-0355

10353 Lec LS106 Dufresne A 3.3 3.0 R 0400-0705

10385 ONLINE Bedell K 3.0

 You must have an email account to take this course. Start your course by going to www.gavilan.edu/disted. Unless you have made prior arrangements with the instructor, you MUST log on by 11:59 pm on the first day of the semester. Late adds must login within 24 hours of adding this course. If you miss the deadline you may be dropped. For help, contact your instructor or email disted@gavilan.edu.

10393 ONLINE Bedell K 3.0

 You must have an email account to take this course. Start your course by going to www.gavilan.edu/disted. Unless you have made prior arrangements with the instructor, you MUST log on by 11:59 pm on the first day of the semester. Late adds must login within 24 hours of adding this course. If you miss the deadline you may be dropped. For help, contact your instructor or email disted@gavilan.edu.

Certificate of Proficiency

Computerized Accounting

16 units

Learn Computerized bookkeeping skills for a modern office.

ACCT/CSIS 120
Computerized Accounting

using *QuickBooks Pro*

Business Accounting Software



Now offered in Morgan Hill and Hollister.

Content includes general ledger, sales journal, cash receipts journal, cash payments journal, purchases journal, payroll, receivables, payables and related financial reports.



Gavilan College in partnership with the County of Santa Clara offers public safety training for careers in Law Enforcement and Probation. Classes are held at the Harold Holden Justice Training Center in Morgan Hill.

For more information contact:

Linda Mirch
Sr. Training & Staff Development Specialist
Santa Clara County Probation Department
(408) 435-2144

Clay Fontes
Sr. Training Specialist
Santa Clara County Sheriff's Office
(408) 201-7643



Gavilan College has been providing quality Administration of Justice education and training for over 40 years. So, when you want to begin your career in Law Enforcement, you can go to the same place where thousands of Northern California law enforcement officers got their start!

Gavilan College is a member of the South Bay Regional Public Safety Training consortium. This consortium is funded by all colleges regionally to provide vocational specific training which may require special facilities, special training conditions or is presented outside of schedules of regular college classes.

Careers in:

- Law Enforcement
- Probation Officer
- Corrections Officer
- Fire Technology
- Dispatcher
- Juvenile Hall Counselor



www.gavilan.edu/aj
or call (408) 270-6458

CRN Type Room Instructor Hrs. Units Days Begin-End

AH 11 Nutrition

Transferable: CSU, UC; CSU-GE:E2; GAV-GE:E2, F; CAN:FCS2

This course is designed to meet the needs of the Allied Health student and the general education student alike. The major aim of this course is to help the student acquire relevant information about nutrition which they can use professionally and/or personally. The course will cover the practical aspects of normal nutrition, ways to promote sound eating habits throughout the life cycle, and physiological contribution nutrients make to body structure and function. This course is also listed as BIO 11. PREREQUISITE: Eligible for English 250 and English 260. ADVISORY: Chemistry 30A and Mathematics 205.

10338	Lec	LS106	Akrop M	3.3	3.0	T	1250-0355
10339	Lec	LS106	Akrop M	3.3	3.0	T	0400-0705
1034		ONLINE	Akrop M		3.0		

You must have an email account to take this course. Start your course by going to www.gavilan.edu/disted. Unless you have made prior arrangements with the instructor, you MUST log on by 11:59 pm on the first day of the semester. Late adds must login within 24 hours of adding this course. If you miss the deadline you may be dropped. For help, contact your instructor or email disted@gavilan.edu.

AH 23 Independent Study

Transferable: CSU

Designed to afford selected students specialized opportunities for exploring areas at the independent study level. The courses may involve extensive library work, research in the community, or special projects. May be repeated until six units of credit are accrued. This course has the option of a letter grade or pass/no pass. REQUIRED: The study outline prepared by the student and the instructor must be filed with the department and the dean.

10618	Ind	HOB107	Bedell K		1.0		
-------	-----	--------	----------	--	-----	--	--

AH 32 Basic Cardiac Life Support

Transferable: CSU

Course designed to teach students skills in adult, child and infant cardiopulmonary resuscitation. Specifically designed for health professionals. Successful completion will result in certification by the American Heart Association or American Red Cross. This is a pass/no pass course. May be repeated up to three times for credit. \$12.00 course material fee. Additional \$5.00 due upon completion for certification card.

10394	Lec	HOB114	Logan C	18.0	1.0	US	0900-0600
							10/10/09 - 10/11/09
10399	Lec	HOB114	Logan C	18.0	1.0	US	0900-0600
							09/13/08 - 09/14/09
10402	Lec	HOB114	Logan C	18.0	1.0	US	0900-0600
							11/07/09 - 11/08/09

AH 51 Medical-Surgical Nursing

Transferable: CSU

Course is designed to provide a basic introduction to patient care within the role of the nurse. Emphasizes principles and skills necessary for safe, effective care. Content includes introduction to health care, effective communication, client rights and needs, asepsis, personal care, safety, and gerontology. Related pharmacology is included. \$100 course material fee, payable at registration. PREREQUISITE: Admission to the nursing program.

10610	L/L	HOB102	Stubblefield L	15.6	11.0	MT	0630-0200
	L/L	HOB102	Bedell K	6.0		WR	0710-1000

AH 53 Medical-Surgical/Maternal-Neonatal Nursing

Transferable: CSU

Course contains two components to provide theoretical and clinical experience in medical-surgical and maternal-neonatal nursing. Content includes care of clients with disorders of the circulatory, urinary and reproductive systems, normal pregnancy and birth, common or major complications, care of the normal newborn, and neonate with special problems. Related pharmacology is included. PREREQUISITE: Successful completion of Allied Health 61 and 62 with a grade of C or better or equivalent. Equivalency determined by written and performance exams. \$100 course material fee, payable at registration.

10963	L/L	HOB102	Amaro D	15.6	11.0	MT	0200-0930
	L/L	HOB102	Amaro D	15.6		MT	0630-0200
	L/L	HOB102	Bedell K	6.0		WR	0110-0400

CRN Type Room Instructor Hrs. Units Days Begin-End

AH 55 Interactive and Mental Health Nursing

Transferable: CSU

The dynamics of leadership and management in nursing, including concepts of basic mental health. Progresses from basic mental health knowledge and skills to the refinements involved in psychiatric nursing practice as it relates to all age groups. Incorporates nursing concepts and nursing experiences relative to human sexuality, child abuse and cultural and ethnic diversity. PREREQUISITE: Admission to the RN program and California IV certification. \$100 course material fee, payable at registration.

10962	L/L	HOB102	Turner S	13.8	10.0	MT	0130-0815
	L/L	HOB102	Turner S	11.8		MT	0200-0845
	L/L	HOB102	Bedell K	6.0		WR	1010-0100

AH 170 Basic Clinical Medical Assisting

Transferable: CSU

Course provides a basic introduction to clinical medical assisting. Emphasizes principles, understanding of skills necessary to perform basic clinical medical assisting procedures safely and effectively. PREREQUISITE: Eligible for English 250, English 260 and Mathematics 205.

10341	L/L	HOB114	Arballo C	13.8	6.0	TWR	1250-0420
							ROP course.

AH 180 Fundamentals of Nursing--Convalescent

Transferable: CSU

A course to provide a basic introduction to patient care in the convalescent setting. Emphasizes principles, understanding and skills necessary to perform basic nursing procedures safely and effectively. Includes introduction to health care, planning, safety, infection control, personal care, basic procedures, rehabilitation, nutrition and clients' rights and needs. At the completion of this course students will qualify for state certification as a nursing assistant. PREREQUISITE: Eligible for English 250 and English 260. Clearance from the Department of Health Services (Form HS283), fingerprint card, and health clearance required prior to clinical placement. Health and fingerprint clearance required prior to clinical placement. Uniform, shoes, watch, and stethoscope required. Clinical in Morgan Hill or Hollister, as assigned.

10343	L/L	HOB114	Machado M	6.0	8.0	MT	0910-1200
	L/L	HOB114	TBA	7.0		W	0630-0130
							ROP course.
10344	L/L	HOB114	Machado M	6.0	8.0	MT	0900-1200
	L/L	HOB114	TBA	7.0		R	0630-0130
							ROP course.

AH 182 Home Health Care

Transferable: CSU

Course is designed to prepare students to provide basic health care in the home. Includes interpretation of medical/social needs, personal care services, cleaning tasks, nutrition, and the scope of limitations of a home health aide. All students who achieve a grade of "C" or better will be eligible for a Home Health Aide certificate from the State of California. PREREQUISITE: California CNA certification or concurrent enrollment in AH 180 or equivalent. Equivalency determined by written and performance exams. Also, eligible for English 250 and English 260. Clearance from the Department of Health Services (Form HS283), fingerprint card, and health clearance required prior to clinical placement.

10350	L/L	HOB114	Machado M	7.0	2.0	S	0630-0130
							10/10/09 - 11/14/09

AH 190 Occupational Work Experience/Allied Health

Transferable: CSU

College credit for learning experience obtained on the job in accordance with a training plan developed cooperatively between the employer, college and student. 75 hours per semester per unit or 60 hours per semester for unpaid experience. This is a pass/no pass course. May be taken for a maximum of 16 work experience units. REQUIRED: Declared vocational major. Concurrent enrollment in seven or more units (including CWE units, except for summer school. For summer school, enrollment in one other class is required). Minimum 2.00 G.P.A. Please contact the Allied Health Department at (408) 848-4883 for more information.

10409	Wrk Ex	HOB114	Bedell K				1.0
10411	Wrk Ex	HOB114	Bedell K				2.0
10413	Wrk Ex	HOB114	Bedell K				3.0
10415	Wrk Ex	HOB114	Bedell K				4.0

CRN Type Room Instructor Hrs. Units Days Begin-End

Anatomy: see Biological Sciences

ANTHROPOLOGY

ANTH 1 Introduction to Physical Anthropology

Transferable: CSU, UC; CSU-GE:B2, IGETC:5B; GAV-GE:B2; CAN:ANTH2

Explores and analyzes human biological, social and cultural development over the last several million years. The implications of evolutionary theory for the world today are considered. Principal topics are evolutionary theory, Mendelian and molecular genetics, the fossil record, primatology, the nature of human diversity, biocultural analysis of malnutrition, and the question of continuing evolution. ADVISORY: English 250, English 260 and Mathematics 205.

10002 Lec SS210 Klein D 3.2 3.0 MW 1250-0210

10003 Lec MHG4 Etler D 3.3 3.0 W 0600-0905
Above class meets at Morgan Hill Community site.

10001 ONLINE Klein D 3.0

You must have an email account to take this course. Start your course by going to www.gavilan.edu/disted. Unless you have made prior arrangements with the instructor, you MUST log on by 11:59 pm on the first day of the semester. Late adds must login within 24 hours of adding this course. If you miss the deadline you may be dropped. For help, contact your instructor or email disted@gavilan.edu.

10004 ONLINE Klein D 3.0

You must have an email account to take this course. Start your course by going to www.gavilan.edu/disted. Unless you have made prior arrangements with the instructor, you MUST log on by 11:59 pm on the first day of the semester. Late adds must login within 24 hours of adding this course. If you miss the deadline you may be dropped. For help, contact your instructor or email disted@gavilan.edu.

ANTH 2 Introduction to Archaeology

Transferable: CSU, UC; CSU-GE:D1, IGETC:4A; GAV-GE:D2

Introduction to history and development of the concepts and methods of anthropological archaeology, a survey of selected prehistoric cultures, and some training in archaeological survey methods, site recognition, recordation and preservation as well as cultural resource management. ADVISORY: Recommended English 250 and English 260.

10005 Lec SS210 Etler D 3.2 3.0 MW 1120-1240

ANTH 3 Introduction to Cultural Anthropology

Transferable: CSU, UC; CSU-GE:D1, IGETC:4A; GAV-GE:D2, F; CAN:ANTH4

The comparative study of human societies and cultures. Emphasis is placed on the analysis of small scale non-western societies. Specific topics include: the relationship between culture and power; ideas of progress and the nation-state; immigration, kinship, and identity; race and gender; inequality and structural violence; and cross-cultural analysis of religious, political and economic institutions. This course interrogates the relevance of anthropology for understanding the processes of development and globalization. Exploration of the above through ethnographic readings, class discussions, films, short papers and a final research paper based on original fieldwork in a local community. ADVISORY: Eligible for English 250 and English 260.

10006 Lec SS205 Michaels G 3.2 3.0 TR 0945-1105

10007 Lec SS205 Klein D 3.2 3.0 MW 0230-0350
This service learning section involves community work. See page 64 for details.

ANTH 5 Magic/Witchcraft and Religion

Transferable: CSU, UC; CSU-GE:D1, IGETC:4A; GAV-GE:D2

Explores and analyzes, from a cross-cultural and comparative perspective, religious traditions in diverse cultural contexts with particular focus on the effects of globalization on religious beliefs and practices. Cross-cultural analysis of the concepts of magic, witchcraft, and religion. Examination of connections among the concepts of race, nation, and religion. Exploration of the above through ethnographic readings, class discussions, films, short papers, and a final research paper based on original fieldwork in a local religious or spiritual community. ADVISORY: English 250 and English 260.

10008 Lec SS205 Michaels G 3.2 3.0 TR 1120-1240

Be Aware

You MAY NOT take courses that overlap (courses that meet at the same day and time)!

**Faculty! Staff! Students!
Working Parents! Community!**



Gavilan College has the only accredited child care facility in Gilroy!

NAEYC #430703716 & #434400444

FEE-BASED SERVICE

**6 wks - 5 yrs
6:30 am - 6:00 pm**

HALF-DAY PROGRAM Parents do not have to be students!

Call the Child Development Center at 408-848-4815 for more information.

Gavilan's Child Development Center will accept payment from other subsidized programs (i.e., 4C's, Choices for Children) Personal payment also accepted.



Providing lifelong learning opportunities to people of all ages!

- short-term
- not-for-credit

Have fun with learning to dance. Learn quick tips in Word, Excel, QuickBooks. Explore your creativity in Drawing and Painting.

Want to teach? For more information or to teach for us, go to our website at <http://gavilan.augusoft.net> and click on teaching or call us at (408) 847-2514, ext. 1.

Need training for your employees? Contract Education provides professional development opportunities for your staff and managers.

Whether you are looking for ESL or Supervision, Workplace Spanish, Leadership Skills or other training, we can help.

Call us at (408) 847-2514, ext. 3.

CRN Type Room Instructor Hrs. Units Days Begin-End

ANTH 9 Cultural Context of Child & Family in a Diverse Society

Transferable: CSU; CSU-GE:D7; GAV-GE:D2, F

Examines cultural influences on child-rearing practices, family values, and human development. Perspectives from social sciences are used to critique and review theoretical and practical implications of oppression and privilege as they apply to families, schools, and communities, including historical and socio-cultural factors. The processes of socialization and identity development, and the importance of respectful, reciprocal relationships that support and empower families. Self-examination and reflection on issues related to social identity, stereotypes and bias, social and educational access, media and schooling. Also listed as CD 7 and PSYC 7. ADVISORY: Eligible for English 250 and English 260.

10867 ONLINE Bumgarner M 3.0

 You must have an email account to take this course. Start your course by going to www.gavilan.edu/disted. Unless you have made prior arrangements with the instructor, you MUST log on by 11:59 pm on the first day of the semester. Late adds must login within 24 hours of adding this course. If you miss the deadline you may be dropped. For help, contact your instructor or email disted@gavilan.edu.

ART

ART 1A Art History

Transferable: CSU, UC; CSU-GE:C1, IGETC:3A; GAV-GE:C1; CAN:ART2, ART SEQ A

A critical survey of the influences and development of painting, architecture, sculpture, and minor arts from pre-history to the Byzantine/Romanesque eras, including the art of primitive people. ADVISORY: Eligible for English 250 and English 260.

10476 Lec AL101 Hulin P 3.2 3.0 TR 1120-1240

10474 Lec HOL4 STAFF S 3.3 3.0 M 0600-0905

Above class meets at the Hollister Briggs site.

ART 1B Art History

Transferable: CSU, UC; CSU-GE:C1, IGETC:3A; GAV-GE:C1; CAN:ART4, ART SEQ A

The history of western painting, sculpture, architecture and minor arts from the Romanesque, the Gothic and Renaissance eras to the present. ADVISORY: Eligible for English 250 and English 260.

10475 Lec MHG3 McGinnis R 3.3 3.0 R 0600-0905

Above class meets at Morgan Hill Community site.

ART 2A Two-Dimensional Design

Transferable: CSU, UC; CSU-GE:C1; GAV-GE:C1; CAN:ART14

An introduction to the basic elements and principles of two-dimensional design. Lettering and graphics applications of design are included. Traditional and experimental materials and techniques are applied to a variety of individual projects and exercises.

10521 L/L AR103 Thomas B 6.6 3.0 TR 0810-1115

ART 3A Drawing and Composition

Transferable: CSU, UC; CSU-GE:C1; GAV-GE:C1; CAN:ART8

A course that can teach you how to draw. Students learn basic drawing skills through the exploration of a variety of drawing materials such as pencil, inks, charcoal and pastels; processes include doodling, gesture and schematic drawing.

10530 L/L AR102 Rosette A 6.6 3.0 MW 0810-1115

10533 L/L AR102 STAFF S 6.6 3.0 TR 0810-1115

CRN Type Room Instructor Hrs. Units Days Begin-End

ART 3B Drawing and Composition

Transferable: CSU, UC; GAV-GE:C1

Drawing in pencil, ink, pastels and variety of experimental materials and processes. Cultural awareness and historical foundations are integrated with classroom explorations of expressive drawing. Students develop a variety of drawing approaches and a greater understanding of personal expression. May be repeated once for credit. This course has the option of a letter grade or pass/no pass. ADVISORY: Art 2A or 3A.

10532 L/L AR102 Rosette A 6.6 3.0 MW 1120-0225

ART 6 Art Appreciation

Transferable: CSU, UC; CSU-GE:C1, IGETC:3A; GAV-GE:C1

An illustrated lecture course that surveys and introduces the visual arts from historical to contemporary times, and teaches students the basic concepts of seeing and appreciating art. ADVISORY: English 250 and English 260.

10551 Lec AR103 Edberg J 3.2 3.0 MW 1120-1240

10552 Online ONLINE Edberg J 3.0

ART 8A Beginning Photography from Analog to Digital

Transferable: CSU, UC; CSU-GE:C1; GAV-GE:C1; CAN:ART18

A beginning photography course focused on the technical and historical aspects of photography from analog to digital. This course includes the development of personal artistic expression and visual perception through the use of various photographic medium. The course will include lectures and discussions about composition and content, analog and digital camera use, lighting and exposure, various photographic processes, and photographic presentation techniques. Alternative methods, mixed media and experimental forms of photography will also be discussed. Students will be required to provide their own camera, and film.

10557 L/L AR103 Edberg J 6.6 3.0 TR 1120-0225

ART 10A Cultural History of Ceramics

Transferable: CSU, UC; CSU-GE:C1; GAV-GE:C1, F; CAN:ART6

An introduction to the historical developments and cultural influences of ceramic art. Development of a personal expression is realized through the combination of historical elements, observation and actual creations in clay.

10462 L/L AR101 Rekedal J 6.6 3.0 MW 0810-1115

10464 L/L AR101 Rekedal J 6.6 3.0 MW 1120-0225

10467 L/L AR101 Gonzales K 6.6 3.0 TR 0600-0905

ART 10B Ceramics

Transferable: CSU, UC; GAV-GE:C1

Emphasis on development of wheel throwing and advanced ceramic techniques. Glaze testing, clay body development, kiln stacking and firing are introduced. May be repeated three times for credit. This course has the option of a letter grade or pass/no pass. ADVISORY: Art 10A

10468 L/L AR101 Gonzales K 6.6 3.0 TR 0600-0905

ART 11 Creativity/Imagination and Innovation

Transferable: CSU; CSU-GE:C2; GAV-GE:C2, F

This course is designed to explore the variety of ways in which humans demonstrate their creative, imaginative and innovative abilities. This course will examine the creative process, visual literacy, the development of creative and imaginative performance and theories pertaining to insight, inspiration, intuition, originality and genius. This class draws on materials from a variety of sources including, biographies, intellectual histories, psychological studies, and educational research. Studies will include ideas and beliefs about creativity from a diverse range of disciplines and cultures. Students will be encouraged to explore and express their own creativity. ADVISORY: English 250 and English 260.

10469 Lec AL101 Juncker A 3.2 3.0 TR 0945-1105

ART 12A Sculpture

Transferable: CSU, UC; GAV-GE:C1; CAN:ART12

An introduction to expressive and technical sculptural processes of selected media such as clay, plaster and wood. May be repeated twice for credit. This course has the option of a letter grade or pass/no pass.

10942 L/L AR101 Hulin P 6.6 3.0 TR 0810-1115

Social security numbers are no longer used as student identifiers. Find your new Gavilan Student ID number and choose a log-on PIN by going to www.gavilan.edu and clicking on the Self-Service Banner icon. You will use your new ID number and PIN to log into Self-Service Banner and register for summer and fall classes.

Classroom Locations: Refer to "How to Use This Schedule" on page 5.

CRN Type Room Instructor Hrs. Units Days Begin-End

ART 13 Three-Dimensional Design

Transferable: CSU, UC; CSU-GE:C1; GAV-GE:C1

A fundamental course focused on the technical and historical aspects of three dimensional design and sculpture. Development of personal artistic expression and visual perception through the use of various sculpting media such as plaster, paper, wood, clay, metal, etc. Introduction to the design elements and principles as they relate to space and form in visual art and design will be studied. ADVISORY: English 250 and English 260.

10470 L/L AR101 Hulin P 6.6 3.0 TR 0810-1115

ART 14 Beginning Mural Painting

Transferable: CSU, UC; CSU-GE:C1; GAV-GE:C1

Studio practice in the design, methods and materials of mural painting through the production of individual and collaborative murals. The course will also provide a historical survey of mural painting, from pre-historic cave painting to contemporary urban murals, with particular focus on the muralists of Mexico. May be repeated three times for credit. This course has the option of a letter grade or pass/no pass.

10471 L/L AR102 Rosette A 4.3 3.0 F 0900-0105
ARR TBA 2.3

ART 15A Beginning Painting: Form and Composition

Transferable: CSU, UC; GAV-GE:C1

This is an introductory painting course. Students will study traditional, contemporary and experimental painting techniques using acrylics and/or oils as the primary media. Emphasis will be placed on foundational concepts and approaches including color, form and composition. May be repeated once for credit. This course has the option of a letter grade or pass/no pass. ADVISORY: Art 2A or 3A, or portfolio review of student's work.

10472 L/L AR102 Webster E 6.6 3.0 TR 1120-0225

ART 15B Beginning Painting: Imagination and Expression

Transferable: CSU, UC; GAV-GE:C1

This is an introductory painting course. Students will study traditional, contemporary and experimental painting techniques and media. Social, cultural and historical awareness are integrated with classroom explorations of expressive painting. Students develop a variety of painting approaches and a greater understanding of personal expression. May be repeated once for credit. This course has the option of a letter grade or pass/no pass. ADVISORY: Art 2A or Art 3A or Portfolio Review

10473 L/L AR102 Webster E 6.6 3.0 TR 1120-0225

ART 21 Ancient Americas: A History through Art

Transferable: CSU, UC; CSU-GE:C1, C2, IGETC:3A; GAV-GE:C2, F

A critical survey of history through the arts of pre-Columbian natives of North, Central and South America. The course will cover major societies and events from the appearance of major civilizations through the initial colonization efforts of European nations. Due to the distinct history of the Americas, this course uses the arts - architecture, sculpture, ceramics and painting, among others - of ancient societies as a primary source material. This course has the option of a letter grade or pass/no pass. This course is also listed as HIST 21. ADVISORY: Eligible for English 250.

10479 Lec HOL5 STAFFS 3.2 3.0 MW 0230-0350
Above class meets at the Hollister Briggs site.

ART 22 Field Work and Service

Transferable: CSU

Supervised field work within the college and with local agencies. Students serve in useful group activities in leadership roles prescribed for them by faculty or community agencies. A maximum of six units may be completed. This is a pass/no pass course. REQUIRED: Learning contracts must be filled out and signed by the student and the supervising instructor.

10482 Fld Ex Edberg J 1.0
10487 Fld Ex AR101 Gonzales K 1.0
10493 Fld Ex Rosette A 1.0
10495 Fld Ex AR101 Rekedal J 1.0

ART 10A/B CERAMICS



Play Dirty!
Hands-on studion work with historical and contemporary approaches.

Art 10A # 10462 MW 8:10-11:15 am Art 10B # 10468 TTh 6:00-9:05pm
10464 MW 11:20 am-2:25 pm
10467 TTh 6:00-9:05 pm

GET INVOLVED!

Help paint murals in your own community!

ART 14 Beginning Mural Painting



This class offers studio practice in the design, methods and production of individual and collaborative murals and a historical survey of mural painting.

Satisfies CSU General Education (Area C-1) and the ARTS Gavilan College graduation requirement (AREA C-1)

ART 21 Ancient America: A History Through Art

ART 21 Satisfies the CSU Humanities requirement (AREA C-2) and the UC/CSU ARTS requirement under the IGETC pattern.



Also listed as History 21

GoPrint You can now use the GoPrint system to print documents at all of Gavilan College's computer labs. No need to fumble around with coins! With your GoPrint or ASB card, you're good to go. See ad on page 8.

CRN Type Room Instructor Hrs. Units Days Begin-End

ART 23 Independent Study

Transferable: CSU

Designed to afford selected students specialized opportunities for exploring areas at the independent study level. The courses may involve extensive library work, research in the community, or special projects. May be repeated until six units of credit are accrued. This course has the option of a letter grade or pass/no pass. REQUIRED: The study outline prepared by the student and the instructor must be filed with the department and the dean.

10497	Ind	AR104	Edberg J	1.0				
10501	Ind	AR110	Rekedal J	1.0				
10503	Ind	AR109	Rosette A	1.0				
10500	Ind	AR104	Edberg J	2.0				
10502	Ind	AR110	Rekedal J	2.0				
10504	Ind	AR109	Rosette A	2.0				
10505	Ind	AR110	Gonzales K	2.0				

ART 25A Art Methods

Transferable: CSU; CSU-GE:C1; GAV-GE:C1

Art methods and learning theory for those planning to work with preschool, elementary and secondary school students. Includes art therapy as well as gifted and special learner projects. Two dimensional work in printing, drawing, collage. Also listed as CD 25A.

10509	L/L	HOL1	McGinnis R	4.3	3.0	F	0400-0805	
	ARR		TBA	2.0				
Above class meets at the Hollister Briggs site.								
10511	L/L	AR103	Webster E	4.3	3.0	F	0900-0105	
	ARR		TBA	2.0				

ART 25B Art Methods

Transferable: CSU; GAV-GE:C1

Art methods, creativity and learning theory for those planning to work with preschool, elementary, and secondary school students. Includes art therapy as well as gifted and special learner projects. Three dimensional work in sculpture, bas relief, mobiles, paper mache', plaster, and various 3-D materials. Also listed as CD 25B.

10516	L/L	AR103	Webster E	4.3	3.0	F	0900-0105	
	ARR		TBA	2.0				
10512	L/L	HOL1	McGinnis R	4.3	3.0	F	0400-0805	
	ARR		TBA	2.0				
Above class meets at the Hollister Briggs site.								

ART 34A Life Drawing

Transferable: CSU, UC; GAV-GE:C1; CAN:ART24

Fundamentals of anatomy and representation of the human figure. Drawing from life. May be repeated once for credit. This course has the option of a letter grade or pass/no pass. ADVISORY: Art 34A or review of student's portfolio.

10522	L/L	AR102	Adkins J	6.3	3.0	F	0130-0535	
	ARR		TBA	2.0				

ART 34B Life Drawing

Transferable: CSU, UC; GAV-GE:C1

Further studies of the fundamentals of anatomy and representation of the human figure. Emphasis is placed on personal expression; abstract and experimental processes. May be repeated once for credit. This course has the option of a letter grade or pass/no pass. ADVISORY: Art 34A or review of student's portfolio.

10524	L/L	AR102	Adkins J	4.3	3.0	F	0130-0535	
-------	-----	-------	----------	-----	-----	---	-----------	--

ART 40 Art Gallery Assistance

Transferable: CSU; GAV-GE:C1

Individualized course in art gallery exhibition techniques and procedures. Students assist in design, installation, publicity, cataloguing and removal of exhibitions in the college gallery. May be taken until 4 units are accrued.

10534	Fld Ex	AR102	Webster E	1.0				
-------	--------	-------	-----------	-----	--	--	--	--

CRN Type Room Instructor Hrs. Units Days Begin-End

ART 74 Advanced Photoshop

Transferable: CSU; GAV-GE:C1

This course is for the PhotoShop-experienced student and explores PhotoShop's advanced features in depth. Students work on projects, which challenge their creativity and technical ability, and will be encouraged to develop complex projects for the web and for the printed page. May be repeated three times for credit. This course has the option of a letter grade or pass/no pass. This course is also listed as CSIS 74 and DM 74. ADVISORY: CSIS 75 PhotoShop I

10320	Lec	MHG5	Grzan R	3.3	3.0	R	0630-0935	
Above class meets at Morgan Hill Community site.								

ART 75 PhotoShop I

Transferable: CSU; GAV-GE:C1

This course is based on the software Adobe PhotoShop. Students learn to scan photographs and manipulate them using PhotoShop tool box and special effects filters. They will learn to color correct photos; mask image using channels; create duotone, tritone, and quadtone images; prepare photos for use in printing and on the web. This course has the option of a letter grade or pass/no pass. May be repeated three times for credit. ADVISORY: CSIS 124 (Windows Fundamentals), CSIS 2L

10904	L/L	LI128	Powers K	3.3	3.0	M	0330-0635	
10907	L/L	MHG5	Grzan R	3.3	3.0	T	0630-0935	
Above class meets at Morgan Hill Community site.								

ART 77 Introduction to Digital Media

Transferable: CSU, UC; GAV-GE:C1

An introduction to the field of digital media, including history, social impact, concepts, career options and industry trends. Applying learned visual and aural design principles, students will explore the use of computer-based tools in the design and production of digital media by creating and editing digital images, sounds, video, animation and text. A comprehensive term project for publication on the web or CD ROM will be required. This course is also listed as CSIS 77 and DM 77. This course has the option of a letter grade or pass/no pass. May be repeated twice for credit. ADVISORY: CSIS 124, CSIS 1, CSIS 2.2L, CSIS 3, or familiarity using the Macintosh or Windows operating systems.

10935	L/L	LI128	Beede R	3.2	3.0	TR	0945-1105	
10888	L/L	MHG5	Mullins A	3.3	3.0	W	0600-0905	
Above class meets at Morgan Hill Community site.								

ART 80 Digital Photography

Transferable: CSU, UC; GAV-GE:C1

The study of digital photography from digital camera to the computer-based printer or digital media. Artistic, theoretical, and technical aspects will be considered. Topics include information about types and purchasing of digital cameras; theory, mechanics, and art of digital imagery; digital darkroom; eccentricities of digital photo taking; stitching photos for virtual reality; and preparing digital images for print, World Wide Web and other digital media. This course has the option of a letter grade or pass/no pass. This course is also listed as DM 80 and CSIS 80. ADVISORY: CSIS 1 or CSIS 2/2L or ART 8A or equivalent computer experience.

10928	L/L	LI128	Edberg J	5.4	3.0	MW	1250-0315	
-------	-----	-------	----------	-----	-----	----	-----------	--

ART 85 Web Design I: Dreamweaver

Transferable: CSU; GAV-GE:C1

Basic and intermediate principles of designing Web pages/sites using the Dreamweaver web design software and HTML. Emphasis will be on good design and the use of tables, frames, forms, rollovers, DHTML, XHTML, behaviors, and CSS. Also includes site maintenance and the integration of multimedia components such as graphics, sound, animation, and video. This course is for the content person to design, develop, and maintain effective Web sites. This course is also listed as CSIS 85 and DM 85. This course has the option of a letter grade or pass/no pass. May be repeated twice for credit. ADVISORY: CSIS 6 or basic knowledge of HTML.

10333	ONLINE	Lawrence S	2.0					
10/14/09-12/18/09 You must have an email account to take this course. Start your course by going to www.gavilan.edu/disted . Unless you have made prior arrangements with the instructor, you MUST log on by 11:59 pm on the first day of the semester. Late adds must login within 24 hours of adding this course. If you miss the deadline you may be dropped. For help, contact your instructor or email disted@gavilan.edu .								

10908	Lec	HOL3	Lee K	3.3	2.0	M	0230-0535	
Above class meets at the Hollister Briggs site.								

CRN Type Room Instructor Hrs. Units Days Begin-End

ART 98 Special Topics: Materials in Art and Technology, Studio Build-in

Transferable: CSU; GAV-GE:C1

Special topics courses examine current problems or issues of interest to students within a specific discipline area. This is a studio art course that aims to teach students how to build, repair and arrange fixtures for a ceramic kiln and metal sculpture studio. We will use the newly floored area behind the Art Building as our case study. For transfer status, check with a counselor. This course may have the option of a letter grade or pass/no pass.

10947 Lec AR101 Hulin P 2.3 1.0 F 0900-1105

ART 107 Digital Media Design

Transferable: CSU; GAV-GE:C1

Fundamentals of design for visual, time-based, interactive, and sound arts as applied to digital media. Includes basic storytelling, graphic design, information architecture, and human factors. Page layout, scriptwriting, storyboards, and flow charts will be used as tools applicable to the design and development of business presentations, interactive media, educational multimedia, animation, web sites, video games, and film/video. This course has the option of a letter grade or pass/no pass. Also listed as CSIS 107 and DM 107. ADVISORY: CSIS 1 or CSIS 2/2L or equivalent computer experience

10943 L/L LI128 Fainshtein V 3.3 2.0 R 0330-0635

ART 108 Digital Media Lab

Transferable: CSU; GAV-GE:C1

Supervised practice and individualized computer assisted learning of software applications and techniques commonly found in the design and production of digital media (e.g., digital art and imaging, digital photography, digital print, digital audio/video, web design/authoring, DVD/CD ROMs, animation). Supplements lecture courses. Open entry/exit, so may be added at anytime during the semester. This is a pass/no pass course. May be repeated three times for credit. Also listed as DM 108 and CSIS 108. ADVISORY: CSIS 1 or CSIS 2/2L or equivalent computer experience.

10730 Lab LI128 Beede R .5

10760 Lab LI128 Beede R 1.0

ART 110 Interactive Animation: Flash

Transferable: CSU; GAV-GE:C1

The production of vector graphics, animation, and interactive multimedia in Shockwave-Flash format for web pages and other digital media. Design of highly interactive web site interfaces and animated games using Flash actions (scripting). Useful for web designers/developers, animators, and multimedia authors. This course has the option of a letter grade or pass/no pass. Also listed as CSIS 110 and DM 110. May be repeated three times for credit. ADVISORY: CSIS 1, CSIS 2/2L, CSIS 124 or basic computer knowledge.

10896 L/L LI128 Beede R 3.2 3.0 MW 1120-1240

ART 113 Introduction to Digital Video

Transferable: CSU; GAV-GE:C1

Introduction to the aesthetic and technical aspects of digital video recording, non-linear editing, special effect generation, and production of video (and associated audio) using the personal computer equipped with specialized software such as iMovie, Final Cut Pro, and After Effects. Also considered will be the preparation of digital video for use in interactive media such as CD, DVD, and the World Wide Web. Students will produce a final digital video project on DVD. This course has the option of a letter grade or pass/no pass. May be repeated two times for credit. Also listed as CSIS 113 and DM 113. ADVISORY: CSIS 1 or CSIS 2/2L or equivalent computer experience

10899 L/L LI128 Beede R 3.2 3.0 MW 0945-1105

Check out class offerings at our **Morgan Hill** and **Hollister** sites.

Hollister: See pages 60-61 Morgan Hill: See pages 62-63

We have now made it easier for you to find out what is happening at Gavilan College.



Log on to <http://www.gavilan.edu/pio/GavArts.html> to see what entertainment and events Gavilan has to offer!

CRN Type Room Instructor Hrs. Units Days Begin-End

ART 114 Digital Media Production

Transferable: CSU; GAV-GE:C1

A team oriented practicum that focuses on the application of learned skills to the production of digital media and digital print projects, such as web sites, CD ROM, and DVDs. Project development will be accomplished according to team derived master schedules. Lectures will be on project management, work coordination and production techniques, client-team interface, asset management and integration, budget estimate, testing, and copyright infringement. Please note that this is very much a team oriented class. This course has the option of a letter grade or pass/no pass. This course is also listed as CSIS 114 and DM 114. ADVISORY: At least one of the following: ART 75, GBUS 80, CGD 2, JOUR 18A, MUS 21, CSIS 7, CSIS 71 OR CSIS 77. or students must possess equivalent skills from any one of the following areas: digital media, computer graphics, digital print, journalism (publishing), film, TV/video, drawing or illustration, web design/development, business/marketing, or programming.

10945 Lec LI128 Beede R 3.2 2.0 TR 1120-1240

ART 140 Basic Digital Film/Video Production

Transferable: CSU, UC; GAV-GE:C1

An on-line self-paced course covering the basics of film/video production and post production (editing) using "easy to use" computer software such as Apple's iMovie. Beneficial for students who are producing a video/film project as a requirement for another college course, extra skills development, or for self interest. Completion of the associated class or personal project in DVD format using either personal video equipment or the equipment in the Digital Media Studio is required. May be repeated twice for credit. This course has the option of a letter grade or pass/no pass. This course is also listed as DM 140 and CSIS 140.

10902 ONLINE Beede R 1.0

You must have an email account to take this course. Start your course by going to www.gavilan.edu/disted. Unless you have made prior arrangements with the instructor, you MUST log on by 11:59 pm on the first day of the semester. Late adds must login within 24 hours of adding this course. If you miss the deadline you may be dropped. For help, contact your instructor or email disted@gavilan.edu.

CRN Type Room Instructor Hrs. Units Days Begin-End

ASTRONOMY

ASTR 1 Introduction to General Astronomy

Transferable: CSU, UC; CSU-GE:B1, IGETC:5A; GAV-GE:B1

An introduction to the realm of astronomy and space science. Topics to be covered include the historical development of astronomy, the physics of gravitation and radiation, the solar system, stellar astronomy, galactic and extragalactic astronomy, and cosmology. ADVISORY: Mathematics 205 and eligible for English 250 and English 260.

10278	Lec	PH103	Bumgarner J	3.3	3.0	T	0230-0535
10279	Lec	MHG3	Bumgarner J	3.3	3.0	T	0600-0905 Above class meets at Morgan Hill Community site.
10280	Lec	HOL1	Snyder J	3.3	3.0	T	0600-0905 Above class meets at the Hollister Briggs site.

Athletics: see Physical Education (PE)

AVIATION FLIGHT TECHNOLOGY

AFT 134 Aviation Flight Technology

Transferable: CSU

This course includes all aerodynamics, navigation, regulations, airport and airspace requirements, meteorology, and emergency procedures necessary to qualify for a private pilot certificate. ADVISORY: Completion of English 250 and English 260.

10925	Lec	PB4A	Jackson C	3.3	3.0	T	0600-0905
-------	-----	------	-----------	-----	-----	---	-----------

AVIATION MAINTENANCE TECHNOLOGY

Classes begin early: Check start dates below.

AMT 100 General Aircraft Technology

Transferable: CSU

This course will provide the student with a thorough understanding of the use of basic hand tools and measuring devices, aircraft hardware, materials, and processes, mathematics and physical science for aircraft, aircraft weight and balance, aircraft drawing and blueprint reading. Both theory and practical application to aircraft systems is taught. ADVISORY: Mathematics 205 Meets at Gavilan College Aviation Department, 490 Skylane Drive, Hollister Airport, Hollister. Basic hand tools required. Details at the first class meeting.

10801	L/L	AV102	Connal D	14.0	7.5	MTWRF	0800-1030 08/12/09 - 12/18/09 Above class meets at the Hollister Airport.
-------	-----	-------	----------	------	-----	-------	--

AMT 110 Airframe Maintenance Technology

Transferable: CSU

Study of aircraft aerodynamics, rigging and assembly, aircraft sheet metal structures and welding technology. Also the study of cabin atmosphere systems, fuel systems, and line maintenance, level information on aircraft instruments. Each of these areas will be accompanied with appropriate laboratory time. Meets at Gavilan College Aviation Department, 490 Skylane Drive, Hollister Airport, Hollister. Basic hand tools required. Details at the first class meeting.

10802	L/L	AV102	Hall C	25.0	13.5	MTWRF	1030-0330 08/12/09 - 12/18/09 Above class meets at the Hollister Airport.
-------	-----	-------	--------	------	------	-------	--

CRN Type Room Instructor Hrs. Units Days Begin-End

AMT 120 Aviation Powerplant Technology

Transferable: CSU

This course is part of the curriculum required by the Federal Aviation Administration to obtain certification as an aircraft powerplant maintenance technician. This certificate allows the rated technician to perform maintenance, preventive maintenance repairs and alterations to USA FAA certificated aircraft powerplants. This Section covers the theory and practical application of operation, overhaul practices, inspection, installation, testing and troubleshooting techniques covering the subject areas of reciprocating and turbine engines, ignition, induction, supercharging, cooling and exhaust systems. ADVISORY: Successful completion of AMT 101 and AMT 111. Basic hand tools required. Details at the first class meeting.

10803	L/L	AV102	TBA	27.2	14.0	TWRF	0830-0300 08/12/09 - 12/18/09 Above class meets at the Hollister Airport.
-------	-----	-------	-----	------	------	------	--

AMT 123 Independent Study

Transferable: CSU

Designed to afford selected students specialized opportunities for exploring areas at the independent study level. The courses may involve extensive library work, research in the community, or special projects. May be repeated until six units of credit are accrued. This course has the option of a letter grade or pass/no pass. REQUIRED: The study outline prepared by the student and the instructor must be filed with the department and the dean. Meets at Gavilan College Aviation Department, 490 Skylane Drive, Hollister Airport, Hollister.

10859	Ind	AV102	Flippen T		1.0		Above class meets at the Hollister Airport.
-------	-----	-------	-----------	--	-----	--	---

AMT 190 Occupational Work Experience/Aviation

Transferable: CSU

College credit for learning experience obtained on the job in accordance with a training plan developed cooperatively between the employer, college and student. 75 hours per semester per unit or 60 hours per semester for unpaid experience. This is a pass/no pass course. May be taken for a maximum of 16 units of work experience units. REQUIRED: Declared vocational major. Concurrent in seven or more units (including CWE units, except for summer school. For summer school, enrollment in one other class is required). Minimum 2.00 G.P.A. Meets at Gavilan College Aviation Department, 490 Skylane Drive, Hollister Airport, Hollister.

Mandatory course orientation for the following classed will be conducted Tuesday October 6, 2009 from 530 pm-630 pm the North/South Lounge, Wednesday, October 7, 2009 from 430 pm -530 pm in the North/South Lounge and Thursday October 8, 2009 from 8 am to 9 am in the North/South Lounge. Students need to attend one of the three meetings. Please contact Susan Sweeney, CWE Coordinator at (408) 848-4813 for more information.

10850	Wrk Ex	LI101A	Sweeney S		1.0		
10851	Wrk Ex	LI101A	Sweeney S		2.0		
10852	Wrk Ex	LI101A	Sweeney S		3.0		
10853	Wrk Ex	LI101A	Sweeney S		4.0		

BIOLOGICAL SCIENCE

BIO 1 General Biology

Transferable: CSU, UC; CSU-GE:B2, B3, IGETC:5B; GAV-GE:B2, B3; CAN:BIOL2, BIOL SEQ A

A general biology course with an emphasis on the structure and function of cells, cell respiration, photosynthesis, cell cycle, Mendelian and non-classical genetics, evolution and diversity of life. The course is required for students majoring in biology and/or its subcategories (e.g., plant or animal sciences). PREREQUISITE: Biological Science 10 with a grade of 'C' or better and Mathematics 233 with a grade of 'C' or better. ADVISORY: Chemistry 30A; eligible for English 250 and English 260.

10281	Lec	LS102	Morales R	3.2	4.0	TR	0230-0350
	Lab	LS102	Morales R	3.3		F	0810-1115

BIO 4 General Zoology

Transferable: CSU, UC; CSU-GE:B2, B3, IGETC:5B; GAV-GE:B2, B3; CAN:BIOL4, BIOL SEQ A

The classification, ecology, evolution and systems analysis of biological functions in major taxonomic groups of animals from Protists through to Chordata. PREREQUISITE: Mathematics 233 with a grade of 'C' or better. ADVISORY: Eligible for English 250 and English 260.

10324	Lec	LS102	Morales R	3.2	4.0	TR	0945-1105
	Lab	LS103	Morales R	3.3		M	0230-0535

Campus under construction
ROOM NUMBERS MAY CHANGE!

Check room numbers online before your first class.

Classroom Locations: Refer to "How to Use This Schedule" on page 5.

CRN Type Room Instructor Hrs. Units Days Begin-End

BIO 7 Human Anatomy

Transferable: CSU, UC; CSU-GE:B2, B3, IGETC:5B; GAV-GE:B2, B3; CAN:BIOL10, BIOL SEQ B
A functional approach to the gross and microscopic structure of the major systems of the human body. Includes dissection in lab. A cadaver is observed in this course. **PREREQUISITE:** Biological Science 10 or 15 with a grade of credit or C or better. **ADVISORY:** Eligible for English 250, English 260 and Mathematics 205.

10325	L/L	LS103	Maldini D	8.6	4.0	TR	0945-0150
10326	L/L	LS103	Robinson T	4.0	4.0	S	0800-1200
	L/L	LS103	Robinson T	4.5		S	0100-0515

BIO 8 General Microbiology

Transferable: CSU, UC; CSU-GE:B2, B3, IGETC:5B; GAV-GE:B2, B3; CAN:BIOL14
An introduction to microbiology with an emphasis on bacteriology. Includes the study of morphology, physiology and classification of microorganisms, a survey of infectious disease, immunology and techniques for culture and control of microorganisms. This course is also listed as Allied Health 8. **PREREQUISITE:** Biological Science 10 or 15 with a grade of credit or C or better. **ADVISORY:** Chemistry 30A; eligible for English 250, English 260 and Mathematics 205.

10345	Lec	LS101	McKenna M	4.6	5.0	WF	0945-1150
	Lab	LS103	McKenna M	3.2		WF	0810-0930

If this class is full please contact lecture instructor by email to be added to wait list.

10346	Lec	LS101	McKenna M	4.6	5.0	WF	0945-1150
	Lab	LS103	McKenna M	3.2		WF	1250-0210

If this class is full please contact lecture instructor by email to be added to wait list.

BIO 9 Human Physiology

Transferable: CSU, UC; CSU-GE:B2, B3, IGETC:5B; GAV-GE:B2, B3; CAN:BIOL12, BIOL SEQ B
A study of the functions of the major organs and organ systems of the human body, emphasizing control at the cellular level, integration of systems and homeostasis of the human body. This course is also listed as Allied Health 9. **PREREQUISITE:** Biological Science 7 or 15 with a grade of credit or C or better. **ADVISORY:** Chemistry 30A; eligible for English 250, English 260 and Mathematics 205.

10348	Lec	LS101	Richardson A	4.3	5.0	W	0550-0955
	Lab	LS103	Richardson A	3.3		M	0600-0905
10990	Lec	LS101	Richardson A	4.3	5.0	W	0550-0955
	Lab	LS103	Smith M	3.3		R	0400-0700

BIO 10 Principles of Biology

Transferable: CSU, UC; CSU-GE:B2, B3, IGETC:5B; GAV-GE:B2, B3
An introductory biology course covering functions at the cellular and organismal levels. Includes study of the basic principles of metabolism, heredity, evolution and ecology. Primarily for non-biological science majors. **ADVISORY:** Eligible for English 250, English 260 and Mathematics 205.

10284	Lec	LS101	Crocker J	3.2	4.0	TR	0810-0930
	Lab	LS102	Crocker J	2.3		M	0810-1015
10286	Lec	LS101	Crocker J	3.2	4.0	TR	0810-0930
	Lab	LS102	Crocker J	2.3		W	0810-1015
10290	Lec	SS210	Keys S	3.2	4.0	MW	0230-0350
	Lab	LS102	Keys S	2.3		M	1120-0125
10291	Lec	SS210	Keys S	3.2	4.0	MW	0230-0350
	Lab	LS102	Keys S	2.3		W	1120-0125
10294	Lec	SS210	Keys S	3.2	4.0	MW	0230-0350
	Lab	LS102	Keys S	2.3		W	0400-0605
10296	Lec	SS210	Keys S	3.2	4.0	MW	0230-0350
	Lab	LS102	Keys S	2.3		M	0400-0605
10282	L/L	LS102	Gemar A	4.6	4.0	MW	0630-0835

The Sky is the Limit!

at the **Gavilan Aviation Maintenance Technology Program**



Unlimited employment opportunities
Graduates can earn up to \$30/hour
Internships available
Accredited by the Federal Aviation Administration
Receive both Airframe and Powerplant Licenses in 4 semesters
Fast and easy commute to training program

For complete program information please contact the Aviation Department at the Hollister Airport (831) 637-1151 or the Technical and Public Services Division at Gavilan (408) 848-4719.

Join the Concert Choir!

MUS 13

CRN 40740
Tuesdays 6:00 - 9:05 pm
with Phil Robb
Meets at Gilroy High School



Brush Up your Software Skills

Most Computer Applications classes are repeatable.

New! Liberal Arts Associate's Degree Areas of Emphasis

Check out the updated Catalog online - www.gavilan.edu/catalog
- click on Liberal Arts.

CRN Type Room Instructor Hrs. Units Days Begin-End

BIO 15 Survey of Human Anatomy and Physiology

Transferable: CSU, UC; CSU-GE:B2, B3, IGETC:5B; GAV-GE:B2, B3

An introductory study of the structure and function of the human body. Includes study at the cellular and organ system levels, emphasizing integration of systems. Note that a cadaver will be observed in this course. This course is also listed as Allied Health 15. ADVISORY: Biological Science 10, Eligible for English 250, English 260 and Mathematics 205. Course will include the viewing of a cadaver.

10302	Lec	ONLINE	STAFFS	5.0			
	Lab	LS103	STAFFS	3.3	W		0400-0705

This Hybrid class will be delivered partially online and also meet face to face at select locations. You must have an email account to take a distance ed course. Unless you have made prior arrangements with the instructor, come to class in person on the first day of the semester or the first day of class for short-term courses. If you do not show up on the first day you may be dropped. For help, contact your instructor or email disted@gavilan.edu.

10323	L/L	LS103	Kim L	8.0	5.0	TR	0700-1000
-------	-----	-------	-------	-----	-----	----	-----------

Beauty School: see Cosmetology

BIOTECHNOLOGY

BIOT 103 Biotechnology Lab Skills and Instrumentation

Transferable: CSU

Introduction to biotechnology laboratory skills. Techniques will include measuring, aseptic technique and transfer skills, preparation of buffers and other solutions, basic media preparation and dilutions, electrophoresis. Includes use and care of instruments such as microscope, spectrophotometer, centrifuge, pH meter, mechanical and micropipettes, autoclave, and electronic balance. Will also include keeping of a notebook, report writing and calculations. ADVISORY: Completion of any high school science course with a grade of 'C' or better; eligible for English 250; eligible for Math 205.

10349	L/L	LS102	Richardson A	8.6	4.0	TR	0530-0935
-------	-----	-------	--------------	-----	-----	----	-----------

Business Accounting: see Accounting

BUSINESS, GENERAL

BUS 1 Fundamentals of Business

Transferable: CSU, UC; GAV-GE:D2

This course introduces students to business and the array of opportunities that it offers. The course will help students recognize careers that will be of interest to them with consideration of their own skills and aptitudes. Different facets of business will be covered and students will learn about establishing their own business. This course has the option of a letter grade or pass/no pass. Previously listed as GBUS 1. ADVISORY: Eligible for English 250 and English 260.

10194	Lec	PB13	McCormick D	3.2	3.0	MW	0945-1105
-------	-----	------	-------------	-----	-----	----	-----------

10193	Lec	PB13	McCormick D	3.2	3.0	MW	1120-1240
-------	-----	------	-------------	-----	-----	----	-----------

10204	Lec	MHG12	Kurtz S	3.3	3.0	M	0600-0905
-------	-----	-------	---------	-----	-----	---	-----------

Above class meets at Morgan Hill Community site.

BUS 80 Business Law

Transferable: CSU, UC; CAN:BUS12

Introduction to the law applicable to business institutions and their operations; social forces and their effect upon the development of law; sources of law, agencies for enforcement, and court procedure and administration agencies. Substantive law, that law which includes rights and duties, will include contracts, agency employment relationships, torts and crimes. This course has the option of a letter grade or pass/no pass. Previously listed as GBUS 80. ADVISORY: Eligible for English 250 and English 260.

10212	Lec	SS205	Banks S	3.3	3.0	T	0600-0905
-------	-----	-------	---------	-----	-----	---	-----------

CRN Type Room Instructor Hrs. Units Days Begin-End

BUSINESS OFFICE TECHNOLOGY

BOT 112 Business Computations with Machines

Transferable: CSU

Self-paced course in the operation of the electronic printing calculator. This course provides theory and practice in business applications with emphasis on mathematical problem solving. This course has the option of a letter grade or pass/no pass. May be repeated three times for credit. ADVISORY: Eligible for Mathematics 402.

10178	Lab	PB3	Gaffney S	.5			
-------	-----	-----	-----------	----	--	--	--

Orientation required. Schedule available in PB 3 (Business Skills Lab) Open-Entry/Open-Exit Class

BOT 180 Medical Terminology for the Office

Transferable: CSU

This course introduces fundamentals of medical word building used in the health profession (prefixes, word roots, suffixes and abbreviations) as well as review of body systems, with emphasis on analysis, definition, spelling and pronunciation. This course had the option of a letter grade or pass/no pass. ADVISORY: Eligible for English 250 and English 260.

10181	Lec	HOL6	Hardcastle C	3.0	3.0	M	0945-1240
-------	-----	------	--------------	-----	-----	---	-----------

Above class meets at the Hollister Briggs site.

10185	Lec	MHG4	Knapp D	3.0	3.0	W	0300-0555
-------	-----	------	---------	-----	-----	---	-----------

Above class meets at Morgan Hill Community site. ROP course.

BOT 181 Medical Billing - MediSoft

Transferable: CSU

This course in computerized billing procedures for a medical office uses MediSoft software. Students will learn the patient billing features of this software and complete a capstone simulation giving them hands-on realistic medical front office practice. This course has the option of a letter grade or pass/no pass. May be repeated three times for credit. ADVISORY: Eligible for English 250. Some computer experience.

10191	L/L	PB3	Knapp D	3.3	2.0	M	0600-0905
-------	-----	-----	---------	-----	-----	---	-----------

ROP course.

BOT 183 Medical Coding

Transferable: CSU

This course will introduce the student to the theory and procedure of coding for medical diagnoses, an increasingly essential and specialized healthcare communication system. The course is not a certification course. CPT coding is covered, with an overview of ICD-9 coding. This course has the option of a letter grade or pass/no pass. May be repeated three times for credit. ADVISORY: BOT 180.

10192	Lec	PB3	Knapp D	3.3	2.0	R	0600-0905
-------	-----	-----	---------	-----	-----	---	-----------

ROP course.

Ceramics: see Art

CHEMISTRY

CHEM 1A General Chemistry

Transferable: CSU, UC; CSU-GE:B1, B3, IGETC:5A; GAV-GE:B1, B3; CAN:CHEM2, CHEM SEQ A

This is the first semester of a year-long general chemistry course designed for science, engineering and pre-professional majors. Topics include properties of matter, atomic structure, the Periodic Table, stoichiometry, elements and compounds, bonding, molecular structure, chemical reactions, states of matter, as well as the properties of gases and solutions. PREREQUISITE: Chemistry 30A with a grade of 'C' or better, or high school chemistry with a grade of 'B' or better completed within the last five years, and Mathematics 233 with a grade of 'C' or better. ADVISORY: Eligible for English 250 and English 260.

10355	Lec	CH105	Clark D	4.2	5.0	MWF	0945-1055
	Lab	CH101	Clark D	3.2		R	0945-1249

10356	Lec	CH105	Clark D	4.2	5.0	MWF	0945-1055
	Lab	CH101	Ndreu D	3.3		R	0600-0905

CRN Type Room Instructor Hrs. Units Days Begin-End

CHEM 12A Organic Chemistry

Transferable: CSU, UC; CSU-GE:B1, B3, IGETC:5A; GAV-GE:B1, B3

This is the first semester of a year-long organic chemistry course designed for chemistry majors, pre-professional medical, biology, and science majors. Topics include nomenclature, stereochemistry, mechanisms, reactions and spectroscopic studies of organic compounds. Lecture and laboratory methods will focus on synthesis, isolation, purification, elucidation, and identification of organic structures, as well as instrumental methods and data interpretation. PREREQUISITE: Chemistry 1B

10351	Lec	LS102	Clark D	3.2	5.0	TR	1250-0210
	Lab	CH101	Clark D	6.6		TR	0230-0535

CHEM 23 Independent Study

Transferable: CSU

Designed to afford selected students specialized opportunities for exploring areas at the independent study level. The courses may involve extensive library work, research in the community, or special projects. May be repeated until six units of credit are accrued. This course has the option of a letter grade or pass/no pass. REQUIRED: The study outline prepared by the student and the instructor must be filled with the department and the dean.

10357	ARR	CH105	Clark D		2.0		
-------	-----	-------	---------	--	-----	--	--

CHEM 30A Elementary Chemistry

Transferable: CSU, UC; CSU-GE:B1, B3, IGETC:5A; GAV-GE:B1, B3; CAN:CHEM6, CHEM SEQ B

This is a first semester college chemistry course designed for majors preparing to take Chemistry 1A, nursing and allied health students, as well as general education. The course will cover the principles of chemistry including properties of matter, energy, atomic theory, the Periodic Table, stoichiometry, elements and compounds, the properties of bonding, molecular structure, chemical reactions, states of matter, acidity, solutions and gases, as well as an introductory to organic chemistry. ADVISORY: Mathematics 205; eligible for English 250 and English 260.

10358	Lec	CH105	Clark D	3.2	4.0	MW	0810-0930
	Lab	CH101	Clark D	3.2		T	0945-1249
10359	Lec	CH105	Clark D	3.2	4.0	MW	0810-0930
	Lab	CH101	Ndreu D	3.3		T	0600-0905

CHILD DEVELOPMENT

CD 1 Principles & Philosophies of Early Childhood Education

Transferable: CSU

An overview of current educational theories and research, as well as an historical perspective on the development of early childhood education. Observations in schools are to be arranged. ADVISORY: Eligible for English 250 and English 260.

10491	Lec	MHG4	Clabaugh D	3.2	3.0	TR	1250-0210
Above class meets at Morgan Hill Community site.							

10494	Lec	SS203	Staff	3.3	3.0	T	0600-0905
This class is taught in Spanish. (Esta clase se enseña en Español).							

CD 2 Early Child Development

Transferable: CSU, UC; CSU-GE:D9, E, IGETC:4; GAV-GE:D2

A systematic study of the child from prenatal life through the preschool years. The course integrates the basic concepts of physical, cognitive and psychosocial development at each major stage of life during this period. This course is also listed as PSYC 2. This course has the option of a letter grade or pass/no pass. ADVISORY: Eligible for English 250 and English 260; transfer students consult with advisor.

10597	Lec	MHG4	Bumgarner M	3.2	3.0	MW	0945-1105
Above class meets at Morgan Hill Community site.							

10964	Lec	GHS-B1	Weiler J	3.3	3.0	T	0330-0630
This class is part of the High Step Program. It will be offered at Gilroy High School, room B-1. This class is open to all students. For more information, see a Gavilan counselor.							

10601	Lec	HOL5	Muscari D	3.3	3.0	M	0600-0905
Above class meets at the Hollister Briggs site.							

10604		ONLINE	Bumgarner M		3.0		
You must have an email account to take this course. Start your course by going to www.gavilan.edu/disted . Unless you have made prior arrangements with the instructor, you MUST log on by 11:59 pm on the first day of the semester. Late adds must login within 24 hours of adding this course. If you miss the deadline you may be dropped. For help, contact your instructor or email disted@gavilan.edu .							



Train for a Career in Biotechnology

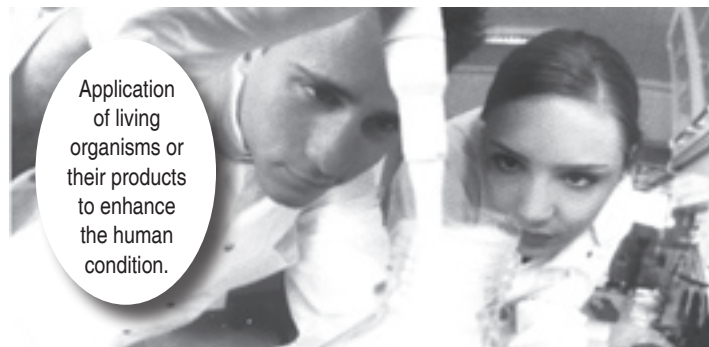

Application of living organisms or their products to enhance the human condition.

In addition to the biotechnology industry, jobs for lab technicians can be found in:

- Environmental testing
- Forensics
- Hospitals
- Plant pathology
- Research

Offered this semester

BIOT 103
Biotechnology Lab Skills and Instrumentation

www.gavilan-sjbc.org

Certificate of Proficiency in Biotechnology (17 units)

BIOT 103	Biotechnology Lab Skills and Instrumentation (4 units)
BIOT 104	Seminar in Biotechnology (1 unit)
BIO 10	Principles of Biology (4 units)
CHEM 30A	Elementary Chemistry (4 units)
CHEM 30B	Elementary Organic and Biochemistry (4 units)



Begin your year of Organic or General Chemistry here at Gavilan College!

CHEM 1A General Chemistry

The first semester of a year-long General Chemistry course designed for science, engineering and pre-professional majors.

Chem 1A is a prerequisite for Chem 1B (taught in the spring semester)

CHEM 12A Organic Chemistry

The first semester of a year-long Organic Chemistry course designed for science, engineering and pre-professional majors.

Chem 12A is a prerequisite for Chem 12B (taught in the spring semester)

The above two courses satisfy Science major prerequisites and the Physical Science requirement for transfer to both the California State University and the University of California systems.

CHEM 30A Elementary Chemistry

The first semester chemistry course designed for majors preparing to take Chemistry 1A, nursing and allied health students, as well as general education.

Chem 30A is a prerequisite for Chem 30B (taught in the spring semester)

CHEM 30A satisfies the Physical Science requirement for transfer to both the California State University and the University of California systems. It may satisfy Science major prerequisites. See a counselor.

Instructor for all courses: Dr. Dale Clark

All of the above courses satisfy Science major prerequisites and the Physical Science requirement for transfer to both the California State University and the University of California systems.

CRN Type Room Instructor Hrs. Units Days Begin-End

CD 3 Child Growth and Development During the School Years

Transferable: CSU, UC; CSU-GE:D9, E, IGETC:4I; GAV-GE:D2

Continuation of the study of the principles of child development with emphasis on children from six years through adolescence. Includes developmental theories and topics relevant to these ages. This course is also listed as PSYC 3. This course has the option of a letter grade or pass/no pass. ADVISORY: Eligible for English 250 and English 260; Child Development 2; transfer students consult with advisor.

10449 Lec MHG4 Bumgarner M 3.2 3.0 MW 1120-1240
Above class meets at Morgan Hill Community site.

10966 Lec GHS-B6 O'Leary M 3.0 3.0 T 0330-0630
This class is part of the High Step Program. It will be offered at Gilroy High School, room B-6. This class is open to all students. For more information, see a Gavilan counselor.

10465 ONLINE Bumgarner M 3.0
You must have an email account to take this course. Start your course by going to www.gavilan.edu/disted. Unless you have made prior arrangements with the instructor, you MUST log on by 11:59 pm on the first day of the semester. Late adds must login within 24 hours of adding this course. If you miss the deadline you may be dropped. For help, contact your instructor or email disted@gavilan.edu.

CD 4 Observing and Assessing Children

Transferable: CSU

Provides training in a variety of naturalistic and formal observation techniques, and discusses the use of standardized testing in children. Students learn to use formal observation tools, make a case study portfolio and give a parent conference. Observing children in classroom settings is required. This course has the option of a letter grade or pass/no pass. ADVISORY: Eligible for English 250 and English 260 and completion of CD2.

10484 Lec LS106 O'Leary M 3.0 3.0 TR 0810-0925

CD 5 Child/Family and Community/El Niño, la Familia y la Comunidad

Transferable: CSU / Transferible: CSU

Patterns of child-rearing in contemporary society. Interaction of family, school and community. Significance of personal and social values in family life and community action. Individual and social resources for family life including health, welfare and improving child development. ADVISORY: Eligible for English 250 and English 260. / *Las muestras de cuidar niños en nuestra sociedad contemporánea. La interacción de la familia, la escuela y la comunidad. El significado de valores personales y sociales en la acción de la vida doméstica y la comunidad. El individuo y los recursos sociales para la vida doméstica inclusive la salud, el bienestar y mejorar desarrollo del niño. Recomendable: Elegible para inglés 250 e inglés 260.*

10485 Lec MHG4 Clabaugh D 3.2 3.0 TR 1045-1205
Above class meets at Morgan Hill Community site. This class is part of a Learning Community if you enroll you must also enroll in ENGL 250, CRN 10149 or 10150. See ad on page 79.

10488 Lec PB5 Staff 3.3 3.0 R 0600-0905
This class is taught in Spanish. (Esta clase se enseña en Español).

CD 7 Cultural Context of Child & Family in a Diverse Society

Transferable: CSU; CSU-GE:D7; GAV-GE:D2, F

Examines cultural influences on child-rearing practices, family values, and human development. Perspectives from the social sciences will be used to critique and review theoretical and practical implications of oppression and privilege as they apply to families, schools, and communities, including historical and socio-cultural factors. The processes of socialization and identity development, and the importance of respectful, reciprocal relationships that support and empower families. Self-examination and reflection on issues related to social identity, stereotypes and bias, social and educational access, media and schooling. Also listed as PSYC 7 and ANTH 9. ADVISORY: Eligible for English 250 and English 260.

10866 ONLINE Bumgarner M 2.0
You must have an email account to take this course. Start your course by going to www.gavilan.edu/disted. Unless you have made prior arrangements with the instructor, you MUST log on by 11:59 pm on the first day of the semester. Late adds must login within 24 hours of adding this course. If you miss the deadline you may be dropped. For help, contact your instructor or email disted@gavilan.edu.

CRN Type Room Instructor Hrs. Units Days Begin-End

CD 9 Child Health/Nutrition and Safety

Transferable: CSU

Health, Safety and Nutrition promotion in young children is studied. Course covers illness and accident prevention, quality food programs and community resources for health, safety and nutrition. Students will learn to promote making healthier choices by teaching hygiene, safety practices and nutritious food choices. Poison prevention, fire and earthquake safety and emergency preparedness is covered. Students learn to design lesson plans to teach children and their parents to make healthy, safe and nutritious choices. This course has the option of a letter grade or pass/no pass. ADVISORY: Eligible for English 250 and English 260.

10489 Lec LS106 Alonzo S 3.3 3.0 M 0600-0905

CD 10 Children with Special Needs

Transferable: CSU

An introductory course in special education, which includes a survey of special needs such as learning disabilities, emotional disturbances, developmental delays, physical limitations, cognitive differences, and giftedness. Students will study the history of special education and legislation in the USA, ethical assessment and family-based intervention techniques, diversity and family issues, advocacy for special needs children, and the use of technology in special education environments. This course has the option of a letter grade or pass/no pass. ADVISORY: Eligible for English 250 and English 260. Completion of CD 2.

10863 Lec LS106 O'Leary M 3.2 3.0 TR 1120-1240

CD 11A Administration of Programs for Young Children

Transferable: CSU

The principles and practices of the organization and administration of facilities for preschool aged children. Areas covered include organizational structure, budgeting, personnel policies and practices, records, statistics, reporting, relationship with community resources, regulatory agencies, and parents. ADVISORY: Child Development 1 and 2.

10496 Lec LS106 Alonzo S 3.3 3.0 W 0600-0905

CD 13 Infant and Toddler Development and Care

Transferable: CSU

Students will study the developmental stages of growth specific to infants and toddlers and learn how to foster positive techniques for nurturing infants and toddlers in group settings. Students will study the RIE philosophy and learn how to observe children in child care and home day care settings. This course has the option of a letter grade or pass/no pass. ADVISORY: Eligible for English 250 and English 260. Child Development 2.

10589 Lec LS106 Weiler J 3.2 3.0 MW 1250-0210

CD 14A Working with School Age Children

Transferable: CSU

Students will learn the developmental characteristics of school aged children, issues relating to before and after school programs for children from kindergarten to grade eight, and specific details of administering and leading such a program. Other topics include recreation versus academic enrichment, staffing requirements, age groupings, program content, and community resources. This course has the option of a letter grade or pass/no pass. ADVISORY: Eligible for English 250 and 260. Child Development 3.

10590 Lec MHG11 Hoshiko M 3.3 3.0 W 0630-0935
Above class meets at Morgan Hill Community site.

CD 20 Children's Language and Literature

Transferable: CSU

A developmental view of children's language and literacy learning in a framework of children's literature. Students will be presented with steps in children's literacy learning in order to help them organize classrooms and plan activities to support the growth of writing and reading. Students will study historical trends in children's literature and participate in practical experiences and activities that use a wide range of techniques and materials for advancing language comprehension and usage. This course has the option of a letter grade or pass/no pass. ADVISORY: Eligible for English 250 and English 260.

10603 Lec MHG4 Malaspina B 3.3 3.0 R 0600-0905
Above class meets at Morgan Hill Community site.

Be Aware If your goal is a MULTIPLE SUBJECT CREDENTIAL, you may need MATH 12, Math for Elementary Teachers.

Classroom Locations: Refer to "How to Use This Schedule" on page 5.

CRN Type Room Instructor Hrs. Units Days Begin-End

CD 25A Art Methods

Transferable: CSU; CSU-GE:C1; GAV-GE:C1

Art methods and learning theory for those planning to work with preschool, elementary and secondary students. Includes art therapy as well as gifted and special learner projects. Two dimensional work in printing, painting, drawing, collage. Also listed as ART 25A.

10517	L/L ARR	AR103	Webster E TBA	4.3 2.0	3.0	F	0900-0105
-------	------------	-------	------------------	------------	-----	---	-----------

10514	L/L ARR	HOL1	McGinnis R TBA	4.3 2.0	3.0	F	0400-0805
-------	------------	------	-------------------	------------	-----	---	-----------

Above class meets at the Hollister Briggs site.

CD 25B Art Methods

Transferable: CSU; GAV-GE:C1

Art methods, creativity and learning theory for those planning to work with preschool, elementary, and secondary school students. Includes art therapy as well as gifted and special learner projects. Three dimensional work in sculpture, bas relief, mobiles, paper mache', plaster, and various 3-D materials. Also listed as ART 25B.

10518	L/L ARR	AR103	Webster E TBA	4.3 2.0	3.0	F	0900-0105
-------	------------	-------	------------------	------------	-----	---	-----------

10515	L/L ARR	HOL1	McGinnis R TBA	4.3 2.0	3.0	F	0400-0805
-------	------------	------	-------------------	------------	-----	---	-----------

Above class meets at the Hollister Briggs site.

CD 28A Child Dev & Guidance for Family Child Care/Foster Care

Transferable: CSU

An overview of the development of young children from pre-birth through age twelve, primarily designed for the family child care provider or foster parent. Students will be exposed to appropriate expectations and developmentally appropriate learning experiences for each stage of development. Six 3-hour sessions, or may be taught on three Saturdays. This course has the option of a letter grade or pass/no pass.

10455	Lec	MHG4	Henrickson P	3.6	1.0	T	0600-0920
-------	-----	------	--------------	-----	-----	---	-----------

09/01/09 - 09/29/09 Above class meets at Morgan Hill Community site.

CD 28B Dev Learning Activities for Family Child Care & Foster Care

Transferable: CSU

A practical curriculum development course for child care providers. The course includes a brief overview of children's learning processes and practical activities. Students will study appropriate curriculum for infants, toddlers, preschool, and school-age children in all areas of development. Students will learn how to set up a family child care environment. This course has the option of a letter grade or pass/no pass

10457	Lec	MHG4	Henrickson P	3.6	1.0	T	0600-0920
-------	-----	------	--------------	-----	-----	---	-----------

10/06/09 - 11/03/09 Above class meets at Morgan Hill Community site.

CD 28C Administering A Family Child Care Home

Transferable: CSU

Learning to establish and enforce contracts and policies, marketing your business, being professional in a caring profession, child abuse reporting requirements, licensing regulations for family child care, and the basics of record keeping techniques for family child care. Six 3-hour sessions, or may be taught on three Saturdays. This course has the option of a letter grade or pass/no pass.

10460	Lec	MHG4	Henrickson P	3.6	1.0	T	0600-0920
-------	-----	------	--------------	-----	-----	---	-----------

11/10/09 - 12/08/09 Above class meets at Morgan Hill Community site.

CD 30A Teaching Practices and Techniques

Transferable: CSU

Designing, developing and implementing contemporary curriculum and instructional methods for early childhood education. Completion of 30A and 30B satisfies the associate degree requirement for student teaching. ADVISORY: Completion of Child Development 1 and 2 with a "C" or higher. Concurrent enrollment in CD 190.

10876	Lec	CDC127	Staff	3.3	3.0	R	0600-0905
-------	-----	--------	-------	-----	-----	---	-----------



Nurturing Childhood:
in the family, school, and community

How does nurturance support learning and development in the home, school, and community?

Explore the theme of Nurturing Childhood in a dynamic, supportive learning environment.

Use writing, discussion, and discovery to identify nurturance as an important part of family life and community action.

CD 5 Early Child Development 3 units
10485 Lec MHG4 CLABAUGH D TuTh 1045A-1205P

Choose one of the following classes:

ENGL 250 Practical Writing 3 units
10149 L/L MHG4 SANDLER S TuTh 910A-1030A
MHG4 SANDLER S Tu 810A-900A

or

ENGL 250 Practical Writing 3 units
10150 L/L MHG4 SANDLER S TuTh 910A-1030A
MHG4 SANDLER S Th 810A-900A

CRN Type Room Instructor Hrs. Units Days Begin-End

CD 35 Establishing Positive Behavior in the Classroom

Transferable: CSU

Introduces the student to realistic and effective strategies for guiding all young children's behavior. This course demonstrates best practices for establishing and maintaining age and developmentally- appropriate productive behaviors among all children in a classroom setting. Course topics include environmental, developmental and special needs sources of maladaptive and challenging behaviors, guidelines for selecting and implementing strategies for positive behavior change for all children, and developing healthy communication strategies with families, program staff and children. ADVISORY: Eligible for English 1A.

10478	Lec	HU105	Clabaugh D	3.3	3.0	T	0600-0905
-------	-----	-------	------------	-----	-----	---	-----------

CD 97 Introduction to Service Learning with Children

Transferable: CSU

Service Learning is a method through which community participation, academic subjects, skills, and awareness are linked. Through a combination of community-based learning experiences, reading and writing assignments, and classroom-based learning experiences, this course seeks to foster the development of self-reflective, culturally aware and responsive community participants. Students will complete a minimum of 30 hours of community service work during the semester. This course has the option of a letter grade or pass/no pass.

10480	Lec	HOL1	Brown R	3.3	3.0	R	0600-0905
-------	-----	------	---------	-----	-----	---	-----------

Above class meets at the Hollister Briggs site.

CD 190 Occupational Work Experience/Child Development

Transferable: CSU

College credit for learning experience obtained on the job in accordance with a training plan developed cooperatively between the employer, college and student. 75 hours per semester per unit or 60 hours per semester for unpaid experience. This is a pass/no pass course. May be taken for a maximum of 16 work experience units. REQUIRED: Declared vocational major. Concurrent enrollment in seven or more units (including CWE units, except for summer school. For summer school, enrollment in one other class is required). Minimum 2.00 G.P.A.

For the four following classes: In order to obtain Field Work Credit for the Occupational Work Experience placement, students must enroll in CD30A or 30B.

10969	Wrk Ex	CD131	Staff	1.0			
10970	Wrk Ex	CD131	Staff	2.0			
10971	Wrk Ex	CD131	Staff	3.0			
10972	Wrk Ex	CD131	Staff	4.0			

CRN Type Room Instructor Hrs. Units Days Begin-End

CHINESE

CHN 1A Elementary Mandarin

Transferable: CSU

A comprehensive introduction to elementary Mandarin as a foreign language for students with no background in Mandarin. Emphasis is on listening, speaking and reading Mandarin as a medium of communication within a rich cultural framework, resulting in an active vocabulary of no less than 500 Chinese words and 100 phrases and idiomatic expressions. Writing and translation will be introduced. This course corresponds to one year of high school study. This course has the option of a letter grade or pass/no pass.

10854	Lec	SS205	Wenslaff X TBA	5.2 2.0	5.0	MTWR	0400-0505
-------	-----	-------	-------------------	------------	-----	------	-----------

COMMUNICATION STUDIES

CMUN 1A Introduction to Public Speaking

Transferable: CSU, UC; CSU-GE:A1, IGETC:1C; GAV-GE:A1; CAN:SPCH4

Basic principles of effective human communication and their function in contemporary public settings; emphasis is on the speech to inform, with special consideration given to fundamental communication skills, including organization, reasoning, explanation and listening. ADVISORY: Eligible for English 250 and English 260.

10580	Lec	HOL2	Andrade A	3.2	3.0	MW	0810-0930
Above class meets at the Hollister Briggs site.							
10560	Lec	MHG3	Cowan D	3.2	3.0	TR	0945-1105
Above class meets at Morgan Hill Community site.							
10562	Lec	PB1	Avila-Nores C	3.3	3.0	F	1215-0320
10586	Lec	PB1	Morella D	3.2	3.0	MW	1250-0210
10576	Lec	PB1	Besson D	3.2	3.0	TR	0230-0350
10584	Lec	PB1	Besson D	3.2	3.0	TR	0410-0530
10577	Lec	PB1	Giacalone S	3.3	3.0	W	0600-0905
10578	Lec	PB1	Besson D	3.3	3.0	R	0600-0905
10585	Lec	PB1	Besson D	3.3	3.0	T	0600-0905

CMUN 2 Oral Reading

Transferable: CSU, UC; CSU-GE:C1; GAV-GE:C1

An introduction to the analysis, preparation and dramatic reading of literature, including classical and contemporary prose, poetry and drama. Students will prepare, analyze and orally present and interpret great works of drama and literature for an audience. This course is also listed as THEA 4. ADVISORY: Eligible for English 250 and English 260.

10790	Lec	TH125	Lawton-Haehl J	3.2	3.0	TR	1120-1240
-------	-----	-------	----------------	-----	-----	----	-----------

CRN Type Room Instructor Hrs. Units Days Begin-End

CMUN 4 Intercultural Communication

Transferable: CSU, UC; CSU-GE:D3, D7, IGETC:4G; GAV-GE:D2, F

This course will explore the dynamics of communication as it applies to people from different cultures. Course content focuses on the application of theory and research to intercultural communication contexts. Increasing the awareness and understanding of diversity, the perception process, culture, verbal and non-verbal communication and the obstacles that prevent one from becoming a competent intercultural communicator will be examined.

10567	Lec	PB1	Giacalone S	3.2	3.0	MW	0400-0520
10571	Lec	PB1	Giacalone S	3.3	3.0	M	0600-0905

CMUN 5 Fundamentals of Communication Studies

Transferable: CSU, UC; CSU-GE:A1, IGETC:1C; GAV-GE:A1

This course provides instruction and application of theory and practice in various communication contexts including the self concept, interpersonal, interviewing skills, small group dynamics, and public speaking. Emphasis is placed on analytical and organizational skills, listening, nonverbal and verbal communication, and public speaking communication methodology. ADVISORY: English 250 and English 260.

10579	Lec	PB1	Waddell E	3.2	3.0	MW	0945-1105
10575	Lec	PB1	Waddell E	3.2	3.0	MW	1120-1240

CMUN 6 Introduction to Conflict Resolution

Transferable: CSU; CSU-GE:D7; GAV-GE:D2

Introduction to Conflict Resolution introduces students to conflict resolution and mediation. Integrating theory and practice, students will assess core concepts about the causes and resolution of conflict, and will practice communication skills for conflict resolution. Students will examine how ethnicity, gender, and class affect power in conflict situations. They will be able to formulate appropriate conflict resolution strategies, and will develop and practice various basic co-mediation skills. This course has the option of a letter grade or pass/no pass. This course is also listed as POLS 6, AJ 6 and PSYC 6. ADVISORY: English 250 and English 260.

10028	Lec	SS205	Halper L	3.2	3.0	TR	1250-0210
-------	-----	-------	----------	-----	-----	----	-----------

This service learning section involves community work. See page 64 for details.

CMUN 8 Interpersonal Communication

Transferable: CSU, UC; CSU-GE:A1, IGETC:1C; GAV-GE:A1

This course studies the communication process in an interpersonal (dyadic) setting. This class will explore the ways in which we can improve our communication with others. Verbal and nonverbal messages, self-concept, cultural differences, gender differences, perception, listening and conflict management will be explored.

10583	Lec	PB1	Besson D	3.2	3.0	TR	0945-1105
10581	Lec	PB1	Besson D	3.2	3.0	TR	1120-1240
10582	Lec	PB1	Besson D	3.2	3.0	TR	1250-0210

REGISTER ONLINE ...

Go to www.gavilan.edu and click on the Self-Service Banner icon.

CMUN 8

INTERPERSONAL COMMUNICATION

Fulfills CSU and UC Oral Communication transfer requirements

Study the ways in which we can improve our communication with others. Verbal and nonverbal messages, self-concept, cultural differences, gender differences, perception, listening and conflict management are explored.

Expand your horizons!



Take ... **CMUN 5**

Fundamentals of Communication Studies

Learn about various topics in the communication studies field:

- ▶ The self concept
- ▶ Interpersonal communication
- ▶ Interviewing skills
- ▶ Small group dynamics
- ▶ Public speaking

Satisfies the Social Science requirement for the AA/AS Degree and for transfer to CSU. Also satisfies the Oral Communications requirement for the AA/AS Degree and CSU.

Classroom Locations: Refer to "How to Use This Schedule" on page 5.

CRN Type Room Instructor Hrs. Units Days Begin-End

CMUN 10 Small Group Communication

Transferable: CSU, UC; CSU-GE:A1, IGETC:1C; GAV-GE:A1; CAN:SPCH10

An introductory course that develops basic individual reasoning skills, insights and experiences in information-sharing, interacting, decision-making, problem-solving, resolution of disputes and other issues central to group processes. ADVISORY: Eligible for English 250 and English 260.

10574	Lec	PB1	Cnudde R	3.2	3.0	TR	0810-0930
10566	Lec	PB1	Waddell E	3.2	3.0	MW	0810-0930
10573	Lec	PB1	Avila-Nores C	3.3	3.0	F	0900-1205
10569	Lec	HOL2	Andrade A	3.2	3.0	MW	0945-1105
Above class meets at the Hollister Briggs site.							
10559	Lec	MHG3	Cowan D	3.2	3.0	TR	1120-1240
Above class meets at Morgan Hill Community site.							
10587	Lec	PB1	Morella D	3.2	3.0	MW	0230-0350
10570	Lec	MHG13	Cowan D	3.3	3.0	W	0600-0905
Above class meets at Morgan Hill Community site.							
10572	Lec	HOL2	Andrade A	3.3	3.0	R	0600-0905
Above class meets at the Hollister Briggs site.							

CMUN 129 Presentation Graphics - MS Powerpoint

Transferable: CSU

This introductory course in presentation graphics will use Microsoft Office's "PowerPoint" software to create a computerized presentation with text and objects. This course has the option of a letter grade or pass/no pass. May be repeated three times for credit. This course is also listed as CSIS 129. ADVISORY: CSIS 126 or word processing skills in the Windows environment.

10931	Lec	PB3	Venable E		1.0		
Orientation required. Schedule available in PB 3 (Business Skills Lab) Open-Entry/Open-Exit Class							
10940	Lec	HOL3	Bryson M	4.6	1.0	MW	1120-0125
11/09/09 - 12/09/09 Above class meets at the Hollister Briggs site.							

Computer Art: see ART 48A/B, CSIS or Digital Media

COMPUTER GRAPHICS AND DESIGN

CGD 2 2D/3D Technical Computer Graphics I

Transferable: CSU

Introduction to graphic and design competencies architects, engineers, game/simulation developers, industrial designers and other careers use when producing and marketing real and/or virtual products. Prepares students to create consumer products, buildings and other designed objects by developing freehand sketches, creating SolidWorks models and/or other graphics while applying theory and knowledge of elements and principles of visual design, creative problem solving, typography, professional ethics and research skills. May be repeated once for credit. This course has the option of a letter grade or pass/no pass. ADVISORY: LIB 3 and MATH 404G.

10797	L/L	LI126	McLaughlin C	3.2	3.0	TR	1250-0210
-------	-----	-------	--------------	-----	-----	----	-----------

CGD 4 2D/3D Technical Computer Graphics II

Transferable: CSU

Intermediate computer graphics design course expands skills and concepts introduced in CGD 2. Develops design and graphic skills required to create, explain, model, render, and animate products using a problem solving process and knowledge of ergonomics, materials, design principles and color theories. Projects assigned integrate technology with design and focus upon creating, developing and marketing useful products by developing and visually communicating ideas that are necessary for succeeding in desired design career(s). May be repeated once for credit. ADVISORY: Completion of CGD 2 with a grade of C or better.

10798	L/L	LI126	McLaughlin C	2.8	3.0	TR	0220-0330
-------	-----	-------	--------------	-----	-----	----	-----------

Check out *Classes offered at the satellite sites...*

Hollister classes - page 60

Morgan Hill classes - page 62



Come on a voyage of self-discovery and become more culturally fluent.

Take...

CMUN 4

Intercultural Communication

- ☞ Learn about people from different cultures.
- ☞ Increase your awareness and understanding of diversity.
- ☞ Study verbal and nonverbal communication.
- ☞ Become a competent communicator in an intercultural society.

CMUN 4 satisfies the Social Science requirement for the Gavilan AA/AS Degree and for transfer to UC and CSU.

Now Offering!

- Associate of Arts Degree in Communication Studies
- Certificate of Achievement in Interpersonal Communication
- Certificate of Achievement in Communication Studies

Note: These two Certificates of Achievement are currently listed as Certificates of Proficiency. The title change will allow the certificates to appear on students' transcripts. The change is pending Chancellor's Office approval.

Get started today. Call Denise Besson Silvia at 408-848-4831 or visit www.gavilan.edu/comm.

Gain SolidWorks Technical Skills for Rewarding Careers

Computer Graphics and Design (CGD)

Prepare for employment in:

- Engineering
- Architecture
- Product Design
- Fashion Industry
- Interior Design
- Video Games/Simulation



Career Info:
www.gavilan.edu/CGD

CRN Type Room Instructor Hrs. Units Days Begin-End

CGD 8 Advanced Computer Graphics for Design Application I

Transferable: CSU

Advanced course in applied computer graphics and associated interdisciplinary design proficiencies required by careers that design, engineer, manufacture and/or market products. Applies theories, principles and skills covered in CGD 4 and integrates business, sustainable design, and hybrid products. Design solutions reflect technical understanding, aesthetic principles and addresses societal needs in a cost effective manner. Presentations include animating and rendering models of real and/or virtual products that address human factors/ergonomics, usability, life cycle analysis and sustainability. Portfolios support advancement in student-selected career pathways by communicating competence in computer graphics and design. May be repeated once for credit. ADVISORY: Eligible for English 250, 260 and Mathematics 233.

10799 L/L LI128 McLaughlin C 2.8 3.0 TR 0220-0330

CGD 110 Computer Graphics Lab

Transferable: CSU

Structured for students concurrently enrolled in computer graphics and art classes. Provides supervised practice and individualized computer assisted learning on software applications and techniques commonly found in the computer graphic design field. This is an open entry/exit class and may be repeated three times. This course has the option of a letter grade or pass/no pass. ADVISORY: Concurrent enrollment in corresponding computer graphic and design classes. Computer lab work can be done both in lab and off-site.

10791 Lab LI126 McLaughlin C 1.0
 10793 Lab LI126 McLaughlin C 2.0
 10795 Lab LI126 McLaughlin C 3.0
 10796 Lab LI126 McLaughlin C 4.0

CGD 190 Occupational Work Experience/Computer Graphics & Design

Transferable: CSU

College credit for learning experience obtained on the job in accordance with a training plan developed cooperatively between the employer, college and student. 75 hours per semester per unit or 60 hours per semester for unpaid experience. This is a pass/no pass course. May be taken for a maximum of 16 work experience units. REQUIRED: Declared vocational major. Concurrent enrollment in seven or more units (including CWE units, except for summer school. For summer school enrollment in one other class is required). Minimum 2.0 G.P.A. Computer lab work can be done both in lab and off-site.

Mandatory course orientation for the following classed will be conducted Tuesday October 6, 2009 from 530 pm-630 pm in the North/South Lounge, Wednesday, October 7, 2009 from 430 pm -530 pm in the North/South Lounge and Thursday October 8, 2009 from 8 am to 9 am in the North/South Lounge. Students need to attend one of the three meetings. Please contact Susan Sweeney, CWE Coordinator at (408) 848-4813 for more information.

10846 Wrk Ex LI101A Sweeney S 1.0
 10847 Wrk Ex LI101A Sweeney S 2.0
 10848 Wrk Ex LI101A Sweeney S 3.0
 10849 Wrk Ex LI101A Sweeney S 4.0

COMPUTER SCIENCE & INFORMATION SYSTEMS

CSIS 1 Computer Literacy - MS Office

Transferable: CSU, UC; GAV-GE:E2; CAN:CSCI2

An introduction to terminology, design, operation for the novice user. Student will gain experience using the Internet for searches and email. They will complete projects using various software including word processing, spreadsheets, database, presentation graphics, and integration. This course has the option of a letter grade or pass/no pass. ADVISORY: Eligible for English 250 and English 260; completion of CSIS 122.

10224 Lec PB4 Gaffney S 4.6 2.0 MW 0900-1105
 09/02/09 - 10/21/09
 10227 Lec PB4 Gaffney S 4.6 2.0 MW 0900-1105
 10/26/09 - 12/09/09
 10241 Lec HOL3 Bryson M 4.6 2.0 MW 1120-0125
 09/14/09 - 11/04/09 Above class meets at the Hollister Briggs site.
 10243 Lec HOL3 Thompson F 3.3 2.0 R 0600-0905
 09/24/09 - 12/10/09 Above class meets at the Hollister Briggs site.
 10883 Lec PB3 Gaffney S 3.3 2.0 T 0600-0905
 09/29/09 - 12/08/09

CRN Type Room Instructor Hrs. Units Days Begin-End

CSIS 2 Computers in Business - MS Office

Transferable: CSU; GAV-GE:E2; CAN:BUS6

Introduction to computerized business data processing, information management systems, computer hardware, office automation, telecommunications, computer languages, systems analysis and design; hands on experience with common business software packages including word processing, spreadsheets, data base management, presentation graphics as well as systems software and Internet applications. This course has the option of a letter grade or pass/no pass. ADVISORY: Eligible for Mathematics 233, English 260 and English 250, and CSIS 122

This following two Hybrid classes will be delivered partially online and also meet face to face at select locations. You must have an email account to take a distance ed course. Unless you have made prior arrangements with the instructor, come to class in person on the first day of the semester or the first day of class for short-term courses. If you do not show up on the first day you may be dropped. For help, contact your instructor or email disted@gavilan.edu.

10289 ONLINE Venable E 4.0
 Lab PB3 Bryson M 1.6 T 0945-1105
 This Hybrid class will be delivered partially online and also meet face to face at select locations. See statement above.

10292 ONLINE Venable E 4.0
 Lab PB3 Bryson M 1.6 F 0945-1105
 This Hybrid class will be delivered partially online and also meet face to face at select locations. See statement above.

CSIS 2L Computers in Business Lab - MS Office

Transferable: CSU

Computer Lab emphasizing business application in Microsoft Word, Excel, Access, Power Point and Integration. Internet searches are included. This course has the option of a letter grade or pass/no pass. Since supervised repetition and practice enhance skills/proficiencies. This course may be repeated once for credit.

10293 Lab PB3 Bryson M 1.6 1.0 T 0945-1105
 10295 Lab PB3 Bryson M 1.6 1.0 F 0945-1105
 10933 Lab PB4 Thompson F 3.3 1.0 M 0600-0905

CSIS 3 Research Skills

Transferable: CSU

Research and evaluation skills using the Internet and other electronic resources, as well as traditional printed materials. Also listed as LIB 3. This course has the option of a letter grade or pass/no pass. May be repeated once for credit. ADVISORY: Eligible for English 250 and 260.

10807 ONLINE Meader S 2.0
 10/14/09 - 12/08/09 You must have an email account to take this course. Start your course by going to www.gavilan.edu/disted. Unless you have made prior arrangements with the instructor, you MUST log on by 11:59 pm on the first day of class. Late adds must login within 24 hours of adding this course. If you miss the deadline you may be dropped. For help, contact your instructor or email disted@gavilan.edu.

CSIS 5 C++ Scientific Programming

Transferable: CSU, UC; CAN:CSCI4

An introduction to computer problem solving and programming using the C++ language for science and engineering majors. Students will write programs for a variety of scientific and mathematical applications. This course has the option of a letter grade or pass/no pass. PREREQUISITE: Mathematics 1A ADVISORY: Completion of CSIS 10.

10305 ONLINE Van Tassel D 3.0
 L/L MHG8 Van Tassel D 3.3 M 0600-0905

This Hybrid class will be delivered partially online and also meet face to face at select locations. You must have an email account to take a distance ed course. Unless you have made prior arrangements with the instructor, come to class in person on the first day of the semester or the first day of class for short-term courses. If you do not show up on the first day you may be dropped. For help, contact your instructor or email disted@gavilan.edu.

10306 ONLINE Van Tassel D 3.0
 You must have an email account to take this course. Start your course by going to www.gavilan.edu/disted. Unless you have made prior arrangements with the instructor, you MUST log on by 11:59 pm on the first day of the semester. Late adds must login within 24 hours of adding this course. If you miss the deadline you may be dropped. For help, contact your instructor or email disted@gavilan.edu.

Less Grade Stress!! Many CSIS and BUS classes may be taken for either a letter grade or on a pass/no pass basis. Make your choice when registering or until the NRS deadline (Oct. 1). But remember that you cannot change your mind once you're decided. See Pass/No Pass Grading Option on page 26 for more details.

CRN Type Room Instructor Hrs. Units Days Begin-End

CSIS 6 Web Page Authoring I

Transferable: CSU; GAV-GE:E2

An introduction to using Hypertext Mark-Up Language (HTML) and Extensible HTML (XHTML) to create web pages which can be uploaded and displayed on the World Wide Web. Students will use HTML/XHTML to create web pages with text in various sizes and colors, links to other sites, background color or patterns, graphics, tables and mailto links. Principles of design and color as they apply to screen presentations will be included. This course has the option of a letter grade or pass/no pass. May be repeated three times for credit. Also listed as LIB 6 and DM 6. ADVISORY: CSIS 1 or CSIS 2 or CSIS 3/LIB 3 advised.

10312 ONLINE Howell J 2.0
09/03/09 - 10/26/09 You must have an email account to take this course. Start your course by going to www.gavilan.edu/disted. Unless you have made prior arrangements with the instructor, you MUST log on by 11:59 pm on the first day of class. Late adds must login within 24 hours of adding this course. If you miss the deadline you may be dropped. For help, contact your instructor or email disted@gavilan.edu.

10316 ONLINE Howell J 2.0
10/19/09 - 12/12/09 You must have an email account to take this course. Start your course by going to www.gavilan.edu/disted. Unless you have made prior arrangements with the instructor, you MUST log on by 11:59 pm on the first day of class. Late adds must login within 24 hours of adding this course. If you miss the deadline you may be dropped. For help, contact your instructor or email disted@gavilan.edu.

CSIS 8 Introduction to the Internet

Transferable: CSU; GAV-GE:E2

This course will provide students the opportunity to learn to use the Internet and the World Wide Web. Topics to be covered include history of the Internet and development of the WWW, web browsers, search engines, tools to develop web pages, how to get connected and local Internet providers. This is a pass/no pass course. May be repeated three times for credit. ADVISORY: CSIS 124

10322 ONLINE Venable E 1.0
09/08/09 - 10/30/09 You must have an email account to take this course. Start your course by going to www.gavilan.edu/disted. Unless you have made prior arrangements with the instructor, you MUST log on by 11:59 pm on the first day of class. Late adds must login within 24 hours of adding this course. If you miss the deadline you may be dropped. For help, contact your instructor or email disted@gavilan.edu.

10330 ONLINE Venable E 1.0
10/26/09 - 12/18/09 You must have an email account to take this course. Start your course by going to www.gavilan.edu/disted. Unless you have made prior arrangements with the instructor, you MUST log on by 11:59 pm on the first day of class. Late adds must login within 24 hours of adding this course. If you miss the deadline you may be dropped. For help, contact your instructor or email disted@gavilan.edu.

CSIS 10 BASIC Programming

Transferable: CSU, UC

This course is an introduction to programming using BASIC. No previous programming background is assumed. This is a good class for those new to programming and recommended for non-programmers that want to take other programming classes. This course has the option of a letter grade or pass/no pass. ADVISORY: CSIS 1 or CSIS 2 or equivalent experience.

10884 Lec HOL3 Thompson F 3.3 2.0 F 0900-1205
09/18/09 - 12/11/09 Above class meets at the Hollister Briggs site.

10244 Lec LI126 Littig A 4.6 2.0 TR 0900-1105
10/15/09 - 12/10/09

CSIS 18 UNIX/C++ Programming

Transferable: CSU, UC

An introduction to the C++ programming language and the UNIX operating system. Topics include programming on a UNIX system, including C/C++ language, shell programming, and the interface between C++ and UNIX. This course has the option of a letter grade or pass/no pass. Concurrent enrollment in CSIS 18L is required. COREQUISITE: CSIS 18L UNIX/C++ Programming Lab ADVISORY: CSIS 48 UNIX Operating System, CSIS 10 BASIC Programming or other programming experience.

10301 Lec MHG8 Van Tassel D 3.3 3.0 M 0600-0905
Above class meets at Morgan Hill Community site.

10303 ONLINE Van Tassel D 3.0
You must have an email account to take this course. Start your course by going to www.gavilan.edu/disted. Unless you have made prior arrangements with the instructor, you MUST log on by 11:59 pm on the first day of the semester. Late adds must login within 24 hours of adding this course. If you miss the deadline you may be dropped. For help, contact your instructor or email disted@gavilan.edu.

GoPrint You can now use the GoPrint system to print documents at all of Gavilan College's computer labs. No need to fumble around with coins! With your GoPrint or ASB card, you're good to go. See ad on page 8.



CSIS 10 BASIC Programming

An introductory course for those students exploring a computer programming career.

Transfers to both UC and CSU.



Brush Up your Software Skills

Most Computer Applications classes are repeatable.

CRN Type Room Instructor Hrs. Units Days Begin-End

CSIS 18L UNIX/C++ Programming Lab

Transferable: CSU, UC

Supplemental practice in coursework associated with this course is provided. Concurrent enrollment in CSIS 18 is required. This course has the option of a letter grade or pass/no pass. COREQUISITE: CSIS 18 UNIX/C++ Programming

10304 ONLINE Van Tassel D 1.0
You must have an email account to take this course. Start your course by going to www.gavilan.edu/disted. Unless you have made prior arrangements with the instructor, you MUST log on by 11:59 pm on the first day of the semester. Late adds must login within 24 hours of adding this course. If you miss the deadline you may be dropped. For help, contact your instructor or email disted@gavilan.edu.

CSIS 24 Java Programming I

Transferable: CSU, UC

Introduction to Java programming. Includes learning the Java environment, using and creating Java applets, and writing stand-alone applications. Covers the Java environment, object-oriented programming, language basics, classes, interfaces, packages, threads, and exceptions. This course has the option of a letter grade or pass/no pass. ADVISORY: CSIS 45 C++ Programming or equivalent programming experience.

10297 ONLINE Van Tassel D 4.0
You must have an email account to take this course. Start your course by going to www.gavilan.edu/disted. Unless you have made prior arrangements with the instructor, you MUST log on by 11:59 pm on the first day of the semester. Late adds must login within 24 hours of adding this course. If you miss the deadline you may be dropped. For help, contact your instructor or email disted@gavilan.edu.

10298 ONLINE Van Tassel D 4.0
L/L LI126 Van Tassel D 3.2 MW 0945-1105
This Hybrid class will be delivered partially online and also meet face to face at select locations. You must have an email account to take a distance ed course. Unless you have made prior arrangements with the instructor, come to class in person on the first day of the semester or the first day of class for short-term courses. If you do not show up on the first day you may be dropped. For help, contact your instructor or email disted@gavilan.edu.

CRN Type Room Instructor Hrs. Units Days Begin-End

NEW CSIS 42 Python Programming

Transferable: CSU, UC

Introduction to the interpreted language called Python. Study and create programs that perform various tasks, including text and file manipulation, internet scripting, data structures, testing, and practical problem solving with examples. Covers object oriented programming and the Python Standard Library. ADVISORY: CSIS 10 or programming experience.

10886 ONLINE Howell P 4.0

You must have an email account to take this course. Start your course by going to www.gavilan.edu/disted. Unless you have made prior arrangements with the instructor, you MUST log on by 11:59 pm on the first day of the semester. Late adds must login within 24 hours of adding this course. If you miss the deadline you may be dropped. For help, contact your instructor or email disted@gavilan.edu.

CSIS 45 C++ Programming I

Transferable: CSU, UC; GAV-GE:E2; CAN:CSCI18

An introduction to the concepts and methods of computer programming using C++. Students will be introduced to procedural and object-oriented programming design methodology. Topics covered include variable and constant declarations, selection statements, repetition, functions and recursion, arrays, strings, pointers, and an introduction to classes and objects. This course will prepare students for the Programming II class. This course has the option of a letter grade or pass/no pass. ADVISORY: CSIS 10 or equivalent. Math 205 (Elementary Algebra)

10299 ONLINE Van Tassel D 4.0

You must have an email account to take this course. Start your course by going to www.gavilan.edu/disted. Unless you have made prior arrangements with the instructor, you MUST log on by 11:59 pm on the first day of the semester. Late adds must login within 24 hours of adding this course. If you miss the deadline you may be dropped. For help, contact your instructor or email disted@gavilan.edu.

10300 ONLINE Van Tassel D 4.0
L/L MHG8 Van Tassel D 3.3 M 0600-0905

This Hybrid class will be delivered partially online and also meet face to face at select locations. You must have an email account to take a distance ed course. Unless you have made prior arrangements with the instructor, come to class in person on the first day of the semester or the first day of class for short-term courses. If you do not show up on the first day you may be dropped. For help, contact your instructor or email disted@gavilan.edu.

CSIS 48 UNIX/Linux Operating System

Transferable: CSU, UC

This course will provide the basics of the UNIX/Linux operating system, including the history and the use of UNIX/Linux with hands-on experience using commands and files. Topics to be covered include basic UNIX/Linux commands, text editing, files and directories, electronic mail, pipes and filters, and shell programming. This course has the option of a letter grade or pass/no pass. ADVISORY: CSIS 1 or CSIS 2 or equivalent computer experience.

10766 ONLINE Van Tassel D 4.0
L/L MHG8 Van Tassel D 3.3 T 0600-0905

This Hybrid class will be delivered partially online and also meet face to face at select locations. You must have an email account to take a distance ed course. Unless you have made prior arrangements with the instructor, come to class in person on the first day of the semester or the first day of class for short-term courses. If you do not show up on the first day you may be dropped. For help, contact your instructor or email disted@gavilan.edu.

10767 ONLINE Van Tassel D 4.0

You must have an email account to take this course. Start your course by going to www.gavilan.edu/disted. Unless you have made prior arrangements with the instructor, you MUST log on by 11:59 pm on the first day of the semester. Late adds must login within 24 hours of adding this course. If you miss the deadline you may be dropped. For help, contact your instructor or email disted@gavilan.edu.

CSIS 54 Perl Programming

Transferable: CSU, UC

Introduction to the interpreted language called PERL, the Practical Extraction and Report Language. Writing of programs that perform various tasks, including text, file and process manipulation. Semantics and syntax of the Perl language, including discussion of the practical kinds of problems that Perl can solve and provides examples. This course has the option of a letter grade or pass/no pass. Concurrent enrollment in CSIS 54L is required. COREQUISITE: CSIS 54L Perl Programming Lab ADVISORY: CSIS 45 C++ Programming or equivalent programming experience.

10309 Lec MHG8 Tarvin J 3.3 3.0 R 0600-0905
Above class meets at Morgan Hill Community site.

CRN Type Room Instructor Hrs. Units Days Begin-End

CSIS 54L Perl Programming Lab

Transferable: CSU, UC

Supplemental practice in coursework associated with this course is provided. Concurrent enrollment in CSIS 54 is required. COREQUISITE: CSIS 54 Perl Programming

10308 ONLINE Tarvin J 1.0

You must have an email account to take this course. Start your course by going to www.gavilan.edu/disted. Unless you have made prior arrangements with the instructor, you MUST log on by 11:59 pm on the first day of the semester. Late adds must login within 24 hours of adding this course. If you miss the deadline you may be dropped. For help, contact your instructor or email disted@gavilan.edu.

CSIS 74 Advanced Photoshop

Transferable: CSU; GAV-GE:C1

This course is for the PhotoShop-experienced student and explores PhotoShop's advanced features in depth. Students work on projects, which challenge their creativity and technical ability, and will be encouraged to develop complex projects for the web and for the printed page. May be repeated three times for credit. This course has the option of a letter grade or pass/no pass. This course is also listed as ART 74 and DM 74. ADVISORY: CSIS 75 PhotoShop I

10319 Lec MHG5 Grzan R 3.3 3.0 R 0630-0935
Above class meets at Morgan Hill Community site.

CSIS 75 PhotoShop I - Adobe PhotoShop

Transferable: CSU; GAV-GE:C1

This course is based on the software application Adobe PhotoShop. Students learn to scan photographs and manipulate them using Photoshop tool box and special effects filters. They will learn to correct photos; mask image using channels; create duotone, tritone, and quadtone images; prepare photos for use in printing and on the web. This course has the option of a letter grade or pass/no pass. May be repeated three times for credit. Students who repeat this course will learn new and advanced features. This course is also listed as DM 75. ADVISORY: CSIS 124 (Windows Fundamentals), CSIS 2L

10903 L/L LI128 Powers K 3.3 3.0 M 0330-0635

10327 L/L MHG5 Grzan R 3.3 3.0 T 0630-0935
Above class meets at Morgan Hill Community site.

CSIS 77 Introduction to Digital Media and its Tools

Transferable: CSU, UC; GAV-GE:C1

An introduction to the field of digital media, including history, social impact, concepts, career options and industry trends. Applying learned visual and aural design principles, students will explore the use of computer-based tools in the design and production of digital media by creating and editing digital images, sounds, video, animation, and text. A comprehensive term project for publication on the web or CD ROM will be required. This course is also listed as ART 77 and DM 77. This course has the option of a letter grade or pass/no pass. May be repeated twice for credit. ADVISORY: CSIS 124, CSIS 1, CSIS 2/2L, CSIS 3, or familiarity using the Macintosh or Windows operating system.

10934 L/L LI128 Beede R 3.2 3.0 TR 0945-1105

10889 L/L MHG5 Mullins A 3.3 3.0 W 0600-0905
Above class meets at Morgan Hill Community site.

CSIS 80 Digital Photography

Transferable: CSU, UC; GAV-GE:C1

The study of digital photography from digital camera to the computer-based printer or digital media. Artistic, theoretical, and technical aspects will be considered. Topics include information about types and purchasing of digital cameras; theory, mechanics, and art of digital imagery; digital darkroom; eccentricities of digital photo taking; stitching photos for virtual reality; and preparing digital images for print, World Wide Web and other digital media. This course has the option of a letter grade or pass/no pass. This course is also listed as ART 80 and DM 80. ADVISORY: CSIS 1 or CSIS 2/2L or ART 8A or equivalent computer experience.

10927 L/L LI128 Edberg J 5.4 3.0 MW 1250-0315

A counselor's signature is required

if you take over 17.99 units (spring/fall) or over 5.99 units (summer). You do not need a counselor's signature to register for a class with a prerequisite that was successfully completed at Gavilan.

Classroom Locations: Refer to "How to Use This Schedule" on page 5.

CRN Type Room Instructor Hrs. Units Days Begin-End

CSIS 85 Web Design I: Dreamweaver

Transferable: CSU; GAV-GE:C1

Basic and intermediate principles of designing Web pages/sites using the Dreamweaver web design software and HTML. Emphasis will be on good design and the use of tables, frames, forms, rollovers, DHTML, XHTML, behaviors, and CSS. Also includes site maintenance and the integration of multimedia components such as graphics, sound, animation, and video. This course is for the content person to design, develop, and maintain effective Web sites. This course is also listed as ART 85 and DM 85. This course has the option of a grade or pass/no pass. May be repeated twice for credit. ADVISORY: CSIS 6 or basic knowledge of HTML.

10909 Lec HOL3 Lee K 3.3 2.0 M 0230-0535
Above class meets at the Hollister Briggs site.

10334 ONLINE Lawrence S 2.0
10/14/09-12/18/09 You must have an email account to take this course. Start your course by going to www.gavilan.edu/disted. Unless you have made prior arrangements with the instructor, you MUST log on by 11:59 pm on the first day of the semester. Late adds must login within 24 hours of adding this course. If you miss the deadline you may be dropped. For help, contact your instructor or email disted@gavilan.edu.

CSIS 107 Digital Media Design

Transferable: CSU

Fundamentals of design for visual, time-based, interactive, and sound arts as applied to digital media. Includes basic storytelling, graphic design, information architecture, and human factors. Page layout, scriptwriting, storyboards, and flow charts will be used as tools applicable to the design and development of business presentations, interactive media, educational multimedia, animation, web sites, video games, and film/video. This course has the option of a letter grade or pass/no pass. Also listed as ART 107 and DM 107. ADVISORY: CSIS 1 or CSIS 2/2L or equivalent computer experience

10941 L/L LI128 Fainshtein V 3.3 2.0 R 0330-0635

CSIS 108 Digital Media Lab

Transferable: CSU; GAV-GE:C1

Supervised practice and individualized computer assisted learning of software applications and techniques commonly found in the design and production of digital media (e.g., digital art and imaging, digital photography, digital print, digital audio/video, web design/authoring, DVD/CD ROMs, animation). Supplements lecture courses. Open entry/exit, so may be added at anytime during the semester. This is a pass/no pass course. May be repeated three times for credit. Also listed as ART 108 and DM 108. ADVISORY: CSIS 1 or CSIS 2/2L or equivalent computer experience.

10727 Lab LI128 Beede R .5

10756 Lab LI128 Beede R 1.0

CSIS 110 Interactive Animation: Flash

Transferable: CSU; GAV-GE:C1

The production of vector graphics, animation, and interactive multimedia in Shockwave-Flash format for web pages and other digital media. Design of highly interactive web site interfaces and animated games using Flash actions (scripting). Useful for web designers/developers, animators, and multimedia authors. This course has the option of a letter grade or pass/no pass. Also listed as ART 110 and DM 110. May be repeated three times for credit. ADVISORY: CSIS 1, CSIS 2/2L, CSIS 124 or basic computer knowledge.

10894 L/L LI128 Beede R 3.2 3.0 MW 1120-1240

CSIS 112 Keyboard Speed Building

Transferable: CSU

This self-paced course is designed for students who know the alphabetic keyboard by touch and who want to develop their keyboarding speed. Students will use a microcomputer to keyboard a series of straight-copy timings, which will enable them to achieve a high level of skill. This is a pass/no pass course. May be repeated once for a total of 1 unit. ADVISORY: CSIS 122 or knowledge of keyboard with keyboarding speed of at least 25 wpm.

10248 Lab PB3 Gaffney S .5
Orientation required. Schedule available in PB 3 (Business Skills Lab) Open-Entry/Open-Exit Class



CSIS 42 PYTHON Programming



An object-oriented scripting language



CSIS 48 UNIX/Linux Operating System

Offered online and as a hybrid lec/online class!

4 units

Basic UNIX/Linux commands, test editing, files and directories, electronic pipes and filters.

Instructor: Dennie Van Tassel Transferable: UC and CSU

DESIGN YOUR OWN WEB SITE!

CSIS 85 Web Design I: Dreamweaver

Now using Dreamweaver CS3

Learn to design, develop and maintain effective Web sites.

Also listed as ART 85 & DM 85.

CSIS 74 Advanced Photoshop

Now offered in Morgan Hill!

Learn the advanced features of Photoshop CS4 and create professional artwork.



Also listed as ART 74 and DM 74.

New! Liberal Arts Associate's Degree Areas of Emphasis

Check out the updated Catalog online - www.gavilan.edu/catalog - click on Liberal Arts.

CRN Type Room Instructor Hrs. Units Days Begin-End

CSIS 113 Introduction to Digital Video

Transferable: CSU; GAV-GE:C1

Introduction to the aesthetic and technical aspects of digital video recording, non-linear editing, special effect generation, and production of video (and associated audio) using the personal computer equipped with specialized software such as iMovie, Final Cut Pro, and After Effects. Also considered will be the preparation of digital video for use in interactive media such as CD, DVD, and the World Wide Web. Students will produce a final digital video project on DVD. This course has the option of a letter grade or pass/no pass. May be repeated 2 times for credit. Also listed as ART 113 and DM 113. ADVISORY: CSIS 1 or CSIS 2/2L or equivalent computer experience

10897 L/L LI128 Beede R 3.2 3.0 MW 0945-1105

CSIS 114 Digital Media Production

Transferable: CSU

A team oriented practicum that focuses on the application of learned skills to the production of digital media and digital print projects, such as web sites, CD ROM, and DVDs. Project development will be accomplished according to team derived master schedules. Lectures will be on project management, work coordination and production techniques, client-team interface, asset management and integration, budget estimates, testing, and copyright infringement. Please note that this is very much a team oriented class. This course has the option of a letter grade or pass/no pass. This course is also listed as ART 114 and DM 114. ADVISORY: At least one of the following: ART 75, CGE 2, JOUR 18A, MUS 21, CSIS 7, CSIS 71, OR CSIS 77. or possess equivalent skills from any one of the following areas: digital media, computer graphics, digital print, film, TV/video, journalism (publishing), drawing or illustration, web design/development, business/marketing, or programming.

10944 Lec LI128 Beede R 3.2 2.0 TR 1120-1240

CSIS 120 Computerized Accounting - QuickBooks

Transferable: CSU

An introduction to computer assisted accounting. Hands-on use of a microcomputer menu-driven accounting package to do general ledger, sales journal, cash receipts journal, cash payments journal, purchases journal, payroll, receivables, payables and related financial reports. This course has the option of a letter grade or pass/no pass. Repeatable whenever a new software package is adopted. This course is also listed as ACCT 120. ADVISORY: CSIS 1 or CSIS 2 or the equivalent computer experience. ACCT 20 or ACCT 101 or ACCT 103 or ACCT 105 or the equivalent accounting experience.

10765 L/L MHG5 Brown R 3.0 2.0 R 0300-0555
Above class meets at Morgan Hill Community site.

10176 L/L HOL3 College A 1.3 2.0 F 0530-0835
Above class meets at the Hollister Briggs site.

CSIS 121 Spreadsheet - MS Excel

Transferable: CSU

Introduction to the computer spreadsheet software. A hands-on approach to learning terms, commands, and applications of a spreadsheet program. This course will help prepare students for taking the Excel MOUS (Microsoft Office User Specialist) exams. This course has the option of a letter grade or pass/no pass. May be repeated once for credit when the software changes. Also listed as ACCT 121. ADVISORY: CSIS 1 or CSIS 2 or equivalent computer experience.

10880 Lec MHG8 Mendez F 3.3 2.0 F 0900-1205
09/25/09 - 12/11/09 Above class meets at Morgan Hill Community site.

10882 Lec HOL3 Mendez F 3.3 2.0 W 0600-0905
09/30/09 - 12/09/09 Above class meets at the Hollister Briggs site. ROP course.

10930 Lec PB4 Thompson F 3.3 2.0 W 0600-0905
09/30/09 - 12/09/09

CRN Type Room Instructor Hrs. Units Days Begin-End

CSIS 122 Computer Keyboarding

Transferable: CSU

A self-paced course for students who wish to master the alphabetic and numeric keyboard on the computer. This course is designed for students who do not know the alphabetic keyboard by "touch" and for those who want to improve their ability to type straight copy with increased speed and accuracy. The course provides "hands-on" instruction to help students reach optimum computer keyboarding skills within a limited time. This is a pass/no pass course. Course may be repeated until 3 units are accrued.

10734 Lab PB3 Venable E .5 day/time - see instructor
Orientation required. Schedule available in PB 3 (Business Skills Lab) Open-Entry/Open-Exit Class

10731 Lab PB3 Venable E 1.0 day/time - see instructor
Orientation required. Schedule available in PB 3 (Business Skills Lab) Open-Entry/Open-Exit Class

10742 Lab MHG8 Hampton D 2.0 .5 S 0830-1020
Above class meets at Morgan Hill Community site.

10744 Lab MHG8 Hampton D 4.0 1.0 S 0830-1220
Above class meets at Morgan Hill Community site.

10736 Lab HOL3 Bryson M 3.2 .5 MW 0945-1105
Above class meets at the Hollister Briggs site.

10737 Lab HOL3 Bryson M 6.0 1.0 MW 0945-1240
Above class meets at the Hollister Briggs site.

10739 Lab HOL3 Bryson M 3.2 .5 MW 1120-1240
Above class meets at the Hollister Briggs site.

10741 Lab HOL3 Bryson M 4.6 1.0 MW 1120-0125
Above class meets at the Hollister Briggs site.

10745 Lab PB3 Gaffney S 1.3 .5 T 0600-0735

10746 Lab PB3 Gaffney S 3.3 1.0 T 0600-0905

10751 Lab HOL3 Hampton D 2.0 .5 T 0600-0720
Above class meets at the Hollister Briggs site.

10752 Lab HOL3 Hampton D 3.3 1.0 T 0600-0905
Above class meets at the Hollister Briggs site.

CSIS 124 Windows Fundamentals

Transferable: CSU

This course provides fundamental information on the Windows environment for the computer. Introductory Windows operations and file management are covered. This is a pass/no pass course. This course may be repeated three times for credit. ADVISORY: Basic keyboarding skill.

10856 Lec HOL3 Bryson M 4.6 1.0 MW 0900-1105
09/14/09 - 10/14/09 Above class meets at the Hollister Briggs site.

10855 Lec PB4 Milar E 1.6 1.0 T 1250-0210
09/15/09 - 11/24/09

CSIS 126 Word Processing - MS Word

Transferable: CSU

This introductory course for word processing with Windows is designed for business and non-business majors. Students will develop word processing skills to create a document, select and edit text, move and copy text, use the spelling, grammar, and thesaurus features, format text, and create headers and footnotes for a research paper. This course has the option of a letter grade or pass/no pass and may be repeated for credit when the software changes. ADVISORY: Eligible for English 260 and basic keyboarding skills.

10885 Lec MHG8 Hampton D 3.6 2.0 S 0900-1220
10/10/09 - 12/12/09 Above class meets at Morgan Hill Community site.

10938 Lec HOL3 Bryson M 4.6 2.0 MW 0900-1105
10/19/09 - 12/19/09 Above class meets at the Hollister Briggs site.

10254 Lec PB4 Milar E 1.6 2.0 M 1250-0210

10858 Lec HOL3 Mendez F 3.3 2.0 M 0600-0905
09/28/09 - 12/07/09 Above class meets at the Hollister Briggs site. ROP course.

10336 ONLINE Conrey J 2.0

 You must have an email account to take this course. Start your course by going to www.gavilan.edu/disted. Unless you have made prior arrangements with the instructor, you MUST log on by 11:59 pm on the first day of the semester. Late adds must login within 24 hours of adding this course. If you miss the deadline you may be dropped. For help, contact your instructor or email disted@gavilan.edu.

Don't go to the wrong city

MHG = Morgan Hill Community Center site

HOL = Hollister Briggs Building site

CRN Type Room Instructor Hrs. Units Days Begin-End

CSIS 129 Presentation Graphics - MS PowerPoint

Transferable: CSU

This introductory course in presentation graphics will use Microsoft Office's "PowerPoint" software to create a computerized presentation (slide show) with text and objects. This course is also listed as CMUN 129. This course has the option of a letter grade or pass/no pass. May be repeated three times for credit. ADVISORY: CSIS 126 or word processing skills in the Windows environment.

10932	Lec	PB3	Venable E	1.0			
Orientation required. Schedule available in PB 3 (Business Skills Lab) Open-Entry/Open-Exit Class							
10939	Lec	HOL3	Bryson M	4.6	1.0	MW	1120-0125
11/09/09 - 12/09/09 Above class meets at the Hollister Briggs site.							

CSIS 132 Intermediate Word Processing - MS Word

Transferable: CSU

This course covers formatting with macros and styles, mail merge techniques, sorting data in tables, preparing and protecting forms. These techniques will be applied to a variety of different documents: contracts, reports, surveys, manuscripts, and various types of letters. Other topics include working with shared documents in a workgroup, integrating applications and creating hyperlinks for workgroup settings using Microsoft Word. This course has the option of a letter grade or pass/no pass. May be repeated three times for credit. ADVISORY: CSIS 126 Word Processing - MS Word

10337		ONLINE	Conrey J	2.0			
You must have an email account to take this course. Start your course by going to www.gavilan.edu/disted . Unless you have made prior arrangements with the instructor, you MUST log on by 11:59 pm on the first day of the semester. Late adds must login within 24 hours of adding this course. If you miss the deadline you may be dropped. For help, contact your instructor or email disted@gavilan.edu .							

CSIS 140 Basic Digital Film/Video Production

Transferable: CSU, UC; GAV-GE:C1

An on-line self-paced course covering the basics of film/video production and post production (editing) using "easy to use" computer software such as Apple's iMovie. Beneficial for students who are producing a video/film project as a requirement for another college course, extra skills development, or for self interest. Completion of the associated class or personal project in DVD format using either personal video equipment or the equipment in the Digital Media Studio is required. May be repeated twice for credit. This course has the option of a letter grade or pass/no pass. This course is also listed as ART 140 and DM 140.

10900		ONLINE	Beede R	1.0			
You must have an email account to take this course. Start your course by going to www.gavilan.edu/disted . Unless you have made prior arrangements with the instructor, you MUST log on by 11:59 pm on the first day of the semester. Late adds must login within 24 hours of adding this course. If you miss the deadline you may be dropped. For help, contact your instructor or email disted@gavilan.edu .							

CSIS 178 Applied Networking

Transferable: CSU

This course covers fundamental networking concepts and develops the skills and knowledge to set up and maintain small business/home networks. The course is not hardware or vendor specific. It helps students prepare for the "Network +" certification exam, an industry-wide, vendor-neutral certification program developed and sponsored by the Computing Technology Industry Association (CompTIA). This course has the option of a letter grade or pass/no pass. May be repeated three times for credit. ADVISORY: CSIS 124

10258	L/L	PB5	Robinson V	4.0	4.0	S	0900-0100
-------	-----	-----	------------	-----	-----	---	-----------

CSIS 181 PC Hardware

Transferable: CSU

This course examines computing hardware, operating systems, and software applications from a technical side to enable students to select, install, maintain and optimize a computer system. This course will help prepare students to pursue the A+ Hardware Certification. This course has the option of a letter grade or pass/no pass. ADVISORY: CSIS 124, CSIS 1 OR CSIS 2, or equivalent computer experience.

10271	Lab	PB5	Robinson V	3.0	4.0	R	0230-0530
	ARR		Robinson V	1.0			

BUSINESS/CSIS DEGREES & CERTIFICATES

- Accounting
- Bioinformatics
- Business Computer Applications
- Business Economics
- Computer Networking
- Computer Programming
- General Business
- General Office
- Medical Office
- Programming for the Internet
- Real Estate
- Scientific Programming
- UNIX Operating Systems
- Web Page Production Specialist



Consult the Gavilan Catalog for [complete](#) information or visit the website at www.gavilan.edu

CSIS 129

Presentation Graphics - MS Powerpoint

1 unit

Also listed as CMUN 129



Learn to Build and Maintain Computers

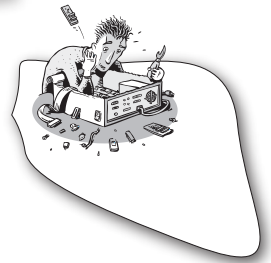

CSIS 178 APPLIED NETWORKING

CSIS 181 PC HARDWARE

CSIS 182 OPERATING SYSTEMS

PREPARATION FOR A+ CERTIFICATION EXAMS
(Get discounts on Exams)

CRN Type Room Instructor Hrs. Units Days Begin-End

CSIS 182 Operating Systems

Transferable: CSU

This course will survey current computer operating systems such as Microsoft Windows 98, NT, 2000 and XP. Linux will also be covered. Topics include file system management, systems requirements, network systems integration, security, and regular maintenance procedures. This course has the option of a letter grade or pass/no pass. ADVISORY: CSIS 1 or CSIS 2 or equivalent computer experience

10283	L/L	PB5	Robinson V	4.0	4.0	M	0600-0950
-------	-----	-----	------------	-----	-----	---	-----------

CSIS 183 Introduction to Microsoft Servers

Transferable: CSU

This course introduces students to the fundamentals of Microsoft Server setup and administration. Topics include managing file systems (including Active Directories), devices, user accounts, backups, and basic security. This course has the option of a letter grade or pass/no pass. May be repeated three times for credit. ADVISORY: CSIS 182.

10285	Lab	PB5	Robinson V	4.0	4.0	T	0600-0950
-------	-----	-----	------------	-----	-----	---	-----------

Check out *Classes offered at the satellite sites...*

Hollister classes - page 60. Morgan Hill classes - page 62.

CRN Type Room Instructor Hrs. Units Days Begin-End

CSIS 190 Occupational Work Experience/Computer Science

Transferable: CSU

College credit for learning experience obtained on the job in accordance with a training plan developed cooperatively between the employer, college and student. 75 hours per semester per unit or 60 hours per semester for unpaid experience. This is a pass/no pass course. May be taken for a maximum of 16 work experience units. REQUIRED: Declared vocational major. Concurrent enrollment in seven or more units (including CWE units, except for summer school. For summer school, enrollment in one other class is required). Minimum 2.00 G.P.A.

Mandatory course orientation for the following classed will be conducted Tuesday October 6, 2009 from 530 pm-630 pm the North/South Lounge, Wednesday, October 7, 2009 from 430 pm -530 pm in the North/South Lounge and Thursday October 8, 2009 from 8 am to 9 am in the North/South Lounge. Students need to attend one of the three meetings. Please contact Susan Sweeney, CWE Coordinator at (408) 848-4813 for more information.

10842	Wrk Ex	LI101A	Sweeney S	1.0		
10843	Wrk Ex	LI101A	Sweeney S	2.0		
10844	Wrk Ex	LI101A	Sweeney S	3.0		
10845	Wrk Ex	LI101A	Sweeney S	4.0		

CSIS 570 Computer Access Evaluation

Transferable: No

This course is intended to provide an in-depth computer access evaluation in order to determine an appropriate access environment for a student with a disability or multiple disabilities. This is a pass/no pass course. May be repeated as necessary based on measurable progress as documented in the Student Educational Contract. This is an open entry, open exit course. ADVISORY: This course is intended for students with a verified disability who show a need for the use of assistive computer programs and/or equipment or demonstrated academic deficit.

10528	Lab	LI105	Maringer J	.5	day/time - see instructor	
-------	-----	-------	------------	----	---------------------------	--

Make an appointment with the HTC instructor (LI105).

CSIS 571 Computer Assisted Instruction

Transferable: No

This course is an Assistive Computer Technology Lab designed for students who are eligible for Disability Services. The course is designed to improve basic academic skills and/or cognitive processes through the use of appropriate software or to learn assistive devices designed to make computers accessible. Course content is based on Student Educational Contracts which are developed for each student. This is a pass/no pass course. May be repeated as necessary based on measurable progress as documented in the Student Educational Contract. This is an open entry, open exit course. ADVISORY: This course is intended for students with a verified disability who show a need for the use of adaptive computer programs and/or equipment or demonstrated academic deficit.

10529	Lab	LI105	Maringer J	.5	day/time - see instructor	
Open Entry-Open Exit.						
10531	Lab	LI105	Maringer J	1.0	day/time - see instructor	
Open Entry-Open Exit.						
10535	Lab	LI105	Maringer J	2.0	day/time - see instructor	
Open Entry-Open Exit.						

CSIS 572 Adaptive Computer Basics

Transferable: No

This course will include an introduction to the basic concept of how computers work, using the computer keyboard, word processing, beginning Internet and presentation graphics. This course will be self-paced and adjusted so that students with disabilities can learn a number of adaptive devices designed to make computers accessible. This is a pass/no pass course. May be repeated as necessary based on measurable progress as documented in the Student Educational Contract. ADVISORY: This course is intended for students with a verified disability who show a need for the use of adaptive computer programs and/or equipment or demonstrated academic deficit.

10536	Lab	LI105	Maringer J	3.2	1.0 MW	1250-0210
-------	-----	-------	------------	-----	--------	-----------

Computerized Accounting: see ACCT 120
Construction: see Industrial Technology (IT)
Corrections: see Administration of Justice

CRN Type Room Instructor Hrs. Units Days Begin-End

COSMETOLOGY

COS 200 Beginning Cosmetology

Transferable: No

Fundamental principles of the science/art of beauty culture including hair design, chemical services and cosmetic therapy. May be repeated once for credit. ADVISORY: Eligible for English 250, 260 and Mathematics 205.

10804	L/L	PB9	Ramirez G	30.4	12.0	TWRF	0810-0330
-------	-----	-----	-----------	------	------	------	-----------

COS 201 Intermediate Cosmetology

Transferable: No

Extended studies and techniques in tinting, bleaching, permanent waving, shaping, styling, acrylic nail, pedicuring, chemical straightening, soft perming, waxing, care of skin and make-up. ADVISORY: Satisfactory completion of Cosmetology 200. Eligible for English 250, 260 and Mathematics 205.

10805	L/L	PB8	Hernandez R	30.4	12.0	TWRF	0810-0330
-------	-----	-----	-------------	------	------	------	-----------

COS 202 Advanced Cosmetology

Transferable: No

Advanced techniques in tinting, lightening, hair design and cosmetic chemistry. May be repeated once for credit. PREREQUISITE: Completion of COS 200 & 201. ADVISORY: Eligible for English 250, 260 and Mathematics 205.

10808	L/L	PB7	Andre M	15.2	12.0	TW	0810-0330
	L/L	PB7	Khanna N	15.2		RF	0810-0330

COS 203 Practicum

Transferable: No

Advanced techniques in tinting, lightening, hair and design and cosmetic chemistry. May be repeated once for credit. PREREQUISITE: Completion of COS 200, 201 and 202. ADVISORY: Eligible for English 250, 260 and Mathematics 205.

10809	L/L	PB8	Andre M	15.2	2.0	TW	0810-0330
	L/L	PB8	Khanna N	15.2		RF	0810-0330

COS 205 State Board Review

Transferable: No

State Board exam procedures and standards. ADVISORY: Cosmetology 201.

10870	Lab	PB8	Hernandez R	5.9	2.0	M	0810-0145
-------	-----	-----	-------------	-----	-----	---	-----------

COS 221 Advanced Scientific Skin Care (Esthetics)

Transferable: No

An advanced in-depth study and training in the care and treatment of skin, cosmetics and manipulative electrical modalities as required by the State Board of Cosmetology. PREREQUISITE: Completion of COS 220 or equivalent.

10869	L/L	PB9B	Juarez A Gomez D	20.0	8.0	MTWRF	0500-0900
-------	-----	------	---------------------	------	-----	-------	-----------

COS 290 Occupational Work Experience/Cosmetology

Transferable: No

College credit for learning experience obtained on the job in accordance with a training plan developed cooperatively between the employer, college and student. 75 hours per semester per unit or 60 hours per semester for unpaid experience. This is a pass/no pass course. May be taken for a maximum of 16 work experience units. REQUIRED: Declared vocational major. Concurrent enrollment in seven or more units (including CWE units, except for summer school. For summer school, enrollment in one other class is required). Minimum 2.00 G.P.A.

Mandatory course orientation for the following classed will be conducted Tuesday October 6, 2009 from 530 pm-630 pm the North/South Lounge, Wednesday, October 7, 2009 from 430 pm -530 pm in the North/South Lounge and Thursday October 8, 2009 from 8 am to 9 am in the North/South Lounge. Students need to attend one of the three meetings. Please contact Susan Sweeney, CWE Coordinator at (408) 848-4813 for more information.

10871	Wrk Ex	LI101A	Sweeney S	1.0		
10872	Wrk Ex	LI101A	Sweeney S	2.0		
10873	Wrk Ex	LI101A	Sweeney S	3.0		
10874	Wrk Ex	LI101A	Sweeney S	4.0		

Classroom Locations: Refer to "How to Use This Schedule" on page 5.

CRN Type Room Instructor Hrs. Units Days Begin-End

CPR: see Allied Health
Desktop Publishing: see CSIS or DM

DIGITAL MEDIA

DM 6 Web Page Authoring I

Transferable: CSU; GAV-GE:E2

An introduction to using Hypertext Mark-Up Language (HTML) and Extensible HTML (XHTML) to create web pages which can be uploaded and displayed on the World Wide Web. Students will use HTML/XHTML to create web pages with text in various sizes and colors, links to other sites, background color or patterns, graphics, tables and mailto links. Principles of design and color as they apply to screen presentations will be included. This course has the option of a letter grade or pass/no pass. May be repeated three times for credit. Also listed as CSIS 6 and LIB 6. ADVISORY: CSIS 1 or CSIS 2 or CSIS 3/LIB 3 advised.

10315 Online ONLINE Howell J 2.0
 09/03/09 - 10/26/09 You must have an email account to take this course. Start your course by going to www.gavilan.edu/disted. Unless you have made prior arrangements with the instructor, you MUST log on by 11:59 pm on the first day of class. Late adds must login within 24 hours of adding this course. If you miss the deadline you may be dropped. For help, contact your instructor or email disted@gavilan.edu.

10318 Online ONLINE Howell J 2.0
 10/19/09 - 12/12/09 You must have an email account to take this course. Start your course by going to www.gavilan.edu/disted. Unless you have made prior arrangements with the instructor, you MUST log on by 11:59 pm on the first day of class. Late adds must login within 24 hours of adding this course. If you miss the deadline you may be dropped. For help, contact your instructor or email disted@gavilan.edu.

DM 60 3D Animation I

Transferable: CSU

Fundamentals and aesthetics of digital 3D animation, including modeling, animation and rendering. Focus on computer animation tools and techniques including workflow and storyboarding. Builds a solid foundation for developing character animation, architecture walkthroughs, and special-effect sequences. This course has the option of a letter grade or pass/no pass. May be repeated once for credit. ADVISORY: Any of the following: DM 77, DM 75, DM 76, DM 110, CGD 2, ART 48A, ART 48B, or equivalent.

10331 L/L LI128 Brownkorb R 3.0 3.0 F 0945-1240

DM 61 3D Animation II

Transferable: CSU

This class extends animation into character modeling, soundtrack synchronization, advanced shading, lighting, rendering and compositing techniques. May include topics such as particles, dynamics, and scripting. This course has the option of a letter grade or pass/no pass. ADVISORY: DM 60 or equivalent experience.

10332 L/L LI128 Brownkorb R 3.2 3.0 TR 1250-0210

DM 74 Advanced Photoshop

Transferable: CSU; GAV-GE:C1

This course is for the PhotoShop-experienced student and explores PhotoShop's advanced features in depth. Students work on projects, which challenge their creativity and technical ability, and will be encouraged to develop complex projects for the web and for the printed page. May be repeated three times for credit. This course has the option of a letter grade or pass/no pass. This course is also listed as ART 74 and CSIS 74. ADVISORY: CSIS 75 PhotoShop I

10321 Lec MHG5 Grzan R 3.3 3.0 R 0630-0935
 Above class meets at Morgan Hill Community site.

DM 75 PhotoShop I - Adobe PhotoShop

Transferable: CSU; GAV-GE:C1

This course is based on the software application Adobe PhotoShop. Students learn to scan photographs and manipulate them using PhotoShop tool box and special effects filters. They will learn to correct photos; mask image using channels; create duotone, tritone, and quadtone images; prepare photos for use in printing and on the web. This course has the option of a letter grade or pass/no pass. May be repeated three times for credit. Students who repeat this course will learn new and advanced features. This course is also listed as CSIS 75. ADVISORY: CSIS 124 (Windows Fundamentals), CSIS 2L

10905 L/L LI128 Powers K 3.3 3.0 M 0330-0635

10906 L/L MHG5 Grzan R 3.3 3.0 T 0630-0935
 Above class meets at Morgan Hill Community site.

DM 60, 61 3-D ANIMATION I, II

Learn Maya 3D animation!
 Make your own cartoons, websites, videos!

Transfers to CSU
 Use for GAV-GE: Area C1

SEE YOUR FUTURE IN



- You can:
- Make a web site for CyberSpace
 - Produce a video for GavTV or YouTube
 - Record you Podcast for the Internet
 - Animate your story or game idea
 - Design graphics for web, TV or print
 - Shoot and edit digital photographs

- Take:
- DM 77 Intro. to Digital Media
 - DM 60, 61, 3D Animation I & II
 - DM 80 Digital Photography
 - DM 75, 74 Photoshop I & II
 - DM 110 Interactive Animation: Flash
 - DM 113 Introduction to Digital Video
 - DM 114 Digital Media Production
 - DM 140 Basic Digital Film/Video Production

CRN Type Room Instructor Hrs. Units Days Begin-End

DM 77 Introduction to Digital Media and its Tools

Transferable: CSU, UC; GAV-GE:C1

An introduction to the field of digital media, including history, social impact, concepts, career options and industry trends. Applying learned visual and aural design principles, students will explore the use of computer-based tools in the design and production of digital media by creating and editing digital images, sounds, video, animation, and text. A comprehensive term project for publication on the web or CD ROM will be required. This course is also listed as ART 77 and CSIS 77. This course has the option of a letter grade or pass/no pass. May be repeated twice for credit. ADVISORY: CSIS 124, CSIS 1, CSIS 2/2L, CSIS 3, or familiarity using the Macintosh or Windows operating system.

10913 L/L LI128 Beede R 3.2 3.0 TR 0945-1105

10887 L/L MHG5 Mullins A 3.3 3.0 W 0600-0905
 Above class meets at Morgan Hill Community site.

DM 80 Digital Photography

Transferable: CSU, UC; GAV-GE:C1

The study of digital photography from digital camera to the computer-based printer or digital media. Artistic, theoretical, and technical aspects will be considered. Topics include information about types and purchasing of digital cameras; theory, mechanics, and art of digital imagery; digital darkroom; eccentricities of digital photo taking; stitching photos for virtual reality; and preparing digital images for print, World Wide Web and other digital media. This course has the option of a letter grade or pass/no pass. This course is also listed as ART 80 and CSIS 80. ADVISORY: CSIS 1 or CSIS 2/2L or ART 8A or equivalent computer experience.

10926 L/L LI128 Edberg J 5.4 3.0 MW 1250-0315

CRN Type Room Instructor Hrs. Units Days Begin-End

DM 85 Web Design I: Dreamweaver

Transferable: CSU; GAV-GE:C1

Basic and intermediate principles of designing Web pages/sites using the Dreamweaver web design software and HTML. Emphasis will be on good design and the use of tables, frames, forms, rollovers, DHTML, XHTML, behaviors, and CSS. Also includes site maintenance and the integration of multimedia components such as graphics, sound, animation, and video. This course is for the content person to design, develop, and maintain effective Web sites. This course is also listed as ART 85 and CSIS 85. This course has the option of a letter grade or pass/no pass. May be repeated twice for credit. ADVISORY: CSIS 6 or basic knowledge of HTML.

10335 ONLINE Lawrence S 2.0
 10/14/09-12/18/09 You must have an email account to take this course. Start your course by going to www.gavilan.edu/disted. Unless you have made prior arrangements with the instructor, you MUST log on by 11:59 pm on the first day of the semester. Late adds must login within 24 hours of adding this course. If you miss the deadline you may be dropped. For help, contact your instructor or email disted@gavilan.edu.

10910 Lec HOL3 Lee K 3.3 2.0 M 0230-0535
 Above class meets at the Hollister Briggs site.

DM 107 Digital Media Design

Transferable: CSU

Fundamentals of design for visual, time-based, interactive, and sound arts as applied to digital media. Includes basic storytelling, graphic design, information architecture, and human factors. Page layout, scriptwriting, storyboards, and flow charts will be used as tools applicable to the design and development of business presentations, interactive media, educational multimedia, animation, web sites, video games, and film/video. This course has the option of a letter grade or pass/no pass. Also listed as ART 107 and CSIS 107. ADVISORY: CSIS 1 or CSIS 2/2L or equivalent computer experience

10911 L/L LI128 Fainshtein V 3.3 2.0 R 0330-0635

DM 108 Digital Media Lab

Transferable: CSU; GAV-GE:C1

Supervised practice and individualized computer assisted learning or software applications and techniques commonly found in the design and production of digital media (e.g., digital art and imaging, digital photography, digital print, digital audio/video, web design design/authoring, DVD/CD ROMs, animation). Supplements lecture courses. Open entry/exit, so may be added anytime during the semester. This is a pass/no pass course. Also listed as ART 108 and CSIS 108. May be repeated three times for credit. ADVISORY: CSIS 1 or CSIS 2/2L or equivalent computer experience.

10728 Lab LI128 Beede R .5
 10758 Lab LI128 Beede R 1.0

DM 110 Interactive Animation: Flash

Transferable: CSU; GAV-GE:C1

The production of vector graphics, animation, and interactive multimedia in Shockwave-Flash format for web pages and other digital media. Design of highly interactive web site interfaces and animated games using Flash actions (scripting). Useful for web designers/developers, animators, and multimedia authors. This course has the option of a letter grade or pass/no pass. Also listed as ART 110 and CSIS 110. May be repeated three times for credit. ADVISORY: CSIS 1, CSIS 2/2L, CSIS 124 or basic computer knowledge.

10895 L/L LI128 Beede R 3.2 3.0 MW 1120-1240

DM 113 Introduction to Digital Video

Transferable: CSU; GAV-GE:C1

Introduction to the aesthetic and technical aspects of digital video recording, non-linear editing, special effect generation, and production of video (and associated audio) using the personal computer equipped with specialized software such as iMovie, Final Cut Pro, and After Effects. Also considered will be the preparation of digital video for use in interactive media such as CD, DVD, and the World Wide Web. Students will produce a final digital video project on DVD. This course has the option of a letter grade or pass/no pass. May be repeated 2 times for credit. Also listed as ART 113 and CSIS 113. ADVISORY: CSIS 1 or CSIS 2/2L or equivalent computer experience

10898 L/L LI128 Beede R 3.2 3.0 MW 0945-1105

CRN Type Room Instructor Hrs. Units Days Begin-End

DM 114 Digital Media Production

Transferable: CSU

A team oriented practicum that focuses on the application of learned skills to the production of digital media and digital print projects, such as web sites, CD ROM, and DVDs. Project development will be accomplished according to team derived master schedules. Lectures will be on project management, work coordination and production techniques, client-team interface, asset management and integration, budget estimates, testing, and copyright infringement. Please note that this is very much a team oriented class. This course has the option of a letter grade or pass/no pass. This course is also listed as ART 114 and CSIS 114. ADVISORY: At least one of the following: ART 75, CGE 2, JOUR 18A, MUS 21, CSIS 7, CSIS 71, OR CSIS 77. or possess equivalent skills from any one of the following areas: digital media, computer graphics, digital print, film, TV/video, journalism (publishing), drawing or illustration, web design/development, business/marketing, or programming.

10912 Lec LI128 Beede R 3.2 2.0 TR 1120-1240

DM 140 Basic Digital Film/Video Production

Transferable: CSU, UC; GAV-GE:C1

An on-line self-paced course covering the basics of film/video production and post production (editing) using "easy to use" computer software such as Apple's iMovie. Beneficial for students who are producing a video/film project as a requirement for another college course, extra skills development, or for self interest. Completion of the associated class or personal project in DVD format using either personal video equipment or the equipment in the Digital Media Studio is required. May be repeated twice for credit. This course has the option of a letter grade or pass/no pass. This course is also listed as ART 140 and CSIS 140.

10901 ONLINE Beede R 1.0
 You must have an email account to take this course. Start your course by going to www.gavilan.edu/disted. Unless you have made prior arrangements with the instructor, you MUST log on by 11:59 pm on the first day of the semester. Late adds must login within 24 hours of adding this course. If you miss the deadline you may be dropped. For help, contact your instructor or email disted@gavilan.edu.

ECOLOGY

ECOL 1 Conservation of Natural Resources

Transferable: CSU, UC; CSU-GE:B2, B3, IGETC:5B; GAV-GE:B2, B3

This course examines the fundamentals of ecology (the study of the relationships between organisms and their environment) with special emphasis on human effects on the environment. Topics of discussion will include ecosystem dynamics, resources, pollution, population growth, and the clash between economic and political policy and the environment. ADVISORY: Eligible for English 250 and English 260.

10360 Lec LS101 Hubbard J 3.2 4.0 TR 1250-0210
 Lab LS101 Hubbard J 3.3 T 0230-0535
 10361 Lec LS101 Hubbard J 3.2 4.0 TR 1250-0210
 Lab LS101 Hubbard J 3.3 R 0230-0535

This service learning section involves community work. See page 64 for details.

ECONOMICS

ECON 1 Principles of Macroeconomics

Transferable: CSU, UC; CSU-GE:D2, IGETC:4B; GAV-GE:D2; CAN:ECON2

Introduction to the principles of macroeconomics, social organization of the economy; supply and demand; the determinants of national income and production, economic growth, the global economy and trade, employment, prices, savings and investment; the nature and effectiveness of monetary and fiscal policy. This course has the option of a letter grade or pass/no pass. ADVISORY: Eligible for English 1A and Mathematics 233.

10892 Lec HOL1 Sandoval-Herna 3.3 3.0 F 0945-1250
 Above class meets at the Hollister Briggs site.
 10924 Lec PB13 Truongson B 3.2 3.0 TR 1120-1240
 10890 Lec MHG5 Shokou A 3.3 3.0 M 0600-0905
 Above class meets at Morgan Hill Community site.

10923 ONLINE Truongson B 3.0
 You must have an email account to take this course. Start your course by going to www.gavilan.edu/disted. Unless you have made prior arrangements with the instructor, you MUST log on by 11:59 pm on the first day of the semester. Late adds must login within 24 hours of adding this course. If you miss the deadline you may be dropped. For help, contact your instructor or email disted@gavilan.edu.

CRN Type Room Instructor Hrs. Units Days Begin-End

ECON 2 Principles of Microeconomics

Transferable: CSU, UC; CSU-GE:D2, IGETC:4B; GAV-GE:D2; CAN:ECON4

Introduction to microeconomic principles and theory; supply, demand; product and factor price determination, resource allocation, costs, revenues, and profits under different competitive situations; international trade; government regulation and taxation. Note: Economics 1 is not a prerequisite for Economics 2. This course has the option of a letter grade or pass/no pass. **ADVISORY:** Eligible for English 260, English 250 and Mathematics 233.

10946	Lec	PB5	Truongson B	3.6	3.0	TR	1250-0220
10891	Lec	HU102	Shokou A	3.3	3.0	T	0600-0905

Education: see Child Development

ENGLISH

ENGL 1A Composition

Transferable: CSU, UC; CSU-GE:A2, IGETC:1A; GAV-GE:A2; CAN:ENGL2, ENGL SEQ A

This is a writing course which emphasizes expository writing, argumentative writing, and critical reading of expository prose. It is meant to train students in clear thinking and reasoned support of ideas. Students will be given the opportunity to read models of good expository and argumentative prose and learn the techniques of good writing. These include choosing appropriate subjects, developing restricted, unified, and precise theses and presenting supporting evidence in a logical, lucid, and effective manner. To achieve this end, students write no fewer than six essays and read at least five works, two of which are book length. **PREREQUISITE:** English 250 and English 260 or English 250 and SSCI 270A or English 250 and SSCI 270B with a grade of 'C' or better or satisfactory score on the English placement examination.

10107	Lec	HU103	Pirani A	3.2	3.0	MW	0810-0930	
10108	Lec	MHG3	Bragger M	3.2	3.0	MW	0810-0930 Above class meets at Morgan Hill Community site.	
10111	Lec	SS203	Allison M	3.3	3.0	F	0900-1205	
10124	Lec	HOL5	Mora G	3.3	3.0	F	0900-1205 Above class meets at the Hollister Briggs site.	
10110	Lec	SS203	Condon D	3.2	3.0	TR	0945-1105	
10109	Lec	PH102	Mora G	3.2	3.0	MW	1120-1240	
12	10112	Lec	HOL5	Salvin C	3.2	3.0	TR	1120-1240 Above class meets at the Hollister Briggs site.
10113	Lec	SS111	Osikomaiya J	3.2	3.0	MW	1250-0210	
13	10114	Lec	SS111	Hirasuna S	3.2	3.0	TR	1250-0210
10115	Lec	HU103	Osikomaiya J	3.2	3.0	MW	0230-0350	
10116	Lec	HU103	Allison M	3.2	3.0	TR	0400-0520	
5	10120	Lec	HOL1	Brett T	3.3	3.0	W	0600-0905 Above class meets at the Hollister Briggs site.
10122	Lec	HU103	Pirani A	3.3	3.0	R	0600-0905	
10119	Lec	MHG11	Kovacs M	3.3	3.0	M	0630-0935 Above class meets at Morgan Hill Community site.	
10123	Lec	HU102	Jahan H	3.3	3.0	M	0600-0905	

2 10117 ONLINE Luoma D 3.0
You must have an email account to take this course. Start your course by going to www.gavilan.edu/disted. Unless you have made prior arrangements with the instructor, you MUST log on by 11:59 pm on the first day of the semester. Late adds must login within 24 hours of adding this course. If you miss the deadline you may be dropped. For help, contact your instructor or email disted@gavilan.edu.

10118 ONLINE Chaffin C 3.0
You must have an email account to take this course. Start your course by going to www.gavilan.edu/disted. Unless you have made prior arrangements with the instructor, you MUST log on by 11:59 pm on the first day of the semester. Late adds must login within 24 hours of adding this course. If you miss the deadline you may be dropped. For help, contact your instructor or email disted@gavilan.edu.

10121 ONLINE Crook E 3.0
You must have an email account to take this course. Start your course by going to www.gavilan.edu/disted. Unless you have made prior arrangements with the instructor, you MUST log on by 11:59 pm on the first day of the semester. Late adds must login within 24 hours of adding this course. If you miss the deadline you may be dropped. For help, contact your instructor or email disted@gavilan.edu.

Choose a **THEME** for your English class:

Find the number, by the course section number, that corresponds to a theme below.

- 1 Explore American consumerism and wild alternatives.
- 2 Explore the great American classics.
- 3 Explore diversity, equality, and tolerance in the Freedom Writer's Diary and American life today.
- 4 Explore the great literature of the human condition, challenging you to respond to literary art, science fiction, music, tragedy and the joy of life and living.
- 5 Explore the exciting realm of science and discover who we are, how we got here, and learn about the scientists and explorers who got us here while learning to write with panache, flair and accuracy.
- 6 Learn to think, to think courageously, to think intelligently and to think for yourself through challenging the pseudoscientific, the paranormal, the make-believe world of nutty beliefs and scams.
- 7 First Year Experience: Use what we discover through our brains, bodies and spirits to create, in a classroom where we practice thinking like scientists, literary critics and artists.
- 8 Take a different look at the wars we all think we know, through the literature and personal accounts of writers such as John Steinbeck, Eve Ensler and Lousi DeBernais.
- 9 Learning Community: Explore the theme of Nurturing Childhood in a dynamic, supportive learning environment using writing, discussion, and discovery to identify nurturance as an important part of family life and community action.
- 10 First Year Experience: Explore the issues of Peace and Conflict through reading and writing.
- 11 Puente: Develop writing skills through an emphasis on Chicano/Latino literature.
- 12 Investigate environmental issues, particularly those connected to what we eat and where we live.
- 13 Develop expository writing skills in response to literary works from a rich diversity of American cultures.
- 14 Read and write in a class of Fantasy and Folklore.



The Puente Project is a two-semester program that combines three components: writing, counseling and mentoring to support students to transfer to four-year universities and colleges. The Guidance 1 course focuses on self assessment and career development. The English 250 course focuses on Mexican American/Latino literature. The program also includes a student leadership conference, university visits and mentor/student socials. The program is open to all eligible students. For more information, call Celia Marquez, Puente Co-Coordinator at 408-848-4807.

Required: Complete a program application with the Puente Counselor prior to registration. Students must attend a mandatory Puente Welcome on Wednesday, August 26, from 8:30 am - 1 pm in SS206.

GUID 1 CRN 10819 LS106 Marquez C MW 1120A-1240P
Students will need to complete 10 hours of mentoring.

Choose one of the ENGL 250 courses listed below:

ENGL 250	CRN 10158	PH102	Sandler S	TuTh	1120A -1240P
		LI120	Sandler S	T	1255P - 0145P
ENGL 250	CRN 10159	PH102	Sandler S	TR	1120A - 1240P
		LI120	Sandler S	R	1255P - 0145P

CRN Type Room Instructor Hrs. Units Days Begin-End

ENGL 1B Composition and Literature

Transferable: CSU, UC; CSU-GE:C, IGETC:3B; GAV-GE:C2; CAN:ENGL4, ENGL SEQ A

English 1B continues the work begun in 1A, but now the emphasis shifts to writing expository prose in conjunction with reading and analyzing imaginative literature. Students are to write as fledgling critics and use the text as a basis for other forms of reflection. The reading requirement includes short stories, poetry, drama, and at least two novels. Course work will also include fundamentals of research writing. PREREQUISITE: English 1A with a grade of "C" or better.

10128	Lec	HU103	Jahan H	3.3	3.0	F	0900-1205
10127	Lec	HU103	Crook E	3.2	3.0	TR	0945-1105
10129	Lec	SS111	Richards G	3.2	3.0	TR	1120-1240
10130	Lec	SS203	Oral M	3.2	3.0	MW	1250-0210
10131	Lec	HU102	Jahan H	3.2	3.0	MW	0230-0350
10133	Lec	HOL4	Mora G	3.2	3.0	MW	0400-0520 Above class meets at the Hollister Briggs site.
10132	Lec	HU102	Brett T	3.3	3.0	R	0600-0905
10125	ONLINE		Raimondo J	3.0			
<p>You must have an email account to take this course. Start your course by going to www.gavilan.edu/disted. Unless you have made prior arrangements with the instructor, you MUST log on by 11:59 pm on the first day of the semester. Late adds must login within 24 hours of adding this course. If you miss the deadline you may be dropped. For help, contact your instructor or email disted@gavilan.edu.</p>							
10126	ONLINE		Warren K	3.0			
<p>You must have an email account to take this course. Start your course by going to www.gavilan.edu/disted. Unless you have made prior arrangements with the instructor, you MUST log on by 11:59 pm on the first day of the semester. Late adds must login within 24 hours of adding this course. If you miss the deadline you may be dropped. For help, contact your instructor or email disted@gavilan.edu.</p>							
10134	ONLINE		Raimondo J	3.0			
<p>You must have an email account to take this course. Start your course by going to www.gavilan.edu/disted. Unless you have made prior arrangements with the instructor, you MUST log on by 11:59 pm on the first day of the semester. Late adds must login within 24 hours of adding this course. If you miss the deadline you may be dropped. For help, contact your instructor or email disted@gavilan.edu.</p>							

Be Aware

You MAY NOT take courses that overlap (courses that meet at the same day and time)!

CRN Type Room Instructor Hrs. Units Days Begin-End

ENGL 1C Critical Reasoning and Writing

Transferable: CSU, UC; CSU-GE:A3, IGETC:1B; GAV-GE:C2

This course is designed to develop critical thinking, reading, and writing skills beyond the level achieved in English 1A. The emphasis is on critical analysis of arguments and the development of the ability to integrate the principles of critical thinking into essay writing. PREREQUISITE: English 1A with a grade of "C" or better.

10136	Lec	SS203	Condon D	3.2	3.0	TR	0810-0930
10137	Lec	MHG11	Luoma D	3.2	3.0	MW	1120-1240 Above class meets at Morgan Hill Community site.
10138	Lec	HU102	Luoma D	3.2	3.0	TR	0400-0520
10139	Lec	SS203	Brett T	3.3	3.0	M	0600-0905
10135	ONLINE		Chaffin C	3.0			
<p>You must have an email account to take this course. Start your course by going to www.gavilan.edu/disted. Unless you have made prior arrangements with the instructor, you MUST log on by 11:59 pm on the first day of the semester. Late adds must login within 24 hours of adding this course. If you miss the deadline you may be dropped. For help, contact your instructor or email disted@gavilan.edu.</p>							
10140	ONLINE		Allison M	3.0			
<p>You must have an email account to take this course. Start your course by going to www.gavilan.edu/disted. Unless you have made prior arrangements with the instructor, you MUST log on by 11:59 pm on the first day of the semester. Late adds must login within 24 hours of adding this course. If you miss the deadline you may be dropped. For help, contact your instructor or email disted@gavilan.edu.</p>							

ENGL 2C Introduction to Film and Fiction

Transferable: CSU, UC; CSU-GE:C2, IGETC:3B; GAV-GE:C2

This is a literature course in analysis of the novel and film as art forms. The student will read several novels, view the films based on the novels, and discuss the difference in techniques, both orally and in writing. PREREQUISITE: Eligible for English 1A.

10197	Lec	SS214	Richards G	3.3	3.0	W	0630-0935
-------	-----	-------	------------	-----	-----	---	-----------

ENGL 2E Introduction to Women Writers

Transferable: CSU, UC; CSU-GE:C2, IGETC:3B; GAV-GE:C2, F

This is a transfer literature class which examines the history of women as writers and distinguishes themes in women's literature using the tools of literary criticism. PREREQUISITE: Eligible for English 1A.

10240	Lec	SS111	Salvin C	3.2	3.0	MW	1120-1240
-------	-----	-------	----------	-----	-----	----	-----------

1
2
3 Your ENGL 1B class has a theme. See list on page 91.

1
2
3 Your ENGL 1C class has a theme. See list on page 91.

Have you met the prerequisite?
It's required!

English 9A, B, C

CREATIVE Writing



Instructor: Karen Warren received her BA & MA at San Francisco State University.

"I love watching my students get engaged as writers and thinkers," says Karen Warren. "I know how much many of them sacrifice to get an education, and I'm privileged to help make it possible." Ms. Warren has taught English at Gavilan College for the past thirteen years and previously at Cabrillo College and the University of California Santa Cruz. Since graduation from the Creative Writing program at San Francisco State University, Karen has written plays, poetry, fiction, and memoir. She also enjoys creating digital stories with photographs, video, and audio components.

This class fulfills your CSU humanities transfer requirement.



Instructor: Michael Kovacs received his B.A. in English from UC, Berkeley, and his M.A. in English with an emphasis in American literature from Stanford University.

Michael is from the Bay Area, and currently lives in San Jose, CA and New Mexico. He has published and presented papers on the Beat Generation writer Jack Kerouac and Fresno-based writer William Saroyan. Michael is currently writing a personal memoir.

CRN Type Room Instructor Hrs. Units Days Begin-End

ENGL 5A Survey of American Literature - 1620 to 1865

Transferable: CSU; UC; CSU-GE: C2; IGETC: 3B; GAV-GE: C2; CAN: ENGL 14, ENGL SEQ. C
This course is a study of the masters of American literature covering the years 1620 to 1865 A.D. **PREREQUISITE:** Eligible for English 1A.

10228 ONLINE Sandler S 3.0

You must have an email account to take this course. Start your course by going to www.gavilan.edu/disted. Unless you have made prior arrangements with the instructor, you **MUST** log on by 11:59 pm on the first day of the semester. Late adds must login within 24 hours of adding this course. If you miss the deadline you may be dropped. For help, contact your instructor or email disted@gavilan.edu.

ENGL 9A Introduction to Creative Writing

Transferable: CSU, UC; CSU-GE:C2; GAV-GE:C2; CAN:ENGL6

This course includes the writing, reading, and critical discussions of various forms of poetry and fiction. **PREREQUISITE:** Eligible for English 1A.

10229 Lec SS216 Warren K 3.2 3.0 TR 1120-1240

10230 Lec HU102 Kovacs M 3.3 3.0 W 0600-0905

ENGL 9B Advanced Creative Writing

Transferable: CSU, UC; CSU-GE:C2; GAV-GE:C2

This class is a continuation of English 9A, with the emphasis shifting to publication. The genre of non-fiction will be the primary focus, but the genres of fiction will also be taught at a more comprehensive level than in English 9A. The process of finding a market for one's work will be followed step by step. The class may compile and publish "Soaring", Gavilan's literary magazine, each spring semester. **PREREQUISITE:** English 9A with a grade of credit or C or better.

10231 Lec SS216 Warren K 3.2 3.0 TR 1120-1240

10232 Lec HU102 Kovacs M 3.3 3.0 W 0600-0905

ENGL 9C Poetry Writing

Transferable: CSU, UC; CSU-GE:C2; GAV-GE:C2

This course includes the writing, reading, and critical discussions of various forms of poetry. **PREREQUISITE:** English 9A with a grade of credit or C or better.

10233 Lec SS216 Warren K 3.2 3.0 TR 1120-1240

10234 Lec HU102 Kovacs M 3.3 3.0 W 0600-0905

ENGL 12A Tutoring Writers: Training/Theory & Practice

Transferable: CSU

Fundamentals of compositional theory, the writing process, peer-to-peer communication, interacting with faculty and educational institutions and effective responses to writing will be covered. In addition, students will gain an understanding of the basic history, methodology and practice of writing pedagogy while developing a writing community that aids in connecting them to their own writing practice. **ADVISORY:** Eligible for English 1A.

Required: Students enrolling in CRN below must attend an intensive week-long seminar the week prior to the start of fall semester:

08/24/09 - 08/27/09 LI120 Smith K MTWR 0930-0230

10098 Lec LI120 Smith K 2.3 3.0 M 0230-0435

ENGL 12B Tutoring Writers: Training/Theory & Practice

Transferable: CSU

Fundamentals of compositional theory, the writing process, peer-to-peer communication, interacting with faculty and educational institutions and effective responses to writing will be covered. In addition, students will gain an understanding of the basic history, methodology and practice of writing pedagogy while developing a writing community that aids in connecting them to their own writing practice. **ADVISORY:** Eligible for English 1A.

Required: Students enrolling in CRNs below must attend an intensive week-long seminar the week prior to the start of fall semester:

08/24/09 - 08/27/09 LI120 Smith K MTWR 0930-0230

10141 Lec LI120 Smith K 1.3 2.0 M 0230-0335

10100 Lec LI120 Smith K 2.3 3.0 M 0230-0435

Discover
women's
literature from
around the
globe!

CRN #10240
Monday/Wednesday
11:20 am - 12:40 pm
Instructor -Christina Salvin

ENGL 2E

Introduction to Women Writers



Satisfies the humanities requirement under the IGETC, the CSU-GE Breadth and the AA/AS Degree patterns.

Introduction to Film & Fiction

ENGL 2C



CRN #10197
Wednesday
6:30 pm - 9:35 pm
Instructor - Grant Richards

The DaVinci Code
Pride and Prejudice
Million Dollar Baby
Mystic River
A History of Violence
Cold Mountain
Sideways
Motorcycle Diaries
Closer
Fight Club
Notebook
High Fidelity
The Shawshank Redemption
To Kill a Mockingbird
One Flew Over the Cuckoo's Nest
Chocolat
LA Confidential
Get Shorty
and more!

This class can fulfill your IGETC humanities transfer requirement.



Satisfies the humanities requirement under the IGETC, the CSU-GE Breadth and the AA/AS Degree patterns.

Offered 

ENGL 5A Survey of American Literature

CRN 10228
with Scott Sandler

CRN Type Room Instructor Hrs. Units Days Begin-End

ENGL 12C Tutoring Writers: Training/Theory & Practice

Transferable: CSU

Fundamentals of compositional theory, the writing process, peer-to-peer communication, interacting with faculty and educational institutions and effective responses to writing will be covered. In addition, students will gain an understanding of the basic history, methodology and practice of writing pedagogy while developing a writing community that aids in connecting them to their own writing practice. ADVISORY: Eligible for English 1A.

Required: Students enrolling in CRNs below must attend an intensive week-long seminar the week prior to the start of fall semester:

08/24/09 - 08/27/09	LI120	Smith K	MTWR	0930-0230
10102 Lec	LI120	Smith K	1.3 2.0 M	0230-0335
10103 Lec	LI120	Smith K	2.3 3.0 M	0230-0435

ENGL 12D Tutoring Writers: Training, Theory & Practice

Transferable: CSU

Fundamentals of compositional theory, the writing process, peer-to-peer communication, interacting with faculty and educational institutions and effective responses to writing will be covered. In addition, students will gain an understanding of the basic history, methodology and practice of writing pedagogy while developing a writing community that aids in connecting them to their own writing practice. ADVISORY: Eligible for English 1A.

Required: Students enrolling in CRNs below must attend an intensive week-long seminar the week prior to the start of fall semester:

08/24/09 - 08/27/09	LI120	Smith K	MTWR	0930-0230
10105 Lec	LI120	Smith K	1.3 2.0 M	0230-0335
10106 Lec	LI120	Smith K	2.3 3.0 M	0230-0435

ENGL 23 Independent Study

Transferable: CSU

Designed to afford selected students specialized opportunities for exploring areas at the independent study level. The courses may involve extensive library work, research in the community, or special projects. May be repeated until six units of credit are accrued. This course has the option of a letter grade or pass/no pass. REQUIRED: The study outline prepared by the student and the instructor must be filed with the department and the dean.

10142 IND	LI119	Smith K	1.0
10144 IND	SS109	Warren K	1.0
10143 IND	LI119	Smith K	2.0

CRN Type Room Instructor Hrs. Units Days Begin-End

ENGL 250 Practical Writing

Transferable: No; GAV-GE:A2

This course covers writing clear, correct, effective essays and learning preliminary research skills. PREREQUISITE: English 440 or ESL 563 with a grade of 'C' or better or satisfactory score on the English placement examination.

1 2 3 Your ENGL 250 class has a theme. See list on page 91.

10145 Lec	HU102	Oral M	3.2 3.0	MW	0810-0930
Lab	LI171	Oral M	1.0	M	0945-1035
10146 Lec	HU102	Oral M	3.2 3.0	MW	0810-0930
Lab	LI171	Oral M	1.0	W	0945-1035
10147 Lec	HU102	STAFF S	3.2 3.0	TR	0810-0930
Lab	LI171	STAFF S	1.0	F	0810-0900
10148 Lec	HU102	STAFF S	3.2 3.0	TR	0810-0930
Lab	LI171	STAFF S	1.0	F	0910-1000
10151 Lec	HU102	Salvin C	3.2 3.0	MW	0945-1105
Lab	LI120	Salvin C	1.0	M	0845-0935
10152 Lec	HU102	Salvin C	3.2 3.0	MW	0945-1105
Lab	LI120	Salvin C	1.0	W	0845-0935
10153 Lec	HOL5	Salvin C	3.2 3.0	TR	0945-1105
Lab	HOL3	Salvin C	1.0	T	0845-0935
Above class meets at the Hollister Briggs site.					
10154 Lec	HOL5	Salvin C	3.2 3.0	TR	0945-1105
Lab	HOL3	Salvin C	1.0	R	0845-0935
Above class meets at the Hollister Briggs site.					
10155 Lec	HU102	STAFF S	3.2 3.0	TR	0945-1105
Lab	LI171	STAFF S	1.0	F	1010-1100
10157 Lec	HU102	STAFF S	3.2 3.0	TR	0945-1105
Lab	LI171	STAFF S	1.0	F	1110-1200
10160 Lec	HU103	White S	3.2 3.0	MW	1250-0210
Lab	LI171	White S	1.0	F	1210-0100
10162 Lec	HU103	White S	3.2 3.0	MW	1250-0210
Lab	LI171	White S	1.0	F	0110-0200

continued

Be Aware

You MAY NOT take courses that overlap (courses that meet at the same day and time)!

ENGLISH COMPOSITION AND READING COURSE SEQUENCE

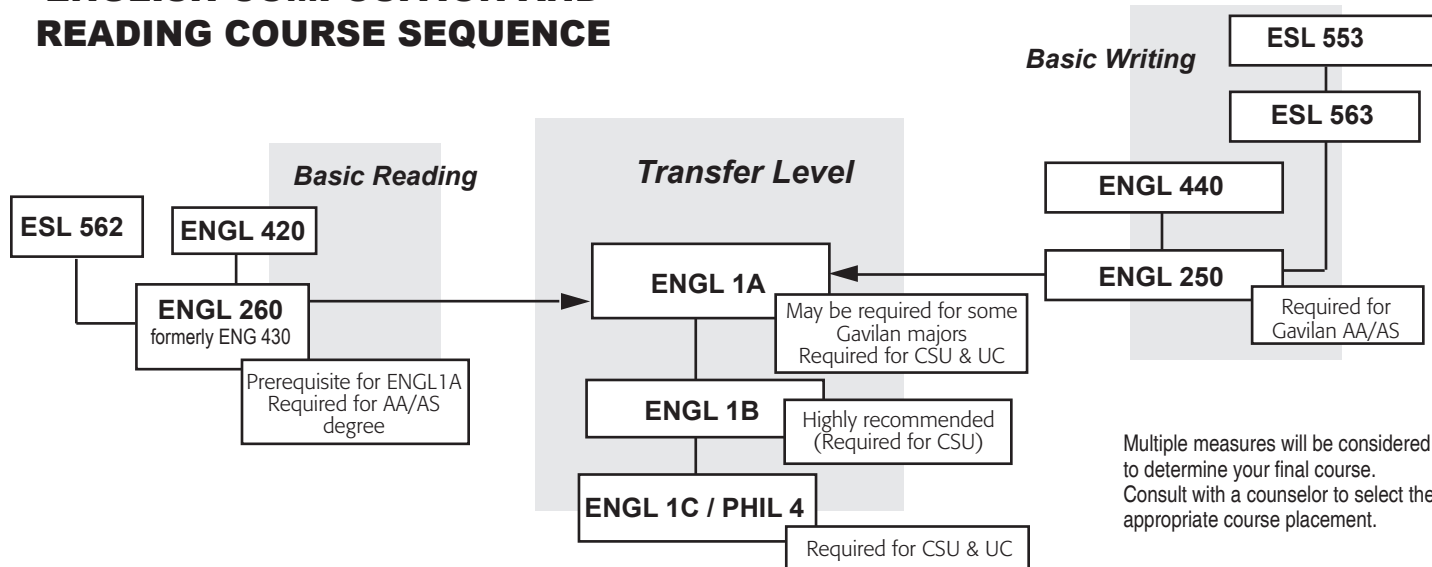

CRN	Type	Room	Instructor	Hrs.	Units	Days	Begin-End
10166	Lec	HU102	Hooper J	3.2	3.0	TR	0230-0350
	Lab	LI120	Hooper J	1.0		T	0400-0450
10168	Lec	HU102	Hooper J	3.2	3.0	TR	0230-0350
	Lab	LI120	Hooper J	1.0		R	0400-0450
10164	Lec	SS203	Estrada-Mack T	3.2	3.0	MW	0400-0520
	Lab	LI120	Estrada-Mack T	1.0		M	0530-0620
10165	Lec	SS203	Estrada-Mack T	3.2	3.0	MW	0400-0520
	Lab	LI120	Estrada-Mack T	1.0		W	0530-0620
10169	Lec	HU103	Arora S	3.2	3.0	MW	0700-0820
	Lab	LI120	Arora S	1.0		M	0830-0920
10170	Lec	HU103	Arora S	3.2	3.0	MW	0700-0820
	Lab	LI120	Arora S	1.0		W	0830-0920
10173	Lec	MHG12	STAFF S	3.2	3.0	TR	0700-0820
	Lab	MHG12	STAFF S	1.0		T	0830-0920
Above class meets at Morgan Hill Community site.							
10175	Lec	MHG12	STAFF S	3.2	3.0	TR	0700-0820
	Lab	MHG12	STAFF S	1.0		R	0830-0920
Above class meets at Morgan Hill Community site.							

LATE START ENGL 250 CLASSES:

10936	Lec	SS111	Gatewood J	6.8	3.0	TR	0230-0540
	Lab	LI120	Gatewood J	2.0		F	0100-0250
10/26/09 - 12/19/09 Above late-start class meets for eight weeks during the second half of the semester.							
10937	Lec	SS111	Gatewood J	6.8	3.0	TR	0230-0540
	Lab	LI120	Gatewood J	2.0		F	0300-0450
10/26/09 - 12/19/09 Above late-start class meets for eight weeks during the second half of the semester.							

LEARNING COMMUNITY ENGL 250 CLASSES:

10149	Lec	MHG4	Sandler S	3.2	3.0	TR	0910-1030
	Lab	MHG4	Sandler S	1.0		T	0810-0900
Above class meets at Morgan Hill Community site. This class is part of a Learning Community if you enroll you must also enroll in CD 5, CRN 10485.							
10150	Lec	MHG4	Sandler S	3.2	3.0	TR	0910-1030
	Lab	MHG4	Sandler S	1.0		R	0810-0900
Above class meets at Morgan Hill Community site. This class is part of a Learning Community if you enroll you must also enroll in CD 5, CRN 10485.							

FIRST YEAR EXPERIENCE ENGL 250 CLASSES:

10179	Lec	HU102	Hooper J	3.2	3.0	MW	1120-1240
	Lab	LI120	Hooper J	1.0		M	1010-1100
This class is part of a First Year Experience learning community. If you enroll you must also enroll in ENGL 260 CRN # 10189.							
10180	Lec	HU102	Hooper J	3.2	3.0	MW	1120-1240
	Lab	LI120	Hooper J	1.0		W	0230-0320
This class is part of a First Year Experience learning community. If you enroll you must also enroll in ENGL 260 CRN# 10921.							
10182	Lec	HU102	Smith K	3.2	3.0	TR	1250-0210
	Lab	LI120	Smith K	1.0		T	1010-1100
This class is part of a First Year Experience learning community. If you enroll you must also enroll in ENGL 260 CRN# 10190.							
10183	Lec	HU102	Smith K	3.2	3.0	TR	1250-0210
	Lab	LI120	Smith K	1.0		R	1010-1100
This class is part of a First Year Experience learning community. If you enroll you must also enroll in ENGL 260 CRN # 10922.							

PUEENTE LEARNING COMMUNITY ENGL 250 CLASSES:

10158	Lec	PH102	Sandler S	3.2	3.0	TR	1120-1240
	Lab	LI120	Sandler S	1.0		T	1255-0145
Students enrolled in this class will participate in the PUEENTE program and will need to complete 10 hours of mentoring. Required: Complete an application with the PUEENTE counselor prior to registration. This class is part of a Learning Community. Students must also enroll in GUID 1, CRN 10819. Students must attend a mandatory Puente Welcome on Wednesday, August 26, from 8:30 am - 1 pm in SS206. See ad on page 91.							
10159	Lec	PH102	Sandler S	3.2	3.0	TR	1120-1240
	Lab	LI120	Sandler S	1.0		R	1255-0145
Students enrolled in this class will participate in the PUEENTE program and will need to complete 10 hours of mentoring. Required: Complete an application with the PUEENTE counselor prior to registration. This class is part of a learning community. Students must also enroll in GUID 1, CRN 10819. Students must attend a mandatory Puente Welcome on Wednesday, August 26, from 8:30 am - 1 pm in SS206. See ad on page 91.							

Get College Credit for Working or Volunteering!

**Cooperative Work Experience**

is available to day, evening, full-time and part-time students.

If your job or volunteer work is directly related to your education or occupational goals sign up for:

CWE 190: Occupation Work Experience Education

If your job or volunteer work is not directly related to your educational goals sign up for:

CWE 192: General Work Experience Education

Call 408-848-4813 or email ssweeney@gavilan.edu for more information.

CRN Type Room Instructor Hrs. Units Days Begin-End**ENGL 260 Preparation for College Reading**

Transferable: No; GAV-GE:A3

This is a course presenting strategies in the technique and practice of college level critical reading and thinking skills. PREREQUISITE: Completion of English 420 or ESL 562 with a grade of 'C' or better or Assessment recommendation.

10187	Lec	HU103	Collins J	3.2	3.0	TR	0810-0930
10196	Lec	HOL2	Hull K	3.3	3.0	F	0900-1205
Above class meets at the Hollister Briggs site.							
10184	Lec	SS111	Hull K	3.2	3.0	MW	0945-1105
10195	Lec	HU102	Tracey I	3.3	3.0	F	1010-0115
10186	Lec	SS203	Hull K	3.2	3.0	MW	1120-1240
10188	Lec	MHG12	Hooper J	3.2	3.0	TR	0530-0650
Above class meets at Morgan Hill Community site.							
10961	Lec	HU103	Arora S	3.2	3.0	MW	0530-0650

1 Your ENGL 260 class has a theme.
2
3 See list on page 91.

FIRST YEAR EXPERIENCE ENGL 260 CLASSES:

10190	Lec	HU102	Smith K	3.2	3.0	TR	1120-1240
This class is part of a First Year Experience learning community. If you enroll you must also enroll in ENGL 250 CRN# 10182.							
10922	Lec	HU102	Smith K	3.2	3.0	TR	1120-1240
This class is part of a First Year Experience learning community. If you enroll in you must also enroll in ENGL 250 CRN #10183. Above class meets at the Hollister Briggs site.							
10189	Lec	HU102	Hooper J	3.2	3.0	MW	1250-0210
This class is part of a First Year Experience learning community. If you enroll you must also enroll in ENGL 250 CRN # 10179.							
10921	Lec	HU102	Hooper J	3.2	3.0	MW	1250-0210
This class is part of a First Year Experience learning community. If you enroll you must also enroll in ENGL 250 CRN# 10180.							

CRN Type Room Instructor Hrs. Units Days Begin-End

ENGL 420 Reading Improvement

Transferable: No

This is a practical, "how to" course teaching various methods of learning and reading college material. Using group and individual instruction in vocabulary, comprehension, and study skills, the students will increase their ability to survive academically, to profit, grow and succeed in all college courses, and to enjoy reading and learning. Units earned in this course do not count toward the associate degree and/or certain certificate requirements. PREREQUISITE: Satisfactory score on the English placement examination.

10198	Lec	SS203	Tracey I	3.2	3.0	MW	0810-0930
	Lab	SS110	Tracey I	1.0		F	0810-0900
10199	Lec	SS203	Tracey I	3.2	3.0	MW	0810-0930
	Lab	SS110	Tracey I	1.0		F	0910-1000
10207	Lec	SS111	Hirasuna S	3.2	3.0	TR	0945-1105
	Lab	LI120	Hirasuna S	1.0		T	1120-1210
10208	Lec	SS111	Hirasuna S	3.2	3.0	TR	0945-1105
	Lab	LI120	Hirasuna S	1.0		R	1120-1210
10209	L/L	HOL5	Parker V	4.6	3.0	TR	0530-0735

Above class meets at the Hollister Briggs site.

FIRST YEAR EXPERIENCE ENGL 420 CLASSES:

10202	Lec	HU103	Warren K	3.2	3.0	MW	0945-1105
	Lab	LI171	Warren K	1.0		T	1010-1100

This class is part of a First Year Experience Learning Community. If you enroll in this class you must also enroll in ENGL 440, # 10213.

10203	Lec	HU103	Warren K	3.2	3.0	MW	0945-1105
	Lab	SS216	Warren K	1.0		M	0100-0150

This class is part of a First Year Experience Learning Community. If you enroll in this class you must also enroll in ENGL 440, #10211.

③ 10200 Lec SS203 Roscher J 3.2 3.0 TR 1120-1240

Lab SS216 Roscher J 1.0 T 1010-1100

This class is part of a First Year Experience learning community. If you enroll you must also enroll in ENGL 440 CRN # 10219.

③ 10201 Lec SS203 Roscher J 3.2 3.0 TR 1120-1240

Lab SS216 Roscher J 1.0 R 1010-1100

This class is part of a First Year Experience learning community. If you enroll you must also enroll in ENGL 440 CRN # 10218.

ENGL 439 Basic Grammar and Reading

Transferable: No

This is a remediation course introducing basic reading and writing strategies, as well as study skills. Group and individual instruction will be used to build vocabulary, increase reading comprehension, develop study skills, and apply basic grammar to writing. Units earned in this course do not count toward the associate degree and/or certain certificate requirements. This is a pass/no pass course. ADVISORY: Assessment recommendation.

10210	Lec	PB4A	White S	3.2	4.0	MW	0945-1105
	Lab	SS111	White S	3.3		F	0900-1205

ENGL 749

WRITER'S WORKSHOP

Instructor: Kimberly Smith

Wednesday, 1:30 - 4:30 pm
480 Eighth Street, Gilroy in the Family Academy Room.

See listing in the Noncredit section beginning on page 127

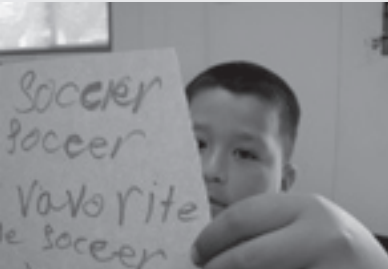

We help learners of all ages!

- Free tutoring for kids, teens and parents.
- Fun writing games and prompts.
- A relaxed and friendly atmosphere.

1st Year Experience

is a program in place in many schools across the country. These programs are in response to much research supporting smaller schools, interdisciplinary studies, and community building. So what is FYE? At Gavilan, this program links fundamental courses together. By studying and working together with your classmates and instructors, you will develop a stronger network of support. Students who enroll in FYE often report higher GPA, increased involvement in school, more friends, greater ability to meet goals, and stronger critical thinking, reading, and writing abilities.

Mark your calendars! This semester we are also offering two Friday First Year Seminars from 1-3:30 on Friday, September 25 and Friday, October 23.

The following classes are part of a First Year Experience learning community. You must enroll in both courses.

ENGL 250 Practical Writing

10179	Lec	HU102	Hooper J	3.2	3.0	MW	1120-1240
	Lab	LI120	Hooper J	1.0		M	1010-1100

and

ENGL 260 Preparation for College Reading

10189	Lec	HU102	Hooper J	3.2	3.0	MW	1250-0210
-------	-----	-------	----------	-----	-----	----	-----------

or

ENGL 250 Practical Writing

10180	Lec	HU102	Hooper J	3.2	3.0	MW	1120-1240
	Lab	LI120	Hooper J	1.0		W	0230-0320

and

ENGL 260 Preparation for College Reading

10921	Lec	HU102	Hooper J	3.2	3.0	MW	1250-0210
-------	-----	-------	----------	-----	-----	----	-----------

or

ENGL 250 Practical Writing

10182	Lec	HU102	Smith K	3.2	3.0	TR	1250-0210
	Lab	LI120	Smith K	1.0		T	1010-1100

and

ENGL 260 Preparation for College Reading

10190	Lec	HU102	Smith K	3.2	3.0	TR	1120-1240
-------	-----	-------	---------	-----	-----	----	-----------

or

ENGL 250 Practical Writing

10183	Lec	HU102	Smith K	3.2	3.0	TR	1250-0210
	Lab	LI120	Smith K	1.0		R	1010-1100

and

ENGL 260 Preparation for College Reading

10922	Lec	HU102	Smith K	3.2	3.0	TR	1120-1240
-------	-----	-------	---------	-----	-----	----	-----------

Don't forget

A counselor's signature is required if you take over 17.99 units (spring/fall) or over 5.99 units (summer).

You do not need a counselor's signature to register for a class with a prerequisite that was successfully completed at Gavilan.

Classroom Locations: Refer to "How to Use This Schedule" on page 5.

FIRST YEAR EXPERIENCE cont.

Is this your first year at Gavilan? Looking for a community of people like you? Then this learning community program is specially designed for you. The first year of college can be challenging for many students. By studying and working together with your classmates and instructors, in this program you'll develop a strong network of support to help you succeed. You'll improve your reading and writing skills and also explore options for majors, transferring, and careers. Building a strong foundation in your first year will put you on the road to success throughout your college experience.



The Program: Students will take reading and writing together because these skills are needed to succeed in college classes.

The following classes are part of a First Year Experience learning community. You must enroll in both courses.

ENGL 420 Reading Improvement

10203	Lec	HU103	Warren K	3.2	3.0	MW	0945-1105
	Lab	SS216	Warren K	1.0		M	0100-0150

and

ENGL 440 Basic Writing

10211	Lec	HU103	Warren K	3.2	3.0	MW	1120-1240
	Lab	LI120	Warren K	1.0		W	0100-0150

_____ or _____

ENGL 420 Reading Improvement

10202	Lec	HU103	Warren K	3.2	3.0	MW	0945-1105
	Lab	LI171	Warren K	1.0		T	1010-1100

and

ENGL 440 Basic Writing

10213	Lec	HU103	Warren K	3.2	3.0	MW	1120-1240
	Lab	LI171	Warren K	1.0		R	1010-1100

_____ or _____

ENGL 420 Reading Improvement

10201	Lec	SS203	Roscher J	3.2	3.0	TR	1120-1240
	Lab	SS216	Roscher J	1.0		R	1010-1100

and

ENGL 440 Basic Writing

10218	Lec	SS203	Roscher J	3.2	3.0	TR	1250-0210
	Lab	LI120	Roscher J	1.0		T	0230-0320

_____ or _____

ENGL 420 Reading Improvement

10200	Lec	SS203	Roscher J	3.2	3.0	TR	1120-1240
	Lab	SS216	Roscher J	1.0		T	1010-1100

and

ENGL 440 Basic Writing

10219	Lec	SS203	Roscher J	3.2	3.0	TR	1250-0210
	Lab	LI120	Roscher J	1.0		R	0230-0320

ENGL 440 Basic Writing

Transferable: No

This is an intensive study and application of basic grammar, sentence, and essay writing skills within the context of composing short essays. Units earned in this course do not count toward the associate degree and/or certain certificate requirements. PREREQUISITE: Satisfactory score on the English placement examination.

10220	Lec	SS111	Bragger M	3.2	3.0	TR	0810-0930
	Lab	LI120	Bragger M	1.0		F	0810-0900
10221	Lec	SS111	Bragger M	3.2	3.0	TR	0810-0930
	Lab	LI120	Bragger M	1.0		F	0910-1000
10214	Lec	SS203	Crook E	3.2	3.0	MW	0945-1105
	Lab	LI120	Crook E	1.0		M	1120-1210
10215	Lec	SS203	Crook E	3.2	3.0	MW	0945-1105
	Lab	LI120	Crook E	1.0		W	1120-1210
10216	Lec	HU103	Crook E	3.2	3.0	TR	1120-1240
	Lab	LI171	Crook E	1.0		R	1250-0140
10217	Lec	HU103	Crook E	3.2	3.0	TR	1120-1240
	Lab	LI171	Crook E	1.0		T	1250-0140

10225	Lec	SS111	Diehl K	3.2	3.0	MW	0530-0650
	Lab	LI120	Diehl K	1.0		M	0700-0750

10226	Lec	SS111	Diehl K	3.2	3.0	MW	0530-0650
	Lab	LI120	Diehl K	1.0		W	0700-0750

10222	Lec	HOL5	Parker V	3.2	3.0	TR	0745-0905
	Lab	HOL5	Parker V	1.0		T	0910-1000

Above class meets at the Hollister Briggs site.

10223	Lec	HOL5	Parker V	3.2	3.0	TR	0745-0905
	Lab	HOL5	Parker V	1.0		R	0910-1000

Above class meets at the Hollister Briggs site.

FIRST YEAR EXPERIENCE ENGL 440 CLASSES:

10211	Lec	HU103	Warren K	3.2	3.0	MW	1120-1240
	Lab	LI120	Warren K	1.0		W	0100-0150

This class is part of a First Year Experience Learning Community. If you enroll you must also enroll in ENGL 420, # 10203.

10213	Lec	HU103	Warren K	3.2	3.0	MW	1120-1240
	Lab	LI171	Warren K	1.0		R	1010-1100

This class is part of a First Year Experience Learning Community. If you enroll you must also enroll in ENGL 420, # 10202.

10218	Lec	SS203	Roscher J	3.2	3.0	TR	1250-0210
	Lab	LI120	Roscher J	1.0		T	0230-0320

This class is part of a First Year Experience learning community. If you enroll you must also enroll in ENGL 420 CRN # 10201.

10219	Lec	SS203	Roscher J	3.2	3.0	TR	1250-0210
	Lab	LI120	Roscher J	1.0		R	0230-0320

This class is part of a First Year Experience learning community. If you enroll you must also enroll in ENGL 420 CRN # 10200.

ENGLISH AS A SECOND LANGUAGE

All new ESL students must go through the ESL assessment process. See page 134.

Todos los nuevos estudiantes de ESL deben tomar el examen de nivelación de ESL. Consulte la página 134.

ESL 501 Survival ESL I

Transferable: No

This is a course in survival English for students with little or no oral or written English competency. It will give students basic vocabulary and familiarity in life skill areas such as the family, food, health, and occupations. The course integrates listening, speaking, reading, and writing. (ESL 501, 502, and 503 are sequential courses that may be taken in full form or in halves, preferably A before B.) This is a pass/no pass course. ADVISORY: ESL assessment recommendation

10063	L/L	HOL4	STAFF S	10.0	6.0	MTWRF	1115-0110
-------	-----	------	---------	------	-----	-------	-----------

Above class meets at the Hollister Briggs site.

CRN Type Room Instructor Hrs. Units Days Begin-End

ESL 503 Survival ESL III

Transferable: No

This is a third course in survival English for students with beginning oral or written English competency. It will reinforce basic skills learned and continue to develop vocabulary and ease of communication in life skill areas such as the family, the larger community, health, employment, and leisure activities. The course integrates listening, speaking, reading, and writing. (ESL 501, 502, and 503 are sequential courses that may be taken in full form or in halves, preferably A before B.) This is a pass/no pass course. ADVISORY: ESL 502 or ESL 502A and ESL 502B or ESL assessment recommendation.

10064 L/L HOL4 Howel J 10.0 6.0 MTWRF 0910-1105
Above class meets at the Hollister Briggs site.

ESL 510A Basic ESL I

Transferable: No

This is an intensive, integrated-skill course for students with little English. Through listening, speaking, reading and writing activities, students learn to use the structures of English with increasing accuracy, while gaining basic life skills. ADVISORY: ESL Assessment Recommendation.

10065 L/L CJ500 Cisneros N 9.0 9.0 MTWRF 0950-1120
ARR TBA 2.0
10066 L/L CJ500 Polizzotto J 9.0 9.0 MTWRF 0810-0940
ARR TBA 2.0

ESL 510B Basic ESL II

Transferable: No

This course is a continuation of ESL 510A. This is an intensive, integrated-skill program for students who function in a limited way in English. Through listening, speaking, reading and writing activities, students continue learning to use the structures of English with increasing accuracy, while gaining further basic life skills. ADVISORY: ESL 510A or ESL assessment recommendation.

10067 L/L CJ500 Baameur K 9.0 9.0 MTWRF 1130-0100
ARR TBA 2.0

ESL 521 Beginning ESL Listening/Speaking

Transferable: No

This course develops basic listening and speaking skills, moving from a functional survival context to academic readiness. Activities are directed at providing practice through listening exercises, role-play, pair work, small and large group discussion, interviews, and oral presentations. ADVISORY: ESL 510B or ESL Assessment Test Recommendation. Recommended concurrent enrollment in ESL 522 and 523.

10068 L/L LI100 Lawn B 4.2 4.0 MWF 1100-1210
ARR TBA 1.0

ESL 522 Beginning ESL Reading/Vocabulary

Transferable: No

This course begins the development of reading skills and vocabulary through the application of different reading strategies to a variety of selections on topics of interest to academically-bound students. ADVISORY: ESL 510B or 510C or Assessment recommendation. Recommended concurrent enrollment in ESL 521 and 523.

10242 Lec HU101 Guzman D 3.2 3.0 TR 0945-1105

ESL 523 Beginning ESL Grammar/Writing

Transferable: No

This is a beginning grammar/writing course for students with very basic grammar. The focus is on basic grammatical structures, punctuation and sentence skills. ADVISORY: ESL 510B or ESL Assessment Test recommendation. Recommended concurrent enrollment in ESL 521 and ESL 522.

10069 L/L HU104 Wexler L 5.2 5.0 MTWR 0810-0915
ARR TBA 1.0

CRN Type Room Instructor Hrs. Units Days Begin-End

ESL 527 Integrated Reading-Writing I

Transferable: No

This is the first course in a series of integrated skills courses designed to develop the reading, writing and grammar skills of ESL students. This beginning course focuses on vocabulary development, basic reading strategies and comprehension, basic grammar and beginning writing skills (sentence level and basic paragraphs.) The aim of this course is to assist beginning level students in becoming more literate while participating in holistic reading and writing activities based on engaging multicultural topics. PREREQUISITE: ESL 510B or ESL 503, or ESL assessment recommendation.

10094 Lec HU104 Shelley A 6.0 6.0 TR 0630-0930

10095 Lec HOL6 Staff 5.7 6.0 MWF 0630-0805
Above class meets at the Hollister Briggs site.

ESL 531 Intermediate ESL Listening/Speaking I

Transferable: No

In this course, listening and speaking skills are developed through extended listening exercises, open-ended dialogues, pair and group discussions, oral interviews, and oral reports. PREREQUISITE: ESL 521 with a grade of 'C' or better or ESL Assessment Recommendation. Recommended concurrent enrollment in ESL 532 and 533.

10251 Lec HU101 Sanidad M 4.2 4.0 MWF 0945-1055
ARR TBA 1.0

ESL 532 Intermediate ESL Reading/Vocabulary I

Transferable: No

This course continues the development of reading skills and vocabulary through the application of different reading strategies to a variety of selections on topics of interest to academically-bound students. PREREQUISITE: ESL 522 with a grade of 'C' or better or ESL assessment recommendation. Recommended concurrent enrollment in ESL 531 and 533.

10078 Lec LI100 Wexler L 3.2 3.0 TR 1100-1220

ESL 533 Intermediate ESL Grammar/Writing I

Transferable: No

This course involves the practice and refinement of sentence and paragraph skills, structure and punctuation. Students will learn basic use of the computer as a writing tool. PREREQUISITE: ESL 523 with a grade of C or better or ESL Assessment Test recommendation. ADVISORY: Recommended concurrent enrollment in ESL 531 and ESL 532.

10084 L/L LI100 Lawn B 5.2 5.0 MTWR 1225-0130
ARR TBA 1.0

ESL 537 Integrated Reading/Writing II

Transferable: No

This is the second course in a series of integrated skills courses designed to continue the development of reading, writing and grammar skills of low-intermediate ESL students. The course focuses on vocabulary development through the application of different reading strategies to a variety of selections of topics of interest to academically-bound students. It also involves the practice and refinement of sentence and paragraph skills, structure and pronunciation. PREREQUISITE: ESL 523 and ESL 522, or ESL 527, or ESL Assessment Recommendation.

10862 Lec HU101 Guzman D 6.0 6.0 TR 0630-0930

ESL 541 Intermediate ESL Listening/Speaking II

Transferable: No

This course expands listening and speaking skills through extended listening exercises, open-ended dialogues, pair and group discussions, oral interviews, and oral reports. Students broaden vocabulary while listening to and speaking in both formal and informal, conversational and academic situations. PREREQUISITE: ESL 531 with a grade of 'C' or better or ESL assessment recommendation. Recommended concurrent enrollment in ESL 542 and 543.

10253 Lec HU104 Wexler L 4.2 4.0 MWF 1225-0135
ARR TBA 1.0

Please help protect Gavilan's park-like setting by properly disposing of litter and recycling.

CRN Type Room Instructor Hrs. Units Days Begin-End

ESL 542 Intermediate ESL Reading/Vocabulary II

Transferable: No

This course begins the expansion of reading skills and vocabulary development through the application of different reading strategies to a variety of selections on topics of interest to academically-bound students including selections from literature. PREREQUISITE: ESL 532 with a grade of 'C' or better or ESL Assessment Recommendation. Recommended concurrent enrollment in ESL 541 and 543.

10261 Lec HU101 Carillo L 3.2 3.0 TR 0810-0930

ESL 543 Intermediate ESL Grammar/Writing II

Transferable: No

This course involves the expansion of sentence and paragraph skills, structure, and punctuation. Students will learn basic use of the computer as a writing tool. PREREQUISITE: ESL 533 with a grade of C or better or ESL assessment recommendation. ADVISORY: Recommended concurrent enrollment in ESL 541 and ESL 542.

10085 L/L HU104 Campbell K 5.2 5.0 TWR 0945-1050
ARR TBA 1.0

ESL 546 Introduction to Computers for ESL Students

Transferable: No

Introduction to basic computer hardware functions and terminology; overview of Windows operating environment and word processing for ESL students. ADVISORY: CSIS 122. Eligible for Gavilan College ESL Program Intermediate.

10086 L/L PB14 Cisneros N 1.0 1.0 W 1130-1220

ESL 552 Advanced ESL Reading/Vocabulary I

Transferable: No

This course focuses on academic and critical thinking skills needed to increase reading comprehension and efficiency. Emphasis is on analyzing, making inferences, taking notes, supporting opinions, summarizing and expanding vocabulary. Readings are from academic texts and literature. PREREQUISITE: ESL 542 with a grade of 'C' or better or ESL assessment recommendation. Recommended concurrent enrollment in ESL 553 and 554.

10262 Lec PH102 Wexler L 4.2 4.0 MWF 0945-1055

ESL 553 Advanced ESL Composition I

Transferable: No

This course is a composition course for ESL students that develops college composition skills through a review of the parts and elements of the English paragraph and an introduction to the essay form. The course focuses on the development of a paragraph and expands to the writing of multiple paragraphs in an essay. Basic rhetorical patterns and methods of organization are covered using the multiple-draft approach to writing. PREREQUISITE: ESL 543 with a grade of C or better or ESL Assessment Test recommendation. ADVISORY: Recommended concurrent enrollment in ESL 552 and ESL 554.

10090 Lec LI100 Cisneros N 5.2 5.0 MTWR 0810-0915
ARR TBA 1.0

ESL 554 Advanced ESL Grammar I

Transferable: No

This course is designed to help students improve their grammar usage so that they will be able to expand their use of grammar structures in oral and written communication. Students begin the study of more sophisticated grammar structures such as past and future perfect, passive voice, and modal auxiliaries for past time, and they review perfect and modals for present and future time. Students will enhance their understanding of grammar by comparing and contrasting new and previously encountered structures and better appreciate the subtleties of English grammar. PREREQUISITE: ESL 543 with a grade of 'C' or better or ESL Assessment Test Recommendation. ADVISORY: Recommended concurrent enrollment in ESL 552 and ESL 553.

10091 L/L HU104 Campbell K 5.2 5.0 MTRF 1110-1215
ARR TBA 1.0

ESL 562 Advanced ESL Reading/Vocabulary II

Transferable: No

This course prepares ESL students for mainstream college classes by reviewing a variety of reading skills, strategies, and topics from different academic disciplines. Students expand their academic vocabulary and read short stories or a novel for literary appreciation. PREREQUISITE: ESL 552 with a grade of 'C' or better or ESL assessment recommendation. Recommended concurrent enrollment in ESL 561 and/or ESL 564 and ESL 563.

10263 Lec HU101 Campbell K 4.2 4.0 MWF 0810-0920

OVERVIEW of ESL COURSES

NON CREDIT

LIFE SKILLS

ESL 777	ESL 778
ESL 779	ESL 780
ESL 781	ESL 782

VOCATIONAL

VESL ESL 704A/B

To move from noncredit to credit ESL classes students must take an ESL assessment.

CREDIT

SURVIVAL TRACK

ACADEMIC TRACK

ESL 501	→	Basic	510A		
ESL 502	→		510B		
ESL 503	→	Beginning	521 L/S	522R	523GW
		Intermediate I	531 L/S	532R	533GW
		Intermediate II	541 L/S	542R	543GW
		Advanced I		552R	553W 554G
		Advanced II	561 L/S	562R	563W 564G

SUPPLEMENTARY ESL COURSES:

- ESL 546 Intro Computers/ESL
- ESL 556 Intro Competency/ESL
- ESL 581 Pronunciation I
- ESL 582 Pronunciation II
- ESL 584 Culture through Film
- ESL 585 Editing for ESL Writers

ENGL 260 ENGL 250

ACADEMIC PROGRAMS or VOCATIONAL PROGRAMS

GRADUATION INFORMATION



Call 408-848-4737 for details about the graduation process.

The deadline for filling out a petition for graduation for fall is Monday, October 12th.

Admissions & Records

CRN Type Room Instructor Hrs. Units Days Begin-End

ESL 563 Advanced ESL Composition II

Transferable: No

This course, which is designed for ESL students, refines and further expands college composition skills through the writing of essays using the multiple-draft approach to writing. The course focuses on the structuring and development of an essay with the use of personal examples. Students write in response to a variety of prompts using different rhetorical patterns such as classification, cause/effect, and comparison/contrast. PREREQUISITE: ESL 553 with a grade of "C" or better or ESL Assessment Test recommendation. ADVISORY: Recommended concurrent enrollment in ESL 562 and ESL 564.

10092	Lec ARR	LI100	Lawn B TBA	5.2 1.0	5.0	TWRF	0945-1050
-------	------------	-------	---------------	------------	-----	------	-----------

ESL 564 Advanced ESL Grammar II

Transferable: No

This course is designed to expand grammar usage to include adjective, noun, and adverb clauses in oral and written communication. Students learn the meaning and use of clause connectors and are introduced to conditionals, both real and unreal. These grammar structures constitute some of the most complex structures in English and expose students to a rich variety of structures that can effectively enhance their oral and written expression. PREREQUISITE: ESL 554 with a grade of 'C' or better or ESL Assessment Recommendation. ADVISORY: Recommended concurrent enrollment in ESL 562 and ESL 563.

10093	L/L ARR	HU101	Sanidad M TBA	5.2 1.0	5.0	MTWR	1110-1215
-------	------------	-------	------------------	------------	-----	------	-----------

Film: see ENGL 2C, HUM 3, 4

Foreign Languages: See Chinese (CHN), French (FRNH), Japanese (JPN) and Spanish (SPAN)

FRENCH

FRNH 1A Elementary French

Transferable: CSU, UC; CSU-GE:C2, IGETC:6A; GAV-GE:C2

French 1A is a multi-skilled beginning level class with emphasis on understanding and speaking French. Students are introduced to the cultures and customs of various French-speaking countries.

10588	Lec	SS110	Sanidad M	5.2	5.0	MTWR	0810-0915
-------	-----	-------	-----------	-----	-----	------	-----------

 **FRNH 2A Intermediate French**

Transferable: CSU

In French 2A, students further develop skills acquired in first year French: they review grammatical structures and expand their vocabulary; they increase their communicative ability through the reading and discussion of excerpts of French literature and cultural texts of various francophone countries and written composition. PREREQUISITE: French 1B or equivalent.

10591	L/L	LI100	Maxwell K	6.4	5.0	MTWR	0230-0350
-------	-----	-------	-----------	-----	-----	------	-----------

 **FRNH 8A Conversational French**

Transferable: CSU

This beginning course emphasizes the sound system, pronunciation, and conversational skills used in everyday French but also covers vocabulary building and grammar as well. Students are introduced to the culture of a letter grade or pass/no pass.

10598	Lec	LI100	Maxwell K	3.3	3.0	T	0600-0905
-------	-----	-------	-----------	-----	-----	---	-----------

FRNH 23 Independent Study

Transferable: CSU

Designed to afford selected students specialized opportunities for exploring areas at the independent study level. The courses may involve extensive library work, research in the community, or special projects. May be repeated until six units of credit are accrued. This course has the option of a letter grade or pass/no pass. REQUIRED: The study outline prepared by the student and the instructor must be filed with the department and the dean.

10595	Ind	SS104	Sanidad M	2.0			
-------	-----	-------	-----------	-----	--	--	--

CRN Type Room Instructor Hrs. Units Days Begin-End

GEOGRAPHY

Geography: see also CSIS 61 (Geographic Info. Systems)

GEOG 1 Physical Geography

Transferable: CSU, UC; CSU-GE:B1, B3, IGETC:5A; GAV-GE:B1, B3; CAN:GEOG2

An introductory study of the basic physical elements of geography including climate, land forms, soils, water, and natural vegetation. The laboratory will include the tools and methods of geographers. ADVISORY: Eligible for English 250 and English 260.

10010	L/L	MHG12	Willahan D	5.4	3.0	TR	0945-1210
-------	-----	-------	------------	-----	-----	----	-----------

Above class meets at Morgan Hill Community site.

GEOLOGY

GEOG 1 Introduction to Geology

Transferable: CSU, UC; CSU-GE:B1, B3, IGETC:5A; GAV-GE:B1, B3; CAN:GEOG2

A study of the earth and the physical properties which modify the earth; minerals, rocks, geologic structures and processes. ADVISORY: Eligible for English 250 and English 260.

10362	L/L	SS206	Willahan D	6.6	4.0	TR	1250-0355
-------	-----	-------	------------	-----	-----	----	-----------

Government: see Political Science
Graphic Arts: see Art, CSIS, Digital Media

GUIDANCE

GUID 1 Self-Assessment and Career Development

Transferable: CSU; CSU-GE:E2; GAV-GE:E2

This course is designed to assist the student in learning more about personal values, personality, interests, exploration of career choice, and occupational opportunities through the use of various personal assessment instruments. The delivery options for this course also include online and self-paced formats. This course is also listed as PSYC 5. ADVISORY: Eligible for English 250 and English 260. \$12 fee will be charged for career assessment materials.

10833	Lec	CH105	Artega B	13.6	3.0	MTWR	0830-1140
-------	-----	-------	----------	------	-----	------	-----------

07/27/09 - 08/20/09

10810	Lec	CJ500	Godley J	3.2	3.0	TR	0105-0225
-------	-----	-------	----------	-----	-----	----	-----------

10812	Lec	HOL2	Lopez A	3.2	3.0	MW	0230-0350
-------	-----	------	---------	-----	-----	----	-----------

Above class meets at the Hollister Briggs site.

10813	Lec	SBHS-194	Caffiero J	3.2	3.0	MW	0400-0520
-------	-----	----------	------------	-----	-----	----	-----------

This class is part of the High Step Program. It will be offered at San Benito High School, room 194. This class is open to all students. For more information, see a Gavilan counselor.

10814	ONLINE	Sharboneau R		3.0			
-------	--------	--------------	--	-----	--	--	--

 You must have an email account to take this course. Start your course by going to www.gavilan.edu/disted. Unless you have made prior arrangements with the instructor, you MUST log on by 11:59 pm on the first day of the semester. Late adds must login within 24 hours of adding this course. If you miss the deadline you may be dropped. For help, contact your instructor or email disted@gavilan.edu.

10458	ONLINE	Tenney L		3.0			
-------	--------	----------	--	-----	--	--	--

 You must have an email account to take this course. Start your course by going to www.gavilan.edu/disted. Unless you have made prior arrangements with the instructor, you MUST log on by 11:59 pm on the first day of the semester. Late adds must login within 24 hours of adding this course. If you miss the deadline you may be dropped. For help, contact your instructor or email disted@gavilan.edu.

PUENTE LEARNING COMMUNITY GUID 1 CLASSES:

10819	Lec	LS106	Marquez C	3.2	3.0	MW	1120-1240
-------	-----	-------	-----------	-----	-----	----	-----------

Students enrolled in this class will participate in the PUENTE program and will need to complete 10 hours of mentoring. Required: Complete an application with the PUENTE counselor prior to registration. This class is part of a learning community. Students must also enroll in ENGL 250, CRN 10158 or 10159. Students must attend a mandatory Puente Welcome on Wednesday, August 26, from 8:30 am - 1 pm in SS206. See ad on page 91.

CRN Type Room Instructor Hrs. Units Days Begin-End

GUID 6 Life Skills for Higher Education

Transferable: CSU, UC; CSU-GE:E2; GAV-GE:E2

Evaluation and application of academic study methods to achieve subject matter mastery. Development of critical thinking skills, and application of reading, writing, note taking and test taking methods to improve personal strategies. Exploration of personal lifestyle and health factors, including the causes and management of stress, as it relates to academic success. Assessment of academic and career goals, selection of majors, and development of education plans. Topics covered include creative and realistic goal setting, academic and life management, college and community resources, library and Internet use, time management, and techniques to reduce math and science anxiety. This class will address a multitude of cultural learning styles, with emphasis on attaining professional, personal and academic goals in a diverse society. Topics from developmental psychology, learning theory and personality theory. ADVISORY: Eligible for English 250 and English 260.

10818 Lec PB3 TBA 2.3 2.0 M 0810-1015

GUID 22 Field Work and Service

Transferable: CSU

Supervised field work within the college and with local agencies. Students serve in useful group activities in leadership roles prescribed for them by faculty or community agencies. A maximum of six units may be completed. This is a pass/no pass course. REQUIRED: Learning contracts must be filled out and signed by the student and the supervising instructor.

10537 Fld Ex LI117 STAFF S 1.0 day/time - see instructor
Contact the Disability Resource Center (DRC) office.

GUID 28 Tutoring Techniques

Transferable: CSU

This course is designed to train students in effective tutoring skills, introduction to how people learn, teaching to modalities, and techniques of working with student anxiety. This course has the option of a letter grade or pass/no pass. ADVISORY: English 250.

10815 Lec PB4A Cribb G 3.0 1.0 TR 0815-0930
09/01/09 - 10/08/09

GUID 29 Tutoring Lab

Transferable: CSU

This course will allow students to gain valuable experience in the field of teaching. Students will practice the skills they have learned in Guidance 28. Guidance 29 may be repeated for a maximum of 2.0 units per semester and a maximum course total of 8.0 units. This is a pass/no pass course. ADVISORY: Completion of, or concurrent enrollment in Guidance 28.

10816 Lab LI116 King D 1.0
Open-entry, open-exit class.
10817 Lab LI116 King D 2.0
Open-entry, open-exit class.

GUID 530 Job Readiness

Transferable: No

This course is designed to provide a comprehensive, well-organized approach to assist individuals with the identification of occupational choices and the development of job readiness skills necessary to obtain and maintain employment in a competitive or supported work setting. May be repeated twice for credit. This course has the option of a letter grade or pass/no pass.

10538 Lec APE120/121 Franklin L 3.2 3.0 MW 0945-1105

GUID 550 Supervised Tutoring

Transferable: No

Laboratory class emphasizing college learning skills, appropriate study techniques, and learning assistance utilizing one-one-one or small group tutorial.

10914 Lab Computer Place
10915 Lab Digital Media Lab
10916 Lab Health Occupations Lab
10917 Lab Math Lab
10918 Lab Tutoring Center
10919 Lab Tutoring Center
10920 Lab Writing Center



**C'est Chic!
Learn French!**

Two new 3 unit classes!

FRNH 2A Elementary French

CRN 10591
Monday-Thursday
2:30-3:50 pm
Instructor: Kitty Maxwell

Prerequisite: French 1B or equivalent
You are eligible if you have successfully completed two years of high school French.
This course satisfies the general education Humanities (Area C-2) requirement under the AA/AS Degree and transfers to CSU as an elective.

FRNH 8A Conversational French

CRN 10598
Tuesday
6:00-9:05 pm
Instructor: Kitty Maxwell

No Prerequisites!
This course satisfies the general education Humanities (Area C-2) requirement under the AA/AS Degree and transfers to CSU as an elective.



The Puente Project is a two-semester program that combines three components: writing, counseling and mentoring to support students to transfer to four-year universities and colleges. The Guidance 1 course focuses on self assessment and career development. The English 250 course focuses on Mexican American/Latino literature. The program also includes a student leadership conference, university visits and mentor/student socials. The program is open to all eligible students. For more information, call Celia Marquez, Puente Co-Coordinator at 408-848-4807.

Required: Complete a program application with the Puente Counselor prior to registration. Students must attend a mandatory Puente Welcome on Wednesday, August 26, from 8:30 am - 1 pm in SS206.

GUID 1 CRN 10819 LS106 Marquez C MW 1120A-1240P
Students will need to complete 10 hours of mentoring.

Choose one of the ENGL 250 courses listed below:

ENGL 250 CRN 10158 PH102 Sandler S TuTh 1120A -1240P
LI120 Sandler S T 1255P - 0145P
ENGL 250 CRN 10159 PH102 Sandler S TR 1120A - 1240P
LI120 Sandler S R 1255P - 0145P

Your educational plan:

You are expected to take the responsibility for scheduling an appointment with a counselor, preferably at least once a semester. The purpose of this appointment is to develop, review and update your educational plan to ensure that you are taking the appropriate courses to meet your educational goal.

CRN Type Room Instructor Hrs. Units Days Begin-End

GUID 557 Learning Skills Assessment

Transferable: No

This course provides an assessment of the students' cognitive/perceptual abilities and basic skills academic achievement. The assessment results are used to determine the students' eligibility for Learning Disabilities Services, to develop individual educational plans, and/or to improve the students' understanding of their own learning strengths and weaknesses. The assessment is conducted on a one-to-one basis by appointment. Units earned in this course do not count toward the associate degree and/or certificate requirements. This is a pass/no pass course.

10539 Lab LI117 Burgman L .5 day/time - see instructor
Overson R

Open Entry-Open Exit. Make an appointment with the Disability Resource Center (DRC) office.

GUID 558 Learning Skills Laboratory

Transferable: No

The Learning Skills Laboratory is designed to assist students who are eligible to receive Learning Disabilities Services and/or have demonstrated academic deficits. The course content is individualized and based on Student Educational Contracts which are developed for each student. Students receive supplemental instruction, academic support, and learning strategy suggestions appropriate for their individual cognitive, perceptual, and academic strengths and weaknesses. Units earned do not count towards the associate degree and/or certificate requirements. This is a pass/no pass course. ADVISORY: Completion of Guidance 557 or demonstrated academic deficit.

Mandatory course orientation for the following classes will be conducted Tuesday, September 8 from 8:30-9:30 AM in the DRC Learning Skills Lab LI 117, Wednesday, September 9 from 12:30-1:30 PM in the DRC Learning Skills Lab LI 117, and Thursday, September 10 from 5:30-6:30 PM in the DRC Learning Skills Lab LI 117. Students need to attend one of the three meetings. Please contact Robert Overson at: roverson@gavilan.edu or (408) 846-4924.

10541 Lab LI116 Overson R .5 day/time - see instructor
Burgman L

Open Entry-Open Exit

10543 Lab LI116 Overson R 1.0 day/time - see instructor
Burgman L

Open Entry - OpenExit

10545 Lab LI116 Overson R 2.0 day/time - see instructor
Burgman L

Open Entry - Open Exit

GUID 561 Writing Skills

Transferable: No

This course is designed to teach basic writing skills to students who have demonstrated difficulty mastering written language and who are eligible to receive Learning Disability Services. Material is presented in a concrete, multi-sensory manner, and the class includes opportunity for immediate practice, repetition, and review. The course content includes grammar, sentence structure, and punctuation. Units earned do not count toward the associate degree and/or certificate requirements. This course has the option of a letter grade or pass/no pass. ADVISORY: Completion of Guidance 557 or demonstrated deficit in written language achievement. Recommended for students with verified learning disability.

10547 L/L PB4A Maringer J 2.0 1.0 TR 1250-0150

GUID 562 Directed Study Lab in Arithmetic

Transferable: No

This course is designed for students who have demonstrated difficulty in mastering arithmetic and who are eligible to receive Learning Disability Services. Course content parallels Mathematics 400. Material is presented in a concrete, multi-sensory manner, and the lab allows opportunity for immediate practice, questions, repetition, and review. Units earned do not count toward the associate degree and/or certificate requirements. This is a pass/no pass course. COREQUISITE: Concurrent enrollment in MATH 400. ADVISORY: Completion of GUID 557 and/or a demonstrated deficit in arithmetic. Recommended for students with verified learning disability.

10548 Lab PB4A Burgman L 3.2 1.0 TR 1120-1240

CRN Type Room Instructor Hrs. Units Days Begin-End

GUID 563A Directed Study Lab in Algebra

Transferable: No

This course is designed for students who have demonstrated difficulty mastering elementary algebra and who are eligible to receive Learning Disability Services. Course content parallels Mathematics 205A. Material is presented in a concrete, multi-sensory manner, and the lab allows opportunity for immediate practice, questions, repetition, and review. This is a pass/no pass course. COREQUISITE: Concurrent enrollment in MATH 205A is required. ADVISORY: Completion of GUID 557 or demonstrated deficit in mathematics. Recommended for students with verified learning disability.

10549 Lab APE120/121 Overson R 3.2 1.0 MW 1120-1240
ARR TBA 1.0

GUID 563B Directed Study Lab in Algebra

Transferable: No

This course is designed for students who have demonstrated difficulty mastering elementary algebra and who are eligible to receive Learning Disability Services. Course content parallels Mathematics 205B. Material is presented in a concrete, multi-sensory manner, and the lab allows opportunity for immediate practice, questions, repetition, and review. This is a pass/no pass course. COREQUISITE: Concurrent enrollment in MATH 205B is required. ADVISORY: Completion of GUID 557 or demonstrated deficit in mathematics. Recommended for students with verified learning disability.

10607 Lab APE120/121 Overson R 3.2 1.0 TR 0945-1105
ARR TBA 1.0

GUID 564 Directed Study Lab in Pre-Algebra

Transferable: No

This course is designed for students who are eligible to receive Learning Disability Services and/or who have demonstrated difficulty in mastering pre-algebra. The course content parallels Mathematics 402. The material is presented in a concrete, multi-sensory manner, and the lab environment allows opportunity for immediate practice questions, repetition and review. Units earned do not count towards the associate degree and/or certificate requirements. This is a pass/no pass course. COREQUISITE: Concurrent enrollment in MATH 402. ADVISORY: Completion of Guidance 557 and/or a demonstrated deficit in Mathematics. Recommended for students with verified learning disability.

10620 Lab PB4A Burgman L 3.2 1.0 MW 1120-1240

HEALTH EDUCATION

HE 1 Health Education

Transferable: CSU, UC; CSU-GE:E2; GAV-GE:E2

This course focuses on attaining individual awareness, critical-thinking skills and self-responsibility relating to personal health. The interaction of individual physical, psychological, social, emotional, spiritual and environmental factors in determining health status is developed through integration of major concepts. This course has the option of a letter grade or pass/no pass. ADVISORY: Eligible for English 250 and English 260.

10404 Lec LS106 Dodd S 3.2 3.0 TR 0945-1105

10406 Lec MHG12 Dodd S 3.3 3.0 W 0600-0905
Above class meets at Morgan Hill Community site.

10405 ONLINE Quatre S 3.0

You must have an email account to take this course. Start your course by going to www.gavilan.edu/disted. Unless you have made prior arrangements with the instructor, you MUST log on by 11:59 pm on the first day of the semester. Late adds must login within 24 hours of adding this course. If you miss the deadline you may be dropped. For help, contact your instructor or email disted@gavilan.edu.

Don't forget

A counselor's signature is required if you take over 17.99 units (spring/fall) or over 5.99 units (summer).

You do not need a counselor's signature to register for a class with a prerequisite that was successfully completed at Gavilan.

Have you met the prerequisite?

It's required!

Classroom Locations: Refer to "How to Use This Schedule" on page 5.

Check out *Classes offered at the satellite sites...*
Hollister classes - page 60. Morgan Hill classes - page 62.

CRN Type Room Instructor Hrs. Units Days Begin-End

HE 2 Human Sexuality

Transferable: CSU, UC; CSU-GE:E2; GAV-GE:E2

Assists students in gaining increased knowledge, appreciation, and respect for their own sexuality, as well as others. Approved by the Board of Registered Nursing for 54 hours of continuing education credit (Provider #00892). ADVISORY: Eligible for English 250 and English 260

10383 Lec LS106 Logan C 3.2 3.0 MW 0945-1105

10376 ONLINE Quatre S 3.0

 You must have an email account to take this course. Start your course by going to www.gavilan.edu/disted. Unless you have made prior arrangements with the instructor, you MUST log on by 11:59 pm on the first day of the semester. Late adds must login within 24 hours of adding this course. If you miss the deadline you may be dropped. For help, contact your instructor or email disted@gavilan.edu.

10378 ONLINE Quatre S 3.0

 You must have an email account to take this course. Start your course by going to www.gavilan.edu/disted. Unless you have made prior arrangements with the instructor, you MUST log on by 11:59 pm on the first day of the semester. Late adds must login within 24 hours of adding this course. If you miss the deadline you may be dropped. For help, contact your instructor or email disted@gavilan.edu.

HISTORY

HIST 1 United States History through Reconstruction

Transferable: CSU, UC; CSU-GE:C2, D6, IGETC:3B, 4F, 7B; GAV-GE:C2, D2; CAN:HIST8, HIST SEQ B

History of the United States from the time before European contact with the Americas through Reconstruction. Emphasis will be placed on distinctive patterns of political, economic, social, intellectual, and geographic developments within their global context. At the conclusion of the course, the student should understand major themes in the history of the United States, and be able to explain various ways in which ideas about federal vs. state power, ethnicity, class, and gender divisions have influenced the nation's development. This course has the option of a letter grade or pass/no pass. ADVISORY: Eligible for English 250 and English 260.

10012 Lec SS214 Halper L 3.2 3.0 TR 0945-1105

10013 Lec MHG12 Mosher C 3.2 3.0 MW 0945-1105
Above class meets at Morgan Hill Community site.

10014 Lec HOL2 Luna E 3.2 3.0 TR 0945-1105
Above class meets at the Hollister Briggs site.

10011 Lec SS214 Halper L 3.2 3.0 MW 0230-0350

10015 Lec SS214 Halper L 3.3 3.0 R 0600-0905

HIST 2 United States History Reconstruction to the Present

Transferable: CSU, UC; CSU-GE:C2, D6, IGETC:3B, 4F, 7B; GAV-GE:C2, D2; CAN:HIST10, HIST SEQ B

History of the United States from Reconstruction to the present. Emphasis will be placed on distinctive patterns of political, economic, social, intellectual, and geographic developments within their global context. At the conclusion of the course, the student should understand major themes in the history of the United States, and be able to explain various ways in which ideas about federal vs. state power, ethnicity, class, and gender divisions have influenced the nation's development. This course has the option of a letter grade or pass/no pass. ADVISORY: Eligible for English 250 and English 260.

10019 Lec MHG12 Mosher C 3.2 3.0 MW 0810-0930
Above class meets at Morgan Hill Community site.

10023 Lec SS214 Luna E 3.2 3.0 MW 0945-1105

10020 Lec HOL2 Luna E 3.2 3.0 TR 1120-1240
Above class meets at the Hollister Briggs site.

10022 Lec SS214 Kier D 3.2 3.0 TR 1120-1240

10017 Lec HOL2 Luna E 3.3 3.0 T 0600-0905
Above class meets at the Hollister Briggs site.

10018 ONLINE Guardino L 3.0

 You must have an email account to take this course. Start your course by going to www.gavilan.edu/disted. Unless you have made prior arrangements with the instructor, you MUST log on by 11:59 pm on the first day of the semester. Late adds must login within 24 hours of adding this course. If you miss the deadline you may be dropped. For help, contact your instructor or email disted@gavilan.edu.

Day of Beauty

for Men & Women

Includes:

- ✓ Hair cut & style
- ✓ Deep conditioning
- ✓ Scalp treatment
- ✓ Manicure
- ✓ Facial
- ✓ Eyebrow arch
- ✓ Makeup

no substitutions

only **\$30**
w/o coupon - \$35



DISCOUNTS

Senior Citizens: 20% daily

Staff/Students: 10% daily

Discounts not applicable to DAILY SPECIALS, Special perms or any service under \$6.00

Spring/Fall hours

Wed.-Fri. 10:00 am - 2:30 pm

Summer hours

Tu.-Th. 10:30 am - 3:30 pm

DAILY SPECIALS

Wednesday:

Hair Cut ONLY - \$5.50

Hair Cut & Style - \$10

Thursday/Friday:

All Basic Perms - 20% off

Plain Manicure & Pedicure - \$11

Wednesday/Friday:

Hair Color - 20% off

All work performed by students supervised by instructors.

Discounts not applicable to daily specials, special color, special perms or any service under \$6. Not valid with any other discounts.

For appointments call 408-842-5055

CRN Type Room Instructor Hrs. Units Days Begin-End

HIST 3 History of California

Transferable: CSU, UC; CSU-GE:C2, D6, IGETC:3B, 4F; GAV-GE:C2, D2, F

A study of California's history from pre-contact with Europeans to the present day. Social, cultural, economic, political and environmental issues will be explored towards an understanding of California's history. ADVISORY: Eligible for English 1A and English 260.

10024 Lec SS110 Halper L 3.2 3.0 MW 1120-1240

This service learning section involves community work. See page 64 for details.

HIST 4B History of World Societies 1500 to Present

Transferable: CSU, UC; CSU-GE:C2, D6, IGETC:3B, 4F; GAV-GE:C2, D2

A study of major elements in the development of and interactions between world societies, from the dawn of the Renaissance to the modern day. Students will comparatively analyze the social, cultural, geographic, economic, demographic, technological, environmental, and political developments that moved humans from the Middle Ages to the modern era. This course has the option of a letter grade or pass/no pass. ADVISORY: English 250 and English 260.

10025 Lec SS205 Mosher C 3.3 3.0 W 0600-0905

HIST 5 Women's Lives in Early United States History

Transferable: CSU, UC; CSU-GE:C2, D4, D6, IGETC:3B, 4F; GAV-GE:C2, D1, D2, F

This survey course begins with pre-contact peoples and extends to the end of the nineteenth century. The class examines the construction of womanhood through United States history, and the effects of gender, ethnicity, class, and sexual orientation upon women's experiences. Students will study the contributions of various individual women and groups of women in creating the modern United States, and will analyze social, political, economic, and cultural forces affecting women to both join and resist movements for social change. Students will also learn to apply contemporary feminist theory to traditional historical approaches. This course has the option of a letter grade or pass/no pass. ADVISORY: Eligible for English 250 and English 260.

10021 Lec SS214 Guardino L 3.3 3.0 F 0810-1115

This service learning section involves community work. See page 64 for details.

CRN Type Room Instructor Hrs. Units Days Begin-End

HIST 7A History of Western Civilization

Transferable: CSU, UC; CSU-GE:C2, IGEC:3B; GAV-GE:C2; CAN:HIST2, HIST SEQ A

A study of major elements in Western heritage from the ancient world to the eighteenth century. Course will survey intellectual, political, social, economic and cultural development of the Western World. ADVISORY: English 250 and English 260.

10030 Lec SS205 Kier D 3.2 3.0 TR 0810-0930

HIST 12 Cultural History of the Mexican American

Transferable: CSU, UC; CSU-GE:C2, D3, D6, IGEC:3B, 4F; GAV-GE:D2, F

The Mexican American experience as influenced by society in the United States. Emphasis will be on the historical and contemporary contributions made by the Indian, Spanish, Mexican, and Mexican American. Emphasis will also be on the social, economic, and political milieu of the Mexican American within the context of the American society. This course has the option of a letter grade or pass/no pass. ADVISORY: Eligible for English 250 and English 260.

10016 Lec SS214 Luna E 3.2 3.0 MW 1250-0210

HIST 21 Ancient Americas: A History through Art

Transferable: CSU, UC; CSU-GE:C1, C2, IGEC:3A; GAV-GE:C2, F

A critical survey of history through the arts of pre-Columbian natives of North, Central and South America. The course will cover major societies and events from the appearance of major civilizations through the initial colonization efforts of European nations. Due to the distinct history of the Americas, this course uses the arts - architecture, sculpture, ceramics and painting, among others - of ancient societies as a primary source material. This course has the option of a letter grade or pass/no pass. This course is also listed as ART 21. ADVISORY: Eligible for English 250.

10481 Lec HOL5 STAFFS 3.2 3.0 MW 0230-0350
Above class meets at the Hollister Briggs site.

HUMANITIES

HUM 3 Introduction to the Cinema

Transferable: CSU, UC; CSU-GE:C2, IGEC:3B; GAV-GE:C2

This course provides an introduction to the cinema. It includes a view of the inventors and the technological developments that led to the modern motion picture; an historical perspective on the growth and development of cinema including significant films that contributed to its establishment as an art form, a study of film genres such as the comedy, the musical, and the western; the technology of image and sound; and a look at the basic techniques of filmmakers when they attempt to convey meaning. ADVISORY: Eligible for English 250 and 260.

10237 Lec SS214 Richards G 3.2 3.0 MW 1120-1240

10238 Lec SS214 Richards G 3.2 3.0 TR 1250-0210

HUM 4 Introduction to American Cinema

Transferable: CSU, UC; CSU-GE:C2, IGEC:3B; GAV-GE:C2

This introductory course in film studies is a survey of the American film industry as an art form, as an industry, and as a system of representation and communication. The course explores how Hollywood films work technically, aesthetically, and culturally to reinforce and challenge America's national self-image. ADVISORY: English 440

10239 ONLINE Richards G 3.0

You must have an email account to take this course. Start your course by going to www.gavilan.edu/disted. Unless you have made prior arrangements with the instructor, you MUST log on by 11:59 pm on the first day of the semester. Late adds must login within 24 hours of adding this course. If you miss the deadline you may be dropped. For help, contact your instructor or email disted@gavilan.edu.

HUM 23 Independent Study

Transferable: CSU

Designed to afford selected students specialized opportunities for exploring areas at the independent study level. The courses may involve extensive library work, research in the community, or special projects. May be repeated until six units of credit are accrued. This course has the option of a letter grade or pass/no pass. REQUIRED: The study outline prepared by the student and the instructor must be filed with the department and the dean.

10235 Ind HU111 Richards G 1.0

10236 Ind HU111 Richards G 2.0

CRN Type Room Instructor Hrs. Units Days Begin-End

INDUSTRIAL TECHNOLOGY

IT 115 Industrial Safety

Transferable: CSU

This course is an introduction to the construction industry. It will cover the basic skill sets required to earn an entry-level position in various trades in construction. Students will learn basic math, vocabulary, blue print reading and safety skills along with the soft skills required to gain employment. This course has the option of a letter grade or pass/no pass. ADVISORY: Eligible for English 250 and English 260.

10800 Lec PB4A Wright D 3.3 3.0 R 0600-0905

Information Science: see CSIS

JAPANESE

JPN 1A Elementary Japanese

Transferable: CSU, UC; CSU-GE:C2; GAV-GE:C2

Beginning course with emphasis on understanding and speaking Japanese; introduction to reading and writing Japanese. This course will also introduce students to Japanese culture and institutions. This course has the option of a letter grade or pass/no pass.

10643 L/L SS111 Sakai T 5.4 5.0 MW 0230-0455
ARR TBA 2.0

JOURNALISM

JOUR 10 Mass Media and Society

Transferable: CSU, UC; CSU-GE:C2, D0, IGEC:4J; GAV-GE:C2, D2; CAN:JOUR4

This course helps students understand the 20th century revolution in mass media by focusing on the history, economics and social impact of the newspaper, book publishing, magazine, film, television, public relations, advertising and music industries. Students will study audience, propaganda and mass communication theory; and discuss new technology, ethnic media in the United States, ethical issues and attempts to regulate or control the media. Honors students will complete more in-depth analysis of media issues and will finish a media-related research project. This course is also listed as SOC 10. This course has the option of a letter grade or pass/no pass. ADVISORY: English 250, English 260.

10051 Lec SS205 Janes J 3.2 3.0 MW 0810-0930

JOUR 16A Writing for Media

Transferable: CSU; GAV-GE:C1; CAN:JOUR2

Fundamentals of journalistic writing and analysis of news values and news writing. Stresses organization and structure of news stories; the language and style of news writing; the basic lead and story types for print and broadcast media. ADVISORY: Typing skill; English 1A eligibility.

10599 Lec HU106 Foley J 3.2 3.0 MW 0810-0930

JOUR 18A Working on the Newspaper

Transferable: CSU; GAV-GE:C1

Students interview, write, photograph and do computer assisted design and graphics for the college newspaper, The Gavilan Press. In doing this, they provide the community with an important first amendment forum, learn and educate about the first amendment rights and responsibilities, and acquire journalistic skills, ethics, and habits. ADVISORY: Eligible for English 1A. Typing ability.

10605 Lab HU106 Janes J 2.6 2.0 MW 0230-0335

10613 Lab HU106 Janes J 5.4 3.0 MW 0230-0455

10614 Lab HU106 Janes J 5.4 4.0 MW 0230-0455
ARR TBA 3.3

10615 Lab HU106 Janes J 5.4 5.0 MW 0230-0455
ARR TBA 6.6

CRN Type Room Instructor Hrs. Units Days Begin-End

JOUR 18B Working on the Newspaper

Transferable: CSU; GAV-GE:C1

Students interview, write, photograph and do computer assisted design and graphics for the college newspaper, The Gavilan Press. In doing this, they provide the community with an important first amendment forum, learn and educate about the first amendment rights and responsibilities and acquire journalistic skills, ethics and habits. ADVISORY: Journalism 18A.

10616	Lab	HU106	Janes J	2.6	2.0	MW	0230-0335
10617	Lab	HU106	Janes J	5.4	3.0	MW	0230-0455
10619	Lab ARR	HU106	Janes J TBA	5.4 3.3	4.0	MW	0230-0455
10621	Lab ARR	HU106	Janes J TBA	5.4 6.6	5.0	MW	0230-0455

JOUR 18C Working on the Newspaper

Transferable: CSU; GAV-GE:C1

Students interview, write, photograph and do computer assisted design and graphics for the college newspaper, The Gavilan Press. In doing this, they provide the community with an important first amendment forum, learn and educate about the first amendment rights and responsibilities and acquire journalistic skills, ethics and habits. ADVISORY: Journalism 18B.

10623	Lab	HU106	Janes J	2.6	2.0	MW	0230-0335
10625	Lab	HU106	Janes J	5.4	3.0	MW	0230-0455
10626	Lab ARR	HU106	Janes J TBA	5.4 3.3	4.0	MW	0230-0455
10628	Lab ARR	HU106	Janes J TBA	5.4 6.6	5.0	MW	0230-0455

JOUR 18D Working on the Newspaper

Transferable: CSU; GAV-GE:C1

Students interview, write, photograph and do computer assisted design and graphics for the college newspaper, The Gavilan Press. In doing this, they provide the community with an important first amendment forum, learn and educate about the first amendment rights and responsibilities and acquire journalistic skills, ethics and habits. ADVISORY: Journalism 18C.

10632	Lab	HU106	Janes J	2.6	2.0	MW	0230-0335
10633	Lab	HU106	Janes J	5.4	3.0	MW	0230-0455
10634	Lab ARR	HU106	Janes J TBA	5.4 3.3	4.0	MW	0230-0455
10635	Lab ARR	HU106	Janes J TBA	5.4 6.6	5.0	MW	0230-0455

JOUR 22 Field Work and Service

Transferable: CSU; GAV-GE:C1

Supervised field work within the college and with local agencies. Students serve in useful group activities in leadership roles prescribed for them by faculty or community agencies. A maximum of six units may be completed. This is a pass/no pass course. REQUIRED: Learning contracts must be filled out and signed by the student and the supervising instructor.

10640	Fld Ex	HU106	Janes J		.5		
-------	--------	-------	---------	--	----	--	--

JOUR 23 Independent Study

Transferable: CSU; GAV-GE:C1

Designed to afford selected students specialized opportunities for exploring areas at the independent study level. The courses may involve extensive library work, research in the community, or special projects. May be repeated until six units of credit are accrued. This course has the option of a letter grade or pass/no pass. REQUIRED: The study outline prepared by the student and the instructor must be filed with the department and the dean.

10642	Ind	HU106	Janes J		2.0		
-------	-----	-------	---------	--	-----	--	--

Sign up early!



Looking for work in the construction fields?

IT 115
Industrial Safety
 Thursday evenings, 6:00 -9:05 pm
 CRN 10800

- Learn:
- ⇒ Entry level math
 - ⇒ field related vocabulary
 - ⇒ safety skills

To take this class for Gavilan credit, register in person or online.
 For information about ROP noncredit registration call 408-848-4816.



Make Something Happen!

Learn Something New!

- ◆ Work in print and online
- ◆ Earn units toward a Media Arts Degree
- ◆ Learn new writing, research and design skills
- ◆ Get published and build a portfolio of your work
- ◆ Gain work experience that will help you land a good job
- ◆ Become part of a team
- ◆ Support free speech at Gavilan College!

JOUR 10 Mass Media & Society

What impact do mass media have on our society and on our world?

JOUR 18A-D Working on the Newspaper

Become a staff member of The Gavilan Press, Gavilan's independent student newspaper, in print and online!

The Final Word!

Look for the Final Exams schedule on page 133 of this schedule.

CRN Type Room Instructor Hrs. Units Days Begin-End

JOUR 190 Occupational Work Experience/Journalism

Transferable: CSU

The application of learned theory, knowledge, and skills to a practical job setting related to the student's educational/occupational goal. Employment must be directly related to the student's college educational/occupational goal. Periodic interviews of the students and employers or their representatives will be required. Each student shall be assisted in the development of individualized performance objectives, toward which the learning experience shall be directed. REQUIRED: Enrollment in a minimum of seven (7) units, including Cooperative Work Experience, during regular semesters; enrollment in at least one other class in summer session.

Mandatory course orientation for the following classed will be conducted Tuesday October 6, 2009 from 530 pm-630 pm the North/South Lounge, Wednesday, October 7, 2009 from 430 pm -530 pm in the North/South Lounge and Thursday October 8, 2009 from 8 am to 9 am in the North/South Lounge. Students need to attend one of the three meetings. Please contact Susan Sweeney, CWVE Coordinator at (408) 848-4813 for more information.

10864	Wrk Ex	LI101A	Sweeney S	1.0
10865	Wrk Ex	LI101A	Sweeney S	2.0
10973	Wrk Ex	LI101A	Sweeney S	3.0
10974	Wrk Ex	LI101A	Sweeney S	4.0

JPA Fire 10865 Wrk Ex LI101A Sweeney S 2.0

Technology
and

JPA Law Enforcement
see ad below:



Careers in

Law Enforcement • Fire Technology

Probation Officer • Dispatcher

Corrections Officer • Juvenile Hall Counselor

Gavilan College is a member of the South Bay Regional Public Safety Training consortium. This consortium is funded by all colleges regionally to provide vocational specific training which may require special facilities, special training conditions or is presented outside of the schedules of regular college classes. For more information call 408-270-6458.

Law Enforcement: see also Administration of Justice

LIBRARY

LIB 3 Research Skills

Transferable: CSU

Research and evaluation skills using the Internet and other electronic resources, as well as traditional printed materials. Also listed as CSIS 3. This course has the option of a letter grade or pass/no pass. May be repeated once for credit. ADVISORY: Eligible for English 250 and 260.

10806	ONLINE	Meador S	2.0
-------	--------	----------	-----

10/14/09 - 12/08/09 You must have an email account to take this course. Start your course by going to www.gavilan.edu/disted. Unless you have made prior arrangements with the instructor, you MUST log on by 11:59 pm on the first day of class. Late adds must login within 24 hours of adding this course. If you miss the deadline you may be dropped. For help, contact your instructor or email disted@gavilan.edu.

Don't be confused!
There are new codes
to designate days

R means Thursday!
U means Sunday!

CRN Type Room Instructor Hrs. Units Days Begin-End

LIB 6 Web Page Authoring I

Transferable: CSU; GAV-GE:E2

A introduction to using Hypertext Mark-Up Language (HTML) and Extensible HTML (XHTML) to create web pages which can be uploaded and displayed on the World Wide Web. Students will use HTML/XHTML to create web pages with text in various sizes and colors, links to other sites, background color or patterns, graphics, tables, and mailto links. Principles of design and color as they apply to screen presentations will be included. This course has the option a letter grade or pass/no pass. May be repeated three times for credit. Also listed as CSIS 6 and DM 6. ADVISORY: CSIS 1 or CSIS 2 or CSIS/LIB 3 advised.

10313	ONLINE	Howell J	2.0
-------	--------	----------	-----

09/03/09 - 10/26/09 You must have an email account to take this course. Start your course by going to www.gavilan.edu/disted. Unless you have made prior arrangements with the instructor, you MUST log on by 11:59 pm on the first day of class. Late adds must login within 24 hours of adding this course. If you miss the deadline you may be dropped. For help, contact your instructor or email disted@gavilan.edu.

10317	ONLINE	Howell J	2.0
-------	--------	----------	-----

10/19/09 - 12/12/09 You must have an email account to take this course. Start your course by going to www.gavilan.edu/disted. Unless you have made prior arrangements with the instructor, you MUST log on by 11:59 pm on the first day of class. Late adds must login within 24 hours of adding this course. If you miss the deadline you may be dropped. For help, contact your instructor or email disted@gavilan.edu.

MANAGEMENT

MGMT 102 Retail Management

Transferable: CSU

Principles and practices used in management of retail businesses such as foods, motels, service stations, and direct channels. Includes site selection, layout, organization, staffing, positioning, customer service, promotional techniques, and all aspects of the critical buying function. This course has the option of a letter grade or pass/no pass. ADVISORY: Eligible for English 250 and English 260.

10893	Lec	HOL4	Kurtz S	3.3	3.0	W	0600-0905
-------	-----	------	---------	-----	-----	---	-----------

Above class meets at the Hollister Briggs site.

MARKETING

MKTG 100 Principles of Marketing

Transferable: CSU

An introduction to the economic and social problems involved with moving goods and services from the producer to the consumer. This course covers topics such as marketing institutions, channels of distribution, pricing, and government relationships. This course has the option of a letter grade or pass/no pass. ADVISORY: Eligible for English 250 and English 260.

10949	Lec	MHG4	Taylor J	3.3	3.0	U	0400-0705
-------	-----	------	----------	-----	-----	---	-----------

Above class meets at Morgan Hill Community site.

MASS COMMUNICATIONS & TELEVISION

see also JOURNALISM



MCTV 16 Television History and Practice

Transferable: CSU, UC

This course examines theories, history and development of television technology and current distribution practices. Programming genres and production techniques are analyzed, evaluated and compared with other societies as tools of mass communication. This course is also listed as THEA 16. ADVISORY: Eligible for English 250 and 260.

10953	Lec	LI140	Abad M	3.2	3.0	MW	1120-1240
-------	-----	-------	--------	-----	-----	----	-----------



MCTV 17A Television and Video Workshop

Transferable: CSU, UC

An introduction to television and video technology, including pre-production, production and post-production techniques such as: camera work, studio equipment, lighting, audio plus off-line and on-line editing. This course is also listed as THEA 17A. ADVISORY: Theatre Arts 16 Intro to TV or consent of instructor.

10954	L/L	LI140	Frazier J	5.4	3.0	TR	1250-0315
-------	-----	-------	-----------	-----	-----	----	-----------

Classroom Locations: Refer to "How to Use This Schedule" on page 5.

CRN Type Room Instructor Hrs. Units Days Begin-End



MCTV 17B Television and Video Workshop

Transferable: CSU, UC

Emphasis placed on production and post-production techniques in video production. Student knowledge and skills are increased by participating in live to tape projects. May be repeated twice for credit. This course is also listed as THEA 17B. ADVISORY: Completion of Theatre Arts 17A.

10955 Lec LI140 Frazier J 5.4 3.0 TR 1250-0315



MCTV 19 Television and Film Acting

Transferable: CSU, UC

Theory and practice of acting for film and television. Students will learn basic performance techniques for the camera. Learning experiences include projects in broadcasting, reporting, commercials, public service announcements (psa), comedy and drama. This course has the option of a letter grade or pass/no pass. May be repeated three times for credit. This course is also listed as THEA 19.

10956 L/L LI140 STAFFS 3.2 3.0 TR 1120-1240

MATHEMATICS

MATH 1A Single-Variable Calculus and Analytic Geometry

Transferable: CSU, UC; CSU-GE:B4, IGETC:2A; GAV-GE:B4; CAN:MATH18, MATH SEQ BC

Limits and continuity, analyzing the behavior and graphs of functions, derivatives, implicit differentiation, higher order derivatives, related rates and optimization word problems, Newton's Method, Fundamental Theorem of Calculus, and definite and indefinite integrals. PREREQUISITE: Mathematics 10 or Mathematics 8B with a grade of 'C' or better.

10364 Lec SS206 Wagman K 4.8 4.0 MWF 1250-0210

MATH 1B Single-Variable Calculus and Analytic Geometry

Transferable: CSU, UC; CSU-GE:B4, IGETC:2A; GAV-GE:B4; CAN:MATH20, MATH SEQ BC

This course is a standard second semester Calculus course covering methods of integration, applications of the integral, differential equations, parametric and polar equations, and sequences and series. PREREQUISITE: Mathematics 1A with a grade of 'C' or better.

10365 Lec PH102 Dachkova E 4.6 4.0 TR 0600-0805

MATH 5 Introduction to Statistics

Transferable: CSU, UC; CSU-GE:B4, IGETC:2A; GAV-GE:B4; CAN:STAT2

Descriptive analysis and presentation of either single-variable data or bivariate data, probability, probability distributions, normal probability distributions, sample variability, statistical inferences involving one and two populations, analysis of variance, linear correlation and regression analysis. Statistical computer software will be extensively integrated as a tool in the description and analysis of data. PREREQUISITE: Mathematics 233 with a grade of 'C' or better. The instructor will be using and supporting a TI-83 Plus graphing calculator in all classroom demonstrations.

10432 L/L PH103 Dwyer M 3.2 3.0 TR 1120-1240
L/L PH101 Dwyer M 1.6 F 1120-1210

10431 L/L PH103 Jukl H 2.3 3.0 M 0230-0435
L/L PH103 Jukl H 1.3 W 0230-0335
L/L PH101 Jukl H 1.0 W 0345-0435

10433 L/L CH102 Littig A 4.6 3.0 TR 0600-0805

10434 L/L MHG13 Viarengo A 2.3 3.0 M 0600-0805
L/L MHG8 Viarengo A 2.3 W 0600-0805
Above class meets at Morgan Hill Community site.

10435 ONLINE Haussermann J 3.0



You must have an email account to take this course. Start your course by going to www.gavilan.edu/disted. Unless you have made prior arrangements with the instructor, you MUST log on by 11:59 pm on the first day of the semester. Late adds must login within 24 hours of adding this course. If you miss the deadline you may be dropped. For help, contact your instructor or email disted@gavilan.edu.

Be Aware

You MAY NOT take courses that overlap (courses that meet at the same day and time)

NEW PROGRAM

Retail Management Certificate Coming Soon! (pending approval)



The certificate is composed of ten courses which may be offered in a combination of face to face and distance learning formats. Future courses include:



- Principles of Marketing
- Introduction to Supervision
- Management Techniques
- Human Resources Management
- Leadership/Human Relations in Business

MKTG 100 - Principles of Marketing is the first course in the certificate.

CRN 10949 Sunday 4-7:05 pm in Morgan Hill

Contact the office of Technical and Public Services at 408-848-4719 for additional information.

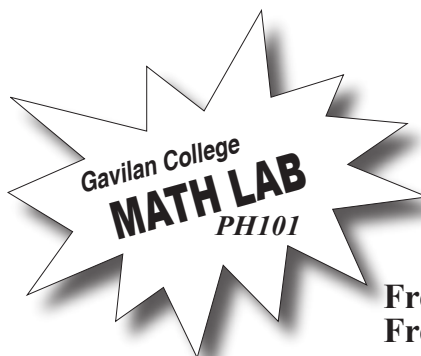

FREE TUTORING!

Services for Gavilan Students:

Free Tutoring for MATH
Free Computer Assistance

For daily schedule or for free Math downloads, check our website - <http://www.gavilan.edu/math/mathlab/index.html/>

Staffed by the Math Department

CRN Type Room Instructor Hrs. Units Days Begin-End

MATH 7 Finite Mathematics

Transferable: CSU, UC; CSU-GE:B4, IGETC:2A; GAV-GE:B4; CAN:MATH12

Systems of linear equations and matrices, introduction to linear programming, finance, counting techniques and probability, properties of probability and applications of probability. PREREQUISITE: Mathematics 233 with a grade of 'C' or better.

10436 Lec LS102 Lockhart L 3.2 3.0 TR 0810-0930

MATH 8A First Half of Precalculus

Transferable: CSU, UC; CSU-GE:B4, IGETC:2A; GAV-GE:B4

Math 8A prepares the student for the study of calculus by providing important skills in algebraic manipulation, interpretation, and problem solving at the college level. Topics will include basic algebraic concepts, complex numbers, equations and inequalities of the first and second degree, functions, and graphs, linear and quadratic equations, polynomial functions, exponential and logarithmic functions, systems of equations, matrices and determinants, right triangle trigonometry, and the Law of Sines and Cosines. PREREQUISITE: Mathematics 233 with a grade of 'C' or better. The instructor will be using and supporting TI-83 Plus graphing calculator in all classroom demonstrations.

10437 Lec SS206 Nari J 4.2 4.0 TRF 0945-1055

10438 Lec PH103 Lee R 4.2 4.0 MWF 1250-0200

CRN Type Room Instructor Hrs. Units Days Begin-End

MATH 8B Second Half of Precalculus

Transferable: CSU, UC; CSU-GE:B4, IGETC:2A; GAV-GE:B4

Math 8B prepares students for the study of calculus by providing important skills in algebraic manipulation, interpretation, and problem solving at the college level. Topics will include trigonometric functions, identities, inverse trigonometric functions, and equations; applications of trigonometry, vectors, complex numbers, polar and parametric equations; conic sections; sequences, series, counting principles, permutations, mathematical induction; analytic geometry, and an introduction to limits. PREREQUISITE: Mathematics 8A with a grade of 'C' or better. ADVISORY: Math 208 Survey of Practical Geometry.

10439	Lec	CH102	Maisch F	4.6	4.0	MW	0600-0805
-------	-----	-------	----------	-----	-----	----	-----------

MATH 12 Mathematics for Elementary Teachers

Transferable: CSU, UC; CSU-GE:B4; GAV-GE:B4

This course is intended for students preparing for a career in elementary school teaching. Emphasis will be on the structure of the real number system, numeration systems, elementary number theory, and problem solving techniques. Technology will be integrated throughout the course. PREREQUISITE: High School Geometry and Math 233 (Intermediate Algebra), or, Math 208 (Plane Geometry) and Math 233 (Intermediate Algebra). All courses must be completed with a grade of 'C' or better.

10363	Lec	MHG10	Kercheval S	3.3	3.0	M	0630-0935
Above class meets at Morgan Hill Community site.							

MATH 201B Math for Science and Engineering

Transferable: No

This course will provide a combination of math study skills, introduction to scientific equipment and technology for mathematics, collection and analysis of data from various branches of science, one or more field trips, investigation of science careers and program choices at the transfer level. COREQUISITE: Enrollment in appropriate section of Math 233 which is part of a learning community.

10366	Lec	SS206	Dresch M	1.0	1.0	F	1120-1210
This class is part of a Learning Community. If you enroll in this class you must also enroll in Math 233, CRN #10400.							

MATH 205 Elementary Algebra

Transferable: No; GAV-GE:B4

This course is a standard beginning algebra course, including algebraic expressions, linear equations and inequalities in one variable, graphing, equations and inequalities in two variables, integer exponents, polynomials, rational expressions and equations, radicals and rational exponents, and quadratic equations. Mathematics 205, 205A and 205B, and 206 have similar course content. This course may not be taken by students who have completed Mathematics 205B or 206 with a grade of "C" or better. This course may be taken for Mathematics 205B credit (2.5 units) by those students who have successfully completed Mathematics 205A with a grade of "C" or better. PREREQUISITE: MATH 402 with a grade of 'C' or better or assessment test recommendation.

10367	Lec	PH103	Knight R	5.0	5.0	MTWRF	0810-0905
10369	Lec	PH103	Dresch M	5.2	5.0	MTWR	0945-1050

↳ continued

CRN Type Room Instructor Hrs. Units Days Begin-End

10372	Lec	CH105	Wagman K	5.2	5.0	MTWR	1120-1225
10379	Lec	LS101	Kim D	2.6	5.0	MW	1250-0155
	Lec	PH103	Kim D	2.6		TR	1250-0155
10370	Lec	CH105	Fassler J	5.2	5.0	MTWR	1250-0155
10371	Lec	HOL5	Knight R	5.2	5.0	MTWR	1250-0155
Above class meets at the Hollister Briggs site.							
10368	Lec	MHG13	Kercheval S	5.2	5.0	MTWR	1250-0155
Above class meets at Morgan Hill Community site.							
10373	Lec	CH105	Ward S	5.2	5.0	MTWR	0410-0515
10374	Lec	HOL4	Bates R	5.4	5.0	TR	0600-0825
Above class meets at the Hollister Briggs site.							
10375	Lec	MHG13	Butterworth Y	5.4	5.0	TR	0600-0825
Above class meets at Morgan Hill Community site.							

MATH 205A First Half of Elementary Algebra

Transferable: No; GAV-GE:B4

This course is the first half of the Elementary Algebra course. It will cover signed numbers, evaluation of expressions, ratios and proportions, solving linear equations, and applications. Graphing of lines, the slope of a line, graphing linear equations, solving systems of equations, basic rules of exponents, and operations on polynomials will be covered. PREREQUISITE: Effective Fall 2005: MATH 402 with a grade of 'C' or better or assessment test recommendation. ADVISORY: Concurrent enrollment in Guidance 563A is advised.

10380	Lec	LS101	Lawson D	4.2	2.5	MWF	0810-0920
10381	Lec	PH102	Lockhart L	4.2	2.5	TRF	1250-0200
10382	Lec	PH102	Buchanan M	9.2	2.5	MTWR	0230-0435
09/01/09 - 10/24/09							
10384	Lec	PH103	Arid A	4.6	2.5	MW	0600-0805

MATH 205B Second Half of Elementary Algebra

Transferable: No; GAV-GE:B4

This course contains the material covered in the second half of the Elementary Algebra Course. It will cover factoring, polynomials, solving quadratic equations by factoring, rational expressions and equations, complex fractions, radicals and radical equations, solving quadratic equations by completing the square and the quadratic formula. Application problems are integrated throughout the topics. PREREQUISITE: Math 205A with a grade of 'C' or better. ADVISORY: Concurrent enrollment in Guidance 563B is advised.

10386	Lec	LS103	Fassler J	4.2	2.5	MWF	1120-1230
10387	Lec	PH102	Buchanan M	9.2	2.5	MTWR	0230-0435
10/26/09 - 12/19/09							

Be Aware
If your goal is a MULTIPLE SUBJECT CREDENTIAL,
you may need MATH 12, Math for Elementary
Teachers.

Close Encounters with Math and Science



- Have you ever wondered how math applies to real world problems?
- Are you looking for a supportive environment to help with your math?
- Have you ever thought about a career in science, engineering or math, but doubted your ability to get through the math class required?
- Would you like to finally understand how to solve word problems?

Then this Learning Community is for you! Sign up for:

MATH 201B Math for Science and Engineering

10366	Lec	SS206	Dresch M	1.0	1.0	F	1120-1210
-------	-----	-------	----------	-----	-----	---	-----------

MATH 233 Intermediate Algebra

10400	Lec	SS206	Dresch M	5.2	5.0	MTWR	1120-1225
-------	-----	-------	----------	-----	-----	------	-----------



For more information about this exciting new program, contact math instructor Marla Dresch in LS112, call (408) 846-4915 or email mdresch@gavilan.edu.

CRN Type Room Instructor Hrs. Units Days Begin-End

MATH 233 Intermediate Algebra

Transferable: No; GAV-GE:B4

Review of basic concepts, linear equations and inequalities, graphs and functions, systems of linear equations, polynomials and polynomial functions, factoring, rational expressions and equations, roots, radicals, and complex numbers, solving quadratic equations, exponential and logarithmic functions, and problem solving strategies. Mathematics 233, 233A, and 233B have similar course content. This course may not be taken by students who have completed Mathematics 233B with a grade of 'C' or better. This course may be taken for Mathematics 233B credit (2.5) units by those students who have successfully completed Mathematics 233A with a grade of 'C' or better. PREREQUISITE: Mathematics 205 or Mathematics 205A and 205B or Mathematics 206 with a grade of 'C' or better. The instructor will be using and supporting TI-83 Plus graphing calculator in all classroom demonstrations.

LEARNING COMMUNITY MATH 233 CLASS:

10400 Lec SS206 Dresch M 5.2 5.0 MTWR 1120-1225
This class is part of a Learning Community. If you enroll in this class you must also enroll in Math 201B, CRN # 10366.

10388 Lec CH102 Lee R 5.0 5.0 MTWRF 0810-0905

10390 Lec SS206 Dwyer M 2.6 5.0 MW 0945-1050
CH105 TR 0945-1050

10392 Lec PH103 Kim D 3.2 5.0 MW 1120-1240
Lec PH103 Kim D 2.0 F 1040-1240

10395 Lec CH102 Nari J 5.2 5.0 MTWR 1250-0155

10389 Lec MHG10 Potter R 5.2 5.0 MTWR 1250-0155
Above class meets at Morgan Hill Community site.

10391 Lec HOL1 Malokas J 5.2 5.0 MTWR 1250-0155
Above class meets at the Hollister Briggs site.

10396 Lec SS206 Grover M 5.2 5.0 MTWR 0410-0515

10397 Lec PH103 Grover M 5.4 5.0 TR 0600-0825

MATH 233A First Half of Intermediate Algebra

Transferable: No

The course will start with a review of basic concepts and then cover the following topics with an emphasis on applications and problem solving strategies: solving linear equations; solving linear, compound, and absolute value inequalities; equations and graphs of lines; functions and function notation including composition of functions; solving systems of linear equations and inequalities; an introduction to matrices and Cramer's rule; operations with polynomials; factoring polynomials; and solving polynomial equations. PREREQUISITE: Completion of Mathematics 205 or the equivalent with a grade of 'C' or better.

10401 Lec CH105 Bass J 4.2 2.5 TRF 0810-0920

10403 Lec CH102 Fuller G 4.2 2.5 MWF 0945-1055

10412 Lec LS101 Wolff L 4.6 2.5 MW 0230-0435
09/01/09 - 10/24/09

10412 Lec CH102 Wolff L 4.6 TR 0230-0435

10410 Lec LS101 Lockhart L 4.6 2.5 TR 0600-0805

MATH 233B Second Half of Intermediate Algebra

Transferable: No

This course will start with a review factoring polynomials, and then cover the following topics with an emphasis on applications and problem solving strategies: solving polynomial equations by factoring; adding, subtracting, multiplying, dividing and simplifying rational expressions and solving rational equations; adding, subtracting, multiplying, dividing and simplifying roots, radicals and complex numbers and solving radical equations; the various methods of solving quadratic equations and inequalities; graphing quadratic functions; and working with exponential and logarithmic functions, equations and expressions. PREREQUISITE: Completion of MATH 233A with a grade of 'C' or better.

10416 Lec LS102 Dachkova E 4.2 2.5 TRF 1120-1230

10414 Lec LS101 Wolff L 4.6 2.5 MW 0230-0435
CH102 Wolff L 4.6 TR 0230-0435

10/26/09 - 12/19/09

**Gavilan College
Overview of Math Courses**

Grade of "C" or better required in order to progress to the next course

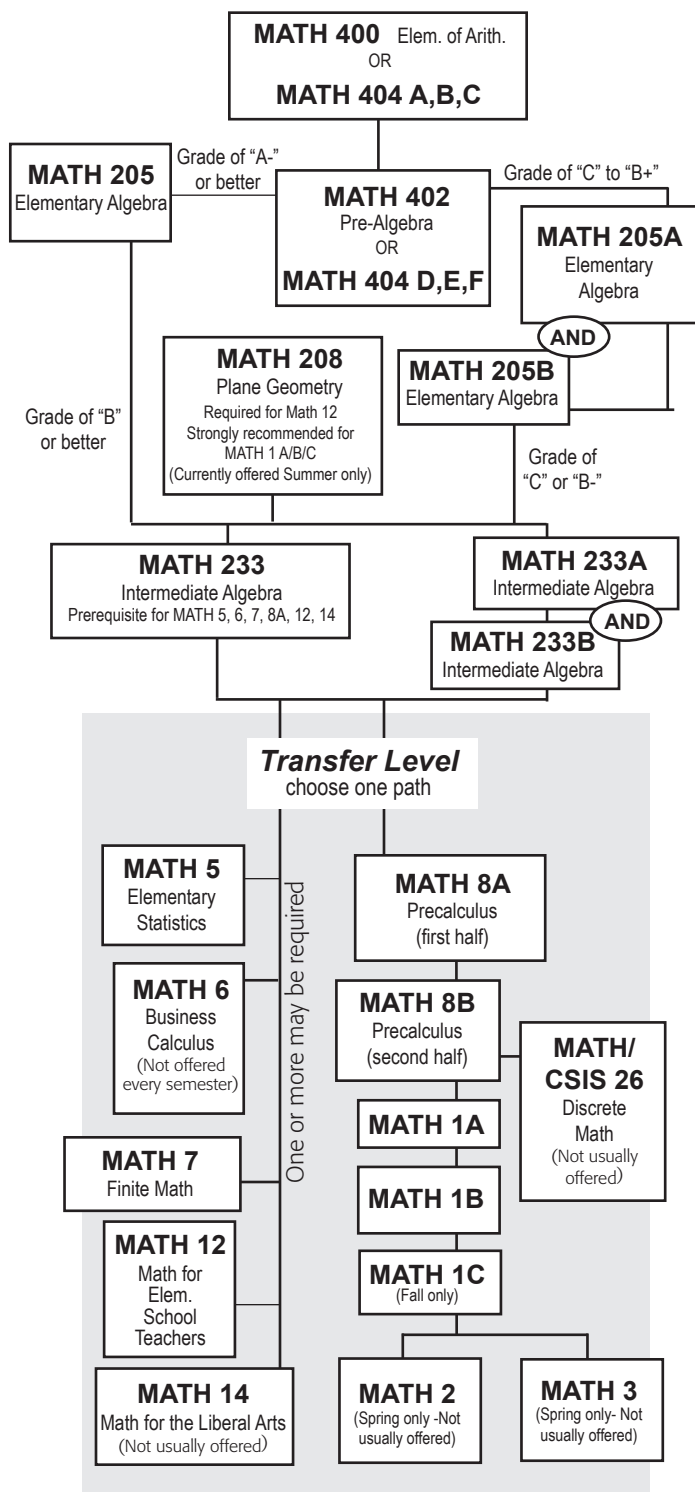

Multiple measures will be considered to determine your final course. Consult with a counselor to select the appropriate course.

Have you met the prerequisite? **It's required!**

CRN Type Room Instructor Hrs. Units Days Begin-End

MATH 400 Elements of Arithmetic

Transferable: No

Essential arithmetic operations, whole numbers, integers, fractions, decimals, ratio, proportion, percent, applications of arithmetic, and critical thinking, as well as math-specific study skills. Units earned in this course do not count toward the associate degree and/or other certain certificate requirements.

10417	L/L	SS206	Fuller G	4.0	3.0	MTWR	0810-0905
10418	L/L	LS103	Potter R	3.2	3.0	MW	0945-1105
	L/L	LS103	Potter R	1.0		F	0945-1035
10419	L/L	SS206	Arid A	4.6	3.0	TR	0600-0805

MATH 402 Pre-Algebra

Transferable: No

This course covers operations with integers, fractions and decimals and associated applications, percentages, ratio, and geometry and measurement, critical thinking and applications. Elementary algebra topics such as variables, expressions, and solving equations are introduced. PREREQUISITE: Completion of Math 400 with a 'C' or better, or assessment test recommendation.

10420	L/L	PH102	STAFF S	4.0	3.0	MTWR	0810-0905
10421	L/L	LS101	Lockhart L	3.2	3.0	TR	1120-1240
	L/L	LS101	Lockhart L	1.0		F	1200-1250
10422	L/L	CH105	Ward S	4.2	3.0	TRF	0230-0340
10423	L/L	PH102	Littig A	4.6	3.0	MW	0600-0805

MATH 404A-G Self-Paced Basic Math

Transferable: No

This course is a remedial, modular, self-paced course. Application and critical thinking skills are developed in each module. Module A covers operations with whole numbers, equivalent fractions, multiplying and dividing fractions. Module B covers adding and subtracting fractions, and operations with decimals. Module C covers ratio and proportion, percent, and units of measurement. Module D reviews fractions, decimals, percentages, and covers operations with integers, and working with variables. Module E covers real numbers, fractions, exponents, scientific notation, and order of operations. Module F covers expressions, polynomials, and equations. Module G covers geometric figures, perimeter and area, surface area and volume, triangles and parallelograms, and similar figures. This course has the option of a letter grade or pass/no pass. This course involves both lecture and hands-on computer assisted software. All sections are open for late registration. Math 404 A-C is the equivalent of Math 400.

These classes involve both lecture and hands-on computer components. All sections are open for late registration.

MATH 404A	10424	L/L	PH101	Dachkova E	5.6	1.0	TR	1250-0320
MATH 404B	10425	L/L	PH101	Dachkova E	5.6	1.0	TR	1250-0320
MATH 404C	10426	L/L	PH101	Dachkova E	5.6	1.0	TR	1250-0320
MATH 404D	10427	L/L	PH101	Dachkova E	5.6	1.0	TR	1250-0320
MATH 404E	10428	L/L	PH101	Dachkova E	5.6	1.0	TR	1250-0320
MATH 404F	10429	L/L	PH101	Dachkova E	5.6	1.0	TR	1250-0320
MATH 404G	10430	L/L	PH101	Dachkova E	5.6	1.0	TR	1250-0320

Medical Terminology: see Business

Don't forget

A counselor's signature is required if you take over 17.99 units (spring/fall) or over 5.99 units (summer).

You do not need a counselor's signature to register for a class with a prerequisite that was successfully completed at Gavilan.

CRN Type Room Instructor Hrs. Units Days Begin-End

MUSIC

MUS 1A Music History and Literature

Transferable: CSU, UC; CSU-GE:C1; IGETC:3A; GAV-GE:C1; CAN:MUS8

A survey of the development of music in western civilization including representative composers from the Medieval to the present. Music 1A will study the music and styles from the Medieval to the Romantic period. ADVISORY: Eligible for English 250 and English 260.

10677	Lec	AL101	Juncker A	3.2	3.0	TR	0810-0930
-------	-----	-------	-----------	-----	-----	----	-----------

MUS 3A Harmony - Theory - Musicianship

Transferable: CSU, UC; CSU-GE:C1; GAV-GE:C1

Fundamentals of music, beginning harmony. ADVISORY: Must be taken in sequence.

10690	L/L	AL101	Juncker A	4.6	4.0	MW	1120-0125
-------	-----	-------	-----------	-----	-----	----	-----------

MUS 3B Harmony - Theory - Musicianship

Transferable: CSU, UC; GAV-GE:C1

Fundamentals of music, beginning harmony. ADVISORY: Must be taken in sequence.

10691	L/L	AL101	Juncker A	4.6	4.0	MW	1120-0125
-------	-----	-------	-----------	-----	-----	----	-----------

MUS 4A Beginning Piano

Transferable: CSU, UC; CSU-GE:C1; GAV-GE:C1

Introduction to music fundamentals and keyboard technique. Development of beginning keyboard skills including note reading in bass and treble clef, fingering, rhythm, key signatures, primary chords and inversions. ADVISORY: Must be taken in sequence.

10692	L/L	AL102	Amirkhanian M	4.6	3.0	MW	0900-1105
10693	L/L	AL102	Amirkhanian M	4.6	3.0	TR	0900-1105
10695	L/L	AL102	Amirkhanian M	3.2	3.0	MW	1120-1240
10694	L/L	AL102	Mello S	4.3	3.0	M	0530-0935

MUS 4B Beginning Piano

Transferable: CSU, UC; GAV-GE:C1

Continuation of Music 4A. ADVISORY: Music 4A

10696	L/L	AL102	Amirkhanian M	3.2	2.0	TR	1120-1240
10697	L/L	AL102	Mello S	4.3	2.0	M	0530-0935

MUS 5A Intermediate Piano

Transferable: CSU, UC; GAV-GE:C1

Development of intermediate keyboard skills through means of scales, chords, and technical studies. Continuation of music fundamentals and beginning keyboard harmony; introduction of easier classical and standard piano literature. ADVISORY: Music 4B

10698	L/L	AL108	Amirkhanian M	3.2	2.0	TR	1120-1240
10699	L/L	AL102	Mello S	4.3	2.0	M	0530-0935

MUS 5B Intermediate Piano

Transferable: CSU, UC; GAV-GE:C1

Development of intermediate keyboard skills through means of scales, chords and technical studies. Continuation of music fundamentals and beginning keyboard harmony; introduction of easier classical and standard piano literature. ADVISORY: Music 5A

10700	L/L	AL102	Amirkhanian M	3.2	2.0	TR	1120-1240
10701	L/L	AL102	Mello S	4.3	2.0	M	0530-0935

MUS 5C Advanced Piano

Transferable: CSU, UC; GAV-GE:C1

Development of advanced keyboard skills through means of scales, chords and technical studies. Continuation of music fundamentals and keyboard harmony; introduction of moderately difficult classical and standard piano literature. ADVISORY: Music 5B

10702	L/L	AL102	Amirkhanian M	3.2	2.0	TR	1120-1240
10703	L/L	AL102	Mello S	4.3	2.0	M	0530-0935

Classroom Locations: Refer to "How to Use This Schedule" on page 5.

CRN Type Room Instructor Hrs. Units Days Begin-End

MUS 5D Advanced Piano

Transferable: CSU, UC; GAV-GE:C1

Development of advanced keyboard skills through means of scales, chords and technical studies. Continuation of music fundamentals and keyboard harmony; introduction of moderately difficult classical and standard piano literature. ADVISORY: Music 5C

10704	L/L	AL102	Amirkhanian M	3.2	2.0	TR	1120-1240
10705	L/L	AL102	Mello S	4.3	2.0	M	0530-0935

MUS 6 Introduction to World Music

Transferable: CSU, UC; CSU-GE:C1; IGETC:3A; GAV-GE:C1

This course explores a broad and diverse survey of different non Western music cultures, helping students develop listening skills to identify, distinguish and appreciate the elements and richness of each culture's music. The course will cover a rich diversity of styles through informed listening, analysis and discernment of musical elements, form and repertoire. Music of various cultures will be explored, for example: India, China, Japan, the Middle East, Indonesia, Africa, Europe and the Americas.

10706	Lec	AL101	Juncker A	3.2	3.0	MW	0945-1105
-------	-----	-------	-----------	-----	-----	----	-----------

MUS 8A Beginning Voice

Transferable: CSU, UC; GAV-GE:C1

Development of techniques in the art of singing and interpreting serious music in various styles. Study of the basic techniques of tone production, breathing and related skills. Basic repertoire development. ADVISORY: Continues in sequence or by demonstrated proficiency.

10707	L/L	AL101	Pruitt N	3.2	2.0	TR	1250-0210
-------	-----	-------	----------	-----	-----	----	-----------

MUS 8B Beginning Voice

Transferable: CSU, UC; GAV-GE:C1

Development of techniques in the art of singing and interpreting serious music in various styles. Study of the basic techniques of tone production, breathing and related skills. Basic repertoire development. ADVISORY: Music 8A or demonstrated proficiency.

10708	L/L	AL101	Pruitt N	3.2	2.0	TR	1250-0210
-------	-----	-------	----------	-----	-----	----	-----------

MUS 8C Intermediate Voice

Transferable: CSU, UC; GAV-GE:C1

Development of techniques in the art of singing and interpreting serious music in various styles. Study of the basic techniques of tone production, breathing and related skills. Basic repertoire development. ADVISORY: Music 8B or demonstrated proficiency.

10709	L/L	AL101	Pruitt N	3.2	2.0	TR	1250-0210
-------	-----	-------	----------	-----	-----	----	-----------

MUS 8D Intermediate Voice

Transferable: CSU, UC; GAV-GE:C1

Development of techniques in the art of singing and interpreting serious music in various styles. Study of the basic techniques of tone production, breathing and related skills. Basic repertoire development. ADVISORY: Music 8C or demonstrated proficiency.

10710	L/L	AL101	Pruitt N	3.2	2.0	TR	1250-0210
-------	-----	-------	----------	-----	-----	----	-----------

MUS 9A Guitar

Transferable: CSU, UC; GAV-GE:C1

An introduction to playing the guitar. Basic staff notation, correct fingering and chord arpeggios are covered. Emphasis is also placed on developing musical listening skills. Students must provide their own guitars. May be repeated once for credit. ADVISORY: Students must provide their own guitars.

10712	Lab	AL101	Montoya T	3.3	1.0	M	0530-0835
-------	-----	-------	-----------	-----	-----	---	-----------

MUS 9B Guitar

Transferable: CSU, UC; GAV-GE:C1

An introduction to playing the guitar. Basic staff notation, correct fingering and chord arpeggios are covered. Emphasis is also placed on developing musical listening skills. Students must provide their own guitars. May be repeated once for credit. ADVISORY: Music 9A; students must provide their own guitars.

10713	Lab	AL101	Montoya T	3.3	1.0	M	0600-0905
-------	-----	-------	-----------	-----	-----	---	-----------



The most fun you'll ever have in a class!

MUS 12 Vocal Ensemble

- Play:
- Rock & Roll
- Jazz
- Blues
- Top Hits
- Classics
- Your original songs!

MUS 14A Instrumental Ensemble

CRN Type Room Instructor Hrs. Units Days Begin-End

MUS 12 Vocal Ensemble

Transferable: CSU, UC; GAV-GE:C1

The day Vocal Ensemble will focus on individual and group performance of popular and alternative commercial music, and will rehearse and perform with a backup band. The evening Vocal Ensemble will study, rehearse and perform choral music in a broad spectrum of musical genre and styles. Included will be the study of vocal and rehearsal techniques as they relate to ensemble performance. Course may be repeated three times for credit.

10644	L/L	AL101	Juncker A Sotelo S	3.3	2.0	M	0130-0435
-------	-----	-------	-----------------------	-----	-----	---	-----------

MUS 13 Concert Choir

Transferable: CSU, UC; GAV-GE:C1

The Concert Choir will study, rehearse and perform choral music from the 15th century to the present in a variety of musical styles with emphasis on the larger choral works and their preparation for public concert. Course may be repeated three times for credit. ADVISORY: Previous choral experience is preferred but not required. The student should have the ability to match a given pitch.

10671	L/L	AL101	Robb P	3.3	2.0	T	0600-0905
-------	-----	-------	--------	-----	-----	---	-----------

MUS 14A Instrumental Ensemble

Transferable: CSU; GAV-GE:C1

Instruction for the experienced musician with emphasis on the study and performance of a wide variety of musical styles from Renaissance to 20th century music for traditional ensembles, and extensive consideration of contemporary commercial and alternative repertoire, and performance techniques for popular ensembles.

10647	L/L	AL101	Juncker A Sotelo S	3.3	2.0	M	0130-0435
-------	-----	-------	-----------------------	-----	-----	---	-----------

10672	L/L	AL101	Quartuccio A	3.3	2.0	W	0600-0905
-------	-----	-------	--------------	-----	-----	---	-----------

New! Liberal Arts Associate's Degree Areas of Emphasis

Check out the updated Catalog online - www.gavilan.edu/catalog - click on Liberal Arts.

CRN Type Room Instructor Hrs. Units Days Begin-End

MUS 14B Instrumental Ensemble

Transferable: CSU; GAV-GE:C1

Instruction for the experienced musician with emphasis on the study and performance of a wide variety of musical styles from Renaissance to 20th century music for traditional ensembles, and extensive consideration of contemporary commercial and alternative repertoire, and performance techniques for popular ensembles.

10660	L/L	AL101	Juncker A Sotelo S	3.3	2.0	M	0130-0435
10673	L/L	AL101	Quartuccio A	3.3	2.0	W	0600-0905

MUS 14C Instrumental Ensemble

Transferable: CSU; GAV-GE:C1

Instruction for the experienced musician with emphasis on the study and performance of a wide variety of musical styles from Renaissance to 20th century music for traditional ensembles, and extensive consideration of contemporary commercial and alternative repertoire, and performance techniques for popular ensembles.

10662	L/L	AL101	Juncker A Sotelo S	3.3	2.0	M	0130-0435
10674	L/L	AL101	Quartuccio A	3.3	2.0	W	0600-0905

MUS 14D Instrumental Ensemble

Transferable: CSU; GAV-GE:C1

Instruction for the experienced musician with emphasis on the study and performance of a wide variety of musical styles from Renaissance to 20th century music for traditional ensembles, and extensive consideration of contemporary commercial and alternative repertoire, and performance techniques for popular ensembles.

10664	L/L	AL101	Juncker A Sotelo S	3.3	2.0	M	0130-0435
10675	L/L	AL101	Quartuccio A	3.3	2.0	W	0600-0905

MUS 16A Introduction to Audio Recording Techniques

Transferable: CSU

Survey of basic audio recording techniques and materials including acoustics, signal flow, block diagrams, cue systems, punch-ins, microphones and mic placement, frequency response, reverb, delay and outboard effects, stereo mixing, pre-mixing and actual recording. May be repeated once for credit.

10676	Lec	AL102	Sotelo S	3.3	3.0	W	1250-0355
-------	-----	-------	----------	-----	-----	---	-----------

CRN Type Room Instructor Hrs. Units Days Begin-End

MUS 21 Electronic Music/Sound Design

Transferable: CSU; GAV-GE:C1

Fundamentals of electronic music synthesis using computers. Midi sequencing, digital sound processing, sampling, digital multi-track recording utilizing the college's state of the art midi studio. May be repeated three times for credit. ADVISORY: Eligible for English 250, 260 and Mathematics 205.

10678	L/L	LI128	Sotelo S ARR	3.2	3.0	MW	0810-0930
			TBA	2.3			

MUS 22 Field Work and Service

Transferable: CSU

Supervised field work within the college and with local agencies. Students serve in useful group activities in leadership roles prescribed for them by faculty or community agencies. A maximum of six units may be completed. This is a pass/no pass course. REQUIRED: Learning contracts must be filled out and signed by the student and the supervising instructor.

10680	Fld Ex		Robb P	1.0			
			Above class meets off-campus:				
10681	Fld Ex	AL101	Quartuccio A	1.0			

MUS 23 Independent Study

Transferable: CSU

Designed to afford selected students specialized opportunities for exploring areas at the independent study level. The courses may involve extensive library work, research in the community, or special projects. May be repeated until six units of credit are accrued. This course has the option of a letter grade or pass/no pass. REQUIRED: The study outline prepared by the student and the instructor must be filed with the department and the dean.

10682	Ind	AL104	Juncker A	1.0			
10686	Ind	AL101	Montoya T	1.0			
10687	Ind	AL101	Robb P	1.0			
10688	Ind	AL101	Quartuccio A	1.0			
10684	Ind	AL101	Pruitt N	1.0			
10683	Ind	AL104	Juncker A	2.0			
10685	Ind	AL101	Pruitt N	2.0			
10689	Ind	AL105	Amirkhanian M	2.0			



Profile
ALUMNI

Master Sergeant Regulo Zapata Jr

Gavilan College alumnus Master Sergeant Regulo Zapata Jr, US Army (Retired) joined the Special Forces in 1974. Since then he has participated in numerous operations in several countries. Master Sergeant Regulo Zapata was a Special Forces Operations Sergeant with twenty-eight years of service with the US Army. Sergeant Zapata served as an enlisted soldier in the United States Army Special Operations Forces with the 2nd Battalion, 75th Rangers Airborne, 5th Special Forces Group, and 19th Special Forces Group while on active duty.

After graduating from Gavilan College, he graduated from the United States Army John F. Kennedy Special Warfare Center School, Army Special Forces Operations and Intelligence Course, United States Army Ranger School and many other Special Forces Courses available to a Green Beret, Army Special Forces enlisted soldier.

He is the author of the book Desperate Lands, which tells the story of his experiences in fighting the war on terror on the Horn of Africa, in Afghanistan and along the Pakistan border. "I have been asked many times why I decided to write a book called Desperate Lands. I would simply say that I wanted to share my extraordinary journey through ancient and desperate lands at the front lines of this on going war."

CRN Type Room Instructor Hrs. Units Days Begin-End

MUS 26 Symphony

Transferable: CSU, UC; GAV-GE:C1

Study and performance of orchestral literature. Individual and sectional skills development. Perform in public concerts each semester. May be repeated until a maximum of 8 units are accrued. ADVISORY: Demonstrated proficiency on individual's instrument and ability to read music.

10679	L/L	AL101	Quartuccio A	3.3	2.0	W	0600-0905
-------	-----	-------	--------------	-----	-----	---	-----------

MUS 98 Special Topics

Transferable: CSU; GAV-GE:C1

Special topics courses examine current problems or issues of interest to students within a specific discipline area. For topical content information, consult with appropriate department chairperson. For transfer status, check with a counselor. This course may have the option of a letter grade or pass/no pass.

10711	Lec	AL101	Quartuccio A	2.3	1.0	W	0700-0905
-------	-----	-------	--------------	-----	-----	---	-----------

Nursing: see Allied Health
Nutrition: see Biological Sciences
Performing Arts: see Theatre Arts (THEA)

PHILOSOPHY

PHIL 1 Introduction to Philosophy

Transferable: CSU, UC; CSU-GE:C2; IGETC:3B; GAV-GE:C2; CAN:PHIL2

Philosophy 1 is intended as a survey of the major areas and traditions of philosophy. The course examines central and significant questions about the meaning of life, who determines what is morally right or wrong, the ideal society, the various notions social justice, what is reality, and many other ideas. In pursuing these questions, students will be asked to read texts from writers around the world, both contemporary and ancient, discuss current events, and apply 'theory' to movies such as "The Matrix" trilogy, novels, and any other relevant application of the student's own choice. ADVISORY: Eligible for English 1A.

10722	Lec	HOL5	Johnston M	3.2	3.0	TR	0230-0350
-------	-----	------	------------	-----	-----	----	-----------

Above class meets at the Hollister Briggs site.

PHIL 2 Logic

Transferable: CSU, UC; CSU-GE:A3; GAV-GE:C2; CAN:PHIL6

Philosophy 2, Introduction to Logic, is intended as a survey of the primary approaches to argumentation and what has been traditionally called 'correct' reasoning. Learners will learn techniques of both deductive and inductive argumentation, how to spot a fallacy, as well as how to apply these techniques to other aspects of their lives outside the classroom. While logic is often quite formal, the goal is to see the practical application of this discipline. Additionally, learners will become acquainted with the cultural variations to reasoning in addition to the standard Western focal approach ADVISORY: Eligible for English 1A.

10715	Lec	AR103	Hodge E	3.2	3.0	MW	0810-0930
10716	Lec	AR103	Johnston M	3.3	3.0	T	0600-0905

PHIL 3A Ethics

Transferable: CSU, UC; CSU-GE:C2; IGETC:3B; GAV-GE:C2; CAN:PHIL4

Philosophy 3 is intended as a survey of the major areas and traditions of ethical and moral theories. The course examines central and significant questions about who determines what is morally right or wrong, the ideal society, the various notions social justice, moral agency and action in our lives and community, as well as many other topics. In pursuing these questions, students will be asked to read texts from writers around the world, both contemporary and ancient, discuss current events, and apply 'theory' to movies, novels, and any other relevant application of the student's own choice. ADVISORY: Eligible for English 1A.

10718	Lec	SS110	Hodge E	3.2	3.0	TR	0945-1105
-------	-----	-------	---------	-----	-----	----	-----------



MUS 16A

Introduction to Audio Recording Techniques

CRN # 10676
 Wednesday, 1250-0355
 Instructor: Sam Sotelo



Protools Recording Studio

Join the Concert Choir!

MUS 13

CRN 10671
 Tuesdays 6:00 - 9:05 pm
 with Phil Robb



3 units

PHIL 3A: INTRODUCTION TO ETHICS

Looking for a class that works with any major? Take Ethics!

Whether your major is Criminal Justice, Business, Social Science or Art, Ethics is a natural fit.



This course satisfies the Humanities requirement under the Gavilan College, the UC (IGETC) and CSU General Education patterns.

New! Liberal Arts Associate's Degree Areas of Emphasis

Check out the updated Catalog online - www.gavilan.edu/catalog - click on Liberal Arts.

CRN Type Room Instructor Hrs. Units Days Begin-End

PHIL 4 Critical Thinking and Writing

Transferable: CSU, UC; CSU-GE:A3, IGETC:1B; GAV-GE:C2

This course is designed to introduce the relationship between critical thinking and critical writing in a way that will be both enjoyable to the student and helpful in other aspects of life. The student will learn techniques of critical thinking, paying close attention to the current events, movies and popular media, music lyrics, as well as the textbook. Students will learn to identify deductive and inductive arguments and be able to evaluate their strength, create a strong argument of their own on a given topic, as well become experts in the area of critical analysis. The goal is to enable students to become strong, well informed, articulate members of the community as well as individuals with an empowered sense of self as an agent of change. PREREQUISITE: English 1A.

10719	Lec	AR103	Hodge E	3.2	3.0	MW	0945-1105
10720	Lec	SS110	Hodge E	3.2	3.0	TR	1250-0210
10714	Lec	MHG12	Grudzen G	3.2	3.0	MW	0230-0350

Above class meets at Morgan Hill Community site.

PHIL 6 Comparative Religions

Transferable: CSU, UC; CSU-GE:C2, IGETC:3B; GAV-GE:C2, F

Religion is a topic that ignites controversy -- most societies engage in religious practices, believe strongly in that tradition, and find a sense of identity within it. The controversy arises when differences are misunderstood, misrepresented, or placed in a hierarchy of assumed supremacy of one religion as superior to others. In this class, students explore the underlying commonality of various religious traditions, explore the uniqueness of the religions with which they are unfamiliar, and learn to see that diversity among beliefs doesn't have to create hostility. Students will explore religions from Indigenous Peoples throughout the world, East Asia (e.g. India), China, the Middle East, as well as some more recent trends in religion. ADVISORY: Eligible for English 1A.

10721	Lec	SS110	Hodge E	3.2	3.0	TR	1120-1240
-------	-----	-------	---------	-----	-----	----	-----------

PHIL 23 Independent Study

Transferable: CSU

Designed to afford selected students specialized opportunities for exploring areas at the independent study level. The courses may involve extensive library work, research in the community, or special projects. May be repeated until six units of credit are accrued. This course has the option of a letter grade or pass/no pass. REQUIRED: The study outline prepared by the student and the instructor must be filed with the department and the dean.

10717	Ind	SS106	Hodge E		1.0		
-------	-----	-------	---------	--	-----	--	--

Photography: see Art, CSIS or Digital Media

CRN Type Room Instructor Hrs. Units Days Begin-End

PHYSICAL EDUCATION: ACADEMIC

PE 1 Orientation for Student-Athlete Success

Transferable: CSU; CSU-GE:E

This course identifies and clarifies issues relevant to student-athletes. Students will learn practical skills which will assist them in obtaining their educational objectives, such as proper use of library services, time management and test and note taking information.

10250	Lec	CJ500	Del Carmen D	7.2	1.0	MTWR	1130-0100
-------	-----	-------	--------------	-----	-----	------	-----------

08/13/09 - 08/27/09

PE 3 Introduction to Athletic Training

Transferable: CSU, UC

An introductory course in athletic training/sports medicine. This course will familiarize the student with basic knowledge and basic skill level needed to become an athletic trainer. The course will cover anatomy/physiology, first aid, rehabilitation, injury recognition/evaluation/management, report writing/record keeping, facilities maintenance/supply ordering. Also included is hands-on participation at sporting events. ADVISORY: Allied Health 30 (may be concurrent) and eligible for English 260

10252	L/L	PB4A	Beymer H	3.2	4.0	TR	0945-1105
-------	-----	------	----------	-----	-----	----	-----------

PE 10A Fundamentals of Softball

Transferable: CSU, UC

Basic theory, strategy, technique, practice and conditioning of softball to prepare the individual student in all aspects of playing and coaching the sport. May be repeated once for credit. This course has the option of a letter grade or pass/no pass.

10255	L/L	GY131G	Dequin N	5.6	2.0	MTWR	0230-0340
-------	-----	--------	----------	-----	-----	------	-----------

PE 10B Fundamentals of Softball

Transferable: CSU, UC

This course offers review and advanced instruction in the theory, strategies, and techniques of softball for the purposes of preparing the individual student in all aspects of playing and coaching the sport. May be repeated once for credit. This course has the option of a letter grade or pass/no pass. ADVISORY: PE 10A

10256	L/L	GY131G	Dequin N	5.6	2.0	MTWR	0230-0340
-------	-----	--------	----------	-----	-----	------	-----------

PE 11A Fundamentals of Baseball

Transferable: CSU, UC

Theory, strategy, technique, practice and conditioning of baseball to prepare the individual student in all aspects of playing and coaching the sport. May be repeated once for credit. This course has the option of a letter grade or pass/no pass.

10259	L/L	GY131G	Andrade N	5.6	2.0	MTWR	0230-0340
-------	-----	--------	-----------	-----	-----	------	-----------



Profile
ALUMNI

John Tuttle

Gavilan College graduate John Tuttle transferred to San Francisco State University where he is pursuing a major in International Business and studying abroad in France.

"I enrolled myself in a beginner French course and also a Sailing class on top of the classes that I was already taking which are meeting my International Business major requirements at SFSU. I am taking Doing Business in Europe, International Marketing Strategy and International Business Law and it is so cool to be taking all of these courses in France! The Intercultural Communications and Small Group Communications classes have played a huge role as the courses here are set up for group work and that is a majority of your grade. In all the groups I am the only American...what an experience. Looking back on it Gavilan's teachers have been the best that I have been in a classroom with. I miss, and there will always be a place in my heart for, Gavilan!"

CRN Type Room Instructor Hrs. Units Days Begin-End

PE 11B Fundamentals of Baseball

Transferable: CSU, UC

This course offers review and advanced instruction in the theory, strategies, and techniques of baseball for the purpose of preparing the individual student in all aspects of playing and coaching the sport. May be repeated once for credit. This course has the option of a letter grade or pass/no pass. ADVISORY: Physical Education 11A.

10260 L/L GY131G Andrade N 5.6 2.0 MTWR 0230-0340

PE 12A Fundamentals of Football

Transferable: CSU, UC

Basic organization and administration of a football program involving equipment, practice schedules, personnel, conditioning, scouting, weight training, and football specific drills. May be repeated once for credit. This course has the option of a letter grade or pass/no pass.

10267 L/L APE120/121 Lango J 4.0 2.0 MTWR 0230-0325

PE 12B Fundamentals of Football

Transferable: CSU, UC

The administration and organization of a football program involving practice schedules, personnel, equipment, scouting, conditioning, weight training and football drills. May be repeated once for credit. This course has the option of a letter grade or pass/no pass. ADVISORY: Physical Education 12A.

10269 L/L APE120/121 Lango J 4.0 2.0 MTWR 0230-0325

PE 14A Fundamentals of Basketball

Transferable: CSU, UC; GAV-GE:E1

Basic theory, strategy, technique, practice, and conditioning involved in basketball to prepare the individual student in all aspects of playing and coaching the sport. May be repeated once for credit. This course has the option of a letter grade or pass/no pass.

10270 L/L APE120/121 Addison T 3.8 2.0 MW 0430-0615

PE 14B Fundamentals of Basketball

Transferable: CSU, UC; GAV-GE:E1

More in-depth and advanced instruction in the theory, strategy, practice, and conditioning in basketball to better prepare the individual student in all aspects of playing and coaching the sport. Designed for the student who has already completed PE 14A. May be repeated once for credit. This course has the option of a letter grade or pass/no pass. ADVISORY: PE 14A

10272 L/L APE120/121 Addison T 3.8 2.0 MW 0430-0615

PHYSICAL EDUCATION: ACTIVITIES

PE 16 Swimming

Transferable: CSU, UC; CSU-GE:E1; GAV-GE:E1

Coeducational activity designed for all skill levels. The course teaches the techniques of a variety of strokes and includes conditioning activities. Instruction is tailored to meet individual and group needs. May be repeated three times for credit. This course has the option of a letter grade or pass/no pass.

10273 Lab GY100P Dodd S 3.2 1.0 MW 1120-1240

PE 17 Golf

Transferable: CSU, UC; CSU-GE:E1; GAV-GE:E1

Coeducational activity designed for all skill levels. Fundamentals, techniques, rules and the etiquette of golf will be covered. May be repeated three times for credit. This course has the option of a letter grade or pass/no pass.

10274 Lab ERGOLF Krause S 3.0 .5 S 0900-1155
09/05/09 - 10/24/09 Class meets at Eagle Ridge Golf Club. Students will pay approximately \$20 in ball/equipment rental.

10275 Lab GY200C Andrade N 3.0 1.0 F 1040-0135
A facility use fee will be charged. Details at the first meeting.

PE Activities Classes can be taken for letter grade or pass/no pass.



Tutoring Center
www.gavilan.edu/tutor
408-848-4838
Located in LI 116



Free tutoring is available in a variety of subjects!

Work with a peer tutor and fellow students to develop a better understanding of course content.

Fall/Spring Semester:

Mon-Thurs: 8 am - 5 pm
Fri, 8 am - 4 pm

Evening tutoring hours will vary

Summer Session: Call for hours

Debbie King, Tutoring Program Coordinator

Social security numbers are no longer used as student identifiers. Find your new Gavilan Student ID number and choose a log-on PIN by going to www.gavilan.edu and clicking on the Self-Service Banner icon. You will use your new ID number and PIN to log into Self-Service Banner and register for summer and fall classes.

CRN Type Room Instructor Hrs. Units Days Begin-End

PE 18 Tennis

Transferable: CSU, UC; CSU-GE:E1; GAV-GE:E1

Coeducational activity stressing fundamentals of tennis such as forehand, backhand, serve and volley, along with the rules, etiquette and strategies of the game. May be repeated three times for credit. This course has the option of a letter grade or pass/no pass.

10276 Lab GY100C Kramer K 3.2 1.0 MW 1250-0210

PE 20 Bowling

Transferable: CSU, UC; CSU-GE:E1; GAV-GE:E1

Coeducational activity designed for beginning and intermediate bowlers; fundamentals and techniques of bowling. Scoring, bowling etiquette, terminology and team bowling are included. May be repeated three times for credit. This course has the option of a letter grade or pass/no pass.

10277 Lab GIBOWL Lango J 3.2 1.0 TR 0810-0930
Meets at Gilroy Bowl, 7554 Monterey Street, Gilroy. A facility use fee of \$1.50 per session is required.

PE 23 Independent Study

Transferable: CSU

Designed to afford selected students specialized opportunities for exploring areas at the independent study level. The courses may involve extensive library work, research in the community, or special projects. May be repeated until six units of credit are accrued. This course has the option of a letter grade or pass/no pass. REQUIRED: The study outline prepared by the student and the instructor must be filed with the department and the dean.

10444 ARR GY116 Dodd S 2.0

CRN Type Room Instructor Hrs. Units Days Begin-End

PE 24 Individualized Weight Training

Transferable: CSU, UC; CSU-GE:E1; GAV-GE:E1

An open laboratory for those who desire an individualized strength program using exercise machines and free weights. May be repeated three times for credit. This course has the option of a letter grade or pass/no pass.

10553 Lab GY123 Dodd S 1.0 day/time - see instructor
Students should check in the first week of the semester at the Fitness Center (GY 123) during lab hours (MWF: 7am - 2pm, TuTh: 8am - 2pm, M-Th evenings: 4:30 - 6:30 pm)

10554 Lab GY123 Dodd S .5 day/time - see instructor
Students should check in the first week of the semester at the Fitness Center (GY 123) during lab hours (MWF: 7am - 2pm, TuTh: 8am - 2pm, M-Th evenings: 4:30 - 6:30 pm).

PE 39 Fencing

Transferable: CSU, UC; CSU-GE:E1; GAV-GE:E1

This course will explore the offensive and defensive fencing skills with a foil. May be repeated three times credit. This course has the option of a letter grade or pass/no pass.

10451 Lab APE101 DeCesare J 3.3 1.0 M 0600-0905
Equipment will be provided. A \$6.00 user fee will be charged, payable to the instructor.

PE 44 Aerobics

Transferable: CSU, UC; CSU-GE:E1; GAV-GE:E1

A program of aerobic fitness. Includes various forms of exercise to improve health, heart, and body composition. May be repeated three times for credit. This course has the option of a letter grade or pass/no pass.

10454 Lab GY131G Dequin N 3.2 1.0 MW 1120-1240

PE 61 Swim for Fitness

Transferable: CSU, UC; CSU-GE:E1; GAV-GE:E1

Designed to develop endurance and swimming skills in order to maintain good cardiovascular/physical fitness. Intermediate swimming ability recommended. May be repeated three times for credit. This course has the option of a letter grade or pass/no pass.

10456 Lab GY100P Dodd S 3.2 .5 TR 0515-0635
09/03/09 - 10/22/09

PE 62 Yoga

Transferable: CSU, UC; CSU-GE:E1; GAV-GE:E1

Coeducational activity designed for beginning and intermediate yoga students. A program designed to improve flexibility and reduce stress by learning a series of poses and focusing on proper breathing techniques. May be repeated three times for credit. This course has the option of a letter grade or pass/no pass.

10447 Lab APE101 STAFFS 3.2 1.0 MW 1250-0210

10445 Lab MHG10/11 Watson M 3.2 1.0 MW 0500-0620
Above class meets at Morgan Hill Community Site.

10450 Lab PORTHL Muscari D 3.2 1.0 TR 0630-0750
Class Location: Portuguese Hall, 695 Seventh Street, Hollister, CA.

PE 64 Individualized Cardiovascular Fitness

Transferable: CSU, UC; CSU-GE:E1; GAV-GE:E1

A fitness program which develops cardiovascular endurance through an individualized open lab format. May be repeated three times for credit. This course has the option of a letter grade or pass/no pass.

10555 Lab GY123 Dodd S 1.0 day/time - see instructor
Students should check in the first week of the semester at the Fitness Center (GY 123) during lab hours (MWF: 7am - 2pm, TuTh: 8am - 2pm, M-Th evenings: 4:30 - 6:30pm).

10556 Lab GY123 Dodd S .5 day/time - see instructor
Students should check in the first week of the semester in the Fitness Center (GY123) during lab hours (MWF: 7am - 2pm, TuTh: 8am - 2pm, M-Th evenings: 4:30 - 6:30 pm).

CRN Type Room Instructor Hrs. Units Days Begin-End

PE 66 Dance Fundamentals

Transferable: CSU, UC; CSU-GE:E1; GAV-GE:E1

Designed to introduce and develop movement principles and skills necessary to perform modern dance and ballet. May also include jazz and/or tap dance. Emphasizes enjoyment of dance as a form of exercise and will include some conditioning. Basic choreography skills will be included. May be repeated three times for credit. This course has the option of a letter grade or pass/no pass.

10563 Lab APE101 Waggoner K 3.4 1.0 TR 1120-1245

PE 70 Pilates

Transferable: CSU, UC; CSU-GE:E1; GAV-GE:E1

This class utilizes the Pilates exercise system focused on improving flexibility and strength for the total body through a series of controlled movements. May be repeated three times for credit. This course has the option of a letter grade or pass/no pass.

10564 Lab APE101 Muscari D 3.2 1.0 TR 1250-0210

10565 Lab PORTHL Muscari D 3.2 1.0 TR 0500-0620
Class location: Portuguese Hall, 695 Seventh Street, Hollister, CA.

PE 74 Hiking

Transferable: CSU, UC; CSU-GE:E1; GAV-GE:E1

Introduces the Santa Clara county parks, trails, and surrounding areas. Includes fun, challenging hikes which average 5-8 miles on moderate to steep terrain. May be repeated three times for credit. This course has the option of a letter grade or pass/no pass.

10568 Lab GY131G Dequin N 3.0 1.0 F 0810-1100

PE 75 Sports Conditioning

Transferable: CSU, UC; CSU-GE:E1; GAV-GE:E1

This activity class is designed to improve the physical condition of male and female athletes. It includes strength training, cardiovascular endurance, plyometric training, and sport specific techniques. May be repeated three times for credit. This course has the option of a letter grade or pass/no pass.

10558 Lab GY123 Dodd S 1.0
Students should check in the first week of the semester at the Fitness Center (GY 123) during lab hours (MWF: 7am - 2pm, TuTh: 8am - 2pm, M-Th evenings: 4:30 - 6:30 pm).

10561 Lab GY123 Dodd S .5
Students should check in the first week of the semester at the Fitness Center (GY 123) during lab hours (MWF: 7am - 2pm, TuTh: 8am - 2pm, M-Th evenings: 4:30 - 6:30 pm).

NEW PE 78 Dance Repertory

Transferable: CSU

Study, rehearse and perform choreography provided by faculty, guest artists and/or student choreographers. Opportunities to perform at informal settings at the college and various locations in the Gavilan community. The class includes dance warm up and work on technical skills, improvisational study, creating choreographic studies for group and solo forms and rehearsal and performance of finished dances either for the class, college or community. May be repeated three times for credit. This course has the option of a letter grade or pass/no pass. Also listed as THEA 78. ADVISORY: An ability to perform more complex patterns of movement with a strong level of dance technique: or Current enrollment in a dance class: or Permission of the instructor.

10991 Lab TH125 Lawton-Haehl J 3.3 1.0 S 1000-0105

PHYSICAL EDUCATION: ADAPTED

PE 34 Adapted Aquatic Exercise

Transferable: CSU, UC; CSU-GE:E1; GAV-GE:E1

This course is designed to help individuals who by the nature of their disability such as wheelchair use, back injury, cardiovascular impairment, multiple sclerosis or other disabling condition require a specific aquatic exercise program that will contribute to their physical well-being. May be repeated as necessary based on measurable progress as documented in the student's educational contract. This course has the option of a letter grade or pass/no pass.

10622 Lab GY100P Ellis D 3.2 1.0 MW 0810-0930

10624 Lab GY100P Ellis D 3.2 1.0 TR 1120-1240
Sato K

10627 Lab GY100P Ellis D 3.2 1.0 MW 1250-0210

Classroom Locations: Refer to "How to Use This Schedule" on page 5.



Appropriate footwear is required in all gym facilities. No barefeet permitted.

CRN Type Room Instructor Hrs. Units Days Begin-End

PE 35 Adapted Swimming for Total Fitness

Transferable: CSU, UC; CSU-GE:E1; GAV-GE:E1

An individualized program of activities designed for students with physical disabilities to improve flexibility and range-of-motion, increase joint movement, improve circulation, and improve control of body movement through water adjustment and activities. Develops an appreciation of physical activity as a regular planned contribution to one's overall well-being. May be repeated as necessary based on measurable progress as documented in the student's educational contract. This course has the option of a letter grade or pass/no pass.

10629	Lab	GY100P	Ellis D	3.2	1.0	MW	0810-0930
10630	Lab	GY100P	Ellis D Sato K	3.2	1.0	TR	1120-1240
10631	Lab	GY100P	Ellis D	3.2	1.0	MW	1250-0210

PE 36 Adapted Physical Education

Transferable: CSU, UC; CSU-GE:E1; GAV-GE:E1

An individualized program of adaptive physical education activities designed to meet the needs of students with physical disabilities. Develops an appreciation of physical activity as a regular planned contribution to one's overall well-being. May be repeated as necessary based on measurable progress as documented in the student's educational contract. This course has the option of a letter grade or pass/no pass.

10636	Lab	APE101/108	Ellis D	3.2	1.0	MW	0945-1105
10637	Lab	APE101/108	Ellis D	3.2	1.0	TR	0945-1105
10638	Lab	APE101/108	Ellis D	3.2	1.0	MW	1120-1240
10639	Lab	APE101/108	Ellis D	3.2	1.0	TR	1250-0210

PE 38 Adapted Cardiovascular Conditioning & Training

Transferable: CSU, UC; CSU-GE:E1; GAV-GE:E1

An individualized program of adapted exercises in weight training, stretching and cardiovascular conditioning for those individuals that have been disabled through stroke, cardiovascular accident, arthritis, multiple sclerosis, or other condition. May be repeated as necessary based on measurable progress as documented in the student's educational contract. This course has the option of a letter grade or pass/no pass.

10641	Lab	APE101/108	Ellis D	3.2	1.0	MW	0945-1105
10645	Lab	APE101/108	Ellis D	3.2	1.0	TR	0945-1105
10646	Lab	APE101/108	Ellis D	3.2	1.0	MW	1120-1240
10648	Lab	APE101/108	Ellis D	3.2	1.0	TR	1250-0210

PE 534 Adapted Aquatic Exercise

Transferable: No

Designed to help individuals who by the nature of their disability such as wheelchair use, back injury, cardiovascular impairment, multiple sclerosis or other disabling condition require a specific aquatic exercise program that will contribute to their physical well being. May be repeated as necessary based on measurable progress as documented in the student's educational contract. This is a pass/no pass course.

10649	Lab	GY100P	Ellis D	3.2	1.0	MW	0810-0930
10650	Lab	GY100P	Ellis D Sato K	3.2	1.0	TR	1120-1240
10651	Lab	GY100P	Ellis D	3.2	1.0	MW	1250-0210

PE 535 Adapted Swimming for Total Fitness

Transferable: No

An individualized program of activities designed for students with physical disabilities to improve flexibility and range-of-motion, increase joint movement, improve circulation, and improve control of body movement through water adjustment and activities. Develops an appreciation of physical activity as a regular planned contribution to one's overall well-being. May be repeated as necessary based on measurable progress as documented in the student's educational contract. This course is pass/no pass.

10652	Lab	GY100P	Ellis D	3.2	1.0	MW	0810-0930
10654	Lab	GY100P	Ellis D Sato K	3.2	1.0	TR	1120-1240
10653	Lab	GY100P	Ellis D	3.2	1.0	MW	1250-0210



GO RAMS!

Fall Sports



Football

Men's Basketball

Men's Soccer

Women's Volleyball

Students wishing to participate in the intercollegiate athletic programs must be enrolled in and attending a minimum of 12 units during the first season of competition with a minimum of nine units applying towards a degree program.

For more information, contact the Athletic Department at 848-4876.

Also check out the following Activity Classes...

- Aerobics
- Bowling
- Cardio Fitness
- Dance
- Fencing
- Golf
- Pilates
- Soccer
- Swimming
- Tennis
- Volleyball
- Weight Training
- Yoga

PE 24 Individualized Weight Training
PE 64 Cardiovascular Fitness

Open Lab Class Format

Designed for individualized strength or cardiovascular fitness programs in an open lab setting using a variety of exercise equipment.

Section hours by arrangement

- ★ 1.7 to 3.4 weekly hours
- ★ .5 or 1.0 unit
- ★ Fitness Center (GYM 123)



Fitness Center Lab Hours

Day	MWF	7:00 am - 2:00 pm
	TuTh	8:00 am - 2:00 pm
Eve.	MTuWTh	4:30 pm - 6:30 pm

Students should check in the first week of the semester during lab hours.

Intercollegiate **SOCCER** 
Help build the team.
All are welcome!



CRN Type Room Instructor Hrs. Units Days Begin-End

PE 536 Adapted Physical Education

Transferable: No

An individualized program of adaptive physical education activities designed to meet the needs of students with physical disabilities. Develops an appreciation of physical activity as a regular planned contribution to one's overall well-being. May be repeated as necessary based on measurable progress as documented in the student's educational contract. This is a pass/no pass course.

10655	Lab	LOADCS1	Sato K	3.2	1.0	MW	0945-1105
Class meets at Live Oak Adult Day Services, 651 West Sixth St., Gilroy							
10656	Lab	APE101/108	Ellis D	3.2	1.0	MW	0945-1105
10657	Lab	APE101/108	Ellis D	3.2	1.0	TR	0945-1105
10663	Lab	APE101/108	Ellis D	3.3	1.0	F	0945-1250
Specialized class for students with developmental disabilities.							
10658	Lab	LOADCS1	Maringer J	3.3	1.0	F	0945-1250
Class meets at Live Oak Adult Day Services, 651 West Sixth St., Gilroy							
10659	Lab	APE101/108	Ellis D	3.2	1.0	MW	1120-1240
10661	Lab	APE108	Ellis D	3.2	1.0	TR	1250-0210

PE 538 Adapted Cardiovascular Conditioning & Training

Transferable: No

An individualized program of adapted exercises in weight training, stretching and cardiovascular conditioning for those individuals that have been disabled through stroke, cardiovascular accident, arthritis, multiple sclerosis, or other condition. May be repeated as necessary based on measurable progress as documented in the student's educational contract. This is a pass/no pass course.

10665	Lab	APE101/108	Ellis D	3.2	1.0	MW	0945-1105
10666	Lab	APE101/108	Ellis D	3.2	1.0	TR	0945-1105
10667	Lab	LOADCS1	Maringer J	3.2	1.0	TR	0945-1105
Class meets at Live Oak Adult Day Services, 651 West Sixth St., Gilroy							
10669	Lab	APE101/108	Ellis D	3.2	1.0	MW	1120-1240
10670	Lab	APE108	Ellis D	3.2	1.0	TR	1250-0210

INTERCOLLEGIATE ATHLETICS

ATH 35 Basketball

Transferable: CSU, UC; CSU-GE:E1; GAV-GE:E1

This course provides practice and competition in intercollegiate basketball. May be repeated three times for credit. This course has the option of a letter grade or pass/no pass.

10245	Lab	GY131G	Addison T	10.0	2.0	MTWRF	0230-0430
-------	-----	--------	-----------	------	-----	-------	-----------

ATH 42 Football

Transferable: CSU, UC; CSU-GE:E1; GAV-GE:E1

This course provides practice and competition in intercollegiate football. May be repeated three times for credit. This course has the option of a letter grade or pass/no pass.

10246	Lab	GY131G	Lango J	10.0	2.0	MTWRF	0330-0530
-------	-----	--------	---------	------	-----	-------	-----------

Students should be aware that there are inherent risks involved in any physical exercise. Students are strongly advised to consult a physician prior to participating in any physical education activity.

Check out

- Classes and services offered at the satellite sites...
 - Hollister classes - page 60.
 - Morgan Hill classes - page 62.
- Late-Start Classes... page 57
- Online/Hybrid Classes... page 58-59

CRN Type Room Instructor Hrs. Units Days Begin-End

ATH 46 Volleyball

Transferable: CSU, UC; CSU-GE:E1; GAV-GE:E1

This course provides practice and competition in intercollegiate volleyball for women. May be repeated three times for credit. This course has the option of a letter grade or pass/no pass.

10247	Lab	GY131G	Kramer K	10.0	2.0	MTWRF	0430-0630
-------	-----	--------	----------	------	-----	-------	-----------

ATH 47 Soccer

Transferable: CSU, UC; CSU-GE:E1; GAV-GE:E1

This course provides practice and competition in intercollegiate soccer. May be repeated three times for credit. This course has the option of a letter grade or pass/no pass.

10249	Lab	GY131G	Marques A	10.0	2.0	MTWRF	0230-0430
-------	-----	--------	-----------	------	-----	-------	-----------

PHYSICAL SCIENCE

PSCI 1 Principles of Physical Science

Transferable: CSU, UC; CSU-GE:B1, IGETC:5A; GAV-GE:B1

An introduction to the physical sciences for the non-science major. Attention is focused on fundamental laws of nature, their development and relation to the physical world. ADVISORY: Mathematics 205 and eligible for English 250 and 260.

10442	Lec	CH105	Staff	3.3	3.0	T	0600-0905
-------	-----	-------	-------	-----	-----	---	-----------

PSCI 2 Introduction to Meteorology

Transferable: CSU, UC; CSU-GE:B1, IGETC:5A; GAV-GE:B1

An introductory course in Meteorology that is both descriptive and analytical on the physical principles affecting the earth's weather. Topics covered include the nature of the atmosphere, solar energy, heat, temperature, pressure, stability, moisture, wind, storms, severe weather and forecasting. The course introduces climatology as a scientific study and will look at the earth's climatic history, current research in climate modeling and the possibility of global climate change. ADVISORY: MATH 205.

10443	ONLINE	Vantuyl A		3.0			
-------	--------	-----------	--	-----	--	--	--

You must have an email account to take this course. Start your course by going to www.gavilan.edu/disted. Unless you have made prior arrangements with the instructor, you MUST log on by 11:59 pm on the first day of the semester. Late adds must login within 24 hours of adding this course. If you miss the deadline you may be dropped. For help, contact your instructor or email disted@gavilan.edu.

PHYSICS

PHYS 1 Introduction to Physics

Transferable: CSU, UC; CSU-GE:B1, B3, IGETC:5A; GAV-GE:B1, B3

This course is an introduction to the fundamental physical principles that control the world around us. Students will explore the fundamental principles of physics, their historical development, their application to everyday phenomena, and their impact upon political, social, and environmental issues. Laboratory exercises will explore the everyday world. ADVISORY: Mathematics 205.

10440	L/L	CH102	Bass J	6.6	4.0	TR	0945-1250
-------	-----	-------	--------	-----	-----	----	-----------

PHYS 2A General Physics

Transferable: CSU, UC; CSU-GE:B1, B3, IGETC:5A; GAV-GE:B1, B3; CAN:PHYS2, PHYS SEQ A

An introduction to the principles of physics using algebra and trigonometry. Topics include kinematics in one and two dimensions, vectors, equilibrium and non-equilibrium applications of Newton's Laws, work and energy, momentum, rotational kinematics and dynamics, simple harmonic motion, elasticity, thermal physics, thermodynamics, and waves. PREREQUISITE: MATH 8A or MATH 9. ADVISORY: Eligible for English 250 and English 260.

10441	L/L	CH102	Lee R	3.2	4.0	MW	1120-1240
	L/L	CH102	Lee R	2.3		W	0230-0435
	L/L	CH102	Lee R	1.0		F	1140-1230

Physiology: see Biological Sciences

CRN Type Room Instructor Hrs. Units Days Begin-End

POLITICAL SCIENCE

POLS 1 Introduction to American Government

Transferable: CSU, UC; CSU-GE:D8, IGETC:4H, 7A; GAV-GE:D1, D2; CAN:GOVT2
 Explores the development of American political institutions and their utilization in dealing with issues arising at the international, national and state levels. Emphasis is placed on those problems which have defined our federal system of government. California government and appropriate state institutions will be included as a vital part of our federal system of government. **ADVISORY:** Eligible for English 250 and English 260.

10033	Lec	SS210	Turetzky M	3.2	3.0	MW	0810-0930
10035	Lec	SS210	Turetzky M	3.2	3.0	TR	0810-0930
10354	Lec	HOL5	STAFF S	3.2	3.0	MW	0945-1105
Above class meets at the Hollister Briggs site.							
10034	Lec	LI171	Turetzky M	3.2	3.0	MW	0230-0350
This service learning section involves community work. See page 64 for details.							
10036	Lec	SS210	Tewes J	3.3	3.0	M	0600-0905

10031 ONLINE Turetzky M 3.0
 You must have an email account to take this course. Start your course by going to www.gavilan.edu/disted. Unless you have made prior arrangements with the instructor, you **MUST** log on by 11:59 pm on the first day of the semester. Late adds must login within 24 hours of adding this course. If you miss the deadline you may be dropped. For help, contact your instructor or email disted@gavilan.edu.

10032 ONLINE Turetzky M 3.0
 You must have an email account to take this course. Start your course by going to www.gavilan.edu/disted. Unless you have made prior arrangements with the instructor, you **MUST** log on by 11:59 pm on the first day of the semester. Late adds must login within 24 hours of adding this course. If you miss the deadline you may be dropped. For help, contact your instructor or email disted@gavilan.edu.

POLS 3 Introduction to Comparative Politics

Transferable: CSU, UC; CSU-GE:D8, IGETC:4H; GAV-GE:D2, F
 Comparative survey of political institutions and processes around the globe. Selected nations may include, but are not restricted to: the United Kingdom, France, Germany, Japan, Russia, India, Nigeria, and Mexico. **ADVISORY:** Eligible for English 250 and English 260.

10040 ONLINE Turetzky M 3.0
 You must have an email account to take this course. Start your course by going to www.gavilan.edu/disted. Unless you have made prior arrangements with the instructor, you **MUST** log on by 11:59 pm on the first day of the semester. Late adds must login within 24 hours of adding this course. If you miss the deadline you may be dropped. For help, contact your instructor or email disted@gavilan.edu.

POLS 4 Introduction to International Relations

Transferable: CSU, UC; CSU-GE:D8, IGETC:4H; GAV-GE:D2, F
 This course provides an introduction to key contemporary international problems and the means to analyze them. Major parts of the course cover such topics as war and peace, foreign policymaking, the international economy, and future trends in world politics.

10041	Lec	LI171	Turetzky M	3.2	3.0	MW	1250-0210
-------	-----	-------	------------	-----	-----	----	-----------

POLS 6 Introduction to Conflict Resolution

Transferable: CSU; CSU-GE:D7; GAV-GE:D2
 Introduction to Conflict Resolution introduces students to conflict resolution and mediation. Integrating theory and practice, students will assess core concepts about the causes and resolution of conflict, and will practice communication skills for conflict resolution. Students will examine how ethnicity, gender, and class affect power in conflict situations. They will be able to formulate appropriate conflict resolution strategies, and will develop and practice various basic co-mediation skills. This course has the option of a letter grade or pass/no pass. This course is also listed as AJ 6 and PSYC 6 and CMUN 6. **ADVISORY:** English 250 and English 260.

10026	Lec	SS205	Halper L	3.2	3.0	TR	1250-0210
This service learning section involves community work. See page 64 for details.							



- ◆ Are you a math based major? (BIO, CSIS Architecture, etc.)
- ◆ Do you want to transfer to a 4-year university?
- ◆ Do you have financial need? **You may be eligible.**

Gavilan's MESA Program is now accepting applications. MESA students are entitled to work-shops, academic advising, campus visits, facilitator and instructor led study groups and more! For more information call 408-848-4887 or visit the MESA Study Center in PH115.

◆ www.gavilan.edu/MESA ◆

**MATH • ENGINEERING • SCIENCE MAJORS
 PLANNING TO TRANSFER?**

Admission for these majors is very competitive

- ◆ High-unit majors do not need to fulfill all general education requirements
- ◆ You do not need to get an AA or AS degree to transfer
- ◆ You should plan your sequential courses early.
- ◆ You may be qualified to sign a Transfer Admissions agreement with UC or CSU.

MESA has been recognized by the White House, the Ford Foundation and Harvard University for its innovation and mentoring success in engineering, science and mathematics. Excelencia in Education recently named MESA as a semifinalist winner in its 2008 Examples of Excelencia which identified MESA as a national community college model in its ability to strengthen Latino student success.

CRN Type Room Instructor Hrs. Units Days Begin-End

POLS 27 Contemporary Leadership

Transferable: CSU; GAV-GE:E2
 A cross-disciplinary approach to the theory and practice of leadership. Includes effective communication styles including issues related to gender and culture. Class includes topics on ethics, power, and how to run effective meetings including the use of parliamentary procedure. Skills directly applicable to work, personal and college environments. May be repeated for a maximum of 10 units. Also listed as PSYC 27. **ADVISORY:** Eligible for English 250 and English 260.

10959	L/L	SC154N/S	Staff	3.2	3.0	TR	0945-1105
	ARR		TBA	1.7			

PSYCHOLOGY

PSYC 1A Introduction to Psychology

Transferable: CSU, UC; CSU-GE:D9, IGETC:4I; GAV-GE:D2; CAN:PSY2
 The nature, scope, methods, presuppositions, history, and fields of psychology together with the scientific study of factors influencing human behavior, human development, perception, learning, memory, emotion, personality, frustration, and psychotherapy. **ADVISORY:** Eligible for English 250 and English 260.

10042	Lec	SS214	Oler C	3.2	3.0	MW	0810-0930
10043	Lec	SS214	Hinn G	3.2	3.0	TR	0810-0930
10044	Lec	HOL2	Oler C	3.2	3.0	MW	1120-1240
Above class meets at the Hollister Briggs site.							
10045	Lec	SS210	Campilli J	3.2	3.0	TR	1250-0210
10046	Lec	SS214	Oler C	3.2	3.0	TR	0230-0350
10047	Lec	HOL2	Oler C	3.3	3.0	R	0600-0905
Above class meets at the Hollister Briggs site.							

PSYC 1B Introduction to Psychology

Transferable: CSU, UC; CSU-GE:D9, IGETC:4I; GAV-GE:D2
 Continuation of Psychology 1A. This course stresses the biological basis of behavior including: neuroanatomy, the senses, perception, learning, thinking, and psychological disorders. **PREREQUISITE:** Completion of Psychology 1A with a grade of 'C' or better.

10048	Lec	SS210	Oler C	3.2	3.0	TR	1120-1240
-------	-----	-------	--------	-----	-----	----	-----------

Don't go to the wrong city

MHG = Morgan Hill Community Center site
 HOL = Hollister Briggs Building site

CRN Type Room Instructor Hrs. Units Days Begin-End

PSYC 2 Early Child Development

Transferable: CSU, UC; CSU-GE:D9, E, IGETC:4; GAV-GE:D2

A systematic study of the child from prenatal life through the preschool years. The course integrates the basic concepts of physical, cognitive and psychosocial development at each major stage of life during this period. This course is also listed as CD 2. This course has the option of a letter grade or pass/no pass. ADVISORY: Eligible for English 250 and English 260.

10600 Lec MHG4 Bumgarner M 3.2 3.0 MW 0945-1105
Above class meets at Morgan Hill Community site.

10965 Lec GHS-B1 Weiler J 3.3 3.0 T 0330-0630
This class is part of the High Step Program. It will be offered at Gilroy High School, room B-1. This class is open to all students. For more information, see a Gavilan counselor.

10602 Lec HOL5 Muscari D 3.3 3.0 M 0600-0905
Above class meets at the Hollister Briggs site.

10609 ONLINE Bumgarner M 3.0
You must have an email account to take this course. Start your course by going to www.gavilan.edu/disted. Unless you have made prior arrangements with the instructor, you MUST log on by 11:59 pm on the first day of the semester. Late adds must login within 24 hours of adding this course. If you miss the deadline you may be dropped. For help, contact your instructor or email disted@gavilan.edu.

PSYC 3 Child Growth and Development During the School Years

Transferable: CSU, UC; CSU-GE:D9, E, IGETC:4; GAV-GE:D2

Continuation of the study of child development with emphasis on children from six years of age through adolescence. Includes developmental theories and topics relevant to these ages. This course is also listed as CD 3. This course has the option of a letter grade or pass/no pass. ADVISORY: Eligible for English 250 and English 260; Psychology 2.

10453 Lec MHG4 Bumgarner M 3.2 3.0 MW 1120-1240
Above class meets at Morgan Hill Community site.

10967 Lec GHS-B6 O'Leary M 3.0 3.0 T 0330-0630
This class is part of the High Step Program. It will be offered at Gilroy High School, room B-6. This class is open to all students. For more information, see a Gavilan counselor.

10466 ONLINE Bumgarner M 3.0
You must have an email account to take this course. Start your course by going to www.gavilan.edu/disted. Unless you have made prior arrangements with the instructor, you MUST log on by 11:59 pm on the first day of the semester. Late adds must login within 24 hours of adding this course. If you miss the deadline you may be dropped. For help, contact your instructor or email disted@gavilan.edu.

PSYC 5 Self-Assessment and Career Development

Transferable: CSU; CSU-GE:E2; GAV-GE:E2

A course designed to assist the student in learning more about personal values, personality, interests, exploration of career choice, and occupational opportunities through the use of various personal assessment instruments. The delivery options for this course include online and self-paced formats. This course is also listed as GUID 1. ADVISORY: Eligible for English 250 and English 260. \$12 fee will be charged for career assessment materials.

10841 Lec CH105 Arteaga B 13.6 3.0 MTWR 0830-1140
07/27/09 - 08/20/09

10831 Lec CJ500 Godley J 3.2 3.0 TR 0105-0225

10828 Lec HOL2 Lopez A 3.2 3.0 MW 0230-0350
Above class meets at the Hollister Briggs site.

10830 Lec SBHS-194 Caffiero J 3.2 3.0 MW 0400-0520
This class is part of the High Step Program. It will be offered at San Benito High School, room 194. This class is open to all students. For more information, see a Gavilan counselor.

10832 ONLINE Sharboneau R 3.0
You must have an email account to take this course. Start your course by going to www.gavilan.edu/disted. Unless you have made prior arrangements with the instructor, you MUST log on by 11:59 pm on the first day of the semester. Late adds must login within 24 hours of adding this course. If you miss the deadline you may be dropped. For help, contact your instructor or email disted@gavilan.edu.

10829 ONLINE Tenney L 3.0
You must have an email account to take this course. Start your course by going to www.gavilan.edu/disted. Unless you have made prior arrangements with the instructor, you MUST log on by 11:59 pm on the first day of the semester. Late adds must login within 24 hours of adding this course. If you miss the deadline you may be dropped. For help, contact your instructor or email disted@gavilan.edu.

CRN Type Room Instructor Hrs. Units Days Begin-End

PSYC 6 Introduction to Conflict Resolution

Transferable: CSU; CSU-GE:D7; GAV-GE:D2

Introduction to Conflict Resolution introduces students to conflict resolution and mediation. Integrating theory and practice, students will assess core concepts about the causes and resolution of conflict, and will practice communication skills for conflict resolution. Students will examine how ethnicity, gender, and class affect power in conflict situations. They will be able to formulate appropriate conflict resolution strategies, and will develop and practice various basic co-mediation skills. This course has the option of a letter grade or pass/no pass. This course is also listed as AJ 6 and POLS 6 and CMUN 6. ADVISORY: English 250 and English 260.

10027 Lec SS205 Halper L 3.2 3.0 TR 1250-0210
This service learning section involves community work. See page 64 for details.

PSYC 7 Cultural Context of Child & Family in a Diverse Society

Transferable: CSU; CSU-GE:D7; GAV-GE:D2, F

Examines cultural influences on child-rearing practices, family values, and human development. Perspectives from social sciences are used to critique and review theoretical and practical implications of oppression and privilege as they apply to families, schools, and communities, including historical and socio-cultural factors. The processes of socialization and identity development, and the importance of respectful, reciprocal relationships that support and empower families. Self-examination and reflection on issues related to social identity, stereotypes and bias, social and educational access, media and schooling. Also listed as CD 7 and ANTH 9. ADVISORY: Eligible for English 250 and English 260.

10868 ONLINE Bumgarner M 3.0

You must have an email account to take this course. Start your course by going to www.gavilan.edu/disted. Unless you have made prior arrangements with the instructor, you MUST log on by 11:59 pm on the first day of the semester. Late adds must login within 24 hours of adding this course. If you miss the deadline you may be dropped. For help, contact your instructor or email disted@gavilan.edu.

PSYC 22 Field Work and Service

Transferable: CSU

Supervised field work within the college and with local agencies. Students serve in useful group activities in leadership roles prescribed for them by faculty or community agencies. A maximum of six units may be completed. This is a pass/no pass course. REQUIRED: Learning contracts must be filled out and signed by the student and the supervising instructor.

10860 Fld Ex SS202A Oler C 1.0

PSYC 23 Independent Study

Transferable: CSU

Designed to afford selected students specialized opportunities for exploring areas at the independent study level. The courses may involve extensive library work, research in the community, or special projects. May be repeated until six units of credit are accrued. This course has the option of a letter grade or pass/no pass. REQUIRED: The study outline prepared by the student and the instructor must be filed with the department and the dean.

10861 Ind Hinn G 2.0

PSYC 27 Contemporary Leadership

Transferable: CSU; GAV-GE:E2

A cross-disciplinary approach to the theory and practice of leadership. Includes effective communication styles including issues related to gender and culture. Class includes topics on ethics, power, and how to run effective meetings including the use of parliamentary procedure. Skills directly applicable to work, personal and college environments. May be repeated for a maximum of 10 units. Also listed as POLS 27. ADVISORY: Eligible for English 250 and English 260.

10960 L/L SC154N/S Staff 3.2 3.0 TR 0945-1105
ARR TBA 1.7

PSYC 30 Psychology of Interpersonal Communication

Transferable: CSU

This course introduces the student to theory, skills and psychological dynamics of communication used in interpersonal relationships. Course content covers a study of verbal and nonverbal communication, listening skills and barriers, conflict resolution, message clarification and the recognition of destructive communication patterns. ADVISORY: Eligible for English 250 and English 260.

10049 Lec SS214 Hinn G 3.3 2.0 T 0600-0905

CRN Type Room Instructor Hrs. Units Days Begin-End

Public Speaking: see Communication Studies

REAL ESTATE

RE 162 Real Estate Practice

Transferable: CSU

Introduction to the practice of real estate in California; emphasis on the practical application of listings, selling, advertising, financing, escrow, taxation, and valuation of real estate. This course meets a requirement for the California Broker's License. This course has the option of a letter grade or pass/no pass. May be repeated three times for credit. ADVISORY: Real Estate 160

10950	Lec	PB13	Frimann G	6.6	3.0	TR	0630-0935
09/01/09 - 10/20/09							

RE 165 Legal Aspects of Real Estate

Transferable: CSU

A study of California real estate law, including rights incident to property ownership and management, agency contracts, transfer of interest, liens and their foreclosure, encumbrances, and recent legislation relating to the foregoing. This course meets a requirement for the California Broker's License. This course has the option of a letter grade or pass/no pass. ADVISORY: Real Estate 160

10952	ONLINE	Banks S		3.0			
-------	--------	---------	--	-----	--	--	--

You must have an email account to take this course. Start your course by going to www.gavilan.edu/disted. Unless you have made prior arrangements with the instructor, you MUST log on by 11:59 pm on the first day of the semester. Late adds must login within 24 hours of adding this course. If you miss the deadline you may be dropped. For help, contact your instructor or email disted@gavilan.edu.

RE 167 Real Estate Economics

Transferable: CSU

An introduction to the causes and effects of value fluctuations in real estate, the nature of land economics and development of residential, commercial, industrial, recreational and special purpose properties. The student will study the principles of capitalism, community growth patterns, taxes, and other related economic concepts. This course may be used for the California Broker's License. This course has the option of a letter grade or pass/no pass. May be repeated three times for credit. ADVISORY: Real Estate 160

10951	Lec	PB13	Frimann G	6.6	3.0	TR	0630-0935
10/22/09 - 12/15/09							

Skin Care: see COS 220, 221

SOCIOLOGY

SOC 1A Introduction to Sociology

Transferable: CSU, UC; CSU-GE:D0, IGETC:4J; GAV-GE:D2; CAN:SOC2

Analysis of the structure and dynamics of human society focusing on the development of culture, the socialization process, group behavior, social inequality, deviance, sexism, racism, and ageism, major social institutions, and human ecology. Emphasizes contemporary American society. ADVISORY: Eligible for English 250 and English 260.

10055	Lec	SS210	Kreider R	3.2	3.0	MW	0945-1105
10052	Lec	SS205	Choi S	3.2	3.0	TR	0230-0350
10053	Lec	MHG10	Kreider R	3.3	3.0	T	0600-0905
Above class meets at Morgan Hill Community site.							
10054	Lec	SS206	Cervantes E	3.3	3.0	W	0600-0905
10062	ONLINE	Kreider R		3.0			

You must have an email account to take this course. Start your course by going to www.gavilan.edu/disted. Unless you have made prior arrangements with the instructor, you MUST log on by 11:59 pm on the first day of the semester. Late adds must login within 24 hours of adding this course. If you miss the deadline you may be dropped. For help, contact your instructor or email disted@gavilan.edu.

Make a difference.
Your voice counts.



Barak Obama

POLS 27
Contemporary Leadership

CRN# 10959

Tu/Th

9:45 - 11:05 am

N/S Lounges in the Student Center

Also listed as PSYC 27

ASB Associated Student Body

Today –
Shaping the policies of the college.

Tomorrow –
Shaping the policies of the world.

Join Student Government
(408) 848-4777

CRN Type Room Instructor Hrs. Units Days Begin-End

SOC 1B Introduction to Sociology: Social Problems

Transferable: CSU, UC; CSU-GE:D0, IGETC:4J; GAV-GE:D2; CAN:SOC4

Sociology 1B is a course centering on the application of sociological concepts to the analysis of human ecology, social movements, social change, deviance and other selected social problems. Emphasis is placed on the study and analysis of problems in contemporary American society. ADVISORY: Sociology 1A

10056	Lec	SS210	Kreider R	3.2	3.0	TR	0945-1105
This service learning section involves community work. See page 64 for details.							

SOC 3 Sociology of Race, Ethnicity and Cultural Identity

Transferable: CSU, UC; CSU-GE:D0, IGETC:4J; GAV-GE:D2, F

This course is designed to introduce students to the basic sociological concepts and theories of race, ethnicity and cultural identity in U.S. society. Students will examine race, ethnicity and cultural identity as social constructs that permeate social structures and institutions, and how they change over time and space. Over the semester students will critically analyze the ways which race, ethnicity, class, and gender/sexuality continually shape peoples lives and experiences. While the class focuses on U.S. societies, students will also critically compare and contrast race and ethnicity in other societies. ADVISORY: Eligible for English 250 and English 260.

10059	Lec	HU104	Choi S	3.2	3.0	TR	1250-0210
-------	-----	-------	--------	-----	-----	----	-----------

SOC 4 Sociology of Women and Men

Transferable: CSU, UC; CSU-GE:D0, D4, IGETC:4J; GAV-GE:D2

Analysis of the nature of women's and men's traditional and changing roles in society including development of women's and men's potential, relationships in marriage, influence of mass media, employment practices, legal provisions and women's and men's liberation. ADVISORY: Eligible for English 250 and English 260.

10060	Lec	SS205	Kreider R	3.2	3.0	MW	1120-1240
10061	Lec	SS210	Sachs L	3.3	3.0	T	0600-0905

CRN Type Room Instructor Hrs. Units Days Begin-End

SOC 10 Mass Media and Society

Transferable: CSU, UC; CSU-GE:C2, D0, IGETC:4J; GAV-GE:C2, D2

This course helps us understand the 20th century revolution in mass media by focusing on the history, economics and social impact of the newspaper, book publishing, magazine, film, television, public relations, advertising and music industries. We will study audience, propaganda and mass communication theory; we will discuss new technology, ethnic media in the U.S., ethical issues and attempts to regulate or control the media. Honors students will complete more in-depth analysis of media issues, and will finish a media-related research project. This course is also listed as JOUR 10. This course has the option of a letter grade or pass/no pass. ADVISORY: English 250, English 260

10050	Lec	SS205	Janes J	3.2	3.0	MW	0810-0930
-------	-----	-------	---------	-----	-----	----	-----------

SOC 21 Marriage and the Family

Transferable: CSU; CSU-GE:E2; GAV-GE:E2

Survey of information on preparation for marriage, including dating, courtship, engagement, mate selection, adjustment and parenthood. Time will also be spent on the study of families and how they function. ADVISORY: Eligible for English 250 and English 260.

10057	Lec	LS101	Hinn G	3.2	3.0	TR	0945-1105
-------	-----	-------	--------	-----	-----	----	-----------

10058	Lec	HOL2	Fault M	3.3	3.0	M	0600-0905
-------	-----	------	---------	-----	-----	---	-----------

Above class meets at the Hollister Briggs site.

SPANISH

SPAN 1A Elementary Spanish

Transferable: CSU, UC; CSU-GE:C2; GAV-GE:C2; CAN:SPAN2, SPAN SEQ A

Beginning course with emphasis on understanding and speaking Spanish; introduction to reading and writing Spanish. This course will also introduce students to Hispanic culture and institutions. This course has the option of a letter grade or pass/no pass.

10725	Lec	ARR	HU105	Marques A	5.2	5.0	MTWR	0810-0915
				TBA	2.8			

10729	Lec	ARR	HU105	Marques A	5.2	5.0	MTWR	0945-1050
				TBA	2.8			

10724	Lec	ARR	HOL1	Perez D	5.2	5.0	MTWR	0945-1050
				TBA	2.8			

Above class meets at the Hollister Briggs site.

10726	Lec	ARR	HU105	Perez D	5.2	5.0	MTWR	1250-0155
				TBA	2.8			

10732	Lec	ARR	HU105	Perez D	5.2	5.0	MTWR	0230-0335
				TBA	2.8			

CRN Type Room Instructor Hrs. Units Days Begin-End

SPAN 1B Elementary Spanish

Transferable: CSU, UC; CSU-GE:C2, IGETC:6A; GAV-GE:C2; CAN:SPAN4, SPAN SEQ A

Continuation of Spanish 1A. Further development of the four skills of understanding, speaking, reading and writing Spanish. This course will continue to emphasize the study of Hispanic culture and institutions. This course has the option of a letter grade or pass/no pass. ADVISORY: Spanish 1A or equivalent.

10738	Lec	ARR	HOL1	Perez D	5.2	5.0	MTWR	0810-0915
				TBA	2.8			

Above class meets at the Hollister Briggs site.

10733	Lec	ARR	HU105	Marques A	5.2	5.0	MTWR	1120-1225
				TBA	2.8			

10735	Lec	ARR	HU101	Schalesky C	5.2	5.0	MTWR	1250-0155
				TBA	2.8			

SPAN 2A Intermediate Spanish

Transferable: CSU, UC; CSU-GE:C2, IGETC:3B, 6A; GAV-GE:C2; CAN:SPAN8, SPAN SEQ B

Review of basic structures through conversation and selected works of literature. Further expansion of patterns, vocabulary and idioms. Creative expression through discussion and composition. This course has the option of a letter grade or pass/no pass. ADVISORY: Spanish 1B or equivalent.

10743	Lec	ARR	HU103	Malone S	5.2	5.0	TR	1250-0310
				TBA	2.8			

10740	Lec	ARR	AR103	Schalesky C	5.2	5.0	MW	0230-0450
				TBA	2.8			

SPAN 8A Conversational Spanish

Transferable: CSU; GAV-GE:C2

This course is a beginning Spanish course, focusing on the Spanish sound system, basic grammar and vocabulary, and cultural elements. Although emphasis is on listening and speaking, basic reading and writing skills will be developed. This course has the option of a letter grade or pass/no pass.

10747	Lec	ARR	HOL1	Polo I	3.3	3.0	M	0600-0905
				TBA				

Above class meets at the Hollister Briggs site.

10748	Lec	ARR	HU105	Adams P	3.3	3.0	W	0630-0935
				TBA				

SPAN 8B Conversational Spanish

Transferable: CSU; GAV-GE:C2

This course requires knowledge of Spanish pronunciation, basic vocabulary, and present tense grammar. More advanced grammar and vocabulary, and cultural elements will be taught in the development of listening, speaking, basic reading and writing skills. This course has the option of a letter grade or pass/no pass. ADVISORY: Spanish 8A or equivalent.

10749	Lec	ARR	HOL2	Lemos C	3.3	3.0	W	0600-0905
				TBA				

Above class meets at the Hollister Briggs site.



Gavilan College goes social!



Stay connected with Gavilan College at MySpace, Facebook and Twitter.

CRN Type Room Instructor Hrs. Units Days Begin-End

SPAN 8C Conversational Spanish

Transferable: CSU; GAV-GE:C2

This course requires considerable knowledge of Spanish pronunciation, vocabulary, grammar and syntax. More advanced grammar and vocabulary will be taught in the development of listening, speaking, reading and writing skills. ADVISORY: Spanish 8B or equivalent.

10750 Lec HU105 Adams P 3.3 3.0 M 0630-0935

SPAN 8D Conversational Spanish

Transferable: CSU; GAV-GE:C2

This course requires fluency in spoken and written Spanish. Advanced grammar and vocabulary will be presented while the course concentrates on polishing the student's oral and written skills and develops a sense of style. ADVISORY: Spanish 8C or equivalent.

10753 Lec HU105 Adams P 3.3 3.0 M 0630-0935

SPAN 12A Spanish for Spanish Speakers

Transferable: CSU, UC; CSU-GE:C2, IGETC:6A; GAV-GE:C2, F

Through comparative analysis of selected literary works, the course develops an awareness of cultural and literary contributions from Mexico and other Spanish speaking societies. The course is taught in Spanish with emphasis on composition as a medium of expression. This course has the option of a letter grade or pass/no pass. ADVISORY: Basic Spanish reading and writing skills.

10723 ONLINE Malone S 5.0

You must have an email account to take this course. Start your course by going to www.gavilan.edu/disted. Unless you have made prior arrangements with the instructor, you MUST log on by 11:59 pm on the first day of the semester. Late adds must login within 24 hours of adding this course. If you miss the deadline you may be dropped. For help, contact your instructor or email disted@gavilan.edu.

SPAN 23 Independent Study

Transferable: CSU

Designed to afford selected students specialized opportunities for exploring areas at the independent study level. The courses may involve extensive library work, research in the community, or special projects. May be repeated until six units of credit are accrued. This course has the option of a letter grade or pass/no pass. REQUIRED: The study outline prepared by the student and the instructor must be filed with the department and the dean.

10755 Ind HU110 Marques A 1.0
 10759 Ind HU108 Perez D 1.0
 10757 Ind HU110 Marques A 2.0
 10761 Ind HU108 Perez D 2.0

Speech: see Communications
 Statistics: see Mathematics

THEATRE ARTS / DRAMA / TELEVISION

Television: see Mass Media, Theatre Arts

THEA 1 Theatre History

Transferable: CSU, UC; CSU-GE:C1, IGETC:3A; GAV-GE:C1, F

A survey of the history of theatrical performance, production and dramatic literature, including: early Greek, Roman, Asian, the Renaissance, Italian, English, modern European to contemporary American theatre. ADVISORY: Eligible for English 250 and English 260.

10768 Lec TH125 Lawton-Haehl J 3.2 3.0 MW 0945-1105

THEA 2A Children's Theatre Repertory

Transferable: CSU; GAV-GE:C1

This course focuses on formal dramatic presentations for child audiences. Activities will include acting, set design, costuming and makeup. ADVISORY: None. May be taken out of sequence.

10786 L/L TH125 Lawton-Haehl J 4.6 2.0 TR 0900-1105



THEA 1 Theatre History

Learn about major artistic and cultural movements, read plays and texts from a variety of periods and analyze films of the historic texts in this exciting face-to-face class.

THEA 1 satisfies the ARTS requirement under the CSU-GE (Area C-1), the IGETC (Area 3A) and the AA/AS (Area C-1) Degree patterns.

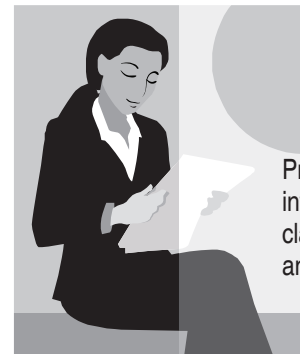

also listed as CMUN 2

THEA 4 Oral Reading 3 units

Instructor: Dr. John Lawton-Haehl

Prepare, analyze and orally present and interpret great works of drama including classical and contemporary prose, poetry and drama and literature for an audience!

Satisfies the Arts requirement (Area C-1) of the GE-CSU and the Gavilan AA/AS Degree. Use as a UC elective.

CRN Type Room Instructor Hrs. Units Days Begin-End

THEA 2B Children's Theatre Repertory

Transferable: CSU; GAV-GE:C1

Preparation and performance of touring plays for young audiences. Special activities in creative dramatization, improvisation and script development will be studied. ADVISORY: None. May be taken out of sequence.

10787 L/L TH125 Lawton-Haehl J 4.6 2.0 TR 0900-1105

THEA 3 El Teatro Campesino

Transferable: CSU, UC; CSU-GE:C1, IGETC:3A; GAV-GE:C1

Reading, viewing and discussing the work of writer/director Luis Valdez and El Teatro Campesino (The Farmworkers Theatre) is the focus of this course. It traces the historical development of the theatrical company from its creation in 1965 to the present. Students will read actos, plays and view theatrical productions performed by El Teatro Campesino. This course has the option of a letter grade or pass/no pass. ADVISORY: Eligible for English 250 and English 260.

10788 ONLINE Gonzalez R 3.0

10/05/09 - 12/19/09 You must have an email account to take this course. Start your course by going to www.gavilan.edu/disted. Unless you have made prior arrangements with the instructor, you MUST log on by 11:59 pm on the first day of class. Late adds must login within 24 hours of adding this course. If you miss the deadline you may be dropped. For help, contact your instructor or email disted@gavilan.edu.

THEA 4 Oral Reading

Transferable: CSU, UC; CSU-GE:C1; GAV-GE:C1

An introduction to the analysis, preparation and dramatic reading of literature, including classical and contemporary prose, poetry and drama. Students prepare, analyze and orally present and interpret great works of drama and literature for an audience. This course is also listed as CMUN 2. ADVISORY: Eligible for English 250 and English 260.

10789 Lec TH125 Lawton-Haehl J 3.2 3.0 TR 1120-1240

CRN Type Room Instructor Hrs. Units Days Begin-End

THEA 12A Acting: History and Practice

Transferable: CSU, UC; CSU-GE:C1; GAV-GE:C1; CAN:DRAM8

An introduction to the historical development of acting as a practice of human cultural expression. Students will acquire a vocabulary for theatre performance as an art form and analyze dramatic works in a historical context. Practice of basic acting concepts, character analysis, preparation and performances of monologues and scenes will be required in the course.

10769	L/L ARR	TH125	Lawton-Haehl J TBA	3.2 2.0	3.0	MW	1120-1240
-------	------------	-------	-----------------------	------------	-----	----	-----------

THEA 12B Acting Techniques

Transferable: CSU, UC; GAV-GE:C1

Techniques for creating characterizations for performance. Various acting approaches will be examined through research, discussion and acting exercises. This course has the option of a letter grade or pass/no pass. May be repeated two times for credit. ADVISORY: Theatre Arts 12A.

10770	L/L ARR	TH125	Lawton-Haehl J TBA	3.2 1.0	2.0	MW	1120-1240
-------	------------	-------	-----------------------	------------	-----	----	-----------

THEA 14 Stage Production

Transferable: CSU, UC; GAV-GE:C1

An individualized course in technical theatre production for the performing arts. Areas of study include: scenery, lighting, props, costumes, sound, make-up, public relations/box office management or stage management. May be repeated until a maximum of 9 units are accrued. ADVISORY: Eligible for English 250 and English 260.

10771	Lab	TH125	Lawton-Haehl J	3.2	1.0	MW	1250-0210
10772	Lab	TH125	Klipstine W	6.6	2.0	MW	1250-0355
10773	Lab ARR	TH125	Klipstine W TBA	6.6 3.0	3.0	MW	1250-0355

THEA 16 Television History and Practice

Transferable: CSU; GAV-GE:C1

This course examines theories, history and development of television technology and current distribution practices. Programming genres and production techniques are analyzed, evaluated and compared with other societies as tools of mass communication. This course is also listed as MCTV 16. ADVISORY: Eligible for English 250 and 260.

10774	Lec	LI140	Abad M	3.2	3.0	MW	1120-1240
-------	-----	-------	--------	-----	-----	----	-----------

THEA 17A Television and Video Workshop

Transferable: CSU; GAV-GE:C1

An introduction to television and video technology, including pre-production, production and post-production techniques such as: camera work, studio equipment, lighting, audio plus off-line and on-line editing. This course is also listed as MCTV 17A. ADVISORY: Theatre Arts 16 Intro to TV or consent of instructor.

10775	L/L	LI140	Frazier J	5.4	3.0	TR	1250-0315
-------	-----	-------	-----------	-----	-----	----	-----------

CRN Type Room Instructor Hrs. Units Days Begin-End

THEA 17B Television and Video Workshop

Transferable: CSU; GAV-GE:C1

Emphasis placed on production and post-production techniques in video production. Student knowledge and skills are increased by participating in live to tape projects. May be repeated twice for credit. This course is also listed as MCTV 17B. ADVISORY: Completion of Theatre Arts 17A.

10776	Lab	LI140	Frazier J	5.4	3.0	TR	1250-0315
-------	-----	-------	-----------	-----	-----	----	-----------

THEA 19 Television and Film Acting

Transferable: CSU, UC; GAV-GE:C1

Theory and practice of acting for film and television. Students will learn basic performance techniques for the camera. Learning experiences include projects in broadcasting, reporting, commercials, public service announcements (psa), comedy and drama. This course has the option of a letter grade or pass/no pass. May be repeated three times for credit. This course is also listed as MCTV 19.

10777	L/L	LI140	STAFFS	3.2	3.0	TR	1120-1240
-------	-----	-------	--------	-----	-----	----	-----------

THEA 20 Introduction to Scriptwriting

Transferable: CSU; CSU-GE:C1

An introductory course on script development, writing and formatting for broadcast television and film production. This course has the option of a letter grade or pass/no pass. May be repeated three times for credit. ADVISORY: English 250

10778	ONLINE	Gonzalez R	3.0				
10/05/09 - 12/19/09 You must have an email account to take this course. Start your course by going to www.gavilan.edu/disted . Unless you have made prior arrangements with the instructor, you MUST log on by 11:59 pm on the first day of class. Late adds must login within 24 hours of adding this course. If you miss the deadline you may be dropped. For help, contact your instructor or email disted@gavilan.edu .							

THEA 22 Field Work and Service

Transferable: CSU

Supervised field work within the college and with local agencies. Students serve in useful group activities in leadership roles prescribed for them by faculty or community agencies. A maximum of six units may be completed. This is a pass/no pass course. REQUIRED: Learning contracts must be filled out and signed by the student and the supervising instructor.

10779	Fld Ex	LI140	Abad M	.5			
-------	--------	-------	--------	----	--	--	--

THEA 23 Independent Study

Transferable: CSU

Designed to afford selected students specialized opportunities for exploring areas at the independent study level. The courses may involve extensive library work, research in the community, or special projects. May be repeated until six units of credit are accrued. This course has the option of a letter grade or pass/no pass. REQUIRED: The study outline prepared by the student and the instructor must be filed with the department and the dean.

10780	Ind	TH125	Abad M	1.0			
10782	Ind	LI140	Frazier J	1.0			
10784	Ind	TH125	Lawton-Haehl J	1.0			
10781	Ind	TH125	Abad M	2.0			
10783	Ind	LI140	Frazier J	2.0			
10785	Ind	TH125	Lawton-Haehl J	2.0			



Enter the world of live entertainment!!!

Gain self-confidence through theatre and acting!

THEA 12A satisfies the Arts requirement (Area C-1) of the GE-CSU and the Gavilan AA/AS Degree. Use either as UC electives.

THEA 12A
Acting: History & Practice

THEA 12B
Acting Techniques

CRN Type Room Instructor Hrs. Units Days Begin-End

THEA 78 Dance Repertory

Transferable: CSU

Study, rehearse and perform choreography provided by faculty, guest artists and/or student choreographers. Opportunities to perform at informal settings at the college and various locations in the Gavilan community. The class includes dance warm up and work on technical skills, improvisational study, creating choreographic studies for group and solo forms and rehearsal and performance of finished dances either for the class, college or community. May be repeated three times for credit. This course has the option of a letter grade or pass/no pass. Also listed as PE 78. ADVISORY: An ability to perform more complex patterns of movement with a strong level of dance technique: or Current enrollment in a dance class: or Permission of the instructor.

10948 Lab TH125 Lawton-Haehl J 3.3 1.0 S 1000-0105

THEA 98 Special Topics

Transferable: CSU

Special topics courses examine current problems or issues of interest to students within a specific discipline area. For topical content information, consult with the appropriate department chairperson. For transfer status, check with a counselor. This course may have the option of a letter grade or pass/no pass.

10792 Lec LI140 Abad M 2.3 .5 T 1120-0125
10794 Lec LI140 Abad M 3.3 3.0 T 1120-0225

Word Processing: see CSIS

WORK EXPERIENCE

CWE 190 Occupational Work Experience

Transferable: CSU

Occupational work experience for students who have a job related to their major. A training plan is developed cooperatively between the employer, college and student. (CR/NC grading) 75 hours per semester paid work = 1 unit. 60 hours non-paid (volunteer) work per semester = 1 unit. May be taken for a maximum total of 16 units. REQUIRED: Declared vocational major. Concurrent enrollment in seven or more units (including CWE units, except for summer school. For summer school, enrollment in one other class is required). Minimum 2.00 G.P.A.

Mandatory course orientation for the following classed will be conducted Tuesday October 6, 2009 from 530 pm-630 pm the North/South Lounge, Wednesday, October 7, 2009 from 430 pm -530 pm in the North/South Lounge and Thursday October 8, 2009 from 8 am to 9 am in the North/South Lounge. Students need to attend one of the three meetings. Please contact Susan Sweeney, CWE Coordinator at (408) 848-4813 for more information.

10834 Wrk Ex LI101A Sweeney S 1.0
10835 Wrk Ex LI101A Sweeney S 2.0
10836 Wrk Ex LI101A Sweeney S 3.0
10837 Wrk Ex LI101A Sweeney S 4.0

CWE 192 General Work Experience Education

Transferable: CSU

General work experience for students who have a job unrelated to their major. General work experience is supervised employment which is intended to assist students in acquiring desirable work habits, attitudes and career awareness. A training plan is developed cooperatively between the employer, college and student. (CR/NC grading) 75 hours per semester paid work = 1 unit. 60 hours non-paid (volunteer) work per semester = 1 unit. May be taken for a maximum of 16 units. REQUIRED: Concurrent enrollment in seven or more units (including CWE units, except for summer school. For summer school, enrollment in one other class is required) Minimum 2.00 G.P.A.

Mandatory course orientation for the following classed will be conducted Tuesday October 6, 2009 from 530 pm-630 pm the North/South Lounge, Wednesday, October 7, 2009 from 430 pm -530 pm in the North/South Lounge and Thursday October 8, 2009 from 8 am to 9 am in the North/South Lounge. Students need to attend one of the three meetings. Please contact Susan Sweeney, CWE Coordinator at (408) 848-4813 for more information.

10838 Wrk Ex LI101A Sweeney S 1.0
10839 Wrk Ex LI101A TBA 2.0
10840 Wrk Ex LI101A Sweeney S 3.0



Broadcast Television
Certificate of Proficiency

THEA14 Stage Production 2 units
THEA/MCTV 16 Introduction to Television 3 units
THEA/MCTV 17A Television and Video Workshop. 3 units
THEA/MCTV 17B Television and Video Workshop. 3 units
THEA/MCTV 19 Television and Film Acting 3 units

Choose one of the following courses:

THEA 6 Introduction to Audio Production (3 units)
THEA 20 Introduction to Scriptwriting (3 units)

. 3 units

Total Units for Certificate of Proficiency: 17 UNITS



Be a part of the cameras, lights, action!

THEA 98 - GAVTV 18
The Gavilan Educational Station



INTERESTED? CHECK OUT OUR WEBSITE:
<http://www.gavilan.edu/gavtv/index.html>

Check out a NEW DISCIPLINE!
MCTV: Mass Communications & Television



THEA 78
Dance Repertory
Sat 10-1 (1 unit)

This term will focus on folk dances from Mexico & Folklórico.

Featuring Dances and choreographers from Ballet Fuego Nuevo and Fiesta Mexicana.

CRN Type Room Instructor Hrs. Units Days Begin-End

VOCATIONAL PREP STUDENTS: DISABILITY

AE 600 Vocational Training I

Transferable: No

Prevocational skills for adults with impaired cognitive functioning. Entry level work preparation is emphasized. Skills taught include basic work routine orientation, communication skills, job ability assessment, and self-management skills.

10408 Lab HOPEH Brown C/Sato K
Class meets at HOPE Workshop, 2300 Technology Parkway, Hollister. Open Entry - Open Exit.

10448 Lab LI204 Franklin L
Open Entry - Open Exit.

10459 Lab HOPEG Merrill T/Brown C/ Sato K
Class meets at HOPE Workshop, 8855 Murray Ave., Gilroy. Open Entry-Open Exit.

10477 Lab LI117 Brown C 7.0 W 0910-0400
Merrill T
Open Entry-Open Exit.

10461 Lab MHG3 Merrill T 4.3 M 0945-0150
Class meets at Morgan Hill Community site. Open Entry-Open Exit.

10463 Lab LI171 Sato K 2.0 TR 0910-1000
Open Entry-Open Exit.

10486 Lab GY131G Sato K 2.0 TR 1010-1110
Open Entry-Open Exit.

10492 Lab APE120/121 Brown C 3.2 TR 1120-1240
Open Entry-Open Exit.

AE 602 Vocational Training III

Transferable: No

Practical training and on-the-job work experience for students with disabilities. This course also provides preparation for entry level employment utilizing a number of work alternatives and settings.

10499 Lab HOPEG Merrill T/Brown C
Class meets at HOPE Workshop 88
55 Murray Avenue, Gilroy. Open Entry-Open Exit.

10506 Lab HOPEH Sato K/Brown C
Class meets at HOPE Workshop, 2300 Technology Parkway, Hollister. Open Entry-Open Exit

10507 Lab LI204 Franklin L
Open Entry-Open Exit.

CRN Type Room Instructor Hrs. Units Days Begin-End

AE 603 Vocational Training IV

Transferable: No

AE 603 is a job readiness course which provides opportunities for individuals with disabilities to participate in service-learning activities and job readiness training leading to job development and placement in a community setting.

10508 Lab LI204 Franklin L
Open Entry-Open Exit.

10510 Lab MHG8 Merrill T 3.3 F 0945-1250
Above class meets at Morgan Hill Community site. Open Entry-Open Exit.

AE 605 Vocational Training VI

Transferable: No

This course is designed for students with disabilities. The purpose of this course is to improve the student's ability to participate in the community, by increasing independence through acquisition of survival vocabulary, structured practice in functional reading utilizing phonics and content recognition, and increased enjoyment in reading for pleasure. Students will read stories written or revised specifically for adults with limited reading skills.

10513 L/L APE120/121 Brown C 1.6 R 1250-0210
Open Entry-Open Exit

AE 613 Independence Training IV

Transferable: No

This course is designed for students with disabilities. The purpose of this course is to improve the student's ability to build math competencies related to independence in daily living and the work site. The focus of the class is basic computation, consumer awareness, money management, banking and purchasing.

10519 L/L APE120/121 Brown C 1.6 T 1250-0210
Open Entry-Open Exit.

AE 636 Adapted Physical Education

Transferable: No

An individualized program of adapted physical education activities designed to meet the needs of students who have physical limitations or disabilities. The course assists in the development and appreciation of physical activity as a regular planned contribution to one's overall well-being. This course is for the non-matriculating student, is not graded and is without college credit. ADVISORY: Students must be able to document a physical disability.

10520 Lab GY100P Ellis D
Open Entry-Open Exit.

10523 Lab LOADCS1 Sato K 3.2 MW 0945-1105
Class meets at Live Oak Adult Day Services, 651 West Sixth St., Gilroy.

10525 Lab LOADCS1 Maringer J 3.2 TR 0945-1105
Class meets at Live Oak Adult Day Services, 651 West Sixth St., Gilroy. Open Entry-Open Exit.

10526 Lab LOADCS1 Maringer J 3.3 F 0945-1250
Class meets at Live Oak Adult Day Services, 651 West Sixth St., Gilroy. Open Entry-Open Exit

10527 Lab APE101/108 Ellis D 3.3 F 0945-1250
Specialized class for students with developmental disabilities. Open Entry-Open Exit.

GoPrint You can now use the GoPrint system to print documents at all of Gavilan College's computer labs. No need to fumble around with coins! With your GoPrint or ASB card, you're good to go. See ad on page 8.



CMAP CHANNELS
CITYVIEW 17
GAV-TV 18
ED-TV 19
PUBLIC ACCESS 20

CMAP is a non-profit community media center and cable access television station located at Gavilan College in L-139 in Gilroy.

CMAP offers:

- Local Government, Education and Community TV
- Professional equipment and free or low-cost classes in Video Production, Filmmaking, Digital Storytelling, Green Screen and Editing in Final Cut Pro/Sony Vegas to document your life, your community and your stories in multimedia.

We can train you how to make your own TV & YouTube videos and offer summer educational camps for kids.

For more information or to get involved, stop by CMAP in L-139, or visit www.cmap.tv for our orientation and class schedule or call 408.846.4983.

Available to residents of Gilroy, Hollister, San Juan Bautista and Morgan Hill, and GAV students.

www.cmap.tv

NONCREDIT PROGRAM

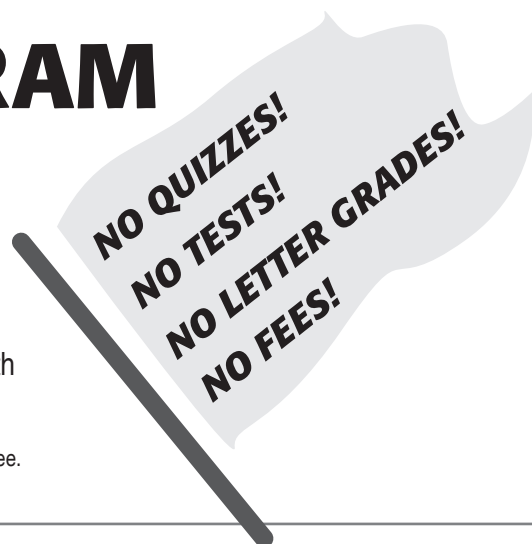

This program is open to all students and currently offers various classes of interest to the community. All classes are free of charge.* There are no tests, no quizzes and no letter grades. Registration will take place in the Admissions & Records Office or on the first day of class. Students should contact Debra Casella in the Noncredit Office directly with any questions at (408) 852-2824.

* Some classes may require a materials fee.

Noncredit ESL Program

ESL Lifeskills 1 - 6

This program consists of a series of survival English classes for students with very little oral or written English. It gives students basic vocabulary and familiarity in life skills areas such as the family, food, health and different occupations to manage their lives in the real world.

Vocational ESL (Workplace Communications)

These courses are designed for ESL students who want to prepare for immediate entry into the job force. Students expand their language skills and learn specific vocational career of interest while developing soft skills needed in the workplace.

Parenting Program

Classes such as Parent Advocacy are sometimes offered.

Basic Skills Program

This program assists adult learners with their educational needs in areas of learning English, preparing for citizenship, and improving their basic skills in reading, writing and Math. Classes include:

- Development of Writing Skills
- ESL Citizenship
- GED Preparation
- Introduction to Online Gavilan
- Personal and Career Development
- CAHSEE Preparation (High School Exit Exam)
- ESL Life Skills
- Writers' Workshop

Adults 55+

This program offers special interest classes to adults 55 and older. Our classes take place at various older adult facilities as well as Gavilan campuses to ensure positive enrollment and convenience for the students.

FALL NONCREDIT CLASSES

CRN Type Room Instructor Hrs. Units Days Begin-End

ALLIED HEALTH

AH 740 Tai Chi for Arthritis and Other Related Illnesses

Transferable: No

This course is designed for the maintenance of the physical and mental well-being of an older adult with arthritis and other related illnesses. Instruction will focus on the postures and movements of Tai Chi, a Chinese exercise regimen that has a slow paced movement that improves balance, coordination, breathing and builds strength and stamina. Activities are included that promote self-care and health awareness.

11012 Lab WM1 Yinger K 2.0 TR 1000-1100
Above class meets at Wheeler Manor 651 W. 6th St. in Gilroy.

11013 Lab JDA1 Frey E 1.0 R 1115-1215
Above class meets at Jovenes de Antano 300 West St. in Hollister.

11011 Lab CRC1 Dunn M 1.8 W 0600-0730
Above class meets at Centennial Recreation Center, 171 W. Edmundson Ave. in Morgan Hill.

All noncredit classes are open entry/exit and free of charge.

CRN Type Room Instructor Hrs. Units Days Begin-End

AH 741 Body Dynamics and Aging

Transferable: No

This course is designed for the 55+ adult student to provide awareness and knowledge of physical fitness, stress management and nutrition to personal health. Discussions will focus on nutrition, sleep disorders, depression, leisure/social activities and chronic conditions that effect the body as aging occurs.

11027 Lec CRC1 Lee C 1.8 W 1030-1200
Above class meets at Centennial Recreation Center, 171 W. Edmundson Ave. in Morgan Hill.

AH 742 Coping with Loss

Transferable: No

In this course, the older adult will learn that grief and loss are an integral part of the human experience and they are not alone and that grief is universal. Specific topics will include: the process of normal grieving, tools for effective coping, signs of depression, resiliency skills, and resources available in the community and redefining one's life after a loss.

11026 Lec HSC Elmhurst D 2.0 M 0630-0830
Above class meets at Hillside Church in Hollister.

AH 793 Personal and Career Development

Transferable: No

A wide variety of lectures on general themes offered to students throughout the academic year who want short-formatted content to augment their personal, academic and career development. General themes to be explored are: Communication, Interpersonal Skills, Pre- employment, Decision-Making, Financial Literacy, Career and Personal Development and Self-Management with Nutrition. This noncredit course is a combination of lecture, self-assessments, group activities and individual modules.

11031 Online LI100 Sweeney S 6.0 WR 0430-0730
09/01/09 - 12/31/09 This Hybrid lecture/online class will be delivered partially over the internet and also meet face to face at select locations. You must have an email account to take a distance ed course. **H** Unless you have made prior arrangements with the instructor, come to class in person on the first day of the semester or the first day of class for short-term courses. If you do not show up on the first day you may be dropped. For help, contact your instructor or email disted@gavilan.edu.

ART

ART 760 Arts and Crafts I for Older Adults

Transferable: No

A general survey of arts and crafts with an emphasis on exercises and experiments with methods and materials, including: painting, drawing, color theory, composition and rendering, batik or tie-dye, quilting or needlepoint, crocheting or knitting and block printing.

11029 Lab WM1 Barrett S 3.0 M 0100-0400
Above class meets at Wheeler Manor 651 W. 6th St. in Gilroy. Student's will be required to pay for materials.

11030 Lab CRC1 Gupta R 3.0 R 0100-0400
Above class meets at Centennial Recreation Center, 171 W. Edmundson Ave. in Morgan Hill. Student's will be required to pay for materials.

All noncredit classes are open entry/exit and free of charge.

CRN Type Room Instructor Hrs. Units Days Begin-End

ART 761 Arts and Crafts II for Older Adults

Transferable: No

A general survey of arts and crafts with an emphasis on exercises and experiments with methods and materials, including: Metal, leather, fibers, glass, wood, and paper crafts. The crafts will be for both decorative or utilitarian.

11028 Lab HVME1 Dickerson P 3.0 F 0900-1200
Above class meets at Hacienda Valley Mobile Estates, 275 Burnett Ave. in Morgan Hill. Student's will be required to pay for materials.

COMPUTER SCIENCE & INFORMATION SYSTEMS

CSIS 728 Windows for the Older Adult

Transferable: No

This course is designed as an introductory course for the older adults to learn Windows operations, file management and other Windows Fundamentals.

10988 Lab HOL3 TBA 2.0 TR 0330-0430
Above class meets at the Hollister Briggs site.

11009 Lab CTC2 TBA 2.8 T 0900-1130
Above class meets at Gavilan Computer Technology Center (Room 2) on Murray Ave. in Gilroy.

CSIS 729 Word Processing-MS Word for the Older Adult

Transferable: No

A course designed for older adults (55+) to develop word processing skills to write and edit simple documents, format text, use bullets, create tables, insert clipart and use other features of the toolbar.

11022 Lec CTC2 TBA 2.8 R 0900-1130
Above class meets at Gavilan Computer Technology Center (Room 2) on Murray Ave. in Gilroy.

ENGLISH

ENGL 749 Writers' Workshop

Transferable: No

Writers' Workshop is an open enrollment class that allows community members and students from all disciplines to participate in a regularly scheduled, instructor-facilitated writing response group. Activities include focused response to participants' writing, generative writing games and prompts and interaction with visiting writers and scholars.

10989 Lec GLEN Smith K 3.0 W 0130-0430
Above class meets at Glenview Elementary (Family Academy Room) 480 Eighth St. in Gilroy.

ENGL 750 Creative Writing Workshop for Older Adults

Transferable: No

A class designed for older adults to develop their writing skills in a peer support group. They are guided in creative expression through prose and poetry. Older adults are encouraged to read their works in class and learn how to respond to writing, guided creative exercises and assignments, sentence and story structure.

11024 Lec CRC1 Kirchner V 1.8 M 0930-1100
Above class meets at Centennial Recreation Center 171 W. Edmundson Ave. in Morgan Hill.

CRN	Type	Room	Instructor	Hrs.	Units	Days	Begin-End
-----	------	------	------------	------	-------	------	-----------

ENGL 756 GED Preparation**Transferable:** No

This course is designed to prepare the student to pass the five General Education Development (GED) tests in Writing, Social Studies, Science, Literature and Mathematics. English grammar and usage, reading comprehension, writing, vocabulary and computational skills are emphasized. The course is designed for students who are 18 years of age or older and elect to take the High School Equivalency Examination.

10981	Lab	HOL3	Miguel B	3.0	S		0100-0400
-------	-----	------	----------	-----	---	--	-----------

Above class meets at the Hollister Briggs site.

10982	Lab	HOL4	Holguin D	4.0	S		0830-1230
-------	-----	------	-----------	-----	---	--	-----------

Above class meets at the Hollister Briggs site. This class is taught in Spanish. (Esta clase se enseña en Español).

11003	Lab	CRL	TBA	4.0	MW		0400-0600
-------	-----	-----	-----	-----	----	--	-----------

09/14/09 - 12/16/09 Above class meets at Charles River Labs Park Center Dr. in Hollister.

11004	Lab	CTC2	Holguin D	2.8	T		0630-0900
-------	-----	------	-----------	-----	---	--	-----------

Above class meets at Gavilan Computer Technology Center (Room 2) on Murray Ave. in Gilroy.

11005	Lab	CTC1	Vargas-Padilla	2.8	M		0630-0900
-------	-----	------	----------------	-----	---	--	-----------

Above class meets at Gavilan Computer Technology Center (Room 1) on Murray Ave. in Gilroy. This class is taught in Spanish. (Esta clase se enseña en Español).

ENGLISH AS A SECOND LANGUAGE**ESL 702A ESL Citizenship****Transferable:** No

This course is designed for second language learners that want to prepare for the United States Citizenship test given by the Department of Immigration and U. S. Naturalization Services. The focus will be on communicative English skills and knowledge of American History and Government required for passing the test to become a citizen of the United States. Readings are at the high-beginning/low-intermediate ESL level and will focus on the historical period beginning in the 1600's on through to 1980.

10976	Lec	MHG5	Yu-Costa E	5.6	MW		0900-1130
-------	-----	------	------------	-----	----	--	-----------

Above class meets at Morgan Hill Community site.

10975	Lec	STF1	Stuker D	3.6	MR		0600-0730
-------	-----	------	----------	-----	----	--	-----------

Above class meets at St. Frances Building, 7950 Church St. in Gilroy

10977	Lec	JDA1	Segovia M	5.6	TR		0600-0830
-------	-----	------	-----------	-----	----	--	-----------

Above class meets at Jovenes de Antano, 300 West Street (Gavilan Room) in Hollister.

ESL 704A ESL for the Workplace**Transferable:** No

This is part A of a content-based integrated skills course for ESL students who want to prepare for immediate entry into the job force. Students expand their language skills within the realm of the work world and specific vocational career of interest while also developing the soft skills needed in the workplace. This course is a combination of lecture, lab, and self-paced instruction.

11006	Lab	CTC1	Rivoallon L	10.0	MTWRF		0900-1100
-------	-----	------	-------------	------	-------	--	-----------

Above class meets at Gavilan Computer Technology Center (Room 1) on Murray Ave. in Gilroy.

11008	Lab	JS1	TBA	9.0	MTW		0500-0800
-------	-----	-----	-----	-----	-----	--	-----------

Above class meets at Jasmine Square Apartments 16530 Monterey Rd. in Morgan Hill.

11007	Lab	CTC1	Vargas-Padilla	6.0	TWR		0700-0900
-------	-----	------	----------------	-----	-----	--	-----------

Above class meets at Gavilan Computer Technology Center (Room 1) on Murray Ave. in Gilroy.

CRN	Type	Room	Instructor	Hrs.	Units	Days	Begin-End
-----	------	------	------------	------	-------	------	-----------

ESL 777 ESL Lifeskills 1**Transferable:** No

This is the first course in a series of survival English classes for students with very little oral or written English competency. It will give students basic vocabulary and familiarity in life skill areas such as the family, food, health, and occupations to manage in the real world. The course emphasizes oral communication and integrates listening, speaking, reading, and writing. ADVISORY: Placement into ESL Lifeskills by the CASAS placement test.

10978	Lec	ELIOT1	Payne D	5.4	MWF		0830-1000
-------	-----	--------	---------	-----	-----	--	-----------

Above class meets at Eliot Elementary School (Cafeteria) 475 Old Gilroy Street in Gilroy.

11136	Lec	SBCCL	TBA	6.0	TR		0900-1200
-------	-----	-------	-----	-----	----	--	-----------

Above class meets at San Benito County Library 470 5th St. in Hollister.

10979	Lec	VLA1	Segovia G	5.6	TR		0600-0830
-------	-----	------	-----------	-----	----	--	-----------

Above class meets at Villa Luna Apartments, 850 Hillcrest Rd., Hollister.

10992	Lec	ROH	Gaver J	5.6	MW		0600-0830
-------	-----	-----	---------	-----	----	--	-----------

Above class meets at R.O. Hardin 881 Line St. in Hollister.

10994	Lec	CALAVR	TBA	5.4	MWF		0600-0730
-------	-----	--------	-----	-----	-----	--	-----------

Above class meets at Calaveras Elementary 1151 Buena Vista Rd. in Hollister.

10993	Lec	BROWNL	Camacho-Light	6.0	TWR		0700-0900
-------	-----	--------	---------------	-----	-----	--	-----------

Above class meets at Brownell Elementary 7800 Carmel St. in Gilroy.

10995	Lec	CALAVR	TBA	5.4	MWF		0745-0915
-------	-----	--------	-----	-----	-----	--	-----------

Above class meets at Calaveras Elementary 1151 Buena Vista Rd. in Hollister.

ESL 778 ESL Lifeskills 2**Transferable:** No

This is the second course in a series of classes in survival English for students with very little oral or written English competency. It will give students basic vocabulary and familiarity in life skill areas such as the family, food, health, and occupations to manage in the real world. The course emphasizes oral communication and integrates listening, speaking, reading, and writing. ADVISORY: Placement into ESL Lifeskills by the CASAS placement test and successful completion of ESL 777.

10980	Lec	MHG13	Yu-Costa E	4.0	TR		0930-1130
-------	-----	-------	------------	-----	----	--	-----------

Above class meets at Morgan Hill Community site.

10997	Lec	SUNNY	Vallejo M	5.4	TWR		0600-0730
-------	-----	-------	-----------	-----	-----	--	-----------

Above class meets at Sunnyslope Elementary 1475 Memorial Dr. in Hollister.

ESL 779 ESL Lifeskills 3**Transferable:** No

This is the third in a series of classes in survival English for students with little oral or written English competency. It will give students expanded basic vocabulary and familiarity in life skill areas such as the weather, transportation, employment, and American holidays and customs to manage in the real world. The course emphasizes oral communication and integrates listening, speaking, reading, and writing. ADVISORY: Placement into ESL Lifeskills by the CASAS placement test and successful completion of ESL 778.

11000	Lec	CTC3	Morley S	9.0	MWF		0900-1200
-------	-----	------	----------	-----	-----	--	-----------

Above class meets at Gavilan Computer Technology Center (Room 3) on Murray Ave. in Gilroy.

10998	Lec	CRL	TBA	4.0	TR		0400-0600
-------	-----	-----	-----	-----	----	--	-----------

09/15/09 - 12/17/09 Above class meets at Charles River Labs Park Center Dr. in Hollister.

10999	Lec	SVALLY	TBA	5.4	MWF		0700-0830
-------	-----	--------	-----	-----	-----	--	-----------

Above class meets at South Valley Junior High (Room E-7) in Gilroy.

CRN Type Room Instructor Hrs. Units Days Begin-End

ESL 780 ESL Lifeskills 4

Transferable: No

This is the fourth course in a series of survival English for students with little oral or written English competency. It will give students expanded basic vocabulary and familiarity in life skill areas such as weather, transportation, employment, and American holidays and customs to manage in the real world. The course emphasizes oral communication and integrates listening, reading, writing. **ADVISORY:** Placement into ESL Lifeskills by the CASAS placement test and successful completion of ESL 779.

10985	Lec	GABILN	Howell J	5.4	MWF	0600-0730
Above class meets at the Gavilan Hills Elementary, 901 Santa Ana Rd. Suite 100 in Hollister.						

11001	Lec	GABILN	Howell J	5.4	MWF	0745-0915
Above class meets at Gavilan Hills Elementary, 901 Santa Ana Rd. Suite 100 in Hollister.						

ESL 781 ESL Lifeskills 5

Transferable: No

This is the fifth course in a series of survival English for students with beginning oral or written English competency. It will reinforce basic skills learned and continue to develop vocabulary and ease of communication in life skill areas such as the family, the larger community, health, employment, and leisure activities to manage in the real world. The course emphasizes oral communication and integrates listening, speaking, reading, and writing. **ADVISORY:** Placement into ESL Lifeskills by the CASAS placement test and successful completion of ESL 780.

11002	Lec	BURNET	Yu-Costa E	5.6	TR	0600-0830
Above class meets at Burnett Elementary 85 Tilton Ave. in Morgan Hill.						

11135	Lec	SVALLY	Magana J	5.6	MWF	0700-0830
Above class meets at South Valley Middle School, Rm E-5, 385 I.O.O.F Ave., Gilroy.						

HUMANITIES

HUM 767 Film Classics

Transferable: No

This class is designed to study the facts, fantasy, history and trivia of classic and modern films. The background and history of each film and its performance will be compared and contrasted.

11020	Lab	JDA1	Sendejas L	3.0	F	1000-0100
Above class meets at Jovenes de Antano 300 West St. in Hollister.						

11021	Lab	PLY	Richards G	3.0	W	0200-0500
Above class meets at Morgan Hill Playhouse in Morgan Hill.						

11019	Lab	WM1	Sendejas L	3.0	S	0430-0730
Above class meets at Wheeler Manor 651 W. 6th St. in Gilroy.						

LIBRARY

LIB 730 Internet Literacy for Older Adults

Transferable: No

A class for older adults to learn email techniques, how to find information on their interests, news sources, and the skill of browsing online, as well as how best to use the local public library online services, online shopping, search strategies, and interactive games.

10987	Lec	HOL3	TBA	2.0	TR	0230-0330
Above class meets at the Hollister Briggs site.						

CRN Type Room Instructor Hrs. Units Days Begin-End

LIB 732 Introduction to Online Gavilan

Transferable: No

Introduction to the online classes and student services at Gavilan College. This course will show students how to log into their online courses, find lectures, assignments and exams, take part in online class discussions, submit attachments, and view their grades. The course will also cover all the online student services available to the distant student, including counseling, library resources, records and grades, financial aid, tutoring and technical support.

10984	Online		Parker J			
-------	--------	--	----------	--	--	--

 This open-entry, open-exit online class will be delivered entirely over the Internet. After enrolling, start the class by going to <http://www.gavilan.edu/disted>, and log into the system.

LIB 733 Exploring the Web for Older Adults

Transferable: No

Designed to address the interests of older adults, students will learn about the web's rich offering in graphics, sharing digital pictures, and downloading audio files and audiobooks after paying your bills online. Students will learn online techniques to take advantage of all the latest tools, such as wikis, blogs, search techniques and great travel destinations. **ADVISORY:** LIB 730, Internet Literacy for Older Adults.

10986	Lec	HOL3	TBA	2.0	TR	0130-0230
-------	-----	------	-----	-----	----	-----------

Above class meets at the Hollister Briggs site.

PHYSICAL EDUCATION

PE 701 Tai Chi for Wellness

Transferable: No

This course will introduce the student to the thirty seven posture forms and movements of Tai Chi, an ancient Chinese practice that focuses on slow paced coordinated movements that improve balance, coordination, mobility and breathing. The students will also learn how to use this non-contact exercise program to reduce stress in their daily lives.

11010	Lab	SJBCC	Yinger K	1.0	W	0530-0630
-------	-----	-------	----------	-----	---	-----------

Above class meets at San Juan Bautista Community Center

PE 716 Music/Movement and Health

Transferable: No

This course is designed to assist older adults in improving overall health through movement, music and relaxation techniques. Rhythmical movement will be adjusted to suit individual students mobility needs.

11015	Lab	VPRI1	Lee C	1.0	T	1030-1130
	Lab	VPRI1	Lee C	1.0	W	0930-1030

Above class meets at Valley Pines Retirement Inn 545 E. Main Ave. in Morgan Hill.

11016	Lab	GSC1	Mendonca B	1.0	F	0130-0230
	Lab	GSC1	Mendonca B	1.0	W	1000-1100
	Lab	GSC1	Mendonca B	1.0	M	1100-1200

Above class meets at Gilroy Senior Center 7371 Hanna St. in Gilroy.

11017	Lab	JDA1	Host M	1.0	T	1100-1200
-------	-----	------	--------	-----	---	-----------

Above class meets at Jovenes de Antano 300 West St. in Gilroy.

11018	Lab	CRC1	Mendonca B	4.0	TF	1000-1200
	Lab	CRC1	Mendonca B	1.0	R	1030-1130

Above class meets at Centennial Recreation Center 171 W. Edmundson Ave. in Morgan Hill.

All noncredit classes are open entry/exit and free of charge.



ROP Courses

Regional Occupational Program (ROP) training is offered to residents of Santa Clara and San Benito Counties by the Santa Clara County Office of Education. Some classes are offered at Gavilan College. In some of the classes, students may earn high school or college credit, and upon completion they may be eligible for advanced placement at Gavilan College. ROP provides students with training to secure jobs, upgrade skills, or prepare for advanced career education. Students must be 16 years of age or older to participate. Classes are free for both high school students and adults. Gavilan College fees are charged for Gavilan College credit. ROP classes may have additional fees for textbooks and supplies. For information on ROP courses taught at Gavilan College, call 408-848-4816.

Students enrolled in ROP classes do not qualify for Financial Aid.

Fall classes begin September 1, 2009
REGISTER EARLY!

Gavilan College is an on-site partner in the



ONE-STOP CAREER CENTER

Job and Career Services
 Open to the Public

831-637-JOBS (Hollister)
www.sbcjobs.org

ROP Accounting

Payroll Accounting

Advisory: Eligible for Mathematics 205, completion of Accounting 101. An introduction to the calculating, journalizing, paying and reporting of employee earnings, employee withholding and employer payroll tax expenses. The course emphasizes procedures which conform to federal and state legal requirements. This course has the option of a letter grade or pass/no pass. For college credit, enroll in Gavilan's ACCT105.

Room	Instructor	Day	Time
HU103	Brown R	T	0630-0935

Spreadsheet - MS Excel

Advisory: CSIS 1 or CSIS 2 or equivalent computer experience. Introduction to the computer spreadsheet software. A hands-on approach to learning terms, commands, and applications of a spreadsheet program. This course will help prepare students for taking the Excel MOUS (Microsoft Office User Specialist) exams. This course has the option of a letter grade or pass/no pass. May be repeated once for credit when the software changes. For college credit, enroll in Gavilan's ACCT 121 or CSIS 121.

Room	Instructor	Day	Time
HOL3	Mendez F	W	0600-0905

09/30/09 - 12/09/09 Above class meets at the Hollister Briggs site.

ROP Administrative Medical Assisting

Medical Terminology for the Office

Advisory: Eligible for English 250 and English 260. This course introduces fundamentals of medical word building used in the health profession (prefixes, word roots, suffixes and abbreviations) as well as review of body systems, with emphasis on analysis, definition, spelling and pronunciation. This course had the option of a letter grade or pass/no pass. For college credit, enroll in Gavilan's BOT180.

Room	Instructor	Day	Time
MHG4	Knapp D	W	0300-0555

Above class meets at Morgan Hill Community site.

Medical Billing - MediSoft

Advisory: Eligible for English 250. Some computer experience. This course in computerized billing procedures for a medical office uses MediSoft software. Students will learn the patient billing features of this software and complete a capstone simulation giving them hands-on realistic medical front office practice. This course has the option of a letter grade or pass/no pass. May be repeated three times for credit. For college credit, enroll in Gavilan's BOT181.

Room	Instructor	Day	Time
PB3	Knapp D	M	0600-0905



Short-term Training Program ROP Dental Assisting

Includes Radiology (X-Ray) Certification

Location: ROP-South, 700 W. 6th St., Ste. L, Gilroy

Online Registration ONLY: August 18, 2009, 8:00 am*
<http://sccoe.org/depts/scrop/>

Class dates and times:
September 8 - January 29, 2009
Mon-Fri, 9:30 am - 3:00 pm

Cost: \$230** includes book and lab fee. Students must purchase lab coats.
** *Price subject to change*

This course includes instruction in chairside assisting as well as x-ray certification.

Call the ROP Main Office at
(408) 842-0361
for more information.

* Confirmation of enrollment will be sent to the first 25 students. (All other students will be put on a waiting list.)

ROP Administrative Medical Assisting cont.

Medical Coding

Advisory: BOT 180.

This course will introduce the student to the theory and procedure of coding for medical diagnoses, an increasingly essential and specialized healthcare communication system. The course is not a certification course. CPT coding is covered, with an overview of ICD-9 coding. This course has the option of a letter grade or pass/no pass. May be repeated three times for credit. For college credit, enroll in Gavilan's BOT183.

Room	Instructor	Day	Time
PB3	Knapp D	R	0600-0905

ROP Computer Applications

Word Processing - MS Word

Advisory: Eligible for English 260 and basic keyboarding skills.

This introductory course for word processing with Windows is designed for business and non-business majors. Students will develop word processing skills to create a document, select and edit text, move and copy text, use the spelling, grammar, and thesaurus features, format text, and create headers and footnotes for a research paper. This course has the option of a letter grade or pass/no pass and may be repeated for credit when the software changes. For college credit, enroll in Gavilan's CSIS 126.

Room	Instructor	Day	Time
HOL3	Mendez F	M	0600-0905

09/28/09 - 12/07/09 Above class meets at the Hollister Briggs site.

ROP Clinical Medical Assisting

Basic Clinical Medical Assisting

Prerequisite: Eligible for English 250, English 260 and Mathematics 205.

Course provides a basic introduction to clinical medical assisting. Emphasizes principles, understanding of skills necessary to perform basic clinical medical assisting procedures safely and effectively. For college credit, enroll in Gavilan's AH 170.

Room	Instructor	Day	Time
HOB114	Arballo C	TWR	1250-0420

ROP Nursing Assistant

Fundamentals of Nursing--Convalescent

Prerequisite: Eligible for English 250 and English 260. Clearance from the Department of Health Services (Form HS283), fingerprint card, and health clearance required prior to clinical placement. Health and fingerprint clearance required prior to clinical placement. Uniform, shoes, watch, and stethoscope required. Clinical in Morgan Hill or Hollister, as assigned.

A course to provide a basic introduction to patient care in the convalescent setting. Emphasizes principles, understanding and skills necessary to perform basic nursing procedures safely and effectively. Includes introduction to health care, planning, safety, infection control, personal care, basic procedures, rehabilitation, nutrition and clients' rights and needs. At the completion of this course students will qualify for state certification as a nursing assistant. For college credit, enroll in Gavilan's AH 180.

Room	Instructor	Day	Time
HOB114	Machado M	MT	0910-1200
HOB114	TBA	W	0630-0130

Room	Instructor	Day	Time
HOB114	Machado M	MT	0900-1200
HOB114	TBA	R	0630-0130

Additional ROP sites in the Gavilan College District

All day classes offered at high school locations are part of the regular high school schedule. Adults are admitted on a space-available basis by contacting the high schools.

ROP Instructional Services
Gilroy - 408-842-0361
 Dental Assisting

Ann Sobrato High School
408-201-6200
 Advanced Commercial Art
 Advanced Commercial Photography
 Advanced Multi-Media
 Agriculture Sales & Service
 Animation & Digital Design
 Athletic Training/Sports Medicine
 Biotechnology
 Environmental Horticulture
 Stagecraft
 Veterinary Science
 Visual Communications (Digital Media)
 Welding

Anzar High School
408-623-7660
 Audio Video Publishing
 Photography

Central Continuation High School
408-201-6300
 Computer Business Applications

Gilroy High School
408-847-2424
 Advanced Auto Technology
 Art & History of Floral Design
 C.A.D. Drafting
 Culinary Arts
 Commercial Photography
 Computer Bus. Applications
 Criminal Justice
 Digital Design and Animation I & II
 Marketing & Merchandising
 Sports Medicine I & II
 Veterinary Medicine
 Visual Communications

Live Oak High School
408-201-6129 or 408-201-6111
 Advanced Multi-Media
 Agriculture Sales & Services
 Cabinetmaking
 CISCO Applied Networking
 Construction Technology
 Developmental Psych of Children
 Environmental Horticulture
 Fashion Design
 Graphics Technology
 Veterinary Science
 Visual Communication (Digital Media)

San Andreas High School
831-637-9269
 Computer Bus. Applications

San Benito High School
831-637-5831, ext. 185
 Advanced Art AP
 Ag. Fabrication-Construction
 Audio Video Publishing
 Auto Mechanics
 Cabinet Making
 Careers w/Children
 Child Development/Vocational
 Commercial Art
 Computer Accounting
 Computer Aided Drafting/C.A.D.
 Computer Applications
 Computer Maintenance
 Computer Programming
 Floriculture
 Food Service/Restaurant Careers
 Marketing
 Metals Fabrication
 Sales Marketing
 Sports Medicine
 Technical Writing
 Wood Sculpture/Design

Check out

- Classes and services offered at the satellite sites...
 Hollister classes... page 60-61 Morgan Hill classes... page 62-63
- Late-Start Classes... page 57
- Online/Hybrid Classes... page 58-59

FINAL EXAM SCHEDULE

Sunday-Saturday, December 13-19, 2009

This schedule is designed to provide dates and two-hour blocks of time for Final Exams in credit courses. Final exams will begin Sunday, Dec. 13, 2009. Classes meeting prior to 8 a.m. will take their exams during the same week, for a two-hour period beginning at the class starting hour.

All finals are to be given at the scheduled time, and in the room in which the class has regularly met during the semester. Exceptions can be granted only by the department chair and the area dean.

If a class appears not to have a time scheduled according to the chart below, please see the instructor, department chair or area dean. Instructors' office hours will be changed to accommodate the final exam schedule. Please check your instructor's office for the revised schedule.

If your class meets on these days:

Daily, M, MTuW, MTuWF, MW, MWTh, MWThF, MWF, MTh, MThF, MF, W, WTh, WThF, WF

Starts at any time between:	Your final exam will be:
08:00 - 09:40	Wed. Dec 16 08:00 - 10:00
09:45 - 11:00	Mon. Dec 14 08:00 - 10:00
11:05 - 12:20	Wed. Dec 16 10:30 - 12:30
12:25 - 01:40	Mon. Dec 14 10:30 - 12:30
01:45 - 03:00	Wed. Dec 16 01:00 - 03:00
03:05 - 04:30	Mon. Dec 14 01:00 - 03:00

If your class meets on these days:

MTu, MTuWTh, MTuTh, MTuThF, MTuF, Tu, TuW, TWTh, TuWThF, TuWF, TuTh, TuThF, TuF, Th, ThF

Starts at any time between:	Your final exam will be:
8:00 - 9:10	Tues. Dec 15 08:00 - 10:00
9:15 - 10:25	Thur. Dec 17 08:00 - 10:00
10:30 - 11:40	Tues. Dec 15 10:30 - 12:30
11:45 - 12:55	Thur. Dec 17 10:30 - 12:30
1:00 - 2:10	Tues. Dec 15 01:00 - 03:00
2:15 - 3:25	Thur. Dec 17 01:00 - 03:00
3:30 - 4:55	Tues. Dec 15 03:30 - 05:30

Fri or Fri/Sat classes: If your class meets at ANY start time between 8-10:55 am, the final exam will be: Friday, Dec 18 from 8:00-10:00 am. If your class meets at ANY start time between 11:00 am - 1:55 pm, the final exam will be: Friday, Dec 18 from 10:30 am - 12:30 pm. If your Friday class meets at any start time between 2 pm - 4:55 pm, your final exam will be on Friday, Dec 18 from 1 pm - 3 pm.

Make-ups and Conflicts:	Mon. Dec 14	03:30 - 05:30
	Wed. Dec 16	03:30 - 05:30
	Thur. Dec 17	03:30 - 05:30

Exams for classes held on Saturdays, Sundays & Evenings

All classes held on:

Monday evenings	Mon. Dec 14
Tuesday evenings	Tues. Dec 15
Wednesday evenings	Wed. Dec 16
Thursday evenings	Thurs. Dec 17
Friday evenings	Fri. Dec 18
Monday/Wednesday evenings	Mon. Dec 14
Tuesday/Thursday evenings	Tues. Dec 15
Saturday	Sat. Dec 19
Sunday	Sun. Dec 13

ESL (English as a Second Language)

New students who want to take ESL classes at the Gilroy campus will register at the Admissions & Records Office for a placement assessment appointment when completing an application. Call 408-848-4737 or 408-848-4751 to make an appointment or come into Admissions & Records at the Gilroy main campus.

Students interested in taking ESL courses in Hollister should contact Judy Rodriguez at (831) 636-3783 or go to the Briggs Building in Hollister to schedule an assessment appointment.

Who Should Take the ESL Assessment?

- Students who do not know any English.
- Students who know some English but have not received formal classes in the English language or who took ESL classes more than three years ago.
- Students who attended high school in this country for less than a year.
- Students who attended high school in this country for a few years but are unsure about their level of proficiency in English.



Placement Assessment and Orientation for ESL Applicants

Students who want to enroll in ESL classes must:

- Complete a Gavilan College application at Admissions & Records or at the sites.
- Sign up for a testing appointment at Admissions & Records (Gilroy).
- Return for testing, which includes oral and written exams.

The interview information and the test results will be used to advise and place students into the ESL classes that best match their needs. Students will be ready to register for ESL classes at the end of this three-hour placement assessment appointment.

Orientation for new ESL students will be offered several times during the first two weeks of the semester and will be given in English and Spanish in the classroom setting. New students will be contacted for orientation by their ESL instructors.

Para información sobre clases de ESL, refiérase a la página 97.

Revise las clases 501 y 503 (cursos intensivos) y 527 ofrecidos en Hollister por la tarde. Refierase a la página 97-98.

Para información sobre clases de destrezas básicas, refiérase a las páginas 96-97 (ENGL 420, 439, 440) y página 110 (MATH 400, 402).

Nunca es tarde para obtener su GED (ENGL 756). Revise éste curso GRATIS en la página 56 (verano) y página 129 (otoño).

ESL (Inglés como Segundo Idioma)

Los nuevos estudiantes que deseen tomar clases de Inglés como Segundo Idioma (ESL) en Gilroy deben inscribirse en la Oficina de Admisiones y Archivos para hacer una cita y tomar la evaluación apropiada después de llenar una solicitud. Llame 408-848-4737 o 408-848-4751 hacer una cita o venga a la Oficina de Admisiones y Archivos en Gilroy.

Aquellos estudiantes que desean estudiar en Hollister deben hacer una cita para tomar el examen de nivelación en la oficina en Hollister en el Briggs Building o llamar al 831-636-3783.

¿Quién debería tomar el examen de evaluación de ESL?

- Los estudiantes que no saben nada de inglés.
- Los estudiantes que saben un poco de inglés pero que no han tomado clases formalmente o que tomaron clases hace más de tres años.
- Los estudiantes que asistieron a la secundaria (high school) en este país por menos de un año.
- Los estudiantes que asistieron a la secundaria (high school) en este país por algunos años pero que no están seguros de su nivel de proficiencia en el inglés.

Asesoramiento, Colocación y Orientación para Estudiantes ESL

Los estudiantes que deseen inscribirse en clases de ESL (Inglés como Segundo Idioma) deben hacer lo siguiente:

- Completar una solicitud de admisión en la Oficina de Admisiones y Archivos.
- Obtener una cita para el examen de nivelación en la Oficina de Admisiones y Archivos (Gilroy).
- Presentarse al examen de nivelación de acuerdo con la cita obtenida para tomar el examen escrito y oral.

Los resultados del examen y la información de la entrevista serán usados para recomendar y colocar a los estudiantes en las clases de Inglés como Segundo Idioma (ESL) que mejor les convengan. Los estudiantes estarán listos para inscribirse en las clases adecuadas al final de esta evaluación de tres horas. Los nuevos estudiantes en el Programa de Inglés como Segundo Idioma (ESL) recibirán una orientación sobre los servicios y regulaciones del Colegio Gavilán en sesiones ofrecidas durante las primeras dos semanas del semestre. Las orientaciones serán dadas en inglés y en español y los maestros se comunicarán con los nuevos estudiantes para asistirlos en seleccionar la sesión más conveniente.

¿Necesita ayuda para comprar libros?



Si usted ya compro su tarjeta de Cuerpo Asociado de Estudiantes (ASB) usted podrá aplicar para prestamos (maximo \$300) para comprar libros, en la Oficina de Ayuda Financiera, cuarto SC124.

Usted puede comprar la tarjeta de ASB en la Oficina de Admisiones y Archivos, cuarto SC 111.

Información en Español

Nuestra Misión

En un ambiente que cultiva la creatividad, estimula la curiosidad y hace énfasis en el aprendizaje del estudiante, Gavilán College sirve a su comunidad, ofreciendo servicios de gran calidad y apoyo, que preparan a los estudiantes para carreras de transferencia a la universidad o técnicas y de servicio público, educación para toda la vida y la participación en una sociedad global y diversa.

Polizas y Procedimientos

Pendiente a la Mesa Directiva. La Política y Procedimientos del Colegio están disponibles a través de acceder la página de Internet del Colegio Gavilan en www.gavilan.edu (Seleccione el "College Catalog" bajo el menú de "Academics") o visitando la Oficina del Vicepresidente de Servicios Estudiantiles (SC128).

Formas Alternativas El Catalogo y el Horario de Clases del Colegio Gavilán está disponible en formato de medios alternos.

Por favor de contactar El Centro de Recursos para Discapacitados (DRC) en (408) 848-4865 o la Oficina del Vicepresidente de Servicios de Estudiante en (408) 848-4738.

Servicios para los Estudiantes con Incapacidades

Los estudiantes que requieren servicios o arreglos especiales debido a incapacidades auditivas, visuales o alguna otra incapacidad verificado deberán ponerse en contacto con su instructor, consejero, asesor El Centro de Recursos para Discapacitados (DRC).

No Discriminación El Distrito está comprometido a proveer igualdad de oportunidades en programas educativos, empleo, y acceso a programas y actividades de la institución.

Prohibición de Abuso y Ofensas por Discriminación

Referencia: Secciones 212.5; 66252; 66281.5 del Código Educativo

El Distrito está comprometido a proveer un ambiente de enseñanza y de trabajo que respete la dignidad de los individuos y grupos. El Distrito estará libre de ofensa y persecución sexual y todas la formas de intimidación sexual y abuso. También estará libre de otros abusos y ofensas por discriminación incluyendo aquellas ofensas basadas en cualquiera de los siguientes estados: raza, religión, ancestro, origen, impendimiento, sexo (género), orientación sexual, o la percepción de que una persona tenga alguna de las características mencionadas.

Cumplimiento de ADA Si usted tiene un impedimento verificado y necesita materiales o servicios de estudio en un formato alterno, contacte El Centro de Recursos para Discapacitados (DRC) o al Vicepresidente de Servicios Educativos para obtener ayuda. Hay servicios para estudiantes con impedimentos verificados a través de DRC o a través del Vicepresidente de Servicios Educativos.

Derechos Educativos y Privacidad Gavilan College está en cumplimiento de los Derechos Educativos Federales y Acto de 1974 (también llamado el Buckley Amendment) y las regulaciones del Título V de California (SB 182). Las siguientes reglas están en efecto:

1. Toda la documentación académica, documentación relacionada con problemas disciplinarios, y cualquiera otra documentación oficial es mantenida para todos los estudiantes que han solicitado admisión a Gavilan College.
2. La documentación oficial es mantenida por y localizada en la Oficina de Admisiones y Registros.
3. La documentación oficial será proveida únicamente cuando la solicitud o permiso sea hecha por escrito por parte del estudiante previo pago de cualquier cargo o costo a la institución, excepto en los casos provistos en ley.
4. La siguiente información puede ser proveida por Gavilan College sin consentimiento escrito por parte del estudiante:
 - a. el nombre del estudiante
 - b. las fechas de matriculación/asistencia a Gavilan College
 - c. la fecha de graduación y título o certificado recibido

La entrega de cualquier otra información requerirá consentimiento escrito del estudiante, excepto en los casos provistos en ley. Los estudiantes pueden notificar su deseo por escrito a la Oficina de Admisiones y Registros durante la primera semana de cada sesión de estudios que no desean que los puntos enumerados en a), b) y c) pueden ser entregados.

5. Los estudiantes tienen derecho a revisar sus propios archivos y la documentación que esté en ellos. Cualquier objeción a éstos archivos debe ser presentada por escrito al Vicepresidente de Instrucción y Servicios al Estudiante. Las objeciones serán resueltas por dicho vicepresidente, y la resolución será inserta en el archivo del estudiante pero no entregada con el resto de la documentación. En caso de desacuerdo sobre éste punto, la Política de Quejas de la institución estará en efecto.

Copias de las regulaciones federales y estatales y del Proceso de Resolución de Problemas Estudiantiles son disponibles a través de la Oficina de Admisiones y Registros y pueden ser revisadas por los estudiantes haciendo una cita con el Vicepresidente de Instrucción y Servicios Estudiantiles o el Director de Admisiones y Registros. El Proceso de Resolución de Problemas Estudiantiles también está disponible en éste catálogo, online, y en el Manual Estudiantil.

Habilidad en Inglés para Estudios Vocacionales

Habilidad limitada en Inglés no será obstáculo para ser admitido y participante en programas educativos vocacionales.

Título VI, Título IX, y Norteamericanos con Impedimento/Sección 504/508

Para presentar una queja en cualquiera de las siguientes areas, por favor comuníquese con el Oficial de Igualdad de Oportunidades, Joseph D. Keeler, Vicepresidente de Servicios Administrativos, HR 101 (408-848-4731) o Shairon Williams, Director de Recursos Humanos, HR103 (408-848-4753).

Las areas son las siguientes: quejas por violación de derechos civiles (Título VI), quejas por violación de igualdad de género, discriminación sexual, o abuso (Título IX) y quejas por violación contra personas con impedimentos (ADA/Sección 504/508)

Programa de No-Credito

Clases de No-Crédito son ofrecidas y diseñadas para responder a las necesidades específicas e intereses de aquellos estudiantes que no desean obtener créditos por unidades. Estas clases ofrecen oportunidades para mejorar en materias, crecimiento del desarrollo, poder aprender ocupaciones y para aprender otras áreas de educación general. Estos cursos y programas están definidos categóricamente bajo el Código de Educación, Sección 84711, mientras que los fondos del estado se permiten en nueve categorías específicas.

Programa para Personas Mayores - Este programa ofrece clases de interés especial para adultos mayores de 55 años de edad. La mayoría de nuestras clases se llevarán a cabo en lugares de reuniones de adultos mayores con el fin de promover una inscripción satisfactoria y facilidad para dichos estudiantes.

Programa para el Bienestar del Personal - Este programa está diseñado para responder a las necesidades de los adultos que trabajan. Las clases están abiertas para todos los miembros del personal y de la comunidad.

Programa de Educación Básica Para Adultos - Este programa está diseñado para adultos que desean tomar clases de Inglés como Segundo Idioma (ESL). Ofrecemos clases para preparación de Ciudadanía, clases para mejorar sus habilidades en lectura, escritura, y matemáticas. El programa también ofrece clases para los estudiantes que están interesados en preparación de Educación General (GED) y CAHSEE (Examen de Egreso de las Preparatorias de California).

Todas las clases son gratuitas. No se requieren pruebas, exámenes ni tampoco se otorgan calificaciones. Las inscripciones se realizan a través de la Oficina de Admisiones y Archivos o en el lugar en donde se vaya a impartir la clase, durante la primera sesión de la clase. Los estudiantes deben de contactar directamente a la Oficina de No-Crédito si tienen preguntas o si necesitan más información, favor de llamar al (408) 852-2824.

Servicios Estudiantiles y Programas de Apoyo para la Instrucción

Servicios de Asesoría Inscribirse y tener éxito en clases a nivel post-secundario requieren dedicación y tiempo. A veces ocurren problemas personales y familiares que distraen a los estudiantes de sus tareas y clases y en estos casos, la única solución parece ser abandonar los estudios. Antes de tomar esta decisión tan difícil, por favor consulte a un consejero. Una buena plática puede ayudar a poner la situación en perspectiva, identificar posibles soluciones, y dar el apoyo necesario para hacer modificaciones necesarias en el horario y las clases. Gavilán College provee consejeros que hablan español y las citas con ellos pueden ser hechas para el día o para la tarde. No hay que pagar por este servicio. Por favor llame al 408-848-4723 para hacer una cita.

Centro de Desarrollo de Niños El Centro de Desarrollo de Niños provee cuidado para niños preescolares, en dos programas para familias con ingresos mensuales que satisfacen el criterio de elegibilidad. Estos programas sirven a niños con discapacidades y necesidades especiales y que no hablan inglés. Todos los programas requieren que los padres inviertan ciertas horas como voluntarios.

El Centro de Recursos para Discapacitados (DRC) ofrece asesoría individual para evaluar las destrezas de los estudiantes en las áreas de lectura, matemáticas, escritura, razonamiento, lenguaje oral, percepción y memoria. Los estudiantes que requieren servicios o arreglos especiales debido a incapacidades auditivas, visuales o alguna otra incapacidad deberán ponerse en contacto con su instructor, consejero, asesor o la oficina del DRC.

Servicios de Ayuda Económica para el Colegio

La ayuda económica para costos del colegio, están disponibles para estudiantes de cualquier tipo de ingreso.

OFICINA DE AYUDA ECONÓMICA

www.gavilan.edu/finaid/

Oficina SC 124

Abierto: lunes-jueves: 8 a.m. a 5 p.m., viernes: 8 a.m. a 3 p.m.

Horario de la Tarde: Las horas son extendidas de 5 a 7 pm durante el período de matriculación.

CÓDIGO ESCOLAR DEL COLEGIO GAVILÁN ES: 001202

El colegio Gavilán participa en varios programas de ayuda económica, que están diseñados para proporcionar ayuda a los estudiantes de necesidad económica. Esta ayuda es proporcionada por diferentes instituciones incluyendo agencias federales, estatales y privadas.

Si está interesado en solicitar ayuda económica, adquiera una solicitud (FAFSA) en la oficina SC 124 o solicítela usando el Internet en la página www.fafsa.ed.gov. Si llena la solicitud usando el Internet, imprima y mande la página con su firma (signature page) o use su número secreto (PIN) para firmar la solicitud electrónicamente. Si desea aplicar para obtener su número secreto (PIN) ingrese a www.PIN.ed.gov. Las solicitudes también se pueden obtener por medio de los Consejeros de las Preparatorias (High School), Centro de Carreras de la Preparatoria y Bibliotecas Públicas.

Los requisitos para ayuda económica de parte de FAFSA son:

- Tienen que comprobar que necesitan ayuda económica y que cumplen con las reglas de cada programa.
- Tienen que ser ciudadanos, o ser residentes permanentes de los EE.UU.
- Tienen que tener buen historial en préstamos estudiantiles, y no deber nada a la oficina de ayuda económica.
- Tienen que ser elegibles para recibir los beneficios de una educación superior.
- Hombres entre 18 y 25 años de edad tienen que registrarse en el servicio selectivo (militar).

NOTA: Si ha estado encarcelado por usar o vender drogas ilegales, puede ser no elegible para algunos programas de ayuda económica.

PÓLIZA DE PROGRESO SATISFACTORIO ACADÉMICO (SAP)

La oficina de ayuda económica requiere medir su progreso académico hacia un certificado, asociado, o un programa de transferencia a la universidad. Si sus metas no son uno de estos programas, no califica para ayuda económica. Su progreso será evaluado por lo mínimo una vez por año.

Si ustedes han tenido circunstancias extenuantes durante su último término en el Colegio Gavilán y fueron colocados en descalificación, podrán someter una Apelación y un Cuestionario SAP para su consideración.

PROGRAMAS DE AYUDA ECONÓMICA

Ayuda Pagando la Matriculación: El programa (Board of Governor's Fee Waiver/BOG), ayuda a pagar parte de la matriculación. Solamente para residentes de California. Es para estudiantes de bajo ingreso familiar. La solicitud para el BOG se encuentra en la página de Internet en: www.gavilan.edu/finaid/

Becas Gratuitas Federales y Estatales:

- Federal Pell Grant
- Federal SEO Grant
- Federal Work Study Grant
- Cal Grant
- CARE Grant
- Chafee Grant
- Child Development Grant
- EOPS Grant
- TRIO Grant

Becas Federales de Trabajo y Estudio: Proporcionan a los estudiantes de Gavilan Collage empleos temporales mientras obtienen valiosa experiencia laboral. Para ser considerados para el programa de trabajo y estudio federal, se requiere que los estudiantes llenen la solicitud de FAFSA 2009-2010 FAFSA, que indiquen que están interesados en el Programa de Trabajo y Estudio en la pregunta 31 de FAFSA, que alcancen los requisitos del programa y que reciban ayuda financiera. Puesto que los fondos para el programa Federal de Trabajo y Estudio son limitados, se sugiere que los estudiantes sometan su solicitud FAFSA 2009-10. FAFSA antes del 05/15/2009 para ser considerados para FWS. Las primeras becas FWS serán ofrecidas a los estudiantes elegibles en 06/30/2009.

Becas: Las becas son otorgadas en base al aprovechamiento académica y/o la necesidad financiera. La elegibilidad varía y se establece dependiendo del donador de dicha beca. Las solicitudes para becas privadas las encuentran durante el año en la página de Internet de Ayuda Financiera en www.gavilan.edu/finaid. Les recomendamos que busquen becas en línea varias veces durante el semestre. Durante el ciclo escolar se anuncian becas en cuanto están disponibles.

Servicios Para Miembros de las Fuerzas Armadas (Veteranos): Colegio Gavilán ofrece asistencia especial a estudiantes que son veteranos o hijos de veteranos deshabilitados que asisten al colegio, para lograr una meta. Estudiantes que tengan preguntas sobre si califican, beneficios y el procedimiento de las solicitudes o cualquier otra inquietud sobre veteranos, por favor de contactar la oficina de ayuda económica al 408-848-4734.

Préstamos Estudiantiles Federales: Colegio Gavilán participa en el Federal Family Educational Loan Program. Préstamos estudiantiles federales, ofrecen un interés bajo y planes de pago flexibles. Si están interesados en solicitar un préstamo complete la FAFSA y atienda al taller de consejería de préstamo. Solicitudes para el préstamo serán distribuidas en el taller de consejería.

Becas Privadas: Becas privadas son fundadas por organizaciones y agencias privadas. Estos fondos se otorgan al estudiante dependiendo de las notas académicas o dependiendo de la necesidad económica del estudiante. Para ser considerado para una beca privada, el estudiante necesita completar una solicitud por cada beca privada a la que se aplique. Visite nuestra oficina para mas información.

Solicitudes para la beca privada llamada "Gavilan College Scholarship Application" estan disponibles en nuestra oficina.

VISÍTENOS EN LA PÁGINA DEL INTERNET A WWW.GAVILAN.EDU/FINAID

Complete la FAFSA en la página del Internet WWW.FAFSA.ED.GOV

Ayuda de planeamiento financiero y consejería de préstamos en la página WWW.EDWISE.ORG

Averigüe su estado de préstamo en la página WWW.ELMRESOURCES.COM

Regístrate para Servicios Selectivos en la página WWW.SSS.GOV

Aplique para su número de identificación personal (PIN) en la página WWW.PIN.ED.GOV

El Centro de Desarrollo Infantil del Colegio Gavilán

provee cuidado de niños hasta la edad de cinco años mientras que usted asiste a sus clases.

(408) 848-4815

Acreditado por NAEYC

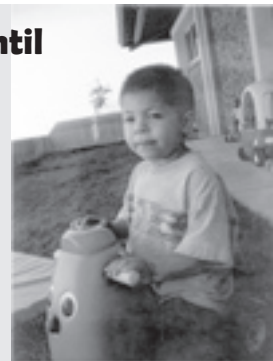
**EOPS**

Programas y Servicios de Oportunidad Adicional

La oficina de Programas y Servicios de Oportunidad Adicional (EOPS) provee apoyo a estudiantes que experimentan desafíos económicos, sociales, y educativos. La intención del programa es asistir a estos estudiantes a alcanzar sus metas educativas incrementando el acceso, la retención, y la transferencia a otras instituciones de enseñanza. Para calificar para el programa de EOPS, los estudiantes deben demostrar necesidad financiera y educativa y matricularse en un mínimo de 12 unidades cada semestre.

Servicios y beneficios disponibles para estudiantes: Conserjería personal y académica, asistencia para la compra libros, prioridad de inscripción a clases, tutoría, paseos a universidades, talleres de enriquecimiento, becas y mucho mas.

**CalWORKs**

CalWORKs sirve a estudiantes quienes reciben asistencia pública para llegar a ser autosuficientes, a través ofrecerles educación, empleo y servicios de apoyo. Los programas laborales para los estudiantes de Cal-WORKs, están vinculados a las demandas del mercado laboral y pueden ayudarlos a trabajar en una trayectoria de carrera que los lleve a obtener un ingreso suficiente para poder sostener a sus familias. Los servicios de apoyo que CalWORKs ofrece incluyen el área académica, la personal y asesoría para la carrera, libros de texto, asistencia y colocación de empleo, servicios de apoyo y enlace con los departamentos de servicios sociales del condado

El personal de CalWORKs es cordial y apoya a los estudiantes para que estos puedan lograr alcanzar sus metas. La oficina se encuentra localizada en L101 A, junto a la biblioteca y está abierta de lunes a viernes de 8 a.m. a 5 p.m. Los estudiantes interesados pueden llamar al 408-848-4740.



~ Program is for 1st time college freshmen ONLY ~

APPLICATION - Fall 2009

Name: _____ Gavilan ID #: G00 _____
 Address: _____ Phone: (_____) _____ - _____
 City: _____ Cell Phone: _____
 Zip Code: _____ Email: _____

*** Attach your high school transcript (must include senior year coursework.) ***

I would like to transfer to: _____ California State University _____ University of California
 _____ Private College/University _____ Not sure which system

Are you working while attending college? _____ Yes (# of hours per week _____) _____ No

Are you eligible for financial aid? _____ Yes _____ No _____ Don't Know

High School Graduate? _____ Yes _____ No _____ GED Year Graduated: _____

~ Program is for 1st time college freshmen ONLY ~

Name of High School: _____ City: _____ State: _____
 Major: _____ Currently Undecided: _____

Please describe why you want to be part of the Transfer Institute: _____

For office use only	College Level: English 1A and Transfer Level Math:
Placement/Assessment Scores: _____ Reading	_____ Writing _____ Math

Intent to Register:

I agree to make a full commitment to the Transfer Institute. This commitment includes the following:

- Sign a Transfer Institute agreement by **September, 2009**.
- Meet with a counselor three times per semester.
- Participate in Transfer Institute activities.

Student Signature: _____ Date: _____



IMPORTANT, PLEASE RETURN TO:
Gavilan College Counseling Department
5055 Santa Teresa Blvd.
Gilroy, CA 95020

Schedule Worksheet

Study Program

	<i>Monday</i>	<i>Tuesday</i>	<i>Wednesday</i>	<i>Thursday</i>	<i>Friday</i>	<i>Sat/Sun</i>
7:00 - 8:00						
8:00 - 9:00						
9:00 - 10:00						
10:00 - 11:00						
11:00 - 12:00						
12:00 - 1:00						
1:00 - 2:00						
2:00 - 3:00						
3:00 - 4:00						
4:00 - 5:00						
5:00 - 6:00						
6:00 - 7:00						
7:00 - 8:00						
8:00 - 9:00						

Use this worksheet to plan your schedule for the semester. For each day a class meets, list the course number and shade in the appropriate time slots. If a class extends beyond the hour, shade in the time slot to the nearest half hour. Gavilan College assumes no responsibility to adjust time conflicts which are the result of student errors.

Complete esta prueba de programa de estudios. Examinela para conflictos. Esta prueba de programa de estudios se ofrece para la conveniencia del alumno. Para cada día que una clase se reuna, apunte el número de la asignatura y llene las áreas del horario apropiadas. Si una clase se extiende más allá de una hora, llene la área próxima hasta la media hora siguiente. Es la responsabilidad del alumno evitar conflictos de horario. Gavilán College no será responsable de ajustar conflictos de horario que resulten por errores del alumno.

1 NAME
 (As you wish it to appear on your records) _____
Last Name First Name Middle Name

Gavilan ID # **G00**

Current Mailing Address _____
Street City

State _____ Zip _____ E-mail Address _____

Primary Phone # _____ Name on Previous Gavilan Records: _____

Alternate Phone # _____

2 GENDER Male ___ Female ___

3 BIRTHDATE _____
Month Day Year

PLACE OF BIRTH _____
State or Country

4 CITIZENSHIP

- U.S. Citizen
- Permanent Resident: INS Number _____ Date Issued _____
- Temporary Resident: INS Number _____ Date Issued _____
- Refugee/Asylee (verification required)
- F-1 Student Visa _____ Enter Appropriate Number in Box
- Other (specify) _____

5 MARITAL STATUS

Unmarried _____
 Married _____
 Decline to State _____

6 PREDOMINANT ETHNIC BACKGROUND

B. African-American, Non-Hispanic	AJ Japanese	PS Samoan
N. American Indian, Alaskan Native	AK Korean	HS South American
AI Asian Islander	AL Laotian	AV Vietnamese
AM Cambodian	HM Mexican, Mexican American, Chicano	W. White, Non-Hispanic
HR Central American	AC Other Asian	XD Decline to State
AC Chinese	HX Other Hispanic	<small>Enter Appropriate Code in Box</small>
F. Filipino	O. Other Non-White	<input type="text"/>
PG Guanamian	PX Other Pacific Islander	<input type="text"/>
PH Hawaiian		

7 STUDENT TYPE

- NEW, never attended any college
- NEW TRANSFER, attended college other than Gavilan
- RETURNING, last attended Gavilan but not last semester. Date of last attendance at Gavilan: _____

Semester _____ Enter Appropriate Number in Box

Year _____

8 EDUCATIONAL GOALS

1 Personal Interest, not for employment	8 Job Skills, to Prepare for a New Job/Career	<small>Enter Appropriate Number in Box</small>
2 Transfer to a 4-year College WITH AA, AS Degree	9 Enhance Present Job Skills	<input type="text"/>
3 Transfer to a 4-year College WITHOUT AA, AS Degree	10 Maintain Certificate or License (e.g., Nursing)	
4 Associate Degree, General Education	11 Improve Basic Skills in English, Reading, or Math	
5 Associate Degree, Vocational	12 Complete Credits for High School Diploma or GED	
6 Vocational Certificate	13 Undecided on Goal	
7 Discover/Formulate Career Interests, Plans, Goals		

9 STUDENT EDUCATION LEVEL (Highest level of education)

1 Not a graduate of, and no longer in high school	7 Foreign High School Graduate	<small>Enter Appropriate Number in Box</small>
2 High school student (currently enrolled in grades 9-12)	8 Received an Associate Degree	<input type="text"/>
3 Currently Enrolled in Adult School	9 Received a Baccalaureate or Higher Degree **	
4 Received High School Diploma *	* Year of High School Diploma <input type="text"/>	**Year Degree Conferred <input type="text"/>
5 Received GED or Certificate of Equivalency/Completion		
6 Received Certificate or High School Proficiency Exam		

10 HIGH SCHOOL LAST ATTENDED

___ 433395 Live Oak	___ 353650 San Benito Evening	___ 433363 Lick (James)	___ 273455 Salinas
___ 433448 Central	___ 353002 San Andreas Contin.	___ 273317 North Salinas	___ 433002 Sta Teresa
___ 433061 El Portal	___ 353006 Anzar	___ 274405 Notre Dame (Salinas)	___ 433790 Silver Creek
___ 433283 Gilroy	___ 433008 Gunderson	___ 433520 Oak Grove	___ 443790 Watsonville
___ 433485 Mt. Madonna	___ 433299 Hill (Andrew)	___ 433542 Overfelt	___ 433895 Willow Glen
___ 353700 San Benito	___ 433352 Leland	___ 274413 Palma	___ 010236 Ann Sobrato

Name & Location of High School if Not Listed Above _____
name city state

11 MAJOR Major _____ AA ___ AS ___ Certificate ___

12 DIRECTORY INFORMATION
 No personal data other than directory information will be released without your written consent.

13 COLLEGES ATTENDED (List last college attended first)

College: _____ Dates: from _____ to _____
City State

College: _____ Dates: from _____ to _____
City State



STATEMENT OF LEGAL RESIDENCE

Name _____ Gavilan ID# _____
Last First Middle Initial

Address _____
Street

City State Zip Date of Birth _____

PART A To Be Completed By All Applicants

Have you lived in California for the past two years?

Yes _____ If you answered "Yes" and you are unmarried and under the age of 19, go to **Part B**, otherwise, skip to Part D.

No _____ If you answered "No", complete the following:

- Date present stay in California began _____
- Do you intend California to be your permanent residence? Yes ___ No ___
- Did you file California State Income Tax for the last two years? Yes ___ No ___
- Are you a public school credentialed employee? Yes ___ No ___
- Are you a seasonal agricultural employee or dependent? Yes ___ No ___

• Drivers License or ID Card? State: _____ Date Issued: _____

• Registered to Vote? State: _____ Date Registered: _____

• Vehicle Registration? State: _____ Date Issued: _____

• Other Proof of Residency in California _____

• List states lived in for the last two years and the dates:
State: _____ from _____ to _____

State: _____ from _____ to _____

PART B To Be Completed About Your Parents or Legal Guardian If You Are UNMARRIED and UNDER the AGE OF 19

I have lived continuously for the past two years with one or both of my parents and he/she/they have lived continuously for the past two years at the California address noted below:

Street _____ City _____ State _____

Yes _____ If "Yes", Check one: Both Parents _____ Mother _____ Father _____ Legal Guardian _____

No _____ If "No" and you wish to be considered a California resident, please complete the following about your parent(s) or legal guardian:

- Did they file California State Income Tax the last two years? Yes ___ No ___
- Do(es) he/she/they have any of the following?
- Driver's License or ID card State: _____ Date Issued: _____
- Vehicle Registration? State: _____ Date Issued: _____
- Voter Registration? State: _____ Date Registered: _____
- Other Proof of Residency in California _____

PART C To Be Completed by Active Military Persons, Dependents, or Veterans Discharged Within the Last Year

- Are you a member of the military? Yes ___ No ___
- Are you a dependent of an active military person? Yes ___ No ___
- When did your or your sponsor's tour begin in California? _____
- What is your state of legal residence on military records? _____

Note:

Active duty military persons and/or dependents must provide a statement from the commanding officer stating the date of assignment and that the assignment to California is not for educational purposes. Dependents must also provide a letter stating that they are the dependent of a military person for the purposes of Federal Tax exemption.

PART D To Be Signed by All Applicants

I declare under penalty of perjury that the statements submitted by me in connection with this application and for determination of residency are true and correct. All materials submitted by me for purposes of admission become the property of Gavilan College. I understand that falsification, withholding pertinent data, or failure to report changes in residence may result in my dismissal from the College.

Student's Signature _____

Date _____

4/09-A&R



Program and Majors Codes

Administration of Justice

Law Enforcement
Academy
Corrections

Allied Health

Registered Nursing
Vocational Nursing

Business

Accounting
Economics
General Business
General Office
Marketing/Management
Medical Office
Real Estate

Child Development & Education

Child Development & Education
Pre K-12 Special Ed Aide

Communication

Communications, General
Communication Studies

Computer Graphics & Design

Computer Graphics & Design

Computer Science & Info Systems

Business Computer Applications
Computer Programming
Hardware & Networking
Programming for the Internet
Comp Prep for Bioinformatics
Telecom Network Cabling
UNIX Operating System
Web Page Production

Fine and Performing Arts

Art, General
Fine Arts
Music, General
Theatre Arts
Technical Theatre
Television

General Educaiton Pattern

CSU - General Ed
IGETC - General Ed Transfer

Letters

English as a 2nd Language
Language Arts

Liberal Arts - A.A. Degree

Areas of Emphasis Include:
Administration of Justice
Business
Computer Science & Info Systems

Elementary Education
Expressive Arts
Language Arts & Humanities
Natural Science
Social Science

Media Arts

Digital Media
Media Arts

Sciences

Biological Science
Physical Science & Engineering
Mathematics
Physical Education
Education/Sports Medicine
Health Science

Social Sciences

Social Science, General

Spanish

Spanish

Technical Trades

Aviation Maintenance
Airframe
Powerplant
Cosmetology/Esthetician
Industrial Technology
Special Careers

Gavilan College

Office of Admissions and Records
5055 Santa Teresa Blvd Gilroy CA 95020
www.gavilan.edu
408 848 4735
fax 408 846 4940

Educational Support Services for Students with Disabilities

If you would like to be contacted regarding supportive services complete this form and return it to the Disability Resource Center or the Admissions and Records Office at Gavilan College. For more information on available services, contact the Disability Resource Center at 408 848 4865.

Name _____
Last First Middle

Address _____
Street City State Zip Code

Phone _____

Check any of the following that currently apply:

<input type="checkbox"/> Deaf or	<input type="checkbox"/> Acquired	<input type="checkbox"/> Low Vision	<input type="checkbox"/> Developmentally	<input type="checkbox"/> Learning
<input type="checkbox"/> Hard of	<input type="checkbox"/> Injury	<input type="checkbox"/> or Blind	<input type="checkbox"/> Delayed Learner	<input type="checkbox"/> Disability
<input type="checkbox"/> Hearing	<input type="checkbox"/> Other	<input type="checkbox"/> Psychological	<input type="checkbox"/> Mobility	<input type="checkbox"/> Other
	<input type="checkbox"/> Physical	<input type="checkbox"/> Impairment		

• Gavilan College /High School Contract Form •

PLEASE READ CAREFULLY BEFORE PROCEEDING

- Gavilan College accepts high school students whose cumulative grade point average is at least 2.00 for advanced (transfer level courses numbered 1 - 99), vocational, and physical education courses for the Fall and Spring semesters. High school students may enroll for non-transferable courses (numbered 100-499) only during the summer session.
- A Gavilan application, placement assessment scores and current transcripts from the student's school are required before this form can be reviewed by a Gavilan counselor.
- Students may enroll for a maximum of six units for fall and spring

- semester, four units for summer.
- All course prerequisites are applicable.
- All credit earned at Gavilan College is "college" credit.
- A transcript of work completed at Gavilan will be sent to the recommending school at the end of the semester.
- High School contract students pay the per unit fee and provide their own texts and instructional supplies.
- All students shall conform to the college's academic rules, regulations, and codes of conduct.

Student's Name _____ Gavilan ID Number G00 _____
Last First M.I.

Mailing Address _____
Street City State zip

Tel. # _____ Date of Birth _____ Last Grade Completed _____

Semester for which student is applying: Fall _____ Spring _____ Summer _____ 20 _____

• The Student's School Counselor/ Designated School Official Recommends These Courses •

Specify recommended courses and units (Enrollment limited to courses numbered 1 - 99 except during the summer)

• Recommendations (Parent/Guardian, High School Official and Gavilan Counselor) •

1) Signature of Parent or Guardian _____ Date _____
Name Tel. #

In an emergency, contact _____

2) Name and Address of School _____

3) Name and Signature of Recommending School Official

NAME (please print) _____ SIGNATURE _____ Date _____

The recommendation of the school official signifies that the student is in good standing at his/her school, has a cumulative grade point average of at least 2.00, is eligible for continued enrollment, and has the ability and maturity to benefit from college-level instruction. **A current transcript of the student's coursework must accompany this form.**

2a) District Verification of "Home School" registration _____

4) The signature of the Gavilan Counselor verifies the following:

- The placement assessment was completed on (date) _____
- English Score _____ Math Score _____ DRC exemption? _____
- The recommended course is numbered 1 - 99 (summer term exempted)
- A current transcript from the student's school is attached and the student is in good standing.
- The cumulative high school grade point average is _____ (2.0 minimum required)

Gavilan College Counselor _____ Date _____

Telephone Numbers

Main Campus/Numero Principal	408-848-4800	Evening Office/Oficina Nocturna	408-852-2814
from Hollister, call toll free/desde Hollister llame gratis al	637-1158	Financial Aid/Ayuda Financiera	408-848-4727
Morgan Hill Site/Campus Morgan Hill	408-782-2873	First Year Experience/Experiencia del Primer Año	408-848-4723
Hollister Site, Briggs Building/Campus Hollister, Edificio Briggs	831-636-3783	Foundation/Fundraising/Fundación/Recaudaciones de Fondos	408-846-4936
Campus Security (non-emergency)/Seguridad del Campus (no emergencias)	408-848-4703	GavTV, Channel 18/Canal 18	408-848-4764
Emergency: First: Dial '911' (On campus, dial '8' first.)/Emergencias: Primero marque el 911. (desde el Campus marque primero el "8")		The Gavilan Press/Periódico "The Gavilan Press"	408-848-4837
Second: Dial '10' for campus emergency support./Segundo: Marque el '10' para apoyo de emergencias en el campus.		to fax news events/fax para enviar eventos noticiosos	408-848-4827
From campus pay phone: Dial 408-710-7490./Desde un teléfono público del campus: marque 408-710-7490.		GECA - TJ Owens Early College Academy/Academia de Universidad Temprana GECA TJ Owens	408-846-4909
Cell phone: 408-710-7490/Celular: 408-710-7490		Health Services/Servicios de Salud	408-848-4791
		HOPE Services/Servicios HOPE	408-846-6946
		Human Resources/Recursos Humanos	408 848 4755
		Instructional Services, Vice President's Office/Servicios de Instrucción/Oficina del Vicepresidente	408-848-4761
		International Students/Estudios Internacionales	408-848-4754
		Liberal Arts & Sciences, Dean's Office/Oficina del Decano en Ciencias y Humanidades	408-848-4701
		Library/Biblioteca	408-848-4810 or 408-848-4806
		Math Lab/Laboratorio de Matemáticas	408-846-4959
		MESA Program - Math, Engineering, Science Achievement/El Programa de Superación en Matemáticas, Ingeniería y Ciencias	408-846-4968
		Noncredit Program (Community Development)/Programa sin Créditos (Desarrollo en la Comunidad)	408-852-2824
		Placement/Assessment Testing/Exámen de Colocación-Evaluación Sign up/Registrarse	408-846-4992 408-846-4954
		Online/Telecourses/Cursos por Internet/Televisados	408 848-4885
		Outreach & Recruitment/Tours/Oficina de Inscripciones/Visitas al Campus	408-846-4993
		President's Office/Oficina del Presidente	408-848-4711
		Public Information Office/Oficina de Información Pública	408-848-4724
		Puente Program/Programa "Puente"	408-848-4807
		Reading Lab/Laboratorio de Lectura	408-846-4980
		R.O.P. - Regional Occupational Programs/Programas Regionales Laborales	408-848-4816
		STAR-Summer Theatre Arts Repertory/Repertorio de Artes Teatrales de Verano	408-848-4717 or 408-612-2057
		Student Services, Vice President's Office/Servicios Estudiantiles, Oficina del Vice Presidente	408-848-4738
		Technical and Public Services, Dean's Office/Servicios Técnicos y Públicos, Oficina del Decano	408-848-4719
		Theatre Arts Box Office/Taquilla del Teatro	408-846-4973
		Transfer (Career/Transfer Resource Center)/Transferencias (Centro de Recursos para Transferencias y Carreras)	408-848-4818
		Transfer Institute/Instituto de Transferencias	408-848-4723
		TRIO Student Support Services/Servicios de Apoyo Estudiantil TRIO	408-846-4981
		TTY (for Deaf or Hard of Hearing)/TTY (para Discapacitados Auditivos)	408-846-4924
		Tutoring Center/Centro de Tutoría	408-848-4838
		Veterans' Services/Servicios a los Veteranos	408-848-4734
		Work Experience/Experiencia de Trabajo	408-846-4993
		Writing Center/Centro de Escritura	408-848-4811
Admissions & Records/Oficina de Admisiones y Ré cords	408-848-4735 or 846-4954		
Student Accounts Cashier/Cajero de las Cuentas del Estudiante	408-852-2840		
transcripts/Expedientes Académicos	408-848 4733		
grading/calificaciones	408-848 4751		
applications/solicitudes	408-848 4736		
graduation/graduación	408-848 4737		
Allied Health/Aliado en la Salud	408-848-4883		
ASB Advisor/Asesor ASB	408-852-2849		
ASB Office/Oficina de ASB	408-848-4777		
Assessment Office/Oficina de Evaluaciones	408-846-4992		
Athletics/Physical Education/Deportes, Educación Física	408-848-4876		
Aviation/La Escuela del Aire	831-637-1151		
Basic Skills/Habilidades Básicas	408-848-4820		
Bookstore/Librería	408-848-4742		
Business Skills Center/Centro de Conocimientos Comerciales	408-848-4786		
CalWORKs/Programa de Experiencia de Trabajo en el área que se requiera	408-848-4813		
CARE - Cooperative Agencies Resources for Education/Agencias Cooperativas para Recursos de Educación	408-848-4790		
Career/Transfer Resource Center/Centro de Recursos para Carreras y Transferencias	408-848-4818		
Carpenter Training Center Apprenticeship Program/Centro de Entrenamiento en Carpintería, Aprendizaje	408-852-2815		
Cashier/Cajero	408-848-4714		
Child Development Center/Centro de Desarrollo Infantil	408-848-4815		
CMAP - Community Media Access Partnership/Sociedad de Medios Informativos para Acceso a la Comunidad	408-846-4983		
Community/Contract Education/Educación en la Comunidad/Contrato	408-852-2801		
Computer Graphics & Design (CGD) Lab/Estudio CGD	408-848-4868		
Computer Place/Lugar de las Computadoras	408-848-4729		
Cooperative Work Experience/Cooperativa de Experiencias de Trabajo	408-848-4813		
Cosmetology Appointment line/Cosmetología/Teléfono para Citas	408-842-5055		
Counseling Office/Oficina de Asesoría	408-848-4723		
Digital Media (Studio DM) - CGD lab/Centro Digital de Medios informativos (Estudio DM) - Lab CGD	408 848-4800, ext. 5604		
DRC - Disability Resource Center/Centro de Recursos para Discapacitados DRC	408-848-4865		
Discrimination-Harassment Complaints/Oficina de Quejas por Discriminación y Acoso	408-848-4731		
Distance Education Coordinator/Coordinador de Educación a Distancia	408 848-4885		
EOPS - Extended Opportunity Programs & Services/Programas y Servicios de Oportunidad Adicional	408-848-4740		
ESL Computer Lab/Laboratorio de Computadoras para ESL	408-848-4856		

Schedule Development Team

Rosie Armstrong, Mimi Arvizu, Sherrean Carr, Jan Bernstein Chargin, Michele Cortes, Katie Day, Bonnie Donovan, Fran Lopez, Michelle Lopez, Fran Lozano, Terri Newman, Jesus Olivas, Joy Parker, Rachel Perez, Dave Phillips, John Pruitt, Diane Stone, Cindy Starr

Cover photos by: Jan Bernstein-Chargin
 Photos by: Jan Bernstein Chargin, Pablo Balancio, Norm Haughey, Kimberly Smith
 Cindy Starr, The Gilroy Dispatch
 Printed by: Folger Graphics

MAIN CAMPUS, GILROY

5055 Santa Teresa Blvd.
 Gilroy, CA 95020
 408-848-4800 or
 831-637-1158 (from Hollister)

Building Guide

- AL Art Lecture
- APE Adapted Physical Education
- AR Art
- BOB Business Office Building
- BU Business
- CD Child Development
- CE Community Education
- CH Chemistry
- CHP Chapel
- CJ Classrooms, Community Ed.
- COS Cosmetology
- GY Gym
- HOB Health Occupations Bldg.
- HR Human Resources
- HRC Human Resources Conference Center
- HU Humanities
- LI Library
- LS Life Science
- M Maintenance
- MA Mathematics
- MAY Mayock House
- MP Multipurpose Building
- MU Music Hall
- OE Classrooms, Security
- PB Portable Buildings
- PH Physical Science
- SC Student Center/Administration
- SS Social Science
- TH Theater

-  Construction Zones
-  Bicycle Racks

Parking Lots

- A Student/Staff/Disabled Access/30 min. spaces
- B Student/Staff/Disabled Access/Visitor/30 min. spaces
- C Student/Staff/Disabled Access/15 min. spaces/30 min. spaces
- D Staff/Disabled Access
- E Student/Staff/Motorcycle
- F Staff/Disabled Access/Visitor/Motorcycle/30 min. spaces
- G Staff/Disabled Access
- H Student/Staff/Disabled Access/Motorcycle/30 min. spaces

Key to Gavilan

- Administration SC
- Admissions & Records SC
- Art Gallery LI
- ASB SC
- Assessment Center BU
- Athletics Office GY
- Basic Skills Network LI
- Bookstore SC
- Business Office BOB
- Cafeteria SC
- CalWORKs LI
- Career/Transfer Resource Ctr SC
- Cashier BOB
- Cashier (Student Accounts) SC
- Child Development Center CD
- Children's Infant Care CD
- Children's Preschool CD
- CMAP LI135
- Community Ed CJ/CE
- Computer Graphics & Design LI
- Computer Place LI168
- Counseling Offices SC
- Disability Resource Center LI
- Early College Academy PB16-18
- English/ESL PB12-13
- EOPS/Special Services LI
- Financial Aid Office SC
- Lounges, North and South SC
- Maintenance M
- Math Lab PH/MA101
- MESA PH/MA115
- Music (fall) MU
- Music TH
- Noncredit Program PB2
- Nursing HOB
- Payroll BOB
- Physical Education GY
- Police Academy OE/MP
- Public Information Office PB2
- Researcher CH/PH104
- ROP BU
- Security OE/MP
- Staff Resource Center PB11N
- Student Health Nurse SC
- Student Senate Office SC
- TRIO Program LI109
- Tutoring Center Services LI
- TV Studio LI

DON'T GO TO THE WRONG CITY!
 MHG = Morgan Hill
 HOL = Hollister

