

CRN Type Room Instructor Units Days Times Dates

ENGR 3 Electric Circuit Analysis

Transferable: CSU, UC; CAN:ENGR12

An introduction to the theory of electric circuits. Topics include resistive circuits, voltage and current sources, network theorems, op-amp circuits, energy storage elements, RC, RL, and RLC circuits. **PREREQUISITE:** Mathematics 2C (may be taken concurrently) and Physics 4B with a grade of 'C' or better.

40566	L/L	PS102	R Lee	4.0	TR	0600- 0905
-------	-----	-------	-------	-----	----	------------

ENGLISH

ENGL 1A Composition

Transferable: CSU, UC; CSU-GE:A2, IGETC:1A; GAV-GE:A2; CAN:ENGL2, ENGL SEQ A

This is a writing course which emphasizes expository writing, argumentative writing, and critical reading of expository prose. It is meant to train students in clear thinking and reasoned support of ideas. Students will be given the opportunity to read models of good expository and argumentative prose and learn the techniques of good writing. These include choosing appropriate subjects, developing restricted, unified, and precise theses and presenting supporting evidence in a logical, lucid, and effective manner. To achieve this end, students write no fewer than six essays and read at least five works, two of which are book length. **PREREQUISITE:** English 250 and English 260 or English 250 and SSCI 270A or English 250 and SSCI 270B with a grade of 'C' or better or satisfactory score on the English placement examination.

40387	Online		C Chaffin	3.0		
3 40388	Lec	HU103	M Fuzie	3.0	MW	0945- 1105
15 40389	Lec	HU102	T Mack	3.0	TR	0810- 0930
40390	Lec	MHG12	M Bragger	3.0	MW	0810- 0930
Above class meets at Morgan Hill Community site.						
40391	Lec	HOL2	G Mora	3.0	F	0900- 1205
Above class meets at the Hollister Briggs site.						
2 40392	Lec	HOL5	C Salvin	3.0	TR	1120- 1240
Above class meets at the Hollister Briggs site.						
40393	Online		E Crook	3.0		
40394	Lec	HU103	D Condon	3.0	TR	0945- 1105
2 40395	Lec	MA102	C Salvin	3.0	MW	1120- 1240
1 40396	Lec	HU102	S Sandler	3.0	TR	1120- 1240
This class is part of the PUENTE Program. If you enroll you must also enroll in GUID 1 #40352.						
4 40397	Lec	HU102	J Roscher	3.0	TR	1250- 0210
5 40398	Lec	MA102	J Gatewood	3.0	MW	1250- 0210
15 40399	Lec	HU102	T Mack	3.0	TR	0400- 0520
3 40400	Lec	HU102	M Fuzie	3.0	MW	0230- 0350
40401	Lec	HU102	M Kovacs	3.0	T	0600- 0905
6 40402	Lec	SS111	D Luoma	3.0	W	0600- 0905
7 40403	Lec	HOL5	T Brett	3.0	R	0600- 0905
Above class meets at the Hollister Briggs site.						
40404	Lec	MHG12	S Sloan	3.0	W	0600- 0905
Above class meets at Morgan Hill Community site.						

ENGL 1B Composition and Literature

Transferable: CSU, UC; CSU-GE:C, IGETC:3B; GAV-GE:C2; CAN:ENGL4, ENGL SEQ A

English 1B continues the work begun in 1A, but now the emphasis shifts to writing expository prose in conjunction with reading and analyzing imaginative literature. Students are to write as fledgling critics and use the text as a basis for other forms of reflection. The reading requirement includes short stories, poetry, drama, and at least two novels. Course work will also include fundamentals of research writing. **PREREQUISITE:** English 1A with a grade of "C" or better.

40405	Online		K Warren	3.0		
40406	Lec	MHG13	S White	3.0	MW	0400- 0520
Above class meets at Morgan Hill Community site.						
40407	Lec	HU102	G Richards	3.0	TR	0945- 1105
40408	Lec	HU103	M Bragger	3.0	F	0900- 1205
40409	Lec	HU103	E Crook	3.0	MW	1250- 0210
40410	Online		O Osikomaiya	3.0		
40411	Lec	HU103	A Mora	3.0	MW	0810- 0930
40412	Lec	HU103	J Hooper	3.0	TR	0230- 0350
8 40413	Lec	HU103	S Hirasuna	3.0	TR	1120- 1240
9 40414	Lec	HU102	T Brett	3.0	W	0600- 0905

See page 40 to locate your class theme by numbered bullet 1 2 3 4

CRN Type Room Instructor Units Days Times Dates

ENGL 1C Critical Reasoning and Writing

Transferable: CSU, UC; CSU-GE:A3, IGETC:1B; GAV-GE:C2

This course is designed to develop critical thinking, reading, and writing skills beyond the level achieved in English 1A. The emphasis is on critical analysis of arguments and the development of the ability to integrate the principles of critical thinking into essay writing. **PREREQUISITE:** English 1A with a grade of "C" or better.

40415	Online		D Luoma	3.0		
40416	Lec	HU102	K Hull	3.0	MW	0945- 1105
This service learning course involves community work.						
40417	Lec	HOL1	G Mora	3.0	MW	0400- 0520
Above class meets at the Hollister Briggs site.						
40418	Lec	HU103	D Condon	3.0	TR	0810- 0930
40419	Lec	HU103	M Oral	3.0	MW	0230- 0350
40420	Lec	HU103	K Smith	3.0	TR	0400- 0520
10 40421	Lec	HU102	T Brett	3.0	M	0600- 0905

ENGL 4B British Literature - 1798 to Present

Transferable: CSU, UC; CSU-GE:C2, IGETC:3B; GAV-GE:C2; CAN:ENGL10, ENGL SEQ B

This course is a study of the masters of British Literature from 1798 to present. In this course we will read and analyze the literature of Blake, Wordsworth, Coleridge, Byron, Shelley, Keats, Tennyson, Browning, Arnold, Clough, Hopkins, Rossetti, Bronte, Yeats, Joyce, Woolf, Lawrence, Eliot, and Forster. Note: this course need not be taken in sequence. **PREREQUISITE:** Eligible for English 1A.

40505	Lec	SS203	S Sandler	3.0	MW	1120- 1240
-------	-----	-------	-----------	-----	----	------------

ENGL 9A Introduction to Creative Writing

Transferable: CSU, UC; CSU-GE:C2; GAV-GE:C2; CAN:ENGL6

This course allows writers to experiment with various forms of poetry and prose, including drama, fiction, poetry, and narrative non-fiction and includes the writing, reading, and discussion of such works. The class is primarily experiential, providing many opportunities for generation of new pieces of writing, some time for gentle encouraging feedback, and a focus on terminology to develop better understandings of both the process and craft of creative writing.

40506	Lec	SS111	K Smith	3.0	MW	1250- 0210
-------	-----	-------	---------	-----	----	------------

ENGLISH COMPOSITION AND READING COURSE SEQUENCE

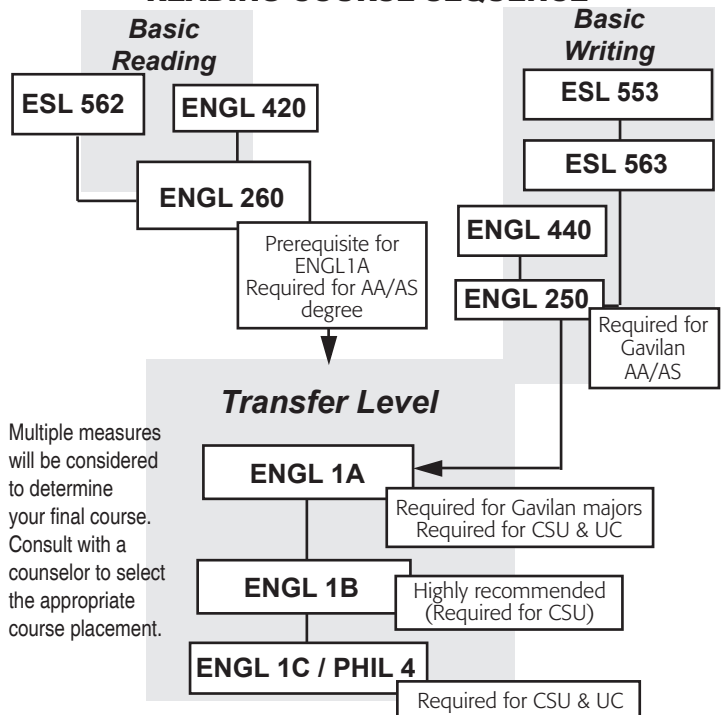

Choose a **THEME** for your English class:

Find the number, by the course section number, that corresponds to a theme below.

- ① Puento: Develop writing skills through an emphasis on Chicano / Latino literature.
- ② Investigate environmental issues, particularly those connected to what we eat and where we live.
- ③ Investigate environmental ethics and apply yours to real-life situations.
- ④ The American Dream: Revisit the land of freedom and equality.
- ⑤ Re-examine American culture and values by looking at the modern myths and controversial issues of our time.
- ⑥ Read works by scientists, journalists, mystics, and reformers about nature and the wilderness.
- ⑦ Explore the exciting realm of science and discover who we are and how we got here, and learn about the scientists and explorers who got us here.
- ⑧ Examine short stories, poetry, drama, and the novel using formalist, historical and biographical criticism.
- ⑨ Explore the great literature of the human condition, challenging you to respond to literary art, science fiction, music, tragedy, and the joy of life and living.
- ⑩ Learn to think courageously and intelligently through challenging the pseudoscientific, the paranormal, and the make-believe world of nutty beliefs and scams.
- ⑪ Explore American consumerism and wild alternatives.
- ⑫ First Year Experience with Service Learning: Learn to critically read, write, and think about contemporary issues.
- ⑬ Examine current American themes such as electronic addictions, immigration, and the media to discover our own personal view of America.
- ⑭ Examine the “invisible world” of the illiterate, and how those who do not have reading skills often feel like second-class citizens.
- ⑮ Explore human rights issues through fiction, non-fiction, videos, and music. Check out youthforhumanrights.org for an intro to course concepts.

Visit www.gavilan.edu/pio/GavArts.html for Gavilan's entertainment and events



We have now made it easier for you to find out what is happening at Gavilan College.

CRN Type Room Instructor Units Days Times Dates

ENGL 9B Advanced Creative Writing

Transferable: CSU, UC; CSU-GE:C2; GAV-GE:C2

This class is a continuation of English 9A, with an emphasis on further development on the craft and production of various forms of poetry and prose, including drama, fiction, poetry, and narrative non-fiction and includes the writing, reading, and discussion of such works. The class remains primarily experiential, providing many opportunities for generation of new pieces of writing, some time for gentle encouraging feedback with a greater focus on developing leadership skills in that area as well as a deepening knowledge of terminology, in order to develop better understandings of both the process and craft of creative writing. **PREREQUISITE:** English 9A with a grade of 'pass' or C or better.

40507 Lec SS111 K Smith 3.0 MW 1250- 0210

ENGL 9C Poetry Writing

Transferable: CSU, UC; CSU-GE:C2; GAV-GE:C2

This course is an immersion into poetry and its creation. The class is primarily experiential, providing many opportunities for the generation of new poems and space for gentle encouraging feedback. Emphasis will be placed on a variety of poetic forms and the development of terminology useful in both creating and analyzing poetry. **PREREQUISITE:** English 9A with a grade of 'pass' or C or better.

40508 Lec SS111 K Smith 3.0 MW 1250- 0210

ENGL 12B Tutoring Writers: Training / Theory & Practice

Transferable: CSU

Fundamentals of compositional theory, the writing process, peer-to-peer communication, interacting with faculty and educational institutions and effective responses to writing will be covered. In addition, students will gain an understanding of the basic history, methodology and practice of writing pedagogy while developing a writing community that aids in connecting them to their own writing practice. **ADVISORY:** Eligible for English 1A.

40384 Lec SS111 K Warren 1.0 T 0300- 0400

ENGL 12C Tutoring Writers: Training / Theory & Practice

Transferable: CSU

Fundamentals of compositional theory, the writing process, peer-to-peer communication, interacting with faculty and educational institutions and effective responses to writing will be covered. In addition, students will gain an understanding of the basic history, methodology and practice of writing pedagogy while developing a writing community that aids in connecting them to their own writing practice. **ADVISORY:** Eligible for English 1A.

40385 Lec SS111 K Warren 1.0 T 0300- 0400

ENGL 12D Tutoring Writers: Training, Theory & Practice

Transferable: CSU

Fundamentals of compositional theory, the writing process, peer-to-peer communication, interacting with faculty and educational institutions and effective responses to writing will be covered. In addition, students will gain an understanding of the basic history, methodology and practice of writing pedagogy while developing a writing community that aids in connecting them to their own writing practice. **ADVISORY:** Eligible for English 1A.

40386 Lec SS111 K Warren 1.0 T 0300- 0400

ENGL 22 Field Work and Service

Transferable: CSU

Supervised field work within the college and with local agencies. Students serve in useful group activities in leadership roles prescribed for them by faculty or community agencies. A maximum of six units may be completed. This is a pass/no pass course. **REQUIRED:** Learning contracts must be filled out and signed by the student and the supervising instructor.

40423 Fld Ex LI119 K Warren 1.0

CRN	Type	Room	Instructor	Units	Days	Times	Dates
-----	------	------	------------	-------	------	-------	-------

ENGL 250P Practical Writing**Transferable:** No

This course covers writing clear, correct, effective essays and learning preliminary research skills. This course is pass/no pass. Also listed as English 250. COREQUISITE: ENGL 260P

The following classes are FIRST YEAR EXPERIENCE CLASSES, see page 41

40452	Lec	SS203	S Sandler	3.0	MW	0810-0930	
	Lab	LI120	S Sandler		M	0945-1035	
This class is part of a learning community. If you enroll you must also enroll in ENGL 260P #40463.							
40453	Lec	SS203	S Sandler	3.0	MW	0810-0930	
	Lab	LI120	S Sandler		W	0945-1035	
This class is part of a learning community. If you enroll you must also enroll in ENGL 260P #40464.							
40454	Lec	SS203	K Smith	3.0	TR	1250-0210	
	Lab	LI171	K Smith		T	0230-0320	
This class is part of a learning community. If you enroll you must also enroll in ENGL 260P #40465.							
40455	Lec	SS203	K Smith	3.0	TR	1250-0210	
	Lab	LI171	K Smith		R	0230-0320	
This class is part of a learning community. If you enroll you must also enroll in ENGL 260P #40466.							
40771	Lec	SS203	K Smith	3.0	MW	0230-0350	
	Lab	LI120	K Smith		M	0400-0450	
This class is part of a learning community. If you enroll you must also enroll in ENGL 260P #40773.							
40772	Lec	SS203	K Smith	3.0	MW	0230-0350	
	Lab	LI120	K Smith		W	0400-0450	
This class is part of a learning community. If you enroll you must also enroll in ENGL 260P #40774.							

ENGL 260 Preparation for College Reading**Transferable:** No; GAV-GE:A3

This is a course presenting strategies in the technique and practice of college level critical reading and thinking skills. Also listed as English 260P. PREREQUISITE: Completion of English 420 or ESL 562 with a grade of 'C' or better or Assessment recommendation.

40456	Lec	HU102	K Hull	3.0	MW	0810-0930	
40457	Lec	HU102	K Hull	3.0	F	0910-1215	

The following two are FIRST YEAR EXPERIENCE CLASSES, see page 41

⑫40458	Lec	HU102	J Gatewood	3.0	MW	1120-1240	
This class is part of a learning community. If you enroll you must also enroll in ENGL 250 #40441. This service learning course involves community work.							
⑫40459	Lec	HU102	J Gatewood	3.0	MW	1120-1240	
This class is part of a learning community. If you enroll you must also enroll in ENGL 250 #40442. This service learning course involves community work.							
40462	Lec	HOL4	A Shelley	3.0	MW	0530-0650	
Above class meets at the Hollister Briggs site.							

ENGL 260P Preparation for College Reading**Transferable:** No

This is a course presenting strategies in the technique and practice of college level critical reading and thinking skills. This course is pass/no pass. Also listed as English 260. COREQUISITE: ENGL 250P

The following classes are FIRST YEAR EXPERIENCE CLASSES, see page 41

40463	Lec	SS203	S Sandler	3.0	TR	0810-0930	
This class is part of a learning community. If you enroll you must also enroll in ENGL 250P #40452.							
40464	Lec	SS203	S Sandler	3.0	TR	0810-0930	
This class is part of a learning community. If you enroll you must also enroll in ENGL 250P #40453.							
40465	Lec	SS203	J Hooper	3.0	TR	1120-1240	
This class is part of a learning community. If you enroll you must also enroll in ENGL 250P #40454.							
40466	Lec	SS203	J Hooper	3.0	TR	1120-1240	
This class is part of a learning community. If you enroll you must also enroll in ENGL 250P #40455.							
40773	Lec	SS203	J Hooper	3.0	MW	1250-0210	
This class is part of a learning community. If you enroll you must also enroll in ENGL 250P #40771.							
40774	Lec	SS203	J Hooper	3.0	MW	1250-0210	
This class is part of a learning community. If you enroll you must also enroll in ENGL 250P #40772.							

See page 40 to locate your class theme by numbered bullet ①②③

CRN	Type	Room	Instructor	Units	Days	Times	Dates
-----	------	------	------------	-------	------	-------	-------

ENGL 411 Reading and Writing Workshop**Transferable:** No

English 411 builds fundamental skills in reading and writing through a hands-on workshop approach. Students apply skill-building techniques to authentic reading and writing tasks, such as reading books and writing essays. The emphasis of the course is on process and awareness of effective literacy strategies. Students will leave the course with more confidence in themselves as readers and writers and with gained skills and tools to apply to their future coursework. This course is designed for students who need or desire to approach college-level reading and writing as a slower pace. Units earned in this course do not count toward the associate degree and/or certain certificate requirements. This is a pass/no pass course.

40748	L/L	SS111	J Hooper	4.0	MW	0900-1020	
	L/L	SS111	J Hooper		W	1030-1155	
	L/L	LI171	J Hooper		M	1030-1155	

ENGL 420 Reading Improvement**Transferable:** No

This is a practical, "how to" course teaching various methods of learning and reading college material. Using group and individual instruction in vocabulary, comprehension, and study skills, the students will increase their ability to survive academically, to profit, grow and succeed in all college courses, and to enjoy reading and learning. Units earned in this course do not count toward the associate degree and/or certain certificate requirements. This course has the option of a letter grade or pass/no pass. PREREQUISITE: Satisfactory score on the English placement examination.

40467	Lec	HOL1	K Scimeca	3.0	MW	0945-1105	
	Lab	HOL1	K Scimeca		F	0910-1000	
Above class meets at the Hollister Briggs site. This service learning course involves community work.							
40468	Lec	HOL1	K Scimeca	3.0	MW	0945-1105	
	Lab	HOL1	K Scimeca		F	1110-1200	
Above class meets at the Hollister Briggs site. This service learning course involves community work.							
40469	Lec	MA102	S Hirasuna	3.0	TR	0945-1105	
	Lab	MA102	S Hirasuna		R	0845-0935	
40470	Lec	MA102	S Hirasuna	3.0	TR	0945-1105	
	Lab	MA102	S Hirasuna		T	0845-0935	

The following two are FIRST YEAR EXPERIENCE CLASSES, see page 41

40471	Lec	SS111	J McMillen	3.0	TR	1120-1240	
	Lab	LI171	J McMillen		T	1010-1100	
This class is part of a learning community. If you enroll you must also enroll in ENGL 440 #40499.							
40472	Lec	SS111	J McMillen	3.0	TR	1120-1240	
	Lab	LI171	J McMillen		W	1120-1210	
This class is part of a learning community. If you enroll you must also enroll in ENGL 440 #40500.							
40473	Lec	HU103	S Arora	3.0	TR	0530-0650	
	Lab	HU103	S Arora		T	0700-0750	
40474	Lec	HU103	S Arora	3.0	TR	0530-0650	
	Lab	HU103	S Arora		R	0700-0750	



The Puente Project is a two-semester program that combines three components: writing, counseling and mentoring to support students to transfer to four-year universities and colleges. The Guidance 1 course focuses on self assessment and career development. The English 1A course focuses on Mexican American / Latino literature. The program also includes a student leadership conference, university visits and mentor/student socials.

The program is open to all eligible students. For more information, call **Celia Marquez, Puente Coordinator at 408-848-4807.**

Required: Complete a program application with the Puente Counselor prior to registration.

GUID 1 CRN 40352 & ENGL 1A CRN 40396

CRN Type Room Instructor Units Days Times Dates

ENGL 440 Basic Writing

Transferable: No

This is an intensive study and application of basic grammar, sentence, and essay writing skills within the context of composing short essays. Units earned in this course do not count toward the associate degree and/or certain certificate requirements. **PREREQUISITE:** Satisfactory score on the English placement examination.

40495	Lec	HU103	E Crook	3.0	MW	1120- 1240
	Lab	LI171	E Crook		T	1120- 1210
40496	Lec	HU103	E Crook	3.0	MW	1120- 1240
	Lab	LI171	E Crook		R	1120- 1210
40497	Lec	HOL1	K Scimeca	3.0	MW	1120- 1240
	Lab	HOL1	K Scimeca		F	1010- 1100
Above class meets at the Hollister Briggs site.						
40498	Lec	HOL1	K Scimeca	3.0	MW	1120- 1240
	Lab	HOL1	K Scimeca		F	1210- 0100
Above class meets at the Hollister Briggs site.						
40499	Lec	SS111	J McMillen	3.0	TR	1250- 0210
	Lab	LI171	J McMillen		R	1010- 1100
This class is part of a learning community. If you enroll you must also enroll in ENGL 420 #40471.						
40500	Lec	SS111	J McMillen	3.0	TR	1250- 0210
	Lab	LI171	J McMillen		W	1220- 0110
This class is part of a learning community. If you enroll you must also enroll in ENGL 420 #40472.						
40501	Lec	HU103	E Crook	3.0	TR	1250- 0210
	Lab	LI120	E Crook		T	0230- 0320
40502	Lec	HU103	E Crook	3.0	TR	1250- 0210
	Lab	LI120	E Crook		R	0230- 0320
14 40503	Lec	HU103	J Penkethman	3.0	MW	0530- 0650
	Lab	LI120	J Penkethman		M	0700- 0750
14 40504	Lec	HU103	J Penkethman	3.0	MW	0530- 0650
	Lab	LI120	J Penkethman		W	0700- 0750

CRN Type Room Instructor Units Days Times Dates

ENGLISH AS A SECOND LANGUAGE

ESL 510B Basic ESL II

Transferable: No

This course is a continuation of ESL 510A. This is an intensive, integrated-skill program for students who function in a limited way in English. Through listening, speaking, reading and writing activities, students continue learning to use the structures of English with increasing accuracy, while gaining further basic life skills. **ADVISORY:** ESL 510A or ESL assessment recommendation.

40064	Lec	CE500	K Campbell	9.0	MTWRF	0945- 1115
	Online		K Campbell			
This HYBRID lecture/online class will be delivered partially over the internet.						

ESL 521 Beginning ESL Listening / Speaking

Transferable: No

This course develops basic listening and speaking skills, moving from a functional survival context to academic readiness. Activities are directed at providing practice through listening exercises, role-play, pair work, small and large group discussion, interviews, and oral presentations. **ADVISORY:** ESL 510B or ESL Assessment Test Recommendation. Recommended concurrent enrollment in ESL 522 and 523.

40065	Lec	CE500	K Baameur	4.0	MWF	0810- 0920
	Online		K Baameur			
This HYBRID lecture/online class will be delivered partially over the internet.						

ESL 522 Beginning ESL Reading / Vocabulary

Transferable: No

This course begins the development of reading skills and vocabulary through the application of different reading strategies to a variety of selections on topics of interest to academically-bound students. **ADVISORY:** ESL 510B or 510C or Assessment recommendation. Recommended concurrent enrollment in ESL 521 and 523.

40066	Lec	CE500	C Hardy	3.0	TR	0810- 0930
-------	-----	-------	---------	-----	----	------------

ESL 523 Beginning ESL Grammar / Writing

Transferable: No

This is a beginning grammar/writing course for students with very basic grammar. The focus is on basic grammatical structures, punctuation and sentence skills. **ADVISORY:** ESL 510B or ESL Assessment Test recommendation. Recommended concurrent enrollment in ESL 521 and ESL 522.

40067	Lec	CE500	C Gane	5.0	MTWF	1130- 1235
	Online		C Gane			
This HYBRID lecture/online class will be delivered partially over the internet.						

ESL 531 Intermediate ESL Listening / Speaking I

Transferable: No

In this course, listening and speaking skills are developed through extended listening exercises, open-ended dialogues, pair and group discussions, oral interviews, and oral reports. **PREREQUISITE:** ESL 521 or ESL 528 with a grade of 'C' or better or ESL Assessment Recommendation. Recommended concurrent enrollment in ESL 532 and 533.

40068	Lec	HU104	C Hardy	4.0	MWF	1105- 1215
	Online		C Hardy			
This HYBRID lecture/online class will be delivered partially over the internet.						

NON CREDIT

ESL 777	ESL 778	VOCATIONAL VESL ESL 704A/B To move from noncredit to credit ESL classes students must take an ESL assessment.
ESL 779	ESL 780	
ESL 781	ESL 782	

OVERVIEW of ESL COURSES

CREDIT - ACADEMIC TRACK

Basic	510A				
	510B				
Beginning	521 L/S	522R	523GW	527RW	528L/S
	531 L/S	532R	533GW	537RW	538L/S
Intermediate I	541 L/S	542R	543GW	547RW	548L/S
Intermediate II		552R	553W	554G	557VESL
Advanced I	561 L/S	562R	563W	564G	567VESL
Advanced II					

ENGL 260 ENGL 250

SUPPLEMENTARY ESL COURSES:

ESL 546	Intro Computers/ESL
ESL 556	Intro Competency/ESL
ESL 581	Pronunciation I
ESL 582	Pronunciation II
ESL 584	Culture through Film
ESL 585	Editing for ESL Writers

ACADEMIC PROGRAMS or **VOCATIONAL PROGRAMS**

¿Es el inglés su segundo idioma?

Consulte la página 99 para información en Español sobre el examen de evaluación de ESL.

ONLINE CLASSES: You must have an email account to take this course. Start your course by going to <http://www.gavilan.edu/disted>. Unless you have made prior arrangements with the instructor, you **MUST** log on by 11:59 pm on the first day of the course. Late adds must login within 24 hours of adding this course. If you miss the deadline you may be dropped. For help, contact your instructor or email disted@gavilan.edu.

CRN	Type	Room	Instructor	Units	Days	Times	Dates
-----	------	------	------------	-------	------	-------	-------

ESL 532 Intermediate ESL Reading / Vocabulary I**Transferable:** No

This course continues the development of reading skills and vocabulary through the application of different reading strategies to a variety of selections on topics of interest to academically-bound students. PREREQUISITE: ESL 522 with a grade of 'C' or better or ESL assessment recommendation. Recommended concurrent enrollment in ESL 531 and 533.

40069	Lec	HU104	N Cisneros	3.0	TR	0940- 1100	
-------	-----	-------	------------	-----	----	------------	--

ESL 533 Intermediate ESL Grammar / Writing I**Transferable:** No

This course involves the practice and refinement of sentence and paragraph skills, structure and punctuation. Students will learn basic use of the computer as a writing tool. PREREQUISITE: ESL 523 with a grade of C or better or ESL Assessment Test recommendation. ADVISORY: Recommended concurrent enrollment in ESL 531 and ESL 532.

40070	Lec	HU101	K Campbell	5.0	MTWR	1225- 0130	
	Online		K Campbell				

This HYBRID lecture/online class will be delivered partially over the internet.

ESL 541 Intermediate ESL Listening / Speaking II**Transferable:** No

This course expands listening and speaking skills through extended listening exercises, open-ended dialogues, pair and group discussions, oral interviews, and oral reports. Students broaden vocabulary while listening to and speaking in both formal and informal, conversational and academic situations. PREREQUISITE: ESL 531 or ESL 538 with a grade of 'C' or better or ESL assessment recommendation. Recommended concurrent enrollment in ESL 542 and 543.

40071	Lec	HU104	R Rodriguez	4.0	TRF	1225- 0135	
	Online		R Rodriguez				

This HYBRID lecture/online class will be delivered partially over the internet.

ESL 542 Intermediate ESL Reading / Vocabulary II**Transferable:** No

This course begins the expansion of reading skills and vocabulary development through the application of different reading strategies to a variety of selections on topics of interest to academically-bound students including selections from literature. PREREQUISITE: ESL 532 with a grade of 'C' or better or ESL Assessment Recommendation. Recommended concurrent enrollment in ESL 541 and 543.

40072	Lec	HU101	L Carrillo	3.0	TR	0810- 0930	
-------	-----	-------	------------	-----	----	------------	--

ESL 543 Intermediate ESL Grammar / Writing II**Transferable:** No

This course involves the expansion of sentence and paragraph skills, structure, and punctuation. Students will learn basic use of the computer as a writing tool. PREREQUISITE: ESL 533 with a grade of C or better or ESL assessment recommendation. ADVISORY: Recommended concurrent enrollment in ESL 541 and ESL 542.

40073	Lec	LI100	B Lawn	5.0	TWRF	0945- 1050	
	Online		B Lawn				

This HYBRID lecture/online class will be delivered partially over the internet.

ESL 546 Introduction to Computers for ESL Students**Transferable:** No

Introduction to basic computer hardware functions and terminology; overview of Windows operating environment and word processing for ESL students. ADVISORY: CSIS 122. Eligible for Gavilan College ESL Program Intermediate.

40074	Lec	BU119	C Gane	1.0	R	1115- 1205	
-------	-----	-------	--------	-----	---	------------	--

CRN	Type	Room	Instructor	Units	Days	Times	Dates
-----	------	------	------------	-------	------	-------	-------

ESL 552 Advanced ESL Reading / Vocabulary I**Transferable:** No

This course focuses on academic and critical thinking skills needed to increase reading comprehension and efficiency. Emphasis is on analyzing, making inferences, taking notes, supporting opinions, summarizing and expanding vocabulary. Readings are from academic texts and literature. PREREQUISITE: ESL 542 with a grade of 'C' or better or ESL assessment recommendation. Recommended concurrent enrollment in ESL 553 and 554.

40075	Lec	HU101	K Baameur	4.0	MWF	1110- 1220	
-------	-----	-------	-----------	-----	-----	------------	--

ESL 553 Advanced ESL Composition I**Transferable:** No

This course is a composition course for ESL students that develops college composition skills through a review of the parts and elements of the English paragraph and an introduction to the essay form. The course focuses on the development of a paragraph and expands to the writing of multiple paragraphs in an essay. Basic rhetorical patterns and methods of organization are covered using the multiple-draft approach to writing. PREREQUISITE: ESL 543 with a grade of C or better or ESL Assessment Test recommendation. ADVISORY: Recommended concurrent enrollment in ESL 552 and ESL 554.

40076	Lec	HU101	R Rodriguez	5.0	TWRF	0945- 1050	
	Online		R Rodriguez				

This HYBRID lecture/online class will be delivered partially over the internet.

ESL 554 Advanced ESL Grammar I**Transferable:** No

This course is designed to help students improve their grammar usage so that they will be able to expand their use of grammar structures in oral and written communication. Students begin the study of more sophisticated grammar structures such as past and future perfect, passive voice, and modal auxiliaries for past time, and they review perfect and modals for present and future time. Students will enhance their understanding of grammar by comparing and contrasting new and previously encountered structures and better appreciate the subtleties of English grammar. PREREQUISITE: ESL 543 with a grade of 'C' or better or ESL Assessment Test Recommendation. ADVISORY: Recommended concurrent enrollment in ESL 552 and ESL 553.

40077	Lec	HU104	N Cisneros	5.0	MTRF	0810- 0915	
	Online		N Cisneros				

This HYBRID lecture/online class will be delivered partially over the internet.

ESL 562 Advanced ESL Reading / Vocabulary II**Transferable:** No

This course prepares ESL students for mainstream college classes by reviewing a variety of reading skills, strategies, and topics from different academic disciplines. Students expand their academic vocabulary and read short stories or a novel for literary appreciation. PREREQUISITE: ESL 552 with a grade of 'C' or better or ESL assessment recommendation. Recommended concurrent enrollment in ESL 561 and/or ESL 564 and ESL 563.

40078	Lec	LI100	B Lawn	4.0	MWF	1105- 1215	
-------	-----	-------	--------	-----	-----	------------	--

ESL 563 Advanced ESL Composition II**Transferable:** No

This course is a composition course for ESL students that refines and further expands college composition skills through the writing of essays. The course focuses on the structuring and development of an essay with the use of personal examples. Students write in response to a variety of prompts using different rhetorical patterns such as classification, narration, argumentation, and cause/effect. PREREQUISITE: ESL 552, 553, and 554 with a grade of 'C' or better or ESL assessment recommendation.

40079	Lec	SS203	K Diehl	5.0	TWRF	0945- 1050	
	Online		K Diehl				

This HYBRID lecture/online class will be delivered partially over the internet.

CRN	Type	Room	Instructor	Units	Days	Times	Dates
-----	------	------	------------	-------	------	-------	-------

ESL 564 Advanced ESL Grammar II

Transferable: No

This course is designed to expand grammar usage to include adjective, noun, and adverb clauses in oral and written communication. Students learn the meaning and use of clause connectors and are introduced to conditionals, both real and unreal. These grammar structures constitute some of the most complex structures in English and expose students to a rich variety of structures that can effectively enhance their oral and written expression. **PREREQUISITE:** ESL 554 with a grade of 'C' or better or ESL Assessment Recommendation. **ADVISORY:** Recommended concurrent enrollment in ESL 562 and ESL 563.

40080	Lec	LI100	B Lawn	5.0	MTWR	1230-0135
	Online		B Lawn			

This HYBRID lecture/online class will be delivered partially over the internet.

ENVIRONMENTAL SCIENCE

ES 1 Introduction to Environmental Science

Transferable: CSU

This course is intended to provide students with an introduction to environmental science and critical thinking in areas of informed decision making on issues related to use of natural resources including those related to energy, transportation, land use and waste. The first half of the course is devoted to developing and understanding of how ecosystems operate. During the second half of the course various issues related to use of natural resources by growing human populations are examined.

40735	L/L	LS102	R Morales	4.0	MW	0810-1105
-------	-----	-------	-----------	-----	----	-----------

FRENCH

FRNH 1B Elementary French

Transferable: CSU, UC; CSU-GE:C2, IGETC:6A; GAV-GE:C2, F

Continuation of French 1A with further development of the four skills of understanding, speaking, reading, and writing. Continued emphasis on culture. **PREREQUISITE:** French 1A, or equivalent.

40373	Lec	LI100	C Varjavandi	5.0	MTWR	0810-0915
	Online		C Varjavandi			

This HYBRID lecture/online class will be delivered partially over the internet.

FRNH 23 Independent Study

Transferable: CSU

Designed to afford selected students specialized opportunities for exploring areas at the independent study level. The courses may involve extensive library work, research in the community, or special projects. May be repeated until six units of credit are accrued. This course has the option of a letter grade or pass/no pass. **REQUIRED:** The study outline prepared by the student and the instructor must be filed with the department and the dean.

40372	Ind	SS111	C Varjavandi	1.0		
-------	-----	-------	--------------	-----	--	--

GEOGRAPHY

GEOG 1 Physical Geography

Transferable: CSU, UC; CSU-GE:B1, B3, IGETC:5A; GAV-GE:B1, B3; CAN:GEOG6

An introductory study of the basic physical elements of geography including climate, land forms, soils, water, and natural vegetation. The laboratory will include the tools and methods of geographers. **ADVISORY:** Eligible for English 250 and English 260.

40008	L/L	HOL5	D Willahan	3.0	MW	0945-1210
-------	-----	------	------------	-----	----	-----------

Above class meets at the Hollister Briggs site.



THIS SYMBOL MEANS IT IS A **HYBRID** LECTURE / ONLINE CLASS, THAT WILL BE PARTIALLY OVER THE INTERNET.

VISIT WWW.GAVILAN.EDU/DISTED/ FOR DETAILS.

CRN	Type	Room	Instructor	Units	Days	Times	Dates
-----	------	------	------------	-------	------	-------	-------

GEOLOGY

GEOL 1 Introduction to Geology

Transferable: CSU, UC; CSU-GE:B1, B3, IGETC:5A; GAV-GE:B1, B3; CAN:GEOL2
A study of the earth and the physical properties which modify the earth; minerals, rocks, geologic structures and processes. **ADVISORY:** Eligible for English 250 and English 260.

40568	L/L	SS206	D Willahan	4.0	MW	1250-0355
40569	L/L	SS206	P Stoffer	4.0	TR	0230-0535

GEOL 23 Independent Study

Transferable: CSU

Designed to afford selected students specialized opportunities for exploring areas at the independent study level. The courses may involve extensive library work, research in the community, or special projects. May be repeated until six units of credit are accrued. This course has the option of a letter grade or pass/no pass. **REQUIRED:** The study outline prepared by the student and the instructor must be filed with the department and the dean.

40570	Ind	SS206	D Willahan	1.0		
-------	-----	-------	------------	-----	--	--

GUIDANCE

GUID 1 Self-Assessment and Career Development

Transferable: CSU; CSU-GE:E2; GAV-GE:E2

This course is designed to assist the student in learning more about personal values, personality, interests, exploration of career choice, and occupational opportunities through the use of various personal assessment instruments. The delivery options for this course also include online and self-paced formats. This course is also listed as PSYC 5. **ADVISORY:** Eligible for English 250 and English 260. \$12 fee will be charged for career assessment materials.

40350	Lec	HU104	C Velarde-Barros	3.0	MW	0400-0520
						This course is also listed at PSYC 5 CRN 40371.
40351	Online		L Tenney	3.0		01/31/13 - 05/24/13
						This course is also listed as PSYC 5 CRN 40374
40352	Lec	PB7	C Marquez	3.0	MW	1120-1240
						This course is also listed as PSYC 5 CRN 40375 This class is part of the PUENTE Program. If you enroll you must also enroll in ENGL 1A #40396.
40353	Lec	SBHS275	J Caffiero	3.0	TR	0400-0520
						Above class meets off-campus: This course is also listed at PSYC 5 CRN 40376. Course is held at San Benito High School, room 275

GUID 6 Life Skills for Higher Education

Transferable: CSU, UC; CSU-GE:E2; GAV-GE:E2

This course will address a multitude of cultural learning styles, with emphasis on attaining professional, personal and academic goals in a diverse society. **ADVISORY:** Eligible for English 25 and 260. See course catalog for full course description.

40828	Lec	GHS Library	E Gilstrap	2.0	T	0330-0530
						This course meets at GHS in the Library. This course is part of the High Step Program. This course is open to all students.

GUID 22 Field Work and Service

Transferable: CSU

Supervised field work within the college and with local agencies. Students serve in useful group activities in leadership roles prescribed for them by faculty or community agencies. A maximum of six units may be completed. This is a pass/no pass course. **REQUIRED:** Learning contracts must be filled out and signed by the student and the supervising instructor.

40684	Fld Ex	LI105	J Maringer-Cantu	1.0		
						Contact the Disability Resource Center (DRC) office. Open Entry/Open Exit

GUID 530 Job Readiness

Transferable: No

This course is designed to provide a comprehensive, well-organized approach to assist individuals with the identification of occupational choices and the development of job readiness skills necessary to obtain and maintain employment in a competitive or supported work setting. May be repeated twice for credit. This course has the option of a letter grade or pass/no pass.

40685	Lec	BU103	L Franklin	3.0	MW	0945-1105
						This Service Learning section involves community work.

CRN Type Room Instructor Units Days Times Dates

GUID 550 Supervised Tutoring

Transferable: No

Laboratory class emphasizing college learning skills, appropriate study techniques, and learning assistance utilizing one-to-one or small group tutorial.

40658	Lab	Math Lab			
40659	Lab	Writing Center			
40788	Lab	Tutoring Center			
40789	Lab	Computer Place			
40790	Lab	Digital Media Lab			
40791	Lab	Health Occupations Lab			

GUID 557 Learning Skills Evaluation

Transferable: No

This course provides an evaluation of the student's cognitive/perceptual abilities and basic skills academic achievement. The evaluation results are used to determine the student's eligibility for Learning Disabilities Services, to develop individual educational plans, and to improve the student's understanding of their own learning strengths and weaknesses. The evaluation is conducted on a one-to-one basis by appointment. Students receive skills training to assist them with their learning difficulties. Units earned in this course do not count toward the associate degree and/or certificate requirements. This is a pass/no pass course.

40686	Lab	LI117	L Burgman R Overson	.5	Open Entry/Open Exit
-------	-----	-------	------------------------	----	----------------------

Make an appointment with the Disability Resource Center (DRC) office (LI 117).

GUID 558 Learning Skills Laboratory

Transferable: No

The Learning Skills Laboratory is designed to assist students who are eligible to receive Learning Disabilities Services and/or have demonstrated academic deficits. The course content is individualized and based on Student Educational Contracts which are developed for each student. Students receive supplemental instruction, academic support, and learning strategy suggestions appropriate for their individual cognitive, perceptual, and academic strengths and weaknesses. Units earned do not count towards the associate degree and/or certificate requirements. This is a pass/no pass course. ADVISORY: Completion of Guidance 557 or demonstrated academic deficit.

40687	Lab	LI116	R Overson L Burgman	.5	Open Entry/Open Exit
40688	Lab	LI116	R Overson L Burgman	1.0	Open Entry/Open Exit
40689	Lab	LI116	R Overson L Burgman	2.0	Open Entry/Open Exit

GUID 560 Individualized Learning Skills Development

Transferable: No

This class is designed to teach individual learning skills development to students who are eligible to receive learning disability services. The course content includes organizational skills, fundamental critical thinking and basic college survival skills. ADVISORY: Completion of GUID 557 or demonstrated academic deficit.

40691	Lab	BU103	R Overson	1.0	TR 1120- 1240
-------	-----	-------	-----------	-----	---------------

GUID 562 Directed Study Lab in Pre-Algebra

Transferable: No

This course is designed for students who have demonstrated difficulty in mastering basic mathematics or pre-algebra and who are eligible to receive Learning Disability Services. Course content parallels Mathematics 400 and Mathematics 402. Material is presented in a concrete, multi-sensory manner, and the lab environment allows opportunity for immediate practice, questions, repetition, and review. This is a pass/no pass course. COREQUISITE: Concurrent enrollment in MATH 400 or MATH 402 is required. ADVISORY: Completion of GUID 557 and/or a demonstrated deficit in arithmetic. Recommended for students with verified learning disability.

40692	Lab	APE120	L Burgman	1.0	MW 0945- 1105
-------	-----	--------	-----------	-----	---------------

CRN Type Room Instructor Units Days Times Dates

GUID 563 Directed Study Lab in Algebra

Transferable: No

This course is designed for students who have demonstrated difficulty mastering elementary algebra and who are eligible to receive Learning Disability Services. Course content parallels Mathematics 205A and 205B. Material is presented in a concrete, multi-sensory manner, and the lab allows opportunity for immediate practice, questions, repetition, and review. This is a pass/no pass course. Concurrent enrollment in Math 205A, Math 205B or Math 205 is required.

40693	Lab	APE120	L Burgman	1.0	TR 0945- 1105
-------	-----	--------	-----------	-----	---------------

GUID 565 Directed Study Lab in Intermediate Algebra

Transferable: No

This course is designed for students who have demonstrated difficulty mastering intermediate algebra and who are eligible to receive Learning Disability Services. Course content parallels Mathematics 233A and 233B. Material is presented in a concrete, multi-sensory manner, and the lab allows opportunity for immediate practice, questions, repetition and review. This is a pass/no pass course. Concurrent enrollment in Math 233A, Math 233B or Math 233 is required.

40694	Lab	BU103	R Overson	1.0	MW 1120- 1240
-------	-----	-------	-----------	-----	---------------

HEALTH EDUCATION

HE 1 Health Education

Transferable: CSU, UC; CSU-GE:E2; GAV-GE:E2

This course focuses on attaining individual awareness, critical-thinking skills and self-responsibility relating to personal health. The interaction of individual physical, psychological, social, emotional, spiritual and environmental factors in determining health status is developed through integration of major concepts. This course has the option of a letter grade or pass/no pass. ADVISORY: Eligible for English 250 and English 260.

40660	Lec	LS106	S Dodd	3.0	TR 0945- 1105
-------	-----	-------	--------	-----	---------------

HE 2 Human Sexuality

Transferable: CSU, UC; CSU-GE:E2; GAV-GE:E2, F

Assists students in gaining increased knowledge, appreciation, and respect for their own sexuality, as well as others. Approved by the Board of Registered Nursing for 54 hours of continuing education credit (Provider #00892). ADVISORY: Eligible for English 250 and English 260

40661	Lec	LS106	R Monaco	3.0	R 0600- 0905
40662	Lec	HOL1	R Monaco	3.0	TR 0800- 0920

Above class meets at the Hollister Briggs site.

HISTORY

HIST 1 United States History through Reconstruction

Transferable: CSU, UC; CSU-GE:C2, D6, IGETC:3B, 4F, 7B; GAV-GE:C2, D2, F; CAN:HIST8, HIST SEQ B

History of the United States from the time before European contact with the Americas through Reconstruction. Emphasis will be placed on distinctive patterns of political, economic, social, intellectual, and geographic developments within their global context. At the conclusion of the course, the student should understand major themes in the history of the United States, and be able to explain various ways in which ideas about federal vs. state power, ethnicity, class, and gender divisions have influenced the nation's development. This course has the option of a letter grade or pass/no pass. ADVISORY: Eligible for English 250 and English 260.

40009	Lec	MHG12	C Mosher	3.0	MW 0945- 1105
Above class meets at Morgan Hill Community site.					
40010	Lec	SS210	E Luna	3.0	MW 0945- 1105
40011	Lec	HOL5	E Luna	3.0	T 0600- 0905
Above class meets at the Hollister Briggs site.					
40012	Lec	HOL2	E Luna	3.0	TR 1120- 1240
Above class meets at the Hollister Briggs site.					

CRN	Type	Room	Instructor	Units	Days	Times	Dates
-----	------	------	------------	-------	------	-------	-------

HIST 2 United States History Reconstruction to the Present

Transferable: CSU, UC; CSU-GE:C2, D6, IGETC:3B, 4F, 7B; GAV-GE:C2, D2; CAN:HIST10, HIST SEQ B

History of the United States from Reconstruction to the present. Emphasis will be placed on distinctive patterns of political, economic, social, intellectual, and geographic developments within their global context. At the conclusion of the course, the student should understand major themes in the history of the United States, and be able to explain various ways in which ideas about federal vs. state power, ethnicity, class, and gender divisions have influenced the nation's development. This course has the option of a letter grade or pass/no pass. ADVISORY: Eligible for English 1A.

40014	Lec	MHG12	C Mosher	3.0	MW	1120- 1240	
			Above class meets at Morgan Hill Community site.				
40015	Lec	SS210	L Halper	3.0	MW	0230- 0350	
40016	Lec	SS214	L Halper	3.0	TR	0945- 1105	
40017	Lec	HOL2	E Luna	3.0	TR	0945- 1105	
			Above class meets at the Hollister Briggs site.				
40018	Online		L Guardino	3.0			

HIST 4A Global History Before 1500

Transferable: CSU, UC; CSU-GE:C2, D6, IGETC:3B, 4F; GAV-GE:C2, D2, F

Beginning with the agricultural revolution, this course examines the development of global society before 1500. With attention to the interactions between humans and environment, developing states, cultures, economies, and social structures are examined in global context. The course emphasizes historical, analytical, and research skills. It asks students to analyze the evolution of global values, beliefs, and practices, as well as the conditions and results of social change. This course has the option of a letter grade or pass/no pass. ADVISORY: English 250 and English 260.

40019	Lec	SS210	L Halper	3.0	TR	1250- 0210	
-------	-----	-------	----------	-----	----	------------	--

HIST 6 Women's Lives in Recent United States History

Transferable: CSU, UC; CSU-GE:C2, D4, D6, IGETC:3B, 4F; GAV-GE:C2, D2, F

The class examines the construction of womanhood in the US during the twentieth century. The class explores the effects of gender, ethnicity, class, and sexual orientation upon women's experiences. Students will study the contributions of various individual women and groups of women in creating the modern United States, and will analyze social, political, economic, and cultural forces affecting women to both join and resist movements for social change. Students will also learn to apply contemporary feminist theory to traditional historical approaches. ADVISORY: English 250

40020	Lec	SS210	L Guardino	3.0	T	0600- 0905	
			This service learning course involves community work.				

HIST 7B History of Western Civilization

Transferable: CSU, UC; CSU-GE:C2, IGETC:3B; GAV-GE:C2; CAN:HIST4, HIST SEQ A

A study of major elements in western heritage from Renaissance Europe to the present. Emphasis is on ideas, attitudes and institutions basic to western civilization of enduring interest. ADVISORY: Eligible for English 1A.

40021	Lec	SS205	K Canelo	3.0	TR	0810- 0930	
-------	-----	-------	----------	-----	----	------------	--

HIST 12 Mexican American Cultural History

Transferable: CSU, UC; CSU-GE:C2, D3, D6, IGETC:3B, 4F; GAV-GE:D2, F

The Mexican American experience as influenced by society in the United States. Emphasis will be on the historical and contemporary contributions made by the Indian, Spanish, Mexican, and Mexican American. Emphasis will also be on the social, economic, and political milieu of the Mexican American within the context of the American society. This course has the option of a letter grade or pass/no pass. This course is also listed as HUM 12. ADVISORY: Eligible for English 1A.

40013	Lec	SS214	E Luna	3.0	MW	1250- 0210	
-------	-----	-------	--------	-----	----	------------	--

CRN	Type	Room	Instructor	Units	Days	Times	Dates
-----	------	------	------------	-------	------	-------	-------

HUMANITIES**HUM 4 Introduction to American Cinema**

Transferable: CSU, UC; CSU-GE:C2, IGETC:3B; GAV-GE:C2

This introductory course in film studies is a survey of the American film industry as an art form, as an industry, and as a system of representation and communication. The course explores how Hollywood films work technically, aesthetically, and culturally to reinforce and challenge America's national self-image. ADVISORY: English 440

40513	Online		G Richards	3.0			
-------	--------	--	------------	-----	--	--	--

HUM 10 Approaches to Contemporary Film

Transferable: CSU, UC; CSU-GE:C1, C2, IGETC:3B; GAV-GE:C1, C2

Approaches to Contemporary Film examines theories of film criticism as they apply to films from 1960 to the present. Students learn technical, visual, classical, historical, cultural, ideological, and aesthetic approaches to film and sample from a representative list of foreign and domestic movies. Special emphasis is given to new voices from non-American sources and to emerging voices in American cinema. ADVISORY: Eligibility for English 250 and 260.

40509	Lec	SS214	G Richards	3.0	MW	1120- 1240	
40510	Lec	SS214	G Richards	3.0	TR	1250- 0210	

HUM 12 Mexican American Cultural History

Transferable: CSU, UC; CSU-GE:C2, D3, D6, IGETC:3B, 4F; GAV-GE:D2, F

The Mexican American experience as influenced by society in the United States. Emphasis will be on the historical and contemporary contributions made by the Indian, Spanish, Mexican and Mexican American. Emphasis will also be on the social, economic, and political milieu of the Mexican American within the context of the American society. This course has the option of a letter grade or pass/no pass. Also listed as HIST 12. ADVISORY: Eligible for English 1A.

40511	Lec	SS210	E Luna	3.0	MW	1250- 0210	
-------	-----	-------	--------	-----	----	------------	--

HUM 23 Independent Study

Transferable: CSU

Designed to afford selected students specialized opportunities for exploring areas at the independent study level. The courses may involve extensive library work, research in the community, or special projects. May be repeated until six units of credit are accrued. This course has the option of a letter grade or pass/no pass. REQUIRED: The study outline prepared by the student and the instructor must be filed with the department and the dean.

40512	Ind	HU111	G Richards	1.0			
-------	-----	-------	------------	-----	--	--	--

JAPANESE**JPN 1A Elementary Japanese**

Transferable: CSU, UC; CSU-GE:C2; GAV-GE:C2, F

Beginning course with emphasis on understanding and speaking Japanese; introduction to reading and writing Japanese. This course will also introduce students to Japanese culture and institutions. This course has the option of a letter grade or pass/no pass.

40189	Lec	SS111	T Sakai	5.0	MW	0230- 0455	
	Online		T Sakai				
			This HYBRID lecture/online class will be delivered partially over the internet.				

ONLINE CLASSES: You must have an email account to take this course. Start your course by going to <http://www.gavilan.edu/disted>. Unless you have made prior arrangements with the instructor, you MUST log on by 11:59 pm on the first day of the course. Late adds must login within 24 hours of adding this course. If you miss the deadline you may be dropped. For help, contact your instructor or email disted@gavilan.edu.

CRN Type Room Instructor Units Days Times Dates

JPN 1B Elementary Japanese

Transferable: CSU, UC; CSU-GE:C2, IGETC:6A; GAV-GE:C2, F

Continue Japanese 1A with an emphasis on understanding, speaking, reading, and writing Japanese. This course will continue to introduce students to Japanese culture and institutions. This course has the option of a letter grade or pass/no pass. **PREREQUISITE:** Japanese 1A or equivalent.

40198 Lec SS205 T Sakai 5.0 TR 0230- 0455
 Online T Sakai
 This HYBRID lecture/online class will be delivered partially over the internet.

JPN 23 Independent Study

Transferable: CSU

Designed to afford selected students specialized opportunities for exploring areas at the independent study level. The course may involve extensive library work, research in the community, or special projects. May be repeated until six units of credit are accrued. This course has the option of a letter grade or pass/no pass. **REQUIRED:** The study outline prepared by the student and the instructor must be filed with the department and the dean.

40200 Ind SS111 T Sakai 1.0

JOURNALISM

JOUR 10 Mass Media and Society

Transferable: CSU, UC; CSU-GE:C2, D0, IGETC:4J; GAV-GE:C2, D2; CAN:JOUR4

This course helps students understand the 20th century revolution in mass media by focusing on the history, economics and social impact of the newspaper, book publishing, magazine, film, television, public relations, advertising and music industries. Students will study audience, propaganda and mass communication theory; and discuss new technology, ethnic media in the United States, ethical issues and attempts to regulate or control the media. Honors students will complete more in-depth analysis of media issues and will finish a media-related research project. This course is also listed as SOC 10. This course has the option of a letter grade or pass/no pass. **ADVISORY:** English 250, English 260.

40190 Lec AR103 J Janes 3.0 MW 0810- 0930

JOUR 190 Occupational Work Experience/Journalism

Transferable: CSU

Occupational work experience for students who have a job related to their major. A training plan is developed cooperatively between the employer, college and student. (P/NP grading) 75 hours per semester paid work = 1 unit. 60 hours non-paid (volunteer) work per semester = 1 unit. May be taken for a maximum total of 16 units. Minimum 2.00 GPA. **REQUIRED:** Declared vocational major.

40758 Wrk Ex LI101A S Sweeney 1.0

COMING FALL 2013!

PERSONAL TRAINER CERTIFICATE



**16 Unit Certificate
 Required Courses:
 BIO 15, KIN 3, KIN 84,
 KIN 85, CPR Certification,
 and either AH 11 or HE 1.**

START TAKING SOME OF THE REQUIRED COURSES NOW!
 IF YOU HAVE QUESTIONS OR WOULD LIKE MORE INFORMATION,
 PLEASE CONTACT **NIKKI DEQUIN**

408 848.4894 OR NDEQUIN@GAVILAN.EDU

CRN Type Room Instructor Units Days Times Dates

JPA LAW ENFORCEMENT

JLE 100 Basic Police Academy

Transferable: CSU

This 880 - 1080 variable unit course satisfies all minimum required training mandates governed by the Commission on Peace Officer Standards and Training (POST) entry level Peace Officers. The course includes fundamental principles, procedures and techniques of law enforcement, including: Criminal Law, Patrol procedures, Cultural Diversity, Investigative procedures, Report Writing, Defensive Tactics, Firearms, Leadership, Ethics, Community Relations, Police Vehicles Operations, Traffic Enforcement, Accident Investigation and First Aid/CPR. This course is open to those students who meet and satisfy entry requirements including written examination, physical fitness examination, DOJ fingerprint clearance and medical clearance. This course requires significant time commitments and outside course work including uniform preparation, homework assignments and equipment maintenance. This course may be repeated for credit. **PREREQUISITE:** 1. POST approved pre-entry English skills assessment examination provided by the Academy. 2. Penal Code Section 13511.5 requires that each applicant for admission to the basic course of training certified by the Commission (including the P.C. 832 course) that includes the carrying and use of firearms, and who is not sponsored by a local or other law enforcement agency, or is not a peace officer employed by the state or local agency, department, or district, shall be required to submit written certification from the Department of Justice that the applicant has no criminal history background which would disqualify him or her, from owning, possessing, or having under his or her control a firearm. 3. Medical clearance by a licensed physician.

40232 L/L S Cushing 22.0 MTWRF 0800- 0500
 10/29/12 - 04/25/13 Above class meets off-campus: Please contact South Bay Regional Public Training Consortium at (408) 270-6458.
 40775 L/L SNJOSE S Cushing 27.0 MTWRF 0800- 0500
 09/01/12 - 03/23/13

JLE 152 Skills and Knowledge

Transferable: CSU

This course offers in-service training curriculum, on an ongoing basis, for public safety personnel attending annual updates, re-certification or remediation, and assorted legal skills-related seminars mandated by the Commission on Peace Officer Standards and Training, the State Board of Corrections Standards in Training for Corrections and the Office of the State Fire Marshal on an ongoing basis. May be repeated a maximum of three times for credit. This is a pass/no pass course. **ADVISORY:** JLE 100

40040 L/L SNJOSE S Cushing 2.0 M 0700- 0500
 08/06/12 - 06/08/13 Above class meets off-campus: Please contact South Bay Regional Public Training Consortium at (408) 270-6458

KINESIOLOGY

KIN 5 Individual and Dual Sports

Transferable: CSU, UC; GAV-GE:E1

Designed for those planning to work with children in the field of physical education or recreation. Activities such as badminton, bowling, golf, tennis, and archery may be covered. This course has the option of a letter grade or pass/no pass. Previously listed as PE 5. **ADVISORY:** Eligible for English 250 and English 260.

40045 Lec GYGYM J Lango 3.0 MW 0945- 1105
 N Andrade

KIN 6 Games and Rhythms for Children

Transferable: CSU; GAV-GE:E1

Nature, function and organization of physical activities for the pre-school and elementary school age child. Emphasis is given to the understanding of psychomotor development and spatial awareness. Designed for those planning to work with children. This course has the option of a letter grade or pass/no pass. Also listed as Child Development 6. Previously listed as PE 6. **ADVISORY:** Eligible for English 250 and English 260.

40048 Lec APE120 S Dodd 3.0 TR 0810- 0930
 N Dequin