

GAVILAN COLLEGE

BIG TIME EDUCATION... HOMETOWN LOCATION

Spring 2011

SCHEDULE OF CLASSES

**Spring Semester
February 2-May 27**

Summer preview - p.98

Engineering - p. 77

English as a Second Language - p. 58

NEW: Introduction to Modern
International Terrorism, p. 31

Introduction to Design for Stage, Film and
Television. p. 81

Información en español - p. 100

GO RAMS

Connect with Gavilan College on Facebook, MySpace, and Twitter



Spring 2011

REGISTRATION

CALENDAR

A “returning” student has been absent from Gavilan College for one school year (3 semesters). New application required/Priority registration not available.

A “continuing” student was enrolled in the previous semester. No new application required/Priority Registration available if Orientation has been completed.

PRE-PRIORITY REGISTRATION DRC, EOPS and Veterans* only

Continuing students in DRC and EOPS may register on myGAV or with their counselor (see your program department for more details). Veterans not using VA benefits must meet with a general counselor for registration. Please bring a copy of your DD214 form.

Nov 18, 19, 22

* Pre-Priority registration is granted to any member or former member of the Armed Forces of the United States who is within two years of leaving active duty. Those eligible and using veteran’s benefits have been cleared to register on MyGAV.

PRIORITY REGISTRATION Continuing Students only.

In person Nov 29-Dec 2; Mon-Wed, 8 am-4:30 pm, Th, 8 am-7 pm

Online Nov 29-Dec 5

OPEN REGISTRATION New, Continuing, Returning and High School Contract Students (High School Contract students must register in person.)

In person Dec 6-Dec 22; Mon-Th, 8 am - 4:30 pm, Fri, closed to the public

Note: Closed for Christmas Holiday (12/23-1/2),

Jan 3-31; Mon-Th, 8 am - 4:30 pm, Fri, closed to the public

Online Dec 6-Feb 1

Note: Closed for Martin Luther King Day (1/17) and Professional Development Day (2/1)

LATE REGISTRATION New, Continuing, Returning or High School Students

In person Feb 2-10

Online Feb 2-10

OPEN ENTRY & LATE-START CLASSES Consult the “Late Start Course List” on page 90. Students must be registered before the first day of a late-start course.

WHERE & WHEN?

MAIN CAMPUS

Nov 18-Dec 22 Mon-Thurs, 8 am - 4:30 pm, Fri, closed to the public

Jan 3-31 Mon-Thurs, 8 am - 4:30 pm, Fri, closed to the public

Feb 2-10 Mon-Thurs, 8 am - 7 pm, Fri, 8 am - 4:30 pm

Feb 11 Regular business hours resume:

Mon-Thurs, 8 am -5 pm, Fri, closed to the public

MORGAN HILL AND HOLLISTER SITES

Nov 29-Dec 17 Mon-Thurs, 8 am - 6 pm, Fri, 8 am - 12 pm

Dec 20-22 Mon-Wed, 8 am-5 pm

Jan 3-31 Mon-Fri, 8 am - 5:30 pm, Fri, 8 am - 12 pm

Feb 2 Regular business hours resume:

Mon-Thurs, 8 am - 6 pm, Fri, 8 am - 5 pm

Dec 23 - 31: Closed for holiday break

Jan 17: Closed for Martin Luther King Day

Feb 1: Closed for Professional Development Day

Feb 18-21: Closed for President’s Day instructional break

April 4-8: Closed for Spring Break

May 27: Closed for Graduation

ONLINE Go to www.gavilan.edu and click on the myGAV icon.

REGISTER ONLINE!

Go to www.gavilan.edu
and click on the myGAV icon

- ✓ Register/Add/Drop Classes
- ✓ Check Class Availability and Fees
- ✓ Choose Pass/No Pass Options
- ✓ Check Prerequisites
- ✓ Print an Unofficial Transcript
- ✓ Search for classes by time, day, part of term, method of instruction and more!

Register online if:

1. You are a continuing student or have submitted an application to the Admissions & Records Office or at one of the sites at least 8 business days prior to registering.
2. You have no “holds”.
3. You are signing up for courses with prerequisites that you have successfully completed at Gavilan or have been verified by placement assessment or evaluation of official transcripts from another college.
4. You are not in “dismissed” status.

CREDIT CARDS accepted online:

American Express, Discover, MasterCard or Visa

Online Help: (408) 848-4736

Monday-Thursday, 9 am-5 pm (no Fridays, holidays or weekends)

PAYMENT DEADLINES

Students must pay ALL fees and the outstanding balance on their accounts by the deadline or they will be dropped from ALL classes.

Register Between	Last Day to Pay
Nov 18, 8:00 am - Dec 1, 2:30 pm	Wednesday, Dec 1, 2:30 pm
Dec 1, 5:00 pm - Dec 15, 2:30 pm	Wednesday, Dec 15, 2:30 pm
Dec 15, 5:00 pm - Jan 5, 2:30 pm	Wednesday, Jan 5, 2:30 pm
Jan 5, 5:00 pm - Jan 19, 2:30 pm	Wednesday, Jan 19, 2:30 pm
Jan 19, 5:00 pm - Jan 26, 2:30 pm	Wednesday, Jan 26, 2:30 pm
Jan 26, 5:00 pm and after	Day of Registration

De-Registration will occur and Registration (myGAV and in-person) will be closed from 2:30 - 5:00 pm on each deadline day.

Spring Classes pg 31

Summer Preview pg 98

You may be eligible for

Financial Aid Visit the Financial Aid office on the Gilroy campus (SC 124) or go to www.gavilan.edu/finaid on the web. Information on page 12.



Spring 2011 Semester CALENDAR

Degrees Currently Offered

by Gavilan College

Associate of Arts

Administration of Justice
Art
Business
Carpentry Apprenticeship
Child Development
Communication Studies
Digital Media
Drywall/Lathing Apprenticeship
Fine Arts
Liberal Arts *various emphasis areas*
Media Arts
Music
Physical Education
Social Science
Spanish
Theatre Arts

Associate of Science

Aviation Maintenance Technology
Biological Science
Business: Economics Option
Computer Graphics & Design
Computer Science & Information Systems
Cosmetology
Engineering & Physical Science
Health Science
Mathematics
Nursing (RN)

SPRING SEMESTER BEGINS

Aviation Maintenance Technology classes begin January 13th.

Wed, Feb 2

LAST DAY TO ADD A SEMESTER-LONG COURSE

Unless class is open entry or late-start (see list on page 90). Online registration open until 11:59 p.m. No in-person registration on the main campus after 7 pm. Use online services. All add codes must be used by Feb. 10.

Thurs, Feb 10

LAST DAY TO DROP WITH A REFUND

See page 10.

Wed, Feb 16

PRESIDENT'S DAY HOLIDAY

No day, evening or weekend classes.

Fri, Feb 18 - Mon, Feb 21

"NRS" DEADLINE

"No Record Shown". Semester-long courses dropped by this date do not appear on the student's permanent record. The "NRS" deadline for a short-term course is 30% of the class meetings.

Thurs, Mar 3

DEADLINE FOR GRADING OPTION

Last day to select the Pass/No Pass Grade option for designated, semester-long courses.

Thurs, Mar 3

SPRING BREAK

No day or evening classes.

Mon, Apr 4 - Sun, Apr 10

SPRING GRADUATION PETITIONS DUE

See a counselor to complete a petition to graduate.

Mon, April 11

"W" DEADLINE

Semester-long courses dropped by this date appear on the student's permanent record with a notation of "W" for withdrawn. The "W" deadline for a short-term course is 75% of the course meetings.

Wed, Apr 27

FIRST DAY TO FILE OFFICIAL TRANSCRIPT REQUEST

to include final grades from spring semester.

Mon, May 2

FIRST DAY TO REQUEST CSU/IGETC

CERTIFICATION Students transferring to a CSU or UC campus in the fall should submit a request for a transcript and GE or IGETC certification from the Admissions and Records Office by May 12 to ensure timely processing for 4-year transfer deadlines.

Mon, May 2

FINAL EXAMS

See page 83.

Sat, May 21 - Fri, May 27

GRADUATION

Fri, May 27 at 6:30 pm

LAST DAY OF SEMESTER

Fri, May 27

FINAL GRADES AVAILABLE ONLINE

Grades available online at www.gavilan.edu (click on the MyGAV icon)

Thurs, June 9, 2010

OFFICIAL TRANSCRIPTS AVAILABLE

Official transcripts will include spring grades as of this date.

Mon, June 27, 2010

Getting Started . . . page 4
Spring Classes . . . page 31
Summer Preview . . . page 98



OUR MISSION *In an environment that cultivates creativity, stimulates curiosity and emphasizes student learning, Gavilan College serves its community by providing high quality educational and support services that prepare students for transfer, technical and public service careers, life-long learning and participation in a diverse global society.*

ALTERNATE FORMATS:

The Gavilan College Schedule of Classes is available in alternate media formats. Contact the Disability Resource Center (408-848-4865) or the Office of the Vice President of Student Services (408-848-4738).

FORMAS ALTERNATIVAS:

El Horario de Clases del Colegio Gavilán está disponible en formato de medios alternos.

Por favor de contactar El Centro de Recursos para Discapacitados (DRC) (408-848-4865) o la Oficina del Vicepresidente de Servicios de Estudiante (408-848-4738).

ACCURACY STATEMENT: The Gavilan Joint Community College District and Gavilan College have made every reasonable effort to ensure that the 2011 Spring Class Schedule is accurate. Courses and programs that are offered, along with other information in the schedule, are subject to change without notice by the Gavilan College administration for reasons related to student enrollment, level of financial support, or for any other reason, at the discretion of the district and the college. The district and college further reserve the right to add to, amend, or repeal any of its rules, regulations, policies, and procedures, consistent with applicable laws.

Welcome to Gavilan College.



This fall saw the move of the Aviation Maintenance Technology program from Hollister to the Gilroy campus and a grand re-opening for the newly remodeled cosmetology and business buildings. The final Measure E-funded campus project is now underway with the renovation of the Social Sciences building. We continue to evaluate alternatives to expand instructional space in Hollister.

Our priority is student success. Gavilan College is part of the California Alliance for Student Success (CLASS), a commitment by twelve selected colleges. The focus is identifying strategies for keeping students in the classroom and helping them graduate. This summer we looked at what colleges have done to bring successful programs out of the pilot stage to implementation across the college. Gavilan College has formed a Learning Council of faculty, administrators and professional support staff to institutionalize a commitment to success.

Although we continue to face budget challenges, the college remains in stable fiscal condition. The spring schedule has been reduced slightly to bring offerings in line with state funding. The faculty has put many hours into evaluating the schedule to make sure that classes which are needed for program completion are available. We wish you a successful spring semester, and thank you for making Gavilan College your College of Choice.

Steve M. Kinsella

Superintendent/President
Steve Kinsella

Gavilan Joint Community College District

BOARD OF TRUSTEES

- Tom Breen, *San Benito County*
B.S., J.D., *Santa Clara University*
- Kent Child, *San Benito County*
A.A., *College of San Mateo*; B.A., M.A., *San Jose State University*
- Mark Dover, *Gilroy*
B.S., M.A., *San Jose State University*
- Laura Perry, Esq., *Morgan Hill*
A.A., *Gavilan College*; B.S., *San Jose State University*;
J.D., *Santa Clara University*
- Tony Ruiz, *San Benito County*
A.A., *Gavilan College*; B.S., M.A., *Fresno State University*
- Walt Glines, *Gilroy*
- Mike Davenport, *Morgan Hill*
B.S., *Jacksonville University, M.S., National University*
- Aaron Keller, *Student Trustee*

ADMINISTRATORS

- Steven M. Kinsella, D.B.A., C.P.A.
Superintendent/President
- Kathleen Rose, Ed.D.
Vice President of Instructional Services
- Joseph Keeler
Vice President of Administrative Services
- John Pruitt
Vice President of Student Services
- Fran Lozano
Dean of Liberal Arts and Sciences
- Sherrean Carr
Dean of Career Technical Education
- Ron Hannon
Dean of Physical Education and Athletics
- Fran Lopez
Associate Dean of Disability Resource Center
- Rachel Perez
Associate Dean of Community Development/Grants Management
- Anne Ratto
Associate Dean of EOPS/CalWORKs and CARE

CONTENTS

Spring Registration Schedule inside front

Spring Semester Calendar 1

Administrators, Board of Trustees 2

Getting Started 4

How to Use the Schedule 5

First-Time Students Guide 6-9

Matriculation (Assessment, Orientation, Counseling), MyGAV, Register Online, myDegreeWorks)

Paying for College 10-13

Fees, Parking Permits, Refunds, Online Payment Procedure and Deadlines, Financial Aid (FASFA, Ability to Benefit, Applications, Programs, Veteran Education Benefits)

Student Services 13-15

Basic Skills, CalWORKs, CARE, Career/Transfer Resource Center, Child Development Center/Preschool, Disability Resource Center (DRC), Extended Opportunity Programs & Services (EOPS), First-Year Experience, Health Services, Outreach and Recruitment, Puente Program, Student-to-Student Mediation, Transfer Services, TRIO Program

Student Life 15-16

Associated Student Body (ASB), Publications, Rho Alpha Mu/Honor Society, Clubs, Theatre Productions

High School Students 16-18

Concurrent Enrollment, Registration Checklist, Articulation Agreements, Recommended Math Placements, Transfer Institute, Puente, High Step Program

Instructional Support and Labs 18-20

STEM Grant, Bookstore, Disability Resource Center (DRC) Lab, English as a Second Language (ESL) Lab, Learning Communities, Library, Math Lab, MESA, Service Learning, Transfer Institute, GoPrint, Tutoring Services, Writing Center

Transfer 20-27

Transfer Credit, Variable Topics Courses, Transfer Services, Transfer Agreements (TAAs), Articulation Agreements, Gavilan General Education Pattern, Advanced Placement, California Articulation Numbers (CAN), Intersegmental General Education Transfer Curriculum (IGETC), Career/Transfer Resource Center, IGETC Pattern, CSU Breadth Pattern

General Information 28-29

Adding and Dropping Classes, Attendance, Advisories, Campus Safety and Crime Statistics, Course Repetition, Pass/No Pass, Letter Grade Option, Prerequisites and Co-requisites, Transcripts

Policies and Procedures 29-30

Academic Freedom, Disabilities, Discrimination, Drug Free Schools and Campuses Act, Grade Policy, Family Educational Rights and Privacy, Illegal Distribution of Copyrighted Materials, Open Enrollment, Parking, Sexual Assault, Smoke-Free Buildings, Students' Problem Resolution Process, Vocational English Skills

Spring Semester

New Spring Classes 31

Spring Classes (credit) 31-83

First Year Experience 54

Final Exam Schedule 83

Gavilan Online & SJSU Telecourses 84-85

Hollister Classes/Map 86-87

Morgan Hill Classes/Map 88-89

Early and Late-Start/Short-Term Classes 90

Noncredit Classes 91-94

Community Education Career Training 93

ROP Classes 95-97

Summer Preview 98-100

English as a Second Language (ESL) Program . . 100

Información en Español 100-103

Telephone Numbers 104

Map inside back cover

GAVILAN COLLEGE LOCATIONS

Gilroy Main Campus
5055 Santa Teresa Blvd.
Gilroy, CA 95020
408-848-4800

Morgan Hill Community Site
Gavilan College Building
17060 Monterey Road
Morgan Hill, CA 95037
408-782-2873

Hollister, Briggs Bldg.
365 Fourth St.
Hollister, CA 95023
831-636-3783

Need to print out documents?
It's easy!

GoPrint

Get 100 free prints with purchase of an ASB (Associated Student Body) card!!

Purchase either a GoPrint or ASB card and you're good to go! No need to fumble around with coins!

GoPrint cards can be purchased and reloaded at the following pay stations: The Business Skills Lab, Computer Place, Library and the Morgan Hill and Hollister computer labs.

Prints are:
\$.05 (black & white)
\$.10 (color)

- ASB cards will be issued as part of the registration process. You may pay and have your picture taken in the Admissions and Records Office or at either site.
- You may purchase your ASB card online at the time of registration only. ASB cards may also be purchased in person at the Admissions and Records office on the main campus or at either of the sites.
- Students with financial hardship can request assistance at Financial Aid, EOPS, TRIO, and MESA programs.

Getting Started

You are eligible to ATTEND GAVILAN COLLEGE if:

- ◆ You are a high school graduate or you have passed the GED or the California High School Proficiency exam
- ◆ You are 18 years of age or older
- ◆ You are currently enrolled in high school. High School students may enroll with Special Student Status by completing a High School Contract form.

ADDING & DROPPING COURSES

Students may add and/or drop courses

- **Online** (Click on the MyGAV icon at www.gavilan.edu).
- **In person** on the main campus or at the Morgan Hill or Hollister sites.

A student who stops attending a course and does not officially drop is *not* automatically dropped by the instructor and may receive a final grade of "F".

CLASS CONFLICTS

In the event of a class conflict, students must FIRST receive written approval from instructor(s) noting that they are aware there is a class conflict and how work/time will be made up. The plan must then be reviewed and approved by either the Vice President of Student Services or the Vice President of Instruction.

ADD CODES

are obtained from an instructor during late registration for closed (full) classes.

They must be used within 48 hours and no later than 11:59 pm on Thursday, February 10 online or by 7 pm in person.

EXEMPTION FROM SERVICES

In order to be exempt from assessment and orientation you must:

- ◆ have an AA degree or higher *or*
- ◆ have accumulated fewer than 12 units in transfer courses *or*
- ◆ be presently enrolled in fewer than six units.

Opt out by completing a waiver form at the Admissions & Records Office. Doing this will prevent you from participating in priority/early registration.

PLACEMENT/ASSESSMENT testing will help ensure that students are enrolled in courses that match their abilities in language and computational skills. Students must have completed the eighth grade to be eligible for assessment services. Placement scores, together with other indicators of a student's abilities, are used by counselors to determine appropriate course placements.

If you have attended another college and completed math and English courses within the past two years, you do not need Gavilan's placement assessment unless you wish to take it or it is required by your major.

See a COUNSELOR if:

- ◆ you are a first time student planning to transfer
- ◆ you are a first time student planning to obtain an AA/AS degree
- ◆ you are undecided about a major
- ◆ you are a high school contract student
- ◆ you are an academic probation student or in a "disqualified" status
- ◆ you are an international student
- ◆ you are taking 18 or more units (spring/fall) or 6 or more units (summer)
- ◆ you have completed prerequisite courses at another college
- ◆ your class has a prerequisite that was not successfully completed at Gavilan

New Students Registration Checklist

- 1) APPLICATION** File at least eight business days before taking the Placement/Assessment test. Go to www.gavilan.edu/admit and click on the link to download Gavilan's application.
- 2) PLACEMENT/ASSESSMENT TEST** Sign up by filling out and submitting the online form at www.gavilan.edu/admit/assess.html. Computers available for student use are located in the Career/Transfer Center and Library. If necessary you may still sign up at the Admissions and Records Office on the main campus.
 - a. If you have attended another college you may submit placement test scores from that college to a counselor for evaluation.
 - b. Results are available 48-72 hours after test completion at the Admissions & Records Office and the General Counseling Department.
 - c. If you do not dispute the results of your placement exams, you may register for classes without seeing a counselor.
- 3) ORIENTATION** online or in person. Sign up online at www.gavilan.edu/orientation.
- 4) REQUEST A TRANSCRIPT** from your high school if you graduated within the past five years and have not yet attended college. Request a transcript from any colleges you have attended.
- 5) SEE A COUNSELOR**
- 6) REGISTER FOR CLASSES** go online to www.gavilan.edu and click on the MyGAV icon. Create your Gavilan ID number and select a PIN. Register!
- 7) PAY FEES** in person or Online (directions on page 10.)

HOW TO USE THIS SCHEDULE

Transferable

Includes:
 CSU, UC
 CSU-GE area designation
 IGETC area designation
 Gavilan AA/AS General Education designation
 CAN #: For more information, refer to the General Education/ Course Credit Matrix on page 48 of the 2009-11 Gavilan College Catalog.

Course Number

Course Title

Discipline

Prerequisites

(Refer to the College Catalog for Advisories for most courses. See page 28 of this schedule for an explanation of Advisories, Prerequisites and Co-requisites.)

Course Reference Number

Evening & weekend Courses

Listed in gray shade

Instructional Type

LEC Lecture
 LAB Laboratory
 L/L Lecture/Laboratory

Building/ Room

Days - see legend below

Semester Units

Class Hours per week

Instructor

BUSINESS

BUS 1 Fundamentals of Business

Transferable: CSU; UC; GAV AA/AS, D2

Course Description

REQUIRED/ADVISORY: Listed at the end of the course description

CRN	Type	Room	Instructor	Hrs.	Units	Days	Begin-End
10000	LEC	BU120	ROSS Y	3.20	3.0	TR	1250P 0210P
10100	LEC	BU119	STAFF	3.30	3.0	T	0600P 0905P

Off-Campus Sites

ANZ	Anzar High School, San Juan Bautista
BROWNL	Brownell Middle School, 7800 Carmel St., Gilroy
CALAVR	Calaveras Elementary, 85 Tilton Ave., Morgan Hill
CHS	Christopher High School, 850 Day Rd., Gilroy
CRC	Centennial Recreation Ctr., 171 W. Edmundson Ave., Morgan Hill
CTC 1-4	GUSD/Gavilan Computer Technology Center on Murray Ave., Gilroy
EGLRIG	Eagle Ridge Golf Course, Santa Teresa Blvd., Gilroy
ELIOT	Eliot Elementary School, 475 Old Gilroy St., Gilroy
ELPORT	EI Portal, 277 I.O.O.F. Ave., Gilroy
ERGOLF	Eagle Ridge Golf Club, 2951 Club Dr., Gilroy
GABILN	Gabilan Hills Elementary, 901 Santa Ana Rd., Ste. 100, Hollister
GHS	Gilroy High School, 750 W 10th St., Gilroy
GIBOWL	Gilroy Bowl, 7554 Monterey Street, Gilroy
GSC	Gilroy Senior Center, 7371 Hanna Street, Gilroy
HARDIN	R. O. Hardin School, 881 Line St., Hollister
HOL	Hollister Briggs Bldg, 365 Fourth St. Hollister
HOLLCC	Hollister Community Center, 300 West St., Hollister
HOLREC	Hollister Recreation, 300 West St., Hollister
HOPE-G	HOPE - 8855 Murray Ave., Gilroy
HOPE-H	HOPE - 650 San Benito St. Suite #120, Hollister
HVME1	Hacienda Valley Mobile Estates, 275 Burnett Ave., Morgan Hill
JDA	Jovenes de Antaño, 300 West St., Hollister
JS	Jasmine Square, 16530 Monterey Rd., Morgan Hill
LOHS	Live Oak High School, 1505 E. Main Ave., Morgan Hill
MHG	Morgan Hill Community Center, 17060 Monterey Rd., Morgan Hill
OMC	Ochoa Migrant Camp
PORTHL	Portuguese Hall, 695 Seventh St., Hollister
PLY	Morgan Hill Playhouse, Monterey Highway and Dunne, Morgan Hill
ROH	R.O. Hardin Elementary, 881 Line St., Hollister
SBHS	San Benito High School 1220 Monterey St., Hollister
SBCL	San Benito County Library, 470 5th St., Hollister
SBRAT	Sobrato High School, 401 Burnett Ave., Morgan Hill
SJBCC	San Juan Bautista Community Center, 10 San Jose St., San Juan Bautista.
SOL	Solorsano Middle School, 7121 Grenache Way, Gilroy
STF	St. Francis, 7950 Church St., Gilroy
SUNNY	Sunnyslope Elementary, 1475 Memorial Dr. Hollister
SVALLY	South Valley High School, 385 loof Ave., Gilroy
VG	Village Green, 7610 Isabella Way, Gilroy
WEX	Work Experience
WM	Wheeler Manor, 651 W. 6th St., Gilroy

On-Campus Locations

APE	Adapted Physical Education
AR	Art
ATHFLDBAS	Baseball Field
ATHFLD FTBLL	Football Field
ATHFLDSOC	Soccer Field
ATHFLDSFT	Softball Field
ATHFLD TENNIS	Tennis Courts
BOB	Business Offices
BU	Business
CD	Child Development Ctr.
CE	Community Ed/Classrooms
CHP	Chapel
COS	Cosmetology
GGOLF COURSE	Gavilan Golf Course
GYGYM	Gym
GYPOOL	Gym-Pool
GYFITCNTR	Gym-Fitness Center
HOB	Health Occupations Bldg.
HR	Human Resources
HRC	Human Resources Conf. Rm
HU	Humanities
LI	Library
LS	Life Science
MA	Mathematics
MAY	Mayock House
MP	Multipurpose Building
MU	Music Hall
PB	Portable Building
PS	Physical Science
SC	Student Center
SF	Security/Facilities
SS	Social Science
TH	Theatre

Schedule Legend

M	Monday
T	Tuesday
W	Wednesday
R	Thursday
F	Friday
S	Saturday
U	Sunday
ARR	Additional weekly hours required
FEX	Field Experience
TBA	to be arranged
TV	Telecourse
Wrk Ex	Work Experience

Gray shading indicates evening and weekend classes

New!
Rent a Textbook!



Students can now save 50% or more by renting textbooks!

Go to rent-a-text.com or see bookstore for details.

First Time Students' Guide

Apply Assessment Orientation Counseling Your MyGAV Account Register for Classes MyGAV Portal Using DegreeWorks Pay for Your Classes

APPLY to Gavilan College. Allow 8 business days for your application to be processed.

APPLY for Financial Aid (if desired).

Never attended college?

Sign up for the **Placement Assessment** test no sooner than 8 business days after submitting your application. Wait 2 business days after taking the test, then...

NEW STUDENTS MUST complete the Gavilan College **Orientation** anytime after submitting your application **before meeting with a counselor.**

Establish your **MyGAV Account** no sooner than 8 business days after submitting your application. Directions on page 8.

See a Counselor for assistance with course registration.

You may choose to not participate in orientation. Doing this will prevent you from participating in priority (early) registration and prevent you from meeting with a counselor for registration assistance.

Continuing Students No new application required
Priority registration available if orientation has been completed

Returning Students New application required
Priority registration not available

Apply In-person at any of our three sites. Download an application online at www.gavilan.edu/admit

Matriculation ADMISSIONS • ASSESSMENT • ORIENTATION • COUNSELING • FOLLOW-UP

Matriculation is a series of services that Gavilan College commits to provide for you. The purpose is to help you identify your educational goals and successfully complete them.

Exemptions: Sometimes a student does not want to take advantage of the matriculation services. That is a right you have. In order to be exempt from assessment and orientation you must:

- have an AA degree or higher *or*
- have accumulated fewer than 12 units in transfer courses *or*
- be presently enrolled in fewer than six units *or*
- not plan to earn a certificate or degree.

Inform your counselor or the Admissions & Records Office if you choose to opt-out. Doing this will prevent you from participating in priority/early registration. You still have the right to use the other matriculation services. We encourage you to do so.

Assessment

Placement/assessment testing helps ensure that students are enrolled in courses that match their abilities in language and computational skills. Students must have completed the eighth grade to be eligible for assessment services. Placement scores, together with other indicators of a student's abilities, are used by counselors to recommend appropriate course placements.

Sign up by filling out and submitting the online request form at www.gavilan.edu/admit/assess.html. Computers available for student use are located in the Career/Transfer Center and Library. If necessary you may still sign up at the Admissions and Records Office on the main campus.

The assessment instruments used by Gavilan College for general assessment; the College Tests for English Placement (CTEP) and the Mathematics Diagnostic Testing Project (MDTP), are administered in English and are not intended for applicants to the English as a Second Language (ESL) program.

Sessions begin promptly at the stated time. **Check in is one half hour prior to starting time.** No one will be admitted after the session has begun.

Students must have completed the eighth grade to be eligible for assessment services.

Assessment requires:

- Valid picture ID *
- Gavilan ID number
- The Assessment Center will provide pencils and pens for students during testing
- No pagers or cell phones are allowed
- No watches allowed

* A valid picture ID includes a California Driver's License, California ID, Passport, Student Body Card, Military ID or Alien Registration Card. Contact the Assessment Office (MP100) or call 408-846-4992 if you do not have a valid ID.

All new ESL students must go through the ESL assessment process. See page 100. Todos los nuevos estudiantes de ESL deben tomar el examen de nivelación de ESL. Consulte la página 100.

Re-Assessment Sessions:

Students who have previously taken the assessment test may re-test after 30 days. You may re-assess once per semester. Stop by the Assessment Office (MP100) or call 408-846-4992 to confirm dates, times and locations.

Re-Assessment requires a copy of the student's previous test scores which can be obtained from the Counseling Secretary - SC113.

Assessment and re-assessment times and locations are subject to change. Additional times may be added. Confirm dates and locations at www.gavilan.edu/admit/assess.html or call (408) 846-4992.

Orientation

Orientation is a required component of matriculation. It provides new students with an overview of instructional programs, support services, facilities and general graduation requirements. Completion will help students avoid making course choices that might complicate and lengthen the time required to reach their educational goals. This is also a time for us to welcome you to Gavilan College and for you to have an opportunity to meet other new students and staff.

New students (never attended college) must participate in an orientation session prior to meeting with a counselor.

Orientation is completed online or in person.

Register for an Orientation online or by phone:

www.gavilan.edu/orientation: 408-848-4723.



IN PeRson Orientation ONE STOP SHOPPING!

Learn more about what the college offers: classes, degree programs, services, activities, what it will take to meet your goals and how to plan your Gavilan experience. Meet college counselors and fellow students and become familiar with the campus.

In-Person Orientation Schedule

Date	Time	Location
Wednesday, January 12	6-8 pm	Library, room 171
Monday, January 17	9-11 am	Library, room 171
Saturday, January 22	10 am-12 pm	Library, room 171
Monday, January 24	6-8 pm	Library, room 171

Counseling *New students MUST participate in an orientation session prior to meeting with a counselor.*

Gavilan College provides a staff of full and part-time professional counselors to assist students in meeting educational, career and life goals. Counseling is available to students who are uncertain about their plans for the future, who are experiencing difficulty in making important decisions, or who have any other personal or social concerns. In addition, counselors make referrals to many community agencies. Students may seek the assistance of any counselor at Gavilan. For more information or to schedule an appointment with a general counselor visit the Counseling Office - SC 113 (in the Student Center) or go to www.gavilan.edu/counsel.

See a counselor when you are:

- a first time student planning to transfer
- a first time student planning to obtain a AA/AS degree
- an undecided major
- a high school contract student
- an academic probation student
- taking over 17.99 units (spring/fall) or over 5.99 units (summer)
- have completed prerequisite courses at another college(s)
- an international student with an "F" Visa

Photo ID and Gavilan Student ID number are required to obtain counseling services.

Specialized Counselors by Program

Athletics:	848-4880	GY118
Basic Skills:	848-4776	LI 157
DRC:	408-848-4767	LI 117
EOPS/CalWORKs:	408-848-4740	LI101A
MESA:	848-4800, ext. 5606	MA117
STEM:	848-4820	LI158
TRIO:	848-4707	LI109

Counseling Schedule at the Gilroy Campus:

Counselors available during these times for registration assistance only.

January (walk-in only):

Tues	Jan 11	8 am - 7 pm	Thurs	Jan 20	8 am - 6 pm
Wed	Jan 12	8 am - 6 pm	Tues	Jan 25	8 am - 7 pm
Thurs	Jan 13	8 am - 6 pm	Wed	Jan 26	8 am - 3 pm
Tues	Jan 18	8 am - 7 pm	Thurs	Jan 27	8 am - 6 pm
Wed	Jan 19	8 am - 3 pm			

Beginning February (walk-in and appointments):

Walk-in: Mon-Fri 8:30 am - 12:30 pm
 Appointments: Mon-Thur 8:00 am - 7:30 pm, Fri 8:00 am - 3:30 pm

Student's must arrive 30 minutes prior to closing.

Counseling Schedule at the Sites:

Morgan Hill 408-782-2873

Walk-in: 11 am - 3 pm
 Evening Appointments: 4 pm - 7 pm
 (Call for appointment)

Thurs Jan 20 11 am - 7 pm
 Thurs Jan 27 11 am - 7 pm

Hollister Briggs Building 831-636-3783

Walk-in: 11 am - 3 pm
 Evening Appointments: 4 pm - 7 pm
 (Call 831-636-3783)

Tues Jan 18 11 am - 7 pm
 Tues Jan 25 11 am - 7 pm

Beginning February: Call the site for drop-in and/or appointment schedule.

Your educational plan:

You are expected to take the responsibility for scheduling an appointment with a counselor, preferably at least once a semester. The purpose of this appointment is to develop, review and update your educational plan to ensure that you are taking the appropriate courses to meet your educational goal.

Your

MYGAV Portal

- Register/Add/Drop Classes using Gavilan's Self-Service Banner
- Check Class Availability and Fees
- Choose Pass/No Pass Options and Prerequisites
- Search for classes by time, day, part of term, method of instruction
- View and print your semester schedule
- View your financial account and pay your bill with a credit card
- View and print grades and unofficial transcripts
- Update personal information
- View your Education Plan and see how close you are to completing your degree in MyDegreeWorks
- Access and manage your personal, course and school calendars.

FIRST: Go to the Gavilan homepage (www.gavilan.edu).
Click on the **MyGAV** icon.



Current Users: Log in to MyGAV

Enter your "G" number and PIN.
Click **Login** and...

...explore the **My Gav** and **Student** tabs

Secure Access Login

Gav ID:

PIN:

Having problems logging in? Click [here](#)

Get Your Gav ID and Pin
View Class Schedule
View Course Catalog

First Time Users

First Time Users: Create Your MyGAV Account

Click the link that says **Get Your Gavilan ID and PIN** and follow the steps below.

- a. Enter **your name** exactly as it appears on your application.
- b. Enter your **social security number**.
- c. Enter your **date of birth**. (mm/dd/yyyy)
- d. Click on **Get Gavilan ID and PIN**.
- e. **Write down your ID** ("G-number"). **Write down your PIN**. This is a temporary PIN. In the next step you will create your permanent PIN. If you are unable to access your Gavilan ID# and PIN call the help line at 408-848-4736, Mon-Thur, 9 am - 5 pm.
- f. Click on **Close Browser Window**. You will return to the main menu.

Get Gavilan ID and Pin

First Name:	<input style="width: 90%;" type="text"/>
Last Name:	<input style="width: 90%;" type="text"/>
SSN:	<input style="width: 30%;" type="text"/> <input style="width: 30%;" type="text"/> <input style="width: 30%;" type="text"/>
Date of Birth:	<input style="width: 20%;" type="text"/> - Month (mm) <input style="width: 20%;" type="text"/> - Day (dd) <input style="width: 20%;" type="text"/> - Year (yyyy)

From the main menu, click on **Login to MyGAV** and enter your **ID number** and **temporary PIN**.

Login Verification Change PIN

You will then receive a message that your PIN has expired. Enter the old/temporary PIN number first, then choose a new six digit number that you will remember and enter it on the next two lines.

Either you are a first-time user or your PIN has expired. You will have to change your PIN before logging in.

Re-enter Old PIN: (First-time users: None)

New PIN: (Pin must be 6 digits)

Re-enter new PIN:

On the next screen, **enter a security question**. It should be something that has an answer that does not change and you will always know (for example,

‘What town was my sister born in?’ On the next line, enter the answer.

Once you submit this question and answer, you will be welcomed to your personalized Banner account!

Login Verification Security Question and Answer

If you forget your PIN, you can reset it yourself without calling for assistance. Enter your personal Security Question, along with the Answer. This will help you to remember your answer, limit it to 30 characters. You can change your security question and answer, as often as you want.

Enter Question:

Answer:

How to Register for Classes

New students must file an application at least 8 business days prior to registering.

1. Go to the Gavilan homepage (www.gavilan.edu).



Click on the **MyGAV icon**.

2. **Log in to MyGAV.** Enter your **"G" number** and **PIN**. Click **Login**.

3. On the **Main Menu** page, select the **Student Tab**.

4. On the **Student** page, click in the **Gavilan Self-Service Banner** box.

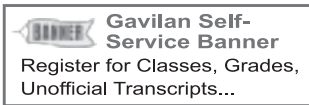

6. On the **Main Menu** page, select **Student**.

7. On the **Student Menu** page, select **Registration**.

8. On the **Registration** page, click on **Add or Drop Classes**.
 - ESL students: All new ESL students need to go before registering.
 - Search for Classes: View the current schedule of classes.
 - Select Term: Add or Drop Classes for the selected term.
 - Add or Drop Classes: View the current schedule of classes.

Registration

ESL students: All new ESL students need to go before registering.

Search for Classes
View the current schedule of classes.

Select Term
Add or Drop Classes for the selected term.

Add or Drop Classes
View the current schedule of classes.

9. On the **Registration Term** page, select the **term** from the drop down list for which you will enroll (e.g. Fall 2010).

Select Term

Select a Term: | Spring 2011

Submit

10. On the **Registration** page, select **Add or Drop Classes**.

11. On the **Add or Drop Classes** page, enter the **CRNs** of the courses you wish to register for and select **Submit Changes**.

Add or Drop Classes

To add a class, enter the Course Reference number in the Add Classes section. To drop a class, enter the Course Reference number in the Drop Classes section.

Add Classes Worksheet

CRNs

Submit Changes Class Search Reset

9. If **Status==Web Registered**** then you have successfully registered for the class(es).

Add or Drop Classes

To add a class, enter the Course Reference Number in the Add Classes section. To drop a class, enter the Course Reference Number in the Drop Classes section.

Current Schedule

Status	Action	CRN	Subj	C
Web Registered on Nov 29, 2011				

10. To pay for the class(es) you have registered for, go to the bottom of the page and select **Registration Fee Assessment** and you will see your account balance information and payment instructions.

Schedule a counseling appointment to develop your individualized, comprehensive educational plan.

To schedule a counseling appointment visit the Counseling Office - SC 113 (Student Center) or go to www.gavilan.edu/counsel.

my DegreeWorks

Your account will provide 24/7 online access to:

- View your progress toward a Gavilan degree or certificate.
- Keep track of courses you must take to complete your degree or certificate.
- Check other degree options without any commitments.
- View and print your educational plan.
- View Notes from the counseling and administrative offices.
- Use a GPA calculator to determine your term or graduation GPA.

The screenshot shows the DegreeWorks interface for a student named John Doe. It displays the student's name, degree program (Administration of Justice AA), last audit date (10/06/2010), and last refresh time (Today at 12:15 am). Below this, there are tabs for Ed. Plan, Notes, Petitions, Exceptions, GPA Calc, and Advis. The 'Student View' tab is selected, showing a 'Gavilan College Unofficial Degree Audit' for student ID G00123456, catalog year Fall 07- Summer 08, and an overall GPA of 2.864. The audit shows progress towards requirements, including Law Enforcement Courses and General Education Requirements. A legend explains the status of various requirements, such as 'Complete', 'Complete except for classes in progress', and 'Transfer Class'. A list of courses is shown with checkboxes for selection, including 'A1 Oral Communication', 'A2 Written Communication', 'A3 Reading', 'A4 Mathematics', and 'A5 Art/Foreign Language/Lit/Phys'. The interface also includes a 'Requirements' section with a table of course requirements and a 'Legend' section with checkboxes for various requirement statuses.

Paying for College

Pay fees in person on the main campus, at either site or online at www.gavilan.edu. Click on the MyGAV icon.

In Person: cash, check, Mastercard, Visa

Online: American Express, MasterCard, Visa or Discover Card

Basic Fees

Per unit fee (California resident)	\$26
Per unit fee (non-resident)	\$224
Health Fee: fall/spring	\$15
summer	\$5
Campus Center Use Fee (fall & spring only)	\$1 per unit to a maximum of \$5
Student Representation Fee	\$1
Student Identification Card Fee	per semester \$6

Spring Fee Schedule

TOTALS INCLUDE: \$26 per unit Enrollment Fee, \$198 Non-Resident Fee (if applicable), \$15 Health Fee, \$1 per unit Campus Center Use Fee (to a maximum of \$5), \$6 Student ID/Discount Card and \$1 Student Representation Fee.

# of Units	California Resident	Non Resident Out-of-State
0.5	35.50	136.50
1.0	49.00	247.00
1.5	62.50	359.50
2.0	76.00	472.00
2.5	89.50	584.50
3.0	103.00	697.00
3.5	116.50	809.50
4.0	130.00	922.00
4.5	143.50	1034.50
5.0	157.00	1147.00
5.5	170.00	1259.00
6.0	183.00	1371.00
6.5	196.00	1483.00
7.0	209.00	1595.00
7.5	222.00	1707.00
8.0	235.00	1819.00
8.5	248.00	1931.00
9.0	261.00	2045.00
9.5	274.00	2155.00
10.0	287.00	2267.00
10.5	300.00	2379.00
11.0	313.00	2496.00
11.5	326.00	2603.00
12.0	339.00	2715.00
12.5	352.00	2827.00
13.0	365.00	2939.00
13.5	378.00	3051.00
14.0	391.00	3163.00
14.5	404.00	3275.00
15.0	417.00	3387.00
15.5	430.00	3499.00
16.0	443.00	3611.00
16.5	456.00	3723.00
17.0	469.00	3835.00
17.5	482.00	3947.00
18.0	495.00	4059.00

Student Identification(ASB)/Discount Card

ASB cards will be issued as part of the registration process. You may pay and have your picture taken in the Admissions and Records Office or at either site. Students who register online and opt not to purchase an ASB card at the time of registration may purchase one at a later time in person at the Admissions and Records office on the main campus or at either of the sites. Students with financial hardship can request assistance at Financial Aid, EOPS, TRIO, and MESA programs.

The purchase of a **Associated Student Body Card** benefits both the individual student and the college at large. The fees are budgeted by the ASB to develop and support campus activities, educational programs, speakers, and cultural events. For more information on the many benefits of an ASB card, see Student Life on page 15.

Book and Materials Costs Reference H. R. 4127

Colleges are required to disclose the International Standard Book Number (ISBN) and retail price of required or recommended text books and supplemental materials for each course. This information is available on at www.gavilan.edu/bookstore/index.html.

California Nonresident Tuition Fee Exemption (AB540)

as required by California law, provides an exemption from payment of non-resident tuition for eligible non-immigrant students. To be eligible, a student must have attended a California high school for three full years and have graduated from a California high school or have received the equivalent of a California diploma (GED, CHESPE). The exemption does not grant residency status and the qualifying student may not be eligible for state aid programs such as BOG, EOPS or federal financial aid. The student must sign an affidavit affirming that he or she has filed or will file an application with INS to legalize his or her immigration status as soon as he or she is eligible to do so. Contact the Admissions & Records Office for more information.

Parking Permits Required only on the Gilroy campus Monday-Friday. Purchase parking permits at the Admissions and Records Office.

Day Permit (7 a.m. - 10 p.m.)	\$40
Day Permit with TANF/AFDC/SSI or Financial Aid	\$20
Evening Permit (3 p.m. - 10 p.m.)	\$20
Summer	\$20

One-day permits may be purchased for 75 cents from the coin-operated machines located in parking lots A, E, H and at the south entrance to campus. Exact change is required.

Refunds Students must drop semester-long courses no later than Feb. 16 in order to receive a refund. Short-term courses must be dropped before 10% of the course meetings have passed. For one- or two-day courses, this date will occur before the start of the course.

Refunds of less than \$10 will remain on the student's account as a credit unless the Admissions and Records Office receives a Request for Refund form from the student.

Refund checks are mailed. Be sure your address is current (Online at www.gavilan.edu). Check your MyGAV account) to ensure prompt delivery.

Student Health Fees Gavilan College is required to maintain health services and accident insurance for all students enrolled in credit classes. These services are covered by the health fee.

Student Representation Fee The Student Representation Fee is a \$1 per semester fee that students approved through a student body election. The student government (ASB) oversees and uses the fees to lobby and advocate for student issues and concerns at the state level. It also supports opportunities for students to attend leadership conferences on issues related to advocacy. Those students who do not wish to support these activities may request a refund directly from the ASB.

Courses With Additional Materials Fees

Payable at registration

COURSE	DESCRIPTION	FEE
AH 52	MED-SURG NURSING	\$100.00
AH 54	MED-SUR/PEDI.NURSE	\$100.00
AH 56	COMPENSATORY NSG	\$100.00
GUID 1	SELF ASSESSMENT	\$12.00
PSYC 5	SELF ASSESSMENT	\$12.00

Payable to instructor or additional materials required:

COURSE	DESCRIPTION	FEE
COS 200	BEGINNING COSMETOLOGY KIT includes cosmetology kit, manikin, and uniform	\$800 (approx.)
COS 201	INTERMEDIATE COSMETOLOGY Students must purchase supplies. Does not include books and classroom materials.	\$200 (approx.)
COS 202	ADVANCED COSMETOLOGY Students must purchase supplies. Does not include books and classroom materials.	\$200 (approx.)
PE 20	BOWLING	\$1.50 per session

Don't let this happen to you!

All students will be required to pay for their classes in full by the posted payment deadline nearest to the date of their registration. For some students this may be the same day that they register. Please refer to the Payment Deadline chart below, or online at my.gavilan.edu.

Even those students who receive financial aid will be required to pay some minimal fees (some as low as \$1.00) before the payment deadline or risk being dropped from ALL classes.

For those students who add classes *after* the initial registration, you **MUST** check your account balance. If you owe additional fees, you must pay those before the payment deadline or you will be dropped from ALL your classes, even those you registered for earlier.

FAILURE TO PAY BY THE DEADLINES BELOW WILL RESULT IN YOUR BEING AUTOMATICALLY DROPPED (DEREGISTERED) FROM ALL OF YOUR CLASSES!

If you are unsure if you qualify for aid or the amount you will be expected to pay in fees upon registration, visit the Financial Aid Office on the main campus or view your financial aid status on MyGAV.

PAYMENT DEADLINES	
Student must pay ALL fees and the outstanding balance on their accounts by the deadline or they will be dropped from ALL classes!	
Register Between	Last Day to Pay
Nov 18, 8:00 am - Dec 1, 2:30 pm	Wednesday, Dec 1, 2:30 pm
Dec 1, 5:00 pm - Dec 15, 2:30 pm	Wednesday, Dec 15, 2:30 pm
Dec 15, 5:00 pm - Jan 5, 2:30 pm	Wednesday, Jan 5, 2:30 pm
Jan 5, 5:00 pm - Jan 19, 2:30 pm	Wednesday, Jan 19, 2:30 pm
Jan 19, 5:00 pm - Jan 26, 2:30 pm	Wednesday, Jan 26, 2:30 pm
Jan 26, 5:00 pm and after	Day of Registration
De-Registration will occur and Registration (MyGAV and in-person) will be closed from 2:30 - 5:00 pm on each deadline day.	

We are anticipating that more students than ever will apply to Gavilan College and we expect classes to fill quickly. For best selection, register early, but be prepared to pay by the payment deadline.

Payment of fees can be made in the following ways:

Go to your MyGAV Online Account. You can pay with American Express, Discover, Mastercard or Visa (including debit cards.)

In Person at the main campus or at the Hollister or Morgan Hill sites.

By Mail Include your Gavilan ID number on the check and mail to:

Gavilan College Admissions and Records Office
 Attn: Diane Sousa, Student Accounts
 5055 Santa Teresa Blvd.
 Gilroy, CA 95020

Make a Payment in your MyGAV Account

- Go to the Gavilan website <http://www.gavilan.edu> and click on the MyGAV link.



- Log in to MyGAV. Enter your "G" number and PIN. Click Login.

- On the Main Menu page, select the Student Tab.

- On the Student page, you will see a My Fees box. If you owe fees for a term, the amount will show and an icon depicting two credit cards will appear to the right of the amount.

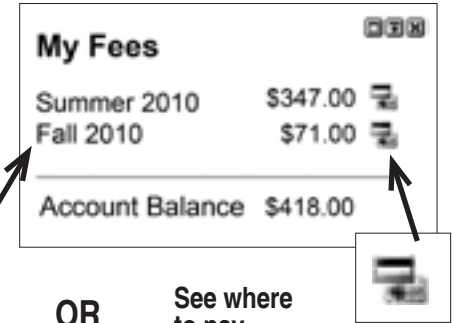

- See what you owe.

Click on the term and a **Account Summary by Term** window will open.

OR

See where to pay.

Click on the icon and a **payment box** will open.

Enter the amount you wish to pay and click on **Submit Payment**.

- Enter your credit card information and **Click on Confirm**.

Payment Method: You can pay with American Express, Discover, Mastercard or Visa (including debit cards).

- Check out the **other useful links** at the bottom of the page:

Overall Financial Aid Status
 Financial Aid Award Information Menu
 Statement and Payment History

Applying for Financial Aid

Financial assistance with college expenses is available for students of all incomes.



FINANCIAL AID OFFICE

Room SC 124 Email finaid@gavilan.edu, visit www.gavilan.edu/finaid or check the student tab at my.gavilan.edu.

Open: Mon-Thurs: 8 am - 5 pm, Fri.: closed to the public.

Evening hours: Hours are extended during peak registration periods.

Gavilan College participates in several financial aid programs that are designed to provide assistance to students with documented financial need. This aid is provided from several sources: federal, state and private agencies.

FAFSA Requirements:

Financial aid applicants must:

- demonstrate need according to the guidelines of each program.
- be a U.S. citizen or eligible non-citizen.
- be in good standing on a federal student loan (not in default) or not owe a refund of student financial aid.
- demonstrate ability to benefit from higher education
- be a regular student in an eligible program enrolling for the purpose of obtaining a degree or certificate.
- be registered (or formerly registered) with Selective Service (males only).
- maintain satisfactory academic progress.

Ability to Benefit

NEED FINANCIAL AID BUT HAVE NO HIGH SCHOOL DIPLOMA?

Federal regulations require students who do not have a high school diploma, General Educational Development (GED) certificate, or California High School Proficiency Exam (CHSPE) and who are applying for financial aid, to take an Ability to Benefit assessment. If you have a high school diploma (or equivalent) from another country you are exempt.

THERE ARE THREE METHODS TO DEMONSTRATE ABILITY TO BENEFIT:

1. **ASSET Testing Schedule for Native English Speakers**
The Ability to Benefit schedule can be found on the Assessment web page. Go to www.gavilan.edu/admit/assess.html. **Additional information below.**
2. **CELSA (Combined English Language Skills Assessment)**
Students with limited English language skills who are enrolled in English as a Second Language (ESL) classes and do not have a high school diploma or GED and are applying for Financial Aid must take the CELSA assessment. CELSA testing is offered one day per month. Call the Financial Aid Office for a referral.

SATISFACTORY ACADEMIC PROGRESS (SAP) POLICY

The Gavilan College Financial Aid Office is required to measure your academic progress toward a certificate, associate, or transfer degree program. If you are not pursuing one of these programs, you are not eligible for financial aid. Your progress will be reviewed at least once per academic year.

If you had extenuating circumstances for your last term at Gavilan College and were placed on disqualification, you may submit an Appeal and SAP Quiz to the Financial Aid Office for consideration.

Additional information below.

Additional Information for ASSET and CELSA test takers: Sign up for testing sessions through the Financial Aid Office: 408-848-4727 (SC124). Sessions begin promptly at the stated time. **Check in is one half hour prior to starting time.** No one will be admitted after the session has begun.

Students must provide a valid picture ID*, Gavilan ID number, a copy of his or her class schedule and the yellow referral slip from the Financial Aid Office to be admitted to the testing room.

Times and locations subject to change and additional times may be added to the schedule. Confirm time and location with the Assessment Office (MP100 - 408-846-4992) at least two business days prior to your scheduled appointment.

* A valid picture ID includes a California Driver's License, California ID, Passport, Student Body Card, Military ID or Alien Registration Card. Contact the Assessment Office (MP100) or call 408-846-4992 if you do not have a valid ID.

- 3 **Successful Completion of 6 Degree Applicable Units at Gavilan College** If you have successfully completed at least 6 units of degree applicable units, you have demonstrated the ability to benefit. Please make an appointment with a Gavilan College academic counselor for certification of unit completion.

Applications

FAFSA (Free Application for Federal Student Aid) determines your eligibility for federal/state grants, work study, and loans as well as the fee waiver for methods B and C. The FAFSA can be completed through paper application or online at www.fafsa.ed.gov. Be sure to add the Gavilan school code of 001202 so that the Financial Aid Office can receive your processed FAFSA. Complete the:

- 2010-11 FAFSA: if you will attend the fall '10, spring '11 or summer '11 terms

Scholarship Applications: The Financial Aid Office maintains a scholarship website where upcoming scholarship opportunities are posted, including scholarship applications. For current scholarship opportunities, visit us online at <http://www.gavilan.edu/finaid/scholarships/index.html>.

Financial Aid Programs

BOG FEE WAIVER: Board of Governor's Fee Waiver Program waives mandatory enrollment fees for eligible California residents. For complete details on three different methods to qualify for the BOG Fee Waiver, visit us at <http://www.gavilan.edu/finaid/apply/waiver.html>.

FEDERAL AND STATE GRANTS AVAILABLE AT GAVILAN COLLEGE:

- Federal Pell Grant
- Federal SEO Grant
- Federal Work Study Grant
- Cal Grant (B and C)
- Chafee Grant

FEDERAL WORK-STUDY GRANT: Provides Gavilan College students with part-time employment while gaining valuable work experience. To be considered for federal work study, students are required to file the 2010-2011 FAFSA, indicate interested in Work Study on question 31 of FAFSA, meet program requirements, and have financial need. Funding for Federal Work Study program is limited, students are encouraged to file the 2010-11 FAFSA by 4/30/2010 to be considered for FWS.

STUDENT LOANS: Gavilan College participates in the Federal Direct Student Loan Program. If you are interested in applying for a student loans, contact the Financial Aid Office.

SCHOLARSHIPS: Scholarships are awarded on the basis of academic achievement and/or financial need. Eligibility varies and is set by the scholarship donor. Private scholarship applications with various deadlines throughout the

school year are available on the Financial Aid website. See the Financial Aid website at www.gavilan.edu/finaid. We recommend you research scholarships several times per semester as new scholarships are announced throughout the academic year as they become available.

Veteran Education Benefits

Welcome back veterans! Gavilan College offers special assistance to veterans and dependents of disabled veterans.

Pre-priority registration is granted to any member or former member of the Armed Forces of the United States who is within two years of leaving active duty. For more information consult a counselor or the Financial Aid Office.

Gavilan College recognizes credit and grants credit to veterans and reservists for service and training completed in the Armed Forces. Gavilan College reports as credit for prior training only those prior units that are required for the student's current objective at Gavilan College.

Students having questions pertaining to eligibility for benefits, application procedures and other veteran matters should contact the Veteran Certifying official in the Financial Aid Office (SC124) or call 408-848-4734. We are open Monday - Thursday 8 am to 5 pm.

Below is list of various chapters for veteran education benefits:

- Chapter 30 Montgomery GI Bill
- Chapter 31 Vocational Rehabilitation
- Chapter 33 Post 9/11 GI Bill
- Chapter 35 Dependents Educational Assistance
- Chapter 1606 Montgomery GI Bill – Selected Reserve
- Chapter 1607 Reserve Educational Assistance Program (REAP)

Post 9/11 GI Bill: Only active duty service performed after 9/11/2001 may be considered for determining eligibility for this new benefit. To be eligible, a service member or veteran must have served at least 90 days on active duty. However individuals honorably discharged for a service-connected disability who served 30 continuous days after 9/10/2001 may also establish eligibility.

Apply for benefits online: <http://vabenefits.vba.va.gov/vonapp/main.asp>

Visit us: Bring DD214 to VA Certifying Official in the Financial Aid Office. Bring any academic transcripts from previous institutions for development of an Ed Plan. To schedule an appointment with a Gavilan College counselor to develop and Ed Plan, please visit the Counseling Office - SC 113 (in the Student Center) or go to www.gavilan.edu/counsel.

The VA Certifying Official will require an Education Plan in order to certify benefits.

LOOK US UP ONLINE AT WWW.GAVILAN.EDU/FINAID/

Selective service verification of enrollment at www.sss.gov

Apply for PIN at: www.pin.ed.gov

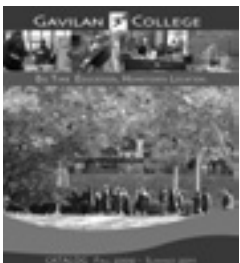

The **College Catalog** contains a complete description of all Gavilan College courses, student policies, and services. It can be purchased for \$4.00 at the bookstore or viewed online at www.gavilan.edu/catalog

Student Services

Basic Skills students are those who assess into pre-collegiate, non-transferable levels of English and/or Math as well as ESL courses. Support and services are available to ensure they have every opportunity to be successful with their academic goals.

Students who require these pre-collegiate course(s) are identified and assisted with obtaining appropriate services and resources, on and off campus, that may enable them to become academically successful and on track to achieving their goals. Students are referred to the excellent categorical programs on campus such as DRC, EOPS, MESA, Puente and TRIO and those who do not qualify are offered one-on-one counseling services with a designated counselor.

In-class workshops on topics such as study skills, time management, math “fear no more” and goal setting provide students with practical tools and strategies to be successful, and individualized counseling and an “early alert” system help to identify and resolve student issues early.

The Basic Skills Counselor strives to empower students and fosters student success and academic goal achievement within a nurturing, non-judgmental, confidence building environment.

CalWORKs serves students who receive public assistance to become self-sufficient through the provision of education, employment and supportive services. The occupational programs for CalWORKs students are linked to the demands of the local labor market and can assist students with a career track that will lead to a family-supporting income. The support services that CalWORKs provides include academic, personal and career counseling, textbooks, employment assistance and job placement and serves as a liaison with county departments of social services.

The CalWORKs staff is friendly and supportive and will work with students to help them reach their goals. The office is located in L101 A, next to the library and is open Monday through Friday, 8 a.m. to 5 p.m. Interested students may call 408-848-4813.

The Cooperative Agencies Resources for Education **CARE** is a special program designed to assist single parents who attend or would like to attend Gavilan College. CARE is a joint effort among the Department of Social Services, EOPS and Gavilan College. To be eligible for CARE, a student must be at least 18 years of age, head of household single parent/grandparent receiving cash assistance from the Department of Social Services, have at least one child under 14 years of age and be eligible for EOPS.

Services provided include: counseling, priority registration, academic tutoring, financial assistance with transportation, books, supplies, grants and other support services.

For additional information, call 408-848-4790 or visit the EOPS office located in LI101 A/B.

Career/Transfer Resource Center The Career/Transfer Resource Center offers numerous resources to help in making career decisions, plan for college, obtain specialized training or enter an academic or vocational program at Gavilan College. Career-related services are available to currently enrolled students, prospective students, faculty, staff, and community members. The computerized career guidance program, EUREKA, aids in researching occupations, identifying which colleges offer specific majors, and investigating financial aid and scholarships.

Visit the Career/Transfer Center and log on to Career Connections, a job search website for employers and employees. We are located in the Student Center, SC 101. Make an appointment with the Career Center Specialist at the SARS kiosk in the Student Center or call 408-848-4818.

The **Child Development Center/Preschool** provides care for preschool children in two state-funded programs for families whose monthly income meets eligibility criteria. In addition, a fee based preschool program is available to all parents. These programs serve children with disabilities and special needs as well as children who are limited or non-English speaking.

The Center is located above parking lot C and is open Monday-Friday. For more information call 408-848-4815.



Health Insurance

For Students

Affordable year-round insurance is now available for community college students enrolled in a minimum of 6 units!

\$200 deductible per year (\$100 when referred by Student Health Services)

Visit the doctor of your choice.

Benefits include: hospitalization, emergency room visits, surgery, doctor's visits, treatment for mental and nervous conditions, prescription drug coverage, toll-free Nurse Advice Line.

For more information call 1-800-367-5830 or visit studentinsuranceagency.com. Click on Domestic Plans.

Sponsored by the Community College League of California

Disability Resource Center (DRC) provides a variety of services and classes in an effort to equalize educational opportunities for students with disabilities as they move toward their educational or vocational goals.

Services include: Academic, Career and Vocational Counseling • Registration Assistance • Learning Skills Assessment • Specialized Tutoring • Vocational Preparation and Job Placement • Mobility Assistance • Note Taking • Test Taking Facilitation • Sign Language Interpreting • Real Time Captioning • Alternate Media Services • Assistive Computer Technology and Training

DRC CLASSES OFFERED:

Guidance Courses:

Guid 530	Job Readiness
Guid 557	Learning Skills Evaluation
Guid 558	Learning Skills Laboratory
Guid 560	Individual Learning Skills Development
Guid 562	Directed Study Lab in Pre-Algebra
Guid 563	Directed Study Lab in Algebra
Guid 565	Directed Study Lab in Intermediate Algebra

Adapted Physical Education:

APE 34/534	Adapted Aquatic Exercise
APE 35/535	Adapted Swimming for Total Fitness
APE 36/536	Adapted Physical Education
APE 38/538	Adapted Cardiovascular Conditioning and Training

Computer Science Classes:

CSIS 570	Computer Access Evaluation
CSIS 571	Computer Assisted Instruction
CSIS 572	Adaptive Computer Basics

Vocational Preparation: These programs are offered for students with developmental disabilities at three sites: Gavilan College, HOPE in Gilroy and HOPE in Hollister.

Students requiring accommodations or arrangements because of hearing, visual, or other disabilities should contact their instructor, counselor, or the Adapted Services Specialist at the Disability Resource Center located in LI 117. For more information call 408-848-4865.

Extended Opportunity Programs & Services (EOPS)

provides student support services designed to increase access, retention and transfer of students with social, economic and educational challenges.

The EOPS Program services include:

Counseling: academic, career and personal counseling • transfer assistance • field trips to major universities • community agency and emergency referrals

Financial Assistance: book vouchers

Specialized Workshops for facilitating student success

Other Services: student computer center • book lending library • priority registration • EOPS club

The EOPS office is located in L101 A & B in the library and is open Monday through Friday, 8 a.m. to 5 p.m. Students who are interested may call 408-848-4740.

First-Year Experience Gavilan College offers a program for "first-time," new students who want to strengthen their reading, writing and study skills while they become familiar with the campus and its resources. Teachers and counselors work together to help students develop connections between the courses and their college experience. The goal is to help students build a strong foundation and place them on the road for college success. See classes on page 54.

Health Services Gavilan College provides a full-time faculty/college nurse who provides health services, health information, health education events, health counseling and referrals in a quiet, confidential setting.

Students receive confidential, personal health counseling for a variety of health concerns. Health Services provides first aid treatment, blood pressure screening, tuberculin skin testing for students, HIV testing referrals, condoms and over-the-counter medications such as aspirin. Pamphlets and classes are available on nutrition, hepatitis, stress management, AIDS, suicide and other health topics. Health information is provided in small group settings. Referrals for health conditions including alcohol and drug intervention are available. Health Services provides first aid kits throughout the campus and at the satellite sites, responds as a member of a team to campus emergencies on the main campus and provides information regarding outside health insurance for the college student.

Health Services is a comprehensive "one stop" center for a variety of health services located in the Admissions Building (SC 118.) Services are free and available Monday - Friday on the main campus in Gilroy. For additional information call 408-848-4791.

Outreach and Recruitment services are designed to familiarize the community with the variety of programs and services available at Gavilan College. We will schedule tours of the campus or visits to a specific department, or provide information on academic, vocational and transfer opportunities. Outreach and Recruitment will also arrange for representatives from Gavilan to make presentations at your school or event.

For further information or to schedule a workshop, presentation or tour, please contact Outreach Services at outreach@gavilan.edu or call (408) 846-4993. Office location: BU123.

The **Puente Program** assists educationally underserved students who plan to transfer to four-year colleges and universities, earn degrees and return to the community as leaders and mentors to future generations. Puente is open to all students.

English Instruction: Puente students take two consecutive writing classes, English 250 (Practical Writing) and English 1A (Composition). These classes provide a supportive and stimulating environment for Puente students to build confidence in their writing skills through an exploration of the Mexican American/Latino experience.

Counseling: Puente students work closely with their Puente counselor until they graduate, exploring career options, developing an academic educational plan and identifying lifetime goals. Students visit University of California and California State University campuses and attend an annual Puente student transfer conference. All Puente students are also required to enroll in Guidance 6 (Life Skills for Higher Education) and Guidance 1 (Self-Assessment and Career Development).

Mentors: Each Puente student is matched with a mentor from the business or professional community. Mentors share with students their personal, academic and career experiences, and provide a window into "real-life" work environments. The network of trained Puente mentors provides many resources for the Puente students, their families, their colleges and their communities. If you are interested in more information please visit SC 105 or call 408-848-4807.

Student-to-Student Mediation services provide students with an opportunity to problem-solve together in a safe environment. Trained student mediators will work with two or more students who are in conflict to reach mutually agreeable solutions. Mediation services are free and confidential.

Students wishing to become mediators can register for Introduction to Conflict Resolution (Psychology 6).

To obtain mediation services for a dispute on campus, contact the Counseling Department at 408-848-4723.

Transfer Services See Career/Transfer Resource Center ad on page 23.

TRIO, Student Support Services is a federally funded program designed to assist 160 first generation, low-income, and/or disabled Gavilan College students as they prepare to obtain a two-year degree and/or transfer to a four-year university. TRIO provides additional services such as academic counseling, book and laptop lending programs, cultural and social activities and university visits.

TRIO is committed to increasing graduation and transfer rates by creating a “sense of place” for those students who sometimes feel isolated and disconnected during their college experience. If you are interested in more information please visit the TRIO Program in the Library (L1109) or call 408-846-4981.



Curbside Espresso Bar.

Student Life

The **Associated Student Body (ASB)** is the official student organization on campus and provides the majority of student input and recommendations on critical campus issues to faculty, staff, administration and the Board of Trustees.

The Student Senate is a representative body of students who meet weekly to plan, implement and evaluate college activities and services that meet the needs of Gavilan College students. Any student who meets the requirements of the ASB's by-laws may become a voting member of the Student Senate. The elected and appointed officers provide a liaison between the students and academic departments and student services. The variety of leadership positions allows for different levels of involvement so that students can balance their academic and extracurricular loads effectively.

The political and practical leadership skills that students develop through the ASB are supplemented through a leadership course offered through the Political Science and Psychology Departments (POLS 27; PSYC 27). The curriculum includes practical skills that are applicable to college-related opportunities and other professional and personal environments. The curriculum is an interdisciplinary approach to contemporary leadership. This is an elective course that is transferrable to the CSU system and meets a GE requirement for the Gavilan College A.A./A.S. degree. Although the UC system does not accept the units for the class, it gives added consideration to those students who have been involved in student government and other college governance activities. Employers also look favorably upon a student's involvement in college leadership.

The benefits of buying an ASB Student Body Card are many. Revenue supports social and cultural activities on campus and provides the purchaser with free admission to athletic events, discounts at cultural events and free bluebooks and scantrons (testing supplies) in the bookstore. Community-wide businesses offer discounts to card holders such as reduced movie admissions, restaurant, gym, museum, computer and software discounts. ASB cards can be activated as library cards and come with 100 free prints. Visit the ASB office in the Student Center - room 158 or call 408-848-4777.

Publications **The Gavilan Press**, an independent student newspaper, gives students a real world journalism experience, training in traditional and digital tools, and a public forum for their ideas and opinions. The newspaper has covered events, issues and people that shape, reflect and define the college and the world since 1967. The Gavilan Press is also available online at www.gavilanpress.com. Call 408-848-4837 for more information.

Rho Alpha Mu - Honor Society is the Gavilan College chapter of Alpha Gamma Sigma, the California Community College Honor Scholarship Society. Its purpose is to recognize student scholarship, contribute to the social and cultural life of the campus

- Ambassadors
- Aneme
- Chi Sigma Lota (Administration of Justice)
- Cheerleading
- CDC Parenting Club
- Christian Fellowship
- Communications Club
- COSMO
- Digital Media
- EOPS Club
- Gavilan Burners
(Wheelchair Basketball Club)
- Gavilan Music
- The Gavilan Press/Student Newspaper
- GavTV
- Health Promotion
- Inception Literary Club
- International Club
- Knit Wits
- Latina Leadership Network
- MANO (Men's Academic Network Organization)
- MESA (Math Engineering Science Achievement)
- OUT
- Parent's Club
- Physician Assistants Club
- Rho Alpha Mu
- Science Alliance
- TADA/Theatre Arts
- Teachers For Tomorrow

ASB CLUBS

For more information call 408-848-4777.



A variety of clubs and organizations have been established to provide opportunities for students to participate in scholastic, social, political, cultural and recreational pursuits. Club activities are coordinated and supported through the Student Senate. Students are encouraged to start clubs if they have a particular interest not represented currently on campus.

and to provide and promote active involvement with the larger community through voluntary community service activities. Membership is open to all those with at least a 3.0 grade point average. There are a number of financial award possibilities for members in good standing. For more information call 408-848-4897.

Theatre Productions The Gavilan College Theatre offers a range of plays, including childrens' plays, musicals and Shakespearean productions. In addition to performing on stage, students learn backstage and technical production skills. For more information visit www.gavilan.edu/theatre.

TADA Productions - The Gavilan ASB Theatre Club sponsors several social and cultural events during the school year including: *Fiesta Mexicana*, a Folklorico Concert; *Historias de mi Madre* a Community Solutions event for Domestic Violence Awareness month; *One Night Stand(s)*, fall & spring stand-up workshops and Comedy Night(s); and other student generated performances.

In 1985, the Gavilan College **Summer Theatre Arts Repertory (STAR)** Program was created to give Gavilan College Theatre Arts students an opportunity to share their passion for the performing arts with South County youth. Students from the academic program serve as STAR leaders, often directing and producing plays. The Theatre Arts Program provides academic credit, production experience, and the opportunity for individual growth through the arts. For more information, call 408-612-2057 or visit www.gavilan.edu.star.

High School Students

Concurrent Enrollment Procedures

Students whose age or class level is equal to grades 9-12 may attend Gavilan College as part-time or summer session students for advanced scholastic, vocational, or physical education courses in accordance with the following procedures:

A **Special Student Status Contract Form** is required prior to registering for classes. A new form must be completed each semester. The form is available in local high school counseling offices, from the Gavilan College Admissions & Records Office and is included in this schedule. The form is also available online at http://www.gavilan.edu/admit/documents/Gavilan_HighSchool_ContractForm.pdf.

Students enrolled in a public or private high school will be limited to a maximum of 6 transfer-level units for fall or spring semesters and 5 during the summer term (certain exceptions may be available for students enrolled in the TJ Owens Early College Academy). Students in good standing, with a minimum 2.0 GPA, must submit an application for admission, a current transcript, complete the placement assessment, and have written approval of a parent or legal guardian, a high school counselor or principal and a Gavilan College counselor. See Checklist in right column for details.

The campus center use fee, health fee, and student representation fee are waived for concurrently enrolled high school students.

Your Gavilan College Counseling Appointment

High school students must review their completed contract with a Gavilan College counselor. Counseling Services are available at the Gavilan main campus. See counseling hours (page 7) for dates and times.

Use the Registration Checklist to prepare for your meeting. For more information, call the Counseling secretary: 408-848-4723. A photo ID is required to obtain counseling services.

High School students may enroll in the following:

(All prerequisites apply)

- Fall and Spring Semesters: **Transfer level (courses numbered 1-99)**
- Summer Session: **All courses (transfer and non-transfer level)**

High School Students Concurrent Enrollment Registration Checklist

#1 Apply. Complete an application at least eight working days before taking the Placement/Assessment test. Go to www.gavilan.edu/admit and click on the link for Gavilan's online downloadable application.

#2 Schedule and take an assessment placement test.

Sign up online at www.gavilan.edu/admit/assess.html or call 408-846-4992.

#3 See your high school counselor.

Take your assessment test results and discuss possible courses. The course your counselor writes on the Special Student Status Contract Form is the course for which you will enroll, space permitting. Be sure the counselor signs your contract form. Directions to obtain the contract are listed in the concurrent enrollment section on this page.

#4 Get a copy of your current high school transcript

from the Registrar at your high school and attach it to your contract form. The transcript must show that you are in good standing and that you have a grade point average of at least 2.00.

#5 Ask your parent or guardian to sign the contract.

#6 Bring your transcript and signed contract to a Gavilan College counselor during the enrollment period for high school students.

#7 Register for Gavilan classes.

- Enroll for a maximum of 6 semester units of transfer level courses during the fall and spring semesters or for 5 units of pre-collegiate or transfer courses during the summer term (certain exceptions may be available for students enrolled in the TJ Owens Early College Academy)
- Pay your fees.
- Purchase a parking permit if you need one.
- Buy your books at the bookstore.

#8 Enjoy your class! You're earning college credit.

If you are enrolling in a High Step class, some steps may be facilitated by Gavilan College staff on your behalf.

Please refer to instructions for High Step students on page 18.

PLEASE NOTE:

Additional rules may apply for students enrolled in the Dr. TJ Owens Gilroy Early College Academy (GECA)

For information about

Course-to-Course Articulation Agreements

for High School Students between Gavilan College and District High Schools visit the Gavilan College website at <http://www.gavilan.edu/articulation/ArticulationAgreements.pdf>

All records of high school students attending Gavilan are protected by the Federal Educational Rights and Privacy Act (FERPA) and may not be released to anyone, including parents or guardians, without the written permission of the student.

RECOMMENDED MATH COURSE PLACEMENTS FOR AREA HIGH SCHOOL STUDENTS

Multiple measures will be considered to determine your final course placement. Consult with a counselor to select the appropriate course.

Gilroy High School

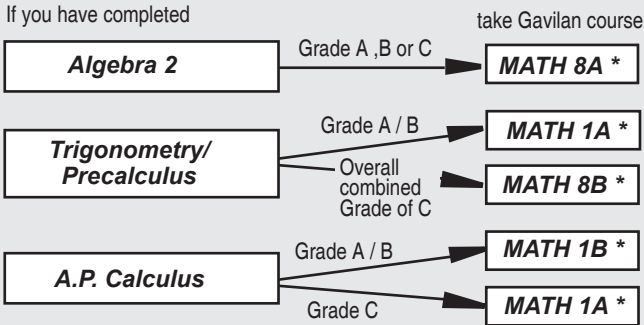

Anzar High School

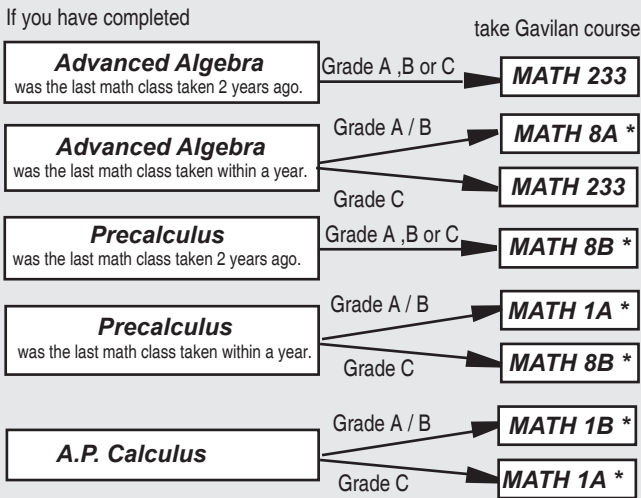

Live Oak High School

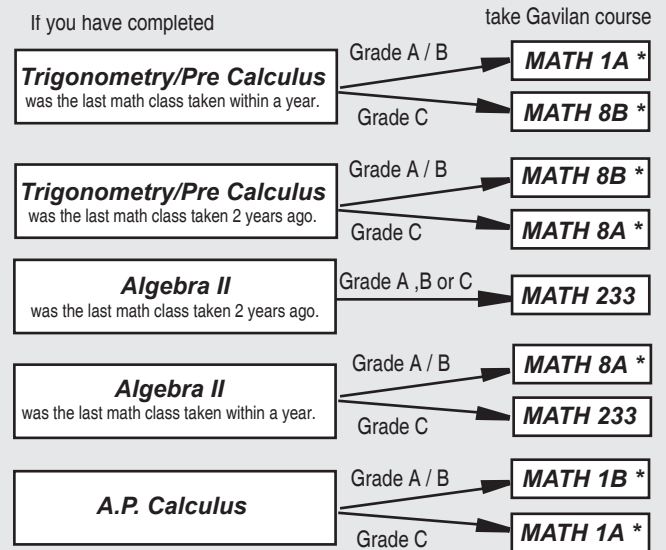

San Benito High School

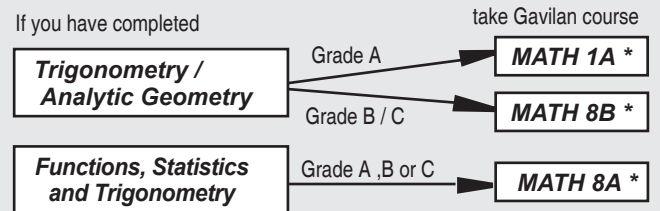

* Students eligible for these courses are also eligible for Math 5, 6, 7, 12 and 14.



Applications for the Fall 2011 Transfer Institute will be accepted beginning in May.

RAPID TRANSFER for 1st time college freshmen *Apply early!*

What is it? The Transfer Institute (TI) is a Gavilan College program to guide you through the transfer process in the most efficient and effective means possible. As a part of the Transfer Institute you will save time and money by completing your freshman and sophomore years at Gavilan. You will also meet and get to know other students who share your goals and ambition.

Who is eligible?

- Recent high school graduates who are academically prepared for college level work.
- Students with placement in college level English & Math 233.
- Students must be 1st time college freshmen.

A Transfer Institute application is downloadable online. Go to www.gavilan.edu/transfer/documents/TIApplication.pdf or visit the Counseling Department in SC113. Call 408-848-4723 for more information.



**Seniors!
Plan ahead!**

- Take the assessment and register for PUEENTE before June!
- Placed in English 250 and want to transfer? Puente may be for you.
- Learn about Mexican American/Latino Literature.
- College visits in fall/spring.
- Attend a Transfer Conference.
- Receive extra support from a community mentor.
- On-going academic, career and personal counseling until you transfer!

Meet with Puente Counselor/Coordinator Celia Marquez. Call 408-848-4723 to schedule an appointment.



HIGH STEP PROGRAM

High School Transfer Enrichment

Courses offered at high school locations are open to any college-age student.

Gavilan College, in conjunction with Gilroy and Christopher High Schools will offer transfer level courses accepted at any university each spring and fall semester at the high school campuses. All students are required to take the placement assessment prior to enrolling. All concurrent enrollment documents are required. Please contact the Gavilan Assessment Office at 408-848-4992 or your high school counselor for more information and for a schedule of the placement assessment offered at the high school campuses.

High School Juniors and Seniors!

- Start college while enrolled in High School!
- In two years earn a maximum of 12 college units.
- Courses conveniently offered at the high school.
- Meet college and university requirements while still in high school.

The Benefits:

- It's FREE! The enrollment fee, campus center use fee, health fee and student representation fee are waived for High Step students.
- Experience college level work.
- Reduce four-year university expense.
- Advance academically.
- Be competitive in the 4-year college and university admission process.

How to Register:

1. Take the Gavilan College assessment placement on your campus, at the Gavilan College Gilroy main campus or at the Morgan Hill or Hollister sites. You must complete a Gavilan application for Admission at least 8 days prior to the assessment. See your high school counselor for the application or download it from gavilan.edu/admit. Check out the assessment schedule on the web at www.gavilan.edu/admit/assess.html.
2. See your high school counselor or academic coordinator to determine eligibility (must have a cumulative 2.0 GPA, score at college level in reading, writing and math) and complete a Recommendation for Special Student Status form (High School Contract). All concurrent enrollment documents are required.
3. Ask your parent to sign the contract.
4. Turn all paperwork in to your high school counselor or academic coordinator.

Students must purchase their own textbooks. Check out the Gavilan College bookstore website at www.gavilan.bkstr.com. If you are unable to afford your textbook please see your high school principal.

High Step classes offered at Gilroy High School:

See class listings for course description.

CD 2 Early Child Development

CRN 40138 GHS-B1 D Muscari Tu 0330-0630 Dates: 2/8-5/24

PSYC 2 Early Child Development

CRN 40139 GHS-B1 D Muscari Tu 0330-0630 Dates: 2/8-5/24

High Step classes offered at Christopher High School:

See class listings for course description.

CD 3 Child Growth and Development During the School Years

CRN 40143 CHS-B101 J Weiler Th 0330-0630 Dates: 2/3-5/26

PSYC 3 Child Growth and Development During the School Years

CRN 40144 CHS-B101 J Weiler Th 0330-0630 Dates: 2/3-5/26

Room assignments subject to change. Please call 408-846-4967 or check online to confirm.

STEM stands for



Science
Technology
Engineering
Mathematics

*NOT EXACTLY THE SCIENCE
EXPERIMENT WE HAD IN MIND...
BUT WE CAN HELP WITH THAT!*

The Gavilan College STEM program is now offering support services to all students interested in the fields of Science, Technology, Engineering and Mathematics.

Students in need of academic advising, tutorial services, internship opportunities, transfer assessment and mentoring are encouraged to speak to:

Gabriel Bravo
STEM Counselor
Room LI158
408-848-4820

To schedule an appointment call 408-848-4820.

Gavilan College, in partnership with San Jose State University (SJSU), has been awarded a STEM grant of \$3,765,638. STEM grants target the areas of science, technology, engineering, and mathematics. The grant will make it possible to: improve data collection and analysis, upgrade equipment for the study of chemistry, biology and physics, augment science instruction with new software, increase math tutoring, add a portable lab with laptop computers, develop curriculum, and provide faculty training. In implementing the grant, Gavilan College will work with San Benito and Gilroy High Schools, and San Jose State University to strengthen transfer pathways.

The grant was awarded by the United States Department of Education under the College Cost Reduction Act. Its purpose is to help a greater number of Gavilan College students to major in science, technology, engineering, and mathematics and to transfer and succeed in four-year programs in science disciplines.

Instructional Support & Labs

The Gavilan **Bookstore** is located in the Student Center on the Gilroy main campus. Used books may be available at reduced cost.

Disability Resource Center's High Tech Center & Learning Skills Lab For more information, please refer to page 14.

English as a Second Language (ESL) Computer Lab

The ESL Program has its own dedicated computer lab with a variety of software programs for all levels and classes. Students, at their convenience, practice and enhance language learned in class. The ESL computer lab is located in BU119. Call 408-848-4856 for more information.

Learning Communities are two or more linked courses. You will work and study with others so you'll be more successful. You'll begin to see greater connections between the disciplines. Research shows that when you take a learning community course, you become a stronger student and do better in your other college courses.

The **Gavilan College Library** delivers an array of print and electronic resources to the college community. Augmenting the 60,000 title printed book collection are 25,000+ eBooks, and over 2,500 magazine titles, many available online in electronic databases. Recent additions include an extensive DVD, film and talking book collection. The library staff prides itself on being a leader in information literacy projects and web-based instruction and has received several state grants supporting that effort. The library faculty also teaches various courses on Internet use, and works in tandem with other faculty in planning and revising courses with an information literacy component.

The library homepage at www.gavilan.edu/library/ provides an online catalog of our book collection, links to various class websites and key online resources. The library is open from Monday-Thursday, from 8:00 am - 8:00 pm and Friday from 8:00 am - 3:00 pm. For more information call 848-4810 (Circulation) or 848-4806 (Reference.)

The **Math Lab** provides a place for students to practice math skills and receive individualized help with math problems at every level, from basic mathematics to calculus. Students work with math instructors, the math lab assistant or other students. Computers in the lab provide tutorial software as well as math software for geometry, statistics and calculus projects. The Math Lab is located in MA101. To download the daily schedule or for free math downloads, visit the website at <http://gavilan.edu/mathlab/>. For more information, call 408-848-4959.

The **MESA (Mathematics, Engineering and Science Achievement)** Undergraduate Program is a partnership between the University of California (UC) and California Community College Chancellor's Office. The program provides services to qualified students who are 1) majoring in math and science based fields (ie. Biology, Chemistry, Engineering etc.), 2) planning to transfer to 4-year universities in order to graduate with baccalaureate degrees, 3) have financial need and 4) are first generation college students. Open to all eligible students, MESA emphasizes participation by educationally underserved students. MESA provides a study center, Academic Excellence Workshops, tutoring, university trips, academic advising, transfer assistance workshops and more. For more information go to www.gavilan.edu/mesa or call 408-846-4968.

In **Service Learning** classes, students work under supervision at a partner agency in the community for 10-40 hours a semester and connect the agency experience to their classroom learning. Service learning promotes civic engagement and academic excellence, and students participating benefit themselves and the community at the same time.

You'll have positive, meaningful and real experiences in SL classes. Many students get better grades in SL classes than in non SL sections of the same classes. Some report success in investigating or discovering career options; most gain knowledge of themselves and their communities. Many practice invaluable workplace skills involving teamwork and citizenship, and report deeper learning because the results are immediate and uncontrived. Service experiences are very often personally meaningful. Many students become Lifelong Service Learners. Service Learning is common at transfer colleges, particularly the CSUs and UCs.

Transfer Institute (TI) is a selective program designed for qualified students who want to transfer to a public or private university in two years. Recent high school graduates who are academically prepared for college level work and students with placement in college level English and math 233 or higher are eligible.

The Transfer Institute will guide the student through the transfer process in the most efficient and effective means possible. As a part of the Transfer Institute students will save time and money by completing the freshman and sophomore years at Gavilan College. Students will also meet and get to know other students who share their goals and ambitions. As a Transfer Institute student you will receive a dedicated counselor to guide and monitor you through the transfer process, pre-transfer events and activities with four-year universities, access to activities designed to ensure your success at Gavilan College, assistance with the identification of and preparation for a college major and a two to three-year agreement guaranteeing transfer goals.

↳ continued

GoPrint You can now use the GoPrint system to print documents at all of Gavilan College's computer labs. No need to fumble around with coins! With your GoPrint or ASB card, you're good to go. See ad on page 3.



LIBRARY DATABASES <http://www.gavilan.edu/library>

Discover the rich resources available with your Gavilan Library card. Whether for your term-paper or your interests, current and reliable materials specifically designed for Gavilan courses are available from the library databases. About a third of all the library materials are from "proprietary" databases. That means we pay for these materials on your behalf; they are not available to the public at large. About a million online magazine and newspaper articles cover a wide range of topics, e.g.

- elections and politics
- controversial issues
- literature
- history
- health
- psychology
- sciences
- photos and images

GET YOUR LIBRARY CARD NOW!

Your library card gives you access to library resources:

- access to computers in the library
- books, eBooks, reserve materials and more
- access to all electronic databases, on campus or from home

Students can get their library cards in person or online. Library cards are available to registered Gavilan students, staff and faculty, as well as community residents with a valid photo identification. Visit <http://www.gavilan.edu/library> for more information.

A Transfer Institute application is downloadable online. Go to www.gavilan.edu/transfer/documents/TIApplication.pdf or visit the Counseling Department in SC113. Call 408-848-4723 for more information.

Tutoring Services assists students with diverse academic needs. The basic philosophy of tutoring services is to assist students in the improvement of their learning skills and understanding of course content. This is accomplished by providing students with an opportunity to discuss processes and concepts, share ideas, give examples and practice, and summarize their findings in a collaborative environment. The goal of the tutoring services is to guide students to independent learning.

Tutoring services are free to all Gavilan College students. Tutoring is offered in two locations: the Tutoring Center (LI 116) and the Computer Place (LI 168). For more information visit www.gavilan.edu/tutor or call (408) 848-4838.

The Gavilan College **Writing Center** fosters, celebrates and encourages writers. Specially trained student assistants help writers start and strengthen class assignments as well as poetry, short stories, lyrics, business letters and resumes. The center offers space for writing discussions, meeting, workshops and study groups. Special events include activities with acclaimed writers from our Visiting Writers and Scholars in Residence programs. The center collaborates with faculty to increase the likelihood of students' academic success, providing peer assist-ants for classes and labs and a variety of tools, strategies and approaches for writers.

Call (408) 848-4811 or drop by the center in LI 120 (the library building) for more information. The center is open Monday-Thursday 8 am-6 pm (closed Mondays 2:30-3:30 pm) and Friday 8 am-2 pm. From 5-6 pm on Monday-Thursday find us in the library itself.

Transfer

Students planning to transfer to a four-year institution can generally complete the first two years of their college work at Gavilan College and enter the four-year institution with junior standing. The requirements of universities vary. It is therefore advisable that students consult a counselor early in the semester for more detailed information about each university's specific requirements. *Due to recent changes in admissions policies at UCs and CSUs, working with a counselor is critical.*

The **Career/Transfer Resource Center** is located in SC101. See ad (page 23) or call 408-848-4818 for more information.

Transfer Credit Official transcripts from institutions which are fully accredited by appropriate accrediting associations will be evaluated for transferable lower division coursework. Appropriate units and subject content will be applied to major and general education requirements to meet prerequisites or graduation requirements. Courses taken at other California Community Colleges, California State Universities or any University of California will be transferred to Gavilan with the same general education designation as that of the issuing institution.

Students who wish to transfer coursework from foreign institutions must submit official transcripts to a college-approved foreign evaluation service for translation and evaluation.

Coursework from a foreign institution cannot be used for certification to a four-year institution. Students should contact the institution to which they wish to transfer to inquire about the acceptance of foreign coursework.

CLEP EXAMS: University of California does not grant credit for College Level Examination Program exams. CLEP credit CANNOT be used to certify IGETC. Some California State Universities will grant CLEP credit for certain areas and some will not grant credit at all. Transfer students are advised to contact the university they will be attending for specific information regarding CLEP credit.

Variable Topics Courses, numbered **22, 122, 23, 123, 98, 198** are also called "Independent Studies", "Special Studies", "Special Topics", "Internships", etc. Credit for variable topics courses is given only after a review of the scope and content of the course by the receiving institution. This usually occurs after transfer and may require recommendations from faculty. Check with a counselor to prevent surprises.

Transfer Services

ASSIST is an online student-transfer information system. It displays reports of how course credits earned at one California college or university can be applied when transferred to another. ASSIST provides the most accurate and up-to-date information available about student transfer in California. Visit www.assist.org.

CSU MENTOR is an online resource designed to help students and their families learn about the CSU system, select a CSU campus to attend, plan to finance higher education, and apply for admission. Personal data entered by the user is not released without the user's expressed consent and direction.

CSU Mentor is free to use. The student will only pay the application fee charged directly by the CSU campus when an application for admission is submitted. Visit the website at www.csumentor.org.

UC PATHWAYS, the University of California's online undergraduate admission information and application network.

- Information about financial aid and how to finance a UC education.
 - Answers for Transfers
 - UC campus Web sites, a list of links to the campuses for prospective students
 - Transfer/Application Center
 - Message Center - ask a question about undergraduate education or admission at UC
- Visit the website at <http://www.universityofcalifornia/admissions>

A **Transfer Admissions Agreement (TAA)** is a formal agreement between a student in attendance at Gavilan College and a receiving baccalaureate granting institution to which the student intends to transfer. The agreement guarantees admission to a transfer university a year in advance for the fall semester. Because the requirements of universities vary, it is advisable that students consult a counselor for more detailed information and to develop an educational plan. Gavilan College has Transfer Admission Agreements with several colleges and universities. Find specifics at www.gavilan.edu/counseling/TransferServices.html.

Articulation agreements are also available online at www.assist.org. For eligibility requirements visit the Counseling/Transfer Services webpage at www.gavilan.edu/counseling/TransferServices.html or call 408-848-4723 to schedule a counseling appointment.

Articulation Agreements Gavilan College has completed lower division course-to-course, major-to-major and general education agreements with most California State University (CSU), University of California (UC) and a number of private university campuses. These agreements ensure that participating universities will accept certain courses taken at Gavilan College to satisfy general education, major or elective university requirements. The articulation officer, counselors and the Career/Transfer Resource Center staff have lists of participating institutions. Articulation agreements are also available online. See information on www.assist.org and/or the Gavilan website at www.gavilan.edu/transfer.

IMPORTANT: We strongly encourage students to make a counseling appointment to prepare/develop an educational plan based on your personal, academic and career goals. Please see your counselor for additional information and to view copies of specific transfer agreements. The Counseling Office is located in SC108. For more information call 408-848-4723.

Transfer Institute Information on page 19 of this schedule.

GENERAL EDUCATION RECIPROcity AGREEMENT The Gavilan Community College District has entered into a mutual agreement with seven other Community Colleges to accept the general education of these colleges. The participating colleges are Chabot College (Hayward), De Anza College (Cupertino), Evergreen Valley College (San Jose), Foothill College (Los Altos Hills), Gavilan College (Gilroy), Las Positas (Livermore), Mission College (San Jose), Ohlone College (Fremont), San Jose City College (San Jose) and West Valley College (Saratoga).

Students who obtain a Certification of Completion of Associate Degree General Education or complete an associate degree at any of the participating colleges will have both their general education course work and graduation proficiencies accepted as completed at any one of the participating campuses.

GAVILAN COLLEGE		
ASSOCIATE'S DEGREE GENERAL EDUCATION REQUIREMENTS (2009-2010)		
<p>1. File a Petition to Graduate with the Admissions and Records Office by April 1 for Spring or Summer graduation, and by October 1 to graduate at the end of the Fall Semester. One petition must be filed for each Associate degree, Certificate of Completion or Award of Achievement the student expects to receive.</p> <p>2. Maintain a cumulative grade point average of 2.0 ("C") or higher for all work attempted and a grade of "C" or higher in each major or certificate courses.</p> <p>3. Complete a minimum of 18 units of coursework in a major. Specific major course requirements are listed in the college catalog.</p> <p>4. Complete a minimum of 60 semester units. Within the (60) unit requirement, the (9) units in Area A, and B-4 must be completed with a grade of "C" or better in each course. Complete the last 12 units, or a total of 48 units, at Gavilan College.</p> <p>NOTE: Effective fall of 2009, the new Gavilan College graduation requirements includes ENGL 1A (Area A2 of the A.A./A.S. Gavilan College General Education Pattern) and Math 233 (Area B4).</p>		
AREA A ENGLISH LANGUAGE, COMMUNICATION & CRITICAL THINKING	B - 4 MATHEMATICS	AREA E LIFELONG LEARNING AND SELF-DEVELOPMENT
<p>One course from each of these three areas: 6 Semester Units</p> <p>A - 1 ORAL COMMUNICATION CMUN 1A, 5, 8, or 10</p> <p>A - 2 WRITTEN COMMUNICATION ENGL 1A Note: Students starting fall 2009 will need to complete ENGL 1A (Composition)</p> <p>A - 3 READING ENGL 260 or SSCI 270A or SSCI 270B with a grade of "C" or better, or demonstrate reading proficiency at the college level. (Competency may be verified by an approved test.)</p>	<p>Minimum of Math 233 or equivalent. (Competency may be verified by an approved test.)</p> <p>Note: Students starting fall 2009 will need to complete MATH 233 (Intermediate Algebra)</p>	<p>3 Semester Units</p> <p>1. One unit of Physical Education activity class or Intercollegiate Sport.</p> <p>2. Minimum of two units from: AH 3, 11, 30, BIO 11; CD 2, 3; CSIS 1, 2, 6, 8, 45, 51; DM 6; GUID 1, 6, 200; HE 1, 2; LIB 6; PHIL 3B, 9; POLS 27; PSYC 2, 3, 5, 27, 41; SOC 21</p>
AREA B SCIENTIFIC INQUIRY & QUANTITATIVE REASONING	AREA C ARTS & HUMANITIES	AREA F CULTURAL DIVERSITY
<p>One course from each of these three areas: 9 Semester Units</p> <p>The Physical or Life Science course must include a laboratory (indicated in BOLD.)</p> <p>B - 1 PHYSICAL SCIENCE ASTR 1; CHEM 1A, 1B, 12A, 12B, 30A, 30B; GEOG 1; GEOL 1, 13; PHYS 1, 2A, 2B, 4A, 4B, 4C; PSCI 1, 2</p> <p>B - 2 LIFE SCIENCE ANTH 1; AH 8, 9, 15; BIO 1, 4, 5, 7, 8, 9, 10, 13, 15; ECOL 1</p> <p>B - 3 LABORATORY ACTIVITY Lab courses are bold in Areas B-1 and B-2 above.</p>	<p>One course from each of these two areas: 5 Semester Units</p> <p>C - 1 ARTS CMUN 2; HUM 10 or any Art, Journalism, Music or Theatre Arts course (other than Area C-2)</p> <p>C - 2 HUMANITIES ART 11, ENGL 1B, 1C, 2B, 2C, 2E, 2F, 2J, 4A, 4B, 5A, 5B, 9A, 9B, 9C; HIST 1, 2, 3, 4A, 4B, 5, 6, 7A, 7B, 10, 12; HUM 3, 4, 5, 10, 12; JOUR 10, PHIL 1, 2, 3A, 3B, 4, 6, 6B, SOC 10; any foreign language.</p>	<p>6 Semester Units</p> <p>NOTE: Courses in this area will "double count" to meet other GE requirements.</p> <p>2 courses from the following list; courses listed under more than one area may be used, double counted, to satisfy other general education requirements.</p> <p>AH 3, 11; ANTH 3, 5, 9, 10; ART 10A, 11; BIO 11; CD 7; CMUN 4; ENGL 2B, 2E; GEOG 2; HE 2; HIST 3, 5, 6, 10, 12; HUM 12; PHIL 6; POLS 3, 4; PSYC 7; SOC 3; SPAN 12A, 12B; THEA 1</p>
	AREA D SOCIAL SCIENCES	
	<p>One course from area one and two courses from area two: 9 Semester Units</p> <p>D - 1 U.S. HISTORY AND POLITICAL INSTITUTIONS (3 units) One course from HIST 1, 2, 5 or POLS 1</p> <p>D - 2 BEHAVIORAL, ECONOMIC and SOCIAL SCIENCE (6 units) Two courses from AJ 6, 10; ANTH 2, 3, 5, 8, 9; BUS 1; CD 2, 3, 7; CMUN 4, 6; ECON 1, 2, 10; GEOG 2; HIST 1, 2, 3, 4A, 4B, 5, 6, 10, 12; HUM 12; JOUR 10; POLS 1, 3, 4, 6; PSYC 1A, 1B, 2, 3, 6, 7; SOC 1A, 1B, 3, 4, 10; SSCI 1</p>	

AP EXAM	AA (MAJOR AND/OR GE)FOR Gavilan College	CSU GE	CSU - UNITS EARNED TOWARD TRANSFER	IGETC
Art History	ART 1A	Area C1 or C2 3 semester units	6 semester units	Area 3A or 3B*** 3 semester units
Art (Studio)	No course equiv. - 3 units elective	N/A	3 semester units	N/A
Biology	BIO 10	Area B2 and B3 4 semester units	6 semester units	Area 5B (with lab) 4 semester units
Calculus AB	Score of 3 – MATH 8B Score of 4 or 5 – MATH 1A 4 Semester units	Area B4 3 semester units	3 semester units*	Area 2A 3 semester units
Calculus BC	Score of 3 – MATH 1A Score of 4 or 5 – MATH 1B 4 Semester units	Area B4 3 semester units	6 semester units*	Area 2A 3 semester units
AP CALCULUS EXAM LIMITATIONS:			*Only one exam may be used toward transfer	
Chemistry	CHEM 30A 4 semester units	Areas B1 and B3 4 semester units	6 semester units	Area 5A (with lab) 4 semester units
Chinese Language & Culture	No course equivalency GE Humanities 3 semester units	Area C2 3 semester units	6 semester units	Area 3B and 6A 3 semester units
Computer Science A	CSIS 45 3 Semester units	N/A	3 semester units**	N/A
Computer Science AB	CSIS 45 & 46 6 semester units	N/A	6 semester units**	N/A
AP CS EXAM LIMITATIONS:			**Maximum one exam toward transfer	
Economics - Macroeconomics	ECON 1 3 semester units	Area D2 3 semester units	3 semester units	Area 4B 3 semester units
Economics - Microeconomics	ECON 2 3 semester units	Area D2 3 semester units	3 semester units	Area 4B 3 semester units
English - Language & Composition	ENGL 1A 3 semester units	Area A2 3 semester units	6 semester units	Area 1A 3 semester units
English - Literature & Composition	ENGL 1A & ENGL 1B 6 semester units	Area A2 and C2 6 semester units	6 semester units	Area 1A or 3B*** 3 semester units
AP ENGLISH EXAM LIMITATIONS:				
Environmental Science	ECOL 1 4 semester units	Area B2 and B3 (if taken prior to Fall 2009) Or Area B1 and B3 (regardless of when taken). 4 semester units	4 semester units	Area 5A (with lab) 3 semester units
French Language	FRNH 2A 5 semester units	Area C2 3 semester units	6 semester units	Area 3B and 6A 3 semester units
French Literature	No course equivalency GE Humanities 3 semester units	Area C2 3 semester units	6 semester units	Area 3B and 6A 3 semester units
German Language	No course equivalency GE Humanities 3 semester units	Area C2 3 semester units	6 semester units	Area 3B and 6A 3 semester units
Government & Politics - Comparative	POLS 3 3 semester units	Area D8 3 semester units	3 semester units	Area 4H 3 semester units
Government and Politics - U.S.	POLS 1 3 semester units	Area D8 and US 2* 3 semester units	3 semester units	Area 4H 3 semester units
History - European	HIST 7A 3 semester units	Area C2 or D6 3 semester units	6 semester units	Area 3B or 4F*** 3 semester units
History - U.S.	HIST 1 3 semester units	Area C2 or D6 3 semester units	6 semester units	Area 3B or 4F*** 3 semester units
History - World	HIST 4A 3 semester units	Area C2 or D6 3 semester units	6 semester units	Area 3B or 4F*** 3 semester units
Human Geography	GEOG 2 3 semester units	Area D5 3 semester units	3 semester units	Area 4E 3 semester units
Italian Language & Culture	No course equivalency GE Humanities 3 semester units	Area C2 3 semester units	6 semester units	Area 3B and 6A 3 semester units
Japanese Language & Culture	No course equivalency GE Humanities 3 semester units	Area C2 3 semester units	6 semester units	Area 3B and 6A 3 semester units
Latin - Vergil	No course equivalency GE Humanities 3 semester units	Area C2 3 semester units	3 semester units	Area 3B and 6A 3 semester units
Latin - Literature	No course equivalency GE Humanities 3 semester units	Area C2 3 semester units	6 semester units	Area 3B and 6A 3 semester units
Music Theory	MUS 3A 3 semester units	Area C1 (if taken prior to Fall 2009) 3 semester units	6 semester units	N/A
Physics B	PHYS 2A 4 semester units	B1 and B3 4 semester units*	6 semester units*	Area 5A (with lab) 4 semester units
Physics C - Mechanics	PHYS 4A 4 semester units	Area B1 and B3 4 semester units*	4 semester units*	Area 5A (with lab) 3 semester units
Physics C - Magnetism	PHYS 4B 4 semester units	Area B1 and B3 4 semester units*	4 semester units*	Area 5A (with lab) 3 semester units
AP PHYSICS EXAM LIMITATIONS:			*Maximum 4 semester units toward GE and 6 semester units toward transfer	
Psychology	PSYC 1A 3 semester units	Area D9 3 semester units	3 semester units	Area 4I 3 semester units
Spanish Language	SPAN 2A 5 semester units	Area C2 3 semester units	6 semester units	Area 3B and 6A 3 semester units
Spanish Literature	No course equivalent GE Humanities 3 semester units	Area C2 3 semester units	6 semester units	Area 3B and 6A 3 semester units
Statistics	MATH 5	Area B4	3 semester units	Area 2

Advanced Placement (AP)

Students may earn credit for College Entrance Examination Board (CEEB) Advanced Placement (AP) Tests with scores of

3, 4, or 5. AP credit can be used to meet IGETC, CSU GE and A.A. general education (GE) and/or major requirements.

Students receiving a score of 3, 4 or 5 on the Math and English AP exams will be exempted from the placement assessment test. AP units will not apply toward financial aid, nor can they be used to satisfy the residency unit requirement.

AA: Students should be aware that AP test credit is evaluated by corresponding it to an equivalent Gavilan College course, e.g. History 1. A student who receives AP credit and then takes the equivalent Gavilan College course will have the unit credit for such duplication deducted prior to being awarded the A.A. degree. Credit by Advanced Placement exam is noted and listed first on a student's transcript, with units assigned and no grade.

CSU GE: The Advanced Placement examinations may be incorporated into the certification of CSU General Education-Breath requirements by any certifying institution. All CSU campuses will accept the minimum units shown and apply them toward fulfillment of the designated General Education-Breath area if the examination is included as part of a full or subject-area certification. Please note that individual CSU campuses may choose to grant more units than those specified toward completion of General Education-Breath requirements.

IGETC: AP exams must be used in area indicated regardless of where the certifying CCC's discipline is located.

***AP exams may be used in either area regardless of where the certifying CCC's discipline is located. Example: US History at a CCC is approved for Area 3B. The US History AP may be used in either Area 3B or 4F.

Scores of "3" may not be accepted for all courses by some 4 year colleges and universities.

California Articulation Number System

CAN

The California Articulation Number (CAN) System provides a cross reference number for courses which have been evaluated by faculty and determined to be acceptable "in lieu of" each other. Only lower division, transferable, major preparation courses commonly taught on two- and four-year college and university campuses are included in the System.

The criteria for a campus to qualify to use a CAN Number includes written, faculty-approved articulation agreements on each course with a minimum of four public four-year California colleges and universities.

The CAN Number System is not a common numbering system. Each campus retains its own course numbers, prefixes and titles. The CAN (e.g., CAN ENGL 2) is listed parenthetically in catalog descriptions, class schedules and other publications as appropriate.

The CAN designation is assurance that the course or sequence of courses will be accepted in lieu of an identically designated CAN course or sequence at all participating campuses in California.

(CAN ENGL1A = CAN ENGL 1A at another college.)

Intersegmental General Education Transfer Curriculum (IGETC)

The IGETC can be used by community college transfer students to fulfill lower division general education requirements for either the CSU or UC system without the need, after transfer, to take additional lower division general education courses, as long as your IGETC completion is certified at the community college. Obtain the Certification form from Admissions and Records.

Students are strongly encouraged to complete all IGETC requirements prior to transfer.

PARTIAL IGETC - If you are approaching readiness for transfer and are unable to complete one or two IGETC courses, you may be eligible to complete IGETC after transferring.

Warning: Students need Area 1 and 2 completed to meet minimum transfer admission requirements. Therefore, partial certification that acknowledges a deficiency in Area 1 and/or 2 may also indicate a student does not meet minimum transfer requirements.

If your petition for partial certification of IGETC is approved, you may be able to complete IGETC in one of the following ways:

- 1) Take an approved IGETC course, in the area(s) to be completed, at any California Community College, at a time that does not require concurrent enrollment, such as during the summer.
- 2) Take a course approved by the UC or CSU campus of attendance in the area(s) to be completed at a U.S. regionally accredited institution at a time that does not require concurrent enrollment, such as during summer school.
- 3) Take an approved IGETC course, in the area(s) to be completed, at any California Community College while concurrently enrolled at a UC or CSU campus. The student will be subject to the UC or CSU campus rules regarding concurrent enrollment, so this option may not be available.
- 4) Take a course approved by the UC or CSU campus of attendance at a United States regionally accredited institution in the area(s) to be completed while concurrently enrolled at a UC or CSU campus. The student will be subject to the UC or CSU campus rules regarding concurrent enrollment, so this option may not be available.
- 5) Take a comparable course at a UC or CSU campus in the area(s) to be completed. This option is at the discretion of each UC or CSU campus, so it may not be a choice available to the student.

You will be expected to complete IGETC before the beginning of the second full year of enrollment at your UC or CSU campus. Check with your campus advisor after you transfer for more information, including which options are available and which UC or CSU courses may be comparable to the IGETC courses remaining to be completed.

All UC and CSU campuses will accept IGETC with the exception of Fifth and Revelle Colleges at UC, San

Visit the

Career/Transfer Resource Center

Services are designed to assist you throughout your time at Gavilan College.

- ◆ Information on career outlook, training and educational opportunities
- ◆ Career Assessment using EUREKA
- ◆ College Fair and Career Fair
- ◆ Transfer information
- ◆ Career and Transfer Workshops
- ◆ Articulation agreements using ASSIST
- ◆ College and university catalogs
- ◆ Assistance with admission procedures and referral to academic counseling
- ◆ Library of career reference materials
- ◆ Online Job Search/Research Portal

Located in SC101 on the main campus.
For more information call 408-848-4818
or visit the website at
www.gavilan.edu/transferctr

Diego. Since all majors are available at each of the five colleges at UC, San Diego, students will not be restricted in their choice of major if they use the IGETC.

A course cannot be used to satisfy more than one subject area of the IGETC (general education). However, major prerequisite courses can be used (double counted) to satisfy IGETC requirements.

CSU campuses' limitations on double counting of general education courses toward major preparations are not changed by IGETC.

Students who wish to be certified for both CSU and UC systems should take CMUN 1A, 5, 8 or 10 in Area 1 for CSU and meet the foreign language requirement for UC. Completing both provides flexibility and choices.

The courses for all IGETC areas must be completed with a grade of "C" or better before IGETC can be certified. A grade of "C-" is not acceptable.

UC/CSU Intersegmental General Education Transfer Curriculum IGETC - 2009-2010

Completion of all the requirements in the IGETC will permit a student to transfer from a community college to the California State University or the University of California without the need, after transfer, to take additional lower-division general education courses to satisfy campus general education requirements. All areas must be satisfied, and all courses must be completed with a grade of "C" or better before the IGETC can be certified. See requirements for partial IGETC certification in catalog. A student is strongly advised to complete a total of 60 transferable units before transferring. These will include the IGETC requirements, "major" prerequisites, and elective courses if needed.

(Students should request an IGETC certification from the Office of Admissions and Records before transferring.)

AREA 1 ENGLISH COMMUNICATION	AREA 3 ARTS AND HUMANITIES	
<p>CSU - 3 courses required, one each from Group A, B, and C</p> <p>UC - 2 courses required, one each from Group A and B</p> <p>1-A English Composition</p> <p>ENGL 1A Composition (3)</p> <p>1-B Critical Thinking / English Composition</p> <p>ENGL1C Critical Reasoning and Writing (3)</p> <p>PHIL 4 Critical Thinking and Writing (3)</p> <p>1-C Oral Communication (CSU requirement only)</p> <p>CMUN1A Introduction to Public Speaking (3)</p> <p>CMUN 5 Fund of Com Studies (3)</p> <p>CMUN 8 Interpersonal Communication (3)</p> <p>CMUN 10 Small Group Communication (3)</p>	<p>At least 3 courses, with at least one course from the Arts and one course from the Humanities.</p> <p>3-A Arts</p> <p>ART 1A Art History (3)</p> <p>ART 1B Art History (3)</p> <p>ART 6 Art Appreciation (3)</p> <p>HUM 6 Foreign Cinema (3)</p> <p>MUS 1A Music History and Literature (3)</p> <p>MUS 1B Music History and Literature (3)</p> <p>MUS 2** History of Jazz and Rock Music (3)</p> <p>MUS 6 Intro to World Music (3)</p> <p>THEA 1 Theater History (3)</p> <p>THEA 3 El Teatro Campesino (3)</p> <p>THEA 7 Theater Appreciation</p> <p>3-B Humanities</p> <p>ENGL 1B Composition and Literature (3)</p> <p>ENGL 2B Intro to Multi-Cultural Literature (3)</p> <p>ENGL 2C Introduction to Film and Fiction (3)</p> <p>ENGL 2E Introduction to Women Writers (3)</p> <p>ENGL 2F Childrens's Literature ** (3)</p> <p>ENGL 2J Mythology (3)</p> <p>ENGL 4A British Literature - 449 through 1798 (3)</p> <p>ENGL 4B British Literature - 1798 to present (3)</p> <p>ENGL 5A Survey of American Literature - 1620 - 1865 (3)</p> <p>ENGL 5B Survey of American Literature - 1865 to present (3)</p> <p>* FRNH 2A Intermediate French** (5)</p> <p>* HIST 1 U.S. Hist through Reconstruction (3)</p> <p>* HIST 2 U.S. Hist Reconstrucion to Present (3)</p> <p>* HIST 3 History of California (3)</p> <p>* HIST 4A Hist of World Societies Before 1500 (3)</p> <p>* HIST 4B History of World Societies - 1500 to Present (3)</p> <p>* HIST 5 Women's Lives in Early U.S. Hist (3)</p> <p>* HIST 6 Women's Lives in Recent U.S. Hist (3)</p> <p>HIST 7A History of Western Civilization (3)</p> <p>HIST 7B History of Western Civilization (3)</p> <p>* HIST 10 African American History (3)</p> <p>* HIST 12 Mexican American Cultural History (3)</p>	<p>HUM 3 Introduction to the Cinema (3)</p> <p>HUM 4 Intro to the American Cinema (3)</p> <p>HUM 5 Humanities Through the Arts (3)</p> <p>HUM 10 Approaches to Contemporary Film (3)</p> <p>* HUM 12 Mexican American Cultural History (3)</p> <p>PHIL 1 Introduction to Philosophy (3)</p> <p>PHIL 3A Ethics (3)</p> <p>PHIL 3B Contemporary Moral Issues (3)</p> <p>PHIL 6 Comparative Religions (3)</p> <p>PHIL 9 Philosophy of Religion (3)</p> <p>* SPAN 2A Intermediate Spanish (5)</p> <p>* SPAN 2B Intermediate Spanish (5)</p>
AREA 2 MATHEMATICAL CONCEPTS AND QUANTITATIVE REASONING		AREA 4 SOCIAL AND BEHAVIORAL SCIENCES
<p>1 course, 3 semester, 4-5 quarter units</p> <p>2-A Math</p> <p>CSIS 26 Discrete Mathematics (4)</p> <p>+ BUS 11 Statistics for Business & Economics (4)</p> <p>+ ECON 11 Statistics for Business & Economics (4)</p> <p>+ MATH 1A Single Variable Calculus & Analytic Geometry (4)</p> <p>MATH 1B Single Variable Calculus & Analytic Geometry (4)</p> <p>MATH 1C Multivariable Calculus (4)</p> <p>MATH 2 Linear Algebra (3)</p> <p>MATH 2C Differential Equations (3)</p> <p>MATH 5 Introductions to Statistics (3)</p> <p>+ MATH 6 Calc for Bus / Social Sci (3)</p> <p>MATH 7 Finite Mathematics (3)</p> <p>+ MATH 8A First Half of Precalculus (4)</p> <p>+ MATH 8B Second Half of Precalculus (4)</p> <p>MATH 14 Math for the Liberal Arts (3)</p>		<p>Three courses from at least two disciplines or an interdisciplinary sequence. 9 semester, 12-15 quarter units.</p> <p>4-A Anthropology and Archeology</p> <p>ANTH 2 Introduction to Archeology (3)</p> <p>ANTH 3 Intro to Cultural Anthropology (3)</p> <p>ANTH 5 Magic, Witchcraft and Religion (3)</p> <p>ANTH 8 Intro to New World Archeology (3)</p> <p>4-B Economics</p> <p>+ ECON 1 Principles of Macroeconomics (3)</p> <p>+ ECON 2 Principles of Microeconomics (3)</p> <p>+ ECON 10 Fundamentals of Economics (3)</p> <p>4-E Geography</p> <p>GEOG 2 Cultural Geography (3)</p> <p>4-F History</p> <p>* HIST 1 U.S.Hist through Reconstruction (3)</p> <p>* HIST 2 United States History: Reconstruction to the Present (3)</p> <p>* HIST 3 History of California (3)</p> <p>* HIST 4A History of World Societies Before 1500 (3)</p>

<p>4-F History - Cont.</p> <p>* HIST 4B History of World Societies 1500 to Present (3)</p> <p>* HIST 5 Women's Lives in Early U.S. Hist. (3)</p> <p>* HIST 6 Women's Lives in Recent U.S. History (3)</p> <p>* HIST 10 African American History (3)</p> <p>* HIST 12 Mexican American Cultural History (3)</p> <p>* HUM 12 Mexican American Cultural History (3)</p> <p>4-G Interdisciplinary, Social & Behavioral Science</p> <p>CMUN 4 Intercultural Communication (3)</p> <p>SSCI 1 Introduction to Social Sciences (3)</p> <p>4-H Political Science, Government & Legal Institutions</p> <p>POLS 1 Intro to American Government (3)</p> <p>POLS 3 Intro to Comparative Politics (3)</p> <p>POLS 4 Intro to International Relations (3)</p> <p>4-I Psychology</p> <p>CD 2 Early Childhood Development (3)</p> <p>CD 3 Child Growth and Development During the School Years (3)</p> <p>PSYC 1A Introduction to Psychology (3)</p> <p>PSYC 1B Introduction to Psychology (3)</p> <p>PSYC 2 Early Childhood Development (3)</p> <p>PSYC 3 Child Growth and Development During the School Years (3)</p> <p>4-J Sociology & Criminology</p> <p>JOUR 10 Mass Media and Society (3)</p> <p>SOC 1A Introduction to Sociology (3)</p> <p>SOC 1B Intro to Sociology: Social Problems (3)</p> <p>SOC 3 Sociology of Race, Ethnicity and Cultural Identity (3)</p> <p>SOC 4 Sociology of Women and Men (3)</p> <p>SOC 10 Mass Media and Society (3)</p>	<p>+ CHEM 30A Elementary Chemistry (4)</p> <p>CHEM 30B Elementary Organic Biochemistry(4)</p> <p>GEOG 1 Physical Geography (3)</p> <p>GEOL 1 Introduction to Geology (4)</p> <p>GEOL 13 Environmental Geology (3)</p> <p>+ PHYS 1 Introduction to Physics (4)</p> <p>+ PHYS 2A General Physics (4)</p> <p>+ PHYS 2B General Physics (4)</p> <p>+ PHYS 4A Physics for Scientists and Engineers (Mechanics/Fluids/Waves) (4)</p> <p>+ PHYS 4B Physics for Scientists and Engineers (Electromagnetism) (4)</p> <p>+ PHYS 4C Physics for Scientists and Engineers(Thermodynamic/Optics/Moderns Physics) (4)</p> <p>+ PSCI 1 Principles of Physical Science (3)</p> <p>PSCI 2 Introduction to Meteorology (3)</p> <p>5B Biological Science</p> <p>AH 8 General Microbiology (5)</p> <p>+ AH 9 Human Physiology (5)</p> <p>+ AH 15 Survey of Human Anatomy and Physiology (5)</p> <p>ANTH 1 Intro to Physical Anthropology (3)</p> <p>BIO 1 General Biology (4)</p> <p>BIO 4 General Zoology (4)</p> <p>BIO 5 General Botany (4)</p> <p>+ BIO 7 Human Anatomy (4)</p> <p>BIO 8 General Microbiology (5)</p> <p>+ BIO 9 Human Physiology (5)</p> <p>+ BIO 10 Principles of Biology (4)</p> <p>BIO 13 Marine Biology (4)</p> <p>+ BIO 15 Survey of Human Anatomy and Physiology (5)</p> <p>ECOL 1 Conservation of Nat Resources (4)</p> <p>+ Transfer credit may be limited by either UC or CSU or both. Please consult with a counselor.</p>	<p>CSU Graduation Requirement in U.S. History, Constitution and American Ideals.</p> <p>Not Part of IGETC (May be completed prior to transfer.)</p> <p>For the baccalaureate degree, CSU requires one of the following combinations:</p> <p>HIST 1 & 2 or</p> <p>POLS 1 with either HIST 1 or 2</p> <p>CSU campuses have the discretion whether to allow courses used to satisfy the CSU US History, Constitution and American Ideals (AI) graduation requirement to count in both Area 3B or 4F and to meet the graduation requirement.</p>
<p>AREA 5 PHYSICAL AND BIOLOGICAL SCIENCES</p>	<p>AREA 6 LANGUAGE OTHER THAN ENGLISH (UC REQUIREMENT ONLY)</p>	<p>SUPPLEMENTARY NOTES</p> <ol style="list-style-type: none"> 1. A single course, even though listed in more than one place, can only be used to satisfy one subject area of the IGETC. 2. IGETC is not advisable for high-unit majors, e.g. sciences, engineering. 3. Eleanor Roosevelt and Revelle Colleges at UC San Diego do not accept the IGETC. 4. IGETC may not be appropriate for students who have completed courses at a CSU or UC campus. 5. "Double counting" of courses toward the major is not limited by the IGETC, but may be limited by other directives. The UC will also allow IGETC courses to count toward major requirements. CSU campus limitations on double counting of general education courses toward major preparation are not changed by the IGETC.
<p>At least 2 courses, one Physical Science course and one Biological Science course; At least one must include a laboratory.</p> <p>Courses in BOLD include a laboratory component.</p> <p>7-9 semester, 9-12 quarter units</p> <p>5-A Physical Science</p> <p>ASTR 1 Intro to General Astronomy (3)</p> <p>CHEM 1A General Chemistry (5)</p> <p>CHEM 1B General Chemistry (5)</p> <p>CHEM 12A Organic Chemistry (5)</p> <p>CHEM 12B Organic Chemistry (5)</p>	<p>Proficiency equivalent to two years of high school study in the same language.</p> <p>6-A Language Other Than English</p> <p>CHN 1B Elementary Mandarin** (5)</p> <p>FRNH 1B Elementary French (5)</p> <p>* FRNH 2A Intermediate French** (5)</p> <p>JPN 1B Elementary Japanese (5)</p> <p>SPAN 1B Elementary Spanish (5)</p> <p>* SPAN 2A Intermediate Spanish (5)</p> <p>* SPAN 2B Intermediate Spanish (5)</p> <p>* SPAN 12A Spanish for Spanish Speakers (5)</p> <p>* SPAN 12B Spanish for Spanish Speakers - Intermediate / Advanced (5)</p>	<p>+ Transfer credit may be limited by either UC or CSU or both. Please consult with a counselor.</p> <p>* Courses listed in multiple areas shall not be certified in more than one area except for courses in Languages Other Than English, which can be certified in both areas 3B and 6A.</p> <p>** Approved for fall 2010.</p>

DISCRIMINATION / HARASSMENT COMPLAINTS

Call Equal Opportunity Officer at 408-848-4731.

CSU General Education (Breadth) Requirements 2009-2010

certified by Gavilan College

Students transferring to the California State University system will qualify for admission as upper division transfers if they have completed (60) transferable units with a GPA of 2.0 ("C") or better (non-residents 2.4 or better). Within the (60) unit requirement, the (9) units in Area A, Area B-4 (Mathematics), and (18) additional semester units of general education coursework must be completed with a grade of 2.0 or better in each course. Students who complete the following pattern will have satisfied the lower division General Education requirements for the California State University BA / BS degree. A minimum of (9) semester units of General Ed coursework must be completed at the upper division level after transfer; some CSU campuses require more than (9) units. (See a counselor for further information.) (Students should request a general education certification from the office of Admissions and Records before transferring.)

AREA A		B - 2 LIFE SCIENCE		ART 6 Art Appreciation (3)	
ENGLISH LANGUAGE, COMMUNICATION AND CRITICAL THINKING Select one course from each category. All courses must be completed with a grade of "C" or better. 9 semester units or 12-15 quarter units		AH8 General Microbiology (5) AH9 Human Physiology (5) AH15 Survey of Human Anatomy and Physiology (5) ANTH 1 Intro to Physical Anthropology (3) ECOL 1 Conservation of Natural Resources(4) BIO 1 General Biology (4) BIO 4 General Zoology (4) BIO 5 General Botany (4) BIO 7 Human Anatomy (4) BIO 8 General Microbiology (5) BIO 9 Human Physiology (5) BIO 10 Principles of Biology (4) BIO 13 Marine Biology (4) BIO 15 Survey of Human Anatomy and Physiology (5)		ART 8A Beginning Photography From Analog to Digital (3) ART 10A Cultural History of Ceramics (3) ART 13 Three Dimensional Design (3) ART 14 Beginning Mural Painting (3) ART 25A Art Methods (3) CD 25A Art Methods (3) CMUN 2 Oral Reading (3) HUM 6 Foreign Cinema (3) HUM 10 Approaches to Contemporary Film (3) MUS 1A Music, History, and Literature (3) MUS 1B Music, History, and Literature (3) MUS 2* History of Jazz and Rock Music (3) MUS 3A Harmony-Theory-Musicianship (4) MUS 4A Beginning Piano (3) MUS 6 Intro to World Music (3) THEA 1 Theater History (3) THEA 3 El Teatro Campesino (3) THEA 4 Oral Reading (3) THEA 7 Theater Appreciation (3) THEA 12A Acting: History and Practice (3) THEA 20 Introduction to Script Writing (3)	
A - 1 ORAL COMMUNICATION CMUN 1A Introduction to Public Speaking (3) CMUN 5 Fundamentals of Comm Studies (3) CMUN 8 Interpersonal Communication (3) CMUN 10 Small Group Communication (3)		B - 3 LABORATORY ACTIVITY See Areas B - 1 & B - 2 above		C - 2 Humanities (Literature, Philosophy, Foreign Language) ART 11 Creativity, Imagination, & Innovation(3) CHN 1A* Elementary Mandarin (5) CHN 1B* Elementary Mandarin (5) ENGL 2B Intro to Multi-Cultural Literature (3) ENGL 2C Intro to Film and Fiction (3) ENGL 2E Introduction to Women Writers (3) ENGL 2F Children's Literature* (3) ENGL 2J Mythology (3) ENGL 4A British Literature - 449 through 1798(3) ENGL 4B British Literature - 1798 to present (3) ENGL 5A Survey of American Literature - 1620 - 1865 (3) ENGL 5B Survey of American Literature - 1865 to present (3) ENGL 9A Introduction to Creative Writing (3) ENGL 9B Advanced Creative Writing (3) ENGL 9C Poetry Writing (3) FRNH 1A Elementary French (5) FRNH 1B Elementary French (5) FRNH 2A* Intermediate French (5)	
A - 2 WRITTEN COMMUNICATION ENGL 1A Composition (3)		B - 4 Mathematics/Quantitative Reasoning Grade "C" or better is required BUS 11 Statistics for Bus and Econ (4) CSIS 26 Discrete Mathematics (4) ECON 11 Statistics for Bus and Econ (4) MATH 1A Single-Variable Calculus and Analytic Geometry (4) MATH 1B Single-Variable Calculus and Analytic Geometry (4) MATH 1C Multivariable Calculus (4) MATH 2 Linear Algebra (3) MATH 2C Differential Equations (3) MATH 5 Introductions to Statistics (3) MATH 6 Calculus for Bus / Social Science (3) MATH 7 Finite Mathematics (3) MATH 8A First Half of Precalculus (4) MATH 8B Second Half of Precalculus (4) MATH 12 Math for Elementary Teachers (3) MATH 14 Math for the Liberal Arts (3)			
A - 3 CRITICAL THINKING ENGL 1C Critical Reasoning and Writing (3) PHIL 2 Logic (3) PHIL 4 Critical Thinking and Writing (3)		AREA C ARTS AND HUMANITIES Required: English 1B, one course from C-1 and one course from C-2 9 semester units or 12-15 quarter units			
AREA B SCIENTIFIC INQUIRY AND QUANTITATIVE REASONING One course from each category. The Physical or Life Science course must include a laboratory (indicated in BOLD). 9 semester units or 12-15 quarter units		B - 1 PHYSICAL SCIENCE ASTR 1 Intro to General Astronomy (3) CHEM 1A General Chemistry (5) CHEM 1B General Chemistry (5) CHEM 12A Organic Chemistry (5) CHEM 12B Organic Chemistry (5) CHEM 30A Elementary Chemistry (4) CHEM 30B Elementary Organic Biochemistry (4) GEOG 1 Physical Geography (3) GEOL 1 Introduction to Geology (4) GEOL 13 Environmental Geology (3) PHYS 1 Introduction to Physics (4) PHYS 2A General Physics (4) PHYS 2B General Physics) (4) PHYS 4A Physics for Scientists & Engineers (Mechanics / Fluids / Waves) (4) PHYS 4B Physics for Scientists and Engineers (Electromagnetism) (4) PHYS 4C Physics for Scientists & Engineers (Thermodynamic / Optics Moderns Physics) (4) PSCI 1 Principles of Physical Science (3) PSCI 2 Introduction to Meteorology (3)		C - 1 Arts (Art, Dance Music, Theater) Minimum of 2 units from one of these courses. ART 1A Art History (3) ART 1B Art History (3) ART 2A Two Dimensional Design (3) ART 3A Drawing and Composition (3)	

<p>C - 2 Humanities (continued)</p> <p>HIST 1 U.S. Hist through Reconstruction (3) HIST 2 United States History - Reconstruction to the Present (3) HIST 3 History of California (3) HIST 4A History of World Societies Before 1500 (3) HIST 4B History of World Societies Before 1500 (3) HIST 5 Women's Lives in Early U.S. History (3) HIST 6 Women's Lives in Recent U.S. History (3) HIST 7A, History of Western Civilization (3) HIST 7B History of Western Civilization (3) HIST 10 African American History (3) HIST 12 Mexican American Cultural History (3) HUM 3 Introduction to the Cinema (3) HUM 4 Intro to the American Cinema (3) HUM 5 Humanities Through the Arts (3) HUM 10 Approaches to Contemporary Film (3) HUM 12 Mexican American Cultural History (3) JPN 1A ± Elementary Japanese (5) JPN 1B ± Elementary Japanese (5) JOUR 10 Mass Media and Society (3) PHIL 1 Introduction to Philosophy (3) PHIL 3A Ethics (3) PHIL 3B Contemporary Moral Issues (3) PHIL 6 Comparative Religions (3) PHIL 9 Philosophy of Religion (3) SOC 10 Mass Media and Society (3) SPAN 1A, Elementary Spanish) (5) SPAN 1B Elementary Spanish) (5) SPAN 2A Intermediate Spanish (5) SPAN 2B Intermediate Spanish) (5) SPAN 12A Spanish for Spanish Speakers (5) SPAN 12B Spanish for Spanish Speakers Intermediate/Advanced (5)</p>	<p>NOTE: For the baccalaureate degree, one of the following combinations will satisfy the CSU graduation requirement in US History, Constitution and American Ideals:</p> <p>HIST 1 & 2, POLS 1 with either HIST 1 or 2.</p> <p>Requirement 2:</p> <p>D - 1 Anthropology and Archeology</p> <p>ANTH 2 Introduction to Archeology (3) ANTH 3 Intro to Cultural Anthropology (3) ANTH 5 Magic, Witchcraft and Religion (3) ANTH 8 Intro to New World Archeology (3)</p> <p>D - 2 Economics</p> <p>ECON 1 Principles of Macroeconomics (3) ECON 2 Principles of Microeconomics (3) ECON 10 Fundamentals of Economics (3)</p> <p>D - 3 Ethnic Studies</p> <p>CMUN 4 Intercultural Communication (3) HIST 10 African American History (3) HIST 12 Mexican American Cultural History (3) HUM 12 Mexican American Cultural History (3) SOC 3 Sociology of Race, Ethnicity & Cultural Identity (3)</p> <p>D - 4 Gender Studies</p> <p>HIST 5 Women's Lives in Early U.S. Hist. (3) HIST 6 Women's Lives in Recent U.S. Hist. (3) SOC 4 Sociology of Women and Men (3)</p> <p>D - 5 Geography</p> <p>GEOG 2 Cultural Geography (3)</p> <p>D - 6 History</p> <p>HIST 1 U.S. Hist through Reconstruction (3) HIST 2 United States History - Reconstruction to the Present (3) HIST 3 History of California (3) HIST 4A History of World Societies Before 1500 (3) HIST 4B History of World Societies Before 1500 to Present (3) HIST 5 Women's Lives in Early U.S. Hist. (3) HIST 6 Women's Lives in Recent U.S. Hist. (3) HIST 10 African American History (3) HIST 12 Mexican American Cultural History (3) HUM 12 Mexican American Cultural History (3)</p> <p>D - 7 Interdisciplinary Social & Behavioral Sci.</p> <p>AJ 6 Intro to Conflict Resolution (3) ANTH 9 Cultural Context of Childhood (3) CD 7 Cultural Context of Childhood (3) CMUN 4 Intercultural Communication (3) CMUN 6 Intro to Conflict Resolution (3)</p>	<p>POLS 6 Conflict Resolution (3) PSYC 6 Intro to Conflict Resolution (3) PSYC 7 Cultural Context of Childhood (3) SSCI 1 Introduction to Social Sciences (3)</p> <p>D - 8 Political Science, Government and Legal Institutions</p> <p>POLS 1 Intro to American Government (3) POLS 3 Intro to Comparative Politics (3) POLS 4 Intro to International Relations (3)</p> <p>D - 9 Psychology</p> <p>CD 2 Early Childhood Development (3) CD 3 Child Growth and Development During the School Years (3) PSYC 1A, B Intro to Psychology (3) (3) PSYC 2 Early Childhood Development (3) PSYC 3 Child Growth and Development During the School Years (3)</p> <p>D - 0 Sociology and Criminology</p> <p>JOUR 10 Mass Media and Society (3) SOC 1A Introduction to Sociology (3) SOC 1B Introduction to Sociology: Social Problems (3) SOC 3 Sociology of Race, Ethnicity and Cultural Identity (3) SOC 4 Sociology of Women and Men (3) SOC 10 Mass Media and Society (3)</p>
<p>AREA D SOCIAL SCIENCES</p>	<p>Courses listed under more than one discipline or area may be used only once to satisfy an area.</p> <p>* = Approved for Fall 2010 ± = Approved retroactively for Fall 2005.</p> <p>NOTE: "±" or "»" . PSYC 2 + 3 acceptable for AREA E only if taken as combination.</p> <p>NOTE: Transfer credit of certain courses (especially Science and Math) may be limited by UC or CSU or both. Consult with a counselor.</p>	<p>AREA E LIFE-LONG LEARNING AND SELF-DEVELOPMENT</p> <p>1. One unit of Physical Education activity course</p> <p>2. Two units from:</p> <p>AH 3 The Person in the Life Cycle (3) AH 11 Nutrition (3) BIO 11 Nutrition (3) » CD 2 Early Childhood Development (3) » CD 3 Child Growth and Development During the School Years (3) GUID 1 Self-Assessment and Career Development (2) GUID 6 Life Skills for Higher Education (2) HE 1 Health Education (3) HE 2 Human Sexuality (3) □ PSYC 2 Early Childhood Development (3) □ PSYC 3 Child Growth and Development During the School Years (3) PSYC 5 Self-Assessment and Career Development (2) PSYC 41 Psychology of Adjustment (2) SOC 21 Marriage and the Family (3)</p>
<p>Two requirements: select one course from Requirement 1 and select 2 courses from Requirement 2.</p> <p>9 semester units or 12-15 quarter units</p> <p>Requirement 1:</p> <p>HIST 1 U.S. Hist through Reconstruction (3) HIST 2 U.S. Hist Reconstruction to the Present (3) POLS 1 Intro to American Government (3)</p>		

General Information

Adding and Dropping Classes

Adding Classes: The deadline for adding classes is listed in the schedule. Students should plan to use add codes as soon as they receive them from their instructor, but no later than the add deadline. Add codes expire on the last day to add and cannot be used after that time. Letters from instructors will not be accepted and it is the student's responsibility to ensure that s/he is officially registered for classes. **No exceptions!**

Instructors are to check the roster at the beginning of each class meeting to confirm that the students attending are enrolled. Faculty should ensure that all active students complete the registration process by the deadline.

It is the student's responsibility to make sure he/she is officially registered for classes. Registration status can be viewed on MyGav online (my.gavilan.edu) or by asking the instructor to verify the student name on his/her official roster, or by visiting the Admissions & Records Office or the Hollister or Morgan Hill sites.

Dropping Classes: Students may withdraw from a course by submitting a drop card to Admissions & Records or by completing the drop process via self-service Banner. Click on the Add or Drop Classes link (under Registration Tools) on the Student Tab of MyGAV.

Withdrawal Policy: The following grading practices apply when withdrawing from a course:

- A student who withdraws from a course prior to 30% of the class meetings being held will receive no grade of record.
- A student may withdraw from a course and receive a grade of "W" prior to completion of 75% of the class meetings for the course; thereafter, the student will receive whatever grade they would have earned, based upon the entire semester's work.
- A student may withdraw from a course up to four times and receive a grade of "W"; after a fourth "W", the student will receive the grade they would have earned, based upon the entire semester's work.
- A withdrawal may be excluded from the four-time maximum limit in the case of extenuating circumstances such as natural disasters or other circumstances beyond the control of the student including verified cases of accident or illness.

Course Conflicts: Students with class conflicts must have a note from 1) either both instructors stating they are aware of the conflict or 2) the instructor of the class the student will leave early/arrive late. The note must state what steps will be taken to make up time/work or if there are no conflicting problems.

Attendance Students who fail to attend the first class session may be dropped by the instructor in order to admit waiting students. However, it is the student's responsibility to drop a course she or he stops attending and the student should not assume that the

instructor will do so. Students MUST officially withdraw from a class before the refund deadline in order to receive a refund, even if they have never attended the class. Students can withdraw from class on MyGav, or by filling out a pink drop card and submitting it at the Admissions & Records Office, or at the Hollister or Morgan Hill sites.

Generally, students who miss both the first and second class meetings, without making prior arrangements with the instructor, can be dropped at the instructor's discretion. It is not certain that you will be dropped in this instance, but the instructor has the right to make this choice. It is always the responsibility of the student to verify whether they have been officially dropped from the course.

Advisories Course advisory is recommended preparation for a course. It is not a prerequisite to taking a course but is strongly suggested that the advisory be met prior to enrollment as success in the course may depend upon having that skill or knowledge level. For example, a course advisory that reads "to be eligible for English 250 and English 260 in order to enroll in Psychology 1A" strongly recommends that you have successfully completed (with a "C" grade or better or a "credit") the previous courses, English 440 and English 420. This becomes critical in being able to read and understand college textbooks.

Campus Safety and Crime Statistics

Contact the Gavilan College Security Department at 408-710-7490 (or dial "10" from any campus extension) to report criminal or potential criminal activity.

Campus safety information and crime statistics are available online at www.gavilan.edu/safety. If you would like a hard copy of this information, copies are available at the Campus Security office (S/F bldg.) or call 408-848-4703 to have a copy mailed to you.

Course Repetition There are limitations on the number of times a student may repeat a course. All courses listed in this publication with no repeat notation following the description may be repeated once without filing a petition if a grade of D, F, NC or NP was earned. A student may file a petition to repeat a course a second time if a grade of D, F, NC or NP is earned again. To file a petition, the student must meet with a counselor to evaluate circumstances and receive written approval. The student's transcript and grade point average will reflect the last grade the student receives in the course. A student may petition to repeat the course a third time by filing a Request to Repeat a Course Under Special Circumstances and by providing the necessary documentation to support the special circumstances claim. Grades and grade points under this provision will not be computed in the grade point average.

To repeat a course in which the student has received a final grade of "C" or better, a student must file a Request to Repeat a Course Under Special Circumstances prior to registering for the course again. Units and grade points for the repeated course are not computed in the grade point average unless the course is being repeated to meet legally mandated training

requirements as a condition of continued paid or volunteer employment. This request must be approved by a counselor. For more information about course repetition, see the Gavilan College Catalog.

Pass/No Pass, Letter Grade Option

For some courses, students have the option of selecting a final grade of Pass/No Pass or a traditional letter grade of "A", "B", "C", etc. Review the course description in this schedule to determine which courses are designated as having this grading option.

Before selecting a grading option, students should consider the following:

- Once the option has been selected, the student's decision is final and irreversible.
- To select one option over another, a student must complete the Grading Option form and file it with the Admissions & Records Office or indicate a preference when registering online prior to the NRS (No Record Shown) date for the course. This date is either the end of the fourth week (for a semester-long course) or 30% of the course meetings (for a short-term or early start course.)
- If the student opts for a P/NP final grade, the units are not included in the semester GPA but are considered for the purposes of academic and progress probation and dismissal.
- A P/NP grade is not used in consideration of honors.
- A total of 20 units of P/NP graded units (not including those courses required by the major which are designated P/NP only) may be applied to an Associates's Degree or Certificate.
- The student should carefully consider the transferability of P/NP units to other institutions. Some universities may not accept any pass/no pass courses and others limit the amount of pass/no pass units that will be accepted. Please consult your counselor before selecting the pass/no pass option.

Prerequisites and Co-requisites A **prerequisite** is a course or skill level that is required before you can enroll in another course. For example, English 250 is a prerequisite for English 1A. Courses used to meet prerequisite requirements must have been completed with a "C" grade or better or "Pass". A **co-requisite** is a set of courses that you must take at the same time.

If you believe that you have the equivalent of the prerequisite through another means (courses at another college, AP tests, work experience, etc.) speak with your counselor.

Challenging a Prerequisite: Students who have reason to believe that they have already fulfilled a prerequisite, or that a prerequisite has been improperly established or implemented, may challenge the prerequisite. The student is responsible to provide compelling evidence to substantiate the challenge claim. Challenge forms are available at the Admissions and Records Office and must be completed and returned to the Vice President of Instruction prior to the first day of classes.

The challenge will be reviewed and a decision made within five working days or the student shall be allowed to enroll in the course, provided there were seats available at the time the form was filed. However, the student may enroll in the challenged class (if there are seats available) immediately after filing the form with the Vice President of Instruction by presenting a copy of the Prerequisite Challenge Form at registration. If the challenge is not upheld, the student must drop the course and may apply for a refund of fees. For further information regarding the prerequisite challenge, contact a counselor.

Transcripts of a student's permanent academic record are released ONLY with written authorization of the student. Telephone requests will not be accepted. The first two copies are free; there is a \$4 charge for each copy thereafter. Transcripts are normally sent out within ten business days of the request. This response time may be longer during busy periods such as the first two weeks of a new semester. Urgent requests cannot be honored during the late registration period but can normally be produced within 48 hours at a cost of \$7 per copy.

Unofficial transcripts are available to students on MyGAV.

Policies & Procedures

College policies and procedures are available by accessing the Gavilan College website at www.gavilan.edu or by visiting the office of the Vice President of Student Services (SC130).

Academic Freedom It shall be the policy of Gavilan College to maintain and encourage full freedom for its faculty to teach, research and pursue knowledge subject to the applicable provisions of law.

In the exercise of this freedom the faculty member may, as provided in the U.S. and California Constitutions and other applicable laws, discuss his/her own subject or area of competence in the classroom, as well as any other relevant matters, including controversial matters, so long as he/she distinguishes between personal opinions and factual information.

- Faculty shall be free from unlawful harassment or from unlawful interference or restrictions based on political views.
- Faculty shall be free from any and all forms of electronic or other listening or recording devices, except with his/her express and non-continuing consent, except where allowed otherwise by law.
- The Board shall not unlawfully inquire into, nor predicate any adverse action upon a faculty member's personal, political or organizational activities or preferences.
- The Board shall not interfere with a faculty member's freedom of speech or use of materials in any teaching assignment, except as allowed by law.

The intent is to allow those activities protected by constitutional freedom of speech and other forms of academic freedom protected by the laws of the State of

California and the laws of the United States.

Disabilities

AMERICAN'S WITH DISABILITIES ACT (ADA)

COMPLIANCE: If you have a verified disability and need academic materials in an alternate format or other services, contact the Disability Resource Center at 408-848-4865 or the Vice President of Student Services at 408-848-4738 for assistance.

RESOURCES FOR STUDENTS WITH

DISABILITIES: Students requiring academic or physical accommodations because of visual, physical, learning and/or other verified disabilities should contact the Disability Resource Center at 408-848-4865.

Discrimination

PROHIBITION OF HARASSMENT AND HATE

CRIMES (Reference: Education Code sections 212.5; 66252; 66281.5): The district is committed to providing an academic and work environment that respects the dignity of individuals and groups. The district shall be free of sexual harassment and all forms of sexual intimidation and exploitation. It shall also be free of other unlawful harassment and hate crimes, including those which are based on any of the following statuses; race, color, religion, ancestry, national origin, disability, sex (i.e., gender), sexual orientation, or the perception that a person has one or more of the foregoing characteristics.

NON-DISCRIMINATION: The district is committed to equal opportunity in educational programs, employment, and all access to institutional programs and activities.

TITLE VI, TITLE IX, AND ADA/SECTION 504/508:

To file complaints in the following areas please contact the Equal Opportunity Officer, Joseph D. Keeler, Vice President of Administrative Services, HR101 (408-848-4731). or Jim Bowers, the Director of Human Resources, HR103 (408-848-4753).

The areas are: 1) Civil rights complaints (Title VI), 2) Gender equity, sex discrimination/harassment complaints (Title IX) and 3) Persons with disabilities discrimination complaints (ADA/Section 504/508).

Drug Free Schools and Campuses

Act District policy AP 3550 prohibits "the use, distribution, sale or possession of alcohol, narcotics, dangerous or illegal drugs or other controlled substances, as defined in California statutes, on district property or at any function sponsored by the district." Gavilan College complies with the Drug-Free Schools and Campuses Act of 1989 and the Drug-Free Workplace Act of 1988.

The college recognizes the legal drinking age of 21 years and enforces all state laws regulating the use of alcoholic beverages. All members of the campus community are subject to disciplinary action and/or criminal prosecution for the on-campus possession, use, sale or distribution (by either sale or gift) of any quantity of inappropriate prescription drugs, or controlled substances as defined by the State of California Health and Safety Code. Students found

to be in violation of this policy may be subject to the Standards of Student Conduct and Discipline Procedures. If warranted, employees will also be subject to disciplinary sanction.

For Free Confidential Assistance:

On-Campus:

- Counseling Center, 408-848-4723
- Student Health Services, 408-848-4791

Off-Campus:

- Alcoholics Anonymous, 408-374-8511; www.AASanJose.org
- Narcotics Anonymous, 408-998-4200
- National Council on Alcoholism & Drug Dependence 408-292-7292

Further detailed information on the risks associated with the use of alcohol and other drugs may be obtained from the Gavilan College website: www.gavilan.edu/health.

Health Consequences:

- Impaired learning due to poor concentration, fatigue, drowsiness, anxiety, altered perception, confusion, indifference, depersonalization, memory loss, panic attacks and drug-induced psychosis.
- Impaired judgment leading to driving under the influence of alcohol/other drugs, accidents, violent and abusive behavior, criminal acts, financial troubles, unwanted pregnancy, sexually transmitted diseases, acquaintance rape, attempted or accomplished suicide, permanent injury or death as a result of substance overdose.
- The use of intravenous drugs can result in hepatitis, tetanus, abscesses, and AIDS.
- The use of stimulants can lead to cardiac fibrillation, heart attack, seizures, respiratory arrest and death.
- The most common negative health consequences from occasional drinking are trauma incidents such as auto accidents and violent behavior which involve both the drinker and non-drinking victims.
- Long-term alcohol abuse can cause brain damage, cirrhosis of the liver, hepatitis, permanent coordination loss, ulcer disease, gastritis, pancreatitis, heart disease, stroke, anemia, sexual dysfunction, cancers and many other health problems.

Legal Sanctions: As a student, if you are under the influence of alcohol and/or other drugs, or if you are discovered selling or dispensing drugs on campus or at any college function, you can be suspended, expelled and criminally prosecuted.

If you are an employee at Gavilan College, you may be placed on probation, terminated and criminally prosecuted for the use, sale or possession of illegal drugs and/or alcohol on campus, or at college sponsored events.

For a first offense of driving under the influence of alcohol and/or drugs, you may serve 96 hours to six months in jail and pay a fine. It is unlawful for anyone with a blood alcohol content (BAC) level of .08 percent or above to drive a motor vehicle or ride a bicycle on a

Gavilan's Grade Policy

Grade	GPA	Definition
A	4	Excellent
A-	3.7	Excellent
B+	3.3	Good
B	3	Good
B-	2.7	Good
C+	2.3	Satisfactory
C	2	Satisfactory
D	1	Passing, Less Than Satisfactory
F	0	Failing
P*	0	Pass - at least satisfactory, units awarded not counted in grade point average or in consideration of honors.
NP*	0	No Pass - less than satisfactory or failing, units not counted in grade point average.
I	0	Incomplete - incomplete academic work for unforeseeable, emergency and justifiable reasons after the last day to withdraw with a "W". Request for this grade must be initiated by the student. Work to be completed must not involve further class attendance or instruction. The Incomplete must be made up during the next term of attendance, summer excluded, within the next year.
W	0	Withdraw - withdrew from class after the NRS (No Record Shown) period and before the W deadline. Students withdrawing from courses after the W deadline must be awarded a letter grade or, if appropriate, request an incomplete (see above.)
MW	0	Military Withdrawal

* To be used ONLY if final grade for a course is designated Pass/No Pass

highway. For pot or marijuana (1 oz. or less), you can be fined up to \$100 and receive a criminal citation.

- For possession of marijuana (more than 1 oz.) you may receive up to 6 months in county jail, up to a \$500 fine, or both.
- For possession of cocaine you can be imprisoned in a state prison.
- For sales of any illegal drug you can be imprisoned in a state prison.
- Any person under the age of 21 years who has any alcoholic beverage in his or her possession on any street or highway or in any public place can be convicted of a misdemeanor.
- It is a misdemeanor crime to sell, give or furnish alcohol to anyone under 21 years of age.
- Carriers of motor vehicle insurance can increase premiums, cancel or deny renewal as a result of driving-under-the-influence convictions.

Family Educational Rights and Privacy

In compliance with the Federal Family Education Rights and Privacy Act of 1974 (also known as the Buckley Amendment) and California Title V regulations (SB 182), Gavilan has adopted the following policy:

- Official academic, discipline and other necessary records are maintained on all students who have applied to attend Gavilan College.
- These records are maintained by and in the Admissions & Records Office and the Office of the Vice President of Student Services.
- These records will be released only upon the written authorization of the student upon payment of any or all fees and charges due the college, except as provided by law. Unless otherwise directed, the following directory of information may be released by Gavilan without written consent of the student:
 - name of the student
 - dates of attendance at Gavilan
 - date of graduation and degree or certificate awarded

Students who do not wish to have the above information released as directory information may notify the Admissions & Records Office in writing within the first week of each term. Copies of the complete federal and state regulations are available in the Vice President of Student Services Office and may be reviewed by students by appointment.

Illegal Distribution of Copyrighted Materials

Gavilan College students are prohibited from using the college's computers and information network to illegally download or share music, video, and all other copyrighted intellectual property. Gavilan College supports the Higher Education opportunity Act and Digital Millennium Copyright Act, including efforts to eliminate the illegal distribution of copyrighted material. Illegal forms of downloading and file sharing as well as the unauthorized distribution of copyrighted materials are violations of the law and Board Policy as contained in the Standards of Student Conduct and may subject a student to academic and/or disciplinary sanctions from the college as well as criminal and civil penalties, including a lawsuit by the Recording Industry Association of America (RIAA).

Open Enrollment Unless specifically exempted by statute, every course, course section or class, the average daily attendance of which is to be reported for state aid shall be fully open to enrollment and participation by any person who has been admitted to the college and who meets all prerequisites. Class enrollment is limited by size of facility and program content. Gavilan College is in compliance with Section 504 of the Rehabilitation Act of 1973 and the Americans with Disabilities Act of 1990.

Parking on Campus Semester permits are available during all registration periods. All vehicles parked on the main campus are required to display a parking permit. Day permits are available from coin-operated machines located in parking lots A, E, H and at the south entrance to campus. Student parking is permitted in Lots A, C, E or H except where restricted to staff, guests, or the disabled. Parking Lot D is reserved for staff and disabled only. Guest parking permits are issued at the Facilities Use Scheduling Department (located in the Security/Facilities Bldg (SF)). Disability parking is available in all lots to those displaying a placard from the California Department of Motor Vehicles.

Parking is enforced by the campus security department and local law enforcement. Student and staff spaces are enforced Mon - Thurs: 7am-10 pm and Fri: 7 am- 5 pm. All other spaces and areas are enforced at all times. A complete list of parking regulations is available outside the Security Office (S/F bldg.).

Sexual Assault is a crime regardless of when or where it occurs, or what the relationship is between the attacker and the victim. Gavilan College is committed to providing a safe environment for students and staff. Reports of sexual misconduct will be thoroughly investigated and the victim informed of the outcome. If you, or someone you know, have been the victim of sexual assault, notify Campus Security at 408-710-7490. Confidential counseling is available on campus through Counseling 408-848-4723 or Student Health Services 408-848-4791.

Off-campus confidential counseling is available at Community Solutions: 408-683-4118; 24-hour crisis line: 1-877-363-7238.

Smoke-Free Buildings (BP 6500) Smoking is prohibited inside all public buildings, within twenty 20 feet of all entrances/exits, operable windows or ventilation air intake. Smoking is also prohibited in all college-owned vehicles. Tobacco products shall not be sold on campus either through vending machines or campus establishments. Implementation of the campus smoke-free environment policy will be the responsibility of every student, faculty member, staff person and visitor on campus.

Students' Problem Resolution Process

Procedures have been adopted to allow for student grievances against Gavilan College staff members. The formal policy is available through the Vice President of Student Services Office, in the college catalog and online at www.gavilan.edu. Students are encouraged to resolve issues informally by talking with college staff members.

Vocational English Skills Limited English language skills will not be a barrier to admission to and participation in vocational education programs.

SPRING CLASSES

CRN Type Room Instructor Hrs. Units Days Begin-End

ACCOUNTING

ACCT 20 Financial Accounting

Transferable: CSU, UC; CAN:BUS2, BUS SEQ A

An introduction to accounting principles and concepts. The course includes the application of accounting theory to accumulate and summarize financial data. This course has the option of a letter grade or pass/no pass. ADVISORY: Eligible for English 250, English 260 and Mathematics 233. Microsoft Excel or other computer spreadsheet knowledge.

40230 Lec BU118 J Wolowitz 4.6 4.0 TR 0900-1105

 40225 Online J Wolowitz 4.0 Start by going to <http://www.gavilan.edu/disted> You must have an email account to take this course. Unless you have made prior arrangements with the instructor, you MUST log on by 11:59 pm on the first day of the course. Late adds must login within 24 hours of adding this course. If you miss the deadline you may be dropped. For help, contact your instructor or email disted@gavilan.edu.

ACCT 21 Managerial Accounting

Transferable: CSU, UC; CAN:BUS4, BUS SEQ A

This course covers internal uses of accounting information for managerial decision making. Includes coverage of managerial control methods, cost accounting, cost-volume-profit relationships, variable costing, budgeting, and other related topics. This course has the option of a letter grade or pass/no pass. ADVISORY: Accounting 20. Microsoft Excel or other computer spreadsheet knowledge.

40224 Lec BU118 J Wolowitz 3.2 4.0 TR 1120-1240

ARR J Wolowitz 1.0

40232 ARR J Wolowitz 1.0

Lec BU120 J Wolowitz 3.0 4.0 W 0300-0550

ACCT 103 General Office Accounting

Transferable: CSU

This course is designed to prepare students for entry-level office accounting positions. Emphasis is on practical accounting applications. This course has the option of a letter grade or pass/no pass. ADVISORY: Eligible for Mathematics 205.

40211 L/L BU103 R Brown 3.0 2.0 M 0300-0550

ROP course.

ACCT 105 Payroll Accounting

Transferable: CSU

This is an introductory course in payroll accounting. Topics include: payroll laws and regulations, computation of wages and salaries, Social Security taxes, income tax withholding, employer taxes, payroll tax filing and reporting, and other related topics. This course has the option of a letter grade or pass/no pass. ADVISORY: Eligible for Mathematics 205, completion of Accounting 101.

40813 Lec MHG3 R Brown 3.0 3.0 R 0300-0550

ROP course. Above class meets at Morgan Hill Community site.

ACCT 120 Computerized Accounting - QuickBooks

Transferable: CSU

An introduction to computer-assisted accounting. Hands-on use of a microcomputer menu-driven accounting package to do general ledger, sales journal, cash receipts journal, cash payments journal, purchases journal, payroll, receivables, payables and related financial reports. This course has the option of a letter grade or pass/no pass. Repeatable whenever a new software package is adopted. This course is also listed as CSIS 120. ADVISORY: CSIS 1 or CSIS 2 or the equivalent computer experience. ACCT 20 or ACCT 101 or ACCT 103 or ACCT 105 or the equivalent accounting experience.

40214 L/L BU111 R Brown 3.0 2.0 T 0300-0550

ROP course.



Classes

AJ 5	40855	Introduction to Modern International Terrorism
CGD 30	40547	Introduction to Environmental Design
POLS 5	40306	Introduction to Modern International Terrorism
HUM 12	40868	Mexican-American Cultural History
THEA 15	40761	Intro to Design for Stage, Film and Television

CRN Type Room Instructor Hrs. Units Days Begin-End

ACCT 121 Spreadsheet - MS Excel

Transferable: CSU

Introduction to the computer spreadsheet software. A hands-on approach to learning terms, commands, and applications of a spreadsheet program. This course will help prepare students for taking the Excel MOUS (Microsoft Office User Specialist) exams. This course has the option of a letter grade or pass/no pass. May be repeated once for credit when the software changes. Also listed as CSIS 121. ADVISORY: CSIS 1 or CSIS 2 or equivalent computer experience.

40240 Lec HOL3 M Bryson 4.6 2.0 MW 1120-0125
03/21/11 - 05/18/11 Above class meets at the Hollister Briggs site.

40242 Lec HOL3 F Mendez 3.3 2.0 W 0600-0905
03/09/11 - 05/25/11 Above class meets at the Hollister Briggs site. ROP Course

ACCT 190 Occupational Work Experience/Accounting

Transferable: CSU

Occupational work experience for students who have a job related to their major. A training plan is developed cooperatively between the employer, college and student. (P/NP grading) 75 hours per semester paid work = 1 unit. 60 hours non-paid (volunteer) work per semester = 1 unit. May be taken for a maximum total of 16 units. Minimum 2.00 GPA. REQUIRED: Declared vocational major.

Mandatory course orientation for the following classes will be conducted Feb 11: 2-3 pm, March 1: 4:30-5:30 pm, April 12: 12 pm. Meetings will be held in the Student Center-North/South Lounge. Students must attend one of the three meetings. www.gavilan.edu/cwe for assignments and details. Contact Susan Sweeney, CWE Coordinator at ssweeney@gavilan.edu for more information.

40627 Wrk Ex LI101A S Sweeney 1.0

40628 Wrk Ex LI101A S Sweeney 2.0

40629 Wrk Ex LI101A S Sweeney 3.0

40630 Wrk Ex LI101A S Sweeney 4.0

Acting: see Theatre Arts

ADMINISTRATION OF JUSTICE



AJ 5 Introduction to Modern International Terrorism

Transferable: CSU, UC

This course centers on conceptually defining terrorism (all types-foreign and domestic, left and right wing, religious, environmental, and political, state and non-state), tracing the history and beginnings of modern international and domestic terrorism, critically examining the various U.S.-global responses to the 9-11-01 attacks, as well as generally evaluating and assessing how countries and peoples around the world try to cope with, prevent and/or respond to attacks by terrorist organizations, groups, or acts of terrorism perpetrated by nation-states or groups working with nation-states. This class is also listed as POLS 5. This course may be taken for a letter grade or pass/no pass.

40855 Lec PB3 M Turetzky 3.3 3.0 T 0600-0905

AJ 6 Introduction to Conflict Resolution

Transferable: CSU; CSU-GE:D7; GAV-GE:D2

Introduction to Conflict Resolution introduces students to conflict resolution and mediation. Integrating theory and practice, students will assess core concepts about the causes and resolution of conflict, and will practice communication skills for conflict resolution. Students will examine how ethnicity, gender, and class affect power in conflict situations. They will be able to formulate appropriate conflict resolution strategies, and will develop and practice various basic co-mediation skills. This course has the option of a letter grade or pass/no pass. This course is also listed as POLS 6 and PSYC 6 and CMUN 6. ADVISORY: English 250 and English 260.

40328 Lec PB8 L Halper 3.2 3.0 MW 1120-1240

This service learning course section involves community work. See page 19 for more information.

CRN	Type	Room	Instructor	Hrs.	Units	Days	Begin-End
-----	------	------	------------	------	-------	------	-----------

AJ 10 Introduction to the Administration of Justice

Transferable: CSU, UC; GAV-GE:D2; CAN:AJ2

The history and philosophy of justice as it evolved throughout the world; in-depth study of the American system and various sub-systems; roles and role expectations of criminal justice agents in their interrelationships in society; concepts of crime causations, punishments and rehabilitation; ethics, education and training for professionalism in the social system. ADVISORY: Eligible for English 250 and English 260.

40490	Lec	BU120	S Smith	3.2	3.0	MW	1120-1240
40491	Lec	BU120	S Smith	3.2	3.0	TR	0230-0350

AJ 12 Criminal Procedures

Transferable: CSU

Legal processes from pre-arrest, arrest through trial, sentencing and correctional procedures; a review of the history of case and common law; conceptual interpretations of law as reflected in court decisions; a study of case law methodology and case research as the decisions impact upon the procedures of the justice system. ADVISORY: AJ 10; Eligible for English 250 and English 260.

40492	Lec	BU118	S Smith	3.2	3.0	MW	0230-0350
-------	-----	-------	---------	-----	-----	----	-----------

AJ 14 Criminal Law

Transferable: CSU, UC; CAN:AJ4

Historical development, philosophy of law and constitutional provisions; definitions, classifications of crime, and their applications to the system of administration of justice; legal research, review of case law, methodology, and concepts of law as a social force. Explores crimes against persons, property, and the state. ADVISORY: AJ 10; Eligible for English 250 and English 260.

40522	Lec	BU120	S Smith	3.2	3.0	MW	0800-0920
-------	-----	-------	---------	-----	-----	----	-----------

AJ 16 Introduction to Evidence

Transferable: CSU

This course covers the origin, development, philosophy and basis of evidence; constitutional and procedural considerations affecting arrest, search and seizure; types of evidence and rules governing admissibility; judicial decisions interpreting individual rights and case studies. In addition to the Federal Rules of Evidence, the course also includes the California law regarding the rules of evidence. ADVISORY: AJ 10 and Eligible for English 250 and English 260.

40523	Lec	MHG12	E Campos	3.0	3.0	T	0945-1240
-------	-----	-------	----------	-----	-----	---	-----------

Above class meets at Morgan Hill Community site.

AJ 18 Community and Human Relations

Transferable: CSU, UC

The relationship of criminal justice agents and the community; causal and symptomatic aspects of community understanding; lack of cooperation and mistrust; study of behavioral causes; ways to develop and maintain amicable relationships. ADVISORY: Eligible for English 250 and English 260.

40528	Lec	BU120	L Jones	3.3	3.0	M	0600-0905
-------	-----	-------	---------	-----	-----	---	-----------

AJ 19 Introduction to Investigation

Transferable: CSU

Fundamentals of investigation; techniques of crime scene search and recording; collection and preservation of physical evidence; modus operandi processes; sources of information; interview and interrogation, and follow-up investigation. ADVISORY: Eligible for English 250 and English 260.

40534	Lec	LS106	L Jones	3.3	3.0	W	0600-0905
-------	-----	-------	---------	-----	-----	---	-----------

AJ 21 Narcotics and Drug Abuse

Transferable: CSU

Designed to explore the Administration of Justice system and the development of drug policy and drug problems. This will include drug identification, drug user recognition, drug effects, narcotic enforcement, drug prosecution, and drug treatment, rehabilitation and education. ADVISORY: Eligible for English 250 and English 260.

40535	Lec	BU120	S Smith	3.2	3.0	TR	0945-1105
-------	-----	-------	---------	-----	-----	----	-----------

CRN	Type	Room	Instructor	Hrs.	Units	Days	Begin-End
-----	------	------	------------	------	-------	------	-----------

AJ 176 Criminal Street Gangs

Transferable: CSU

This course is designed to explore historical developments, origins, philosophy and current trends and activities in criminal street gangs within California; explore areas of violence, recruitment, drug use, graffiti and attire; emphasis placed on organization within gangs and racial backgrounds including types of solutions in the criminal justice system use to combat street gangs. ADVISORY: Eligible for English 250 and English 260.

40940	Lec	MHG10	D Pulido	3.3	3.0	T	0630-0935
-------	-----	-------	----------	-----	-----	---	-----------

Above class meets at Morgan Hill Community site.

AJ 190 Occupational Work Experience/Administration of Justice

Transferable: CSU

Occupational work experience for students who have a job related to their major. A training plan is developed cooperatively between the employer, college and student. (P/NP grading) 75 hours per semester paid work = 1 unit. 60 hours non-paid (volunteer) work per semester = 1 unit. May be taken for a maximum total of 16 units. Minimum 2.00 GPA. REQUIRED: Declared vocational major.

Mandatory course orientation for the following classes will be conducted February 11: 2-3 pm, March 1: 4:30-5:30 pm, April 12: 12 pm. Meetings will be held in the Student Center-North/South Lounge. Students must attend one of the three meetings. www.gavilan.edu/cwe for assignments and details. Please contact Susan Sweeney, CWE Coordinator at ssweeney@gavilan.edu for more information.

40725	Wrk Ex	LI101A	S Sweeney		1.0		
40726	Wrk Ex	LI101A	S Sweeney		2.0		
40727	Wrk Ex	LI101A	S Sweeney		3.0		
40728	Wrk Ex	LI101A	S Sweeney		4.0		

ALLIED HEALTH**AH 3 The Person in the Life Cycle**

Transferable: CSU, UC; CSU-GE:E2; GAV-GE:E2, F

Interaction of social, emotional, intellectual, and physical attributes related to the development and realization of human potential across the life span. PREREQUISITE: Eligible for English 250 and English 260.

40049	Lec	LS106	C Logan	3.3	3.0	R	1250-0355
40050	Lec	HOB102	A Dufresne	3.5	3.0	R	0400-0715

AH 11 Nutrition



Transferable: CSU, UC; CSU-GE:E2; GAV-GE:E2, F; CAN:FCS2

This course is designed to meet the needs of the Allied Health student and the general education student alike. The major aim of this course is to help the student acquire relevant information about nutrition which they can use professionally and/or personally. The course will cover the practical aspects of normal nutrition, ways to promote sound eating habits throughout the life cycle, and physiological contribution nutrients make to body structure and function. This course is also listed as BIO 11. PREREQUISITE: Eligible for English 250 and English 260. ADVISORY: Chemistry 30A and Mathematics 205.

40004	Lec	LS106	M Akrop	3.3	3.0	T	1250-0355
-------	-----	-------	---------	-----	-----	---	-----------

ONLINE:

You must have an email account to take the following two courses. Unless you have made prior arrangements with the instructor, you MUST log on by 11:59 pm on the first day of the course. Late adds must login within 24 hours of adding this course. If you miss the deadline you may be dropped. For help, contact your instructor or email disted@gavilan.edu.

	40002	Online	M Akrop	3.0			Start by going to http://www.gavilan.edu/disted
	40014	Online	M Akrop	3.0			Start by going to http://www.gavilan.edu/disted

AH 23 Independent Study

Transferable: CSU

Designed to afford selected students specialized opportunities for exploring areas at the independent study level. The courses may involve extensive library work, research in the community, or special projects. May be repeated until six units of credit are accrued. This course has the option of a letter grade or pass/no pass. REQUIRED: The study outline prepared by the student and the instructor must be filed with the department and the dean.

40762	Ind	HOB104	K Bedell		1.0		
40763	Ind	HOB104	K Bedell		2.0		

CRN Type Room Instructor Hrs. Units Days Begin-End

AH 52 Medical-Surgical Nursing

Transferable: CSU

Course is designed to provide both theoretical and clinical experience in the care of adult, medical-surgical clients. This course will further refine basic nursing skills and introduce more complicated nursing situations. Content includes pre-operative and post-operative care of the client with pain, cancer, and care of the client with disorders of musculoskeletal, integument, gastrointestinal, and respiratory systems. Related pharmacology is included. \$100 course material fee, payable at registration. PREREQUISITE: Completion of AH 51.

40051	L/L	HOB102	L Stubblefield	15.6	11.0	MT	0630-0200
			J Quihuis				
			K Bedell	6.0		WR	0710-1000
			L Stubblefield				

\$100 course materials fee; paid at registration

AH 54 Medical-Surgical/Pediatric Nursing

Transferable: CSU

Course contains two components to provide theoretical and clinical experience in medical surgical and pediatric nursing. Content includes care of clients with disorders of the endocrine and neurosensory systems, mental health, emergency nursing and care of the child, including preventative measures and health teaching. A leadership component is included to prepare the student for the realistic work assignment of the nurse. \$100 course material fee, payable at registration. PREREQUISITE: Completion of AH 51, 52 and 53.

40744	L/L	HOB102	D Amaro	15.6	11.0	MT	0630-0200
	L/L	HOB102	K Bedell	6.0		WR	0100-0400
			D Amaro				
	L/L	HOB102	J Yanda	11.6		MT	0230-1000

\$100 course materials fee; paid at registration

AH 56 Compensatory Nursing Practice

Transferable: CSU

Concepts and principles of the nursing process applied to preventative, remedial, supportive, rehabilitative, and teaching aspects in meeting the health needs of the patient requiring compensatory nursing interventions. Incorporates nursing concepts and experiences with all age groups, including senior adults. \$100 course material fee, payable at registration. PREREQUISITE: Successful completion of AH 55 and an active valid, unrestricted California LVN.

40759	L/L	HOB102	S Turner	16.0	10.0	MT	0600-0200
	L/L		K Bedell	6.0		WR	1010-0100
	L/L	HOB102	K Bedell	15.4		MT	0205-0930
			S Turner				

\$100 course materials fee; paid at registration

AH 171 Advanced Clinical Medical Assisting

Transferable: CSU

Course provides instruction and clinical experience in advanced concepts of clinical medical assisting including specialty procedures and treatments. PREREQUISITE: AH 170 with a grade of C or better or equivalent. Equivalency determined by written and performance exams.

40046	L/L	HOB114	D Comella-Hilde	11.4	6.0	TWR	0100-0430
-------	-----	--------	-----------------	------	-----	-----	-----------

ROP course

AH 180 Fundamentals of Nursing--Convalescent

Transferable: CSU

A course to provide a basic introduction to patient care in the convalescent setting. Emphasizes principles, understanding and skills necessary to perform basic nursing procedures safely and effectively. Includes introduction to health care, planning, safety, infection control, personal care, basic procedures, rehabilitation, nutrition and clients' rights and needs. At the completion of this course students will qualify for state certification as a nursing assistant. PREREQUISITE: Eligible for English 250 and English 260. Clearance from the Department of Health Services (Form HS283), fingerprint card, and health clearance required prior to clinical placement. Health and fingerprint clearance required prior to clinical placement. Uniform, shoes, watch, and stethoscope required. Clinical in Morgan Hill or Hollister, as assigned.

40047	L/L	HOB114	M Machado	7.0		W	0630-0130
	L/L	HOB114	M Machado	6.0	8.0	MT	0900-1200

ROP course

40048	L/L	HOB114	M Machado	7.0	8.0	R	0630-0130
	L/L	HOB114	M Machado	6.0		MT	0900-1200

ROP course

40057	L/L	HOB114	D Reid	7.0	8.0	F	0630-0130
	L/L	HOB114	M Machado	6.0		MT	0900-1200

ROP course



Gavilan College in partnership with the County of Santa Clara offers public safety training for careers in Law Enforcement and Probation. Classes are held at the Harold Holden Justice Training Center in Morgan Hill.

For more information contact:

Linda Mirch, Sr. Training & Staff Development Specialist
Santa Clara County Probation Department
(408) 435-2144

Clay Fontes, Sr. Training Specialist
Santa Clara County Sheriff's Office
(408) 201-7643



Gavilan College is a member of the South Bay Regional Public Safety Training consortium. This consortium is funded by all colleges regionally to provide vocational specific training which may require special facilities, special training conditions or is presented outside of schedules of regular college classes.

Gavilan College has been providing quality Administration of Justice education and training for over 40 years. So, when you want to begin your career in Law Enforcement, you can go to the same place where thousands of Northern California law enforcement officers got their start!

- Careers in:
- Law Enforcement
 - Probation Officer
 - Corrections Officer
 - Fire Technology
 - Dispatcher
 - Juvenile Hall Counselor



www.gavilan.edu/aj
or call (408) 270-6458

Gavilan College is an on-site partner in the

ONE-STOP CAREER CENTER



Job and Career Services
Open to the Public
831-637-JOBS (Hollister)
www.sbcjobs.org

CRN Type Room Instructor Hrs. Units Days Begin-End

AH 190 Occupational Work Experience/Allied Health

Transferable: CSU

Occupational work experience for students who have a job related to their major. A training plan is developed cooperatively between the employer, college and student. (P/NP grading) 75 hours per semester paid work = 1 unit. 60 hours non-paid (volunteer) work per semester = 1 unit. May be taken for a maximum total of 16 units. Minimum 2.00 GPA. REQUIRED: Declared vocational major.

40623	Wrk Ex	HOB114	K Bedell				1.0
40624	Wrk Ex	HOB114	K Bedell				2.0
40625	Wrk Ex	HOB114	K Bedell				3.0
40626	Wrk Ex	HOB114	K Bedell				4.0

Anatomy: see Biological Sciences

CRN	Type	Room	Instructor	Hrs.	Units	Days	Begin-End
-----	------	------	------------	------	-------	------	-----------



ONLINE CLASSES: Start by going to <http://www.gavilan.edu/disted>. You must have an email account to take an online course. Unless you have made prior arrangements with the instructor, you MUST log on by 11:59 pm on the first day of the course. Late adds must login within 24 hours of adding this course. If you miss the deadline you may be dropped. For help, contact your instructor or email disted@gavilan.edu.

ANTHROPOLOGY

ANTH 1 Introduction to Physical Anthropology

Transferable: CSU, UC; CSU-GE:B2, IGETC:5B; GAV-GE:B2; CAN:ANTH2

Explores and analyzes human biological, social and cultural development over the last several million years. The implications of evolutionary theory for the world today are considered. Principal topics are evolutionary theory, Mendelian and molecular genetics, the fossil record, primatology, the nature of human diversity, biocultural analysis of malnutrition, and the question of continuing evolution. **ADVISORY:** English 250, English 260 and Mathematics 205.

40279	Lec	PB3	D Etlar	3.3	3.0	W	0600-0905
-------	-----	-----	---------	-----	-----	---	-----------

	40278	Online	D Klein	3.0	See information above about online classes.		
--	-------	--------	---------	-----	---	--	--

ANTH 2 Introduction to Archaeology

Transferable: CSU, UC; CSU-GE:D1, IGETC:4A; GAV-GE:D2

Introduction to history and development of the concepts and methods of anthropological archaeology, a survey of selected prehistoric cultures, and some training in archaeological survey methods, site recognition, recordation and preservation as well as cultural resource management. **ADVISORY:** Recommended English 250 and English 260.

40280	Lec	PB13	G Michaels	3.2	3.0	TR	1120-1240
-------	-----	------	------------	-----	-----	----	-----------

ANTH 3 Introduction to Cultural Anthropology

Transferable: CSU, UC; CSU-GE:D1, IGETC:4A; GAV-GE:D2, F; CAN:ANTH4

The comparative study of human societies and cultures. Emphasis is placed on the analysis of small scale non-western societies. Specific topics include: the relationship between culture and power; ideas of progress and the nation-state; immigration, kinship, and identity; race and gender; inequality and structural violence; and cross-cultural analysis of religious, political and economic institutions. This course interrogates the relevance of anthropology for understanding the processes of development and globalization. Exploration of the above through ethnographic readings, class discussions, films, short papers and a final research paper based on original fieldwork in a local community. **ADVISORY:** Eligible for English 250 and English 260.

40281	Lec	PB8	G Michaels	3.2	3.0	TR	0945-1105
-------	-----	-----	------------	-----	-----	----	-----------

40282	Lec	PB8	D Klein	3.2	3.0	MW	0230-0350
-------	-----	-----	---------	-----	-----	----	-----------

This service learning course section involves community work. See page 19 for more information.

ANTH 5 Magic/Witchcraft and Religion

Transferable: CSU, UC; CSU-GE:D1, IGETC:4A; GAV-GE:D2

Explores and analyzes, from a cross-cultural and comparative perspective, religious traditions in diverse cultural contexts with particular focus on the effects of globalization on religious beliefs and practices. Cross-cultural analysis of the concepts of magic, witchcraft, and religion. Examination of connections among the concepts of race, nation, and religion. Exploration of the above through ethnographic readings, class discussions, films, short papers, and a final research paper based on original fieldwork in a local religious or spiritual community. **ADVISORY:** English 250 and English 260.

40283	Lec	PB8	D Klein	3.2	3.0	MW	1250-0210
-------	-----	-----	---------	-----	-----	----	-----------

ART

ART 1A Art History

Transferable: CSU, UC; CSU-GE:C1, IGETC:3A; GAV-GE:C1; CAN:ART2, ART SEQ A

A critical survey of the influences and development of painting, architecture, sculpture, and minor arts from pre-history to the Byzantine/Romanesque eras, including the art of primitive people. **ADVISORY:** Eligible for English 250 and English 260.

40499	Lec	MHG4	B Thomas	3.3	3.0	W	0600-0905
-------	-----	------	----------	-----	-----	---	-----------

Above class meets at Morgan Hill Community site.

	40500	Online	C Horn	3.0	See information above about online classes.		
--	-------	--------	--------	-----	---	--	--

CRN	Type	Room	Instructor	Hrs.	Units	Days	Begin-End
-----	------	------	------------	------	-------	------	-----------

ART 1B Art History

Transferable: CSU, UC; CSU-GE:C1, IGETC:3A; GAV-GE:C1; CAN:ART4, ART SEQ A

The history of western painting, sculpture, architecture and minor arts from the Romanesque, the Gothic and Renaissance eras to the present. **ADVISORY:** Eligible for English 250 and English 260.

40501	Lec	MU101	P Hulin	3.2	3.0	TR	0945-1105
-------	-----	-------	---------	-----	-----	----	-----------

40502	Lec	HOL6	R McGinnis	3.3	3.0	T	0600-0905
-------	-----	------	------------	-----	-----	---	-----------

Above class meets at the Hollister Briggs site.

ART 2A Two-Dimensional Design

Transferable: CSU, UC; CSU-GE:C1; GAV-GE:C1; CAN:ART14

An introduction to the basic elements and principles of two-dimensional design. Lettering and graphics applications of design are included. Traditional and experimental materials and techniques are applied to a variety of individual projects and exercises.

40517	L/L	AR103	J Edberg	6.6	3.0	TR	0810-1115
-------	-----	-------	----------	-----	-----	----	-----------

ART 3A Drawing and Composition

Transferable: CSU, UC; CSU-GE:C1; GAV-GE:C1; CAN:ART8

A course that can teach you how to draw. Students learn basic drawing skills through the exploration of a variety of drawing materials such as pencil, inks, charcoal and pastels; processes include doodling, gesture and schematic drawing.

40518	L/L	AR102	A Rosette	6.6	3.0	MW	0810-1115
-------	-----	-------	-----------	-----	-----	----	-----------

40519	L/L	AR102	J Adkins	6.6	3.0	TR	0230-0535
-------	-----	-------	----------	-----	-----	----	-----------

ART 3B Drawing and Composition

Transferable: CSU, UC; GAV-GE:C1

Drawing in pencil, ink, pastels and variety of experimental materials and processes. Cultural awareness and historical foundations are integrated with classroom explorations of expressive drawing. Students develop a variety of drawing approaches and a greater understanding of personal expression. May be repeated once for credit. This course has the option of a letter grade or pass/no pass. **ADVISORY:** Art 2A or 3A.

40520	L/L	AR102	A Rosette	6.6	3.0	MW	1120-0225
-------	-----	-------	-----------	-----	-----	----	-----------

ART 6 Art Appreciation

Transferable: CSU, UC; CSU-GE:C1, IGETC:3A; GAV-GE:C1

An illustrated lecture course that surveys and introduces the visual arts from historical to contemporary times, and teaches students the basic concepts of seeing and appreciating art. **ADVISORY:** English 250 and English 260.

40521	Lec	AR103	E Martinez	3.3	3.0	T	0600-0905
-------	-----	-------	------------	-----	-----	---	-----------

ART 8A Beginning Photography from Analog to Digital

Transferable: CSU, UC; CSU-GE:C1; GAV-GE:C1; CAN:ART18

A beginning photography course focused on the technical and historical aspects of photography from analog to digital. This course includes the development of personal artistic expression and visual perception through the use of various photographic medium. The course will include lectures and discussions about composition and content, analog and digital camera use, lighting and exposure, various photographic processes, and photographic presentation techniques. Alternative methods, mixed media and experimental forms of photography will also be discussed. Students will be required to provide their own camera, and film.

40524	L/L	AR103	J Edberg	6.6	3.0	TR	1120-0225
-------	-----	-------	----------	-----	-----	----	-----------

ART 10A Cultural History of Ceramics

Transferable: CSU, UC; CSU-GE:C1; GAV-GE:C1, F; CAN:ART6

An introduction to the historical developments and cultural influences of ceramic art. Development of a personal expression is realized through the combination of historical elements, observation and actual creations in clay.

40487	L/L	AR101	J Rekedal	6.6	3.0	MW	0810-1115
-------	-----	-------	-----------	-----	-----	----	-----------

40488	L/L	AR101	K Gonzales	6.6	3.0	TR	0600-0905
-------	-----	-------	------------	-----	-----	----	-----------

CRN Type Room Instructor Hrs. Units Days Begin-End

ART 10B Ceramics

Transferable: CSU, UC; GAV-GE:C1

Emphasis on development of wheel throwing and advanced ceramic techniques. Glaze testing, clay body development, kiln stacking and firing are introduced. May be repeated three times for credit. This course has the option of a letter grade or pass/no pass. ADVISORY: Art 10A

40489	L/L	AR101	J Rekedal	6.6	3.0	MW	1120-0225
40493	L/L	AR101	K Gonzales	6.6	3.0	TR	0600-0905

ART 12B Sculpture

Transferable: CSU, UC; GAV-GE:C1

Continued sculptural development of form and technique using a variety of selected media such as welded and cast metal, ceramics and wood. May be repeated once for credit. This course has the option of a letter grade or pass/no pass. ADVISORY: Art 12A

40494	L/L	AR101	P Hulin	6.6	3.0	TR	1120-0225
-------	-----	-------	---------	-----	-----	----	-----------

ART 13 Three-Dimensional Design

Transferable: CSU, UC; CSU-GE:C1; GAV-GE:C1

A fundamental course focused on the technical and historical aspects of three dimensional design and sculpture. Development of personal artistic expression and visual perception through the use of various sculpting media such as plaster, paper, wood, clay, metal, etc. Introduction to the design elements and principles as they relate to space and form in visual art and design will be studied. ADVISORY: English 250 and English 260.

40495	L/L	AR101	P Hulin	6.6	3.0	TR	1120-0225
-------	-----	-------	---------	-----	-----	----	-----------

ART 14 Beginning Mural Painting

Transferable: CSU, UC; CSU-GE:C1; GAV-GE:C1

Studio practice in the design, methods and materials of mural painting through the production of individual and collaborative murals. The course will also provide a historical survey of mural painting, from pre-historic cave painting to contemporary urban murals, with particular focus on the muralists of Mexico. May be repeated three times for credit. This course has the option of a letter grade or pass/no pass.

40496	Online		A Rosette	3.0			
	Lab	AR102	A Rosette	4.3	F		0900-0105

 This HYBRID lecture/online class will be delivered partially over the Internet. See the online syllabus for details. <http://www.gavilan.edu/disted/>

ART 15A Beginning Painting: Form and Composition

Transferable: CSU, UC; GAV-GE:C1

This is an introductory painting course. Students will study traditional, contemporary and experimental painting techniques using acrylics and/or oils as the primary media. Emphasis will be placed on foundational concepts and approaches including color, form and composition. May be repeated once for credit. This course has the option of a letter grade or pass/no pass. ADVISORY: Art 2A or 3A, or portfolio review of student's work.

40497	L/L	AR102	C Canepa	6.6	3.0	TR	1120-0225
-------	-----	-------	----------	-----	-----	----	-----------

This service learning course section involves community work. See page 19 for more information.

ART 15B Beginning Painting: Imagination and Expression

Transferable: CSU, UC; GAV-GE:C1

This is an introductory painting course. Students will study traditional, contemporary and experimental painting techniques and media. Social, cultural and historical awareness are integrated with classroom explorations of expressive painting. Students develop a variety of painting approaches and a greater understanding of personal expression. May be repeated once for credit. This course has the option of a letter grade or pass/no pass. ADVISORY: Art 2A or Art 3A or Portfolio Review

40498	L/L	AR102	C Canepa	6.6	3.0	TR	1120-0225
-------	-----	-------	----------	-----	-----	----	-----------

Learn to dance with fire!

ART 10A/B CERAMICS



GET INVOLVED!

Help paint murals in your own community!

ART 14 Beginning Mural Painting



This class offers studio practice in the design, methods and production of individual and collaborative murals and a historical survey of mural painting.

Satisfies CSU General Education (Area C-1) and the ARTS Gavilan College graduation requirement (AREA C-1)

CRN Type Room Instructor Hrs. Units Days Begin-End

ART 22 Field Work and Service

Transferable: CSU

Supervised field work within the college and with local agencies. Students serve in useful group activities in leadership roles prescribed for them by faculty or community agencies. A maximum of six units may be completed. This is a pass/no pass course. REQUIRED: Learning contracts must be filled out and signed by the student and the supervising instructor.

40503	Fld Ex	AR101	K Gonzales	1.0			
40504	Fld Ex	AR101	J Edberg	1.0			
40505	Fld Ex	AR101	J Rekedal	1.0			

ART 23 Independent Study

Transferable: CSU

Designed to afford selected students specialized opportunities for exploring areas at the independent study level. The courses may involve extensive library work, research in the community, or special projects. May be repeated until six units of credit are accrued. This course has the option of a letter grade or pass/no pass. REQUIRED: The study outline prepared by the student and the instructor must be filed with the department and the dean.

40507	Ind	AR103	J Edberg	1.0			
40508	Ind	AR103	J Edberg	2.0			
40509	Ind	AR101	J Rekedal	1.0			
40510	Ind	AR101	J Rekedal	2.0			
40512	Ind	AR109	A Rosette	1.0			
40513	Ind	AR109	A Rosette	2.0			
40506	Ind	AR101	K Gonzales	1.0			
40814	Ind	AR101	K Gonzales	2.0			
40511	Ind	AR101	P Hulin	1.0			
40815	Ind	AR101	P Hulin	2.0			
40816	Ind	AR101	C Canepa	1.0			
40817	Ind	AR101	C Canepa	2.0			
40818	Ind	AR101	J Adkins	1.0			
40819	Ind	AR101	J Adkins	2.0			

REGISTER ONLINE ...

Go to www.gavilan.edu and click on the MyGAV icon.

CRN Type Room Instructor Hrs. Units Days Begin-End

CRN Type Room Instructor Hrs. Units Days Begin-End

ONLINE CLASSES: Start by going to <http://www.gavilan.edu/disted>

You must have an email account to take an online course. Unless you have made prior arrangements with the instructor, you MUST log on by 11:59 pm on the first day of the course. Late adds must login within 24 hours of adding this course. If you miss the deadline you may be dropped. For help, contact your instructor or email disted@gavilan.edu.

ART 25A Art Methods

Transferable: CSU; CSU-GE:C1; GAV-GE:C1

Art methods and learning theory for those planning to work with preschool, elementary and secondary school students. Includes art therapy as well as gifted and special learner projects. Two dimensional work in printing, drawing, collage. Also listed as CD 25A.

40514	Online		A Rosette	3.0			
	Lab	AR102	A Rosette	4.6	TR		0810-1015



This HYBRID lecture/online class will be delivered partially over the Internet. See the online syllabus for details. <http://www.gavilan.edu/disted/>

40515	L/L	HOL1	R McGinnis	4.3	3.0	F	0400-0805
	ARR		R McGinnis	2.0			

Above class meets at the Hollister Briggs site.

ART 25B Art Methods

Transferable: CSU; GAV-GE:C1

Art methods, creativity and learning theory for those planning to work with preschool, elementary, and secondary school students. Includes art therapy as well as gifted and special learner projects. Three dimensional work in sculpture, bas relief, mobiles, paper mache', plaster, and various 3-D materials. Also listed as CD 25B.

40516	L/L	HOL1	R McGinnis	4.3	3.0	F	0400-0805
	ARR		R McGinnis	2.0			

Above class meets at the Hollister Briggs site.

ART 74 Advanced PhotoShop

Transferable: CSU; GAV-GE:C1

This course is for the PhotoShop-experienced student and explores PhotoShop's advanced features in depth. Students work on projects, which challenge their creativity and technical ability, and will be encouraged to develop complex projects for the web and for the printed page. May be repeated three times for credit. This course has the option of a letter grade or pass/no pass. This course is also listed as CSIS 74 and DM 74. ADVISORY: CSIS 75 PhotoShop I

40777	Lec	MHG5	R Grzan	3.3	3.0	R	0600-0905
-------	-----	------	---------	-----	-----	---	-----------

Above class meets at Morgan Hill Community site.

ART 75 Photoshop I

Transferable: CSU; GAV-GE:C1

This course is based on the software Adobe Photoshop. Students learn to scan photographs and manipulate them using Photoshop tool box and special effects filters. They will learn to color correct photos; mask image using channels; create duotone, tritone, and quadtone images; prepare photos for use in printing and on the web. This course has the option of a letter grade or pass/no pass. May be repeated three times for credit. ADVISORY: CSIS 124 (Windows Fundamentals), CSIS 2L

40779	L/L	LI128	K Powers	3.3	3.0	M	0320-0625
40781	L/L	MHG5	R Grzan	3.3	3.0	T	0600-0905

Above class meets at Morgan Hill Community site.

ART 76 Digital Illustration

Transferable: CSU; GAV-GE:C1

Illustration techniques using computer Bezier curve-based illustration software tools to do diagrams and graphics for use in art, desktop publishing, web graphics, multimedia, and computer presentations. This basic Illustrator course is focused on the technical and historical aspects of digital design and illustration as well as the development of personal artistic expression and visual perception through the use of the digital illustration medium. The course will include lectures and discussions about color, composition and content, computer and illustration program use, printing and presentation techniques. This course has the option of a letter grade or pass/no pass. This course is also listed as CSIS 76 and DM 76. ADVISORY: CSIS 1 or CSIS 2 or equivalent computer experience.

40783	L/L	LI128	V Fainshtein	3.3	3.0	W	0600-0905
-------	-----	-------	--------------	-----	-----	---	-----------

ART 77 Introduction to Digital Media

Transferable: CSU, UC; GAV-GE:C1

An introduction to the field of digital media, including history, social impact, concepts, career options and industry trends. Applying learned visual and aural design principles, students will explore the use of computer-based tools in the design and production of digital media by creating and editing digital images, sounds, video, animation and text. A comprehensive term project for publication on the web or CD ROM will be required. This course is also listed as CSIS 77 and DM 77. This course has the option of a letter grade or pass/no pass. May be repeated twice for credit. ADVISORY: CSIS 124, CSIS 1, CSIS 2.2L, CSIS 3, or familiarity using the Macintosh or Windows operating systems.

40785	L/L	LI128	R Beede	3.2	3.0	TR	0945-1105
-------	-----	-------	---------	-----	-----	----	-----------

ART 80 Digital Photography

Transferable: CSU, UC; GAV-GE:C1

The study of digital photography from digital camera to the computer-based printer or digital media. Artistic, theoretical, and technical aspects will be considered. Topics include information about types and purchasing of digital cameras; theory, mechanics, and art of digital imagery; digital darkroom; eccentricities of digital photo taking; stitching photos for virtual reality; and preparing digital images for print, World Wide Web and other digital media. This course has the option of a letter grade or pass/no pass. This course is also listed as DM 80 and CSIS 80. ADVISORY: CSIS 1 or CSIS 2/2L or ART 8A or equivalent computer experience.

40788	L/L	LI128	J Edberg	5.4	3.0	MW	1250-0315
-------	-----	-------	----------	-----	-----	----	-----------

ART 85 Web Design I: Dreamweaver

Transferable: CSU; GAV-GE:C1

Basic and intermediate principles of designing Web pages/sites using the Dreamweaver web design software and HTML. Emphasis will be on good design and the use of tables, frames, forms, rollovers, DHTML, XHTML, behaviors, and CSS. Also includes site maintenance and the integration of multimedia components such as graphics, sound, animation, and video. This course is for the content person to design, develop, and maintain effective Web sites. This course is also listed as CSIS 85 and DM 85. This course has the option of a letter grade or pass/no pass. May be repeated twice for credit. ADVISORY: CSIS 6 or basic knowledge of HTML.

	40835	Online	S Lawrence	2.0			See information above about online classes. 02/02/11 - 03/28/11
--	-------	--------	------------	-----	--	--	---

ART 107 Digital Media Design

Transferable: CSU; GAV-GE:C1

Fundamentals of design for visual, time-based, interactive, and sound arts as applied to digital media. Includes basic storytelling, graphic design, information architecture, and human factors. Page layout, scriptwriting, storyboards, and flow charts will be used as tools applicable to the design and development of business presentations, interactive media, educational multimedia, animation, web sites, video games, and film/video. This course has the option of a letter grade or pass/no pass. Also listed as CSIS 107 and DM 107. ADVISORY: CSIS 1 or CSIS 2/2L or equivalent computer experience

40394	Lec	LI128	V Fainshtein	2.8	2.0	W	0320-0550
-------	-----	-------	--------------	-----	-----	---	-----------

ART 108 Digital Media Lab

Transferable: CSU; GAV-GE:C1

Supervised practice and individualized computer assisted learning of software applications and techniques commonly found in the design and production of digital media (e.g., digital art and imaging, digital photography, digital print, digital audio/video, web design/authoring, DVD/CD ROMs, animation). Supplements lecture courses. Open entry/exit, so may be added at anytime during the semester. This is a pass/no pass course. May be repeated three times for credit. Also listed as DM 108 and CSIS 108. ADVISORY: CSIS 1 or CSIS 2/2L or equivalent computer experience.

40832	Lab	LI128	R Beede		1.0		
-------	-----	-------	---------	--	-----	--	--

Note: See instructor

CRN Type Room Instructor Hrs. Units Days Begin-End

ART 110 Interactive Animation: Flash

Transferable: CSU; GAV-GE:C1

The production of vector graphics, animation, and interactive multimedia in Shockwave-Flash format for web pages and other digital media. Design of highly interactive web site interfaces and animated games using Flash actions (scripting). Useful for web designers/developers, animators, and multimedia authors. This course has the option of a letter grade or pass/no pass. Also listed as CSIS 110 and DM 110. May be repeated three times for credit. ADVISORY: CSIS 1, CSIS 2/2L, CSIS 124 or basic computer knowledge.

40475 L/L LI128 R Beede 3.2 3.0 MW 1120-1240

ART 113 Introduction to Digital Video

Transferable: CSU; GAV-GE:C1

Introduction to the aesthetic and technical aspects of digital video recording, non-linear editing, special effect generation, and production of video (and associated audio) using the personal computer equipped with specialized software such as iMovie, Final Cut Pro, and After Effects. Also considered will be the preparation of digital video for use in interactive media such as CD, DVD, and the World Wide Web. Students will produce a final digital video project on DVD. This course has the option of a letter grade or pass/no pass. May be repeated two times for credit. Also listed as CSIS 113 and DM 113. ADVISORY: CSIS 1 or CSIS 2/2L or equivalent computer experience.

40482 L/L LI128 R Beede 3.2 3.0 MW 0945-1105

ART 117 Visual Effects-Motion Graphics

Transferable: CSU, UC; GAV-GE:C1

Study of the design of visual effects and motion graphics used in digital video, film, web, multimedia, and interactive games. Includes video/graphics compositing techniques, 2D animation, basic 3D animation, and effects commonly done in digital post-production. Software such as Adobe After Effects and Apple's Motion and Shake will be used. May be repeated 3 times for credit. This course has the option of a letter grade or pass/no pass. This course is also listed as CSIS 117 and DM 117. ADVISORY: DM/ART/CSIS 113 or DM/ART/CSIS 140 or DM/ART/CSIS 77 or THEA 17A or basic knowledge of digital video/film editing.

40485 L/L LI128 R Beede 3.2 3.0 TR 1120-1240

ART 140 Basic Digital Film/Video Production

Transferable: CSU, UC; GAV-GE:C1

An on-line self-paced course covering the basics of film/video production and post production (editing) using "easy to use" computer software such as Apple's iMovie. Beneficial for students who are producing a video/film project as a requirement for another college course, extra skills development, or for self interest. Completion of the associated class or personal project in DVD format using either personal video equipment or the equipment in the Digital Media Studio is required. May be repeated twice for credit. This course has the option of a letter grade or pass/no pass. This course is also listed as DM 140 and CSIS 140.

40825 Online R Beede 1.0 See info on page 36 about online classes.

ART 190 Occupational Work Experience/Commercial Art

Transferable: CSU; GAV-GE:C1

Occupational work experience for students who have a job related to their major. A training plan is developed cooperatively between the employer, college and student. (P/NP grading) 75 hours per semester paid work = 1 unit. 60 hours non-paid (volunteer) work per semester = 1 unit. May be taken for a maximum total of 16 units. Minimum 2.00 GPA. REQUIRED: Declared vocational major.

Mandatory course orientation for the following classes will be conducted February 11: 2-3 pm, March 1: 4:30-5:30 pm, April 12: 12 pm. Meetings will be held in the Student Center-North/South Lounge. Students must attend one of the three meetings. www.gavilan.edu/cwe for assignments and details. Please contact Susan Sweeney, CWE Coordinator at ssweeney@gavilan.edu for more information.

40842	Wrk Ex	LI101A	S Sweeney	1.0
40843	Wrk Ex	LI101A	S Sweeney	2.0
40844	Wrk Ex	LI101A	S Sweeney	3.0
40846	Wrk Ex	LI101A	S Sweeney	4.0

The Sky is the Limit!

at the Gavilan Aviation Maintenance Technology Program



- Unlimited employment opportunities
- Graduates can earn up to \$30/hour
- Internships available
- Accredited by the Federal Aviation Administration
- Receive both Airframe and Powerplant Licenses in 4 semesters
- Fast and easy commute to training program

For complete program information please contact the Aviation Dept. at the Gavilan College main campus, 5055 Santa Teresa Blvd. (408-852-2861) or contact the Career Technical Education Division at 408-848-4719.

CRN Type Room Instructor Hrs. Units Days Begin-End

ASTRONOMY

ASTR 1 Introduction to General Astronomy

Transferable: CSU, UC; CSU-GE:B1, IGETC:5A; GAV-GE:B1

An introduction to the realm of astronomy and space science. Topics to be covered include the historical development of astronomy, the physics of gravitation and radiation, the solar system, stellar astronomy, galactic and extragalactic astronomy, and cosmology. ADVISORY: Mathematics 205 and eligible for English 250 and English 260.

40429 Lec LS101 J Bumgarner 3.3 3.0 T 0230-0535

40430 Lec MHG4 J Bumgarner 3.3 3.0 T 0630-0935
Above class meets at Morgan Hill Community site.

Athletics: see Physical Education (PE)

AVIATION MAINTENANCE TECHNOLOGY

Aviation classes begin early: Check start dates below.

AMT 101 General Aircraft Technology

Transferable: CSU

This course will provide the student with a thorough understanding of the use of maintenance publications, maintenance forms and records with emphasis on A & P mechanic privileges and limitations. Basic electricity for aircraft from Ohm's Law through transistor theory will be taught as well as ground operation and servicing of aircraft. ADVISORY: Mathematics 205 Basic hand tools required. Details at the first class meeting.

40541 L/L MP129 S STAFF 14.0 7.5 MTWRF 0800-1030
01/13/11 - 05/27/11

AMT 111 Airframe Structures

Transferable: CSU

Aircraft wood, fiberglass construction, fabric covering, testing and repair, aircraft inspection, painting techniques and procedures. Also the study of basic hydraulic systems of anti-skid systems, pneumatic, fixed landing and retractable landing gear systems. Basic aircraft systems familiarization along with advanced laboratory projects from topics covered in AMT 110 are a part of this course. Basic hand tools required. Details at the first class meeting.

40543 L/L MP129 S STAFF 25.0 13.5 MTWRF 1035-0330
01/13/11 - 05/27/11

Campus under construction
ROOM NUMBERS MAY CHANGE!

Check room numbers online before your first class.

CRN Type Room Instructor Hrs. Units Days Begin-End

AMT 121 Aviation Powerplant Systems Technology

Transferable: CSU

The theory of operation, maintenance, repair, and trouble-shooting procedures of powerplant systems and their relationship to the total powerplant package. To include lubrication, electrical, instrument, fuel metering, fire protection, starting, control systems, and the aerodynamics, theory and maintenance of propellers and their control systems. ADVISORY: Successful completion of AMT 120. Basic hand tools required. Details at the first class meeting.

40544 L/L PB15 T Flippen 27.2 14.0 TWRP 0830-0300
01/13/11 - 05/27/11

AMT 123 Independent Study

Transferable: CSU

Designed to afford selected students specialized opportunities for exploring areas at the independent study level. The courses may involve extensive library work, research in the community, or special projects. May be repeated until six units of credit are accrued. This course has the option of a letter grade or pass/no pass. REQUIRED: The study outline prepared by the student and the instructor must be filed with the department and the dean.

40545 Ind MP129 T Flippen 1.0
01/13/11 - 05/27/11

40546 Ind T Flippen 1.0

AMT 190 Occupational Work Experience/Aviation

Transferable: CSU

Occupational work experience for students who have a job related to their major. A training plan is developed cooperatively between the employer, college and student. (P/NP grading) 75 hours per semester paid work = 1 unit. 60 hours non-paid (volunteer) work per semester = 1 unit. May be taken for a maximum total of 16 units. Minimum 2.00 GPA. REQUIRED: Declared vocational major.

Mandatory course orientation for the following classes will be conducted February 11: 2-3 pm, March 1: 4:30-5:30 pm, April 12: 12 pm. Meetings will be held in the Student Center-North/South Lounge. Students must attend one of the three meetings. www.gavilan.edu/cwe for assignments and details. Please contact Susan Sweeney, CWE Coordinator at ssweeney@gavilan.edu for more information.

40768 Wrk Ex LI101A S Sweeney 1.0
40769 Wrk Ex LI101A S Sweeney 2.0
40770 Wrk Ex LI101A S Sweeney 3.0
40771 Wrk Ex LI101A S Sweeney 4.0

Beauty School: see Cosmetology

BIOLOGICAL SCIENCE

BIO 5 General Botany

Transferable: CSU, UC; CSU-GE:B2, B3, IGETC:5B; GAV-GE:B2, B3; CAN:BIOL6, BIOL SEQ A

This course is designed for students majoring in botany and/or its related disciplines. The course includes the study of the ecology, evolution, anatomy, physiology and systematics of plants as well as the use of plants in biotechnology and agriculture. PREREQUISITE: Mathematics 233 with a grade of 'C' or better. ADVISORY: Biological Science 10, eligible for English 250 and English 260.

40447 L/L LS103 R Morales 3.2 4.0 TR 0810-0930
L/L LS103 R Morales 3.3 M 0230-0535

This service learning course section involves community work. See page 19 for more information.

BIO 7 Human Anatomy

Transferable: CSU, UC; CSU-GE:B2, B3, IGETC:5B; GAV-GE:B2, B3; CAN:BIOL10, BIOL SEQ B

A functional approach to the gross and microscopic structure of the major systems of the human body. Includes dissection in lab. A cadaver is observed in this course. PREREQUISITE: Biological Science 10 or 15 with a grade of credit or C or better. ADVISORY: Eligible for English 250, English 260 and Mathematics 205.

40448 L/L LS103 Staff 8.6 4.0 WF 1120-0325
40449 L/L LS103 T Robinson 4.0 4.0 S 0810-1200
L/L LS101 T Robinson 5.8 S 1205-0535

CRN Type Room Instructor Hrs. Units Days Begin-End

BIO 8 General Microbiology

Transferable: CSU, UC; CSU-GE:B2, B3, IGETC:5B; GAV-GE:B2, B3; CAN:BIOL14

An introduction to microbiology with an emphasis on bacteriology. Includes the study of morphology, physiology and classification of microorganisms, a survey of infectious disease, immunology and techniques for culture and control of microorganisms. This course is also listed as Allied Health 8. PREREQUISITE: Biological Science 10 or 15 with a grade of credit or C or better. ADVISORY: Chemistry 30A and Chemistry 30B; Eligible for English 250, English 260 and Mathematics 205.

40450 L/L LS102 P Yuh 8.0 5.0 FS 0110-0450

BIO 9 Human Physiology

Transferable: CSU, UC; CSU-GE:B2, B3, IGETC:5B; GAV-GE:B2, B3; CAN:BIOL12, BIOL SEQ B

A study of the functions of the major organs and organ systems of the human body, emphasizing control at the cellular level, integration of systems and homeostasis of the human body. This course is also listed as Allied Health 9. PREREQUISITE: Biological Science 7 or 15 with a grade of credit or C or better. ADVISORY: Chemistry 30A and Chemistry 30B; eligible for English 250, English 260 and Mathematics 205.

40451 Lec LS101 M McKenna 4.6 5.0 WF 1100-0105
Lab LS103 M McKenna 3.3 R 0940-1245
40452 L/L LS101 M McKenna 4.6 5.0 WF 1100-0105
Lab LS103 M Smith 3.2 R 0350-0654
40453 Lec LS101 M McKenna 4.6 5.0 WF 1100-0105
Lab LS103 M McKenna 3.2 R 1246-0349
40454 L/L LS101 M Smith 3.3 5.0 T 0655-1000
L/L LS101 M Smith 1.0 T 0600-0650
L/L LS103 M Smith 3.3 R 0655-1000

BIO 10 Principles of Biology

Transferable: CSU, UC; CSU-GE:B2, B3, IGETC:5B; GAV-GE:B2, B3

An introductory biology course covering functions at the cellular and organismal levels. Includes study of the basic principles of metabolism, heredity, evolution and ecology. Primarily for non-biological science majors. ADVISORY: Eligible for English 250, English 260 and Mathematics 205.

40434 Lec LS101 S Keys 3.2 4.0 MW 0230-0350
Lab LS102 S Keys 2.3 M 1035-1240
40435 Lec LS101 S Keys 3.2 4.0 MW 0230-0350
Lab LS102 S Keys 2.3 W 1035-1240
40436 Lec LS101 S Keys 3.2 4.0 MW 0230-0350
Lab LS103 S Keys 2.0 F 0910-1105
40437 L/L LS102 A Gemar 5.4 4.0 MW 0630-0855

BIO 11 Nutrition

Transferable: CSU, UC; CSU-GE:E2; GAV-GE:E2, F; CAN:FCS2

This course is designed to meet the needs of the Allied Health student and the general education student alike. The major aim of this course is to help the student acquire relevant information about nutrition which they can use professionally and/or personally. The course will cover the practical aspects of normal nutrition, ways to promote sound eating habits throughout the life cycle, and physiological contribution nutrients make to body structure and function. This course is also listed as Allied Health 11. PREREQUISITE: Eligible for English 250 and English 260 ADVISORY: Chemistry 30A and Mathematics 205

40006 Lec LS106 M Akrop 3.3 3.0 T 1250-0355

ONLINE:

You must have an email account to take the following two courses. Unless you have made prior arrangements with the instructor, you MUST log on by 11:59 pm on the first day of your course. Late adds must login within 24 hours of adding this course. If you miss the deadline you may be dropped. For help, contact your instructor or email disted@gavilan.edu.

40003 Online M Akrop 3.0 Start by going to <http://www.gavilan.edu/disted>
40040 Online M Akrop 3.0 Start by going to <http://www.gavilan.edu/disted>

Don't go to the wrong city

MHG = Morgan Hill Community Center site

HOL = Hollister Briggs Building site

CRN Type Room Instructor Hrs. Units Days Begin-End

BIO 15 Survey of Human Anatomy and Physiology

Transferable: CSU, UC; CSU-GE:B2, B3, IGETC:5B; GAV-GE:B2, B3

An introductory study of the structure and function of the human body. Includes study at the cellular and organ system levels, emphasizing integration of systems. Note that a cadaver will be observed in this course. This course is also listed as Allied Health 15. ADVISORY: Biological Science 10, Eligible for English 250, English 260 and Mathematics 205. Course will include the viewing of a cadaver.

40439	Lec	LS101	L Bach	4.6	5.0	MW	0845-1050
	Lab	LS103	L Bach	3.2		T	0945-1249
40440	Lec	LS101	L Bach	4.6	5.0	MW	0845-1050
	Lab	LS103	L Bach	3.3		T	0230-0535
40442	Online		R Malley		5.0		
	Lab	LS103	R Malley	3.3		T	0600-0905
	 This HYBRID lecture/online class will be delivered partially over the Internet. See the online syllabus for details. http://www.gavilan.edu/disted/						
40443	L/L	LS103	S STAFF	8.0	5.0	MW	0600-0940

BIO 21 Field Ecology

Transferable: CSU

Introduces concepts in ecology, plant and animal identification, natural history, and habitat assessment in a field setting. The class will have a two hour preliminary meeting to prepare for two successive meetings to local habitats. Camping is not required. Outings will be rescheduled in the case of inclement weather. This course has the option of a letter grade or pass/no pass. May be repeated twice for credit. ADVISORY: Eligible for English 250 and Math 205.

40845	Lec	LS102	R Morales	2.3	4.0	R	0630-0835
	01/06/11 - Orientation						
	Lec		R Morales			RFS	0600-1000
	Lec		R Morales			U	0600-0800
	Lec	LS102	R Morales	5.0		F	0900-0200

01/06/11-01/21/11 Above short-term class meets off-campus: Everyone must attend a two hour orientation on January 6th a week before our trip. This class will leave Thursday, January 13th at 6:00am and return Sunday night January 16th, around 8:00pm. Thursday and Friday afternoon will be spent at the Sequoias and Kings Canyon National Park. Friday night Saturday and Sunday morning will be spent with the High Sierra Volunteer Trail Crew.

BIO 23 Independent Study

Transferable: CSU

Designed to afford selected students specialized opportunities for exploring areas at the independent study level. The courses may involve extensive library work, research in the community, or special projects. May be repeated until six units of credit are accrued. This course has the option of a letter grade or pass/no pass. REQUIRED: The study outline prepared by the student and the instructor must be filed with the department and the dean.

40445	Ind	LS116	R Morales		2.0		
40446	Ind	LS116	R Morales		1.0		

BIOTECHNOLOGY

BIOT 104 Seminar in Biotechnology

Transferable: CSU

This course will survey careers in biotechnology and ethical issues in biotechnology.

40455	Lec	PS105	L Bach	2.0	1.0	S	0910-1100
	02/02/11 - 04/02/11						

BIOT 105 Advanced Biotechnology Laboratory

Transferable: CSU

This course is part of the Biotechnology program, and builds on skills learned in Biotechnology 103. Students will learn and apply techniques used in biotechnology research, investigation and production. This course provides hands-on experience with current techniques including DNA isolation and electrophoresis, immunological assays, PCR, cell culture, cloning and gene mapping, DNA extraction and purification, chromatography, and analysis of proteins. PREREQUISITE: BIOT 103, or BIO 1, or equivalent course.

40456	L/L	LS102	R Nguyen	8.0	4.0	TR	0600-1000
-------	-----	-------	----------	-----	-----	----	-----------

Business Accounting: see Accounting

Learn Skills in Biotechnology

Application of living organisms or their products to enhance the human condition.



Offered this semester

BIOT 104 Seminar in Biotechnology

This class will be taught over an eight week period and feature speakers who work and do research in Biotechnology.

BIOT 105 Advanced Biotechnology Laboratory

Learn techniques used in research and forensics, including PCR and DNA fingerprinting.

Note: The pre-requisite for this class has been changed to either BIO1 or BIOT 103.

Biotechnology

Certificate of Achievement (17 units)

- BIOT 103** (4 units)
Biotechnology Lab Skills & Instrumentation
- BIOT 104** (1 unit)
Seminar in Biotechnology
- BIO 10** (4 units)
Principles of Biology
- CHEM 30A** (4 units)
Elementary Chemistry
- CHEM 30B** (4 units)
Elementary Organic & Biochemistry

This certificate in Biotechnology may help prepare you for the biotech field which includes:

- ◆ Environmental testing
- ◆ Forensics
- ◆ Hospitals
- ◆ Plant Pathology
- ◆ Research

CRN Type Room Instructor Hrs. Units Days Begin-End

BUSINESS OFFICE TECHNOLOGY

BOT 112 Business Computations with Machines

Transferable: CSU

Self-paced course in the operation of the electronic printing calculator. This course provides theory and practice in business applications with emphasis on mathematical problem solving. This course has the option of a letter grade or pass/no pass. May be repeated three times for credit. ADVISORY: Eligible for Mathematics 402.

40234	Lab	BU110	S Gaffney		.5		
	This is a self-paced class. Please see instructor for specific instructions.						

BOT 180 Medical Terminology for the Office

Transferable: CSU

This course introduces fundamentals of medical word building used in the health profession (prefixes, word roots, suffixes and abbreviations) as well as review of body systems, with emphasis on analysis, definition, spelling and pronunciation. This course had the option of a letter grade or pass/no pass. ADVISORY: Eligible for English 250 and English 260.

40235	Lec	BU120	D Knapp	3.3	3.0	T	0600-0905
	ROP course.						

BOT 181 Medical Billing - MediSoft

Transferable: CSU

This course in computerized billing procedures for a medical office uses MediSoft software. Students will learn the patient billing features of this software and complete a capstone simulation giving them hands-on realistic medical front office practice. This course has the option of a letter grade or pass/no pass. May be repeated three times for credit. ADVISORY: Eligible for English 250. Some computer experience.

40236	L/L	BU110	D Knapp	3.3	2.0	R	0600-0905
	ROP course.						

CRN	Type	Room	Instructor	Hrs.	Units	Days	Begin-End
-----	------	------	------------	------	-------	------	-----------

BOT 182 Medical Office Procedures

Transferable: CSU

This specialized course includes medical office procedures, patient record management, coding/billing for private/government health insurance programs, and professional ethics. May be repeated three times for credit. This course has the option of a letter grade or pass/no pass. PREREQUISITE: BOT 180 and CSIS 126 with credit or a grade of C or better or experience using Microsoft Word. ADVISORY: Eligible for English 250 and Mathematics 402.

40238	L/L	BU110	D Knapp	3.3	3.0	W	0600-0905
ROP course.							

BOT 190 Occupational Work Experience/Business Office Technology

Transferable: CSU

Occupational work experience for students who have a job related to their major. A training plan is developed cooperatively between the employer, college, and student. (P/NP grading) 75 hours per semester paid work = 1 unit. 60 hours non-paid (volunteer) work per semester = 1 unit. May be taken for a maximum total of 16 units. Minimum 2.00 GPA. REQUIRED: Declared vocational major.

Mandatory course orientation for the following classes will be conducted February 11: 2-3 pm, March 1: 4:30-5:30 pm, April 12: 12 pm. Meetings will be held in the Student Center-North/South Lounge. Students must attend one of the three meetings. www.gavilan.edu/cwe for assignments and details. Please contact Susan Sweeney, CWE Coordinator at ssweeney@gavilan.edu for more information.

40729	Wrk Ex	LI101A	S Sweeney		1.0		
40730	Wrk Ex	LI101A	S Sweeney		2.0		
40731	Wrk Ex	LI101A	S Sweeney		3.0		
40741	Wrk Ex	LI101A	S Sweeney		4.0		

BOT 191A Workplace Skills

Transferable: CSU

Workplace Skills teaches skills vital to workplace success. The topic for 191A is Interpersonal Communication. Need not be taken in sequence. This is a pass/no pass course.

40586	Lec	MHG8	F Mendez	3.9	1.0	F	0900-1235
04/29/11 - 05/27/11 Above class meets at Morgan Hill Community site. ROP course.							

40585	Lec	HOL3	F Mendez	3.9	1.0	M	0600-0935
04/25/11 - 05/23/11 Above class meets at the Hollister Briggs site. ROP course.							

BUSINESS, GENERAL**BUS 1 Fundamentals of Business**

Transferable: CSU, UC; GAV-GE:D2

This course introduces students to business and the array of opportunities that it offers. The course will help students recognize careers that will be of interest to them with consideration of their own skills and aptitudes. Different facets of business will be covered and students will learn about establishing their own business. This course has the option of a letter grade or pass/no pass. Previously listed as GBUS 1. ADVISORY: Eligible for English 250 and English 260.

40266	Lec	BU120	D McCormick	3.2	3.0	MW	0945-1105
-------	-----	-------	-------------	-----	-----	----	-----------

40267	Lec	MHG3	S Kurtz	3.3	3.0	W	0600-0905
Above class meets at Morgan Hill Community site. This service learning course section involves community work. See page 19 for more information.							

BUS 80 Business Law

Transferable: CSU, UC; CAN:BUS12

Introduction to the law applicable to business institutions and their operations; social forces and their effect upon the development of law; sources of law, agencies for enforcement, and court procedure and administration agencies. Substantive law, that law which includes rights and duties, will include contracts, agency employment relationships, torts and crimes. This course has the option of a letter grade or pass/no pass. Previously listed as GBUS 80. ADVISORY: Eligible for English 250 and English 260.

40268	Lec	PB13	S Banks	3.3	3.0	W	0600-0905
-------	-----	------	---------	-----	-----	---	-----------

Ceramics: see Art

CRN	Type	Room	Instructor	Hrs.	Units	Days	Begin-End
-----	------	------	------------	------	-------	------	-----------

CHEMISTRY**CHEM 1B General Chemistry**

Transferable: CSU, UC; CSU-GE:B1, B3, IGETC:5A; GAV-GE:B1, B3; CAN:CHEM4, CHEM SEQ A

This is the second semester of a year-long general chemistry course designed as a continuation of Chemistry 1A. Topics include solutions, thermodynamics, chemical kinetics, the equilibria of acids and bases, solubility systems, complex ions, electrochemistry, the chemistry of metals and nonmetals, as well as nuclear chemistry. PREREQUISITE: Chemistry 1A with a grade of C or better.

40458	Lec	PS105	D Clark	4.2	5.0	MWF	0945-1055
	Lab	PS101	G Burce	3.2		T	0945-1249

CHEM 12B Organic Chemistry

Transferable: CSU, UC; CSU-GE:B1, B3, IGETC:5A; GAV-GE:B1, B3

This is the second semester of a year-long organic chemistry course designed as a continuation of Chemistry 12A. Topics include nomenclature, stereochemistry, mechanism, reactions, and spectroscopic studies of the various organic functional groups. Lecture and laboratory methods will focus on synthesis, isolation, purification, elucidation and identification of organic structures as well as instrumental methods and data interpretation. PREREQUISITE: Chemistry 12A

40457	Lec	LS102	D Clark	3.2	5.0	TR	1250-0210
	Lab	PS101	D Clark	6.6		TR	0230-0535

CHEM 30A Elementary Chemistry

Transferable: CSU, UC; CSU-GE:B1, B3, IGETC:5A; GAV-GE:B1, B3; CAN:CHEM6, CHEM SEQ B

This is a first semester college chemistry course designed for majors preparing to take Chemistry 1A, nursing and allied health students, as well as general education. The course will cover the principles of chemistry including properties of matter, energy, atomic theory, the Periodic Table, stoichiometry, elements and compounds, the properties of bonding, molecular structure, chemical reactions, states of matter, acidity, solutions and gases, as well as an introduction to organic chemistry. ADVISORY: Mathematics 205; eligible for English 250 and English 260.

40459	Lec	PS105	J Dupon	3.3	4.0	T	0600-0905
	Lab	PS101	J Dupon	3.3		R	0600-0905

CHEM 30B Elementary Organic and Biochemistry

Transferable: CSU, UC; CSU-GE:B1, B3, IGETC:5A; GAV-GE:B1, B3; CAN:CHEM8, CHEM SEQ B

This is the second semester of a year-long elementary chemistry course designed as a continuation of Chemistry 30A. It is designed for science majors, nursing and allied health students. The course will cover the principles of organic and biochemistry including hydrocarbons, alcohols, aldehydes and ketones, carboxylic acids, amines and amides, carbohydrates, lipids, proteins and their functions in physiological systems, as well as organic chemical reactions. PREREQUISITE: Chemistry 30A with a grade of C or better.

40460	Lec	PS105	D Clark	3.2	4.0	MW	0810-0930
	Lab	PS101	D Clark	3.2		R	0940-1244

CHILD DEVELOPMENT**CD 1 Principles and Philosophies of Early Childhood Education**

Transferable: CSU

An overview of the developing child, current theories and research within the context of family, school, and community, and an historical perspective on the development of early childhood education. The processes of socialization and identity development will be highlighted showing the importance of respectful, reciprocal relationships that support and empower families. Observations in schools are to be arranged. ADVISORY: Eligible for English 250 and English 260.

40079	Lec	CDC100	P Henrickson	3.2	3.0	MW	1255-0215
-------	-----	--------	--------------	-----	-----	----	-----------

Be Aware

If your goal is a MULTIPLE SUBJECT CREDENTIAL, you may need MATH 12, Math for Elementary Teachers.

CRN Type Room Instructor Hrs. Units Days Begin-End

ONLINE CLASSES: Start by going to <http://www.gavilan.edu/disted>. You must have an email account to take an online course. Unless you have made prior arrangements with the instructor, you **MUST** log on by 11:59 pm on the first day of the course. Late adds must login within 24 hours of adding this course. If you miss the deadline you may be dropped. For help, contact your instructor or email disted@gavilan.edu.

CD 2 Early Child Development

Transferable: CSU, UC; CSU-GE:D9, E, IGETC:4I; GAV-GE:D2
 This course examines typical and atypical development within the psychosocial, cognitive, and physical domains from conception through the preschool years. Upon completion of this course, students will be able to evaluate theories and research of child development and effectively apply and communicate their understanding through observation and evaluation. This course is also listed as PSYC 2. This course has the option of a letter grade or pass/no pass. **ADVISORY:** Eligible for English 1A; transfer students consult with advisor.

40092 Lec MHG4 M Bumgarner 3.2 3.0 MW 0945-1105
 Above class meets at Morgan Hill Community site.

40138 Lec GHS-B1 D Muscari 3.0 3.0 T 0330-0630
 This class is part of the High-Step Program. It will be offered at Gilroy High School, Room B1. This class is open to all students. For more information, see a Gavilan counselor.

40090 Online M Bumgarner 3.0 See information above about online classes.

CD 3 Child Growth and Development During the School Years

Transferable: CSU, UC; CSU-GE:D9, E, IGETC:4I; GAV-GE:D2
 This course examines typical and atypical development within the psychosocial, cognitive, and physical domains from middle childhood through adolescence. Upon completion of this course, students will be able to evaluate theories and research of child development and effectively apply and communicate their understanding through observation and evaluation. This course has the option of a letter grade or pass/no pass. This course is also listed as PSYC 3. **ADVISORY:** Eligible for English 1A; transfer students consult with advisor.

40395 Lec MHG4 M Bumgarner 3.2 3.0 MW 1120-1240
 Above class meets at Morgan Hill Community site.

40143 Lec CHS-B101 J Weiler 3.0 3.0 R 0330-0630
 This class is part of the High Step Program. It will be offered at Christopher High School, Room B101. This class is open to all students. For more information, see a Gavilan counselor.

40396 Lec HOL2 R Brown 3.3 3.0 W 0600-0905
 Above class meets at the Hollister Briggs site.

CD 4 Observing and Assessing Children

Transferable: CSU
 Provides training in a variety of naturalistic and formal observation techniques, and discusses the use of standardized testing in children. Students learn to use formal observation tools, make a case study portfolio and give a parent conference. Observing children in classroom settings is required. This course has the option of a letter grade or pass/no pass. **ADVISORY:** Eligible for English 1A; transfer students consult with advisor.

40158 Lec BU103 J Argel 3.3 3.0 W 0600-0905

CD 5 Child/Family and Community

Transferable: CSU
 An examination of the developing child in a societal context focusing on the interrelationship of family, school and community and emphasizing historical and socio-cultural factors. Discussing patterns of development, childrearing, and the value of education in contemporary American society. Highlights the processes of socialization and identity development, showing the importance of respectful, reciprocal relationships that support and empower families and respond to all children's developmental needs. **ADVISORY:** Eligible for English 250 and English 260.

40161 Lec CDC100 J Weiler 3.2 3.0 TR 1255-0215

40191 Lec BU103 J Hori-Garcia 3.3 3.0 T 0600-0905
 This class is taught in Spanish. (Esta clase se enseña en Español).

CD 6 Games and Rhythms for Children

Transferable: CSU
 Nature, function and organization of physical activities for the preschool and elementary school age child. Emphasis is given to the understanding of psychomotor development and spatial awareness. Designed for those planning to work with children. Also listed as Physical Education 6. This course has the option of a letter grade or pass/no pass. **ADVISORY:** Eligible for English 250 and English 260.

40197 Lec APE120 S Dodd 3.2 3.0 TR 0810-0930

Science Alive Conference

Saturday, February 5
 Hands-on Math, Science and Computer Workshops for Kids (grades 6-8)

Education and Financial Aid Workshops for Parents



www.gavilan.edu/sciencealive



EARLY INTERVENTION ASSISTANT Certificate of Achievement

For students who wish to work as assistants or paraprofessionals in early intervention, early childhood special education, or related child development or special education programs serving children with special needs.



Work with a counselor to develop an educational plan leading to the completion of this certificate.

CRN Type Room Instructor Hrs. Units Days Begin-End

CD 7 Cultural Context of Child and Family in a Diverse Society

Transferable: CSU; CSU-GE:D7; GAV-GE:D2, F
 Examines cultural influences on child-rearing practices, family values, and human development. Perspectives from the social sciences will be used to critique and review theoretical and practical implications of oppression and privilege as they apply to families, schools, and communities, including historical and socio-cultural factors. The processes of socialization and identity development, and the importance of respectful, reciprocal relationships that support and empower families. Self-examination and reflection on issues related to social identity, stereotypes and bias, social and educational access, media and schooling. Also listed as PSYC 7 and ANTH 9. **ADVISORY:** Eligible for English 250 and English 260.

40201 Lec CDC100 J Argel 3.2 3.0 MW 0400-0520

CD 8B Teaching Reading and Writing to Children

Transferable: CSU
 This course is designed to teach prospective teachers how a child learns to read and write successfully in school. Specific techniques will be taught. Students will be expected to work 20 hours with a child or children in order to practice their skills and techniques. This course has the option of a letter grade or pass/no pass. **ADVISORY:** Completion of English 250, English 260 or equivalent.

40203 Lec MHG4 B Malaspina 3.3 3.0 M 0600-0905
 Above class meets at Morgan Hill Community site.

CRN Type Room Instructor Hrs. Units Days Begin-End

 **ONLINE CLASSES:** Start by going to <http://www.gavilan.edu/disted>. You must have an email account to take an online course. Unless you have made prior arrangements with the instructor, you MUST log on by 11:59 pm on the first day of the course. Late adds must login within 24 hours of adding this course. If you miss the deadline you may be dropped. For help, contact your instructor or email disted@gavilan.edu.

CD 11A Administration of Programs for Young Children

Transferable: CSU

The principles and practices of the organization and administration of facilities for preschool aged children. Areas covered include organizational structure, budgeting, personnel policies and practices, records, statistics, reporting, relationship with community resources, regulatory agencies, and parents. ADVISORY: Child Development 1 and 2.

40081	Lec	CDC100	S Alonzo	3.3	3.0	W	0600-0905
-------	-----	--------	----------	-----	-----	---	-----------

CD 11C Supervision of Adults: The Mentor Teacher

Transferable: CSU

A study of the methods and principles of supervising adults in early childhood settings. Emphasis is on the role of the experienced classroom teacher who functions as a "mentor/supervisor" to teachers, aides, and other adults. This course meets the requirements for the State Child Development Permit Matrix: "2 unit adult supervision class" and the Mentor Teacher Program. Lectures, discussions, in class and out of class activities, role-play simulations, readings, individual and group assignments as well as videos and guest presenters will be used. ADVISORY: Prefer that students meet the requirements for the State Child Development Teacher Permit or completion of a college-level course of study in child development or early childhood education, or equivalent, or permission of instructor.

40082	Lec	MHG11	J Smith	3.3	2.0	T	0600-0905
Above class meets at Morgan Hill Community site.							

CD 13 Infant and Toddler Development and Care

Transferable: CSU

Students will study the developmental stages of growth specific to infants and toddlers and learn how to foster positive techniques for nurturing infants and toddlers in group settings. Students will study the RIE philosophy and learn how to observe children in child care and home day care settings. This course has the option of a letter grade or pass/no pass. ADVISORY: Eligible for English 250 and English 260. Child Development 2.

40155	Lec	CDC100	S Alonzo	3.3	3.0	M	0600-0905
-------	-----	--------	----------	-----	-----	---	-----------

CD 14B Behavior Management & Guidance of School Age Children

Transferable: CSU

The nature of children's development stages causes school age children to act in different ways at different ages. This course helps students understand the relationship of development, environment, culture and social circumstances to children's behavior. An overview of guidance theories offers strategies to reinforce positive behaviors, encourage communication & cooperation, and establish age-appropriate and consistent limits in a variety of circumstances. This course has the option of a letter grade or pass/no pass. ADVISORY: English 250, English 260, and CD 3

	40083	Online	M Hoshiko-Haugey	3.0	See information above about online classes.		
---	-------	--------	------------------	-----	---	--	--

CD 18 The Outdoor Classroom

Transferable: CSU

In light of the evidence linking the lack of nature in children's lives to the rise in obesity, attention disorders, and depression, this course will teach participants how to create developmentally appropriate outdoor play and nature learning experiences for children from birth to age eight, ensure that outdoor environments are accessible and safe, and methodically observe and assess children's outdoor play. ADVISORY: Eligible for English 250 and 260.

40084	Lec	CDC100	M Bumgarner	3.3	3.0	T	0600-0905
-------	-----	--------	-------------	-----	-----	---	-----------

CD 19 Introduction to Careers with Children

Transferable: CSU

An overview of Department of Social Services and Department of Education regulations regarding child care workers in California. Self-assessment techniques with emphasis on teacher-child and teacher-adult relationships and personal evaluations. Basic principles of curriculum development and discipline techniques. This course has the option of a letter grade or pass/no pass. ADVISORY: Eligible for English 250 and English 260.

	40085	Online	M Bumgarner	2.0	See information above about online classes.		
---	-------	--------	-------------	-----	---	--	--

CRN Type Room Instructor Hrs. Units Days Begin-End

CD 21 Introduction to Curriculum

Transferable: CSU

This foundational curriculum course presents an overview of knowledge and skills needed for designing curriculum and environments for all young children. Students examine the teacher's role in supporting development, fostering creativity, and modeling a joy of learning for children and parents. Students will design and implement an integrated curriculum based on observation and assessment and emphasizes play, and design learning centers for literacy, social, emotional, sensory, art, perceptual, math, and science learning. Students complete and activity folder and participate in demonstrations and observations. ADVISORY: Eligible for English 250 and English 260.

40142	Lec	CDC100	D Clabaugh	3.2	3.0	TR	1120-1240
-------	-----	--------	------------	-----	-----	----	-----------

CD 25A Art Methods

Transferable: CSU; CSU-GE:C1; GAV-GE:C1

Art methods and learning theory for those planning to work with preschool, elementary and secondary students. Includes art therapy as well as gifted and special learner projects. Two dimensional work in printing, painting, drawing, collage. Also listed as ART 25A.

40820	Online		A Rosette	3.0			
	Lab	AR102	A Rosette	4.6	TR	0810-1015	

 This HYBRID lecture/online class will be delivered partially over the Internet. See the online syllabus for details. <http://www.gavilan.edu/disted/>

40689	L/L	HOL1	R McGinnis	4.3	3.0	F	0400-0805
	ARR		R McGinnis	2.0			
Above class meets at the Hollister Briggs site.							

CD 25B Art Methods

Transferable: CSU; GAV-GE:C1

Art methods, creativity and learning theory for those planning to work with preschool, elementary, and secondary school students. Includes art therapy as well as gifted and special learner projects. Three dimensional work in sculpture, bas relief, mobiles, paper mache', plaster, and various 3-D materials. Also listed as ART 25B.

40690	L/L	HOL1	R McGinnis	4.3	3.0	F	0400-0805
	ARR		R McGinnis	2.0			
Above class meets at the Hollister Briggs site.							

CD 30B Teaching Practicum 2 - Reflective Practice in the Classroom

Transferable: CSU

Continuation of CD 30A with emphasis on assessment, conferencing and planning skills. Completion of 30A and 30B, each with concurrent enrollment in 2-4 units of CD 190, satisfies the associate degree student teaching requirements. ADVISORY: Completion of Child Development CD 30A with a grade of "C" or higher. Concurrent enrollment in at least 2 units of CD 190.

40399	Lec	BU103	P Henrickson	3.3	3.0	R	0600-0905
-------	-----	-------	--------------	-----	-----	---	-----------

CD 31 Tutoring School-Age Children

Transferable: CSU

An introductory course for students who wish to work as tutors in classroom settings. Students will gain and apply skills needed to function within a public school setting and develop effective strategies for helping children learn to read and write. Additionally, students will be encouraged to explore related career options, while developing and practicing social awareness and the ability to learn from field experiences in a self-directed manner. This course has the option of a letter grade or pass/no pass.

	40156	Online	M Bumgarner	1.0	See information above about online classes.		
---	-------	--------	-------------	-----	---	--	--

CD 35 Establishing Positive Behavior in the Classroom

Transferable: CSU

Introduces the student to realistic and effective strategies for guiding all young children's behavior. This course demonstrates best practices for establishing and maintaining age and developmentally-appropriate productive behaviors among all children in a classroom setting. Course topics include environmental, developmental and special needs sources of maladaptive and challenging behaviors, guidelines for selecting and implementing strategies for positive behavior change for all children, and developing healthy communication strategies with families, program staff and children. ADVISORY: Eligible for English 1A.

40157	Lec	CDC100	S Alonzo	3.3	3.0	R	0600-0905
-------	-----	--------	----------	-----	-----	---	-----------

CRN Type Room Instructor Hrs. Units Days Begin-End

CD 190 Occupational Work Experience/Child Development

Transferable: CSU

Occupational work experience for students who have a job related to their work. A training plan is developed cooperatively between the employer, college and student. (P/NP grading) 75 hours per semester paid work = 1 unit. 60 hours non-paid (volunteer) work per semester = 1 unit. May be taken for a maximum total of 16 units. Minimum 2.00 GPA. REQUIRED: Declared vocational major.

For the four following classes: In order to obtain Field Work Credit for the Occupational Work Experience placement, students must enroll in CD30A or 30B.

40086	Wrk Ex	CDC131	P Henrickson	1.0			
40087	Wrk Ex	CDC131	P Henrickson	2.0			
40088	Wrk Ex	CDC131	P Henrickson	3.0			
40089	Wrk Ex	CDC131	P Henrickson	4.0			

COMMUNICATION STUDIES

CMUN 1A Introduction to Public Speaking

Transferable: CSU, UC; CSU-GE:A1, IGETC:1C; GAV-GE:A1; CAN:SPCH4

Basic principles of effective human communication and their function in contemporary public settings; emphasis is on the speech to inform, with special consideration given to fundamental communication skills, including organization, reasoning, explanation and listening. ADVISORY: Eligible for English 250 and English 260.

40540	Lec	HOL1	A Andrade	3.2	3.0	MW	0810-0930
Above class meets at the Hollister Briggs site.							
40532	Lec	PB1	S Giacalone	3.2	3.0	MW	1120-1240
40533	Lec	MHG10	D Cowan	3.2	3.0	TR	1120-1240
Above class meets at Morgan Hill Community site.							
40560	Lec	PB1	D Besson	a 3.2	3.0	TR	1250-0210
40553	Lec	PB1	D Besson	a 3.2	3.0	TR	0230-0350
40537	Lec	PB1	D Besson	a 3.0	3.0	T	0430-0730
40536	Lec	PB1	R Cnuddle	3.3	3.0	W	0600-0905

CMUN 4 Intercultural Communication

Transferable: CSU, UC; CSU-GE:D3, D7, IGETC:4G; GAV-GE:D2, F

This course will explore the dynamics of communication as it applies to people from different cultures. Course content focuses on the application of theory and research to intercultural communication contexts. Increasing the awareness and understanding of diversity, the perception process, culture, verbal and non-verbal communication and the obstacles that prevent one from becoming a competent intercultural communicator will be examined.

40555	Lec	PB1	S Giacalone	3.2	3.0	MW	0810-0930
40556	Lec	PB1	S Giacalone	3.2	3.0	MW	0945-1105

CMUN 5 Fundamentals of Communication Studies

Transferable: CSU, UC; CSU-GE:A1, IGETC:1C; GAV-GE:A1

This course provides instruction and application of theory and practice in various communication contexts including the self concept, interpersonal, interviewing skills, small group dynamics, and public speaking. Emphasis is placed on analytical and organizational skills, listening, nonverbal and verbal communication, and public speaking communication methodology. ADVISORY: English 250 and English 260.

40557	Lec	PB1	E Waddell	3.2	3.0	TR	0810-0930
40558	Lec	PB1	E Waddell	3.3	3.0	R	0600-0905

CMUN 6 Introduction to Conflict Resolution

Transferable: CSU; CSU-GE:D7; GAV-GE:D2

Introduction to Conflict Resolution introduces students to conflict resolution and mediation. Integrating theory and practice, students will assess core concepts about the causes and resolution of conflict, and will practice communication skills for conflict resolution. Students will examine how ethnicity, gender, and class affect power in conflict situations. They will be able to formulate appropriate conflict resolution strategies, and will develop and practice various basic co-mediation skills. This course has the option of a letter grade or pass/no pass. This course is also listed as POLS 6, AJ 6 and PSYC 6. ADVISORY: English 250 and English 260.

40559	Lec	PB8	L Halper	3.2	3.0	MW	1120-1240
This service learning course section involves community work. See page 19 for more information.							

Major in Communication

Now Offering!

- Associate of Arts Degree in Communication Studies
- Certificate of Achievement in Interpersonal Communication
- Certificate of Achievement in Communication Studies

Get started today. Call Denise Besson Silvia at 408-848-4831 or visit www.gavilan.edu/comm.



Profile FACULTY

Shelley Giacalone

Quote about communication: *“Communication is the underlying phenomenon that creates, sustains, and destroys our social worlds. Everything we do in life involves communication.”*

Understanding how communication works can be a powerful way for students to learn how to shape their social worlds. I truly enjoy sharing my love of communication with my students through enriching readings, reflective activities (both inside and outside of class), stimulating writing assignments, analytical group work, practical role-playing scenarios, important skill-building exercises, and dialogic discussions. My teaching style is conversational and discussion-based, as I hope to continually engage my students in intellectually stimulating conversations involving (but not limited to) communication, culture, power, and identity. My overarching teaching goal is to work with students to understand the complex connections among how our learning inside the classroom applies to other aspects of our academic, professional, and personal lives. I look forward to learning with you!

Born and raised in San Jose, CA, I have enjoyed living in the Bay Area throughout most of my life. After my undergraduate years at UCLA, I came back to Northern California to attend San Jose State University and to pursue my Master's of Arts Degree in Speech Communication. Traveling has been a big part of my life, as I have lived in Spain and in Australia and visited several countries around the world. I began teaching at Gavilan in Spring 2006 and then I was hired as a full-time Communication Instructor in 2007.

Quote about teaching at Gavilan: *“I love telling people that I have found my “dream job” at Gavilan, as the students and my colleagues are extraordinary!”*

CRN Type Room Instructor Hrs. Units Days Begin-End

CMUN 8 Interpersonal Communication

Transferable: CSU, UC; CSU-GE:A1, IGETC:1C; GAV-GE:A1

This course studies the communication process in an interpersonal (dyadic) setting. This class will explore the ways in which we can improve our communication with others. Verbal and nonverbal messages, self-concept, cultural differences, gender differences, perception, listening and conflict management will be explored.

40531	Lec	PB1	D Besson-Silvia	3.2	3.0	TR	0945-1105
40561	Lec	PB1	D Besson-Silvia	3.2	3.0	TR	1120-1240

CMUN 10 Small Group Communication

Transferable: CSU, UC; CSU-GE:A1, IGETC:1C; GAV-GE:A1; CAN:SPCH10

An introductory course that develops basic individual reasoning skills, insights and experiences in information-sharing, interacting, decision-making, problem-solving, resolution of disputes and other issues central to group processes. ADVISORY: Eligible for English 250 and English 260.

40526	Lec	MHG10	D Cowan	3.2	3.0	TR	0945-1105
Above class meets at Morgan Hill Community site.							
40530	Lec	HOL6	A Andrade	3.2	3.0	MW	0945-1105
Above class meets at the Hollister Briggs site.							
40527	Lec	PB1	S Giacalone	3.2	3.0	MW	1250-0210
40529	Lec	PB1	S Giacalone	3.0	3.0	M	0230-0530

CMUN 129 Presentation Graphics - MS PowerPoint

Transferable: CSU

This introductory course in presentation graphics will use Microsoft Office's "PowerPoint" software to create a computerized presentation with text and objects. This course has the option of a letter grade or pass/no pass. May be repeated three times for credit. This course is also listed as CSIS 129. ADVISORY: CSIS 126 or word processing skills in the Windows environment.

40822	Lec	BU110	E Venable	1.0			
03/28/11 - 05/20/11 This is a self-paced, open entry class. See instructor for specific instructions.							
40823	Lec	HOL3	M Bryson	4.6	1.0	MW	0900-1105
02/23/11 - 03/16/11 Above class meets at the Hollister Briggs site.							
40824	Lec	HOL3	F Mendez	3.9	1.0	W	0600-0945
02/02/11 - 03/02/11 Above class meets at the Hollister Briggs site. ROP course.							

Computer Art: see ART 48A/B, CGD, CSIS or Digital Media

COMPUTER GRAPHICS AND DESIGN

CGD 4 2D/3D Technical Computer Graphics II

Transferable: CSU

Intermediate computer graphics design course expands skills and concepts introduced in CGD 2. Develops design and graphic skills required to create, explain, model, render, and animate products using a problem solving process and knowledge of ergonomics, materials, design principles and color theories. Projects assigned integrate technology with design and focus upon creating, developing and marketing useful products by developing and visually communicating ideas that are necessary for succeeding in desired design career(s). May be repeated once for credit. ADVISORY: Completion of CGD 2 with a grade of C or better.

40548	L/L	LI126	C McLaughlin	3.2	3.0	TR	0220-0340
ROP course.							

CGD 9 Advanced Computer Graphics for Design Application II

Transferable: CSU

Advanced computer graphics and design course that combines technical computer graphic skills with interdisciplinary design proficiencies including creating computer imagery, transformations, and rendering to create 3D model using geometric primitives, projections for computer animation and data visualization. Includes structural analysis and emphasis on developing products that include ergonomic features and sustainable materials. Work within electronic portfolio demonstrates skills and knowledge of technical graphic design to visualize, develop and present products to meet societal needs. ADVISORY: Satisfactory score on the English placement exam or a grade C or better in English 250, completion of Mathematics 233 or satisfactory Mathematics placement. Completion of CGD 2 and CGD 8 with a grade of C or better. Computer lab work can be done both in lab and off-site.

40549	L/L	LI126	C McLaughlin	3.2	3.0	TR	0220-0340
ROP course.							

CRN Type Room Instructor Hrs. Units Days Begin-End



CGD 30 Introduction to Environmental Design

Transferable: CSU

Develops skills and computer aided design (CAD) skills necessary for designing and producing a set of plans for an array of environmental projects, such as residential remodels, landscape projects, interior design and other small construction projects. Includes introduction to building codes, sustainable design concepts, specifications and other architectural construction document basics necessary for getting permits and entering environmental design careers.

40547	L/L	LI126	C McLaughlin	3.2	3.0	TR	1250-0210
ROP course.							

CGD 110 Computer Graphics Lab

Transferable: CSU

Complements computer graphics and art courses by providing additional competence in software applications, libraries, and graphical user interfaces to support computer graphics and design projects by providing supervised practice and individualized computer assisted learning on software and techniques commonly found in the computer graphic design field. This is an open entry/exit class and may be repeated three times for credit. This course has the option of a letter grade or pass/no pass. ADVISORY: Concurrent enrollment in corresponding computer graphic and design classes. Computer lab work can be done both in lab and off-site.

40550	Lab	LI126	C McLaughlin		1.0		
40551	Lab	LI126	C McLaughlin		2.0		
40552	Lab	LI126	C McLaughlin		3.0		
40554	Lab	LI126	C McLaughlin		4.0		

CGD 190 Occupational Work Experience/Computer Graphics & Design

Transferable: CSU

Occupational work experience for students who have a job related to their major. A training plan is developed cooperatively between the employer, college and student. (P/NP grading) 75 hours per semester paid work = 1 unit. 60 hours non-paid (volunteer) work per semester = 1 unit. May be taken for a maximum total of 16 units. Minimum 2.00 GPA. REQUIRED: Declared vocational major.

Mandatory course orientation for the following classes will be conducted February 11: 2-3 pm, March 1: 4:30-5:30 pm, April 12: 12 pm. Meetings will be held in the Student Center-North/South Lounge. Students must attend one of the three meetings. www.gavilan.edu/cwe for assignments and details. Please contact Susan Sweeney, CWE Coordinator at ssweeney@gavilan.edu for more information.

40764	Wrk Ex	LI101A	S Sweeney		1.0		
40765	Wrk Ex	LI101A	S Sweeney		2.0		
40766	Wrk Ex	LI101A	S Sweeney		3.0		
40767	Wrk Ex	LI101A	S Sweeney		4.0		

COMPUTER SCIENCE & INFORMATION SYSTEMS

CSIS 1 Computer Literacy - MS Office

Transferable: CSU, UC; GAV-GE:E2; CAN:CSCI2

An introduction to terminology, design, operation for the novice user. Student will gain experience using the Internet for searches and email. They will complete projects using various software including word processing, spreadsheets, database, presentation graphics, and integration. This course has the option of a letter grade or pass/no pass. ADVISORY: Eligible for English 250 and English 260; completion of CSIS 122.

40313	Lec	BU111	S Gaffney	4.6	2.0	MW	0900-1105
02/02/11 - 03/23/11 ROP course.							
40387	Lec	BU111	S Gaffney	4.6	2.0	MW	0900-1105
03/28/11 - 05/18/11 ROP course.							
40389	Lec	HOL3	F Thompson	3.0	2.0	R	0600-0905
03/03/11 - 05/19/11 Above class meets at the Hollister Briggs site.							
40388	Lec	BU110	S Gaffney	3.3	2.0	T	0600-0905
03/01/11 - 05/17/11 ROP course.							

CRN Type Room Instructor Hrs. Units Days Begin-End

ONLINE CLASSES: Start by going to <http://www.gavilan.edu/disted>
 You must have an email account to take an online course. Unless you have made prior arrangements with the instructor, you **MUST** log on by 11:59 pm on the first day of the course. Late adds must login within 24 hours of adding this course. If you miss the deadline you may be dropped. For help, contact your instructor or email disted@gavilan.edu.

CSIS 2 Computers in Business - MS Office

Transferable: CSU; GAV-GE:E2; CAN:BUS6

Introduction to computerized business data processing, information management systems, computer hardware, office automation, telecommunications, computer languages, systems analysis and design; hands on experience with common business software packages including word processing, spreadsheets, data base management, presentation graphics as well as systems software and Internet applications. This course has the option of a letter grade or pass/no pass. **ADVISORY:** Eligible for Mathematics 233, English 260 and English 250, and CSIS 122

40566	L/L	BU111	M Bryson	1.6	4.0	F	0945-1105
	Online		E Venable				

H This HYBRID lecture/online class will be delivered partially over the Internet. See the online syllabus for details. <http://www.gavilan.edu/disted/>

40567	L/L	BU111	M Bryson	1.6	4.0	T	0945-1105
	Online		E Venable				

H This HYBRID lecture/online class will be delivered partially over the Internet. See the online syllabus for details. <http://www.gavilan.edu/disted/>

CSIS 2L Computers in Business Lab - MS Office

Transferable: CSU

Computer Lab emphasizing business application in Microsoft Word, Excel, Access, Power Point and Integration. Internet searches are included. This course has the option of a letter grade or pass/no pass. Since supervised repetition and practice enhance skills/proficiencies. This course may be repeated once for credit.

40564	Lab	BU111	M Bryson	1.6	1.0	T	0945-1105
40570	Lab	BU111	M Bryson	1.6	1.0	F	0945-1105
40857	Lab	BU111	F Thompson	3.3	1.0	M	0600-0905

CSIS 6 Web Page Authoring I

Transferable: CSU; GAV-GE:E2

An introduction to using Hypertext Mark-Up Language (HTML) and Extensible HTML (XHTML) to create web pages which can be uploaded and displayed on the World Wide Web. Students will use HTML/XHTML to create web pages with text in various sizes and colors, links to other sites, background color or patterns, graphics, tables and mailto links. Principles of design and color as they apply to screen presentations will be included. This course has the option of a letter grade or pass/no pass. May be repeated three times for credit. Also listed as LIB 6 and DM 6. **ADVISORY:** CSIS 1 or CSIS 2 or CSIS 3/LIB 3 advised.

Q	40572	Online	J Howell	2.0			See information above about online classes. 02/07/11 - 03/25/11
----------	-------	--------	----------	-----	--	--	--

Q	40573	Online	J Howell	2.0			See information above about online classes. 03/28/11 - 05/27/11
----------	-------	--------	----------	-----	--	--	--

CSIS 8 Introduction to the Internet

Transferable: CSU; GAV-GE:E2

This course will provide students the opportunity to learn to use the Internet and the World Wide Web. Topics to be covered include history of the Internet and development of the WWW, web browsers, search engines, tools to develop web pages, how to get connected and local Internet providers. This is a pass/no pass course. May be repeated three times for credit. **ADVISORY:** CSIS 124

40579	Lec	HOL3	M Bryson	4.6	1.0	MW	1120-0125 02/23/11 - 03/16/11 Above class meets at the Hollister Briggs site.
-------	-----	------	----------	-----	-----	----	--

Q	40580	Online	E Venable	1.0			See information above about online classes. 02/07/11 - 03/28/11
----------	-------	--------	-----------	-----	--	--	--

Q	40581	Online	E Venable	1.0			See information above about online classes. 03/21/11 - 05/27/11
----------	-------	--------	-----------	-----	--	--	--

Develop Skills in Environmental Design

while using Revit to prepare CAD/BIM architectural plans



CGD

Sign up for CGD 30 Intro. to Environmental Design

Prepare for careers in:

- Environmental Design
- Civil Engineering
- Interior Design
- Construction
- Architecture

Additional Info:
www.gavilan.edu/cgd

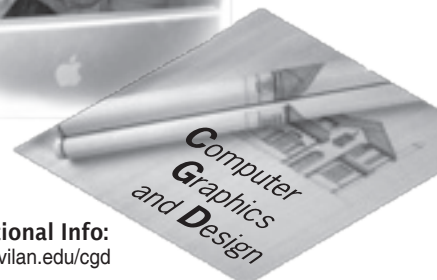

Gav Arts & Events

Log on to <http://www.gavilan.edu/pio/CavArts.html> to see what entertainment and events Gavilan has to offer!



CMAP CHANNELS
 CITYVIEW 17
 GAV-TV 18
 ED-TV 19
 PUBLIC ACCESS 20

CMAP is a non-profit community media center and cable access television station located at Gavilan College in L-139 in Gilroy.

CMAP offers:

- Local Government, Education and Community TV
- Professional equipment and free or low-cost classes in Video Production, Filmmaking, Digital Storytelling, Green Screen and Editing in Final Cut Pro/ to document your life, your community and your stories in multimedia.
- Job training programs

We can train you how to make your own TV & YouTube videos and offer ongoing K-12 digital media classes and camps for kids.

For more information or to get involved, stop by CMAP in L-139, or visit www.cmap.tv for our orientation and class schedule or call 408.846.4983.

Available to residents of Gilroy, Hollister, San Juan Bautista and Morgan Hill, and GAV students.

CRN Type Room Instructor Hrs. Units Days Begin-End

CRN Type Room Instructor Hrs. Units Days Begin-End

 **ONLINE CLASSES:** Start by going to <http://www.gavilan.edu/disted>

You must have an email account to take an online course. Unless you have made prior arrangements with the instructor, you MUST log on by 11:59 pm on the first day of the course. Late adds must login within 24 hours of adding this course. If you miss the deadline you may be dropped. For help, contact your instructor or email disted@gavilan.edu.

CSIS 10 BASIC Programming

Transferable: CSU, UC

This course is an introduction to programming using BASIC. No previous programming background is assumed. This is a good class for those new to programming and recommended for non-programmers that want to take other programming classes. This course has the option of a letter grade or pass/no pass. ADVISORY: CSIS 1 or CSIS 2 or equivalent experience.

40390 Lec LI126 F Thompson 3.2 2.0 TR 0945-1105
03/01/11 - 05/19/11

40391 Lec HOL3 F Thompson 2.6 2.0 F 0945-1205
02/04/11 - 05/20/11 Above class meets at the Hollister Briggs site.

CSIS 23 Independent Study

Transferable: CSU

Designed to afford selected students specialized opportunities for exploring areas at the independent study level. The courses may involve extensive library work, research in the community, or special projects. May be repeated until six units of credit are accrued. This course has the option of a letter grade or pass/no pass. REQUIRED: The study outline prepared by the student and the instructor must be filed with the department and the dean.

40794 Ind MHG8 D Van Tassel 1.0
Above class meets at Morgan Hill Community site.

CSIS 24 Java Programming I

Transferable: CSU, UC

Introduction to Java programming. Includes learning the Java environment, using and creating Java applets, and writing stand-alone applications. Covers the Java environment, object-oriented programming, language basics, classes, interfaces, packages, threads, and exceptions. This course has the option of a letter grade or pass/no pass. ADVISORY: CSIS 45 C++ Programming or equivalent programming experience.

40606 Lec MHG8 D Van Tassel 3.3 4.0 T 0600-0950
Online D Van Tassel

 This HYBRID lecture/online class will be delivered partially over the Internet. See the online syllabus for details. <http://www.gavilan.edu/disted>. Class also meets at Morgan Hill Community site.

 40607 Online D Van Tassel 4.0 See information above about online classes.

CSIS 43 C Programming

Transferable: CSU, UC

This course introduces computer programming using the C programming language. Topics include variable and constant declarations, arithmetic operations, selection, input/output operations, repetition, functions and recursion, arrays, pointers, and other related topics. This course has the option of a letter grade or pass/no pass. ADVISORY: CSIS 10 BASIC Programming, or other programming experience.

40608 Lec LI126 D Van Tassel 3.2 4.0 MW 0945-1105
Online D Van Tassel

 This HYBRID lecture/online class will be delivered partially over the Internet. See the online syllabus for details. <http://www.gavilan.edu/disted/>

 40609 Online D Van Tassel 4.0 See information above about online classes.

CSIS 45 C++ Programming I

Transferable: CSU, UC; GAV-GE:E2; CAN:CSCI18

An introduction to the concepts and methods of computer programming using C++. Students will be introduced to procedural and object-oriented programming design methodology. Topics covered include variable and constant declarations, selection statements, repetition, functions and recursion, arrays, strings, pointers, and an introduction to classes and objects. This course will prepare students for the Programming II class. This course has the option of a letter grade or pass/no pass. ADVISORY: CSIS 10 or equivalent. Math 205 (Elementary Algebra)

40613 L/L LI126 D Van Tassel 3.2 4.0 MW 0945-1105
Online D Van Tassel

 This HYBRID lecture/online class will be delivered partially over the Internet. See the online syllabus for details. <http://www.gavilan.edu/disted/>

 40614 Online D Van Tassel 4.0 See information above about online classes.

CSIS 46 C++ Programming II

Transferable: CSU, UC

This course is a continuation of CSIS 45, intended for students majoring in programming and/or planning to transfer to a 4-year college or university Computer Science program. The course will cover topics discussed in CSIS 45 in more detail. In addition the course will cover more advanced C techniques such as pointers, recursion, and linked lists. Special emphasis will be placed on C++ features such as classes, objects, templates and operator overloading. This course has the option of a letter grade or pass/no pass. ADVISORY: CSIS 45 or CSIS 5, and Mathematics 205.

 40610 Online D Van Tassel 4.0 See information above about online classes.

CSIS 48 UNIX/Linux Operating System

Transferable: CSU, UC

This course will provide the basics of the UNIX/Linux operating system, including the history and the use of UNIX/Linux with hands-on experience using commands and files. Topics to be covered include basic UNIX/Linux commands, text editing, files and directories, electronic mail, pipes and filters, and shell programming. This course has the option of a letter grade or pass/no pass. ADVISORY: CSIS 1 or CSIS 2 or equivalent computer experience.

40611 L/L MHG8 D Van Tassel 4.0 4.0 M 0600-0950
Online D Van Tassel

 This HYBRID lecture/online class will be delivered partially over the Internet. See the online syllabus for details. <http://www.gavilan.edu/disted>. Class also meets at Morgan Hill Community site.

 40612 Online D Van Tassel 4.0 See information above about online classes.

CSIS 54 Perl Programming

Transferable: CSU, UC

Introduction to the interpreted language called PERL, the Practical Extraction and Report Language. Writing of programs that perform various tasks, including text, file and process manipulation. Semantics and syntax of the Perl language, including discussion of the practical kinds of problems that Perl can solve and provides examples. This course has the option of a letter grade or pass/no pass. Concurrent enrollment in CSIS 54L is required. COREQUISITE: CSIS 54L Perl Programming Lab ADVISORY: CSIS 45 C++ Programming or equivalent programming experience.

40853 Lec MHG5 Howell P 3.3 3.0 W 0600-0905
Above class meets at Morgan Hill Community site

CSIS 54L Perl Programming Lab

Transferable: CSU, UC

Supplemental practice in coursework associated with this course is provided. Concurrent enrollment in CSIS 54 is required. COREQUISITE: CSIS 54 Perl Programming

 40856 Online Howell P 1.0 See information above about online classes.

CSIS 74 Advanced PhotoShop

Transferable: CSU; GAV-GE:C1

This course is for the PhotoShop-experienced student and explores PhotoShop's advanced features in depth. Students work on projects, which challenge their creativity and technical ability, and will be encouraged to develop complex projects for the web and for the printed page. May be repeated three times for credit. This course has the option of a letter grade or pass/no pass. This course is also listed as ART 74 and DM 74. ADVISORY: CSIS 75 PhotoShop I

40574 Lec MHG5 R Grzan 3.3 3.0 R 0600-0905
Above class meets at Morgan Hill Community site.

Less Grade Stress!! Many CSIS and BUS classes may be taken for either a letter grade or on a pass/no pass basis. Make your choice when registering or until the NRS deadline (March 3). But remember that you cannot change your mind once you're decided. See Pass/No Pass Grading Option on page 28 for more details.

CRN Type Room Instructor Hrs. Units Days Begin-End

CSIS 75 Photoshop I - Adobe Photoshop

Transferable: CSU; GAV-GE:C1

This course is based on the software application Adobe Photoshop. Students learn to scan photographs and manipulate them using Photoshop tool box and special effects filters. They will learn to correct photos; mask image using channels; create duotone, tritone, and quadtone images; prepare photos for use in printing and on the web. This course has the option of a letter grade or pass/no pass. May be repeated three times for credit. Students who repeat this course will learn new and advanced features. This course is also listed as DM 75. ADVISORY: CSIS 124 (Windows Fundamentals), CSIS 2L

40575 L/L LI128 K Powers 3.3 3.0 M 0320-0625

40576 L/L MHG5 R Grzan 3.3 3.0 T 0600-0905
Above class meets at Morgan Hill Community site.

CSIS 76 Digital Illustration

Transferable: CSU; GAV-GE:C1

Illustration techniques using computer Bezier curve-based illustration software tools to do diagrams and graphics for use in art, desktop publishing, web graphics, multimedia, and computer presentations. This basic Illustrator course is focused on the technical and historical aspects of digital design and illustration as well as the development of personal artistic expression and visual perception through the use of the digital illustration medium. The course will include lectures and discussions about color, composition and content, computer and illustration program use, printing and presentation techniques. This course has the option of a letter grade or pass/no pass. This course is also listed as ART 76 and DM 76. ADVISORY: CSIS 1 or CSIS 2 or equivalent computer experience.

40577 L/L LI128 V Fainshtein 3.3 3.0 W 0600-0905

CSIS 77 Introduction to Digital Media and its Tools

Transferable: CSU, UC; GAV-GE:C1

An introduction to the field of digital media, including history, social impact, concepts, career options and industry trends. Applying learned visual and aural design principles, students will explore the use of computer-based tools in the design and production of digital media by creating and editing digital images, sounds, video, animation, and text. A comprehensive term project for publication on the web or CD ROM will be required. This course is also listed as ART 77 and DM 77. This course has the option of a letter grade or pass/no pass. May be repeated twice for credit. ADVISORY: CSIS 124, CSIS 1, CSIS 2/2L, CSIS 3, or familiarity using the Macintosh or Windows operating system.

40578 L/L LI128 R Beede 3.2 3.0 TR 0945-1105

CSIS 80 Digital Photography

Transferable: CSU, UC; GAV-GE:C1

The study of digital photography from digital camera to the computer-based printer or digital media. Artistic, theoretical, and technical aspects will be considered. Topics include information about types and purchasing of digital cameras; theory, mechanics, and art of digital imagery; digital darkroom; eccentricities of digital photo taking; stitching photos for virtual reality; and preparing digital images for print, World Wide Web and other digital media. This course has the option of a letter grade or pass/no pass. This course is also listed as ART 80 and DM 80. ADVISORY: CSIS 1 or CSIS 2/2L or ART 8A or equivalent computer experience.

40582 L/L LI128 J Edberg 5.4 3.0 MW 1250-0315

CSIS 85 Web Design I: Dreamweaver

Transferable: CSU; GAV-GE:C1

Basic and intermediate principles of designing Web pages/sites using the Dreamweaver web design software and HTML. Emphasis will be on good design and the use of tables, frames, forms, rollovers, DHTML, XHTML, behaviors, and CSS. Also includes site maintenance and the integration of multimedia components such as graphics, sound, animation, and video. This course is for the content person to design, develop, and maintain effective Web sites. This course is also listed as ART 85 and DM 85. This course has the option of a grade or pass/no pass. May be repeated three times for credit. ADVISORY: CSIS 6 or basic knowledge of HTML.

 40583 Online S Lawrence 2.0 See info on page 46 about online classes.
02/02/11 - 03/28/11



Brush Up your Software Skills

Most Computer Applications classes are repeatable.



Offered online

CSIS 48

UNIX/Linux Operating System

4 units

Basic UNIX/Linux commands, test editing, files and directories, electronic pipes and filters.

Transferable: UC and CSU

CRN Type Room Instructor Hrs. Units Days Begin-End

CSIS 107 Digital Media Design

Transferable: CSU

Fundamentals of design for visual, time-based, interactive, and sound arts as applied to digital media. Includes basic storytelling, graphic design, information architecture, and human factors. Page layout, scriptwriting, storyboards, and flow charts will be used as tools applicable to the design and development of business presentations, interactive media, educational multimedia, animation, web sites, video games, and film/video. This course has the option of a letter grade or pass/no pass. Also listed as ART 107 and DM 107. ADVISORY: CSIS 1 or CSIS 2/2L or equivalent computer experience

40393 Lec LI128 V Fainshtein 2.8 2.0 W 0320-0550

CSIS 108 Digital Media Lab

Transferable: CSU; GAV-GE:C1

Supervised practice and individualized computer assisted learning of software applications and techniques commonly found in the design and production of digital media (e.g., digital art and imaging, digital photography, digital print, digital audio/video, web design/authoring, DVD/CD ROMs, animation). Supplements lecture courses. Open entry/exit, so may be added at anytime during the semester. This is a pass/no pass course. May be repeated three times for credit. Also listed as ART 108 and DM 108. ADVISORY: CSIS 1 or CSIS 2/2L or equivalent computer experience.

40833 Lab LI128 R Beede 1.0 Note: See instructor

CSIS 110 Interactive Animation: Flash

Transferable: CSU; GAV-GE:C1

The production of vector graphics, animation, and interactive multimedia in Shockwave-Flash format for web pages and other digital media. Design of highly interactive web site interfaces and animated games using Flash actions (scripting). Useful for web designers/developers, animators, and multimedia authors. This course has the option of a letter grade or pass/no pass. Also listed as ART 110 and DM 110. May be repeated three times for credit. ADVISORY: CSIS 1, CSIS 2/2L, CSIS 124 or basic computer knowledge.

40410 L/L LI128 R Beede 3.2 3.0 MW 1120-1240

CSIS 112 Keyboard Speed Building

Transferable: CSU

This self-paced course is designed for students who know the alphabetic keyboard by touch and who want to develop their keyboarding speed. Students will use a microcomputer to keyboard a series of straight-copy timings, which will enable them to achieve a high level of skill. This is a pass/no pass course. May be repeated once for a total of 1 unit. ADVISORY: CSIS 122 or knowledge of keyboard with keyboarding speed of at least 25 wpm.

40852 Lab BU110 S Gaffney .5

This is an open-entry self-paced class. Please see instructor for specific instructions.

CSIS 113 Introduction to Digital Video

Transferable: CSU; GAV-GE:C1

Introduction to the aesthetic and technical aspects of digital video recording, non-linear editing, special effect generation, and production of video (and associated audio) using the personal computer equipped with specialized software such as iMovie, Final Cut Pro, and After Effects. Also considered will be the preparation of digital video for use in interactive media such as CD, DVD, and the World Wide Web. Students will produce a final digital video project on DVD. This course has the option of a letter grade or pass/no pass. May be repeated 2 times for credit. Also listed as ART 113 and DM 113. ADVISORY: CSIS 1 or CSIS 2/2L or equivalent computer experience.

40476 L/L LI128 R Beede 3.2 3.0 MW 0945-1105

CRN Type Room Instructor Hrs. Units Days Begin-End

CRN Type Room Instructor Hrs. Units Days Begin-End

 **ONLINE CLASSES:** Start by going to <http://www.gavilan.edu/disted>

You must have an email account to take an online course. Unless you have made prior arrangements with the instructor, you MUST log on by 11:59 pm on the first day of the course. Late adds must login within 24 hours of adding this course. If you miss the deadline you may be dropped. For help, contact your instructor or email disted@gavilan.edu.

CSIS 117 Visual Effects-Motion Graphics

Transferable: CSU, UC

Study of the design of visual effects and motion graphics used in digital video, film, web, multimedia, and interactive games. Includes video/graphics compositing techniques, 2D animation, basic 3D animation, and effects commonly done in digital post-production. Software such as Adobe After Effects and Apple's Motion and Shake will be used. May be repeated 3 times for credit. This course has the option of a letter grade or pass/no pass. This course is also listed as ART 117 and DM 117. ADVISORY: DM/ART/CSIS 113 or DM/ART/CSIS 140 or DM/ART/CSIS 77 or THEA 17A or basic knowledge of digital video/film editing.

40483 L/L LI128 R Beede 3.2 3.0 TR 1120-1240

CSIS 120 Computerized Accounting - QuickBooks

Transferable: CSU

An introduction to computer assisted accounting. Hands-on use of a microcomputer menu-driven accounting package to do general ledger, sales journal, cash receipts journal, cash payments journal, purchases journal, payroll, receivables, payables and related financial reports. This course has the option of a letter grade or pass/no pass. Repeatable whenever a new software package is adopted. This course is also listed as ACCT 120. ADVISORY: CSIS 1 or CSIS 2 or the equivalent computer experience. ACCT 20 or ACCT 101 or ACCT 103 or ACCT 105 or the equivalent accounting experience.

40216 L/L BU111 R Brown 3.0 2.0 T 0300-0550
ROP course

CSIS 121 Spreadsheet - MS Excel

Transferable: CSU

Introduction to the computer spreadsheet software. A hands-on approach to learning terms, commands, and applications of a spreadsheet program. This course will help prepare students for taking the Excel MOUS (Microsoft Office User Specialist) exams. This course has the option of a letter grade or pass/no pass. May be repeated once for credit when the software changes. Also listed as ACCT 121. ADVISORY: CSIS 1 or CSIS 2 or equivalent computer experience.

40241 Lec HOL3 M Bryson 4.6 2.0 MW 1120-0125
03/21/11 - 05/18/11 Above class meets at the Hollister Briggs site.

40248 Lec HOL3 F Mendez 3.3 2.0 W 0600-0905
03/09/11 - 05/25/11 Above class meets at the Hollister Briggs site. ROP course.

CSIS 122 Computer Keyboarding

Transferable: CSU

A self-paced course for students who wish to master the alphabetic and numeric keyboard on the computer. This course is designed for students who do not know the alphabetic keyboard by "touch" and for those who want to improve their ability to type straight copy with increased speed and accuracy. The course provides "hands-on" instruction to help students reach optimum computer keyboarding skills within a limited time. This is a pass/no pass course. Course may be repeated until 3 units are accrued.

40861 Lab BU110 E Venable 1.6 .5 TBA
This is a self-paced, open entry class. Please see instructor for specific instructions.

40862 Lab BU110 E Venable 1.6 1.0 TBA
This is a self-paced, open entry class. Please see instructor for specific instructions.

40591 Lab HOL3 M Bryson 3.2 .5 MW 0945-1105
02/02/11 - 05/18/11 Above class meets at the Hollister Briggs site.

40592 Lab HOL3 M Bryson 3.2 1.0 MW 0945-1240
Above class meets at the Hollister Briggs site.

40593 Lab HOL3 M Bryson 3.2 .5 MW 1120-1240
Above class meets at the Hollister Briggs site.

40811 Lab HOL3 M Bryson 3.2 1.0 MW 1120-0125
02/02/11 - 05/18/11 Above class meets at the Hollister Briggs site.

40589 Lab BU110 S Gaffney 1.6 .5 T 0600-0720

40597 Lab HOL3 D Hampton 1.6 .5 T 0600-0720
Above class meets at the Hollister Briggs site.

40590 Lab BU110 S Gaffney 3.3 1.0 T 0600-0905

40596 Lab HOL3 D Hampton 3.3 1.0 T 0600-0905
Above class meets at the Hollister Briggs site.

CSIS 124 Windows Fundamentals

Transferable: CSU

This course provides fundamental information on the Windows environment for the computer. Introductory Windows operations and file management are covered. This is a pass/no pass course. This course may be repeated three times for credit. ADVISORY: Basic keyboarding skill.

40789 Lec BU111 E Milar 1.6 1.0 T 1250-0210
02/22/11 - 05/03/11

CSIS 126 Word Processing - MS Word

Transferable: CSU

This introductory course for word processing with Windows is designed for business and non-business majors. Students will develop word processing skills to create a document, select and edit text, move and copy text, use the spelling, grammar, and thesaurus features, format text, and create headers and footnotes for a research paper. This course has the option of a letter grade or pass/no pass and may be repeated for credit when the software changes. ADVISORY: Eligible for English 260 and basic keyboarding skills.

40598 Lec MHG5 F Mendez 3.9 2.0 F 0900-1235
02/04/11 - 04/22/11 Above class meets at Morgan Hill Community site. ROP course.

40791 Lec HOL3 M Bryson 4.6 2.0 MW 0900-1105
03/21/11 - 05/18/11 Above class meets at the Hollister Briggs site.

40790 Lec BU111 E Milar 1.6 2.0 M 1250-0210

40792 Lec HOL3 F Mendez 3.9 2.0 M 0600-0935
02/07/11 - 04/18/11 Above class meets at the Hollister Briggs site. ROP course.

CSIS 128 Database - MS Access

Transferable: CSU

Introduction to Microsoft Access, a relational database management software tool. Students will learn to create and manage a database. This course will help prepare students for taking the Access MOUS (Microsoft Office User Specialist) exams. May be repeated three times for credit. This course has the option of a letter grade or pass/no pass. ADVISORY: CSIS 1 or CSIS 2 or equivalent knowledge.

40599 Lec BU111 J Conrey 3.0 2.0 W 1120-0210
03/02/11 - 05/18/11

CSIS 129 Presentation Graphics - MS PowerPoint

Transferable: CSU

This introductory course in presentation graphics will use Microsoft Office's "PowerPoint" software to create a computerized presentation (slide show) with text and objects. This course is also listed as CMUN 129. This course has the option of a letter grade or pass/no pass. May be repeated three times for credit. ADVISORY: CSIS 126 or word processing skills in the Windows environment.

40600 Lec BU110 E Venable 1.0
03/28/11 - 05/20/11 This is a self-paced, open entry class. Please see instructor for specific instructions.

40601 Lec HOL3 M Bryson 4.6 1.0 MW 0900-1105
02/23/11 - 03/16/11 Above class meets at the Hollister Briggs site.

40602 Lec HOL3 F Mendez 3.9 1.0 W 0600-0945
02/02/11 - 03/02/11 Above class meets at the Hollister Briggs site. ROP course.

CSIS 132 Intermediate Word Processing - MS Word

Transferable: CSU

This course covers formatting with macros and styles, mail merge techniques, sorting data in tables, preparing and protecting forms. These techniques will be applied to a variety of different documents: contracts, reports, surveys, manuscripts, and various types of letters. Other topics include working with shared documents in a workgroup, integrating applications and creating hyperlinks for workgroup settings using Microsoft Word. This course has the option of a letter grade or pass/no pass. May be repeated three times for credit. ADVISORY: CSIS 126 Word Processing - MS Word

 40603 Online J Conrey 2.0 See information above about online classes.

CRN Type Room Instructor Hrs. Units Days Begin-End

CSIS 134 Intermediate Excel

Transferable: CSU

This course continues on where CSIS 121 Spreadsheet - MS Excel left off. Intermediate level training in spreadsheets using the Microsoft Excel program. The course includes graphing, formatting, database features, macros, and financial business calculations for decision making. This course has the option of a letter grade or pass/no pass. May be repeated once for credit. ADVISORY: CSIS 121 Spreadsheets - MS Excel

40604 Lec BU111 J Conrey 3.0 2.0 R 1120-0210
02/10/11 - 05/19/11

CSIS 140 Basic Digital Film/Video Production

Transferable: CSU, UC; GAV-GE:C1

An on-line self-paced course covering the basics of film/video production and post production (editing) using "easy to use" computer software such as Apple's iMovie. Beneficial for students who are producing a video/film project as a requirement for another college course, extra skills development, or for self interest. Completion of the associated class or personal project in DVD format using either personal video equipment or the equipment in the Digital Media Studio is required. May be repeated twice for credit. This course has the option of a letter grade or pass/no pass. This course is also listed as ART 140 and DM 140.

 40605 Online R Beede 1.0 See info on page 48 about online classes.

CSIS 179 Introduction to Information Security

Transferable: CSU

This course introduces students to network security concepts and prepares them for computer systems and network management duties. This course covers security concepts, communications and infrastructure security, basic cryptography, and operational and organizational security. May be repeated twice for credit. This course has the option of a letter grade or pass/no pass. ADVISORY: CSIS 178.

40400 L/L BU118 V Robinson 4.0 4.0 W 0600-0950
ARR BU118 V Robinson W 0400-0555

CSIS 181 PC Hardware

Transferable: CSU

This course examines computing hardware, operating systems, and software applications from a technical side to enable students to select, install, maintain and optimize a computer system. This course will help prepare students to pursue the A+ Hardware Certification. This course has the option of a letter grade or pass/no pass. ADVISORY: CSIS 124, CSIS 1 OR CSIS 2, or equivalent computer experience.

40401 L/L BU118 V Robinson 4.0 4.0 T 0600-0950
ARR BU118 V Robinson T 0400-0555

CSIS 182 Operating Systems

Transferable: CSU

This course will survey current computer operating systems such as Microsoft Windows 98, NT, 2000 and XP. Linux will also be covered. Topics include file system management, systems requirements, network systems integration, security, and regular maintenance procedures. This course has the option of a letter grade or pass/no pass. ADVISORY: CSIS 1 or CSIS 2 or equivalent computer experience

40402 L/L BU118 V Robinson 4.0 4.0 R 0100-0500

CSIS 190 Occupational Work Experience/Computer Science

Transferable: CSU

Occupational work experience for students who have a job related to their major. A training plan is developed cooperatively between the employer, college and student. (P/NP grading) 75 hours per semester paid work = 1 unit. 60 hours non-paid (volunteer) work per semester = 1 unit. May be taken for a maximum total of 16 units. Minimum 2.00 GPA. REQUIRED: Declared vocational major.

Mandatory course orientation for the following classes will be conducted February 11: 2-3 pm, March 1: 4:30-5:30 pm, April 12: 12 pm. Meetings will be held in the Student Center-North/South Lounge. Students must attend one of the three meetings. www.gavilan.edu/cwe for assignments and details. Please contact Susan Sweeney, CWE Coordinator at ssweeney@gavilan.edu for more information.

40772 Wrk Ex LI101A S Sweeney 1.0
40773 Wrk Ex LI101A S Sweeney 2.0
40775 Wrk Ex LI101A S Sweeney 3.0
40776 Wrk Ex LI101A S Sweeney 4.0

Looking for a Job?

Gavilan College has a new Career Center Web Interface

Career Connections

Free for Gavilan College students and community.
New listings every week.



<http://www.gavilan.edu/transferctr>

CRN Type Room Instructor Hrs. Units Days Begin-End

CSIS 570 Computer Access Evaluation

Transferable: No

This course is intended to provide an in-depth computer access evaluation in order to determine an appropriate access environment for a student with a disability or multiple disabilities. This is a pass/no pass course. May be repeated as necessary based on measurable progress as documented in the Student Educational Contract. This is an open entry, open exit course. ADVISORY: This course is intended for students with a verified disability who show a need for the use of assistive computer programs and/or equipment or demonstrated academic deficit.

40416 Lab LI105 J Maringer-Cantu .5
Make an appointment with the HTC instructor (LI105). Open Entry/Open Exit

CSIS 571 Computer Assisted Instruction

Transferable: No

This course is an Assistive Computer Technology Lab designed for students who are eligible for Disability Services. The course is designed to improve basic academic skills and/or cognitive processes through the use of appropriate software or to learn assistive devices designed to make computers accessible. Course content is based on Student Educational Contracts which are developed for each student. This is a pass/no pass course. May be repeated as necessary based on measurable progress as documented in the Student Educational Contract. This is an open entry, open exit course. ADVISORY: This course is intended for students with a verified disability who show a need for the use of adaptive computer programs and/or equipment or demonstrated academic deficit.

40418 Lab LI105 J Maringer-Cantu .5
Open Entry/Open Exit
40419 Lab LI105 J Maringer-Cantu 1.0
Open Entry/Open Exit
40420 Lab LI105 J Maringer-Cantu 2.0
Open Entry/Open Exit

 40417 Online J Maringer-Cantu .5 Start by going to <http://www.gavilan.edu/disted>
You must have an email account to take this course. For help, contact your instructor or email disted@gavilan.edu. Open Entry/Open Exit.

CSIS 572 Adaptive Computer Basics

Transferable: No

This course will include an introduction to the basic concept of how computers work, using the computer keyboard, word processing, beginning Internet and presentation graphics. This course will be self-paced and adjusted so that students with disabilities can learn a number of adaptive devices designed to make computers accessible. This is a pass/no pass course. May be repeated as necessary based on measurable progress as documented in the Student Educational Contract. ADVISORY: This course is intended for students with a verified disability who show a need for the use of adaptive computer programs and/or equipment or demonstrated academic deficit.

40421 Lab LI105 J Maringer-Cantu 3.2 1.0 MW 1250-0210

Computerized Accounting: see ACCT 120
Corrections: see Administration of Justice

CRN Type Room Instructor Hrs. Units Days Begin-End

 **ONLINE CLASSES:** Start by going to <http://www.gavilan.edu/disted>. You must have an email account to take an online course. Unless you have made prior arrangements with the instructor, you **MUST** log on by 11:59 pm on the first day of class. Late adds must login within 24 hours of adding this course. If you miss the deadline you may be dropped. For help, contact your instructor or email disted@gavilan.edu.

COSMETOLOGY

COS 200 Beginning Cosmetology

Transferable: No
Fundamental principles of the science/art of beauty culture including hair design, chemical services and cosmetic therapy. May be repeated once for credit. **ADVISORY:** Eligible for English 250, 260 and Mathematics 205.

40005	L/L	COS102	G Ramirez	24.0		TWRF	0935-0330
	L/L	BU103	G Ramirez	6.4	12.0	TWRF	0810-0930

Students must purchase a cosmetology kit, manikin, and uniform (approx. \$800). This does not include books and classroom materials.

COS 201 Intermediate Cosmetology

Transferable: No
Extended studies and techniques in tinting, bleaching, permanent waving, soft perming, chemical straightening, pedicuring, waxing, and shaping and styling. **ADVISORY:** Satisfactory completion of Cosmetology 200. Eligible for English 250, 260 and Mathematics 205.

40059	L/L	COS102	R Hernandez	30.4	12.0	TWRF	0810-0330
-------	-----	--------	-------------	------	------	------	-----------

Students must purchase supplies for this class (approx. \$200). This does not include books and classroom materials.

COS 202 Advanced Cosmetology

Transferable: No
Advanced techniques in tinting, lightening, hair design and cosmetic chemistry. May be repeated once for credit. **PREREQUISITE:** Completion of COS 200 & 201. **ADVISORY:** Eligible for English 250, 260 and Mathematics 205.

40060	L/L	COS102	M Andre	14.0	12.0	TW	0830-0330
	L/L	COS102	N Khanna	14.0		RF	0830-0330

Students must purchase supplies for this class (approx. \$200). This does not include books and classroom materials.

COS 203 Practicum

Transferable: No
Advanced techniques in tinting, lightening, hair and design and cosmetic chemistry. May be repeated once for credit. **PREREQUISITE:** Completion of COS 200, 201 and 202. **ADVISORY:** Eligible for English 250, 260 and Mathematics 205.

40588	Lab	COS102	M Andre/N Khanna	28.0	.5	TWRF	0830-0330
40836	Lab	COS102	M Andre/N Khanna	28.0	1.0	TWRF	0830-0330
40837	Lab	COS102	M Andre/N Khanna	28.0	2.0	TWRF	0830-0330
40838	Lab	COS102	M Andre/N Khanna	28.0	3.0	TWRF	0830-0330
40839	Lab	COS102	M Andre/N Khanna	28.0	4.0	TWRF	0830-0330
40840	Lab	COS102	M Andre/N Khanna	28.0	5.0	TWRF	0830-0330
40869	Lab	COS102	M Andre/N Khanna	28.0	6.0	TWRF	0830-0330
40870	Lab	COS102	M Andre/N Khanna	28.0	7.0	TWRF	0830-0330
40871	Lab	COS102	M Andre/N Khanna	28.0	8.0	TWRF	0830-0330
40872	Lab	COS102	M Andre/N Khanna	28.0	9.0	TWRF	0830-0330
40873	Lab	COS102	M Andre/N Khanna	28.0	10.0	TWRF	0830-0330
40874	Lab	COS102	M Andre/N Khanna	28.0	11.0	TWRF	0830-0330
40875	Lab	COS102	M Andre/N Khanna	28.0	12.0	TWRF	0830-0330

CRN Type Room Instructor Hrs. Units Days Begin-End

COS 205 State Board Review

Transferable: No
State Board exam procedures and standards. **ADVISORY:** Cosmetology 201.
40587 Lab COS102 R Hernandez 5.9 2.0 M 0810-0145

COS 290 Occupational Work Experience/Cosmetology

Transferable: No
Occupational work experience for students who have a job related to their major. A training plan is developed cooperatively between the employer, college and student. (P/NP grading) 75 hours per semester paid work = 1 unit. 60 hours non-paid (volunteer) work per semester = 1 unit. May be taken for a maximum total of 16 units. Minimum 2.00 GPA. **REQUIRED:** Declared vocational major.

Mandatory course orientation for the following classes will be conducted February 11: 2-3 pm, March 1: 4:30-5:30 pm, April 12: 12 pm. Meetings will be held in the Student Center-North/South Lounge. Students must attend one of the three meetings. www.gavilan.edu/cwe for assignments and details. Please contact Susan Sweeney, CWE Coordinator at ssweeney@gavilan.edu for more information.



40803	Wrk Ex	LI101A	S Sweeney				1.0
40804	Wrk Ex	LI101A	S Sweeney				2.0
40805	Wrk Ex	LI101A	S Sweeney				3.0
40806	Wrk Ex	LI101A	S Sweeney				4.0

CPR: see Allied Health
Desktop Publishing: see CSIS or DM

DIGITAL MEDIA

DM 6 Web Page Authoring I

Transferable: CSU; GAV-GE:E2
An introduction to using Hypertext Mark-Up Language (HTML) and Extensible HTML (XHTML) to create web pages which can be uploaded and displayed on the World Wide Web. Students will use HTML/XHTML to create web pages with text in various sizes and colors, links to other sites, background color or patterns, graphics, tables and mailto links. Principles of design and color as they apply to screen presentations will be included. This course has the option of a letter grade or pass/no pass. May be repeated three times for credit. Also listed as CSIS 6 and LIB 6. **ADVISORY:** CSIS 1 or CSIS 2 or CSIS 3/LIB 3 advised.

	40828	Online	J Howell	2.0			See information above about online classes.
							02/07/11 - 03/25/11
	40830	Online	J Howell	2.0			See information above about online classes.
							03/28/11 - 05/27/11

DM 74 Advanced PhotoShop

Transferable: CSU; GAV-GE:C1
This course is for the PhotoShop-experienced student and explores PhotoShop's advanced features in depth. Students work on projects, which challenge their creativity and technical ability, and will be encouraged to develop complex projects for the web and for the printed page. May be repeated three times for credit. This course has the option of a letter grade or pass/no pass. This course is also listed as ART 74 and CSIS 74. **ADVISORY:** CSIS 75 PhotoShop I

40778	Lec	MHG5	R Grzan	3.3	3.0	R	0600-0905
-------	-----	------	---------	-----	-----	---	-----------

Above class meets at Morgan Hill Community site.

DM 75 Photoshop I - Adobe PhotoShop

Transferable: CSU; GAV-GE:C1
This course is based on the software application Adobe Photoshop. Students learn to scan photographs and manipulate them using Photoshop tool box and special effects filters. They will learn to correct photos; mask image using channels; create duotone, tritone, and quadtone images; prepare photos for use in printing and on the web. This course has the option of a letter grade or pass/no pass. May be repeated three times for credit. Students who repeat this course will learn new and advanced features. This course is also listed as CSIS 75. **ADVISORY:** CSIS 124 (Windows Fundamentals), CSIS 2L

40780	L/L	LI128	K Powers	3.3	3.0	M	0320-0625
40782	L/L	MHG5	R Grzan	3.3	3.0	T	0600-0905

Above class meets at Morgan Hill Community site.

Please help protect Gavilan's park-like setting by properly disposing of litter and recycling.

CRN Type Room Instructor Hrs. Units Days Begin-End

DM 76 Digital Illustration

Transferable: CSU; GAV-GE:C1

Illustration techniques using computer Bezier curve-based illustration software tools to do diagrams and graphics for use in art, desktop publishing, web graphics, multimedia, and computer presentations. This basic Illustrator course is focused on the technical and historical aspects of digital design and illustration as well as the development of personal artistic expression and visual perception through the use of the digital illustration medium. The course will include lectures and discussions about color, composition and content, computer and illustration program use, printing and presentation techniques. This course has the option of a letter grade or pass/no pass. This course is also listed as ART 76 and CSIS 76. ADVISORY: CSIS 1 or CSIS 2 or equivalent computer experience.

40784 L/L LI128 V Fainshtein 3.3 3.0 W 0600-0905

DM 77 Introduction to Digital Media and its Tools

Transferable: CSU, UC; GAV-GE:C1

An introduction to the field of digital media, including history, social impact, concepts, career options and industry trends. Applying learned visual and aural design principles, students will explore the use of computer-based tools in the design and production of digital media by creating and editing digital images, sounds, video, animation, and text. A comprehensive term project for publication on the web or CD ROM will be required. This course is also listed as ART 77 and CSIS 77. This course has the option of a letter grade or pass/no pass. May be repeated twice for credit. ADVISORY: CSIS 124, CSIS 1, CSIS 2/2L, CSIS 3, or familiarity using the Macintosh or Windows operating system.

40786 L/L LI128 R Beede 3.2 3.0 TR 0945-1105

DM 80 Digital Photography

Transferable: CSU, UC; GAV-GE:C1

The study of digital photography from digital camera to the computer-based printer or digital media. Artistic, theoretical, and technical aspects will be considered. Topics include information about types and purchasing of digital cameras; theory, mechanics, and art of digital imagery; digital darkroom; eccentricities of digital photo taking; stitching photos for virtual reality; and preparing digital images for print, World Wide Web and other digital media. This course has the option of a letter grade or pass/no pass. This course is also listed as ART 80 and CSIS 80. ADVISORY: CSIS 1 or CSIS 2/2L or ART 8A or equivalent computer experience.

40787 L/L LI128 J Edberg 5.4 3.0 MW 1250-0315

DM 85 Web Design I: Dreamweaver

Transferable: CSU; GAV-GE:C1

Basic and intermediate principles of designing Web pages/sites using the Dreamweaver web design software and HTML. Emphasis will be on good design and the use of tables, frames, forms, rollovers, DHTML, XHTML, behaviors, and CSS. Also includes site maintenance and the integration of multimedia components such as graphics, sound, animation, and video. This course is for the content person to design, develop, and maintain effective Web sites. This course is also listed as ART 85 and CSIS 85. This course has the option of a letter grade or pass/no pass. May be repeated twice for credit. ADVISORY: CSIS 6 or basic knowledge of HTML.

 40834 Online S Lawrence 2.0 See info on page 50 about online classes. 02/02/11 - 03/28/11

DM 107 Digital Media Design

Transferable: CSU

Fundamentals of design for visual, time-based, interactive, and sound arts as applied to digital media. Includes basic storytelling, graphic design, information architecture, and human factors. Page layout, scripting, storyboards, and flow charts will be used as tools applicable to the design and development of business presentations, interactive media, educational multimedia, animation, web sites, video games, and film/video. This course has the option of a letter grade or pass/no pass. Also listed as ART 107 and CSIS 107. ADVISORY: CSIS 1 or CSIS 2/2L or equivalent computer experience

40392 Lec LI128 V Fainshtein 2.8 2.0 W 0320-0550



You can:

- Make a web site for CyberSpace.
- Produce a video for GAVTV or YouTube.
- Record your Podcast for the Internet
- Animate your story or game idea
- Design graphics for web, TV or print
- Shoot and edit digital photographs.

CRN Type Room Instructor Hrs. Units Days Begin-End

DM 108 Digital Media Lab

Transferable: CSU; GAV-GE:C1

Supervised practice and individualized computer assisted learning or software applications and techniques commonly found in the design and production of digital media (e.g., digital art and imaging, digital photography, digital print, digital audio/video, web design design/authoring, DVD/CD ROMs, animation). Supplements lecture courses. Open entry/exit, so may be added anytime during the semester. This is a pass/no pass course. Also listed as ART 108 and CSIS 108. May be repeated three times for credit. ADVISORY: CSIS 1 or CSIS 2/2L or equivalent computer experience.

40831 Lab LI128 R Beede 1.0 Note: See instructor

DM 110 Interactive Animation: Flash

Transferable: CSU; GAV-GE:C1

The production of vector graphics, animation, and interactive multimedia in Shockwave-Flash format for web pages and other digital media. Design of highly interactive web site interfaces and animated games using Flash actions (scripting). Useful for web designers/developers, animators, and multimedia authors. This course has the option of a letter grade or pass/no pass. Also listed as ART 110 and CSIS 110. May be repeated three times for credit. ADVISORY: CSIS 1, CSIS 2/2L, CSIS 124 or basic computer knowledge.

40474 L/L LI128 R Beede 3.2 3.0 MW 1120-1240

DM 113 Introduction to Digital Video

Transferable: CSU; GAV-GE:C1

Introduction to the aesthetic and technical aspects of digital video recording, non-linear editing, special effect generation, and production of video (and associated audio) using the personal computer equipped with specialized software such as iMovie, Final Cut Pro, and After Effects. Also considered will be the preparation of digital video for use in interactive media such as CD, DVD, and the World Wide Web. Students will produce a final digital video project on DVD. This course has the option of a letter grade or pass/no pass. May be repeated 2 times for credit. Also listed as ART 113 and CSIS 113. ADVISORY: CSIS 1 or CSIS 2/2L or equivalent computer experience

40481 L/L LI128 R Beede 3.2 3.0 MW 0945-1105

DM 117 Visual Effects-Motion Graphics

Transferable: CSU, UC

Study of the design of motion graphics and special effects used in digital video and film, web, multimedia, and interactive games. Includes video/graphics compositing techniques, 2D animation, basic 3D animation, and special effects commonly generated in digital post-production. Software such as Adobe After Effects or Apple's Motion will be used. May be repeated three times for credit. This course has the option of a letter grade or pass/no pass. This course is also listed as ART 117 and CSIS 117. ADVISORY: DM/ART/CSIS 113 or DM/ART/CSIS 140 or DM/ART/CSIS 77 or THEA 17A or basic knowledge of digital video/film editing.

40484 L/L LI128 R Beede 3.2 3.0 TR 1120-1240

Campus under construction

ROOM NUMBERS MAY CHANGE! Check room numbers online before your first class.

CRN Type Room Instructor Hrs. Units Days Begin-End

CRN Type Room Instructor Hrs. Units Days Begin-End

 **ONLINE CLASSES:** Start by going to <http://www.gavilan.edu/disted>
 You must have an email account to take an online course. Unless you have made prior arrangements with the instructor, you MUST log on by 11:59 pm on the first day of the course. Late adds must login within 24 hours of adding this course. If you miss the deadline you may be dropped. For help, contact your instructor or email disted@gavilan.edu.

DM 140 Basic Digital Film/Video Production

Transferable: CSU, UC; GAV-GE:C1

An on-line self-paced course covering the basics of film/video production and post production (editing) using "easy to use" computer software such as Apple's iMovie. Beneficial for students who are producing a video/film project as a requirement for another college course, extra skills development, or for self interest. Completion of the associated class or personal project in DVD format using either personal video equipment or the equipment in the Digital Media Studio is required. May be repeated twice for credit. This course has the option of a letter grade or pass/no pass. This course is also listed as ART 140 and CSIS 140.

 40826 Online R Beede 1.0 See information above about online classes.

**Drama: See Mass Communications & Television, Theatre Arts
 Early Childhood Education: See Child Development**

ECOLOGY

ECOL 1 Conservation of Natural Resources

Transferable: CSU, UC; CSU-GE:B2, B3, IGETC:5B; GAV-GE:B2, B3

This course examines the fundamentals of ecology (the study of the relationships between organisms and their environment) with special emphasis on human effects on the environment. Topics of discussion will include ecosystem dynamics, resources, pollution, population growth, and the clash between economic and political policy and the environment. ADVISORY: Eligible for English 250 and English 260.

40463	L/L	PS105	R Morales	3.3	4.0	F	1120-0225
	L/L	LS102	R Morales	3.3		S	0900-1205
This service learning course section involves community work. See page 19 for more information.							
40461	Lec	LS101	J Hubbard	3.2	4.0	TR	1250-0210
	Lab	LS102	J Hubbard	3.3		T	0230-0535
40462	Lec	LS101	J Hubbard	3.2	4.0	TR	1250-0210
	Lab	LS102	J Hubbard	3.3		R	0230-0535

ECONOMICS

ECON 1 Principles of Macroeconomics

Transferable: CSU, UC; CSU-GE:D2, IGETC:4B; GAV-GE:D2; CAN:ECON2

Introduction to the principles of macroeconomics, social organization of the economy; supply and demand; the determinants of national income and production, economic growth, the global economy and trade, employment, prices, savings and investment; the nature and effectiveness of monetary and fiscal policy. This course has the option of a letter grade or pass/no pass. ADVISORY: Eligible for English 1A and Mathematics 233.

40383	Lec	HOL2	D Carlisle	3.0	3.0	F	1120-0210
Above class meets at the Hollister Briggs site.							
40326	Lec	BU120	B Truongson	3.2	3.0	TR	1250-0210
40863	Lec	MHG 5	B Truongson	3.0	3.0	M	0600-0905
Above class meets at the Morgan Hill Community Center site.							
	40327	Online	D Carlisle	3.0	See information above about online classes.		

ECON 2 Principles of Microeconomics

Transferable: CSU, UC; CSU-GE:D2, IGETC:4B; GAV-GE:D2; CAN:ECON4

Introduction to microeconomic principles and theory; supply, demand; product and factor price determination, resource allocation, costs, revenues, and profits under different competitive situations; international trade; government regulation and taxation. Note: Economics 1 is not a prerequisite for Economics 2. This course has the option of a letter grade or pass/no pass. ADVISORY: Eligible for English 260, English 250 and Mathematics 233.

40384	Lec	MHG5	B Truongson	3.2	3.0	TR	0945-1105
Above class meets at Morgan Hill Community site.							
40385	Lec	PB13	A Shokou	3.3	3.0	T	0600-0905

Education: see Child Development, Liberal Arts, Liberal Arts with Elementary Education Emphasis

ENGLISH

ENGL 1A Composition



Transferable: CSU, UC; CSU-GE:A2, IGETC:1A; GAV-GE:A2; CAN:ENGL2, ENGL SEQ A

This is a writing course which emphasizes expository writing, argumentative writing, and critical reading of expository prose. It is meant to train students in clear thinking and reasoned support of ideas. Students will be given the opportunity to read models of good expository and argumentative prose and learn the techniques of good writing. These include choosing appropriate subjects, developing restricted, unified, and precise theses and presenting supporting evidence in a logical, lucid, and effective manner. To achieve this end, students write no fewer than six essays and read at least five works, two of which are book length. PREREQUISITE: English 250 and English 260 or English 250 and SSCI 270A or English 250 and SSCI 270B with a grade of 'C' or better or satisfactory score on the English placement examination.

1 Your ENGL 1A class has a theme.
2
3 See list on page 53.

2	40032	Lec	HU102	T Mack	3.2	3.0	MW	0810-0930
	40033	Lec	HU102	D Condon	3.2	3.0	TR	0810-0930
	40034	Lec	MHG12	M Bragger	3.2	3.0	MW	0810-0930
Above class meets at Morgan Hill Community site.								
	40035	Lec	HOL5	G Mora	3.3	3.0	F	0900-1205
Above class meets at the Hollister Briggs site.								
	40064	Lec	MHG3	M Bragger	3.3	3.0	F	0900-1205
Above class meets at Morgan Hill Community site.								
11	40038	Lec	HU103	J Roscher	3.2	3.0	TR	0945-1105
3	40036	Lec	HOL5	C Salvin	3.2	3.0	TR	1120-1240
Above class meets at the Hollister Briggs site.								
3	40039	Lec	HU102	C Salvin	3.2	3.0	MW	1120-1240
11	40042	Lec	PB14	J Roscher	3.2	3.0	TR	1250-0210
	40043	Lec	HU102	J Gatewood	3.2	3.0	MW	1250-0210
	40044	Lec	HU102	Staff	3.2	3.0	MW	0230-0350
5	40045	Lec	HU103	S Schessler	3.2	3.0	TR	0400-0520
6	40058	Lec	PB4	T Brett	3.3	3.0	R	0600-0905
	40061	Lec	HOL1	S Sloan	3.3	3.0	W	0600-0905
Above class meets at the Hollister Briggs site.								
	40062	Lec	HU102	Staff	3.3	3.0	M	0600-0905
2	40063	Lec	MHG3	T Mack	3.3	3.0	T	0600-0905
Above class meets at Morgan Hill Community site.								

ONLINE:

	1	40031	Online	D Luoma	3.0	See information above about online classes.		
		40037	Online	E Crook	3.0	See information above about online classes.		

PUENTE PROGRAM:

4 40041 Lec HU103 S Sandler 3.2 3.0 TR 1120-1240
 Students enrolled in this class will participate in the PUENTE Program and will need to complete 10 hours of mentoring. Required: Complete an application with the PUENTE counselor prior to registration. This class is part of a learning community. Students must also enroll in GUID 1, CRN 40170. See ad on page 55.

Have you met the prerequisite? **It's required!**

CRN Type Room Instructor Hrs. Units Days Begin-End

ENGL 1B Composition and Literature

Transferable: CSU, UC; CSU-GE:C, IGETC:3B; GAV-GE:C2; CAN:ENGL4, ENGL SEQ A

English 1B continues the work begun in 1A, but now the emphasis shifts to writing expository prose in conjunction with reading and analyzing imaginative literature. Students are to write as fledgling critics and use the text as a basis for other forms of reflection. The reading requirement includes short stories, poetry, drama, and at least two novels. Course work will also include fundamentals of research writing. **PREREQUISITE:** English 1A with a grade of "C" or better.

	40068	Lec	HU103	S Hirasuna	3.3	3.0	F	0900-1205
	40067	Lec	HU102	G Richards	3.2	3.0	TR	0945-1105
	40069	Lec	HU103	E Crook	3.2	3.0	MW	1120-1240
	40072	Lec	MA102	S Knapp	3.2	3.0	MW	1250-0210
14	40071	Lec	HU103	S Schessler	3.2	3.0	TR	1250-0210
14	40073	Lec	HU103	S Schessler	3.2	3.0	TR	0230-0350
	40066	Lec	MHG13	Staff	3.2	3.0	MW	0400-0520
	Above class meets at Morgan Hill Community site.							
7	40074	Lec	PB4	T Brett	3.3	3.0	W	0600-0905

ONLINE:

	40065	Online	J Hooper	3.0	See info on page 52 about online classes.			
	40070	Online	K Warren	3.0	See info on page 52 about online classes.			

ENGL 1C Critical Reasoning and Writing

Transferable: CSU, UC; CSU-GE:A3, IGETC:1B; GAV-GE:C2

This course is designed to develop critical thinking, reading, and writing skills beyond the level achieved in English 1A. The emphasis is on critical analysis of arguments and the development of the ability to integrate the principles of critical thinking into essay writing. **PREREQUISITE:** English 1A with a grade of "C" or better.

	40095	Lec	HU103	G Mora	3.2	3.0	MW	0810-0930
	40097	Lec	MA102	Condon	3.2	3.0	TR	1120-1240
	40098	Lec	HU103	M Oral	3.2	3.0	MW	0230-0350
	40099	Lec	HU102	K Smith	3.2	3.0	TR	0400-0520
	40096	Lec	HOL1	K Hull	3.2	3.0	MW	0400-0520
	Above class meets at the Hollister Briggs site.							
8	40100	Lec	PB4	T Brett	3.3	3.0	M	0600-0905

ONLINE:

	40094	Online	C Chaffin	3.0	See info on page 52 about online classes.			
--	-------	--------	-----------	-----	---	--	--	--

ENGL 2J Mythology

Transferable: CSU, UC; CSU-GE:C2, IGETC:3B; GAV-GE:C2

This course is a survey of myths from around the world, with an emphasis on literary analysis of the myths. The course covers the purposes and types of myths; the development of myths and mythological characters, the recurring elements of mythological structures, the influence of mythology on contemporary texts. **PREREQUISITE:** Eligible for English 1A.

	40154	Lec	PB14	K Warren	3.2	3.0	TR	1120-1240
--	-------	-----	------	----------	-----	-----	----	-----------

ENGL 4B British Literature - 1798 to Present

Transferable: CSU, UC; CSU-GE:C2, IGETC:3B; GAV-GE:C2; CAN:ENGL10, ENGL SEQ B

This course is a study of the masters of British Literature from 1798 to present. In this course we will read and analyze the literature of Blake, Wordsworth, Coleridge, Byron, Shelley, Keats, Tennyson, Browning, Arnold, Clough, Hopkins, Rossetti, Bronte, Yeats, Joyce, Woolf, Lawrence, Eliot, and Forster. Note: this course need not be taken in sequence. **PREREQUISITE:** Eligible for English 1A.

	40269	Lec	PB13	S Sandler	3.2	3.0	MW	1120-1240
--	-------	-----	------	-----------	-----	-----	----	-----------

ENGL 9A Introduction to Creative Writing

Transferable: CSU, UC; CSU-GE:C2; GAV-GE:C2; CAN:ENGL6

This course includes the writing, reading, and critical discussions of various forms of poetry and fiction. **PREREQUISITE:** Eligible for English 1A.

	40270	Lec	PB4	K Smith	3.2	3.0	TR	1250-0210
--	-------	-----	-----	---------	-----	-----	----	-----------

Choose a **THEME** for your English class:

Find the number, by the course section number, that corresponds to a theme below.

- 1 Read classics of nature writing and visit the virtual woods with Thoreau.
- 2 Chicana(o) Style: Step into the world of the Mexican-American, the bi-racial, bi-cultural experience. We'll read literature that will have you laughing your socks off one moment and scratching your head the next. Learn about or relive the joys and pains of the wonderful and sometimes strange Mexican-American life!
- 3 Investigate environmental issues, particularly those connected to what we eat and where we live.
- 4 Punte: Develop writing skills through an emphasis on Chicano/Latino literature.
- 5 Consider how marginalized writers can make an impact on mainstream social thinking and develop the argumentation skills to make its voice heard.
- 6 Explore the exciting realm of science and discover who we are, how we got here, and learn about the scientists and explorers who got us here while learning to write with panache, flair, and accuracy.
- 7 Explore the great literature of the human condition, challenging you to respond to literary art, science fiction, music, tragedy, and the joy of life and living.
- 8 Learn to think courageously, to think intelligently, and to think for yourself through challenging the pseudoscientific, the paranormal, and the make-believe world of nutty beliefs and scams.
- 9 Service Learning: Explore the connections between language, identity, and community through our work with ESL (English as a Second Language) students.
- 10 Explore American consumerism and wild alternatives.
- 11 The American Dream: Revisit the land of freedom and equality.
- 12 First Year Experience: Learn to critically read, write, and think about contemporary issues; evaluate the credibility of sources ranging from academia to the media; and embrace the importance of understanding what is happening in the world around you.
- 13 First Year Experience: Explore the issues of peace and conflict through reading and writing.
- 14 American Outsiders: Explore American literature from the "outsider's" perspective, focusing on works from authors protesting the American mainstream or demanding to be let in.
- 15 Telling Our Stories: Explore how storytelling makes us stronger, and read authors such as Victor Villaseñor in *Burro Genius* whose lives can inspire us.

First Year Experience A Wise Choice

- higher GPA,
- increased involvement in school,
- more friends,
- more fun in school,
- ability to meet goals,
- stronger critical thinking, reading, and writing abilities,
- saving time and money

First Year Experience (FYE) is a program in place in many colleges across the country. This program was developed because research has shown that students who make connections with their teachers, classmates, and campus are more likely to succeed. So what is FYE? At Gavilan, this program links required English courses together and provides tutoring and counseling. How do students benefit? By working together with your classmates and instructors, you will develop a stronger network of support. Students who enroll in FYE often report

MARK YOUR CALENDARS - Thursday, January 27th from 9 am - 1 pm, Student Success Orientation. Meet your instructors! Find out where your classes are and how to get money for books! Get connected with programs on campus such as EOPS, TRIO, MESA and more. Free lunch provided. RSVP to Michelle Foguet-Mendoza at 408-848-4776 ASAP; spaces are limited.

What FYE has meant to me:

"First Year Experience has been very important to me. I was a shy person and had trouble asking for help. I was not as successful as I wanted to be. I discovered that getting help from people makes it easier to get things done without so much stress about it. Now I ask for help from my teacher, tutors, and counselors, and I visit the Writing Center often. My life has changed a lot. I'm so grateful Gavilan College has this program." *Veronica*

"I took this class last semester and learned a lot more than I did in high school. It's amazing and you will learn to like English. I hated English in high school and taking FYE has helped me in many ways, from writing a paper to being organized. You will write a lot in all of your classes and this program helps you be more successful. It does more than just refresh you." *Karissa*

"I have gained confidence in English at Gavilan. I will take with me the faster reading strategies on how to take notes or highlight the most important facts that summarize what I finished reading. Overall, the pride of reading will stick with me through the summer and I have never had much confidence in reading going into summer" *Alex*



Get a head start and get prepared BEFORE the semester begins!

Plan on attending our student success orientation.

Thursday, January 27th

9 am - 1 pm

Free lunch included!

RSVP to Michelle Foguet-Mendoza at 408-848-4776.

The following classes are part of a First Year Experience learning community. You must enroll in both courses.

ENGL 250 Practical Writing

40124	Lec	PB4	S White	3.2	3.0	MW	1250-0210
	Lab	LI171	S White	1.0		M	0230-0320

ENGL 260 Preparation for College Reading

40150	Lec	PB4	J Gatewood	3.2	3.0	MW	1120-1240
-------	-----	-----	------------	-----	-----	----	-----------

or

ENGL 250 Practical Writing

40125	Lec	PB4	S White	3.2	3.0	MW	1250-0210
	Lab	LI171	S White	1.0		W	0230-0320

ENGL 260 Preparation for College Reading

40151	Lec	PB4	J Gatewood	3.2	3.0	MW	1120-1240
-------	-----	-----	------------	-----	-----	----	-----------

ENGL 250 Practical Writing

40122	Lec	HU102	J Hooper	3.2	3.0	TR	1250-0210
	Lab	LI120	J Hooper	1.0		T	0230-0320

ENGL 260 Preparation for College Reading

40147	Lec	HU102	J Hooper	3.2	3.0	TR	1120-1240
-------	-----	-------	----------	-----	-----	----	-----------

ENGL 747 Film and Literacy *recommended*

40901	Lec	HU102	J Hooper	4.2		R	0600-0930
-------	-----	-------	----------	-----	--	---	-----------

Class meets these Thursdays, 02/17, 03/17 and 04/14.

or

ENGL 250 Practical Writing

40123	Lec	HU102	J Hooper	3.2	3.0	TR	1250-0210
	Lab	LI120	J Hooper	1.0		W	1120-1210

ENGL 260 Preparation for College Reading

40148	Lec	HU102	J Hooper	3.2	3.0	TR	1120-1240
-------	-----	-------	----------	-----	-----	----	-----------

ENGL 747 Film and Literacy *recommended*

40901	Lec	HU102	J Hooper	4.2		R	0600-0930
-------	-----	-------	----------	-----	--	---	-----------

Class meets these Thursdays, 02/17, 03/17 and 04/14.

ENGL 420 Reading Improvement

40251	Lec	PB14	K Warren	3.2	3.0	MW	1120-1240
	Lab	LI171	K Warren	1.0		M	1010-1100

ENGL 440 Basic Writing

40260	Lec	PB14	K Warren	3.2	3.0	MW	1250-0210
	Lab	LI171	K Warren	1.0		W	1010-1100

or

ENGL 420 Reading Improvement

40252	Lec	PB14	K Warren	3.2	3.0	MW	1120-1240
	Lab	LI171	K Warren	1.0		T	1120-1210

ENGL 440 Basic Writing

40261	Lec	PB14	K Warren	3.2	3.0	MW	1250-0210
	Lab	LI171	K Warren	1.0		T	1220-0110

CRN Type Room Instructor Hrs. Units Days Begin-End

ENGL 9B Advanced Creative Writing

Transferable: CSU, UC; CSU-GE:C2; GAV-GE:C2

This class is a continuation of English 9A, with the emphasis shifting to publication. The genre of non-fiction will be the primary focus, but the genres of fiction will also be taught at a more comprehensive level than in English 9A. The process of finding a market for one's work will be followed step by step. The class may compile and publish "Soaring", Gavilan's literary magazine, each spring semester. PREREQUISITE: English 9A with a grade of credit or C or better.

40271 Lec PB4 K Smith 3.2 3.0 TR 1250-0210

ENGL 9C Poetry Writing

Transferable: CSU, UC; CSU-GE:C2; GAV-GE:C2

This course includes the writing, reading, and critical discussions of various forms of poetry. PREREQUISITE: English 9A with a grade of credit or C or better.

40272 Lec PB4 K Smith 3.2 3.0 TR 1250-0210

ENGL 12B Tutoring Writers: Training/Theory & Practice

Transferable: CSU

Fundamentals of compositional theory, the writing process, peer-to-peer communication, interacting with faculty and educational institutions and effective responses to writing will be covered. In addition, students will gain an understanding of the basic history, methodology and practice of writing pedagogy while developing a writing community that aids in connecting them to their own writing practice. ADVISORY: Eligible for English 1A.

40028 Lec LI120 K Smith 1.0 1.0 M 0300-0400

ENGL 12C Tutoring Writers: Training/Theory & Practice

Transferable: CSU

Fundamentals of compositional theory, the writing process, peer-to-peer communication, interacting with faculty and educational institutions and effective responses to writing will be covered. In addition, students will gain an understanding of the basic history, methodology and practice of writing pedagogy while developing a writing community that aids in connecting them to their own writing practice. ADVISORY: Eligible for English 1A.

40029 Lec LI120 K Smith 1.0 1.0 M 0300-0400

ENGL 12D Tutoring Writers: Training, Theory & Practice

Transferable: CSU

Fundamentals of compositional theory, the writing process, peer-to-peer communication, interacting with faculty and educational institutions and effective responses to writing will be covered. In addition, students will gain an understanding of the basic history, methodology and practice of writing pedagogy while developing a writing community that aids in connecting them to their own writing practice. ADVISORY: Eligible for English 1A.

40030 Lec LI120 K Smith 1.0 1.0 M 0300-0400

ENGL 22 Field Work and Service

Transferable: CSU

Supervised field work within the college and with local agencies. Students serve in useful group activities in leadership roles prescribed for them by faculty or community agencies. A maximum of six units may be completed. This is a pass/no pass course. REQUIRED: Learning contracts must be filled out and signed by the student and the supervising instructor.

40101 Fld Ex K Warren 1.0

ENGL 23 Independent Study

Transferable: CSU

Designed to afford selected students specialized opportunities for exploring areas at the independent study level. The courses may involve extensive library work, research in the community, or special projects. May be repeated until six units of credit are accrued. This course has the option of a letter grade or pass/no pass. REQUIRED: The study outline prepared by the student and the instructor must be filed with the department and the dean.

40103 Ind LI120 K Smith 1.0

40102 Ind LI120 K Smith 2.0

40104 Ind PB11 K Warren 1.0

40105 Ind PB11 K Warren 2.0



This class can fulfill your IGETC humanities transfer requirement.

ENGL 4B

British Literature 1798 to Present

Instructor: Scott Sandler



ENGL 2J Mythology

Instructor: Karen Warren

This course offers an exploration of the major figures and themes of Greek, Aztec and African mythologies.

Transferable to UC and CSU. Satisfies the Humanities requirement under both the CSU and IGETC GE patterns.

Have you met the prerequisite?
It's required!



The Puente Project is a two-semester program that combines three components: writing, counseling and mentoring to support students to transfer to four-year universities and colleges. The Guidance 6 course focuses on self assessment and career development. The English 1A course focuses on Mexican American/Latino literature. The program also includes a student leadership conference, university visits and mentor/student socials. The program is open to all eligible students. For more information, call Celia Marquez, Puente Co-Coordinator at 408-848-4807.

Required: Complete a program application with the Puente Counselor prior to registration.

GUID 1 CRN 40170 Marquez C MW 1120A-1240P
Students will need to complete 10 hours of mentoring.

ENGL1A CRN 40041 Sandler S TuTh 1120A-1240P

CRN Type Room Instructor Hrs. Units Days Begin-End

ENGL 250 Practical Writing

Transferable: No

This course covers writing clear, correct, effective essays and learning preliminary research skills. PREREQUISITE: English 440 or ESL 563 with a grade of 'C' or better or satisfactory score on the English placement examination.

1 Your ENGL 250
2 class has a theme.
3 See list on page 53.

9	40106	Lec	PB4	S Sandler	3.2	3.0	MW	0810-0930
		Lab	LI120	S Sandler	1.0		M	0945-1035
This service learning course section involves community work. See page 19 for more information.								
9	40107	Lec	PB4	S Sandler	3.2	3.0	MW	0810-0930
		Lab	LI120	S Sandler	1.0		W	0945-1035
This service learning course section involves community work. See page 19 for more information.								
	40109	Lec	PB4	J McMillen	3.2	3.0	TR	0810-0930
		Lab	LI120	J McMillen	1.0		F	0810-0900
	40110	Lec	PB4	J McMillen	3.2	3.0	TR	0810-0930
		Lab	LI120	J McMillen	1.0		F	0910-1000
10	40113	Lec	HU102	C Salvin	3.2	3.0	MW	0945-1105
		Lab	LI120	C Salvin	1.0		M	0845-0935
10	40114	Lec	HU102	C Salvin	3.2	3.0	MW	0945-1105
		Lab	LI120	C Salvin	1.0		W	0845-0935
10	40116	Lec	HOL5	C Salvin	3.2	3.0	TR	0945-1105
		Lab	HOL3	C Salvin	1.0		T	0845-0935
Above class meets at the Hollister Briggs site.								
10	40117	Lec	HOL5	C Salvin	3.2	3.0	TR	0945-1105
		Lab	HOL3	C Salvin	1.0		R	0845-0935
Above class meets at the Hollister Briggs site.								
	40118	Lec	PB4	J McMillen	3.2	3.0	TR	0945-1105
		Lab	LI120	J McMillen	1.0		F	1010-1100
	40119	Lec	PB4	J McMillen	3.2	3.0	TR	0945-1105
		Lab	LI120	J McMillen	1.0		F	1110-1200
	40134	Lec	MHG10	S Frazier	3.2	3.0	MW	0945-1105
		Lab	MHG10	S Frazier	1.0		M	0845-0935
Above class meets at Morgan Hill Community site.								
	40135	Lec	MHG10	S Frazier	3.2	3.0	MW	0945-1105
		Lab	MHG10	S Frazier	1.0		W	0845-0935
Above class meets at Morgan Hill Community site.								
	40120	Lec	MA102	M Oral	3.2	3.0	MW	1120-1240
		Lab	LI120	M Oral	1.0		M	1250-0140
	40121	Lec	MA102	M Oral	3.2	3.0	MW	1120-1240
		Lab	LI120	M Oral	1.0		W	1250-0140
	40126	Lec	HU102	O Osikomaiya	3.2	3.0	TR	0230-0350
		Lab	LI171	O Osikomaiya	1.0		T	0400-0450
	40127	Lec	HU102	O Osikomaiya	3.2	3.0	TR	0230-0350
		Lab	LI171	O Osikomaiya	1.0		R	0400-0450
	40128	Lec	HU102	Staff	3.2	3.0	MW	0400-0520
		Lab	LI120	Staff	1.0		M	0530-0620
	40129	Lec	HU102	Staff	3.2	3.0	MW	0400-0520
		Lab	LI120	Staff	1.0		W	0530-0620
	40130	Lec	PB14	K Diehl	3.2	3.0	TR	0630-0750
		Lab	LI120	K Diehl	1.0		T	0530-0620
	40131	Lec	PB14	K Diehl	3.2	3.0	TR	0630-0750
		Lab	LI120	K Diehl	1.0		R	0530-0620

↳ continued

Don't forget

A counselor's signature is required if you take 18 or more units (spring/fall) or 6 or more units (summer).

You do not need a counselor's signature to register for a class with a prerequisite that was successfully completed at Gavilan.

CRN Type Room Instructor Hrs. Units Days Begin-End

ENGL 250 Continued

	40132	Lec	HOL5	V Parker	3.2	3.0	MW	0700-0820
		Lab	HOL5	V Parker	1.0		M	0830-0920
Above class meets at the Hollister Briggs site.								
	40133	Lec	HOL5	V Parker	3.2	3.0	MW	0700-0820
		Lab	HOL5	V Parker	1.0		W	0830-0920
Above class meets at the Hollister Briggs site.								

FIRST YEAR EXPERIENCE CLASSES ENGL 250 CLASSES (See ad on page 54):

12	40124	Lec	PB4	S White	3.2	3.0	MW	1250-0210
		Lab	LI171	S White	1.0		M	0230-0320
This class is part of a Learning Community. If you enroll you must also enroll in ENGL 260, CRN 40150.								
12	40125	Lec	PB4	S White	3.2	3.0	MW	1250-0210
		Lab	LI171	S White	1.0		W	0230-0320
This class is part of a Learning Community. If you enroll you must also enroll in ENGL 260, CRN 40151.								
13	40122	Lec	HU102	J Hooper	3.2	3.0	TR	1250-0210
		Lab	LI120	J Hooper	1.0		T	0230-0320
This class is part of a Learning Community. If you enroll you must also enroll in ENGL 260, CRN 40147.								
13	40123	Lec	HU102	J Hooper	3.2	3.0	TR	1250-0210
		Lab	LI120	J Hooper	1.0		W	1120-1210
This class is part of a Learning Community. If you enroll you must also enroll in ENGL 260, CRN 40148.								

ENGL 260 Preparation for College Reading

Transferable: No; GAV-GE:A3

This is a course presenting strategies in the technique and practice of college level critical reading and thinking skills.

PREREQUISITE: Completion of English 420 or ESL 562 with a grade of 'C' or better or Assessment recommendation.

1 Your ENGL 260
2 class has a theme.
3 See list on page 53.

	40145	Lec	HU103	K Hull	3.2	3.0	TR	0810-0930
	40149	Lec	HU102	I Tracey	3.3	3.0	F	0910-1215
	40146	Lec	PB4	K Hull	3.2	3.0	MW	0945-1105
	40152	Lec	HU103	J Hooper	3.2	3.0	MW	1250-0210
Recommended: Attend a free noncredit class: ENGL 747, Film and Literacy: Meets Thursdays: 3/10-3/24.								
	40153	Lec	HOL5	V Parker	3.2	3.0	MW	0530-0650
Above class meets at the Hollister Briggs site.								

FIRST YEAR EXPERIENCE CLASSES ENGL 260 CLASSES (See ad on page 54):

12	40150	Lec	PB4	J Gatewood	3.2	3.0	MW	1120-1240
This class is part of a Learning Community. If you enroll you must also enroll in ENGL 250, CRN 40124.								
12	40151	Lec	PB4	J Gatewood	3.2	3.0	MW	1120-1240
This class is part of a Learning Community. If you enroll you must also enroll in ENGL 250, CRN 40125.								
13	40147	Lec	HU102	J Hooper	3.2	3.0	TR	1120-1240
This class is part of a Learning Community. If you enroll you must also enroll in ENGL 250, CRN 40122.								
13	40148	Lec	HU102	J Hooper	3.2	3.0	TR	1120-1240
This class is part of a Learning Community. If you enroll you must also enroll in ENGL 250, CRN 40123.								

ENGL 420 Reading Improvement

Transferable: No

This is a practical, "how to" course teaching various methods of learning and reading college material. Using group and individual instruction in vocabulary, comprehension, and study skills, the students will increase their ability to survive academically, to profit, grow and succeed in all college courses, and to enjoy reading and learning. Units earned in this course do not count toward the associate degree and/or certain certificate requirements. This course has the option of a letter grade or pass/no pass. PREREQUISITE: Satisfactory score on the English placement examination.

	40175	Lec	HOL1	K Scimeca	3.2	3.0	MW	0945-1105
		Lab	HOL1	K Scimeca	1.0		F	0910-1000
Above class meets at the Hollister Briggs site.								
	40181	Lec	HOL1	K Scimeca	3.2	3.0	MW	0945-1105
		Lab	HOL1	K Scimeca	1.0		F	1010-1100
Above class meets at the Hollister Briggs site.								

↳ continued

CRN Type Room Instructor Hrs. Units Days Begin-End

ENGL 420 Continued

40249	Lec	PB14	S Hirasuna	3.2	3.0	TR	0945-1105
	Lab	LI120	S Hirasuna	1.0		R	1115-1205
40250	Lec	PB14	S Hirasuna	3.2	3.0	TR	0945-1105
	Lab	LI120	S Hirasuna	1.0		T	1115-1205
40253	Lec	HU103	D Luoma	3.2	3.0	MW	0500-0620
	Lab	HU103	D Luoma	1.0		M	0630-0720
40254	Lec	HU103	D Luoma	3.2	3.0	MW	0500-0620
	Lab	HU103	D Luoma	1.0		W	0630-0720

FIRST YEAR EXPERIENCE CLASSES ENGL 420 CLASSES (See ad on page 54):

15 40251 Lec PB14 K Warren 3.2 3.0 MW 1120-1240
 Lab LI171 K Warren 1.0 M 1010-1100
 This class is part of a Learning Community. If you enroll you must also enroll in ENGL 440, CRN 40260.

15 40252 Lec PB14 K Warren 3.2 3.0 MW 1120-1240
 Lab LI171 K Warren 1.0 T 1120-1210
 This class is part of a Learning Community. If you enroll you must also enroll in ENGL 440, CRN 40261.

ENGL 439 Basic Grammar and Reading

Transferable: No

This is a remediation course introducing basic reading and writing strategies, as well as study skills. Group and individual instruction will be used to build vocabulary, increase reading comprehension, develop study skills, and apply basic grammar to writing. Units earned in this course do not count toward the associate degree and/or certain certificate requirements. This is a pass/no pass course. ADVISORY: Assessment recommendation.

40255	L/L	PB14	S White	3.2	4.0	MW	0945-1105
	L/L	LI171	S White	3.3		F	0900-1205

ENGL 440 Basic Writing

Transferable: No

This is an intensive study and application of basic grammar, sentence, and essay writing skills within the context of composing short essays. Units earned in this course do not count toward the associate degree and/or certain certificate requirements. PREREQUISITE: Satisfactory score on the English placement examination.

40256	Lec	HU103	E Crook	3.2	3.0	MW	0945-1105
	Lab	LI120	E Crook	1.0		T	1010-1100
40257	Lec	HU103	E Crook	3.2	3.0	MW	0945-1105
	Lab	LI120	E Crook	1.0		R	1010-1100
40258	Lec	HOL1	K Scimeca	3.2	3.0	MW	1120-1240
	Lab	HOL1	K Scimeca	1.0		F	1110-1200

Above class meets at the Hollister Briggs site.

40259	Lec	HOL1	K Scimeca	3.2	3.0	MW	1120-1240
	Lab	HOL1	K Scimeca	1.0		F	1210-0100

Above class meets at the Hollister Briggs site.

40262	Lec	PB4	E Crook	3.2	3.0	TR	1120-1240
	Lab	LI120	E Crook	1.0		T	1250-0140

40263	Lec	PB4	E Crook	3.2	3.0	TR	1120-1240
	Lab	LI120	E Crook	1.0		R	1250-0140

40264	Lec	HU103	J Collins	3.2	3.0	TR	0600-0720
	Lab	LI120	J Collins	1.0		T	0730-0820

40265	Lec	HU103	J Collins	3.2	3.0	TR	0600-0720
	Lab	LI120	J Collins	1.0		R	0730-0820

FIRST YEAR EXPERIENCE CLASSES ENGL 440 CLASSES (See ad on page 54):

15 40260 Lec PB14 K Warren 3.2 3.0 MW 1250-0210
 Lab LI171 K Warren 1.0 W 1010-1100
 This class is part of a Learning Community. If you enroll you must also enroll in ENGL 420, CRN 40251.

15 40261 Lec PB14 K Warren 3.2 3.0 MW 1250-0210
 Lab LI171 K Warren 1.0 T 1220-0110
 This class is part of a Learning Community. If you enroll you must also enroll in ENGL 420, CRN 40252.

The Final Word!

Look for the Final Exams schedule on page 83.

ENGLISH COMPOSITION AND READING COURSE SEQUENCE

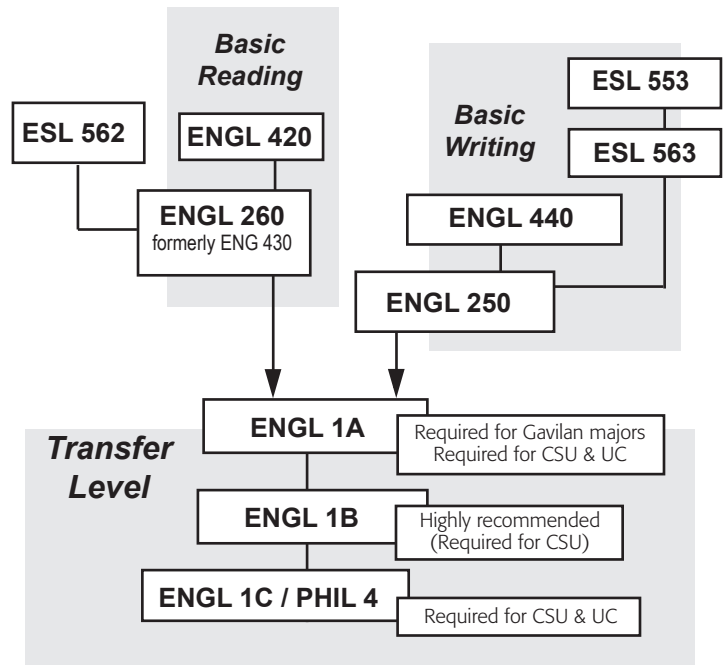

IT'S TIME TO PLAY!

English 9A, B, C

Poetry, Fiction & Drama



Research shows focussed play is good for mind, body and soul, making you more relaxed, and more productive. Come discover what you didn't know you wanted to say!

ENGL 749

WRITER'S WORKSHOP

Instructor: Kimberly Smith

Tuesday, 8:30 - 9:30 am
 Wednesday, 3:00-6:00 pm
 Thursday, 8:30 - 9:30 am

Meets in the Writing Center on the main campus in Gilroy.

See listing in the Noncredit section on page 92.

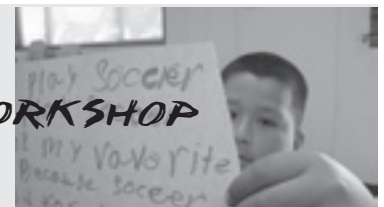

We help learners of all ages!

- Free tutoring for kids, teens and parents.
- Fun writing games and prompts.
- A relaxed and friendly atmosphere.

CRN Type Room Instructor Hrs. Units Days Begin-End

ENGLISH AS A SECOND LANGUAGE

All new ESL students must go through the ESL assessment process. See page 100.

Todos los nuevos estudiantes de ESL deben tomar el examen de nivelación de ESL. Consulte la página 100.

ESL 510A Basic ESL I

Transferable: No

This is an intensive, integrated-skill course for students with little English. Through listening, speaking, reading and writing activities, students learn to use the structures of English with increasing accuracy, while gaining basic life skills. ADVISORY: ESL Assessment Recommendation.

40001	Lec ARR	CE500	M Sanidad TBA	9.0 2.0	9.0	MTWRF	0950-1120
-------	------------	-------	------------------	------------	-----	-------	-----------

ESL 510B Basic ESL II

Transferable: No

This course is a continuation of ESL 510A. This is an intensive, integrated-skill program for students who function in a limited way in English. Through listening, speaking, reading and writing activities, students continue learning to use the structures of English with increasing accuracy, while gaining further basic life skills. ADVISORY: ESL 510A or ESL assessment recommendation.

40007	Lec ARR	CE500	K Campbell TBA	9.0 2.0	9.0	MTWRF	1130-0100
-------	------------	-------	-------------------	------------	-----	-------	-----------

ESL 521 Beginning ESL Listening/Speaking

Transferable: No

This course develops basic listening and speaking skills, moving from a functional survival context to academic readiness. Activities are directed at providing practice through listening exercises, role-play, pair work, small and large group discussion, interviews, and oral presentations. ADVISORY: ESL 510B or ESL Assessment Test Recommendation. Recommended concurrent enrollment in ESL 522 and 523.

40008	Lec ARR	HU101	K Baameur TBA	4.2 1.0	4.0	MWF	1105-1215
-------	------------	-------	------------------	------------	-----	-----	-----------

ESL 522 Beginning ESL Reading/Vocabulary

Transferable: No

This course begins the development of reading skills and vocabulary through the application of different reading strategies to a variety of selections on topics of interest to academically-bound students. ADVISORY: ESL 510B or 510C or Assessment recommendation. Recommended concurrent enrollment in ESL 521 and 523.

40009	Lec ARR	LI100	J Polizzotto TBA	3.2 2.0	3.0	TR	0940-1100
-------	------------	-------	---------------------	------------	-----	----	-----------

ESL 523 Beginning ESL Grammar/Writing

Transferable: No

This is a beginning grammar/writing course for students with very basic grammar. The focus is on basic grammatical structures, punctuation and sentence skills. ADVISORY: ESL 510B or ESL Assessment Test recommendation. Recommended concurrent enrollment in ESL 521 and ESL 522.

40010	Lec ARR	HU104	L Quijano TBA	5.2 1.0	5.0	MTWR	0820-0925
-------	------------	-------	------------------	------------	-----	------	-----------

ESL 528 Integrated Speaking/Listening I

Transferable: No

This is the first in a series of integrated skills courses designed to develop the listening, speaking and pronunciation skills of beginning ESL students. Activities, which include listening exercises, role-play, pair work, small and large group discussions, interviews, oral presentations and pronunciation drills (focusing on English sounds and rhythm), are presented in the context of relevant, contemporary and intellectually challenging themes. This course is designed especially for students with academic objectives but is highly appropriate for students with personal language goals, as well. PREREQUISITE: ESL 510B or ESL 503 or ESL Assessment recommendation.

40011	Lec	HU101	A Shelley	6.0	6.0	TR	0630-0930
-------	-----	-------	-----------	-----	-----	----	-----------

CRN Type Room Instructor Hrs. Units Days Begin-End

ESL 531 Intermediate ESL Listening/Speaking I

Transferable: No

In this course, listening and speaking skills are developed through extended listening exercises, open-ended dialogues, pair and group discussions, oral interviews, and oral reports. PREREQUISITE: ESL 521 or ESL 528 with a grade of 'C' or better or ESL Assessment Recommendation. Recommended concurrent enrollment in ESL 532 and 533.

40012	Lec ARR	HU104	N Cisneros TBA	4.2 1.0	4.0	MWF	0945-1055
-------	------------	-------	-------------------	------------	-----	-----	-----------

ESL 532 Intermediate ESL Reading/Vocabulary I

Transferable: No

This course continues the development of reading skills and vocabulary through the application of different reading strategies to a variety of selections on topics of interest to academically-bound students. PREREQUISITE: ESL 522 with a grade of 'C' or better or ESL assessment recommendation. Recommended concurrent enrollment in ESL 531 and 533.

40013	Lec ARR	HU104	M Bottega TBA	3.2 2.0	3.0	TR	0940-1100
-------	------------	-------	------------------	------------	-----	----	-----------

ESL 533 Intermediate ESL Grammar/Writing I

Transferable: No

This course involves the practice and refinement of sentence and paragraph skills, structure and punctuation. Students will learn basic use of the computer as a writing tool. PREREQUISITE: ESL 523 with a grade of C or better or ESL Assessment Test recommendation. ADVISORY: Recommended concurrent enrollment in ESL 531 and ESL 532.

40015	Lec ARR	LI100	B Lawn TBA	5.2 1.0	5.0	MTWR	1225-0130
-------	------------	-------	---------------	------------	-----	------	-----------

ESL 538 Integrated Listening/Speaking II

Transferable: No

This is the second in a series of integrated skills courses designed to develop the listening, speaking and pronunciation skills of low intermediate ESL students. Activities, which include listening exercises, role play, pair-work, small and large group discussions, interviews, oral presentations, and pronunciation (focusing on English sounds, rhythm and intonation), are presented in the context of relevant, contemporary and intellectually challenging themes. This course is designed especially for students with academic objectives but is highly appropriate for students with personal language goals as well. PREREQUISITE: ESL 528 or ESL 521 or ESL assessment recommendation.

40016	Lec	HU104	M Bottega	6.0	6.0	TR	0630-0930
-------	-----	-------	-----------	-----	-----	----	-----------

ESL 541 Intermediate ESL Listening/Speaking II

Transferable: No

This course expands listening and speaking skills through extended listening exercises, open-ended dialogues, pair and group discussions, oral interviews, and oral reports. Students broaden vocabulary while listening to and speaking in both formal and informal, conversational and academic situations. PREREQUISITE: ESL 531 or ESL 538 with a grade of 'C' or better or ESL assessment recommendation. Recommended concurrent enrollment in ESL 542 and 543.

40017	Lec ARR	HU104	N Cisneros TBA	4.2 1.0	4.0	MWF	1225-0135
-------	------------	-------	-------------------	------------	-----	-----	-----------

ESL 542 Intermediate ESL Reading/Vocabulary II

Transferable: No

This course begins the expansion of reading skills and vocabulary development through the application of different reading strategies to a variety of selections on topics of interest to academically-bound students including selections from literature. PREREQUISITE: ESL 532 with a grade of 'C' or better or ESL Assessment Recommendation. Recommended concurrent enrollment in ESL 541 and 543.

40018	Lec ARR	HU101	L Carrillo TBA	3.2 2.0	3.0	TR	0810-0930
-------	------------	-------	-------------------	------------	-----	----	-----------

ESL 543 Intermediate ESL Grammar/Writing II

Transferable: No

This course involves the expansion of sentence and paragraph skills, structure, and punctuation. Students will learn basic use of the computer as a writing tool. PREREQUISITE: ESL 533 with a grade of C or better or ESL assessment recommendation. ADVISORY: Recommended concurrent enrollment in ESL 541 and ESL 542.

40019	Lec ARR	HU101	K Campbell TBA	5.2 1.0	5.0	TWRF	0945-1050
-------	------------	-------	-------------------	------------	-----	------	-----------

CRN Type Room Instructor Hrs. Units Days Begin-End

ESL 546 Introduction to Computers for ESL Students

Transferable: No

Introduction to basic computer hardware functions and terminology; overview of Windows operating environment and word processing for ESL students. ADVISORY: CSIS 122. Eligible for Gavilan College ESL Program Intermediate.

40020 Lec BU119 Staff 1.0 1.0 W 1115-1205

ESL 548 Integrated Listening/Speaking III

Transferable: No

This is the third in a series of integrated skills courses designed to develop listening, speaking and pronunciation skills of high intermediate ESL students. Activities, which include listening exercises, role-play, pair work, small and large group discussions, interviews, oral presentations, and pronunciation drills (focusing on English sounds, rhythm and intonation), are presented in the context of relevant, contemporary, and intellectually challenging themes. This course is designed especially for students with academic objectives but is highly appropriate for students with personal language goals, as well. PREREQUISITE: ESL 538 or ESL 531 or ESL assessment recommendation.

40027 Lec LI100 L Nguyen 6.0 6.0 TR 0630-0930

ESL 552 Advanced ESL Reading/Vocabulary I

Transferable: No

This course focuses on academic and critical thinking skills needed to increase reading comprehension and efficiency. Emphasis is on analyzing, making inferences, taking notes, supporting opinions, summarizing and expanding vocabulary. Readings are from academic texts and literature. PREREQUISITE: ESL 542 with a grade of 'C' or better or ESL assessment recommendation. Recommended concurrent enrollment in ESL 553 and 554.

40021 Lec LI100 B Lawn 4.2 4.0 MWF 0945-1055

ESL 553 Advanced ESL Composition I

Transferable: No

This course is a composition course for ESL students that develops college composition skills through a review of the parts and elements of the English paragraph and an introduction to the essay form. The course focuses on the development of a paragraph and expands to the writing of multiple paragraphs in an essay. Basic rhetorical patterns and methods of organization are covered using the multiple-draft approach to writing. PREREQUISITE: ESL 543 with a grade of C or better or ESL Assessment Test recommendation. ADVISORY: Recommended concurrent enrollment in ESL 552 and ESL 554.

40022 Lec LI100 J Polizzotto 5.2 5.0 MTWR 0810-0915
ARR TBA 1.0

ESL 554 Advanced ESL Grammar I

Transferable: No

This course is designed to help students improve their grammar usage so that they will be able to expand their use of grammar structures in oral and written communication. Students begin the study of more sophisticated grammar structures such as past and future perfect, passive voice, and modal auxiliaries for past time, and they review perfect and modals for present and future time. Students will enhance their understanding of grammar by comparing and contrasting new and previously encountered structures and better appreciate the subtleties of English grammar. PREREQUISITE: ESL 543 with a grade of 'C' or better or ESL Assessment Test Recommendation. ADVISORY: Recommended concurrent enrollment in ESL 552 and ESL 553.

40023 Lec HU104 N Cisneros 5.2 5.0 MTRF 1110-1215
ARR TBA 1.0

ESL 562 Advanced ESL Reading/Vocabulary II

Transferable: No

This course prepares ESL students for mainstream college classes by reviewing a variety of reading skills, strategies, and topics from different academic disciplines. Students expand their academic vocabulary and read short stories or a novel for literary appreciation. PREREQUISITE: ESL 552 with a grade of 'C' or better or ESL assessment recommendation. Recommended concurrent enrollment in ESL 561 and/or ESL 564 and ESL 563.

40024 Lec HU101 K Baameur 4.2 4.0 MWF 0810-0920

Check Out Early & Late Start Classes! Page 90.

Register anytime before the first day of class.
Check the dates printed under the class CRN number.

OVERVIEW of ESL COURSES

NON CREDIT

LIFE SKILLS

ESL 777

ESL 778

ESL 779

ESL 780

ESL 781

ESL 782

VOCATIONAL

VESL ESL 704A/B

To move from noncredit to credit ESL classes students must take an ESL assessment.

CREDIT - ACADEMIC TRACK

¿Es el inglés su Segundo Idioma?

Consulte la página 100 para información en Español sobre el examen de evaluación de ESL.

Basic

510A

510B

Beginning

521 L/S

522R

523GW

Intermediate I

531 L/S

532R

533GW

Intermediate II

541 L/S

542R

543GW

Advanced I

552R

553W

Advanced II

561 L/S

562R

563W

DAYTIME CLASSES

EVENING CLASSES

527RW 528L/S

537RW 538L/S

547RW 548L/S

554G

564G

SUPPLEMENTARY ESL COURSES:

- ESL 546 Intro Computers/ESL
- ESL 556 Intro Competency/ESL
- ESL 581 Pronunciation I
- ESL 582 Pronunciation II
- ESL 584 Culture through Film
- ESL 585 Editing for ESL Writers

ENGL 260

ENGL 250

ACADEMIC PROGRAMS

or

VOCATIONAL PROGRAMS

CRN Type Room Instructor Hrs. Units Days Begin-End

ESL 563 Advanced ESL Composition II

Transferable: No

This course, which is designed for ESL students, refines and further expands college composition skills through the writing of essays using the multiple-draft approach to writing. The course focuses on the structuring and development of an essay with the use of personal examples. Students write in response to a variety of prompts using different rhetorical patterns such as classification, cause/effect, and comparison/contrast. PREREQUISITE: ESL 553 with a grade of "C" or better or ESL Assessment Test recommendation. ADVISORY: Recommended concurrent enrollment in ESL 562 and ESL 564.

40025 Lec MA102 L Quijano 5.2 5.0 MTWR 0945-1050
ARR TBA 1.0

ESL 564 Advanced ESL Grammar II

Transferable: No

This course is designed to expand grammar usage to include adjective, noun, and adverb clauses in oral and written communication. Students learn the meaning and use of clause connectors and are introduced to conditionals, both real and unreal. These grammar structures constitute some of the most complex structures in English and expose students to a rich variety of structures that can effectively enhance their oral and written expression. PREREQUISITE: ESL 554 with a grade of 'C' or better or ESL Assessment Recommendation. ADVISORY: Recommended concurrent enrollment in ESL 562 and ESL 563.

40026 Lec LI100 B Lawn 5.2 5.0 TWRF 1110-1215
ARR TBA 1.0

CRN	Type	Room	Instructor	Hrs.	Units	Days	Begin-End
-----	------	------	------------	------	-------	------	-----------

ESL 581 ESL Pronunciation I

Transferable: No

This is a high-beginning/low-intermediate ESL Pronunciation Course. Students will participate in a variety of communicative activities designed to improve their pronunciation. This course focuses on clear pronunciation of vowels, consonants, diphthongs and clusters, accurate word stress and rhythm, and the connection between spelling and pronunciation. It also introduces the concept of sentence intonation. This is a pass/no pass course. ADVISORY: ESL 510B or ESL Assessment Test Recommendation.

40486	L/L	HOL1	N Cisneros	2.0	2.0	TR	0845-0945
-------	-----	------	------------	-----	-----	----	-----------

Above class meets at the Hollister Briggs site.

Film: see ENGL 2C, HUM 3, 4, 10
Foreign Languages: See French (FRNH),
Japanese (JPN) and Spanish (SPAN)

FRENCH**FRNH 1B Elementary French**

Transferable: CSU, UC; CSU-GE:C2, IGETC:6A; GAV-GE:C2

Continuation of French 1A with further development of the four skills of understanding, speaking, reading, and writing. Continued emphasis on culture. PREREQUISITE: French 1A, or equivalent.

40563	Lec	PB13	M Sanidad	5.2	5.0	MTWR	0810-0915
	ARR		M Sanidad	2.8			

FRNH 23 Independent Study

Transferable: CSU

Designed to afford selected students specialized opportunities for exploring areas at the independent study level. The courses may involve extensive library work, research in the community, or special projects. May be repeated until six units of credit are accrued. This course has the option of a letter grade or pass/no pass. REQUIRED: The study outline prepared by the student and the instructor must be filed with the department and the dean.

40564	Ind	PB11	M Sanidad	1.0			
-------	-----	------	-----------	-----	--	--	--

GEOGRAPHY**GEOG 1 Physical Geography**

Transferable: CSU, UC; CSU-GE:B1, B3, IGETC:5A; GAV-GE:B1, B3; CAN:GEOG6

An introductory study of the basic physical elements of geography including climate, land forms, soils, water, and natural vegetation. The laboratory will include the tools and methods of geographers. ADVISORY: Eligible for English 250 and English 260.

40284	L/L	HOL2	D Willahan	5.4	3.0	MW	0945-1210
-------	-----	------	------------	-----	-----	----	-----------

Above class meets at the Hollister Briggs site.

GEOLOGY**GEOL 1 Introduction to Geology**

Transferable: CSU, UC; CSU-GE:B1, B3, IGETC:5A; GAV-GE:B1, B3; CAN:GEOL2

A study of the earth and the physical properties which modify the earth; minerals, rocks, geologic structures and processes. ADVISORY: Eligible for English 250 and English 260.

40464	L/L	PB7	D Willahan	6.6	4.0	MW	1250-0355
-------	-----	-----	------------	-----	-----	----	-----------

Government: see Political Science
Graphic Arts: see Art, CGD, CSIS, Digital Media

CRN	Type	Room	Instructor	Hrs.	Units	Days	Begin-End
-----	------	------	------------	------	-------	------	-----------

GUIDANCE**GUID 1 Self-Assessment and Career Development**

Transferable: CSU; CSU-GE:E2; GAV-GE:E2

This course is designed to assist the student in learning more about personal values, personality, interests, exploration of career choice, and occupational opportunities through the use of various personal assessment instruments. The delivery options for this course also include online and self-paced formats. This course is also listed as PSYC 5. ADVISORY: Eligible for English 250 and English 260. \$12 fee will be charged for career assessment materials.

40166	Lec	HU105	J Godley	3.2	3.0	TR	1250-0210
-------	-----	-------	----------	-----	-----	----	-----------

ONLINE:

 40168 Online L Tenney 3.0 Start by going to <http://www.gavilan.edu/disted>. You must have an email account to take this course. Unless you have made prior arrangements with the instructor, you MUST log on by 11:59 pm on the first day of the course. Late adds must login within 24 hours of adding this course. If you miss the deadline you may be dropped. For help, contact your instructor or email disted@gavilan.edu.

PUENTE PROGRAM:

40170	Lec	LS106	C Marquez	3.2	3.0	MW	1120-1240
-------	-----	-------	-----------	-----	-----	----	-----------

Students enrolled in this class will participate in the PUENTE Program and will need to complete 10 hours of mentoring. Required: Complete an application with the PUENTE counselor prior to registration. This class is part of a learning community. Students must also enroll in ENGL 1A, CRN 40041. See ad on page 61.

GUID 22 Field Work and Service

Transferable: CSU

Supervised field work within the college and with local agencies. Students serve in useful group activities in leadership roles prescribed for them by faculty or community agencies. A maximum of six units may be completed. This is a pass/no pass course. REQUIRED: Learning contracts must be filled out and signed by the student and the supervising instructor.

40422	Fid Ex	LI117	S STAFF	1.0			
-------	--------	-------	---------	-----	--	--	--

Contact the Disability Resource Center (DRC) office.

GUID 191A Workplace Skills

Transferable: CSU

Workplace Skills teaches skills vital to workplace success. The topic for 191A is Interpersonal Communication. Need not be taken in sequence. This is a pass/no pass course.

40867	Lec	MHG8	F Mendez	3.9	1.0	F	0900-1235
-------	-----	------	----------	-----	-----	---	-----------

04/29/11 - 05/27/11 Above class meets at Morgan Hill Community site. ROP course.

40866	Lec	HOL3	F Mendez	3.9	1.0	M	0600-0935
-------	-----	------	----------	-----	-----	---	-----------

04/25/11 - 05/23/11 Above class meets at the Hollister Briggs site. ROP course.

GUID 530 Job Readiness

Transferable: No

This course is designed to provide a comprehensive, well-organized approach to assist individuals with the identification of occupational choices and the development of job readiness skills necessary to obtain and maintain employment in a competitive or supported work setting. May be repeated twice for credit. This course has the option of a letter grade or pass/no pass.

40423	Lec	BU103	L Franklin	3.2	3.0	MW	0945-1105
-------	-----	-------	------------	-----	-----	----	-----------

This Service Learning section involves community work. See page 19 for more information.

GUID 550 Supervised Tutoring

Transferable: No

Laboratory class emphasizing college learning skills, appropriate study techniques, and learning assistance utilizing one-to-one or small group tutorial.

40172	Lab	Computer Place					
40173	Lab	Digital Media Lab					
40174	Lab	Health Occupations Lab					
40177	Lab	Math Lab					
40178	Lab	Tutoring Center					
40179	Lab	Writing Center					

CRN Type Room Instructor Hrs. Units Days Begin-End

GUID 557 Learning Skills Evaluation

Transferable: No

This course provides an evaluation of the student's cognitive/perceptual abilities and basic skills academic achievement. The evaluation results are used to determine the student's eligibility for Learning Disabilities Services, to develop individual educational plans, and to improve the student's understanding of their own learning strengths and weaknesses. The evaluation is conducted on a one-to-one basis by appointment. Students receive skills training to assist them with their learning difficulties. Units earned in this course do not count toward the associate degree and/or certificate requirements. This is a pass/no pass course.

40424 Lab LI117 L Burgman/ R Overson .5
Make an appointment with the Disability Resource Center (DRC) Office. Open Entry/Open Exit

GUID 558 Learning Skills Laboratory

Transferable: No

The Learning Skills Laboratory is designed to assist students who are eligible to receive Learning Disabilities Services and/or have demonstrated academic deficits. The course content is individualized and based on Student Educational Contracts which are developed for each student. Students receive supplemental instruction, academic support, and learning strategy suggestions appropriate for their individual cognitive, perceptual, and academic strengths and weaknesses. Units earned do not count towards the associate degree and/or certificate requirements. This is a pass/no pass course. ADVISORY: Completion of Guidance 557 or demonstrated academic deficit.

40444	Lab	LI116	R Overson / L Burgman	.5		Open Entry/Open Exit
40472	Lab	LI116	R Overson / L Burgman	1.0		Open Entry/Open Exit
40473	Lab	LI116	R Overson / L Burgman	2.0		Open Entry/Open Exit
40470	Online		R Overson / L Burgman	.5		Open Entry/Open Exit

Start by going to <http://www.gavilan.edu/disted>. You must have an email account to take this course. For help, contact your instructor or email disted@gavilan.edu. Open Entry/Open Exit.

GUID 560 Individualized Learning Skills Development

Transferable: No

This class is designed to teach individual learning skills development to students who are eligible to receive learning disability services. The course content includes organizational skills, fundamental critical thinking and basic college survival skills. ADVISORY: Completion of GUID 557 or demonstrated academic deficit.

40478 Lab BU103 R Overson 3.2 1.0 TR 1120-1240

GUID 562 Directed Study Lab in Pre-Algebra

Transferable: No

This course is designed for students who have demonstrated difficulty in mastering basic mathematics or pre-algebra and who are eligible to receive Learning Disability Services. Course content parallels Mathematics 400 and Mathematics 402. Material is presented in a concrete, multi-sensory manner, and the lab environment allows opportunity for immediate practice, questions, repetition, and review. This is a pass/no pass course. COREQUISITE: Concurrent enrollment in MATH 400 or MATH 402 is required. ADVISORY: Completion of GUID 557 and/or a demonstrated deficit in arithmetic. Recommended for students with verified learning disability.

40477 Lab BU103 L Burgman 3.2 1.0 MW 1120-1240

GUID 563 Directed Study Lab in Algebra

Transferable: No

This course is designed for students who have demonstrated difficulty mastering elementary algebra and who are eligible to receive Learning Disability Services. Course content parallels Mathematics 205A and 205B. Material is presented in a concrete, multi-sensory manner, and the lab allows opportunity for immediate practice, questions, repetition, and review. This is a pass/no pass course. Concurrent enrollment in Math 205A, Math 205B or Math 205 is required.

40479 Lab APE120 L Burgman 3.2 1.0 TR 0945-1105

GUID 565 Directed Study Lab in Intermediate Algebra

Transferable: No

This course is designed for students who have demonstrated difficulty mastering intermediate algebra and who are eligible to receive Learning Disability Services. Course content parallels Mathematics 233A and 233B. Material is presented in a concrete, multi-sensory manner, and the lab allows opportunity for immediate practice, questions, repetition and review. This is a pass/no pass course. Concurrent enrollment in Math 233A, Math 233B or Math 233 is required.

40480 Lab BU103 R Overson 3.2 1.0 TR 0945-1102

Are you a self-confident and self-motivated student?

Become a Rambassador!

Join the Student Ambassador Program and...

- ➔ Join the Outreach and Recruitment Coordinator on local high school visits, at community and on campus events such as GavFest, Science Alive, Transfer Day and Graduation!
- ➔ Learn about college processes, such as admissions, financial aid, registration and Gavilan College's programs and services. Assist new students and make them feel welcome.
- ➔ Help guide visitors on campus tours.

For more information and requirements on becoming a Gavilan College Student Rambassador, please call Lynda Kerr at (408) 846-4993 or e-mail lkerr@gavilan.edu.



The Puente Project is a two-semester program that combines three components: writing, counseling and mentoring to support students to transfer to four-year universities and colleges. The Guidance 6 course focuses on self assessment and career development. The English 1A course focuses on Mexican American/Latino literature. The program also includes a student leadership conference, university visits and mentor/student socials. The program is open to all eligible students. For more information, call Celia Marquez, Puente Co-Coordinator at 408-848-4807.

Required: Complete a program application with the Puente Counselor prior to registration.

GUID 1	CRN 40170	Marquez C	MW	1120A-1240P
Students will need to complete 10 hours of mentoring.				
ENGL1A	CRN 40041	Sandler S	TuTh	1120A -1240P

Rho Alpha Mu



HONOR SOCIETY

Gain eligibility for special scholarships and awards!

Meet other honors students!

Serve the community!

Faculty Advisor,
Jennifer Nari
(408) 848-4897

Must have a GPA of at least 3.0 for twelve units. Incoming freshmen must have attained a 3.5 cumulative GPA from high school.



CRN	Type	Room	Instructor	Hrs.	Units	Days	Begin-End
-----	------	------	------------	------	-------	------	-----------

HEALTH EDUCATION

HE 1 Health Education

Transferable: CSU, UC; CSU-GE:E2; GAV-GE:E2

This course focuses on attaining individual awareness, critical-thinking skills and self-responsibility relating to personal health. The interaction of individual physical, psychological, social, emotional, spiritual and environmental factors in determining health status is developed through integration of major concepts. This course has the option of a letter grade or pass/no pass. ADVISORY: Eligible for English 250 and English 260.

40052	Lec	LS106	S Dodd	3.2	3.0	TR	0945-1105
	40053	Online	S Quatre	3.0	See information above about online classes.		
	40054	Online	S Quatre	3.0	See information above about online classes.		

HE 2 Human Sexuality

Transferable: CSU, UC; CSU-GE:E2; GAV-GE:E2, F

Assists students in gaining increased knowledge, appreciation, and respect for their own sexuality, as well as others. Approved by the Board of Registered Nursing for 54 hours of continuing education credit (Provider #00892). ADVISORY: Eligible for English 250 and English 260

40055	Lec	LS106	R Monaco	3.3	3.0	R	0600-0905
	40056	Online	S Quatre	3.0	See information above about online classes.		

HISTORY

HIST 1 United States History through Reconstruction

Transferable: CSU, UC; CSU-GE:C2, D6, IGETC:3B, 4F, 7B; GAV-GE:C2, D2; CAN:HIST8, HIST SEQ B

History of the United States from the time before European contact with the Americas through Reconstruction. Emphasis will be placed on distinctive patterns of political, economic, social, intellectual, and geographic developments within their global context. At the conclusion of the course, the student should understand major themes in the history of the United States, and be able to explain various ways in which ideas about federal vs. state power, ethnicity, class, and gender divisions have influenced the nation's development. This course has the option of a letter grade or pass/no pass. ADVISORY: Eligible for English 250 and English 260.

40287	Lec	PB8	D Kier	3.2	3.0	TR	0810-0930
40286	Lec	PB3	E Luna	3.2	3.0	MW	0945-1105
40285	Lec	MHG12	C Mosher	3.2	3.0	MW	0945-1105
Above class meets at Morgan Hill Community site.							
40289	Lec	HOL2	E Luna	3.2	3.0	TR	1120-1240
Above class meets at the Hollister Briggs site.							
40288	Lec	HOL5	E Luna	3.3	3.0	T	0600-0905
Above class meets at the Hollister Briggs site.							

HIST 2 United States History Reconstruction to the Present

Transferable: CSU, UC; CSU-GE:C2, D6, IGETC:3B, 4F, 7B; GAV-GE:C2, D2; CAN:HIST10, HIST SEQ B

History of the United States from Reconstruction to the present. Emphasis will be placed on distinctive patterns of political, economic, social, intellectual, and geographic developments within their global context. At the conclusion of the course, the student should understand major themes in the history of the United States, and be able to explain various ways in which ideas about federal vs. state power, ethnicity, class, and gender divisions have influenced the nation's development. This course has the option of a letter grade or pass/no pass. ADVISORY: Eligible for English 1A.

40293	Lec	PB5	L Halper	3.2	3.0	TR	0945-1105
40294	Lec	HOL2	E Luna	3.2	3.0	TR	0945-1105
Above class meets at the Hollister Briggs site.							
40291	Lec	MHG12	C Mosher	3.2	3.0	MW	1120-1240
Above class meets at Morgan Hill Community site.							
40292	Lec	PB3	L Halper	3.2	3.0	MW	0230-0350
	40295	Online	L Guardino	3.0	See information above about online classes.		

CRN	Type	Room	Instructor	Hrs.	Units	Days	Begin-End
-----	------	------	------------	------	-------	------	-----------



ONLINE CLASSES: Start by going to <http://www.gavilan.edu/disted>. You must have an email account to take an online course. Unless you have made prior arrangements with the instructor, you MUST log on by 11:59 pm on the first day of the course. Late adds must login within 24 hours of adding this course. If you miss the deadline you may be dropped. For help, contact your instructor or email disted@gavilan.edu.

HIST 4A History of World Societies, Before 1500

Transferable: CSU, UC; CSU-GE:C2, D6, IGETC:3B, 4F; GAV-GE:C2, D2

A study of major elements in the development of and interactions between world societies, from the first organization of community to the dawn of the Renaissance. Students will comparatively analyze social, cultural, geographic, economic, demographic, technological, environmental, and political developments that moved humans from nomadic to agri-technological and urban lives. This course has the option of a letter grade or pass/no pass. ADVISORY: English 250 and English 260.

40296	Lec	PB8	L Halper	3.2	3.0	TR	1250-0210
-------	-----	-----	----------	-----	-----	----	-----------

HIST 6 Women's Lives in Recent United States History

Transferable: CSU, UC; CSU-GE:C2, D4, D6, IGETC:3B, 4F; GAV-GE:C2, D2

The class examines the construction of womanhood in the US during the twentieth century. The class explores the effects of gender, ethnicity, class, and sexual orientation upon women's experiences. Students will study the contributions of various individual women and groups of women in creating the modern United States, and will analyze social, political, economic, and cultural forces affecting women to both join and resist movements for social change. Students will also learn to apply contemporary feminist theory to traditional historical approaches. ADVISORY: English 250

40297	Lec	PB8	L Guardino	3.3	3.0	W	0600-0905
-------	-----	-----	------------	-----	-----	---	-----------

HIST 12 Mexican American Cultural History

Transferable: CSU, UC; CSU-GE:C2, D3, D6, IGETC:3B, 4F; GAV-GE:D2, F

The Mexican American experience as influenced by society in the United States. Emphasis will be on the historical and contemporary contributions made by the Indian, Spanish, Mexican, and Mexican American. Emphasis will also be on the social, economic, and political milieu of the Mexican American within the context of the American society. This course has the option of a letter grade or pass/no pass. This course is also listed as HUM 12. ADVISORY: Eligible for English 1A.

40290	Lec	PB3	E Luna	3.2	3.0	MW	1250-0210
-------	-----	-----	--------	-----	-----	----	-----------

HUMANITIES

HUM 4 Introduction to American Cinema

Transferable: CSU, UC; CSU-GE:C2, IGETC:3B; GAV-GE:C2

This introductory course in film studies is a survey of the American film industry as an art form, as an industry, and as a system of representation and communication. The course explores how Hollywood films work technically, aesthetically, and culturally to reinforce and challenge America's national self-image. ADVISORY: English 440

	40277	Online	G Richards	3.0	See information above about online classes.		
---	-------	--------	------------	-----	---	--	--

HUM 10 Approaches to Contemporary Film

Transferable: CSU, UC; CSU-GE:C1, C2, IGETC:3B; GAV-GE:C1, C2

Approaches to Contemporary Film examines theories of film criticism as they apply to films from 1960 to the present. Students learn technical, visual, classical, historical, cultural, ideological, and aesthetic approaches to film and sample from a representative list of foreign and domestic movies. Special emphasis is given to new voices from non-American sources and to emerging voices in American cinema. ADVISORY: Eligibility for English 250 and 260.

40273	Lec	PB5	G Richards	3.2	3.0	MW	1120-1240
40274	Lec	PB5	G Richards	3.2	3.0	TR	1250-0210

Please help protect Gavilan's park-like setting by properly disposing of litter and recycling.

CRN Type Room Instructor Hrs. Units Days Begin-End

HUM 12 Mexican American Cultural History
Transferable: CSU, UC; CSU-GE:C2, D3, D6, IGETC:3B, 4F; GAV-GE:D2, F
 The Mexican American experience as influenced by society in the United States. Emphasis will be on the historical and contemporary contributions made by the Indian, Spanish, Mexican, and Mexican American. Emphasis will also be on the social, economic, and political milieu of the Mexican American within the context of the American society. This course has the option of a letter grade or pass/no pass. This course is also listed as HIST 12. **ADVISORY:** Eligible for English 1A.

40868 Lec PB3 E Luna 3.2 3.0 MW 1250-0210

HUM 23 Independent Study

Transferable: CSU
 Designed to afford selected students specialized opportunities for exploring areas at the independent study level. The courses may involve extensive library work, research in the community, or special projects. May be repeated until six units of credit are accrued. This course has the option of a letter grade or pass/no pass. **REQUIRED:** The study outline prepared by the student and the instructor must be filed with the department and the dean.

40275 Ind HU111 G Richards 1.0
 40276 Ind HU111 G Richards 1.0

Information Science: see CSIS

Intercollegiate Athletics: see Physical Education

JAPANESE

JPN 1A Elementary Japanese

Transferable: CSU, UC; CSU-GE:C2; GAV-GE:C2
 Beginning course with emphasis on understanding and speaking Japanese; introduction to reading and writing Japanese. This course will also introduce students to Japanese culture and institutions. This course has the option of a letter grade or pass/no pass.

40648 Lec PB14 T Sakai 5.4 5.0 MW 0230-0455
 ARR T Sakai 2.5

JPN 1B Elementary Japanese

Transferable: CSU, UC; CSU-GE:C2, IGETC:6A; GAV-GE:C2
 Continue Japanese 1A with an emphasis on understanding, speaking, reading, and writing Japanese. This course will continue to introduce students to Japanese culture and institutions. This course has the option of a letter grade or pass/no pass. **PREREQUISITE:** Japanese 1A or equivalent.

40649 Lec PB14 T Sakai 5.4 5.0 TR 0230-0455
 ARR T Sakai 2.5

JPN 23 Independent Study

Transferable: CSU
 Designed to afford selected students specialized opportunities for exploring areas at the independent study level. The course may involve extensive library work, research in the community, or special projects. May be repeated until six units of credit are accrued. This course has the option of a letter grade or pass/no pass. **REQUIRED:** The study outline prepared by the student and the instructor must be filed with the department and the dean.

40650 Ind PB11 T Sakai 2.0

JOURNALISM

JOUR 10 Mass Media and Society

Transferable: CSU, UC; CSU-GE:C2, D0, IGETC:4J; GAV-GE:C2, D2; CAN:JOUR4
 This course helps students understand the 20th century revolution in mass media by focusing on the history, economics and social impact of the newspaper, book publishing, magazine, film, television, public relations, advertising and music industries. Students will study audience, propaganda and mass communication theory; and discuss new technology, ethnic media in the United States, ethical issues and attempts to regulate or control the media. Honors students will complete more in-depth analysis of media issues and will finish a media-related research project. This course is also listed as SOC 10. This course has the option of a letter grade or pass/no pass. **ADVISORY:** English 250, English 260.

40565 Lec AR103 J Janes 3.2 3.0 MW 0810-0930



Hands on Acting! Kids on Stage!
 Theatre and TV Performing Arts Day Camps

For more information:
 Call us: (408) 612-2057
 Visit our website: www.gavilan.edu/star
 Email us: stargav@gavilan.edu

STAR is a place where kids and staff can feel safe.
 Safe to express their thoughts, ideas and feelings.
 Safe to move and dance and sing.
 Safe to create moments to share.
 Safe to celebrate their lives.
 Safe to grow and develop their potential as performers.
 Safe to laugh, learn and have fun.
 Safe in body, mind and spirit.

Day of Beauty for Men & Women

only \$30
 w/o coupon - \$35

- INCLUDES**
- ✓ Hair cut & style
 - ✓ Deep conditioning
 - ✓ Scalp treatment
 - ✓ Manicure
 - ✓ Facial
 - ✓ Eyebrow arch
 - ✓ Makeup
 - no substitutions*

- DISCOUNTS**
- Senior Citizens: 20% daily
 - Staff/Students: 10% daily
 - Discounts not applicable to DAILY SPECIALS, Special perms or any service under \$6.00

- DAILY SPECIALS**
- | | | |
|---|---|--|
| <p>Wed:
 Hair Cut ONLY - \$5.50
 Hair Cut & Style - \$10</p> | <p>Thurs/Fri:
 All Basic Perms - 20% off
 Plain Manicure & Pedicure - \$11</p> | <p>Wed/Fri:
 Hair Color - 20% off</p> |
|---|---|--|

For appointments call 408-842-5055

All work performed by students supervised by instructors. Discounts not applicable to daily specials, special color, special perms or any service under \$6. Not valid with any other discounts.

CRN Type Room Instructor Hrs. Units Days Begin-End

JOUR 18A Working on the Newspaper

Transferable: CSU; GAV-GE:C1
 Students interview, write, photograph and do computer assisted design and graphics for the college newspaper, The Gavilan Press. In doing this, they provide the community with an important first amendment forum, learn and educate about the first amendment rights and responsibilities, and acquire journalistic skills, ethics, and habits. **ADVISORY:** Eligible for English 1A. Typing ability.

40631	Lab	HU106	J Janes	2.6	2.0	MW	0230-0335
40632	Lab	HU106	J Janes	5.4	3.0	MW	0230-0455
40633	Lab	HU106	J Janes	5.4	4.0	MW	0230-0455
	ARR		J Janes	3.3			
40634	Lab	HU106	J Janes	5.4	5.0	MW	0230-0455
	ARR		J Janes	6.6			

CRN Type Room Instructor Hrs. Units Days Begin-End

JOUR 18B Working on the Newspaper

Transferable: CSU; GAV-GE:C1

Students interview, write, photograph and do computer assisted design and graphics for the college newspaper, The Gavilan Press. In doing this, they provide the community with an important first amendment forum, learn and educate about the first amendment rights and responsibilities and acquire journalistic skills, ethics and habits. ADVISORY: Journalism 18A.

40635	Lab	HU106	J Janes	2.6	2.0	MW	0230-0335
40636	Lab	HU106	J Janes	5.4	3.0	MW	0230-0455
40637	Lab ARR	HU106	J Janes J Janes	5.4 3.3	4.0	MW	0230-0455
40638	Lab ARR	HU106	J Janes J Janes	5.4 6.6	5.0	MW	0230-0455

JOUR 18C Working on the Newspaper

Transferable: CSU; GAV-GE:C1

Students interview, write, photograph and do computer assisted design and graphics for the college newspaper, The Gavilan Press. In doing this, they provide the community with an important first amendment forum, learn and educate about the first amendment rights and responsibilities and acquire journalistic skills, ethics and habits. ADVISORY: Journalism 18B.

40639	Lab	HU106	J Janes	2.6	2.0	MW	0230-0335
40640	Lab	HU106	J Janes	5.4	3.0	MW	0230-0455
40641	Lab ARR	HU106	J Janes J Janes	5.4 3.3	4.0	MW	0230-0455
40642	Lab ARR	HU106	J Janes J Janes	5.4 6.6	5.0	MW	0230-0455

JOUR 18D Working on the Newspaper

Transferable: CSU; GAV-GE:C1

Students interview, write, photograph and do computer assisted design and graphics for the college newspaper, The Gavilan Press. In doing this, they provide the community with an important first amendment forum, learn and educate about the first amendment rights and responsibilities and acquire journalistic skills, ethics and habits. ADVISORY: Journalism 18C.

40643	Lab	HU106	J Janes	2.6	2.0	MW	0230-0335
40644	Lab	HU106	J Janes	5.4	3.0	MW	0230-0455
40645	Lab ARR	HU106	J Janes J Janes	5.4 3.3	4.0	MW	0230-0455
40646	Lab ARR	HU106	J Janes J Janes	5.4 6.6	5.0	MW	0230-0455

JOUR 23 Independent Study

Transferable: CSU; GAV-GE:C1

Designed to afford selected students specialized opportunities for exploring areas at the independent study level. The courses may involve extensive library work, research in the community, or special projects. May be repeated until six units of credit are accrued. This course has the option of a letter grade or pass/no pass. REQUIRED: The study outline prepared by the student and the instructor must be filed with the department and the dean.

40647	Ind	HU106	J Janes	2.0			
-------	-----	-------	---------	-----	--	--	--

JOUR 190 Occupational Work Experience/Journalism

Transferable: CSU

Occupational work experience for students who have a job related to their major. A training plan is developed cooperatively between the employer, college and student. (P/NP grading) 75 hours per semester paid work = 1 unit. 60 hours non-paid (volunteer) work per semester = 1 unit. May be taken for a maximum total of 16 units. Minimum 2.00 GPA. REQUIRED: Declared vocational major.

Mandatory course orientation for the following classes will be conducted February 11: 2-3 pm, March 1: 4:30-5:30 pm, April 12: 12 pm. Meetings will be held in the Student Center-North/South Lounge. Students must attend one of the three meetings. www.gavilan.edu/cwe for assignments and details. Please contact Susan Sweeney, CWE Coordinator at ssweeney@gavilan.edu for more information.

40807	Wrk Ex	LI101A	S Sweeney	1.0			
40808	Wrk Ex	LI101A	S Sweeney	2.0			
40809	Wrk Ex	LI101A	S Sweeney	3.0			
40810	Wrk Ex	LI101A	S Sweeney	4.0			

CRN Type Room Instructor Hrs. Units Days Begin-End

JPA Fire Technology and JPA Law Enforcement

see ad below:



Careers in

- Law Enforcement
- Fire Technology
- Probation Officer
- Dispatcher
- Corrections Officer
- Juvenile Hall Counselor

Gavilan College is a member of the South Bay Regional Public Safety Training Consortium. This consortium is funded by all colleges regionally to provide specific vocational training which may require special facilities, special training conditions or is presented outside of the schedules of regular college classes. For more information call 408-270-6458.

Law Enforcement: see also Administration of Justice

LIBRARY

LIB 6 Web Page Authoring I

Transferable: CSU; GAV-GE:E2

A introduction to using Hypertext Mark-Up Language (HTML) and Extensible HTML (XHTML) to create web pages which can be uploaded and displayed on the World Wide Web. Students will use HTML/XHTML to create web pages with text in various sizes and colors, links to other sites, background color or patterns, graphics, tables, and mailto links. Principles of design and color as they apply to screen presentations will be included. This course has the option a letter grade or pass/no pass. May be repeated three times for credit. Also listed as CSIS 6 and DM 6. ADVISORY: CSIS 1 or CSIS 2 or CSIS/LIB 3 advised.

ONLINE:

You must have an email account to take the following two courses. Unless you have made prior arrangements with the instructor, you MUST log on by 11:59 pm on the first day of the course. Late adds must login within 24 hours of adding this course. If you miss the deadline you may be dropped. For help, contact your instructor or email disted@gavilan.edu.

	40827	Online	J Howel	2.0			Start by going to http://www.gavilan.edu/disted 02/07/11 - 03/25/11
	40829	Online	J Howel	2.0			Start by going to http://www.gavilan.edu/disted 03/28/11 - 05/27/11

MANAGEMENT

MGMT 102 Retail Management

Transferable: CSU

Principles and practices used in management of retail businesses such as foods, motels, service stations, and direct channels. Includes site selection, layout, organization, staffing, positioning, customer service, promotional techniques, and all aspects of the critical buying function. This course has the option of a letter grade or pass/no pass. ADVISORY: Eligible for English 250 and English 260.

40821	Lec	BU103	S Kurtz	3.3	3.0	M	0600-0905
-------	-----	-------	---------	-----	-----	---	-----------

MGMT 190 Occupational Work Experience/Management-Supervision

Transferable: CSU

Occupational work experience for students who have a job related to their major. A training plan is developed cooperatively between the employer, college and student. (P/NP grading) 75 hours per semester paid work = 1 unit. 60 hours non-paid (volunteer) work per semester = 1 unit. May be taken for a maximum total of 16 units. Minimum 2.00 GPA. REQUIRED: Declared vocational major.

Mandatory course orientation for the following classes will be conducted February 11: 2-3 pm, March 1: 4:30-5:30 pm, April 12: 12 pm. Meetings will be held in the Student Center-North/South Lounge. Students must attend one of the three meetings. www.gavilan.edu/cwe for assignments and details. Please contact Susan Sweeney, CWE Coordinator at ssweeney@gavilan.edu for more information.

40795	Wrk Ex	LI101A	S Sweeney	1.0			
40796	Wrk Ex	LI101A	S Sweeney	2.0			
40798	Wrk Ex	LI101A	S Sweeney	4.0			

CRN Type Room Instructor Hrs. Units Days Begin-End

MARKETING

MKTG 100 Principles of Marketing

Transferable: CSU

An introduction to the economic and social problems involved with moving goods and services from the producer to the consumer. This course covers topics such as marketing institutions, channels of distribution, pricing, and government relationships. This course has the option of a letter grade or pass/no pass. ADVISORY: Eligible for English 250 and English 260.

40584 Lec BU118 D McCormick 3.2 3.0 MW 1120-1240

MKTG 190 Occupational Work Experience/Marketing

Transferable: CSU

Occupational work experience for students who have a job related to their major. A training plan is developed cooperatively between the employer, college and student. (P/NP grading) 75 hours per semester paid work = 1 unit. 60 hours non-paid (volunteer) work per semester = 1 unit. May be taken for a maximum total of 16 units. Minimum 2.00 GPA. REQUIRED: Declared vocational major.

Mandatory course orientation for the following classes will be conducted February 11:2-3 pm, March 1: 4:30-5:30 pm, April 12: 12 pm. Meetings will be held in the Student Center-North/South Lounge. Students must attend one of the three meetings. www.gavilan.edu/cwe for assignments and details. Please contact Susan Sweeney, CWE Coordinator at ssweeney@gavilan.edu for more information.

40799	Wrk Ex	LI101A	S Sweeney	1.0
40800	Wrk Ex	LI101A	S Sweeney	2.0
40801	Wrk Ex	LI101A	S Sweeney	3.0
40802	Wrk Ex	LI101A	S Sweeney	4.0

MASS COMMUNICATIONS & TELEVISION

Mass Media: see also JOUR 10, Theatre Arts/Television

MCTV 16 Television History and Practice

Transferable: CSU

This course examines theories, history and development of television technology and current distribution practices. Programming genres and production techniques are analyzed, evaluated and compared with other societies as tools of mass communication. This course is also listed as THEA 16. ADVISORY: Eligible for English 250 and 260.

40651 Lec LI144 Abad 3.2 3.0 MW 1120-1240

MCTV 17A Television and Video Workshop

Transferable: CSU

An introduction to television and video technology, including pre-production, production and post-production techniques such as: camera work, studio equipment, lighting, audio plus off-line and on-line editing. This course is also listed as THEA 17A. ADVISORY: Theatre Arts 16 Intro to TV or consent of instructor.

40652 L/L LI144 J Frazier 5.4 3.0 TR 1250-0315

MCTV 17B Television and Video Workshop

Transferable: CSU

Emphasis placed on production and post-production techniques in video production. Student knowledge and skills are increased by participating in live to tape projects. May be repeated twice for credit. This course is also listed as THEA 17B. ADVISORY: Completion of Theatre Arts 17A.

40653 L/L LI144 J Frazier 5.4 3.0 TR 1250-0315

MCTV 19 Television and Film Acting

Transferable: CSU, UC; GAV-GE:C1

Theory and practice of acting for film and television. Students will learn basic performance techniques for the camera. Learning experiences include projects in broadcasting, reporting, commercials, public service announcements (PSA), comedy and drama. This course has the option of a letter grade or pass/no pass. May be repeated three times for credit. This course is also listed as THEA 19.

40858	L/L	LI144	J James R Gonzalez	3.2 3.0	TR	1120-1240
	ARR		TBA	3.2		



Retail Management



Associate's Degree and Certificate of Achievement

Jumpstart your career with Retail Management -- a specially recognized college program designed to prepare individuals for the fast-paced retail industry. The courses help students develop an understanding of the retail manager's job and the requirements for success in the retail environment.

The certificate is composed of ten courses which may be offered in a combination of face to face and distance learning formats.

To complete the Associate's Degree, students must also complete the general education requirements plus sufficient electives to meet a 60 unit total.

Topics include:

- Principles of Marketing
- Introduction to Supervision
- Techniques of Management
- Leadership/Human Relations in Business
- Human Resources Management
- Oral Communications
- Business Communications (written)
- Business Mathematics
- Bookkeeping and Accounting
- Survey of Microsoft Office Programs

Offered this semester:

- MGMT 102**
Retail Management
- MKTG 100**
Principles of Marketing

Questions?
Contact Sherrean Carr,
Dean of Career Technical
Education @ 408-848-4719
or scarr@gavilan.edu.



Work in print and online
Earn units toward a Media Arts Degree

Learn new writing, research and design skills
Get published and build a portfolio of your work
Gain work experience that will help you land a good job
Become part of a team
Support free speech at Gavilan College!

JOUR 10 Mass Media & Society

What impact do mass media have on our society and on our world?

JOUR 18A-D Working on the Newspaper

Become a staff member of The Gavilan Press, Gavilan's independent student newspaper, in print and online!

CRN Type Room Instructor Hrs. Units Days Begin-End

MATHEMATICS

Check out the Winter Math Boot Camp. Jan 18-20. Ad on pg. 69.

MATH 1A Single-Variable Calculus and Analytic Geometry

Transferable: CSU, UC; CSU-GE:B4, IGETC:2A; GAV-GE:B4; CAN:MATH18, MATH SEQ BC

Limits and continuity, analyzing the behavior and graphs of functions, derivatives, implicit differentiation, higher order derivatives, related rates and optimization word problems, Newton's Method, Fundamental Theorem of Calculus, and definite and indefinite integrals. **PREREQUISITE:** Mathematics 10 or Mathematics 8B with a grade of 'C' or better.

40330	Lec	MA103	D Kim	5.4	4.0	MW	0600-0825
-------	-----	-------	-------	-----	-----	----	-----------

MATH 1B Single-Variable Calculus and Analytic Geometry

Transferable: CSU, UC; CSU-GE:B4, IGETC:2A; GAV-GE:B4; CAN:MATH20, MATH SEQ BC

This course is a standard second semester Calculus course covering methods of integration, applications of the integral, differential equations, parametric and polar equations, and sequences and series. **PREREQUISITE:** Mathematics 1A with a grade of 'C' or better.

40331	Lec	MA103	K Wagman	4.8	4.0	MWF	1250-0210
-------	-----	-------	----------	-----	-----	-----	-----------

MATH 1C Multivariable Calculus

Transferable: CSU, UC; CSU-GE:B4, IGETC:2A; GAV-GE:B4; CAN:MATH22, MATH SEQ BC

A standard third semester Calculus course covering functions of several variables, vectors, surfaces, vector-valued functions, partial derivatives, multiple and line integrals, Green's Theorem, Stokes' Theorem, and the Divergence Theorem. **PREREQUISITE:** Mathematics 1B with a grade of 'C' or better.

40332	Lec	MA102	L Wolff	4.6	4.0	MW	0600-0805
-------	-----	-------	---------	-----	-----	----	-----------

MATH 5 Introduction to Statistics

Transferable: CSU, UC; CSU-GE:B4, IGETC:2A; GAV-GE:B4; CAN:STAT2

Descriptive analysis and presentation of either single-variable data or bivariate data, probability, probability distributions, normal probability distributions, sample variability, statistical inferences involving one and two populations, analysis of variance, linear correlation and regression analysis. Statistical computer software will be extensively integrated as a tool in the description and analysis of data. **PREREQUISITE:** Mathematics 233 with a grade of 'C' or better. The instructor will be using and supporting a TI-83 Plus graphing calculator in all classroom demonstrations.

40372	L/L	MA103	H Jukl	3.2	3.0	MW	0810-0930
	L/L	MA101	H Jukl	1.0	F		0810-0900
This service learning course section involves community work. See page 19 for more information.							
40373	L/L	MA103	J Nari	3.2	3.0	TR	1120-1240
	L/L	MA101	J Nari	1.0	F		1140-1230
40374	L/L	MA103	D Kim	2.3	3.0	M	0230-0435
	L/L	MA103	D Kim	1.3	W		0230-0335
	L/L	MA101	D Kim	1.0	W		0345-0435
40376	L/L	MHG12	A Viarengo	4.6	3.0	MW	0630-0835
Above class meets at Morgan Hill Community site.							
40377	L/L	HOL2	N Wadia	2.3	3.0	T	0700-0905
	L/L	HOL2	N Wadia	1.3	R		0700-0805
	L/L	HOL2	N Wadia	1.0	R		0825-0915
Above class meets at the Hollister Briggs site.							

 40375 Online R Knight 3.0 Start by going to <http://www.gavilan.edu/disted> You must have an email account to take this course. Unless you have made prior arrangements with the instructor, you MUST log on by 11:59 pm on the first day of the course. Late adds must login within 24 hours of adding this course. If you miss the deadline you may be dropped. For help, contact your instructor or email disted@gavilan.edu.

MATH 6 Calculus for Business/Social Science

Transferable: CSU, UC; CSU-GE:B4, IGETC:2A; GAV-GE:B4; CAN:MATH34

This course applies the fundamental principles and techniques of calculus to problems in business, economics, the life sciences and the social sciences. Topics will include limits, and differentiation and integration of linear, quadratic, polynomial, exponential and logarithmic functions. This course is not intended for students majoring in engineering, the physical sciences or math. Using a calculator is required. Graphing calculator is recommended. **PREREQUISITE:** Mathematics 233 with a grade of 'C' or better.

40378	Lec	MA102	L Lockhart	3.2	3.0	TR	0810-0930
-------	-----	-------	------------	-----	-----	----	-----------

CRN Type Room Instructor Hrs. Units Days Begin-End

MATH 7 Finite Mathematics

Transferable: CSU, UC; CSU-GE:B4, IGETC:2A; GAV-GE:B4; CAN:MATH12

Systems of linear equations and matrices, introduction to linear programming, finance, counting techniques and probability, properties of probability and applications of probability. **PREREQUISITE:** Mathematics 233 with a grade of 'C' or better.

40379	Lec	MA103	M Dresch	3.2	3.0	TR	1250-0210
-------	-----	-------	----------	-----	-----	----	-----------

MATH 8A First Half of Precalculus

Transferable: CSU, UC; CSU-GE:B4, IGETC:2A; GAV-GE:B4

Math 8A prepares the student for the study of calculus by providing important skills in algebraic manipulation, interpretation, and problem solving at the college level. Topics will include basic algebraic concepts, complex numbers, equations and inequalities of the first and second degree, functions, and graphs, linear and quadratic equations, polynomial functions, exponential and logarithmic functions, systems of equations, matrices and determinants, right triangle trigonometry, and the Law of Sines and Cosines. **PREREQUISITE:** Mathematics 233 with a grade of 'C' or better. The instructor will be using and supporting TI-83 Plus graphing calculator in all classroom demonstrations.

40380	Lec	PS102	D Lawson	2.8	4.0	MW	0945-1055
	Lec	PB7	D Lawson	1.4	F		0945-1055
40381	Lec	PS102	J Nari	4.6	4.0	MW	0600-0805

MATH 8B Second Half of Precalculus

Transferable: CSU, UC; CSU-GE:B4, IGETC:2A; GAV-GE:B4

Math 8B prepares students for the study of calculus by providing important skills in algebraic manipulation, interpretation, and problem solving at the college level. Topics will include trigonometric functions, identities, inverse trigonometric functions, and equations; applications of trigonometry, vectors, complex numbers, polar and parametric equations; conic sections; sequences, series, counting principles, permutations, mathematical induction; analytic geometry, and an introduction to limits. **PREREQUISITE:** Mathematics 8A with a grade of 'C' or better. **ADVISORY:** Math 208 Survey of Practical Geometry.

40382	Lec	PB7	A Furutani	4.2	4.0	TRF	1250-0200
-------	-----	-----	------------	-----	-----	-----	-----------

MATH 14 Math for the Liberal Arts

Transferable: CSU, UC; CSU-GE:B4, IGETC:2A; GAV-GE:B4

Survey of selected topics from contemporary mathematics to introduce the student to mathematical thinking for the non-specialist. Topics include systems of numeration, algebraic modeling, linear programming, trigonometry, math of finance, probability and statistics, and an introduction to calculus. **PREREQUISITE:** Math 233 with a grade of 'C' or better.

40329	Lec	PS105	A Washburn	3.3	3.0	M	0600-0905
-------	-----	-------	------------	-----	-----	---	-----------

MATH 205 Elementary Algebra

Transferable: No

This course is a standard beginning algebra course, including algebraic expressions, linear equations and inequalities in one variable, graphing, equations and inequalities in two variables, integer exponents, use of a scientific calculator, polynomials, rational expressions and equations, radicals and rational exponents, and quadratic equations. Mathematics 205, 205A and 205B, and 206 have similar course content. This course may not be taken by students who have completed Mathematics 205B or 206 with a grade of "C" or better. This course may be taken for Mathematics 205B credit (2.5 units) by those students who have successfully completed Mathematics 205A with a grade of "C" or better. **PREREQUISITE:** MATH 402 with a grade of 'Pass' or with a 'C' or better, or assessment test recommendation.

40333	Lec	PS102	G Fuller	2.0	5.0	MW	0810-0905
	Lec	MA103	G Fuller	3.0	TRF		0810-0905
40335	Lec	PB7	R Potter	2.6	5.0	MW	1120-1225
	Lec	LS101	R Potter	2.6	TR		1120-1225
40334	Lec	MHG10	S Kercheval	5.2	5.0	MTWR	1250-0155
Above class meets at Morgan Hill Community site.							
40336	Lec	HOL5	R Bates	5.2	5.0	MTWR	1250-0155
Above class meets at the Hollister Briggs site.							

The **ENGINEERING PROGRAM** is back! Classes begin in Fall 2011. Math 8A is a prerequisite for Physics 2A. Prepare by taking it now! See ad on page 77.

The **ENGINEERING PROGRAM** is back! Classes begin in Fall 2011. Math 8B is a prerequisite for Math 1A. Prepare by taking it now! See ad on page 77.

↳ continued

CRN Type Room Instructor Hrs. Units Days Begin-End

MATH 205 Continued

40337	Lec	PS102	R Lee	5.2	5.0	MTWR	1250-0155
40338	Lec	LS101	M Buchanan	5.4	5.0	MW	0600-0825
40339	Lec	MHG13	A Sioshansi	5.4	5.0	TR	0600-0825

Above class meets at Morgan Hill Community site.

MATH 205A First Half of Elementary Algebra

Transferable: No

This course is the first half of the Elementary Algebra course. It will cover signed numbers, evaluation of expressions, ratios and proportions, solving linear equations, and applications. Graphing of lines, the slope of a line, graphing linear equations, solving systems of equations, basic rules of exponents, and operations on polynomials will be covered. PREREQUISITE: Math 402 with a grade of 'Pass' or with a 'C' or better, or assessment test recommendation. ADVISORY: Concurrent enrollment in Guidance 563A is advised.

40340	Lec	HU104	R Potter	2.8	2.5	TR	1250-0200
	Lec	PS102	R Potter	1.4		F	1250-0200
40341	Lec	PB7	M Buchanan	4.2	2.5	MTW	0400-0510

MATH 205B Second Half of Elementary Algebra

Transferable: No

This course contains the material covered in the second half of the Elementary Algebra Course. It will cover factoring polynomials, solving quadratic equations by factoring, rational expressions, radicals, and solving quadratic equations. In addition, the course will review applications involving linear equations of one and two variables, finding slopes and graphing linear equations, solving systems of equations with two variables, and solving linear inequalities. Math 205, 205A and 205B, and 206 have similar course content. This course may not be taken by students who have completed Math 205 or 206 with a grade of 'C' or better. PREREQUISITE: Math 205A with a grade of 'C' or better. ADVISORY: Concurrent enrollment in Guidance 563B is advised.

40342	Lec	MA102	D Lawson	4.2	2.5	MWF	0810-0920
40343	Lec	PB7	L Lockhart	4.2	2.5	TRF	1120-1230
40344	Lec	PB7	A Arid	4.6	2.5	MW	0600-0805

MATH 233 Intermediate Algebra

Transferable: No; GAV-GE:B4

Review of basic concepts, linear equations and inequalities, graphs and functions, systems of linear equations, polynomials and polynomial functions, factoring, rational expressions and equations, roots, radicals, and complex numbers, solving quadratic equations, exponential and logarithmic functions, and problem solving strategies. Mathematics 233, 233A, and 233B have similar course content. This course may not be taken by students who have completed Mathematics 233B with a grade of 'C' or better. This course may be taken for Mathematics 233B credit (2.5) units by those students who have successfully completed Mathematics 233A with a grade of 'C' or better. PREREQUISITE: Mathematics 205 or Mathematics 205A and 205B or Mathematics 206 with a grade of 'C' or better. The instructor will be using and supporting TI-83 Plus graphing calculator in all classroom demonstrations.

The **ENGINEERING PROGRAM** is back! Classes begin in Fall 2011.

Math 233 is a prerequisite for Chemistry 1A and Math 8A. Prepare by taking it now! See ad on page 77.

40346	Lec	PB7	G Fuller	5.2	5.0	MTWR	0945-1050
40347	Lec	PS105	S Dharia	4.5	5.0	MWR	1120-1235
	Lec	PS105	S Dharia	.5		T	1120-1155
	Lec	PS105		1.0		T	1155-1245 *
	Lec	PB5		1.5		F	1120-1235 *

* Optional tutoring session

40349	Lec	PS105	E Dachkova	7.8	5.0	MTR	1250-0310
	Lec	MA102	E Dachkova	2.6		F	1250-0310

40348	Lec	HOL2	J Malokas	5.2	5.0	MTWR	1250-0155
-------	-----	------	-----------	-----	-----	------	-----------

Above class meets at the Hollister Briggs site.

40345	Lec	MHG12	S Ward	5.2	5.0	MTWR	1250-0155
-------	-----	-------	--------	-----	-----	------	-----------

Above class meets at Morgan Hill Community site.

40351	Lec	MA103	M Grover	5.4	5.0	TR	0600-0825
-------	-----	-------	----------	-----	-----	----	-----------

40350	Lec	HOL4	R Bates	5.4	5.0	TR	0600-0825
-------	-----	------	---------	-----	-----	----	-----------

Above class meets at the Hollister Briggs site.

Gavilan College Overview of Math Courses

Grade of "C" or better required in order to progress to the next course

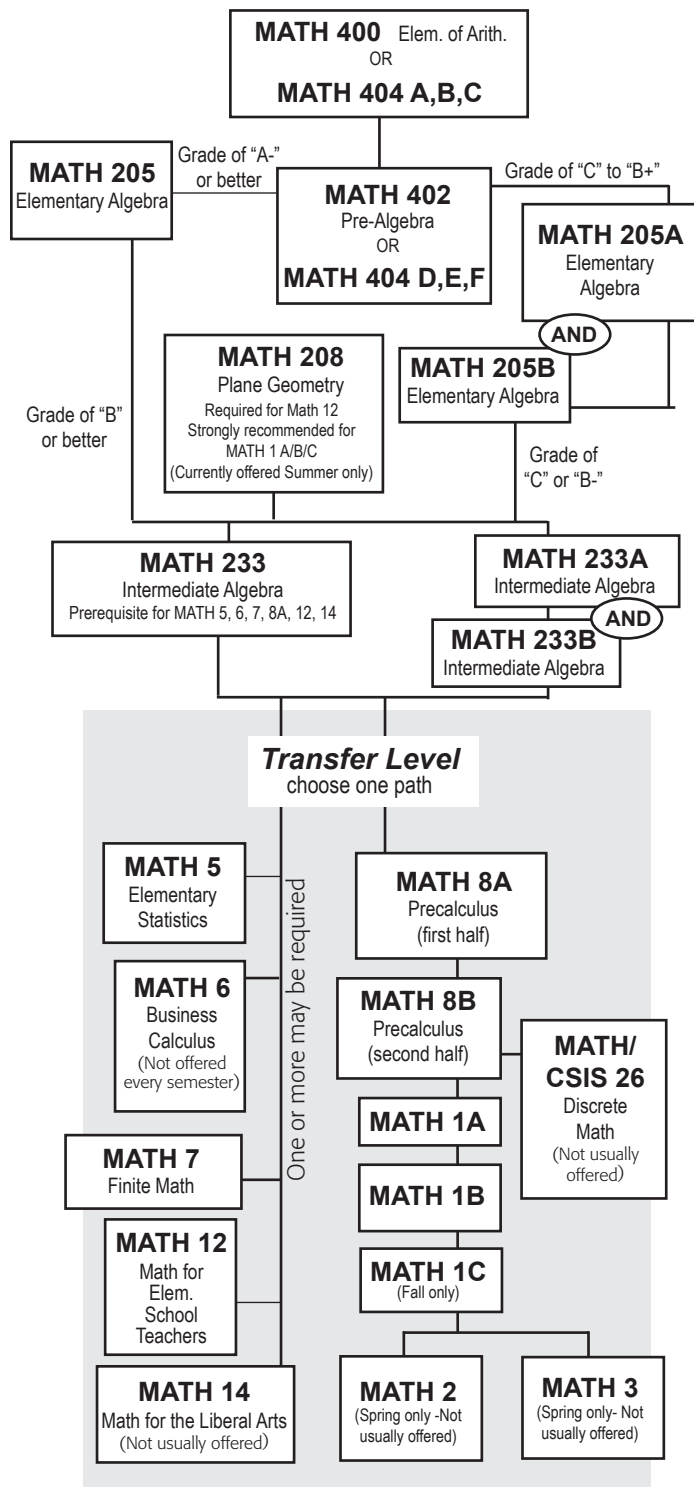

Multiple measures will be considered to determine your final course. Consult with a counselor to select the appropriate course.

CRN Type Room Instructor Hrs. Units Days Begin-End

MATH 233A First Half of Intermediate Algebra

Transferable: No

The course will start with a review of basic concepts and then cover the following topics with an emphasis on applications and problem solving strategies: solving linear and absolute value equations; solving linear and compound inequalities; equations and graphs of lines; functions and function notation including composition of functions; solving systems of linear equations and inequalities; operations with polynomials; factoring polynomials; and solving polynomial equations. PREREQUISITE: Completion of Mathematics 205 or the equivalent with a grade of 'C' or better.

40354	Lec	PS105	L Wills	2.8	2.5	TR	0945-1055
	Lec	MA102	L Wills	1.4		F	0945-1055
40352	Lec	LS102	M Dresch	4.2	2.5	TRF	1120-1230
40353	Lec	MA102	E Dachkova	2.8	2.5	TR	0400-0510
	Lec	MA102	E Dachkova	1.4		F	1120-1230

MATH 233B Second Half of Intermediate Algebra

Transferable: No; GAV-GE:B4

This course will start with a review factoring polynomials, and then cover the following topics with an emphasis on applications and problem solving strategies: solving polynomial equations by factoring; adding, subtracting, multiplying, dividing and simplifying rational expressions and solving rational equations; adding, subtracting, multiplying, dividing and simplifying roots, radicals and complex numbers and solving radical equations; working with composition of functions and inverse functions, working with exponential and logarithmic functions, equations and expressions; employing various methods of solving quadratic equations and inequalities; and graphing quadratic functions. PREREQUISITE: Completion of MATH 233A with a grade of 'C' or better.

40357	Lec	PS105	R Knight	4.2	2.5	TRF	0810-0920
40355	Lec	HU105	J Nari	4.2	2.5	MWF	1250-0210
40356	Lec	PS102	L Lockhart	4.6	2.5	TR	0600-0805

MATH 400 Elements of Arithmetic

Transferable: No

This course covers essential arithmetic operations, whole numbers, integers, fractions, decimals, ratio, proportion, percent, applications of arithmetic, and critical thinking, as well as math-specific study skills. This is a pass/no pass course, with pass being given for mastery of the content. Units earned in this course do not count toward the associate degree and/or other certain certificate requirements.

40358	L/L	LS102	S Dharia	4.2	3.0	TRF	0945-1055
40359	Lec	PB7	A Arid	4.6	3.0	TR	0600-0805

MATH 402 Pre-Algebra

Transferable: No

This course covers operations with integers, fractions and decimals and associated applications, percentages, ratio, and geometry and measurement, critical thinking and applications. Elementary algebra topics such as variables, expressions, and solving equations are introduced. This is a pass/no pass course where pass is given for mastery of the above topics. PREREQUISITE: Completion of Math 400 with a grade of 'Pass' or with a 'C' or better, or assessment test recommendation.

40360	L/L	PB7	D Wisneski	4.2	3.0	MWF	0810-0920
40361	L/L	MA103	J Nari	4.8	3.0	TRF	0945-1110
40362	L/L	LS101	M Dresch	3.4	3.0	TR	0945-1110
	L/L	PB5	M Dresch	1.7		F	0945-1110
40364	L/L	HOL4	J Malokas	3.2	3.0	TR	1120-1240
	L/L	HOL5	J Malokas	1.0		F	1210-0100

Above class meets at the Hollister Briggs site.

40363	L/L	MA102	L Robledo	4.6	3.0	TR	0600-0805
-------	-----	-------	-----------	-----	-----	----	-----------

CRN Type Room Instructor Hrs. Units Days Begin-End

MATH 404A-G Self-Paced Basic Math

Transferable: No

This course is a remedial, modular, self-paced course. Application and critical thinking skills are developed in each module. Module A covers operations with whole numbers, equivalent fractions, multiplying and dividing fractions. Module B covers adding and subtracting fractions, and operations with decimals. Module C covers ratio and proportion, percent, and units of measurement. Module D reviews fractions, decimals, percentages, and covers operations with integers, and working with variables. Module E covers real numbers, fractions, exponents, scientific notation, and order of operations. Module F covers expressions, polynomials, and equations. Module G covers geometric figures, perimeter and area, surface area and volume, triangles and parallelograms, and similar figures. This course has the option of a letter grade or pass/no pass. This course involves both lecture and hands-on computer assisted software. All sections are open for late registration. Math 404 A-C is the equivalent of Math 400.

These classes involve both lecture and hands-on computer components. All sections are open for late registration.

MATH 404A	40365	L/L	MA101	L Lockhart	5.6	1.0	TR	1250-0320
MATH 404B	40366	L/L	MA101	L Lockhart	5.6	1.0	TR	1250-0320
MATH 404C	40367	L/L	MA101	L Lockhart	5.6	1.0	TR	1250-0320
MATH 404D	40368	L/L	MA101	L Lockhart	5.6	1.0	TR	1250-0320
MATH 404E	40369	L/L	MA101	L Lockhart	5.6	1.0	TR	1250-0320
MATH 404F	40370	L/L	MA101	L Lockhart	5.6	1.0	TR	1250-0320
MATH 404G	40371	L/L	MA101	L Lockhart	5.6	1.0	TR	1250-0320

Medical Terminology: see Business Office Technology (BOT)

MUSIC

MUS 1B Music History and Literature

Transferable: CSU, UC; CSU-GE:C1, IGETC:3A; GAV-GE:C1

A survey of the development of music in western civilization including representative composers from the Medieval period to the present. Music 1B will study the music and styles from late Romanticism to the present. ADVISORY: Eligible for English 250 and English 260.

40666	Lec	MU101	N Vasallo	3.2	3.0	TR	0810-0930
-------	-----	-------	-----------	-----	-----	----	-----------

MUS 3A Harmony - Theory - Musicianship

Transferable: CSU, UC; CSU-GE:C1; GAV-GE:C1

Fundamentals of music, beginning harmony. ADVISORY: Must be taken in sequence.

40677	L/L	MU101	P Collins	4.6	4.0	MW	0900-1105
-------	-----	-------	-----------	-----	-----	----	-----------

MUS 4A Beginning Piano

Transferable: CSU, UC; CSU-GE:C1; GAV-GE:C1

Introduction to music fundamentals and keyboard technique. Development of beginning keyboard skills including note reading in bass and treble clef, fingering, rhythm, key signatures, primary chords and inversions. ADVISORY: Must be taken in sequence.

40678	L/L	MU102	M Amirkhanian	4.6	3.0	TR	0900-1105
40680	L/L	MU102	M Amirkhanian	4.6	3.0	MW	0900-1105
40679	L/L	MU102	M Amirkhanian	4.6	3.0	MW	1120-0125
40681	L/L	MU102	S Rathmell	4.3	3.0	M	0530-0935

Gavilan College
MATH LAB
MA101

FREE TUTORING!

Services for Gavilan Students:

Free Tutoring for MATH  Free Computer Assistance

For daily schedule or for free Math downloads, check our website - <http://www.gavilan.edu/math/mathlab/index.html>

CRN Type Room Instructor Hrs. Units Days Begin-End

MUS 4B Beginning Piano

Transferable: CSU, UC; GAV-GE:C1

Continuation of Music 4A. ADVISORY: Music 4A

40683	L/L	MU102	M Amirkhanian	3.2	2.0	TR	1120-1240
40682	L/L	MU102	S Rathmell	3.3	2.0	M	0630-0935

MUS 5A Intermediate Piano

Transferable: CSU, UC; GAV-GE:C1

Development of intermediate keyboard skills through means of scales, chords, and technical studies. Continuation of music fundamentals and beginning keyboard harmony; introduction of easier classical and standard piano literature. ADVISORY: Music 4B

40685	L/L	MU102	M Amirkhanian	3.2	2.0	TR	1120-1240
40684	L/L	MU102	S Rathmell	3.3	2.0	M	0630-0935

MUS 5B Intermediate Piano

Transferable: CSU, UC; GAV-GE:C1

Development of intermediate keyboard skills through means of scales, chords and technical studies. Continuation of music fundamentals and beginning keyboard harmony; introduction of easier classical and standard piano literature. ADVISORY: Music 5A

40687	L/L	MU102	M Amirkhanian	3.2	2.0	TR	1120-1240
40686	L/L	MU102	S Rathmell	3.3	2.0	M	0630-0935

MUS 5C Advanced Piano

Transferable: CSU, UC; GAV-GE:C1

Development of advanced keyboard skills through means of scales, chords and technical studies. Continuation of music fundamentals and keyboard harmony; introduction of moderately difficult classical and standard piano literature. ADVISORY: Music 5B

40691	L/L	MU102	M Amirkhanian	3.2	2.0	TR	1120-1240
40688	L/L	MU102	S Rathmell	3.3	2.0	M	0630-0935

MUS 5D Advanced Piano

Transferable: CSU, UC; GAV-GE:C1

Development of advanced keyboard skills through means of scales, chords and technical studies. Continuation of music fundamentals and keyboard harmony; introduction of moderately difficult classical and standard piano literature. ADVISORY: Music 5C

40693	L/L	MU102	M Amirkhanian	3.2	2.0	TR	1120-1240
40692	L/L	MU102	S Rathmell	3.3	2.0	M	0630-0935

MUS 6 Introduction to World Music

Transferable: CSU, UC; CSU-GE:C1, IGTC:3A; GAV-GE:C1

This course explores a broad and diverse survey of different non Western music cultures, helping students develop listening skills to identify, distinguish and appreciate the elements and richness of each culture's music. The course will cover a rich diversity of styles through informed listening, analysis and discernment of musical elements, form and repertoire. Music of various cultures will be explored, for example: India, China, Japan, the Middle East, Indonesia, Africa, Europe and the Americas.

40694	Lec	MU101	P Collins	3.2	3.0	MW	1120-1240
-------	-----	-------	-----------	-----	-----	----	-----------

MUS 8A Beginning Voice

Transferable: CSU, UC; GAV-GE:C1

Development of techniques in the art of singing and interpreting serious music in various styles. Study of the basic techniques of tone production, breathing and related skills. Basic repertoire development. ADVISORY: Continues in sequence or by demonstrated proficiency.

40695	L/L	MU101	N Pruitt	3.2	2.0	TR	1250-0210
-------	-----	-------	----------	-----	-----	----	-----------

MUS 8B Beginning Voice

Transferable: CSU, UC; GAV-GE:C1

Development of techniques in the art of singing and interpreting serious music in various styles. Study of the basic techniques of tone production, breathing and related skills. Basic repertoire development. ADVISORY: Music 8A or demonstrated proficiency.

40696	L/L	MU101	N Pruitt	3.2	2.0	TR	1250-0210
-------	-----	-------	----------	-----	-----	----	-----------

Winter MATH BOOT CAMP in January!

Get ready for your spring classes!

1/18-1/20
9 am - 3 pm

This three day – 6 hour a day, math seminar is designed for students who need to learn or to re-learn different algebraic structures and patterns. The students will gain insight on fundamental algebraic concepts and focus specifically on the algebraic structures related to standard algebraic terminology. Anyone who needs a review of basic math concepts such as fractions, decimals and percentage are also welcome.



This is an absolutely free fun winter math program. However, the space is limited to 25 people.

To save a space please email Elena Dachkova before 12/21/10. First 25 students will be registered. edachkova@gavilan.edu



Tutoring Center
www.gavilan.edu/tutor
408-848-4838
Located in LI 116



Free tutoring is available in a variety of subjects!

Work with a peer tutor and fellow students to develop a better understanding of course content.

Gary Cribb, Tutoring Program Coordinator
Kim Wilson, Tutoring Center Specialist

Fall/Spring Semester:
Mon-Thurs: 10 am - 3 pm

Summer Session: Call for hours

GRADUATION INFORMATION

Call 408-848-4737 for details about the graduation process.

The deadline for filling out a petition for graduation for spring is Monday, April 11, 2011.

Admissions & Records



CRN	Type	Room	Instructor	Hrs.	Units	Days	Begin-End
-----	------	------	------------	------	-------	------	-----------

MUS 8C Intermediate Voice

Transferable: CSU, UC; GAV-GE:C1

Development of techniques in the art of singing and interpreting serious music in various styles. Study of the basic techniques of tone production, breathing and related skills. Basic repertoire development. ADVISORY: Music 8B or demonstrated proficiency.

40697	L/L	MU101	N Pruitt	3.2	2.0	TR	1250-0210
-------	-----	-------	----------	-----	-----	----	-----------

MUS 8D Intermediate Voice

Transferable: CSU, UC; GAV-GE:C1

Development of techniques in the art of singing and interpreting serious music in various styles. Study of the basic techniques of tone production, breathing and related skills. Basic repertoire development. ADVISORY: Music 8C or demonstrated proficiency.

40698	L/L	MU101	N Pruitt	3.2	2.0	TR	1250-0210
-------	-----	-------	----------	-----	-----	----	-----------

MUS 9A Guitar

Transferable: CSU, UC; GAV-GE:C1

An introduction to playing the guitar. Basic staff notation, correct fingering and chord arpeggios are covered. Emphasis is also placed on developing musical listening skills. Students must provide their own guitars. May be repeated once for credit. ADVISORY: Students must provide their own guitars.

40700	Lab	AR103	T Montoya	3.3	1.0	M	0530-0835
-------	-----	-------	-----------	-----	-----	---	-----------

MUS 9B Guitar

Transferable: CSU, UC; GAV-GE:C1

An introduction to playing the guitar. Basic staff notation, correct fingering and chord arpeggios are covered. Emphasis is also placed on developing musical listening skills. Students must provide their own guitars. May be repeated once for credit. ADVISORY: Music 9A; students must provide their own guitars.

40701	Lab	AR103	T Montoya	3.3	1.0	M	0600-0905
-------	-----	-------	-----------	-----	-----	---	-----------

MUS 12 Vocal Ensemble

Transferable: CSU, UC; GAV-GE:C1

The day Vocal Ensemble will focus on individual and group performance of popular and alternative commercial music, and will rehearse and perform with a backup band. The evening Vocal Ensemble will study, rehearse and perform choral music in a broad spectrum of musical genre and styles. Included will be the study of vocal and rehearsal techniques as they relate to ensemble performance. Course may be repeated three times for credit.

40654	L/L	MU101	N Pruitt S Sotelo	3.3	2.0	M	1250-0355
-------	-----	-------	----------------------	-----	-----	---	-----------

40655	L/L	MU101	B Ruggles	3.3	2.0	T	0655-1000
-------	-----	-------	-----------	-----	-----	---	-----------

MUS 13 Concert Choir

Transferable: CSU, UC; GAV-GE:C1

The Concert Choir will study, rehearse and perform choral music from the 15th century to the present in a variety of musical styles with emphasis on the larger choral works and their preparation for public concert. Course may be repeated three times for credit. ADVISORY: Previous choral experience is preferred but not required. The student should have the ability to match a given pitch.

40656	L/L	MU101	B Ruggles	3.3	2.0	T	0655-1000
-------	-----	-------	-----------	-----	-----	---	-----------

MUS 14A Instrumental Ensemble

Transferable: CSU; GAV-GE:C1

Instruction for the experienced musician with emphasis on the study and performance of a wide variety of musical styles from Renaissance to 20th century music for traditional ensembles, and extensive consideration of contemporary commercial and alternative repertoire, and performance techniques for popular ensembles.

40657	L/L	MU101	N Pruitt S Sotelo	3.3	2.0	M	1250-0355
-------	-----	-------	----------------------	-----	-----	---	-----------

40658	L/L	SOLB7	A Quartuccio	3.3	2.0	W	0655-1000
Above class meets at Solorsano Middle School, 7121 Grenache Way, Gilroy.							

CRN	Type	Room	Instructor	Hrs.	Units	Days	Begin-End
-----	------	------	------------	------	-------	------	-----------

MUS 14B Instrumental Ensemble

Transferable: CSU; GAV-GE:C1

Instruction for the experienced musician with emphasis on the study and performance of a wide variety of musical styles from Renaissance to 20th century music for traditional ensembles, and extensive consideration of contemporary commercial and alternative repertoire, and performance techniques for popular ensembles.

40659	L/L	MU101	N Pruitt S Sotelo	3.3	2.0	M	1250-0355
-------	-----	-------	----------------------	-----	-----	---	-----------

40660	L/L	SOLB7	A Quartuccio	3.3	2.0	W	0655-1000
Above class meets at Solorsano Middle School, 7121 Grenache Way, Gilroy.							

MUS 14C Instrumental Ensemble

Transferable: CSU; GAV-GE:C1

Instruction for the experienced musician with emphasis on the study and performance of a wide variety of musical styles from Renaissance to 20th century music for traditional ensembles, and extensive consideration of contemporary commercial and alternative repertoire, and performance techniques for popular ensembles.

40661	L/L	MU101	N Pruitt S Sotelo	3.3	2.0	M	1250-0355
-------	-----	-------	----------------------	-----	-----	---	-----------

40662	L/L	SOLB7	A Quartuccio	3.3	2.0	W	0655-1000
Above class meets at Solorsano Middle School, 7121 Grenache Way, Gilroy.							

MUS 14D Instrumental Ensemble

Transferable: CSU; GAV-GE:C1

Instruction for the experienced musician with emphasis on the study and performance of a wide variety of musical styles from Renaissance to 20th century music for traditional ensembles, and extensive consideration of contemporary commercial and alternative repertoire, and performance techniques for popular ensembles.

40663	L/L	MU101	N Pruitt S Sotelo	3.3	2.0	M	1250-0355
-------	-----	-------	----------------------	-----	-----	---	-----------

40664	L/L	SOLB7	A Quartuccio	3.3	2.0	W	0655-1000
Above class meets at Solorsano Middle School, 7121 Grenache Way, Gilroy.							

MUS 16A Introduction to Audio Recording Techniques

Transferable: CSU

Survey of basic audio recording techniques and materials including acoustics, signal flow, block diagrams, cue systems, punch-ins, microphones and mic placement, frequency response, reverb, delay and outboard effects, stereo mixing, pre-mixing and actual recording. May be repeated once for credit.

40665	Lec	MU101	S Sotelo	3.3	3.0	W	1250-0355
-------	-----	-------	----------	-----	-----	---	-----------

MUS 21 Electronic Music/Sound Design

Transferable: CSU; GAV-GE:C1

Fundamentals of electronic music synthesis using computers. Midi sequencing, digital sound processing, sampling, digital multi-track recording utilizing the college's state of the art midi studio. May be repeated three times for credit. ADVISORY: Eligible for English 250, 260 and Mathematics 205.

40667	L/L	LI128	S Sotelo ARR	3.2 2.3	3.0	MW	0810-0930
-------	-----	-------	-----------------	------------	-----	----	-----------

MUS 22 Field Work and Service

Transferable: CSU

Supervised field work within the college and with local agencies. Students serve in useful group activities in leadership roles prescribed for them by faculty or community agencies. A maximum of six units may be completed. This is a pass/no pass course. REQUIRED: Learning contracts must be filled out and signed by the student and the supervising instructor.

40668	Fld Ex	MU101	A Quartuccio	1.0			
-------	--------	-------	--------------	-----	--	--	--

The Final Word!

Look for the Final Exams schedule on page 83.

CRN Type Room Instructor Hrs. Units Days Begin-End

MUS 23 Independent Study

Transferable: CSU

Designed to afford selected students specialized opportunities for exploring areas at the independent study level. The courses may involve extensive library work, research in the community, or special projects. May be repeated until six units of credit are accrued. This course has the option of a letter grade or pass/no pass. **REQUIRED:** The study outline prepared by the student and the instructor must be filed with the department and the dean.

40669	Ind	MU101	A Quartuccio	1.0
40670	Ind	MU101	N Pruitt	1.0
40671	Ind	MU101	N Pruitt	2.0
40672	Ind	MU105	M Amirkhanian	1.0
40673	Ind	MU105	M Amirkhanian	2.0
40674	Ind	AR103	T Montoya	1.0
40675	Ind	AR103	T Montoya	2.0

MUS 26 Symphony

Transferable: CSU, UC; GAV-GE:C1

Study and performance of orchestral literature. Individual and sectional skills development. Perform in public concerts each semester. May be repeated until a maximum of 8 units are accrued. **ADVISORY:** Demonstrated proficiency on individual's instrument and ability to read music.

40676	L/L	SOLB7	A Quartuccio	3,3	2,0	W	0655-1000
-------	-----	-------	--------------	-----	-----	---	-----------

Above class meets at Solarsano Middle School, 7121 Grenache Way, Gilroy.

MUS 98 Special Topics

Transferable: CSU; GAV-GE:C1

Special topics courses examine current problems or issues of interest to students within a specific discipline area. For topical content information, consult with appropriate department chairperson. For transfer status, check with a counselor. This course may have the option of a letter grade or pass/no pass.

40699	Lec	SOLB7	A Quartuccio	3,3	2,0	W	0655-1000
-------	-----	-------	--------------	-----	-----	---	-----------

Above class meets at Solarsano Middle School, 7121 Grenache Way, Gilroy.

MUS 190 Occupational Work Experience/Commercial Music

Transferable: CSU

Occupational work experience for students who have a job related to their major. A training plan is developed cooperatively between the employer, college and student. (P/NP grading) 75 hours per semester paid work = 1 unit. 60 hours non-paid (volunteer) work per semester = 1 unit. May be taken for a maximum total of 16 units. Minimum 2.00 GPA. **REQUIRED:** Declared vocational major.

Mandatory course orientation for the following classes will be conducted February 11: 2-3 pm, March 1: 4:30-5:30 pm, April 12: 12 pm. Meetings will be held in the Student Center-North/South Lounge. Students must attend one of the three meetings. www.gavilan.edu/cwe for assignments and details. Please contact Susan Sweeney, CWE Coordinator at ssweeney@gavilan.edu for more information.

40848	Wrk Ex	LI101A	S Sweeney	1.0
40850	Wrk Ex	LI101A	S Sweeney	3.0
40851	Wrk Ex	LI101A	S Sweeney	4.0

Nursing: see Allied Health

Nutrition: see Biological Sciences

Performing Arts: see Mass Communications & Television Theatre Arts (THEA)

Your educational plan:

You are expected to take the responsibility for scheduling an appointment with a counselor, preferably at least once a semester. The purpose of this appointment is to develop, review and update your educational plan to ensure that you are taking the appropriate courses to meet your educational goal.



The most fun you'll ever have in a class!

MUS 12 Vocal Ensemble

- Play:
- Rock & Roll
- Jazz
- Blues
- Top Hits
- Classics
- Your original songs!

MUS 14A Instrumental Ensemble

MUS 16A Introduction to Audio Recording Techniques



Protools Recording Studio

Back to Blues

March 5, 2011 Gavilan College Theater



Featuring:
the faculty of music department,
Gavilan College Ensemble, John Garcia,
the winner of the Marian Filice Piano
Competition and Watsonville Taiko

Theatre Arts Box Office: 408-846-4973
For more information go to www.gavilan.edu/music

Presented by Gavilan College in association with South Valley Symphony

CRN Type Room Instructor Hrs. Units Days Begin-End

PHILOSOPHY

PHIL 1 Introduction to Philosophy

Transferable: CSU, UC; CSU-GE:C2, IGETC:3B; GAV-GE:C2; CAN:PHIL2

Philosophy 1 is intended as a survey of the major areas and traditions of philosophy. The course examines central and significant questions about the meaning of life, who determines what is morally right or wrong, the ideal society, the various notions social justice, what is reality, and many other ideas. In pursuing these questions, students will be asked to read texts from writers around the world, both contemporary and ancient, discuss current events, and apply 'theory' to movies such as "The Matrix" trilogy, novels, and any other relevant application of the student's own choice. **ADVISORY:** Eligible for English 1A.

40702 Lec HOL2 E Hodge 3.2 3.0 TR 0230-0350
Above class meets at the Hollister Briggs site.

PHIL 2 Logic

Transferable: CSU, UC; CSU-GE:A3; GAV-GE:C2; CAN:PHIL6

Philosophy 2, Introduction to Logic, is intended as a survey of the primary approaches to argumentation and what has been traditionally called 'correct' reasoning. Learners will learn techniques of both deductive and inductive argumentation, how to spot a fallacy, as well as how to apply these techniques to other aspects of their lives outside the classroom. While logic is often quite formal, the goal is to see the practical application of this discipline. Additionally, learners will become acquainted with the cultural variations to reasoning in addition to the standard Western focal approach **ADVISORY:** Eligible for English 1A.

40704 Lec PB8 E Hodge 3.2 3.0 TR 1120-1240
40703 Lec AR103 M Johnston 3.3 3.0 W 0600-0905

PHIL 3B Contemporary Moral Issues

Transferable: CSU, UC; CSU-GE:C2, IGETC:3B; GAV-GE:C2, E2

Contemporary Moral Issues in an applied ethics class that covers major ethical theories and contemporary moral issues in a pluralistic manner. This course will cover such issues as abortion and euthanasia, cloning, experimentation on human subjects, capital punishment, race/ethnicity, sexual orientation and sexual morality, world hunger and poverty, colonialism and post-colonialism, and so forth. **ADVISORY:** Eligible for English 1A.

40706 Lec AR103 E Hodge 3.2 3.0 MW 1120-1240

PHIL 4 Critical Thinking and Writing

Transferable: CSU, UC; CSU-GE:A3, IGETC:1B; GAV-GE:C2

This course is designed to introduce the relationship between critical thinking and critical writing in a way that will be both enjoyable to the student and helpful in other aspects of life. The student will learn techniques of critical thinking, playing close attention to the current events, movies and popular media, music lyrics, as well as the textbook. Students will learn to identify deductive and inductive arguments and be able to evaluate their strength, create a strong argument of their own on a given topic, as well become experts in the area of critical analysis. The goal is to enable students to become strong, well informed, articulate members of the community as well as individuals with an empowered sense of self as an agent of change. **PREREQUISITE:** English 1A

40707 Lec AR103 E Hodge 3.2 3.0 MW 0945-1105
40708 Lec MHG11 G Grudzen 3.2 3.0 MW 0945-1105
Above class meets at Morgan Hill Community site.

PHIL 6 Comparative Religions

Transferable: CSU, UC; CSU-GE:C2, IGETC:3B; GAV-GE:C2, F

Religion is a topic that ignites controversy -- most societies engage in religious practices, believe strongly in that tradition, and find a sense of identity within it. The controversy arises when differences are misunderstood, misrepresented, or placed in a hierarchy of assumed supremacy of one religion as superior to others. In this class, students explore the underlying commonality of various religious traditions, explore the uniqueness of the religions with which they are unfamiliar, and learn to see that diversity among beliefs doesn't have to create hostility. Students will explore religions from Indigenous Peoples throughout the world, East Asia (e.g. India), China, the Middle East, as well as some more recent trends in religion. Previously known as PHIL 6A. **ADVISORY:** Eligible for English 1A.

 40709 Online E Hodge 3.0 Start by going to <http://www.gavilan.edu/disted> You must have an email account to take this course. Unless you have made prior arrangements with the instructor, you MUST log on by 11:59 pm on the first day of the course. Late adds must login within 24 hours of adding this course. If you miss the deadline you may be dropped. For help, contact your instructor or email disted@gavilan.edu.

CRN Type Room Instructor Hrs. Units Days Begin-End

PHIL 23 Independent Study

Transferable: CSU

Designed to afford selected students specialized opportunities for exploring areas at the independent study level. The courses may involve extensive library work, research in the community, or special projects. May be repeated until six units of credit are accrued. This course has the option of a letter grade or pass/no pass. **REQUIRED:** The study outline prepared by the student and the instructor must be filed with the department and the dean.

40705 Ind PB11 E Hodge 1.0

Photography: see Art, CSIS or Digital Media

PHYSICAL EDUCATION - ACADEMIC

Students should be aware that there are inherent risks involved in any physical exercise. Students are strongly advised to consult a physician prior to participating in any physical education activity.

PE 2 Introduction to Physical Education

Transferable: CSU, UC

This course is designed to examine the field of physical education from a historical and contemporary viewpoint. The broad spectrum of physical education as a discipline will be discussed. Goals and objectives of physical education as well as other career options will be introduced. This course has the option of a letter grade or pass/no pass. **ADVISORY:** Eligible for English 250 and English 260.

 40136 Online J Lango 3.0 Start by going to <http://www.gavilan.edu/disted> You must have an email account to take this course. Unless you have made prior arrangements with the instructor, you MUST log on by 11:59 pm on the first day of the course. Late adds must login within 24 hours of adding this course. If you miss the deadline you may be dropped. For help, contact your instructor or email disted@gavilan.edu.

PE 5 Individual and Dual Sports

Transferable: CSU, UC; GAV-GE:E1

Designed for those planning to work with children in the field of physical education or recreation. Activities such as badminton, bowling, golf, tennis, and archery may be covered. This course has the option of a letter grade or pass/no pass. **ADVISORY:** Eligible for English 250 and English 260.

40189 L/L GYGYM J Lango 3.2 3.0 TR 1120-1240
N Andrade

This class requires additional lab hours outside of the regular class meetings. See your instructor to schedule these hours.

PE 6 Games and Rhythms for Children

Transferable: CSU; GAV-GE:E1

Nature, function and organization of physical activities for the pre-school and elementary school age child. Emphasis is given to the understanding of psychomotor development and spatial awareness. Designed for those planning to work with children. Also listed as Child Development 6. This course has the option of a letter grade or pass/no pass. **ADVISORY:** Eligible for English 250 and English 260.

40199 Lec APE120 S Dodd 3.2 3.0 TR 0810-0930

PE 9A Fundamentals of Soccer

Transferable: CSU, UC; CSU-GE:E1; GAV-GE:E1

This course offers basic instruction in the theory, strategies, and techniques of soccer for the purpose of preparing the individual student in the fundamental aspects of playing and coaching the sport. May be repeated once for credit. This course has the option of a letter grade or pass/no pass.

40438 Lab GYGYM S STAFF 4.2 2.0 TR 0300-0445

PE 9B Fundamentals of Soccer

Transferable: CSU, UC; CSU-GE:E1; GAV-GE:E1

This course offers review and advanced instruction in the theory, strategies, and techniques of soccer for the purpose of preparing the individual student in all aspects of playing and coaching the sport. May be repeated once for credit. This course has the option of a letter grade or pass/no pass.

40441 Lab GYGYM S STAFF 3.8 2.0 TR 0300-0445

CRN Type Room Instructor Hrs. Units Days Begin-End

PE 13A Fundamentals of Volleyball

Transferable: CSU, UC; CSU-GE:E1; GAV-GE:E1

This course offers basic instruction in the theory, strategies, and techniques of volleyball for the purpose of preparing the student in the fundamental aspects of playing and coaching the game. May be repeated once for credit. This course has the option of a letter grade or pass/no pass.

40108 L/L GYGYM K Kramer 4.2 2.0 MW 1250-0235

PE 13B Fundamentals of Volleyball

Transferable: CSU; CSU-GE:E1; GAV-GE:E1

This course offers review and advanced instruction in the theory, strategies, and techniques of volleyball for the purpose of preparing the student in all aspects of playing and coaching the game. May be repeated once for credit. This course has the option of a letter grade or pass/no pass. ADVISORY: Physical Education 13A.

40111 L/L GYGYM K Kramer 3.8 2.0 MW 1250-0235

PHYSICAL EDUCATION - ACTIVITIES

PE Activities Classes can be taken for letter grade or pass/no pass.

PE 16 Swimming

Transferable: CSU, UC; CSU-GE:E1; GAV-GE:E1

Coeducational activity designed for all skill levels. The course teaches the techniques of a variety of strokes and includes conditioning activities. Instruction is tailored to meet individual and group needs. May be repeated three times for credit. This course has the option of a letter grade or pass/no pass.

40112 Lab GYPPOOL S Dodd 3.2 1.0 MW 1250-0210

PE 20 Bowling

Transferable: CSU, UC; CSU-GE:E1; GAV-GE:E1

Coeducational activity designed for beginning and intermediate bowlers; fundamentals and techniques of bowling. Scoring, bowling etiquette, terminology and team bowling are included. May be repeated three times for credit. This course has the option of a letter grade or pass/no pass.

40137 Lab GIBOWL J Lango 3.2 1.0 TR 0810-0930
Above class meets at Gilroy Bowl, 7554 Monterey Street, Gilroy, CA. A facility use fee of \$ 1.50 per session is required.

PE 23 Independent Study

Transferable: CSU

Designed to afford selected students specialized opportunities for exploring areas at the independent study level. The courses may involve extensive library work, research in the community, or special projects. May be repeated until six units of credit are accrued. This course has the option of a letter grade or pass/no pass. REQUIRED: The study outline prepared by the student and the instructor must be filed with the department and the dean.

40140 Ind GY116 S Dodd 2.0
This course is designed for Physical Education majors who have completed their course work and would like to do a semester-long written project.

PE 24 Individualized Weight Training

Transferable: CSU, UC; CSU-GE:E1; GAV-GE:E1

An open laboratory for those who desire an individualized strength program using exercise machines and free weights. May be repeated three times for credit. This course has the option of a letter grade or pass/no pass.

40141 Lab GYFITCNR S Dodd 14.0 1.0
Students should check in the first week of the semester at the Fitness Center (GY 123) during lab hours (MWF: 7 am - 2 pm, TuTh: 8 am - 2 pm, M-Th evenings: 4:30 - 6:30 pm).

40171 Lab GYFITCNR S Dodd 14.0 .5
Students should check in during the first week of the semester at the Fitness Center (GY 123) during lab hours (MWF: 7 am-2 pm, TuTh: 8 am-2 pm, M-Th: 4:30-6:30 pm).



Appropriate footwear is required in all gym facilities. No barefeet permitted.

GAVILAN COLLEGE BOOKSTORE

Student Center

408-848-4742

- NEW BOOKS
- USED BOOKS (25% LESS THAN NEW)
- BOOK BUY BACK

GET OUT OF LINE ● GET ON LINE

Order your textbooks @ www.gavilan.BKSTR.com

RETURN Policy Refunds given UP TO SEVEN DAYS from start of class. Always have your receipt. Always make sure new books have not been written in. Shrink wrap sets should be returned with all enclosures.

We accept all major credit cards and checks with ID

HOURS: Mon-Thurs, 8 am - 7 pm, Friday, 8 am - 4 pm



New!

Students can now save 50% or more by renting textbooks!

Go to rent-a-text.com or see store for details.

Faculty! Staff! Students! Working Parents! Community!



Looking for quality child care?

Call the Child Development Center at 408-848-4815 for more information.

License #430703716

FEE-BASED SERVICE
2-5 yrs 7 am - 6 pm

PART-DAY PROGRAM
Parents do not have to be students!

Gavilan's Child Development Center will accept payment from other subsidized programs (i.e., 4C's, Choices for Children) Personal payment also accepted.

Check out *Classes offered at the satellite sites...*

Hollister classes - pages 86-87

Morgan Hill classes - pages 88-89

CRN	Type	Room	Instructor	Hrs.	Units	Days	Begin-End
-----	------	------	------------	------	-------	------	-----------

PE 25 Soccer

Transferable: CSU, UC; CSU-GE:E1; GAV-GE:E1

Co-educational activity designed for all skill levels. Fundamentals, strategy and rules of the game are included. May be repeated three times for credit. This course has the option of a letter grade or pass/no pass.

40176 Lab GYGYM N Andrade 3.2 1.0 MW 0810-0930

PE 27 Basketball

Transferable: CSU, UC; CSU-GE:E1; GAV-GE:E1

Co-educational activity designed for all skill levels. Fundamentals, strategy and rules of the game are included. May be repeated three times for credit. This course has the option of a letter grade or pass/no pass.

40185 Lab GYGYM T Addison 4.0 .5 TR 0230-0430
04/05/11 - 05/28/11**PE 34, 35, 36, 38: see Physical Education: Adapted (APE)****PE 37 Softball**

Transferable: CSU, UC; CSU-GE:E1; GAV-GE:E1

Coeducational activity designed for all skill levels. Rules, fundamentals, and strategy and game play will be included. May be repeated three times for credit. This course has the option of a letter grade or pass/no pass.

40187 Lab GYGYM N Dequin 19.0 1.0 MTWRF 1000-0130
01/03/11 - 01/28/11**PE 46 Agility and Strength Development**

Transferable: CSU, UC; CSU-GE:E1; GAV-GE:E1

An activity class designed to improve and increase agility and strength development through various exercise and exercise programs. May be repeated three times for credit. This course has the option of a letter grade or pass/no pass.

40194 Lab GYGYM J Lango 4.0 1.0 MTWR 0310-0400

40200 Lab GYGYM J Lango 4.0 .5 MTWR 0310-0400
03/28/11 - 05/28/11**PE 61 Swim for Fitness**

Transferable: CSU, UC; CSU-GE:E1; GAV-GE:E1

Designed to develop endurance and swimming skills in order to maintain good cardiovascular/physical fitness. Intermediate swimming ability recommended. May be repeated three times for credit. This course has the option of a letter grade or pass/no pass.

40202 Lab GYPOOL S Dodd 3.2 .5 TR 0515-0635
03/28/11 - 05/28/11**PE 62 Yoga**

Transferable: CSU, UC; CSU-GE:E1; GAV-GE:E1

Coeducational activity designed for beginning and intermediate yoga students. A program designed to improve flexibility and reduce stress by learning a series of poses and focusing on proper breathing techniques. May be repeated three times for credit. This course has the option of a letter grade or pass/no pass.

40075 Lab MHG10 M Watson 3.2 1.0 MW 0500-0620
Above class meets at Morgan Hill Community site.

40204 Lab APE101 E Falvey 3.2 1.0 MW 1250-0210

40812 Lab PORTHL D Muscari 3.2 1.0 TR 0715-0835
Above class meets off-campus. Class Location: Portuguese Hall, 695 Seventh Street, Hollister, CA.

CRN	Type	Room	Instructor	Hrs.	Units	Days	Begin-End
-----	------	------	------------	------	-------	------	-----------

PE 64 Individualized Cardiovascular Fitness

Transferable: CSU, UC; CSU-GE:E1; GAV-GE:E1

A fitness program which develops cardiovascular endurance through an individualized open lab format. May be repeated three times for credit. This course has the option of a letter grade or pass/no pass.

40205 Lab GYFITNTR S Dodd 14.0 1.0
Students should check in during the first week of the semester at the Fitness Center (GY 123) during lab hours (MWF: 7 am-2 pm, TuTh: 8 am-2 pm, M-Th: 4:30-6:30 pm).40206 Lab GYFITNTR S Dodd 14.0 .5
Students should check in during the first week of the semester at the Fitness Center (GY 123) during lab hours (MWF: 7 am-2 pm, TuTh: 8 am-2 pm, M-Th: 4:30-6:30 pm).**PE 65 Baseball**

Transferable: CSU, UC; CSU-GE:E1; GAV-GE:E1

This course is designed for students of all skill levels who desire to learn the fundamentals, mechanics, strategy and rules of the game of baseball. May be repeated three times for credit. This course has the option of a letter grade or pass/no pass.

40207 Lab GYGYM N Andrade 19.0 1.0 MTWRF 0100-0430
01/03/11 - 01/28/11**PE 70 Pilates**

Transferable: CSU, UC; CSU-GE:E1; GAV-GE:E1

This class utilizes the Pilates exercise system focused on improving flexibility and strength for the total body through a series of controlled movements. May be repeated three times for credit. This course has the option of a letter grade or pass/no pass.

40425 Lab APE101 D Muscari 3.2 1.0 TR 1250-0210

PE 73 Fitness Through Dance

Transferable: CSU, UC; CSU-GE:E1; GAV-GE:E1

Conditioning the body through the use of various dances and/or dance steps. This course is designed to strengthen and tone the body, assist in weight loss, and increase endurance. May be repeated three times for credit. This course has the option of a letter grade or pass/no pass.

40427 Lab APE101 E Falvey 3.2 1.0 TR 1120-1240

PE 75 Sports Conditioning

Transferable: CSU, UC; CSU-GE:E1; GAV-GE:E1

This activity class is designed to improve the physical condition of our male and female student athletes. It includes strength training, cardiovascular endurance, plyometric training, and sport specific techniques through an open lab format. May be repeated three times for credit. This course has the option of a letter grade or pass/no pass.

40428 Lab GYFITNTR S Dodd 18.0 1.0
Students should check-in during the first week of the semester with their individual head coach. Work-out hours may vary by sport.40431 Lab GYFITNTR S Dodd 12.0 .5
Students should check in during the first week of the semester with their individual head coach. Work-out hours may vary by sport.**PE 79 Indoor Racket Sports**

Transferable: CSU, UC; CSU-GE:E; GAV-GE:E1

This coeducational class will include lessons in the net games of badminton, pickleball and table tennis. Instruction in the basic skills, rules, strategies, and application to game situations will be provided. May be repeated three times for credit. This course has the option of a letter grade or pass/no pass.

40115 Lab GYGYM K Kramer 3.0 1.0 F 1040-0135

PE 80 Ultimate Frisbee

Transferable: CSU, UC; CSU-GE:E; GAV-GE:E1

A coeducational activity designed for all skill levels. Includes instruction in throwing, catching, and the passing skills of ultimate frisbee. Team strategy, team play and the rules will be presented. Other disc activities, such as frisbee golf, may be included. May be repeated three times for credit. This course has the option of a letter grade or pass/no pass.

40432 Lab GYGYM K Kramer 3.2 1.0 TR 1250-0210

Don't be confused!

There are new codes
to designate days

R means Thursday!

U means Sunday!

CRN Type Room Instructor Hrs. Units Days Begin-End

PE 81 Kickboxing for Fitness

Transferable: CSU; CSU-GE:E

This course utilizes basic kickboxing techniques and physical conditioning in a cardio exercise program. May be repeated three times for credit. This course has the option of a letter grade or pass/no pass.

40433 Lab GYGYM N Dequin 3.2 1.0 MW 1120-1240

PHYSICAL EDUCATION - ADAPTED

APE 34 Adapted Aquatic Exercise

Transferable: CSU, UC; CSU-GE:E1; GAV-GE:E1

This course is designed to help individuals who by the nature of their disability such as wheelchair use, back injury, cardiovascular impairment, multiple sclerosis or other disabling condition require a specific aquatic exercise program that will contribute to their physical well-being. May be repeated as necessary based on measurable progress as documented in the student's educational contract. This course has the option of a letter grade or pass/no pass. Previously known as PE 34.

40215 Lab GYPOOL D Ellis 3.2 1.0 MW 0810-0930
 40217 Lab GYPOOL D Ellis 3.2 1.0 MW 1120-1240
 40219 Lab GYPOOL D Ellis/ K Sato 3.2 1.0 TR 1120-1240

APE 35 Adapted Swimming for Total Fitness

Transferable: CSU, UC; CSU-GE:E1; GAV-GE:E1

An individualized program of activities designed for students with physical disabilities to improve flexibility and range-of-motion, increase joint movement, improve circulation, and improve control of body movement through water adjustment and activities. Develops an appreciation of physical activity as a regular planned contribution to one's basic overall well-being. May be repeated as necessary based on measurable progress as documented in the student's educational contract. This course has the option of a letter grade or pass/no pass. Previously known as PE 35.

40221 Lab GYPOOL D Ellis 3.2 1.0 MW 0810-0930
 40222 Lab GYPOOL D Ellis 3.2 1.0 MW 1120-1240
 40223 Lab GYPOOL D Ellis/ K Sato 3.2 1.0 TR 1120-1240

APE 36 Adapted Physical Education

Transferable: CSU, UC; CSU-GE:E1; GAV-GE:E1

An individualized program of adaptive physical education activities designed to meet the needs of students with physical disabilities. Develops an appreciation of physical activity as a regular planned contribution to one's overall well-being. May be repeated as necessary based on measurable progress as documented in the student's educational contract. This course has the option of a letter grade or pass/no pass. Previously known as PE 36.

40226 Lab APE101 D Ellis 3.2 1.0 MW 0945-1105
 40227 Lab APE101 D Ellis 3.2 1.0 TR 0945-1105
 40228 Lab APE108 D Ellis 3.2 1.0 MW 1250-0210
 40229 Lab APE108 D Ellis 3.2 1.0 TR 1250-0210

APE 38 Adapted Cardiovascular Conditioning and Training

Transferable: CSU, UC; CSU-GE:E1; GAV-GE:E1

An individualized program of adapted exercises in weight training, stretching and cardiovascular conditioning for those individuals who have been disabled through stroke, cardiovascular accident, arthritis, multiple sclerosis, or other condition. May be repeated as necessary based on measurable progress as documented in the student's educational contract. This course has the option of a letter grade or pass/no pass. Previously known as PE 38.

40231 Lab APE101 D Ellis 3.2 1.0 MW 0945-1105
 40233 Lab APE101 D Ellis 3.2 1.0 TR 0945-1105
 40237 Lab APE108 D Ellis 3.2 1.0 MW 1250-0210
 40239 Lab APE108 D Ellis 3.2 1.0 TR 1250-0210

PE 534, 535, 536, 538: see Physical Education: Adapted (APE)

Spring Sports



Students wishing to participate in the intercollegiate athletic programs must be enrolled in and attending a minimum of 12 units during the first season of competition with a minimum of nine units applying towards a degree program.

For more information, contact the Athletic Department at 848-4876.

- Baseball
- Basketball
- Women's Softball

Also check out the following activity classes...

- Bowling
- Cardio Fitness
- Fitness Through Dance
- Individual Weight Training
- Indoor Racket Sports
- Kickboxing for Fitness
- Pilates
- Soccer
- Swim for Fitness
- Swimming
- Ultimate Frisbee
- Yoga



CRN Type Room Instructor Hrs. Units Days Begin-End

APE 534 Adapted Aquatic Exercise

Transferable: No

Designed to help individuals who by the nature of their disability such as wheelchair use, back injury, cardiovascular impairment, multiple sclerosis or other disabling condition require a specific aquatic exercise program that will contribute to their physical well being. May be repeated as necessary based on measurable progress as documented in the student's educational contract. This is a pass/no pass course. Previously known as PE 534.

40243 Lab GYPOOL D Ellis 3.2 1.0 MW 0810-0930
 40244 Lab GYPOOL D Ellis 3.2 1.0 MW 1120-1240
 40245 Lab GYPOOL D Ellis/ K Sato 3.2 1.0 TR 1120-1240

APE 535 Adapted Swimming for Total Fitness

Transferable: No

An individualized program of activities designed for students with physical disabilities to improve flexibility and range-of-motion, increase joint movement, improve circulation, and improve control over body movement through water adjustment and activities. Develops an appreciation of physical activity as a regular planned contribution to one's overall well-being. May be repeated as necessary based on measurable progress as documented in the student's educational contract. This course is pass/no pass. Previously known as PE 535.

40246 Lab GYPOOL D Ellis 3.2 1.0 MW 0810-0930
 40247 Lab GYPOOL D Ellis 3.2 1.0 MW 1120-1240
 40403 Lab GYPOOL D Ellis/ K Sato 3.2 1.0 TR 1120-1240

APE 536 Adapted Physical Education

Transferable: No

An individualized program of adaptive physical education activities designed to meet the needs of students with physical disabilities. Develops an appreciation of physical activity as a regular planned contribution to one's physical well-being. May be repeated as necessary based on measurable progress as documented in the student's educational contract. This is a pass/no pass course. Previously known as PE 536.

40404 Lab LOADCS1 K Sato 4.2 1.0 MWF 0945-1055
 Above class meets at Live Oak Adult Day Services, 651 West Sixth St., Gilroy.
 40405 Lab APE108 D Ellis 3.2 1.0 MW 0945-1105
 40406 Lab APE108 D Ellis 3.2 1.0 TR 0945-1105
 40407 Lab APE101 D Ellis 3.7 1.0 F 0945-1250
 Specialized class for students with developmental disabilities.
 40408 Lab APE108 D Ellis 3.2 1.0 MW 1250-0210
 40409 Lab APE108 D Ellis 3.2 1.0 TR 1250-0210

CRN Type Room Instructor Hrs. Units Days Begin-End

CRN Type Room Instructor Hrs. Units Days Begin-End

ONLINE CLASSES: Start by going to <http://www.gavilan.edu/disted>. You must have an email account to take an online course. Unless you have made prior arrangements with the instructor, you MUST log on by 11:59 pm on the first day of the course. Late adds must login within 24 hours of adding this course. If you miss the deadline you may be dropped. For help, contact your instructor or email disted@gavilan.edu.

APE 538 Adapted Cardiovascular Conditioning and Training

Transferable: No

An individualized program of adapted exercises in weight training, stretching and cardiovascular conditioning for those individuals who have been disabled through stroke, cardiovascular accident, arthritis, multiple sclerosis, or other condition. May be repeated as necessary based on measurable progress as documented in the student's educational contract. This is a pass/no pass course. Previously known as PE 538.

40411	Lab	APE108	D Ellis	3.2	1.0	MW	0945-1105
40413	Lab	APE108	D Ellis	3.2	1.0	TR	0945-1105
40414	Lab	LOADCS1	J Maringer	3.2	1.0	TR	0945-1105
Above class meets at Live Oak Adult Day Services, 651 West Sixth St., Gilroy.							
40412	Lab	APE108	D Ellis	3.2	1.0	MW	1250-0210
40415	Lab	APE108	D Ellis	3.2	1.0	TR	1250-0210

INTERCOLLEGIATE ATHLETICS

ATH 35 Intercollegiate Basketball

Transferable: CSU, UC; CSU-GE:E1; GAV-GE:E1

This course provides practice and competition in intercollegiate basketball. Before participating, students must have completed a physical exam and their athletic eligibility paperwork. May be repeated three times for credit. This course has the option of a letter grade or pass/no pass.

40077	Lab	GYGYM	T Addison	10.0	1.0	MTWRF	0230-0430
02/02/11 - 03/25/11							

ATH 38 Intercollegiate Baseball

Transferable: CSU, UC; CSU-GE:E1; GAV-GE:E1

This course provides practice and competition in intercollegiate baseball for men. Before participating, students must have completed a physical exam and their athletic eligibility paperwork. May be repeated three times for credit. This course has the option of a letter grade or pass/no pass.

40078	Lab	ATHFLDBAS	N Andrade	10.0	2.0	MTWRF	0230-0430
-------	-----	-----------	-----------	------	-----	-------	-----------

ATH 45 Intercollegiate Softball

Transferable: CSU, UC; CSU-GE:E1; GAV-GE:E1

This course provides practice and competition in intercollegiate softball for women. Before participating, students must have completed a physical exam and their athletic eligibility paperwork. May be repeated three times for credit. This course has the option of a letter grade or pass/no pass.

40080	Lab	ATHFLDSFT	N Dequin	10.0	2.0	MTWRF	0230-0430
-------	-----	-----------	----------	------	-----	-------	-----------

MATH • ENGINEERING • SCIENCE MAJORS
PLANNING TO TRANSFER?
Admission for these majors is very competitive



Are you a math based major? (BIO, CSIS, Architecture, etc.) ♦ Do you want to transfer to a 4-year university? ♦ Do you have financial need? You may be eligible.

Gavilan's MESA Program is now accepting applications. MESA students are entitled to work-shops, academic advising, transfer assistance, campus visits, facilitator and instructor led study groups and more! For more information call 408-848-4887 or visit the MESA Study Center in MA115.

- ♦ www.gavilan.edu/MESA ♦
- ♦ High-unit majors do not need to fulfill all general education requirements before transfer.
- ♦ You may be eligible for an AA or AS degree before transfer.
- ♦ You should plan your sequential courses early.
- ♦ You may be qualified to sign a Transfer Admissions Agreement with UC or CSU.

PHYSICAL SCIENCE

PSCI 1 Principles of Physical Science

Transferable: CSU, UC; CSU-GE:B1, IGETC:5A; GAV-GE:B1

An introduction to the physical sciences for the non-science major. Attention is focused on fundamental laws of nature, their development and relation to the physical world. ADVISORY: Mathematics 205 and eligible for English 250 and 260.

40468	Lec	HOL4	A Van Tuyl	3.3	3.0	M	0630-0935
Above class meets at the Hollister Briggs site.							

PSCI 2 Introduction to Meteorology

Transferable: CSU, UC; CSU-GE:B1, IGETC:5A; GAV-GE:B1

An introductory course in Meteorology that is both descriptive and analytical on the physical principles affecting the earth's weather. Topics covered include the nature of the atmosphere, solar energy, heat, temperature, pressure, stability, moisture, wind, storms, severe weather and forecasting. The course introduces climatology as a scientific study and will look at the earth's climatic history, current research in climate modeling and the possibility of global climate change. ADVISORY: MATH 205.

40469	Online		A Van Tuyl	3.0			See information above about online classes.
-------	--------	--	------------	-----	--	--	---

PHYSICS

PHYS 1 Introduction to Physics

Transferable: CSU, UC; CSU-GE:B1, B3, IGETC:5A; GAV-GE:B1, B3

This course is an introduction to the fundamental physical principles that control the world around us. Students will explore the fundamental principles of physics, their historical development, their application to everyday phenomena, and their impact upon political, social, and environmental issues. Laboratory exercises will explore the everyday world. ADVISORY: Mathematics 205.

40465	L/L	PS102	R Lee	6.5	4.0	TR	0945-1249
-------	-----	-------	-------	-----	-----	----	-----------

PHYS 2B General Physics

Transferable: CSU, UC; CSU-GE:B1, B3, IGETC:5A; GAV-GE:B1, B3; CAN:PHYS4, PHYS SEQ A

An introduction to the principles of physics using algebra and trigonometry. Topics include electricity and magnetism, light and optics, modern physics, and an introduction to relativity. PREREQUISITE: Physics 2A ADVISORY: Eligible for English 250 and English 260

40466	L/L	PS102	R Lee	3.2	4.0	MW	1120-1240
	L/L	PS102	R Lee	2.3		W	0230-0435
	L/L	PS102	R Lee	1.0		F	1140-1230

PHYS 4A Physics for Scientists and Engineers - Mechanics/ Fluids/Wave

Transferable: CSU, UC; CSU-GE:B1, B3, IGETC:5A; GAV-GE:B1, B3; CAN:

An introduction to the principles of physics using calculus. Topics include kinematics in one, two and three dimensions, vectors, equilibrium and non-equilibrium applications of Newton's Laws, work and energy, momentum, systems of particles, rotational kinematics and dynamics, simple harmonic motion, elasticity, and waves. PREREQUISITE: Physics 2A and Mathematics 1A ADVISORY: Eligible for English 250 and English 260.

40467	L/L	PS102	R Lee	6.9	4.0	MTR	0210-0415
-------	-----	-------	-------	-----	-----	-----	-----------

CRN Type Room Instructor Hrs. Units Days Begin-End

Physiology: see Biological Sciences

POLITICAL SCIENCE

POLS 1 Introduction to American Government

Transferable: CSU, UC; CSU-GE:D8, IGETC:4H, 7A; GAV-GE:D1, D2; CAN:GOVT2
 Explores the development of American political institutions and their utilization in dealing with issues arising at the international, national and state levels. Emphasis is placed on those problems which have defined our federal system of government. California government and appropriate state institutions will be included as a vital part of our federal system of government. **ADVISORY:** Eligible for English 250 and English 260.

40298	Lec	PB3	M Turetzky	3.2	3.0	MW	0810-0930
40299	Lec	PB3	M Turetzky	3.2	3.0	TR	0810-0930
40300	Lec	MHG10	S Banks	3.2	3.0	MW	1120-1240
Above class meets at Morgan Hill Community site.							
40302	Lec	HOL1	S Pinnell	3.2	3.0	TR	0230-0350
Above class meets at the Hollister Briggs site.							

 40301 Online M Turetzky 3.0 See info on page 76 about online classes.

POLS 3 Introduction to Comparative Politics

Transferable: CSU, UC; CSU-GE:D8, IGETC:4H; GAV-GE:D2, F
 Comparative survey of political institutions and processes around the globe. Selected nations may include, but are not restricted to: the United Kingdom, France, Germany, Japan, Russia, India, Nigeria, and Mexico. **ADVISORY:** Eligible for English 250 and English 260.

40305	Lec	LI171	M Turetzky	3.2	3.0	MW	1120-1240
-------	-----	-------	------------	-----	-----	----	-----------

 **POLS 5 Introduction to Modern International Terrorism**

Transferable: CSU, UC
 This course centers on conceptually defining terrorism (all types-foreign and domestic, left and right wing, religious, environmental, and political, state and non-state), tracing the history and beginnings of modern international and domestic terrorism, critically examining the various U.S.-global responses to the 9-11-01 attacks, as well as generally evaluating and assessing how countries and peoples around the world try to cope with, prevent and/or respond to attacks by terrorist organizations, groups, or acts of terrorism perpetrated by nation-states or groups working with nation-states. This class is also listed as AJ 5. This course may be taken for a letter grade or pass/no pass.

40306	Lec	PB3	M Turetzky	3.3	3.0	T	0600-0905
-------	-----	-----	------------	-----	-----	---	-----------

POLS 6 Introduction to Conflict Resolution

Transferable: CSU; CSU-GE:D7; GAV-GE:D2
 Introduction to Conflict Resolution introduces students to conflict resolution and mediation. Integrating theory and practice, students will assess core concepts about the causes and resolution of conflict, and will practice communication skills for conflict resolution. Students will examine how ethnicity, gender, and class affect power in conflict situations. They will be able to formulate appropriate conflict resolution strategies, and will develop and practice various basic co-mediation skills. This course has the option of a letter grade or pass/no pass. This course is also listed as AJ 6 and PSYC 6 and CMUN 6. **ADVISORY:** English 250 and English 260.

40307	Lec	PB8	L Halper	3.2	3.0	MW	1120-1240
This service learning course section involves community work. See page 19 for more information.							

POLS 23 Independent Study

Transferable: CSU
 Designed to afford selected students specialized opportunities for exploring areas at the independent study level. The courses may involve extensive library work, research in the community, or special projects. May be repeated until six units of credit are accrued. This course has the option of a letter grade or pass/no pass. **REQUIRED:** The study outline prepared by the student and the instructor must be filed with the department and the dean.

40303	Ind	BU	M Turetzky	1.0			
40304	Ind	BU	M Turetzky	2.0			

ENGINEERING IS BACK!

Gavilan College will again offer a comprehensive lower-division engineering program beginning in the fall semester of 2011.

The program will prepare students for transfer with full junior standing to four-year engineering colleges. Gavilan's program follows a pattern established by the California Engineering Liaison Committee (ELC), an organization composed of representatives from all the two- and four- year engineering colleges in the state. Students will be able to transfer to the campus of their choice and complete the required program in the same time period as students who start at the four-year schools.

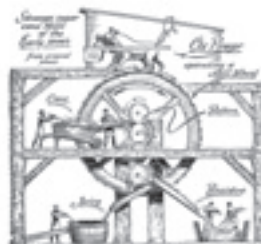

For information about the Engineering Program, the course offerings, and your personal path to transferring to a four-year engineering school, please contact your counselor or the engineering instructor, Russell Lee, at 408-848-4881 or rlee@gavilan.edu. We look forward to seeing you in our engineering classes soon!

New Social Science Degrees

two areas of emphasis:

With a social science background you can transfer successfully to a four-year college, pursue fascinating professions, and make meaningful contributions to a changing world.

Global Studies AA Degree



Find travel, adventure, and connection across boundaries. Gain durable tools to promote social justice.

Courses include:

anthropology, cultural geography, economics, history, political science, psychology, and sociology. You'll have an exciting study abroad option and you'll begin to prepare for a variety of careers in fields such as public service, policy, law, international relations, international business, health, politics, environmental policy, media, anthropology, history, economics, urban planning, political science, and more.

Community Studies AA Degree



Make a difference! Develop cultural competence and the skills to negotiate cultural boundaries, embrace differences and address issues of common concern.

Serve with community leaders at local agencies. Become a part of important movements for social justice and change and develop attributes every employer seeks, while honing critical thinking and writing skills that will serve you well in academia and in life.

Enter the fields of public service, law, politics, community organizing, advocacy, media, teaching, social work, psychology, health, anthropology, history, urban planning, economics, and more.

For more information on these two new degrees contact:
www.gavilan.edu/social_sciences/index.html
 Counseling: (408) 848-4723
 Liberal Arts & Sciences: (408) 848-4702

CRN Type Room Instructor Hrs. Units Days Begin-End

 **ONLINE CLASSES:** Start by going to <http://www.gavilan.edu/disted>. You must have an email account to take an online course. Unless you have made prior arrangements with the instructor, you MUST log on by 11:59 pm on the first day of the course. Late adds must login within 24 hours of adding this course. If you miss the deadline you may be dropped. For help, contact your instructor or email disted@gavilan.edu.

POLS 27 Contemporary Leadership

Transferable: CSU; GAV-GE:E2

A cross-disciplinary approach to the theory and practice of leadership. Includes effective communication styles including issues related to gender and culture. Class includes topics on ethics, power, and how to run effective meetings including the use of parliamentary procedure. Skills directly applicable to work, personal and college environments. May be repeated for a maximum of 10 units. Also listed as PSYC 27. ADVISORY: Eligible for English 250 and English 260.

40195 L/L SC154N J Stewart 3.2 2.0 TR 0945-1105

PSYCHOLOGY

PSYC 1A Introduction to Psychology

Transferable: CSU, UC; CSU-GE:D9, IGETC:4I; GAV-GE:D2; CAN:PSY2

The nature, scope, methods, presuppositions, history, and fields of psychology together with the scientific study of factors influencing human behavior, human development, perception, learning, memory, emotion, personality, frustration, and psychotherapy. ADVISORY: Eligible for English 250 and English 260.

40308 Lec PB5 C Oler 3.2 3.0 MW 0810-0930

40309 Lec PB3 J Campilli 3.2 3.0 TR 0945-1105

40310 Lec HOL1 C Oler 3.2 3.0 TR 1120-1240
Above class meets at the Hollister Briggs site.

40311 Lec PB5 C Oler 3.2 3.0 MW 1250-0210

40312 Lec MHG10 C Oler 3.3 3.0 R 0600-0905
Above class meets at Morgan Hill Community site.

PSYC 1B Introduction to Psychology

Transferable: CSU, UC; CSU-GE:D9, IGETC:4I; GAV-GE:D2

Continuation of Psychology 1A. This course stresses the biological basis of behavior including: neuroanatomy, the senses, perception, learning, thinking, and psychological disorders. PREREQUISITE: Completion of Psychology 1A with a grade of 'C' or better.

40314 Lec PB5 C Oler 3.2 3.0 MW 0945-1105

PSYC 2 Early Child Development

Transferable: CSU, UC; CSU-GE:D9, E, IGETC:4I; GAV-GE:D2

This course examines typical and atypical development within the psychosocial, cognitive, and physical domains from conception through the preschool years. Upon completion of this course, students will be able to evaluate theories and research of child development and effectively apply and communicate their understanding through observation and evaluation. This course is also listed as CD 2. This course has the option of a letter grade or pass/no pass. ADVISORY: Eligible for English 1A; transfer student consult with advisor.

 40091 Online M Bumgarner 3.0 See information above about online classes.

40093 Lec MHG4 M Bumgarner 3.2 3.0 MW 0945-1105
Above class meets at Morgan Hill Community site.

40139 Lec GHS-B1 D Muscari 3.0 3.0 T 0330-0630
This class is part of the High Step Program. It will be offered at Gilroy High School, Room B1. This class is open to all students. For more information, see a Gavilan counselor.

CRN Type Room Instructor Hrs. Units Days Begin-End

PSYC 3 Child Growth and Development During the School Years

Transferable: CSU, UC; CSU-GE:D9, E, IGETC:4I; GAV-GE:D2

This course examines typical and atypical development within the psychosocial, cognitive and physical domains from middle childhood through adolescence. Upon completion of this course, students will be able to evaluate theories and research of child development and effectively apply and communicate their understanding through observation and evaluation. This course has the option of a letter grade or pass/no pass. This course is also listed as CD 3. ADVISORY: Eligible for English 1A; transfer students consult with advisor.

40398 Lec MHG4 M Bumgarner 3.4 3.0 MW 1120-1245
Above class meets at Morgan Hill Community site.

40144 Lec CHS-B101 J Weiler 3.0 3.0 R 0330-0630
This class is part of the High Step Program. It will be offered at Christopher High School, Room B101. This class is open to all students. For more information, see a Gavilan Counselor.

40397 Lec HOL2 R Brown 3.3 3.0 W 0600-0905
Above class meets at the Hollister Briggs site.

PSYC 5 Self-Assessment and Career Development

Transferable: CSU; CSU-GE:E2; GAV-GE:E2

A course designed to assist the student in learning more about personal values, personality, interests, exploration of career choice, and occupational opportunities through the use of various personal assessment instruments. The delivery options for this course include online and self-paced formats. This course is also listed as GUID 1. ADVISORY: Eligible for English 250 and English 260. \$12 fee will be charged for career assessment materials.

40167 Lec HU105 J Godley 3.2 3.0 TR 1250-0210

 40169 Online L Tenney 3.0 See information above about online classes.

PSYC 6 Introduction to Conflict Resolution

Transferable: CSU; CSU-GE:D7; GAV-GE:D2

Introduction to Conflict Resolution introduces students to conflict resolution and mediation. Integrating theory and practice, students will assess core concepts about the causes and resolution of conflict, and will practice communication skills for conflict resolution. Students will examine how ethnicity, gender, and class affect power in conflict situations. They will be able to formulate appropriate conflict resolution strategies, and will develop and practice various basic co-mediation skills. This course has the option of a letter grade or pass/no pass. This course is also listed as AJ 6 and POLS 6 and CMUN 6. ADVISORY: English 250 and English 260.

40317 Lec PB8 L Halper 3.2 3.0 MW 1120-1240

This service learning course section involves community work. See page 19 for more information.

PSYC 22 Field Work and Service

Transferable: CSU

Supervised field work within the college and with local agencies. Students serve in useful group activities in leadership roles prescribed for them by faculty or community agencies. A maximum of six units may be completed. This is a pass/no pass course. REQUIRED: Learning contracts must be filled out and signed by the student and the supervising instructor.

40315 Fld Ex PB11 C Oler 1.0

PSYC 23 Independent Study

Transferable: CSU

Designed to afford selected students specialized opportunities for exploring areas at the independent study level. The courses may involve extensive library work, research in the community, or special projects. May be repeated until six units of credit are accrued. This course has the option of a letter grade or pass/no pass. REQUIRED: The study outline prepared by the student and the instructor must be filed with the department and the dean.

40316 Ind PB11 C Oler 2.0

PSYC 27 Contemporary Leadership

Transferable: CSU; GAV-GE:E2

A cross-disciplinary approach to the theory and practice of leadership. Includes effective communication styles including issues related to gender and culture. Class includes topics on ethics, power, and how to run effective meetings including the use of parliamentary procedure. Skills directly applicable to work, personal and college environments. May be repeated for a maximum of 10 units. Also listed as POLS 27. ADVISORY: Eligible for English 250 and English 260.

40198 L/L SC154S J Stewart 3.2 2.0 TR 0945-1105

Don't forget

A counselor's signature is required if you take 18 or more units (spring/fall) or 6 or more (summer).

You do not need a counselor's signature to register for a class with a prerequisite that was successfully completed at Gavilan.

CRN Type Room Instructor Hrs. Units Days Begin-End

Public Speaking: see Communication Studies
Skin Care: see COS 220, 221

SOCIOLOGY

SOC 1A Introduction to Sociology

Transferable: CSU, UC; CSU-GE:D0, IGETC:4J; GAV-GE:D2; CAN:SOC2

Analysis of the structure and dynamics of human society focusing on the development of culture, the socialization process, group behavior, social inequality, deviance, sexism, racism, and ageism, major social institutions, and human ecology. Emphasizes contemporary American society. **ADVISORY:** Eligible for English 250 and English 260.

40320 Lec MHG13 R Kreider 3.2 3.0 TR 0945-1105
 Above class meets at Morgan Hill Community site.

40319 Lec HOL6 E Cervantes 3.3 3.0 M 0600-0905
 Above class meets at the Hollister Briggs site.

40321 Lec PB13 R Kreider 3.2 3.0 MW 1250-0210

40322 Online R Kreider 3.0 See info on page 78 about online classes.

SOC 1B Introduction to Sociology: Social Problems

Transferable: CSU, UC; CSU-GE:D0, IGETC:4J; GAV-GE:D2; CAN:SOC4

This course provides an overview of how sociologists understand, identify, and address social problems. Students will be introduced to and critically evaluate various theories to explain and analyze social problems, their presence in our lives, and the extent to which they can be defined as social problems. In addition to identifying contemporary social problems, students will explore the root causes of these social problems and search for potential solutions. Some issues that may be examined are: economic globalization, immigration, poverty, inequalities in educational and employment opportunities, race and gender inequality, and the decline in social connections. **ADVISORY:** Sociology 1A.

40323 Lec PB3 L Padilla 3.2 3.0 MW 1120-1240
 This service learning course section involves community work. See page 19 for more information.

SOC 3 Sociology of Race, Ethnicity and Cultural Identity

Transferable: CSU, UC; CSU-GE:D0, D3, IGETC:4J; GAV-GE:D2, F

This course is designed to introduce students to the basic sociological concepts and theories of race, ethnicity and cultural identity in U.S. society. Students will examine race, ethnicity and cultural identity as social constructs that permeate social structures and institutions, and how they change over time and space. Over the semester students will critically analyze the ways which race, ethnicity, class, and gender/sexuality continually shape people's lives and experiences. While the class focuses on U.S. societies, students will also critically compare and contrast race and ethnicity in other societies. **ADVISORY:** Eligible for English 250 and English 260.

40325 Lec PB3 R Kreider 3.2 3.0 TR 1250-0210

SOC 10 Mass Media and Society

Transferable: CSU, UC; CSU-GE:C2, D0, IGETC:4J; GAV-GE:C2, D2

This course helps us understand the 20th century revolution in mass media by focusing on the history, economics and social impact of the newspaper, book publishing, magazine, film, television, public relations, advertising and music industries. We will study audience, propaganda and mass communication theory; we will discuss new technology, ethnic media in the U.S., ethical issues and attempts to regulate or control the media. Honors students will complete more in-depth analysis of media issues, and will finish a media-related research project. This course is also listed as JOUR 10. This course has the option of a letter grade or pass/no pass. **ADVISORY:** English 250, English 260

40318 Lec AR103 J Janes 3.2 3.0 MW 0810-0930

SOC 21 Marriage and the Family

Transferable: CSU; CSU-GE:E2; GAV-GE:E2

Survey of information on preparation for marriage, including dating, courtship, engagement, mate selection, adjustment and parenthood. Time will also be spent on the study of families and how they function. **ADVISORY:** Eligible for English 250 and English 260.

40324 Lec PB5 G Hinn 3.2 3.0 TR 0810-0930



Make a difference. Your voice counts.

POLS 27
Contemporary Leadership

CRN# 40195

Also listed as PSYC 27

Tu/Th, 9:45-11:05 am

N/S Lounges in the Student Center

One Contemporary Leader's Story: Richard (Ric) O'Barry was first recognized in the 1960s for capturing and training five dolphins that were used in the TV series *Flipper*. After Kathy, one of the *Flipper* dolphins, died in his arms in what O'Barry believed was a suicide, he made a radical transition to assertively combating the captivity industry. O'Barry was featured in *The Cove*, a film that uses covert techniques to expose the yearly dolphin drive that goes on in Taiji, Japan. In 1970, on the first Earth Day, he founded the Dolphin Project with the primary goal of releasing dolphins from captivity.

Paraphrased from http://en.wikipedia.org/wiki/Ric_O'Barry

ASB Associated Student Body

Today –
 Shaping the policies
 of the college.

Tomorrow –
 Shaping the policies
 of the world.

Join Student Government
 (408) 848-4777

CRN Type Room Instructor Hrs. Units Days Begin-End

SPANISH

SPAN 1A Elementary Spanish

Transferable: CSU, UC; CSU-GE:C2; GAV-GE:C2; CAN:SPAN2, SPAN SEQ A

Beginning course with emphasis on understanding and speaking Spanish; introduction to reading and writing Spanish. This course will also introduce students to Hispanic culture and institutions. This course has the option of a letter grade or pass/no pass.

40711 Lec HU105 A Marques 5.2 5.0 MTWR 0945-1050
 ARR TBA 2.8

40712 Lec HOL4 D Perez 5.2 5.0 MTWR 0945-1050
 ARR TBA 2.8
 Above class meets at the Hollister Briggs site.

40713 Lec HU105 A Marques 5.2 5.0 MTWR 1120-1225
 ARR TBA 2.8

40714 Lec HU105 S Malone 5.0 5.0 MW 0230-0445
 ARR TBA 2.8

40715 Lec HU105 E Schmidt 5.2 5.0 TR 0600-0820
 ARR TBA 2.8

CRN	Type	Room	Instructor	Hrs.	Units	Days	Begin-End
-----	------	------	------------	------	-------	------	-----------

 **ONLINE CLASSES:** Start by going to <http://www.gavilan.edu/disted>

You must have an email account to take an online course. Unless you have made prior arrangements with the instructor, you **MUST** log on by 11:59 pm on the first day of the course. Late adds must login within 24 hours of adding this course. If you miss the deadline you may be dropped. For help, contact your instructor or email disted@gavilan.edu.

SPAN 1B Elementary Spanish

Transferable: CSU, UC; CSU-GE:C2, IGETC:6A; GAV-GE:C2; CAN:SPAN4, SPAN SEQ A
Continuation of Spanish 1A. Further development of the four skills of understanding, speaking, reading and writing Spanish. This course will continue to emphasize the study of Hispanic culture and institutions. This course has the option of a letter grade or pass/no pass. **ADVISORY:** Spanish 1A or equivalent.

40716	Lec	HOL5	D Perez	5.2	5.0	MTWR	0830-0935
	ARR		TBA	2.8			
Above class meets at the Hollister Briggs site.							
40717	Lec	PB13	C Schalesky	5.2	5.0	MTWR	0230-0335
	ARR		TBA	2.8			
40718	Lec	HU105	A Marques	5.2	5.0	MTWR	0830-0935
	ARR		TBA	2.8			

SPAN 2B Intermediate Spanish

Transferable: CSU, UC; CSU-GE:C2, IGETC:3B, 6A; GAV-GE:C2; CAN:SPAN10, SPAN SEQ B
Review of basic structures and grammar with greater emphasis on vocabulary and idioms. Introduction to literature as it reflects the characteristics of Hispanic societies. Greater emphasis on composition as a medium of expression. This course has the option of a letter grade or pass/no pass. **ADVISORY:** Spanish 2A or equivalent.

40721	Lec	HU101	D Perez	5.2	5.0	MTWR	1250-0155
	ARR		TBA	2.8			

SPAN 8B Conversational Spanish

Transferable: CSU; GAV-GE:C2
This course requires knowledge of Spanish pronunciation, basic vocabulary, and present tense grammar. More advanced grammar and vocabulary, and cultural elements will be taught in the development of listening, speaking, basic reading and writing skills. This course has the option of a letter grade or pass/no pass. **ADVISORY:** Spanish 8A or equivalent.

40722	Lec	HU105	I Polo	3.3	3.0	W	0600-0905
-------	-----	-------	--------	-----	-----	---	-----------

SPAN 12B Spanish for Spanish Speakers

Transferable: CSU, UC; CSU-GE:C2, IGETC:6A; GAV-GE:C2, F
Continuation of 12A; through comparative analysis of selected literary works, the course develops an awareness of cultural and literary contributions from Mexico and other Spanish speaking societies. The course is taught in Spanish with emphasis on composition as a medium of expression. This course has the option of a letter grade or pass/no pass. **ADVISORY:** Basic Spanish speaking skills.

	40710	Online	D Perez	5.0	See information above about online classes.		
---	-------	--------	---------	-----	---	--	--

SPAN 23 Independent Study

Transferable: CSU
Designed to afford selected students specialized opportunities for exploring areas at the independent study level. The courses may involve extensive library work, research in the community, or special projects. May be repeated until six units of credit are accrued. This course has the option of a letter grade or pass/no pass. **REQUIRED:** The study outline prepared by the student and the instructor must be filed with the department and the dean.

40719	Ind	HU105	D Perez		2.0		
40720	Ind	HU105	A Marques		1.0		

Speech: see Communications Statistics: see Mathematics
Television: see Mass Media, Theatre Arts

THEATRE ARTS / DRAMA / TELEVISION

 **Newly approved!**

A.A. Degree in Theater Arts -Television Performance
Now students can get an AA Degree in Television Performance and production.
Certificate of Achievement in Theatre Arts Television Performance (17 units)

THEA 1 Theatre History

Transferable: CSU, UC; CSU-GE:C1, IGETC:3A; GAV-GE:C1, F
A survey of the history of theatrical performance, production and dramatic literature, including: early Greek, Roman, Asian, the Renaissance, Italian, English, modern European to contemporary American theatre. **ADVISORY:** Eligible for English 250 and English 260.

40757	Lec	TH125	J James	3.2	3.0	TR	0945-1105
-------	-----	-------	---------	-----	-----	----	-----------

THEA 3 El Teatro Campesino

Transferable: CSU, UC; CSU-GE:C1, IGETC:3A; GAV-GE:C1
Reading, viewing and discussing the work of writer/director Luis Valdez and El Teatro Campesino (The Farmworkers Theatre) is the focus of this course. It traces the historical development of the theatrical company from its creation in 1965 to the present. Students will read actos, plays and view theatrical productions performed by El Teatro Campesino. This course has the option of a letter grade or pass/no pass. **ADVISORY:** Eligible for English 250 and English 260.



See live Theatrical productions at the Playhouse in San Juan Bautista!

	40756	Online	R Gonzalez	3.0	See information above about online classes. 03/07/11 - 05/27/11		
---	-------	--------	------------	-----	--	--	--

THEA 15 Introduction to Design for Stage, Film and Television



A conceptual and practical approach to design, the class will include design projects and hands-on workshops. Students with little or no prior arts experience are encouraged to participate!

All the World's a Stage!

THEA 13 A-D Actor's Workshop presents

Something for everyone, a comedy tonight!



Stephen Sondheim's
A FUNNY THING HAPPENED ON THE WAY TO THE FORUM

Directed by John Lawton Haehl, Ph.D
Public Performances: April 29 & 30, May 6 & 7

For more information email jlawtonhaehl@gavilan.edu

Transfer to:
CSU; UC;
GAV-CE: C1

CRN Type Room Instructor Hrs. Units Days Begin-End

THEA 12A Acting: History and Practice

Transferable: CSU, UC; CSU-GE:C1; GAV-GE:C1; CAN:DRAM8

An introduction to the historical development of acting as a practice of human cultural expression. Students will acquire a vocabulary for theatre performance as an art form and analyze dramatic works in a historical context. Practice of basic acting concepts, character analysis, preparation and performances of monologues and scenes will be required in the course.

40723	L/L ARR	TH125	J Lawton-Haehl TBA	3.2 1.0	3.0	MW	1120-1240
-------	------------	-------	-----------------------	------------	-----	----	-----------

THEA 12B Acting Techniques

Transferable: CSU, UC; GAV-GE:C1

Techniques for creating characterizations for performance. Various acting approaches will be examined through research, discussion and acting exercises. This course has the option of a letter grade or pass/no pass. May be repeated two times for credit. ADVISORY: Theatre Arts 12A.

40724	L/L ARR	TH125	J Lawton-Haehl TBA	3.2 1.0	2.0	MW	1120-1240
-------	------------	-------	-----------------------	------------	-----	----	-----------

THEA 13A Actor's Workshop

Transferable: CSU, UC; GAV-GE:C1

Audition, rehearsal and performance of a theatrical production for public performance.

40732	Lab	TH125	J Lawton-Haehl	10.8	3.0	MTWR	0630-0855
-------	-----	-------	----------------	------	-----	------	-----------

THEA 13B Actor's Workshop

Transferable: CSU, UC; GAV-GE:C1

Audition, rehearsal and performance of a theatrical production for public performance.

40733	Lab	TH125	J Lawton-Haehl	10.8	3.0	MTWR	0630-0855
-------	-----	-------	----------------	------	-----	------	-----------

THEA 13C Actor's Workshop

Transferable: CSU, UC; GAV-GE:C1

Audition, rehearsal and performance of a theatrical production for public performance. ADVISORY: THEA 13B.

40734	Lab	TH125	J Lawton-Haehl	10.8	3.0	MTWR	0630-0855
-------	-----	-------	----------------	------	-----	------	-----------

THEA 13D Actor's Workshop

Transferable: CSU, UC; GAV-GE:C1

Audition, rehearsal and performance of a theatrical production for public performance. ADVISORY: Theatre Arts 13C

40735	Lab	TH125	J Lawton-Haehl	10.8	3.0	MTWR	0630-0855
-------	-----	-------	----------------	------	-----	------	-----------

THEA 14 Stage Production

Transferable: CSU, UC; GAV-GE:C1

An individualized course in technical theatre production for the performing arts. Areas of study include: scenery, lighting, props, costumes, sound, make-up, public relations/box office management or stage management. May be repeated until a maximum of 9 units are accrued. ADVISORY: Eligible for English 250 and English 260.

40736	Lab	TH125	W Klipstine	3.2	1.0	MW	1250-0210
40737	Lab	TH125	W Klipstine	6.6	2.0	MW	1250-0355
40738	Lab ARR	TH125	W Klipstine TBA	6.6 3.0	3.0	MW	1250-0355

THEA 15 Introduction to Design for Stage, Film, and Television

Transferable: CSU, UC; GAV-GE:C1

An introductory course in design and technical production for stage, film, and television. Areas of study will include scenery, lighting, costumes, and make-up. ADVISORY: Eligible for English 250 and English 260.

40761	Lec	TH125	J Lawton-Haehl	3.2	3.0	TR	1250-0210
-------	-----	-------	----------------	-----	-----	----	-----------

THEA 1 THEATRE HISTORY



Edward Hooper - New York Restaurant c. 1922

Learn about major artistic and cultural movements, read plays and texts from a variety of periods and analyze films of the historic texts in this exciting face-to-face class.

THEA 1 satisfies the ARTS requirement under the CSU-GE (Area C-1), the IGETC (Area 3A) and the AA/AS (Area C-1) Degree patterns.

MCTV/THEA 16 Television History and Practice

Create, Write, Produce, Edit
Learn, Hands on TV production!



CRN Type Room Instructor Hrs. Units Days Begin-End

THEA 16 Television History and Practice

Transferable: CSU; GAV-GE:C1

This course examines theories, history and development of television technology and current distribution practices. Programming genres and production techniques are analyzed, evaluated and compared with other societies as tools of mass communication. This course is also listed as MCTV 16. ADVISORY: Eligible for English 250 and 260.

40739	Lec	LI144	Abad	3.2	3.0	MW	1120-1240
-------	-----	-------	------	-----	-----	----	-----------

THEA 17A Television and Video Workshop

Transferable: CSU; GAV-GE:C1

An introduction to television and video technology, including pre-production, production and post-production techniques such as: camera work, studio equipment, lighting, audio plus off-line and on-line editing. This course is also listed as MCTV 17A. ADVISORY: Theatre Arts 16 Intro to TV or consent of instructor.

40740	L/L	LI144	J Frazier	5.4	3.0	TR	1250-0315
-------	-----	-------	-----------	-----	-----	----	-----------

THEA 17B Television and Video Workshop

Transferable: CSU; GAV-GE:C1

Emphasis placed on production and post-production techniques in video production. Student knowledge and skills are increased by participating in live to tape projects. May be repeated twice for credit. This course is also listed as MCTV 17B. ADVISORY: Completion of Theatre Arts 17A.

40742	L/L	LI144	J Frazier	5.4	3.0	TR	1250-0315
-------	-----	-------	-----------	-----	-----	----	-----------

THEA 19 Television and Film Acting

Transferable: CSU, UC; GAV-GE:C1

Theory and practice of acting for film and television. Students will learn basic performance techniques for the camera. Learning experiences include projects in broadcasting, reporting, commercials, public service announcements (PSA), comedy and drama. This course has the option of a letter grade or pass/no pass. May be repeated three times for credit. This course is also listed as MCTV 19.

40743	L/L ARR	LI144	J James R Gonzalez TBA	3.2 3.2	3.0	TR	1120-1240
-------	------------	-------	------------------------------	------------	-----	----	-----------

CRN Type Room Instructor Hrs. Units Days Begin-End

THEA 20 Introduction to Scriptwriting

Transferable: CSU; CSU-GE:C1

An introductory course on script development, writing and formatting for broadcast television and film production. This course has the option of a letter grade or pass/no pass. May be repeated three times for credit. ADVISORY: English 250

40745 Online R Gonzalez 3.0 Start by going to <http://www.gavilan.edu/disted> 03/11/11 - 05/27/11 You must have an email account to take this course. Unless you have made prior arrangements with the instructor, you MUST log on by 11:59 pm on the first day of the course. Late adds must login within 24 hours of adding this course. If you miss the deadline you may be dropped. For help, contact your instructor or email disted@gavilan.edu.

THEA 21 Mexican Dance and Folklore

Transferable: CSU, UC; GAV-GE:C1

Selected regional dances of Mexico, taught for technical and cultural understanding. Emphasis is given to the origin, development and styling of the material. Students are afforded the opportunity of appearing in performances. May be repeated until a maximum of 8 units are accrued.

40746 L/L TH125 J Lawton-Haehl 3.3 2.0 S 0930-1235

THEA 22 Field Work and Service

Transferable: CSU

Supervised field work within the college and with local agencies. Students serve in useful group activities in leadership roles prescribed for them by faculty or community agencies. A maximum of six units may be completed. This is a pass/no pass course. REQUIRED: Learning contracts must be filled out and signed by the student and the supervising instructor.

40747 Fld Ex TH125 M Abad 1.0

THEA 23 Independent Study

Transferable: CSU

Designed to afford selected students specialized opportunities for exploring areas at the independent study level. The courses may involve extensive library work, research in the community, or special projects. May be repeated until six units of credit are accrued. This course has the option of a letter grade or pass/no pass. REQUIRED: The study outline prepared by the student and the instructor must be filed with the department and the dean.

40748 Ind TH125 M Abad 1.0
 40749 Ind TH125 M Abad 2.0
 40750 Ind TH125 J Frazier 1.0
 40751 Ind TH125 J Frazier 2.0
 40752 Ind TH125 J Lawton-Haehl 1.0
 40753 Ind TH125 J Lawton-Haehl 2.0
 40754 Ind TH125 R Gonzalez 1.0
 40755 Ind TH125 R Gonzalez 2.0

THEA 98 Special Topics - GavTV Channel 18

Transferable: CSU

Special topics courses examine current problems or issues of interest to students within a specific discipline area. For topical content information, consult with the appropriate department chairperson. For transfer status, check with a counselor. This course may have the option of a letter grade or pass/no pass.

40758 ARR PB15 M Abad 1.0
 03/11/11 - 05/27/11
 40760 ARR PB15 M Abad 2.0
 03/11/11 - 05/27/11



Visit www.gavilan.edu/cwe or email ssweeney@gavilan.edu.

**COOPERATIVE
 WORK
 EXPERIENCE**

Get College Credit for Working or Volunteering!

If your job or volunteer work is directly related to your education or occupational goals take

CWE 190: Occupation Work Experience Education

CRN Type Room Instructor Hrs. Units Days Begin-End

VOCATIONAL PREP STUDENTS: DISABILITY

AE 600 Vocational Training I

Transferable: No

Prevocational skills for adults with impaired cognitive functioning. Entry level work preparation is emphasized. Skills taught include basic work routine orientation, communication skills, job ability assessment, and self-management skills.

40159 Lab LI204 L Franklin Open Entry/Open Exit
 40160 Lab HOPEG T Merrill/K Sato/C Brown
 Above class meets at HOPE Workshop, 8855 Murray Avenue, Gilroy. Open Entry/Open Exit
 40162 Lab HOPEH C Brown/K Sato
 Above class meets at HOPE Services, 650 San Benito St., Ste. #120, Hollister. Open Entry/Open Exit
 40163 Lab LI171 K Sato 2.0 TR 0910-1000
 Open Entry/Open Exit
 40164 Lab LI117 C Brown 8.2 W 0910-0400
 T Merrill
 Open Entry/Open Exit
 40165 Lab MHG3 T Merrill 5.6 M 0810-1250
 Above class meets at Morgan Hill Community site. Open Entry/Open Exit
 40180 Lab GYGYM K Sato 2.4 TR 1010-1110
 Open Entry/Open Exit
 40182 Lab APE120 C Brown 3.2 TR 1120-1240
 Open Entry/Open Exit
 40196 Lab HOL3 K Sato 1.2 F 0130-0230
 Above class meets at the Hollister Briggs site. Open Entry/Open Exit

AE 602 Vocational Training III

Transferable: No

Practical training and on-the-job work experience for students with disabilities. This course also provides preparation for entry level employment utilizing a number of work alternatives and settings.

40183 Lab HOPEH K Sato/C Brown
 Above class meets at HOPE Services, 650 San Benito St., Ste. #120, Hollister. Open Entry/Open Exit
 40184 Lab LI204 L Franklin
 Open Entry/Open Exit
 40186 Lab HOPEG C Brown/T Merrill
 Above class meets at HOPE Services, 8855 Murray Avenue, Gilroy. Open Entry/Open Exit

AE 603 Vocational Training IV

Transferable: No

AE 603 is a job readiness course which provides opportunities for individuals with disabilities to participate in service-learning activities and job readiness training leading to job development and placement in a community setting.

40188 Lab MHG5 T Merrill 3.7 F 0945-1250
 Above class meets at Morgan Hill Community site. Open Entry/Open Exit

AE 605 Vocational Training VI

Transferable: No

This course is designed for students with disabilities. The purpose of this course is to improve the student's ability to participate in the community, by increasing independence through acquisition of survival vocabulary, structured practice in functional reading utilizing phonics and content recognition, and increased enjoyment in reading for pleasure. Students will read stories written or revised specifically for adults with limited reading skills.

40192 L/L BU103 C Brown 1.6 R 1250-0210
 Open Entry/Open Exit

If your job or volunteer work is not directly related to your educational goals take

CWE 192: General Work Experience Education

CRN Type Room Instructor Hrs. Units Days Begin-End

AE 613 Independence Training IV

Transferable: No

This course is designed for students with disabilities. The purpose of this course is to improve the student's ability to build math competencies related to independence in daily living and the work site. The focus of the class is basic computation, consumer awareness, money management, banking and purchasing.

40193 L/L BU103 C Brown 1.6 T 1250-0210
Open Entry/Open Exit

AE 636 Adapted Physical Education

Transferable: No

An individualized program of adapted physical education activities designed to meet the needs of students who have physical limitations or disabilities. The course assists in the development and appreciation of physical activity as a regular planned contribution to one's overall well-being. This course is for the non-matriculating student, is not graded and is without college credit. ADVISORY: Students must be able to document a physical disability.

40208 Lab GYPOOL D Ellis
Open Entry/Open Exit

40209 Lab LOADCS1 K Sato 4.2 MWF 0945-1055
Class meets at Live Oak Adult Day Services, 651 West Sixth St., Gilroy. Open Entry/Open Exit

40210 Lab LOADCS1 J Maringer-Can t 3.2 TR 0945-1105
Class meets at Live Oak Adult Day Services, 651 West Sixth St., Gilroy. Open Entry/Open Exit

40212 Lab APE108 D Ellis 3.7 F 0945-1250
Specialized class for students with developmental disabilities. Open Entry/Open Exit

40213 Lab HOL6 K Sato 1.2 F 1230-0130
Above class meets at the Hollister Briggs site. Open Entry/Open Exit

Word Processing: see CSIS

WORK EXPERIENCE

CWE 190 Occupational Work Experience

Transferable: CSU

Occupational work experience for students who have a job related to their major. A training plan is developed cooperatively between the employer, college and student. (P/NP grading) 75 hours per semester paid work = 1 unit. 60 hours non-paid (volunteer) work per semester = 1 unit. May be taken for a maximum total of 16 units. Minimum 2.00 GPA. REQUIRED: Declared vocational major.

Mandatory course orientation for the following classes will be conducted February 11: 2-3 pm, March 1: 4:30-5:30 pm, April 12: 12 pm. Meetings will be held in the Student Center-North/South Lounge. Students must attend one of the three meetings. www.gavilan.edu/cwe for assignments and details. Please contact Susan Sweeney, CWE Coordinator at ssweeney@gavilan.edu for more information.

40615 Wrk Ex LI101A S Sweeney 1.0
40616 Wrk Ex S Sweeney 1.0
40617 Wrk Ex LI101A S Sweeney 3.0
40618 Wrk Ex LI101A S Sweeney 4.0

CWE 192 General Work Experience Education

Transferable: CSU

Occupational work experience for students who have a job related to their major. A training plan is developed cooperatively between the employer, college and student. (P/NP grading) 75 hours per semester paid work = 1 unit. 60 hours non-paid (volunteer) work per semester = 1 unit. May be taken for a maximum total of 16 units. Minimum 2.00 GPA.

40619 Wrk Ex LI101A S Sweeney 1.0
40620 Wrk Ex LI101A S Sweeney 2.0
40621 Wrk Ex LI101A S Sweeney 1.0
40622 Wrk Ex LI101A S Sweeney 4.0

FINAL EXAM SCHEDULE

Saturday-Friday, May 21-27, 2011

This schedule is designed to provide dates and two-hour blocks of time for Final Exams in credit courses. Final exams will begin Saturday, May 21. Classes meeting prior to 8 a.m. will take their exams during the same week, for a two-hour period beginning at the class starting hour.

All finals are to be given at the scheduled time, and in the room in which the class has regularly met during the semester. Exceptions can be granted only by the department chair and the area dean.

If a class appears not to have a time scheduled according to the chart below, please see the instructor, department chair or area dean. Instructors' office hours will be changed to accommodate the final exam schedule. Please check your instructor's office for the revised schedule.

If your class meets on these days:

Daily, M, MTuW, MTuWF, MW, MWTh, MWThF, MWF, MTh, MThF, MF, W, WTh, WThF, WF

Starts at any time between:

08:00 - 09:40
09:45 - 11:00
11:05 - 12:20
12:25 - 01:40
01:45 - 03:00
03:05 - 04:30

Your final exam will be:

Mon. May 23 08:00 - 10:00
Wed. May 25 08:00 - 10:00
Mon. May 23 10:30 - 12:30
Wed. May 25 10:30 - 12:30
Mon. May 23 01:00 - 03:00
Wed. May 25 01:00 - 03:00

If your class meets on these days:

MTu, MTuWTh, MTuTh MTuThF, MTuF, Tu, TuW, TWTh, TuWThF, TuWF, TuTh, TuThF, TuF, Th, ThF

Starts at any time between:

8:00 - 9:10
9:15 - 10:25
10:30 - 11:40
11:45 - 12:55
1:00 - 2:10
2:15 - 3:25
3:30 - 4:55

Your final exam will be:

Thur. May 26 08:00 - 10:00
Tues. May 24 08:00 - 10:00
Thur. May 26 10:30 - 12:30
Tues. May 24 10:30 - 12:30
Thur. May 26 01:00 - 03:00
Tues. May 24 01:00 - 03:00
Tues. May 24 03:30 - 05:30

Fri or Fri/Sat classes: If your class meets at ANY start time between 8-10:55 am, the final exam will be: Friday, May 27 from 8:00-10:00 am. If your class meets at ANY start time between 11:00 am - 1:55 pm, the final exam will be: Friday, May 27 from 10:30 am - 12:30 pm. If your Friday class meets at any start time between 2 pm - 4:55 pm, your final exam will be on Friday, May 27, from 1 pm - 3 pm.

Make-ups and Conflicts:

Mon. May 23 03:30 - 05:30
Wed. May 25 03:30 - 05:30
Thur. May 26 03:30 - 05:30

Exams for classes held on Saturdays, Sundays & Evenings

All classes held on:

Monday evenings Mon. May 23
Tuesday evenings Tues. May 24
Wednesday evenings Wed. May 25
Thursday evenings Thurs. May 26
Friday evenings Fri. May 27
Monday/Wednesday evenings Mon. May 23
Tuesday/Thursday evenings Tues. May 24
Saturday Sat. May 21
Sunday Sun. May 22

DISTANCE LEARNING

courses at Gavilan are offered in three different ways:



Online



Hybrid - online
and classroom



Telecourses

Online Courses at Gavilan College

Online courses allow students who have access to a computer with an internet connection to take college credit classes. Students must have an email account before they register for the online course. Students will meet their instructors and classmates online. Your instructor may schedule one or more optional meetings on campus.

BE SURE TO NOTE THE STARTING DATE OF YOUR CLASS.

Unless you have made prior arrangements with the instructor, you **MUST** login by 11:59 pm on the first day of the course. Late adds must login within 24 hours of adding this course. If you miss the deadline you may be dropped. For help, contact your instructor or email disted@gavilan.edu

ORIENTATIONS: We strongly recommend students take one of the live orientations to online courses offered in the Gavilan Library. Please go to: http://www.gavilan.edu/disted/index_help2/orientation.html for a schedule of orientations.

We encourage you to exercise the same kind of caution in a distance learning class as you would if you were taking an on-site class. Do not share personal information about yourself; do not give a stranger or new acquaintance your home phone number or address.

CRN	COURSE	DESCRIPTION	UNITS	BEGIN-END	INSTRUCTOR
40225	ACCT 20	FINANCIAL ACCT	4	2/2-5/27	Wolowitz
40002	AH 11	NUTRITION	3	2/2-5/27	Akrop
40014	AH 11	NUTRITION	3	2/2-5/27	Akrop
40919	AH 793*	PERSONAL/CAREER DEVEL	0	2/2-5/27	Sweeney
40278	ANTH 1	INTRO PHYSICAL ANTH	3	2/2-5/27	Klein
40825	ART 140	BASIC DIGITAL FILM/VIDEO	1	2/2-5/27	Beede
40500	ART 1A	ART HISTORY	3	2/2-5/27	Horn
40003	BIO 11	NUTRITION	3	2/2-5/27	Akrop
40040	BIO 11	NUTRITION	3	2/2-5/27	Akrop
40083	CD 14B	BEHAVIOR/GUID SAC	3	2/2-5/27	Hoshiko-Hagey
40085	CD 19	INTRO CAREERS/CHLDN	2	2/2-5/27	Bumgarner
40090	CD 2	EARLY CHILD DEVELOP	3	2/2-5/27	Bumgarner
40156	CD 31	TUTOR/SCH-AGE CHILD	1	2/2-5/27	Bumgarner
40603	CSIS 132	INTERMEDIATE WORD	2	2/2-5/27	Conrey
40605	CSIS 140	BASIC DIGITAL FILM/VIDEO	1	2/2-5/27	Beede
40607	CSIS 24	JAVA PROGRAMMING I	4	2/2-5/27	Van Tassel
40609	CSIS 43	C PROGRAMMING	4	2/2-5/27	Van Tassel
40614	CSIS 45	C++ PROGRAMMING I	4	2/2-5/27	Van Tassel
40610	CSIS 46	C++ PROGRAMMING II	4	2/2-5/27	Van Tassel
40612	CSIS 48	UNIX/LINUX OP. SYS	4	2/2-5/27	Van Tassel
40853	CSIS 54	PERL PROGRAMMING	0	2/2-5/27	Howell
40854	CSIS 54L	PERL PROGRAMMING LB	1	2/2-5/27	Howell
40856	CSIS 54L	PERL PROGRAMMING LB	1	2/2-5/27	Howell
40417	CSIS 571**	COMPUT ASST INSTRUC	0.5	2/2-5/27	Maringer-Cantu
40616	CWE 190	OCCUPAT WORK EXPER	1	2/2-5/27	Sweeney
40826	DM 140	BASIC DIGITAL FILM/VIDEO	1	2/2-5/27	Beede
40327	ECON 1	PRIN MACROECONOMICS	3	2/2-5/27	Carlisle
40031	ENGL 1A	COMPOSITION	3	2/2-5/27	Luoma
40037	ENGL 1A	COMPOSITION	3	2/2-5/27	Crook
40065	ENGL 1B	COMPOSITION & LIT	3	2/2-5/27	Hooper
40070	ENGL 1B	COMPOSITION & LIT	3	2/2-5/27	Warren
40094	ENGL 1C	CRITIC REASON/WRITE	3	2/2-5/27	Chaffin
40168	GUID 1	SELF ASSESSMENT	3	2/2-5/27	Tenney
40470	GUID 558**	LEARN SKILLS LAB	0.5	2/2-5/27	Overson/Burgman
40053	HE 1	HEALTH EDUCATION	3	2/2-5/27	Quatre
40054	HE 1	HEALTH EDUCATION	3	2/2-5/27	Quatre
40056	HE 2	HUMAN SEXUALITY	3	2/2-5/27	Quatre
40295	HIST 2	U.S. HISTORY	3	2/2-5/27	Guardino
40277	HUM 4	INTRO AMER CINEMA	3	2/2-5/27	Richards
40909	LIB 732*	INTRO TO ONLINE GAVILAN	0	2/2-5/27	Staff
40934	LIB 740*	INTO COMP FOR NURSING ASST	0	2/2-5/27	Howell
40935	LIB 740*	INTO COMP FOR NURSING ASST	0	2/2-5/27	Howell
40936	LIB 741*	INTO COMP FOR THE LIFE CYCLE	0	2/2-5/27	Howell
40937	LIB 742*	INTO COMP FOR NUTRITION	0	2/2-5/27	Howell
40938	LIB 742*	INTO COMP FOR NUTRITION	0	2/2-5/27	Howell
40939	LIB 742*	INTO COMP FOR NUTRITION	0	2/2-5/27	Howell
40375	MATH 5	INTRO STATISTICS	3	2/2-5/27	Knight
40136	PE 2	INTRO TO PHYS EDUC	3	2/2-5/27	Lango
40709	PHIL 6	COMPARATIVE RELIGIONS	3	2/2-5/27	Hodge
40301	POLS 1	INTRO AMERICAN GOVERNMENT	3	2/2-5/27	Turetzky
40469	PSCI 2	INTRO METEOROLOGY	3	2/2-5/27	Van Tuyt
40091	PSYC 2	EARLY CHILD DEVELOP	3	2/2-5/27	Bumgarner
40169	PSYC 5	SELF ASSESSMENT	3	2/2-5/27	Tenney
40322	SOC 1A	INTRO TO SOCIOLOGY	3	2/2-5/27	Kreider
40710	SPAN 12B	SPAN/SPAN SPEAKERS	5	2/2-5/27	Perez

* Noncredit classes. All Noncredit classes are Open-Entry/Open Exit. For more information about Noncredit classes see the section beginning on page 91.

** This class is a credit open entry/open exit class. Students can enroll anytime during the semester.

Spring Online cont.

LATE-START OR SHORT-TERM "CYBERSESSION" Sorted by date:

CRN	COURSE	DESCRIPTION	UNITS	WEEKS	BEGIN-END	INSTRUCTOR
40933	AH 793	PERSONAL/CAREER DEV	0	1	4/4-4/8	ARTEAGA
40930	AH 793	PERSONAL/CAREER DEV	0	2	12/20-12/31	ARTEAGA
40835	ART 85	WEB DESIGN I: DREAM	2	8	2/2-3/28	LAWRENCE
40572	CSIS 6	WEBPAGE AUTHORIZING I	2	8	2/7-3/25	HOWELL
40573	CSIS 6	WEBPAGE AUTHORIZING I	2	8	3/28-5/27	HOWELL
40580	CSIS 8	INTRO TO INTERNET	1	8	2/7-3/28	VENABLE
40581	CSIS 8	INTRO TO INTERNET	1	8	3/21-5/27	VENABLE
40583	CSIS 85	WEB DESIGN I: DREAM	2	8	2/2-3/28	LAWRENCE
40828	DM 6	WEBPAGE AUTHORIZING I	2	6	2/7-3/25	HOWELL
40830	DM 6	WEBPAGE AUTHORIZING I	2	8	3/28-5/27	HOWELL
40834	DM 85	WEB DESIGN I: DREAM	2	8	2/2-3/28	LAWRENCE
40827	LIB 6	WEBPAGE AUTHORIZING I	2	6	2/7-3/25	HOWELL
40829	LIB 6	WEBPAGE AUTHORIZING I	2	8	3/28-5/27	HOWELL
40745	THEA 20	INTRO SCRIPTWRITING	3	10	3/11-5/27	GONZALEZ
40756	THEA 3	EL TEATRO CAMPESINO	3	10	3/7-5/27	GONZALEZ

Thinking of online courses at Gavilan College?

Take LIB 732 first!

A FREE introduction to the world of online education...

...ONLINE!



INTRODUCTION TO ONLINE GAVILAN

Tour the classroom and all the other services available to distance learners - financial aid, library services, tutoring and counseling.

Open entry/open exit means you can jump in or out of class any time you want.

Class is listed in the Noncredit section beginning on page 91.



Hybrid Courses

Hybrid classes will be delivered partially online and also meet face to face at select locations. You must have an email account to take a distance ed course. Unless you have made prior arrangements with the instructor, come to class in person on the first day of the semester or the first day of class for short-term courses. If you do not show up on the first day you may be dropped. For help, contact your instructor or email disted@gavilan.edu.

AH 793 Personal and Career Development

40919	Online	S Sweeney	12.0			
		L1101A	S Sweeney	6.0	WR	0430-0730

ART 14 Beginning Mural Painting

40496	Online	A Rosette	3.0			
	Lab	AR102	A Rosette	4.3	F	0900-0105

ART 25A Art Methods

40514	Online	A Rosette	3.0			
	Lab	AR102	A Rosette	4.6	TR	0810-1015

BIO 15 Survey of Human Anatomy and Physiology

40442	Online	R Malley	5.0			
	Lab	LS103	R Malley	3.3	T	0600-0905

CD 25A Art Methods

40820	Online	A Rosette	3.0			
	Lab	AR102	A Rosette	4.6	TR	0810-1015

CSIS 2 Computers in Business - MS Office

40566	Online	E Venable				
	L/L	BU111	M Bryson	1.6	4.0	F 0945-1105
40567	Online	E Venable				
	L/L	BU111	M Bryson	1.6	4.0	T 0945-1105

CSIS 24 Java Programming I

40606	Online	D Van Tassel				
	Lec	MHG8	D Van Tassel	3.3	4.0	T 0600-0950
Class also meets at Morgan Hill Community site.						

CSIS 43 C Programming

40608	Online	D Van Tassel				
	Lec	L1126	D Van Tassel	3.2	4.0	MW 0945-1105

CSIS 45 C++ Programming I

40613	Online	D Van Tassel				
	L/L	L1126	D Van Tassel	3.2	4.0	MW 0945-1105

CSIS 48 UNIX/Linux Operating System

40611	L/L	MHG8	D Van Tassel	4.0	4.0	M 0600-0950
	Online		D Van Tassel			
Class also meets at Morgan Hill Community site.						

San Jose State University Telecourses at Gavilan College - Spring 2011

San Jose State University classes begin Wednesday, January 26 and last day of instruction is Tuesday, May 17, 2011

Holidays: September 6 (Labor Day), November 11 (Veteran's Day) and November 25 & 26 (Thanksgiving)

There is a \$25 site fee per class to be paid to Gavilan College.

Classes meet in PB11N.

To register for television classes or for more information on dates, times and admission fees, contact: Gavilan College at 408-848-4719 or SJSU 408-924-3624.

Orientation via videoconference will be held in PB11N. Call 408-924-3624 for day and time.

COURSE#	TITLE	DAY	TIME
EDCO 286	Theory of Organizational Change	M	4-6:45PM
EDCO 227	Dynamics of Community & School Relations	M	7-9:45PM
EDCO 267	Education & Career Planning	T	4-6:45PM
EDCO 232	Law & Ethics for Counselors	T	7-9:45PM
EDCO 268	Life Span Development Theory	W	4-6:45PM
EDCO 221	Res. Seminar in Education	W	7-9:45PM
EDCO 282	Educational Assessment for Counselors	TH	4-6:45PM
EDCO 218	Practicum in Guidance I	TH	7-9:45PM

Hollister Briggs Building

(San Benito County)



Ride
the
Bus!

We are pleased to provide the following services for your convenience at the Hollister Briggs Building satellite site:

...From Hollister to the Gilroy campus!
County Express
Operating 9 spring and 4 summer shuttles daily
www.sanbenitocountyexpress.org/

- Admissions** Accept applications for admission
Distribute class schedules
Sell parking permits for the main campus
- Registration and Records** Class registration (pay fees, clear holds, buy parking permits, etc.)
Cash, Visa, MasterCard, American Express and Discover accepted.
Add/drops
Assessment test results
Dispense forms: Transcript Requests, Repeated Course Requests, Progress Reports, High School Contracts, etc.
Sell Student Body IDs (photos taken and cards distributed)
- Orientations** Online
- Placement/Assessment** Assessment tests on a regular basis. Check website for times and locations. Schedule an appointment for an Assessment at www.gavilan.edu/admit/assess.html. Schedule an appointment for an Ability to Benefit test at the Financial Aid Office. Call (408) 848-4727.
- Counseling** See page 7 for drop-in and appointment schedule or call (408) 782-2873 for information.
- Tutoring** Once a week for Math, English and other subjects. Free to all Gavilan students. Call (831) 636-3783 for an appointment or more information.
- Health Services** First aid supplies and health education materials
- Financial Aid** Assistance with BOG Fee Waiver forms
Assistance with filling out FAFSA on the website.
- Bookstore** Purchase scantrons and green books. Buy textbooks for your Hollister classes the week before and the first week of the semester. Order textbooks online at efollett.com.
- Computer Access** Student drop-in lab available to all students registered at Gavilan College. Open during office hours.
Purchase GoPrint cards and reloads.
- Library** A Library resource lab consisting of seven computers allows students to do research, search e-books, databases and much more. Open during office hours. Library faculty on duty on Thursday mornings (9-1). Help also available via email, chat and phone.
- Career/Transfer** College catalogs, EUREKA career assessment.
- CalWORKs/CARE** Every Wednesday. For an appointment or for more information call (408) 848-4740.
- DRC** Call (831) 636-3783 for times available in Hollister.

All other services, including services for veterans, international students, basic skills students, EOPS, MESA, STEM and TRIO are available at the Gilroy main campus. Call 408-848-4800. Check catalog or website for complete listings - www.gavilan.edu.



Briggs Building
365 Fourth St.
Hollister, CA 95023
(831) 636-3783

Site Office Hours: See inside front cover.
Judy Rodriguez, Instructional Site Director
Natalie Juarez, Program Service Specialist

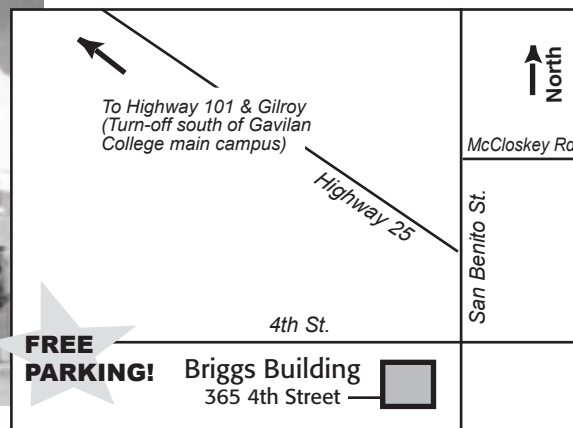

CRN	COURSE	DESCRIPTION	UNITS	DAY	TIMES	BEGIN-END	INTSRUCTOR	ROOM
40240	ACCT 121	SPREADSHEET-MS EXCL	2	MW	11:20A-1:25P	3/21-5/18	Bryson	HOL 3
40242	ACCT 121	SPREADSHEET-MS EXCL	2	W	6:00P-9:05P	3/9-5/25	Mendez	HOL 3
40502	ART 1B	ART HISTORY	3	Tu	6:00P-9:05P	2/2-5/27	McGinnis	HOL 6
40515	ART 25A	ART METHODS	3	F	4:00P-8:05P	2/2-5/27	McGinnis	HOL 1
40516	ART 25B	CONCEPT ART METHODS	3	F	4:00P-8:05P	2/2-5/27	McGinnis	HOL 1
40585	BOT 191A	WORKPLACE SKILLS	1	M	6:00P-9:35P	4/25-5/23	Mendez	HOL 3
40396	CD 3	CHILD GROWTH AND DEV	3	W	6:00P-9:05P	2/2-5/27	Brown	HOL 2
40689	CD 25A	ART METHODS	3	F	4:00P-8:05P	2/2-5/27	McGinnis	HOL 1
40690	CD 25B	CONCEPT ART METHODS	3	F	4:00P-8:05P	2/2-5/27	McGinnis	HOL 1
40540	CMUN 1A	INTRO PUBLIC SPEAK	3	MW	8:10A-9:30A	2/2-5/27	Andrade	HOL 1
40530	CMUN 10	SMALL GROUP CMUN	3	MW	9:45A-11:05A	2/2-5/27	Andrade	HOL 6
40823	CMUN 129	PRESENTATN GRAPHICS	1	MW	9:00A-11:05A	2/23-3/16	Bryson	HOL 3
40824	CMUN 129	PRESENTATN GRAPHICS	1	W	6:00P-9:45P	2/2-3/2	Mendez	HOL 3
40389	CSIS 1	COMPUTER LITERACY	2	Th	6:00P-9:05P	3/3-5/19	Thompson	HOL 3
40579	CSIS 8	INTRO TO INTERNET	1	MW	11:20A-1:25P	2/23-3/16	Bryson	HOL 3
40391	CSIS 10	BASIC PROGRAMMING	2	F	9:45A-12:05P	2/4-5/20	Thompson	HOL 3
40241	CSIS 121	SPREADSHEET-MS EXCL	2	MW	11:20A-1:25P	3/21-5/18	Bryson	HOL 3
40248	CSIS 121	SPREADSHEET-MS EXCL	2	W	6:00P-9:05P	3/9-5/25	Mendez	HOL 3
40591	CSIS 122	COMPUTER KEYBOARD	0.5	MW	9:45A-11:05A	2/2-5/18	Bryson	HOL 3
40592	CSIS 122	COMPUTER KEYBOARD	1	MW	9:45A-12:40P	2/2-5/27	Bryson	HOL 3
40593	CSIS 122	COMPUTER KEYBOARD	0.5	MW	11:20A-12:40P	2/2-5/27	Bryson	HOL 3
40596	CSIS 122	COMPUTER KEYBOARD	1	Tu	6:00P-9:05P	2/2-5/27	Hampton	HOL 3
40597	CSIS 122	COMPUTER KEYBOARD	0.5	Tu	6:00P-7:20P	2/2-5/27	Hampton	HOL 3
40811	CSIS 122	COMPUTER KEYBOARD	1	MW	11:20A-1:25P	2/2-5/18	Bryson	HOL 3
40791	CSIS 126	WORD PROCESS-MS WRD	2	MW	9:00A-11:05A	3/21-5/18	Bryson	HOL 3
40792	CSIS 126	WORD PROCESS-MS WRD	2	M	6:00P-9:35P	2/7-4/18	Mendez	HOL 3
40601	CSIS 129	PRESENTATN GRAPHICS	1	MW	9:00A-11:05A	2/23-3/16	Bryson	HOL 3
40602	CSIS 129	PRESENTATN GRAPHICS	1	W	6:00P-9:45P	2/2-3/2	Mendez	HOL 3
40923	CSIS 728*	WINDOWS FOR THE OA	0	TuTh	3:30P-4:30P	2/2-5/27	Montoya	HOL 3
40383	ECON 1	PRIN MACROECONOMICS	3	F	11:20A-2:10P	2/2-5/27	Carlisle	HOL 2
40035	ENGL 1A	COMPOSITION	3	F	9:00A-12:05P	2/2-5/27	Mora	HOL 5
40036	ENGL 1A	COMPOSITION	3	TuTh	11:20A-12:40P	2/2-5/27	Salvin	HOL 5
40061	ENGL 1A	COMPOSITION	3	W	6:00P-9:05P	2/2-5/27	Sloan	HOL 1
40096	ENGL 1C	CRITIC REASON/WRITE	3	MW	4:00P-5:20P	2/2-5/27	Hull	HOL 1
40116	ENGL 250	PRACTICAL WRITING	3	TuTh	9:45A-11:05A	2/2-5/27	Salvin	HOL 5
				Tu	8:45A-9:35A	2/2-5/27	Salvin	HOL 3
40117	ENGL 250	PRACTICAL WRITING	3	TuTh	9:45A-11:05A	2/2-5/27	Salvin	HOL 5
				Th	8:45A-9:35A	2/2-5/27	Salvin	HOL 3
40132	ENGL 250	PRACTICAL WRITING	3	MW	7:00P-8:20P	2/2-5/27	Parker	HOL 5
				M	8:30P-9:20P	2/2-5/27	Parker	HOL 5
40133	ENGL 250	PRACTICAL WRITING	3	MW	7:00P-8:20P	2/2-5/27	Parker	HOL 5
				W	8:30P-9:20P	2/2-5/27	Parker	HOL 5
40153	ENGL 260	PREP/COLLEGE READNG	3	MW	5:30P-6:50P	2/2-5/27	Parker	HOL 5
40175	ENGL 420	READING IMPROVE	3	MW	9:45A-11:05A	2/2-5/27	Scimeca	HOL 1
				F	9:10A-10:00A	2/2-5/27	Scimeca	HOL 1
40181	ENGL 420	READING IMPROVE	3	MW	9:45A-11:05A	2/2-5/27	Scimeca	HOL 1
				F	10:10A-11:00A	2/2-5/27	Scimeca	HOL 1
40258	ENGL 440	BASIC WRITING	3	MW	11:20A-12:40P	2/2-5/27	Scimeca	HOL 1
				F	11:10A-12:00P	2/2-5/27	Scimeca	HOL 1
40259	ENGL 440	BASIC WRITING	3	MW	11:20A-12:40P	2/2-5/27	Scimeca	HOL 1
				F	12:10P-1:00P	2/2-5/27	Scimeca	HOL 1
40904	ENGL 756*	GED PREPARATION	0	Sat	9:00A-12:00P	2/2-5/27	Vargas-Padilla	HOL 1
40906	ENGL 756*	GED PREPARATION	0	Sat	9:00A-12:30P	2/2-5/27	Holguin	HOL 4
40486	ESL 581	ESL PRONUNCIATION I	2	TuTh	8:45A-9:45A	2/2-5/27	Cisneros	HOL 1
40880	ESL 702A*	ESL CITIZENSHIP	0	Tu	6:00P-9:00P	2/2-5/27	Staff	HOL 1
40884	ESL 777*	ESL LIFESKILLS 1	0	TuTh	10:00A-12:00P	2/2-5/27	Manson	HOL 6
40896	ESL 780*	ESL LIFESKILLS 4	0	WF	6:30P-9:30P	2/2-5/27	Staff	HOL 6
40284	GEOG 1	PHYSICAL GEOG L/L	3	MW	9:45A-12:10P	2/2-5/27	Willahan	HOL 2
40866	GUID 191A	WORKPLACE SKILLS	1	M	6:00P-9:35P	4/25-5/23	Mendez	HOL 3
40288	HIST 1	US HISTORY	3	Tu	6:00P-9:05P	2/2-5/27	Luna	HOL 5
40289	HIST 1	US HISTORY	3	TuTh	11:20A-12:40P	2/2-5/27	Luna	HOL 2
40294	HIST 2	U.S. HISTORY	3	TuTh	9:45A-11:05A	2/2-5/27	Luna	HOL 2
40908	LIB 730*	INTERNET LITERACY	0	TuTh	2:30P-3:30P	2/2-5/27	Montoya	HOL 3
40336	MATH 205	ELEM ALGEBRA	5	MTuWTh	12:50P-1:55P	2/2-5/27	Bates	HOL 5
40348	MATH 233	INTERMED ALGEBRA	5	MTuWTh	12:50P-1:55P	2/2-5/27	Malokas	HOL 2
40350	MATH 233	INTERMED ALGEBRA	5	TuTh	6:00P-8:25P	2/2-5/27	Bates	HOL 4
40364	MATH 402	PRE-ALGEBRA	3	TuTh	11:20A-12:40P	2/2-5/27	Malokas	HOL 4
				F	12:10P-1:00P	2/2-5/27	Malokas	HOL 5
40377	MATH 5	INTRO STATISTICS	3	Tu	7:00P-9:05P	2/2-5/27	Wadia	HOL 2
				Th	7:00P-8:05P	2/2-5/27	Wadia	HOL 2
				Th	8:25P-9:15P	2/2-5/27	Wadia	HOL 2
40702	PHIL 1	INTRO PHILOSOPHY	3	TuTh	2:30P-3:50P	2/2-5/27	Hodge	HOL 2
40468	PSCI 1	PRIN PHYS SCIENCE	3	M	6:30P-9:35P	2/2-5/27	Van Tuyl	HOL 4
40812	PE 62	YOGA	1	TuTh	7:15P-8:35P	2/2-5/27	Muscari	PORTHL**
40302	POLS 1	INTRO AMERICAN GOVERNMENT	3	TuTh	2:30P-3:50P	2/2-5/27	Pinnell	HOL 1
40310	PSYC 1A	INTRO TO PSYCHOLOGY	3	TuTh	11:20A-12:40P	2/2-5/27	Oler	HOL 1
40397	PSYC 3	CHILD GROWTH AND DEV	3	W	6:00P-9:05P	2/2-5/27	Brown	HOL 2
40319	SOC 1A	INTRO TO SOCIOLOGY	3	M	6:00P-9:05P	2/2-5/27	Cervantes	HOL 6
40712	SPAN 1A	ELEMENTARY SPANISH	5	MTuWTh	9:45A-10:50A	2/2-5/27	Perez	HOL 4
40716	SPAN 1B	ELEMENTARY SPANISH	5	MTuWTh	8:30A-9:35A	2/2-5/27	Perez	HOL 5

* Noncredit classes. For additional listings of Noncredit classes in the Hollister area see pages 91-94.

** Meets at Portuguese Hall, 695 Seventh Street, Hollister

Gavilan College offers courses that meet in Morgan Hill and Hollister, including some that meet on weekends and/or start late in the semester. See spring course listings starting on page 31 and consult a counselor for guidance. Students may register online or at any of our three sites.

HOLLISTER CLASSES

We are pleased to provide the following services for your convenience at the Morgan Hill Community Center satellite site:

- Admissions** Accept applications for admission.
Sell catalogs and distribute class schedules.
Sell parking permits for main campus.
- Registration and Records** Class registration: Cash, Visa, MasterCard, American Express and Discover accepted.
Add/drops
Assessment test results
Sell Student Body IDs (photos taken and cards distributed)
Dispense forms: Transcript Requests, Repeated Course Requests, Prerequisite Challenge Forms, etc.
- Orientations** Online
- Placement/Assessment** Assessment tests on a regular basis and Ability to Benefit testing once a month. Check website for times and locations.
Schedule an appointment for an Assessment at the site. Schedule an appointment for an ATB test at the Financial Aid Office.
Call (408) 848-4727.
- DRC** **DRC - call for information and an appointment at 408 848-4767.**
- CalWORKs/CARE** CalWORKs Counseling - Every Tuesday from 3:30 - 7:30 pm by appointment 848-4740.
- Tutoring** Every Thursday from 3-6 pm - all levels of math, including accounting. Free to all Gavilan students. Call (408) 782-2873.
- Counseling** See page 7 for drop-in and appointment schedule or call (408) 782-2873 for information.
- Financial Aid** Assistance with BOG Fee Waiver forms
FAFSA and other financial aid forms available online.
- Bookstore** Buy textbooks for your Morgan Hill classes during the first week of the semester.
Order textbooks online at efollett.com.
Purchase scantrons and green books.
- Health Services** First aid supplies and health education materials
- Library** Provides research assistance via email, chat and phone.
Search e-books and databases, and much more.
- Career/Transfer** College catalogs, EUREKA career assessment.
- Computer Access** Student drop-in lab available to all students registered at Gavilan College. Open during office hours.
Purchase GoPrint cards and reloads.

All other services, including services for veterans, international students, basic skills students, EOPS, MESA, STEM, TRIO, etc. are available at the Gilroy main campus. Call 408-848-4800. Check catalog or website for complete listings - www.gavilan.edu.



Gavilan College Morgan Hill Site
17060 Monterey Rd.
Morgan Hill, CA 95037
(408) 782-2873

Site Office Hours - See inside front cover.
Lorraine Welk, Instructional Site Director
Irma Banuelos, Program Service Specialist

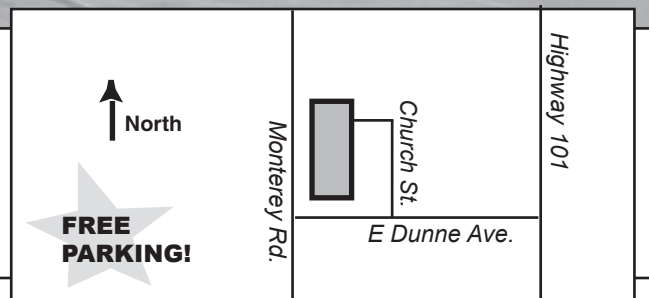

CRN	COURSE	DESCRIPTION	UNITS	DAY	TIMES	BEGIN-END	INSTRUCTOR	ROOM
40813	ACCT 105	PAYROLL ACCOUNTING	3	Th	3:00P-5:50P	2/2-5/27	Brown	MHG 3
40523	AJ 16	INTRO TO EVIDENCE	3	Tu	9:45A-12:40P	2/2-5/27	Campos	MHG 12
40940	AJ 176	CRIMINAL STREET GANGS	3	Tu	6:30P-9:35P	2/2-5/27	Pulido	MHG 10
40499	ART 1A	ART HISTORY	3	W	6:00P-9:05P	2/2-5/27	Thomas	MHG 4
40777	ART 74	ADVANCED PHOTOSHOP	3	Th	6:00P-9:05P	2/2-5/27	Grzan	MHG 5
40781	ART 75	PHOTOSHOP I	3	Tu	6:00P-9:05P	2/2-5/27	Grzan	MHG 5
40430	ASTR 1	INTRO GEN ASTRONOMY	3	Tu	6:30P-9:35P	2/2-5/27	Bumgarner	MHG 4
40586	BOT 191A	WORKPLACE SKILLS	1	F	9:00A-12:35P	4/29-5/27	Mendez	MHG 8
40267	BUS 1	FUND OF BUSINESS	3	W	6:00P-9:05P	2/2-5/27	Kurtz	MHG 3
40092	CD 2	EARLY CHILD DEVELOP	3	MW	9:45A-11:05A	2/2-5/27	Bumgarner	MHG 4
40395	CD 3	CHILD GROWTH AND DEV	3	MW	11:20A-12:40P	2/2-5/27	Bumgarner	MHG 4
40203	CD 8B	TEACH READ/WRIT	3	M	6:00P-9:05P	2/2-5/27	Malaspina	MHG 4
40082	CD 11C	SUPERVISION OF ADLT	2	Tu	6:00P-9:05P	2/2-5/27	Smith	MHG 11
40533	CMUN 1A	INTRO PUBLIC SPEAK	3	TuTh	11:20A-12:40P	2/2-5/27	Cowan	MHG 10
40526	CMUN 10	SMALL GROUP CMUN	3	TuTh	9:45A-11:05A	2/2-5/27	Cowan	MHG 10
40794	CSIS 23	INDEPENDENT STUDY	1			2/2-5/27	Van Tassel	MHG 8
40606	CSIS 24	JAVA PROGRAMMING I	4	Tu	6:00P-9:50P	2/2-5/27	Van Tassel	MHG 8
40611	CSIS 48	UNIX/LINUX OP. SYS	4	M	6:00P-9:50P	2/2-5/27	Van Tassel	MHG 8
40853	CSIS 54	PERL PROGRAMMING	3	W	6:00P-9:05P	2/2-5/27	Howell	MHG 5
40574	CSIS 74	ADVANCED PHOTOSHOP	3	Th	6:00P-9:05P	2/2-5/27	Grzan	MHG 5
40576	CSIS 75	PHOTOSHOP I	3	Tu	6:00P-9:05P	2/2-5/27	Grzan	MHG 5
40598	CSIS 126	WORD PROCESS-MS WRD	2	F	9:00A-12:35P	2/4-4/22	Mendez	MHG 5
40778	DM 74	ADVANCED PHOTOSHOP	3	Th	6:00P-9:05P	2/2-5/27	Grzan	MHG 5
40782	DM 75	PHOTOSHOP I	3	Tu	6:00P-9:05P	2/2-5/27	Grzan	MHG 5
40863	ECON 1	PRIN MACROECONOMICS	3	M	6:00P-9:05P	2/2-5/27	Truongson	MHG 5
40384	ECON 2	PRIN MICROECONOMICS	3	TuTh	9:45A-11:05A	2/2-5/27	Truongson	MHG 5
40063	ENGL 1A	COMPOSITION	3	Tu	6:00P-9:05P	2/2-5/27	Mack	MHG 3
40034	ENGL 1A	COMPOSITION	3	MW	8:10A-9:30A	2/2-5/27	Bragger	MHG 12
40064	ENGL 1A	COMPOSITION	3	F	9:00A-12:05P	2/2-5/27	Bragger	MHG 3
40066	ENGL 1B	COMPOSITION & LIT	3	MW	4:00P-5:20P	2/2-5/27	Staff	MHG 13
40134	ENGL 250	PRACTICAL WRITING	3	MW	9:45A-11:05A	2/2-5/27	Frazier	MHG 10
				M	8:45A-9:35A	2/2-5/27	Frazier	MHG 10
40135	ENGL 250	PRACTICAL WRITING	3	MW	9:45A-11:05A	2/2-5/27	Frazier	MHG 10
				W	8:45A-9:35A	2/2-5/27	Frazier	MHG 10
40879	ESL 702A*	ESL CITIZENSHIP	0	MW	9:00A-11:30A	2/2-5/27	Yu-Costa	MHG 5
40881	ESL 777*	ESL LIFESKILLS 1	0	MW	6:00P-8:30P	2/2-5/27	Yu-Costa	MHG 13
40893	ESL 779*	ESL LIFESKILLS 3	0	TuTh	9:00A-11:30A	2/2-5/27	Yu-Costa	MHG 11
40867	GUID 191A	WORKPLACE SKILLS	1	F	9:00A-12:35P	4/29-5/27	Mendez	MHG 8
40285	HIST 1	US HISTORY	3	MW	9:45A-11:05A	2/2-5/27	Mosher	MHG 12
40291	HIST 2	U.S. HISTORY	3	MW	11:20A-12:40P	2/2-5/27	Mosher	MHG 12
40376	MATH 5	INTRO STATISTICS	3	MW	6:30P-8:35P	2/2-5/27	Viarengo	MHG 12
40334	MATH 205	ELEM ALGEBRA	5	MTuWTh	12:50P-1:55P	2/2-5/27	Kercheval	MHG 10
40339	MATH 205	ELEM ALGEBRA	5	TuTh	6:00P-8:25P	2/2-5/27	Sioshansi	MHG 13
40345	MATH 233	INTERMED ALGEBRA	5	MTuWTh	12:50P-1:55P	2/2-5/27	Ward	MHG 12
40075	PE 62	YOGA	1	MW	5:00P-6:20P	2/2-5/27	Watson	MHG 10
40076	PE 62	YOGA	1	MW	5:00P-6:20P	2/2-5/27	Watson	MHG 11
40708	PHIL 4	CRITICAL THINK/WRIT	3	MW	9:45A-11:05A	2/2-5/27	Grudzen	MHG 11
40300	POLS 1	INTRO AMERICAN GOVERNMENT	3	MW	11:20A-12:40P	2/2-5/27	Banks	MHG 10
40312	PSYC 1A	INTRO TO PSYCHOLOGY	3	Th	6:00P-9:05P	2/2-5/27	Oler	MHG 10
40093	PSYC 2	EARLY CHILD DEVELOP	3	MW	9:45A-11:05A	2/2-5/27	Bumgarner	MHG 4
40398	PSYC 3	CHILD GROWTH AND DEV	3	MW	11:20A-12:45P	2/2-5/27	Bumgarner	MHG 4
40320	SOC 1A	INTRO TO SOCIOLOGY	3	TuTh	9:45A-11:05A	2/2-5/27	Kreider	MHG 13

* Noncredit classes. For additional listings of Noncredit classes in the Morgan Hill area see pages 91-94.

Gavilan College offers courses that meet in Morgan Hill and Hollister, including some that meet on weekends and/or start late in the semester. See spring course listings starting on page 31 and consult a counselor for guidance. Students may register online or at any of our three sites.

MORGAN HILL CLASSES

Early and Late Start/Short-Term Classes

These courses are offered at Gavilan's main Gilroy campus, the Morgan Hill and Hollister sites and Online.



Gilroy

CRN	COURSE	CLASS TITLE	UNITS	DAYS	# WEEKS	TIMES	DATES	INSTR	ROOM
40931	AH 793*	PERSONAL/CAREER DEV	0	MTWR	4	8:30A-12:30P	1/3-1/20	Arteaga	PB1
40932	AH 793*	PERSONAL/CAREER DEV	0	MTWR	4	1:00P-5:00P	1/3-1/20	Mendez	PB1
40541	AMT 101	GEN AIRCRAFT TECH	7.5	MTuWThF	19	8:00A-10:30A	1/13-5/27	STAFF	MP 129
40543	AMT 111	AIRFRAME STRUCTURES	13.5	MTuWThF	19	10:35A-3:30P	1/13-5/27	STAFF	MP 129
40544	AMT 121	POWERPLT SYS/TECH	14	TuWThF	19	8:30A-3:00P	1/13-5/27	Flippen	PB 15
40545	AMT 123	INDEPENDENT STUDY	1		19		1/13-5/27	Flippen	MP 129
40077	ATH 35	INTERCOL BASKETBALL	1	MTuWThF	8	2:30P-4:30P	2/2-3/25	Addison	GY GYM
40455	BIOT 104	BIOT SEMINAR	1	Sat	8	9:10A-11:00A	2/2-4/2	Bach	PS 105
40822	CMUN 129	PRESENTATN GRAPHICS	1		8		3/28-5/20	Venable	BU 110
40313	CSIS 1	COMPUTER LITERACY	2	MW	7	9:00A-11:05A	2/2-3/23	Gaffney	BU 111
40387	CSIS 1	COMPUTER LITERACY	2	MW	7	9:00A-11:05A	3/28-5/18	Gaffney	BU 111
40388	CSIS 1	COMPUTER LITERACY	2	Tu	11	6:00P-9:05P	3/1-5/17	Gaffney	BU 110
40390	CSIS 10	BASIC PROGRAMMING	2	TuTh	11	9:45A-11:05A	3/1-5/19	Thompson	LI 126
40789	CSIS 124	WINDOWS FUNDAMENTAL	1	Tu	10	12:50P-2:10P	2/22-5/3	Milar	BU 111
40599	CSIS 128	DATABASE-MS ACCESS	2	W	11	11:20A-2:10P	3/2-5/18	Conrey	BU 111
40600	CSIS 129	PRESENTATN GRAPHICS	1		8		3/28-5/20	Venable	BU 110
40604	CSIS 134	INTERMEDIATE EXCEL	2	Th	14	11:20A-2:10P	2/10-5/19	Conrey	BU 111
40901	ENGL 747*	FILM AND LITERACY	0	R	4	6:00P-9:30P	2/17-4/14	Hooper	HU102
40185	PE 27	BASKETBALL	0.5	TuTh	8	2:30P-4:30P	4/5-5/28	Addison	GY GYM
40187	PE 37	SOFTBALL	1	MTuWThF	4	10:00A-1:30P	1/3-1/28	Dequin	GY GYM
40200	PE 46	AGILITY/STRENGTH DEV	0.5	MTuWTh	8	3:10P-4:00P	3/28-5/28	Lango	GY GYM
40202	PE 61	SWIM FOR FITNESS	0.5	TuTh	8	5:15P-6:35P	3/28-5/28	Dodd	GY POOL
40207	PE 65	BASEBALL	1	MTuWThF	4	1:00P-4:30P	1/3-1/28	Andrade	GY GYM
40758	THEA 98	SPECIAL TOPICS	1		10		3/11-5/27	Abad	PB 15
40760	THEA 98	SPECIAL TOPICS	2		10		3/11-5/27	Abad	PB 15

Hollister

CRN	COURSE	CLASS TITLE	UNITS	DAYS	# WEEKS	TIMES	DATES	INSTR	ROOM
40240	ACCT 121	SPREADSHEET-MS EXCL	2	MW	8	11:20A-1:25P	3/21-5/18	Bryson	HOL 3
40242	ACCT 121	SPREADSHEET-MS EXCL	2	W	10	6:00P-9:05P	3/9-5/25	Mendez	HOL 3
40585	BOT 191A	WORKPLACE SKILLS	1	M	4	6:00P-9:35P	4/25-5/23	Mendez	HOL 3
40389	CSIS 1	COMPUTER LITERACY	2	Th	11	6:00P-9:05P	3/3-5/19	Thompson	HOL 3
40391	CSIS 10	BASIC PROGRAMMING	2	F	15	9:45A-12:05P	2/4-5/20	Thompson	HOL 3
40241	CSIS 121	SPREADSHEET-MS EXCL	2	MW	8	11:20A-1:25P	3/21-5/18	Bryson	HOL 3
40248	CSIS 121	SPREADSHEET-MS EXCL	2	W	11	6:00P-9:05P	3/9-5/25	Mendez	HOL 3
40591	CSIS 122	COMPUTER KEYBOARD	0.5	MW	15	9:45A-11:05A	2/2-5/18	Bryson	HOL 3
40811	CSIS 122	COMPUTER KEYBOARD	1	MW	15	11:20A-1:25P	2/2-5/18	Bryson	HOL 3
40791	CSIS 126	WORD PROCESS-MS WRD	2	MW	11	9:00A-11:05A	3/21-5/18	Bryson	HOL 3
40792	CSIS 126	WORD PROCESS-MS WRD	2	M	10	6:00P-9:35P	2/7-4/18	Mendez	HOL 3
40601	CSIS 129	PRESENTATN GRAPHICS	1	MW	4	9:00A-11:05A	2/23-3/16	Bryson	HOL 3
40602	CSIS 129	PRESENTATN GRAPHICS	1	W	4	6:00P-9:45P	2/2-3/2	Mendez	HOL 3
40579	CSIS 8	INTRO TO INTERNET	1	MW	3	11:20A-1:25P	2/23-3/16	Bryson	HOL 3
40823	CMUN 129	PRESENTATN GRAPHICS	1	MW	4	9:00A-11:05A	2/23-3/16	Bryson	HOL 3
40824	CMUN 129	PRESENTATN GRAPHICS	1	W	4	6:00P-9:45P	2/2-3/2	Mendez	HOL 3
40866	GUID 191A	WORKPLACE SKILLS	1	M	5	6:00P-9:35P	4/25-5/23	Mendez	HOL 3

Morgan Hill

CRN	COURSE	CLASS TITLE	UNITS	DAYS	# WEEKS	TIMES	DATES	INSTR	ROOM
40586	BOT 191A	WORKPLACE SKILLS	1	F	5	9:00A-12:35P	4/29-5/27	Mendez	MHG-8
40598	CSIS 126	WORD PROCESS-MS WRD	2	F	11	9:00A-12:35P	2/4-4/22	Mendez	MHG-5
40867	GUID 191A	WORKPLACE SKILLS	1	F	4	9:00A-12:35P	4/29-5/27	Mendez	MHG-8

Online

CRN	COURSE	CLASS TITLE	UNITS	# WEEKS	DATES	INSTR
40930	AH 793*	PERSONAL/CAREER DEV	0	2	12/20-12/31	Arteaga
40933	AH 793*	PERSONAL/CAREER DEV	0	2	4/4-4/8	Arteaga
40835	ART 85	WEB DESIGN I: DREAM	2	8	2/2-3/28	Lawrence
40572	CSIS 6	WEBPAGE AUTHORIZING I	2	8	2/7-3/25	Howell
40573	CSIS 6	WEBPAGE AUTHORIZING I	2	8	3/28-5/27	Howell
40580	CSIS 8	INTRO TO INTERNET	1	8	2/7-3/28	Venable
40583	CSIS 85	WEB DESIGN I: DREAM	2	8	2/2-3/28	Lawrence
40828	DM 6	WEBPAGE AUTHORIZING I	2	6	2/7-3/25	Howell
40830	DM 6	WEBPAGE AUTHORIZING I	2	8	3/28-5/27	Howell
40834	DM 85	WEB DESIGN I: DREAM	2	8	2/2-3/28	Lawrence
40827	LIB 6	WEBPAGE AUTHORIZING I	2	6	2/7-3/25	Howell
40829	LIB 6	WEBPAGE AUTHORIZING I	2	8	3/28-5/27	Howell
40756	THEA 3	EL TEATRO CAMPESINO	3	10	3/7-5/27	Gonzalez
40745	THEA 20	INTRO SCRIPTWRITING	3	10	3/11-5/27	Gonzalez

* Noncredit classes.

King's Canyon National Park

CRN	COURSE	CLASS TITLE	UNITS	DAYS	TIMES	DATES	INSTR	ROOM
40845	BI021	FIELD ECOLOGY**	4	Th	6:30P-8:35P	1/06	Morales	LS102
				ThFSat	6:00A-10:00P	1/13-1/15	Morales	KINGS CYN
				Sun	6:00A-8:00P	1/16	Morales	KINGS CYN
				F	9:00A-2:00P	1/21	Morales	LS102

** King's Canyon National Park Trip. See class information on page 39.

NONCREDIT PROGRAM

This program is open to all students and currently offers various classes of interest to the community. All classes are free of charge.* There are no tests, no quizzes and no letter grades. Registration will take place in the Admissions & Records Office or on the first day of class. Students should contact Debra Casella in the Noncredit Office directly with any questions at (408) 852-2824.

* Some classes may require a materials fee.

**NO QUIZZES!
NO TESTS!
NO LETTER GRADES!
NO FEES!**

SPRING CLASSES

All noncredit classes are open entry/exit and free of charge.

CRN Type Room Instructor Hrs. Units Days Begin-End

ALLIED HEALTH

AH 741 Body Dynamics and Aging

Transferable: No

This course is designed for the 55+ adult student to provide awareness and knowledge of physical fitness, stress management and nutrition to personal health. Discussions will focus on nutrition, sleep disorders, depression, leisure/social activities and chronic conditions that effect the body as aging occurs.

40865 Lec CRC1 MDunn 1.8 W 1030-1200

This class is held at the Centennial Recreation Center in Morgan Hill.

AH 793 Personal and Career Development

Transferable: No

A wide variety of lectures on general themes offered to students throughout the academic year who want short-formatted content to augment their personal, academic and career development. General themes to be explored are: Communication, Interpersonal Skills, Pre-employment, Decision-Making, Financial Literacy, Career and Personal Development and Self-Management with Nutrition. This noncredit course is a combination of lecture, self-assessments, group activities and individual modules.

40931 Lab PB1 BArteaga 16.0 MTWR 0830-1230
01/03/11 - 01/20/11

40932 Lab PB1 FMendez 16.0 MTWR 0100-0500
01/03/11 - 01/20/11

40919 Online LSweeney 12.0
LI101A SSweeney 6.0 WR 0430-0730

 Entry/Open Exit. This HYBRID lecture/online class will be delivered partially over the Internet. See the online syllabus for details. <http://www.gavilan.edu/disted/>

ONLINE:

 40930 Online BArteaga
12/20/10 - 12/31/10 This open-entry/open-exit online class will be delivered entirely over the Internet. After enrolling, start the class by going to <http://www.gavilan.edu> and log into the system. You must have an email account to take this course. For help, contact your instructor or email disted@gavilan.edu.

 40933 Online BArteaga 32.0
04/04/11 - 04/08/11 This open-entry/open-exit online class will be delivered entirely over the Internet. After enrolling, start the class by going to <http://www.gavilan.edu> and log into the system. You must have an email account to take this course. For help, contact your instructor or email disted@gavilan.edu.

CRN Type Room Instructor Hrs. Units Days Begin-End

ART

ART 760 Arts and Crafts I for Older Adults

Transferable: No

A general survey of arts and crafts with an emphasis on exercises and experiments with methods and materials, including: painting, drawing, color theory, composition and rendering, batik or tie-dye, quilting or needlepoint, crocheting or knitting and block printing.

40860 Lab CRC1 RGupta 3.6 R 0100-0400

This class meets at the Centennial Recreation Center, Cafeteria, Morgan Hill.

ART 761 Arts and Crafts II for Older Adults

Transferable: No

A general survey of arts and crafts with an emphasis on exercises and experiments with methods and materials, including: Metal, leather, fibers, glass, wood, and paper crafts. The crafts will be for both decorative or utilitarian.

40864 Lab HVME1 PDickerson 3.6 F 0900-1200

This class is held at Hacienda Valley Mobile Estates in Morgan Hill.

COMPUTER SCIENCE & INFORMATION SYSTEMS

CSIS 728 Windows for the Older Adult

Transferable: No

This course is designed as an introductory course for the older adults to learn Windows operations, file management and other Windows Fundamentals.

40922 Lab CTC2 DPayne 3.0 T 0900-1130

This class is held at South Valley Middle School in the GUSD /Gavilan Computer Technology Center, Room 2, in Gilroy.

40923 Lab HOL3 MMontoya 2.4 TR 0330-0430

Above class meets at the Hollister Briggs site.

CSIS 729 Word Processing-MS Word for the Older Adult

Transferable: No

A course designed for older adults (55+) to develop word processing skills to write and edit simple documents, format text, use bullets, create tables, insert clipart and use other features of the toolbar.

40924 Lec CTC2 DPayne 3.0 R 0900-1130

This class is held at South Valley Middle School in the GUSD /Gavilan Computer Technology Center, Room 2, in Gilroy.

CRN	Type	Room	Instructor	Hrs.	Units	Days	Begin-End
-----	------	------	------------	------	-------	------	-----------

ENGLISH**ENGL 747 Film and Literacy****Transferable:** No

This course utilizes film to build college-level reading, writing, and critical thinking skills.

40901	Lec	HU102	J Hooper	4.2	R	0600-0930
-------	-----	-------	----------	-----	---	-----------

Class meets 5 Thursdays, 02/17, 03/10, 03/17, 03/24 and 04/14.

ENGL 749 Writers' Workshop**Transferable:** No

Writers' Workshop is an open enrollment class that allows community members and students from all disciplines to participate in a regularly scheduled, instructor-facilitated writing response group. Activities include focused response to participants' writing, generative writing games and prompts and interaction with visiting writers and scholars.

40929	Lec	LI120	S Sandler	3.0	TR	0830-0930
	Lec	LI120	K Smith	3.0	W	0300-0600

Above class meets at the Writing Center.

ENGL 756 GED Preparation**Transferable:** No

This course is designed to prepare the student to pass the five General Education Development (GED) tests in Writing, Social Studies, Science, Literature and Mathematics. English grammar and usage, reading comprehension, writing, vocabulary and computational skills are emphasized. The course is designed for students who are 18 years of age or older and elect to take the High School Equivalency Examination. This course may be repeated three times.

40904	Lab	HOL1	M Vargas-Padilla	3.6	S	0900-1200
-------	-----	------	------------------	-----	---	-----------

Above class meets at the Hollister Briggs site. This class is taught in Spanish (Esta clase se enseña en Español).

40906	Lab	HOL4	D Holguin	4.2	S	0900-1230
-------	-----	------	-----------	-----	---	-----------

Above class meets at the Hollister Briggs site.

40905	Lab	SVALLY	D Holguin	3.0	T	0630-0900
-------	-----	--------	-----------	-----	---	-----------

This class is held at South Valley Middle School, Room E-5, in Gilroy. This class is taught in both English and Spanish (Esta clase se enseña en Inglés y Español).

ENGLISH AS A SECOND LANGUAGE**ESL 702A ESL Citizenship****Transferable:** No

This course is designed for second language learners that want to prepare for the United States Citizenship test given by the Department of Immigration and U. S. Naturalization Services. The focus will be on communicative English skills and knowledge of American History and Government required for passing the test to become a citizen of the United States. Readings are at the high-beginning/low-intermediate ESL level and will focus on the historical period beginning in the 1600's on through to 1980.

40879	Lec	MHG5	E Yu-Costa	6.0	MW	0900-1130
-------	-----	------	------------	-----	----	-----------

Above class meets at Morgan Hill Community site.

40878	Lec	STF1	D Stuker	3.6	TR	0600-0730
-------	-----	------	----------	-----	----	-----------

This class is held at the St. Frances Building in Gilroy.

40880	Lec	HOL1	Staff	3.6	T	0600-0900
-------	-----	------	-------	-----	---	-----------

Above class meets at the Hollister Briggs site.

CRN	Type	Room	Instructor	Hrs.	Units	Days	Begin-End
-----	------	------	------------	------	-------	------	-----------

ESL 704A ESL for the Workplace**Transferable:** No

This is part A of a content-based integrated skills course for ESL students who want to prepare for immediate entry into the job force. Students expand their language skills within the realm of the work world and specific vocational career of interest while also developing the soft skills needed in the workplace. This course is a combination of lecture, lab, and self-paced instruction. This course may be repeated three times.

40926	Lab	CTC1	L Rivoallon	7.2	MWF	0900-1100
-------	-----	------	-------------	-----	-----	-----------

This class is held at South Valley Middle School in the GUSD /Gavilan Computer Technology Center, Room 1, in Gilroy.

40928	Lab	JS1	N Vargas	7.2	MT	0500-0800
-------	-----	-----	----------	-----	----	-----------

This class is held at Jasmine Square Apartments in Morgan Hill.

40927	Lab	CTC1	M Vargas-Padilla	7.2	TWR	0700-0900
-------	-----	------	------------------	-----	-----	-----------

This class is held at South Valley Middle School in the GUSD /Gavilan Computer Technology Center, Room 1, in Gilroy.

ESL 775 ESL Literacy I**Transferable:** No

This is a pre-ESL survival course that is designed for students with very limited reading/writing skills. The focus is on letter formation, sight-sound recognition and decoding skills. ADVISORY: Placement by the CASAS test.

40898	Lec	ROH	S STAFF	6.0	MW	0600-0830
-------	-----	-----	---------	-----	----	-----------

This class is held at R.O. Hardin Elementary School in Hollister.

ESL 777 ESL Lifeskills 1**Transferable:** No

This is the first course in a series of survival English classes for students with very little oral or written English competency. It will give students basic vocabulary and familiarity in life skill areas such as the family, food, health, and occupations to manage in the real world. The course emphasizes oral communication and integrates listening, speaking, reading, and writing. ADVISORY: Placement into ESL Lifeskills by the CASAS placement test.

40882	Lec	ELIOT	D Payne	6.6	MWF	0810-1000
-------	-----	-------	---------	-----	-----	-----------

This class is held at Eliot Elementary School Library.

40887	Lec	ELROBL	L Rivoallon	6.0	TR	0830-1100
-------	-----	--------	-------------	-----	----	-----------

This class is held at El Roble Elementary School, Room C-11 in Gilroy.

40884	Lec	HOL6	H Manson	6.0	TR	1000-1200
-------	-----	------	----------	-----	----	-----------

Above class meets at the Hollister Briggs site.

40885	Lec	ROH	C Annotti	6.0	MW	0600-0830
-------	-----	-----	-----------	-----	----	-----------

This class is held at R.O. Hardin Elementary in Hollister.

40886	Lec	CALAVR	J Villicana	6.0	MW	0600-0830
-------	-----	--------	-------------	-----	----	-----------

This class is held at Calaveras Elementary School in Hollister.

40888	Lec	BROWNL	L Camacho-Light	7.2	TR	0600-0900
-------	-----	--------	-----------------	-----	----	-----------

This class is held at Brownell Elementary School, Room 37, in Gilroy.

40881	Lec	MHG13	E Yu-Costa	6.0	MW	0600-0830
-------	-----	-------	------------	-----	----	-----------

Above class meets at Morgan Hill Community site.

All noncredit classes are open entry/exit and free of charge.

CRN Type Room Instructor Hrs. Units Days Begin-End

ESL 778 ESL Lifeskills 2

Transferable: No

This is the second course in a series of classes in survival English for students with very little oral or written English competency. It will give students basic vocabulary and familiarity in life skill areas such as the family, food, health, and occupations to manage in the real world. The course emphasizes oral communication and integrates listening, speaking, reading, and writing. **ADVISORY:** Placement into ESL Lifeskills by the CASAS placement test and successful completion of ESL 777.

40889 Lec SBCL G Segovia-Avalo 7.2 TR 0900-1200
This class is held at the San Benito County Library.

40890 Lec SUNNY M Vallejo 6.0 TR 0600-0830
This class is held at Sunnyslope Elementary School in Hollister.

ESL 779 ESL Lifeskills 3

Transferable: No

This is the third in a series of classes in survival English for students with little oral or written English competency. It will give students expanded basic vocabulary and familiarity in life skill areas such as the weather, transportation, employment, and American holidays and customs to manage in the real world. The course emphasizes oral communication and integrates listening, speaking, reading, and writing. **ADVISORY:** Placement into ESL Lifeskills by the CASAS placement test and successful completion of ESL 778.

40893 Lec MHG 11 E Yu-Costa 4.8 TR 0900-1130
Above class meets at Morgan Hill Community site.

40894 Lec CTC3 S Morley 7.2 MWF 0900-1100
This class is held at South Valley Middle School in the GUSD/Gavilan Computer Technology Center, Room 3 in Gilroy.

40892 Lec SVALLY-7 S Morley 6.0 MW 0630-0900
This class is held at South Valley Middle School, Room E-7, in Gilroy.

ESL 780 ESL Lifeskills 4

Transferable: No

This is the fourth course in a series of survival English for students with little oral or written English competency. It will give students expanded basic vocabulary and familiarity in life skill areas such as weather, transportation, employment, and American holidays and customs to manage in the real world. The course emphasizes oral communication and integrates listening, reading, writing. **ADVISORY:** Placement into ESL Lifeskills by the CASAS placement test and successful completion of ESL 779.

40896 Lec HOL 6 Staff 7.2 WF 0630-0930
Above class meets at the Hollister Briggs site.

ESL 781 ESL Lifeskills 5

Transferable: No

This is the fifth course in a series of survival English for students with beginning oral or written English competency. It will reinforce basic skills learned and continue to develop vocabulary and ease of communication in life skill areas such as the family, the larger community, health, employment, and leisure activities to manage in the real world. The course emphasizes oral communication and integrates listening, speaking, reading, and writing. **ADVISORY:** Placement into ESL Lifeskills by the CASAS placement test and successful completion of ESL 780.

40897 Lec SVALLY L Hasbany 6.0 MW 0630-0900
This class is held at South Valley Middle School, Room E-7, in Gilroy.

Classroom Locations: Refer to "How to Use This Schedule" on page 5.



Coming in Spring 2011!
Career Training

- Solar Technology
- Paralegal
- Human Resources Management
- EKG Technician
- Veterinary Assistant
- Basic Water Distribution
- Backflow Prevention
- Wastewater Treatment
- Medical Transcription

For more information, visit Community Education at www.GavilanCE.com or give us a call at 408-852-2801.

Gavilan College
Community Education's
Water Training Program

Did you know that within the next 5-10 years, 50% of the water workforce will retire? To fill this gap, Gavilan College Community Education began offering water training programs in October of 2009. Since then, we have offered nearly 75 courses of training in Basic and Advanced Water Distribution, Backflow Prevention, Water/Wastewater Math, Water/Wastewater Operations, Water Treatment Plant Operations, state test preparation courses and more. Having served over 200 students in the Monterey Bay, Gilroy, Hollister and Watsonville area, we have built partnerships with local employers, regional experts and various organizations to meet student/future employee needs. Visit our website at www.GavilanCE.com to learn more about our water training programs or give us a call at 408-852-2801 to get on our mailing list.



CRN Type Room Instructor Hrs. Units Days Begin-End

HUMANITIES

HUM 767 Film Classics

Transferable: No

This class is designed to study the facts, fantasy, history and trivia of classic and modern films. The background and history of each film and its performance will be compared and contrasted.

40900 Lab JDA1 L Sendejas 3.6 F 1000-0100

This class is held at Jovenes de Antano in Hollister.

40899 Lab PLY G Richards 3.6 W 0200-0500

This class is held at the Morgan Hill Playhouse.

LIBRARY

LIB 730 Internet Literacy for Older Adults

Transferable: No

A class for older adults to learn email techniques, how to find information on their interests, news sources, and the skill of browsing online, as well as how best to use the local public library online services, online shopping, search strategies, and interactive games.

40908 Lec HOL3 M Montoya 2.4 TR 0230-0330

Above class meets at the Hollister Briggs site.

LIB 732 Introduction to Online Gavilan

Transferable: No

Introduction to the online classes and student services at Gavilan College. This course will show students how to log into their online courses, find lectures, assignments and exams, take part in online class discussions, submit attachments, and view their grades. The course will also cover all the online student services available to the distant student, including counseling, library resources, records and grades, financial aid, tutoring and technical support.

40909 Online Staff

This open-entry/open-exit online class will be delivered entirely over the Internet. After enrolling, start the class by going to <http://www.gavilan.edu> and log into the system. You must have an email account to take this course. For help, contact your instructor or email disted@gavilan.edu.

LIB 740 Information Competency for Nursing Assistants

Transferable: No

Online information competency modules that step through the process of finding and evaluating online health resources. These tutorials are paced with AH 180 (Fundamentals of Nursing - Convalescent).

40934 Online Howell J

You must have an email account to take this course. Start your course by going to <http://www.gavilan.edu/disted>. Please log on by 11:59 pm on the first day of the course. For help, contact your instructor or email disted@gavilan.edu.

40935 Online Howell J

You must have an email account to take this course. Start your course by going to <http://www.gavilan.edu/disted>. Please log on by 11:59 pm on the first day of the course. For help, contact your instructor or email disted@gavilan.edu.

All noncredit classes are open entry/exit and free of charge.

CRN Type Room Instructor Hrs. Units Days Begin-End

LIB 741 Information Competency for the Life Cycle

Transferable: No

Online information competency modules that step through the process of finding and evaluating online health resources. These tutorials are paced with AH3 (The Person in the Life Cycle).

40936 Online Howell J

You must have an email account to take this course. Start your course by going to <http://www.gavilan.edu/disted>. Please log on by 11:59 pm on the first day of the course. For help, contact your instructor or email disted@gavilan.edu.

LIB 742 Information Competency for Nutrition

Transferable: No

Online information competency modules that step through the process of finding and evaluating online health resources. These tutorials are paced with AH11 (Nutrition).

40937 Online Howell J

You must have an email account to take this course. Start your course by going to <http://www.gavilan.edu/disted>. Please log on by 11:59 pm on the first day of the course. For help, contact your instructor or email disted@gavilan.edu.

40938 Online Howell J

You must have an email account to take this course. Start your course by going to <http://www.gavilan.edu/disted>. Please log on by 11:59 pm on the first day of the course. For help, contact your instructor or email disted@gavilan.edu.

40939 Online Howell J

You must have an email account to take this course. Start your course by going to <http://www.gavilan.edu/disted>. Please log on by 11:59 pm on the first day of the course. For help, contact your instructor or email disted@gavilan.edu.

MUSIC

MUS 763 Music Encounters

Transferable: No

A class for older adults that provides musical activities to stimulate and sustain their auditory function, discernment of sounds and manual dexterity. Students will enjoy music, new and old, by listening, singing, playing and creating music in a group setting.

40912 Lec SOLB7 A Quartuccio 3.7 W 0600-0905

Above class meets at Solorsano Middle School, 7121 Grenache Way, Gilroy.

40913 Lec MU101 B Ruggles 3.7 T 0655-1000

PHYSICAL EDUCATION

PE 716 Music/Movement and Health

Transferable: No

This course is designed to assist older adults in improving overall health through movement, music and relaxation techniques. Rhythmical movement will be adjusted to suit individual students mobility needs.

40916 Lab CRC1 B Mendonca 4.8 TR 1000-1200

This class is held at the Centennial Recreation Center in Morgan Hill.

40917 Lab JDA1 M Host 1.2 T 1100-1200

This class is held at Jovenes de Antano in Hollister.

Classroom Locations: Refer to "How to Use This Schedule" on page 5.



ROP Courses

Spring classes begin February 2.
REGISTER EARLY!

Regional Occupational Program (ROP) training is offered to residents of Santa Clara and San Benito Counties by the Santa Clara County Office of Education. Some classes are offered at Gavilan College. In some of the classes, students may earn high school or college credit, and upon completion they may be eligible for advanced placement at Gavilan College. ROP provides students with training to secure jobs, upgrade skills, or prepare for advanced career education. Students must be 16 years of age or older to participate. Classes are free for both high school students and adults. Gavilan College fees are charged for Gavilan College credit. ROP classes may have additional fees for textbooks and supplies. For information on ROP courses taught at Gavilan College, call 408-848-4816.

Students enrolled in ROP classes do not qualify for Financial Aid.

For information about Course-to-Course Articulation Agreements for High School Students and additional ROP sites in the Gavilan College district, see page 97.

ROP Accounting

General Office Accounting

This course is designed to prepare students for entry-level office accounting positions. Emphasis is on practical accounting applications. This course has the option of a letter grade or pass/no pass. ADVISORY: Eligible for Mathematics 205. For college credit, enroll in Gavilan's ACCT 103.

Room	Instructor	Day	Time
BU103	R Brown	M	0300-0550

Payroll Accounting

This is an introductory course in payroll accounting. Topics include: payroll laws and regulations, computation of wages and salaries, Social Security taxes, income tax withholding, employer taxes, payroll tax filing and reporting, and other related topics. This course has the option of a letter grade or pass/no pass. ADVISORY: Eligible for Mathematics 205, completion of Accounting 101. For college credit, enroll in Gavilan's ACCT 105.

Room	Instructor	Day	Time
MHG3	R Brown	R	0300-0550

Class meets at Morgan Hill Community site.

Computerized Accounting - QuickBooks

An introduction to computer-assisted accounting. Hands-on use of a microcomputer menu-driven accounting package to do general ledger, sales journal, cash receipts journal, cash payments journal, purchases journal, payroll, receivables, payables and related financial reports. This course has the option of a letter grade or pass/no pass. Repeatable whenever a new software package is adopted. This course is also listed as CSIS 120. ADVISORY: CSIS 1 or CSIS 2 or the equivalent computer experience. ACCT 20 or ACCT 101 or ACCT 103 or ACCT 105 or the equivalent accounting experience. For college credit, enroll in Gavilan's ACCT 120.

Room	Instructor	Day	Time
BU111	R Brown	T	0300-0550

ROP Business Office Technology

Medical Terminology for the Office

This course introduces fundamentals of medical word building used in the health profession (prefixes, word roots, suffixes and abbreviations) as well as review of body systems, with emphasis on analysis, definition, spelling and pronunciation. This course had the option of a letter grade or pass/no pass. ADVISORY: Eligible for English 250 and English 260. For college credit, enroll in Gavilan's BOT 180.

Room	Instructor	Day	Time
BU120	D Knapp	T	0600-0905

Medical Billing - MediSoft

This course in computerized billing procedures for a medical office uses MediSoft software. Students will learn the patient billing features of this software and complete a capstone simulation giving them hands-on realistic medical front office practice. This course has the option of a letter grade or pass/no pass. May be repeated three times for credit. ADVISORY: Eligible for English 250. Some computer experience. For college credit, enroll in Gavilan's BOT 181.

Room	Instructor	Day	Time
BU110	D Knapp	R	0600-0905

Medical Office Procedures

This specialized course includes medical office procedures, patient record management, coding/billing for private/government health insurance programs, and professional ethics. May be repeated three times for credit. This course has the option of a letter grade or pass/no pass. PREREQUISITE: BOT 180 and CSIS 126 with credit or a grade of C or better or experience using Microsoft Word. ADVISORY: Eligible for English 250 and Mathematics 402. For college credit, enroll in Gavilan's BOT 182.

Room	Instructor	Day	Time
BU110	D Knapp	W	0600-0905

Workplace Skills

Workplace Skills teaches skills vital to workplace success. The topic for 191A is Interpersonal Communication. Need not be taken in sequence. This is a pass/no pass course. For college credit, enroll in Gavilan's BOT 191A.

Room	Instructor	Day	Time
MHG5	F Mendez	F	0900-1235

04/29/11 - 05/27/11 Above class meets at Morgan Hill Community site.

Room	Instructor	Day	Time
HOL3	F Mendez	M	0600-0935

04/25/11 - 05/23/11 Above class meets at the Hollister Briggs site.

ROP Clinical Medical Assisting

Advanced Clinical Medical Assisting

Course provides instruction and clinical experience in advanced concepts of clinical medical assisting including specialty procedures and treatments. PREREQUISITE: AH 170 with a grade of C or better or equivalent. Equivalency determined by written and performance exams. For college credit, enroll in Gavilan's AH 171.

Room	Instructor	Day	Time
HOB114	D Comella-Hilde	TWR	0100-0430

ROP Computer Applications

Computer Literacy - MS Office

An introduction to terminology, design, operation for the novice user. Student will gain experience using the Internet for searches and email. They will complete projects using various software including word processing, spreadsheets, database, presentation graphics, and integration. This course has the option of a letter grade or pass/no pass. ADVISORY: Eligible for English 250 and English 260; completion of CSIS 122. For college credit, enroll in Gavilan's CSIS 1.

Room	Instructor	Day	Time
BU111	S Gaffney	MW	0900-1105

02/02/11 - 03/23/11

Room	Instructor	Day	Time
BU111	S Gaffney	MW	0900-1105

03/28/11 - 05/18/11

Room	Instructor	Day	Time
BU110	S Gaffney	T	0600-0905

03/01/11 - 05/17/11

CSIS 121 Spreadsheet - MS Excel

Introduction to the computer spreadsheet software. A hands-on approach to learning terms, commands, and applications of a spreadsheet program. This course will help prepare students for taking the Excel MOUS (Microsoft Office User Specialist) exams. This course has the option of a letter grade or pass/no pass. May be repeated once for credit when the software changes. Also listed as ACCT 121. ADVISORY: CSIS 1 or CSIS 2 or equivalent computer experience. For college credit, enroll in Gavilan's CSIS 121

Room	Instructor	Day	Time
HOL3	F Mendez	W	0600-0905

03/09/11 - 05/25/11 Above class meets at the Hollister Briggs site.



Short-term Training Program

ROP Dental Assisting

Call the ROP Main Office at
(408) 842-0361
for more information.

Location: ROP-South, 700 West 6th Street, Ste. M, Gilroy

Online Registration ONLY: Begins Tuesday, January 11, 2011 at 8:00 am
Follow link from <http://sccoe.org/depts/scrop/>

Class dates and times:

January 31 - June 24
Mon-Fri, 9:30 am - 3:00 pm

Payment accepted: cash, check, MasterCard and Visa
Students who have a check returned for insufficient funds will be dropped from the class.
No refunds

Cost:

Textbook: Modern Dental Assisting 9th Ed 80.00
Course Fee 595.00
Total Cost of program: \$ 675.00

This course includes instruction in chairside assisting as well as x-ray certification.

Word Processing - MS Word

This introductory course for word processing with Windows is designed for business and non-business majors. Students will develop word processing skills to create a document, select and edit text, move and copy text, use the spelling, grammar, and thesaurus features, format text, and create headers and footnotes for a research paper. This course has the option of a letter grade or pass/no pass and may be repeated for credit when the software changes. ADVISORY: Eligible for English 260 and basic keyboarding skills. For college credit, enroll in Gavilan's CSIS 126.

Room	Instructor	Day	Time
MHG5	F Mendez	F	0900-1235
02/04/11 - 04/22/11 Above class meets at Morgan Hill Community site.			
HOL3	F Mendez	M	0600-0935
02/07/11 - 04/18/11 Above class meets at the Hollister Briggs site.			

Presentation Graphics-MS PowerPoint

This introductory course in presentation graphics will use Microsoft Office's "PowerPoint" software to create a computerized presentation (slide show) with text and objects. This course is also listed as CMUN 129. This course has the option of a letter grade or pass/no pass. May be repeated three times for credit. ADVISORY: CSIS 126 or word processing skills in the Windows environment. For college credit, enroll in Gavilan's CSIS 129 or CMUN 129.

Room	Instructor	Day	Time
HOL3	F Mendez	W	0600-0945
02/02/11 - 03/02/11 Above class meets at the Hollister Briggs site.			

Classroom Locations: Refer to "How to Use This Schedule" on page 5.

ROP Computer Graphics Applications

2D/3D Technical Computer Graphics II

Intermediate computer graphics design course expands skills and concepts introduced in CGD 2. Develops design and graphic skills required to create, explain, model, render, and animate products using a problem solving process and knowledge of ergonomics, materials, design principles and color theories. Projects assigned integrate technology with design and focus upon creating, developing and marketing useful products by developing and visually communicating ideas that are necessary for succeeding in desired design career(s). May be repeated once for credit. ADVISORY: Completion of CGD 2 with a grade of C or better. For college credit, enroll in Gavilan's CGD 4.

Room	Instructor	Day	Time
L1126	C McLaughlin	TR	0220-0340

Advanced Computer Graphics for Design Application II

Advanced computer graphics and design course that combines technical computer graphic skills with interdisciplinary design proficiencies including creating computer imagery, transformations, and rendering to create 3D model using geometric primitives, projections for computer animation and data visualization. Includes structural analysis and emphasis on developing products that include ergonomic features and sustainable materials. Work within electronic portfolio demonstrates skills and knowledge of technical graphic design to visualize, develop and present products to meet societal needs. ADVISORY: Satisfactory score on the English placement exam or a grade C or better in English 250, completion of Mathematics 233 or satisfactory Mathematics placement. Completion of CGD 2 and CGD 8 with a grade of C or better. Computer lab work can be done both in lab and off-site. For college credit, enroll in CGD 9.

Room	Instructor	Day	Time
L1126	C McLaughlin	TR	0220-0340

Introduction to Environmental Design

Transferable: CSU

Develops skills and computer aided design (CAD) skills necessary for designing and producing a set of plans for an array of environmental projects, such as residential remodels, landscape projects, interior design and other small construction projects. Includes introduction to building codes, sustainable design concepts, specifications and other architectural construction document basics necessary for getting permits and entering environmental design careers. For college credit, enroll in Gavilan's CGD 30.

Room	Instructor	Day	Time
L1126	C McLaughlin	TR	1250-0210

ROP Nursing Assistant

Fundamentals of Nursing-Convalescent

A course to provide a basic introduction to patient care in the convalescent setting. Emphasizes principles, understanding and skills necessary to perform basic nursing procedures safely and effectively. Includes introduction to health care, planning, safety, infection control, personal care, basic procedures, rehabilitation, nutrition and clients' rights and needs. At the completion of this course students will qualify for state certification as a nursing assistant. PRE-REQUISITE: Eligible for English 250 and English 260. Clearance from the Department of Health Services (Form HS283), fingerprint card, and health clearance required prior to clinical placement. Health and fingerprint clearance required prior to clinical placement. Uniform, shoes, watch, and stethoscope required. Clinical in Morgan Hill or Hollister, as assigned. For college credit, enroll in Gavilan's AH 180.

Room	Instructor	Day	Time
HOB114	M Machado	W	0630-0130
		MT	0900-1200
HOB114	M Machado	R	0630-0130
		MT	0900-1200
HOB114	D Reid	F	0630-0130
HOB114	M Machado	MT	0900-1200

**Course-to-Course Articulation Agreements
for High School Students**

Gavilan College and District High Schools

HIGH SCHOOL COURSE	GAVILAN COLLEGE	GRADE CRITERIA
ANN SOBRATO HIGH SCHOOL		
Advanced Multi-Media	ART 113, CSIS 113, DM 113	B
Visual Communications	ART 107, CSIS 107, DM 107	B
ANZAR HIGH SCHOOL (Aromas-San Juan Bautista)		
Algebra	MATH 205	A or B
Advanced Algebra	MATH 233	A or B
Computer Bus. Apps.	CSIS 1	B
CENTRAL HIGH SCHOOL (Continuation High School - Morgan Hill)		
Computer Business Applications	CSIS 1 & CSIS 126	C
GILROY HIGH SCHOOL		
Administration of Justice	AJ 10	B
Advanced Drawing & Painting	ART 3A	B
Business and Marketing	BUS 1	C
Computer Business Applications	CSIS 1	B
Computer Business Applications	CSIS 122	B
Marketing & Merchandising	BUS 1	B
Integrated Algebra 1 & 2	MATH 205	A or B
Integrated Algebra 2 & 3	MATH 233	A or B
Visual Communications	DM 77, ART 77, CSIS 77	B
LIVE OAK HIGH SCHOOL (Morgan Hill)		
Advanced Multi-Media	ART 113, CSIS 113, DM 113	B
Algebra I	MATH 205	A or B
Algebra II	MATH 233	A or B
Careers with Children	CD 1, CD 21	A or B
Graphic Technology	ART 77, CSIS 77, DM 77	B
Visual Communications	ART 107, CSIS 107, DM 107	B
MT. MADONNA HIGH SCHOOL (Continuation High School – Gilroy)		
Algebra I	Math 205	A or B
SAN ANDREAS HIGH SCHOOL (Continuation High School – Hollister)		
Computer Business Applications	CSIS 1	B
SAN BENITO HIGH SCHOOL (Hollister)		
Advanced Multi-Media	ART 113, CSIS 113, DM 113	B
Architectural Design	CGD 30	B
Algebra 1A or Algebra II	MATH 205	A or B
Algebra 2A	MATH 233	A or B
Business and Marketing	BUS 1	C
Careers with Children/ROP	CD 1, CD 21	B
Commercial Art	ART 3A	B
Computer Aided Drafting/C.A.D.	CGD 2	B
Computer Business Applications	CSIS 1	C
Computer Hardware Repair	CSIS 181	B
Marketing	BUS 1	B
Technical Writing	JOUR 18A	B

**Additional
ROP
sites in the
Gavilan College
District**

All day classes offered at high school locations are part of the regular high school schedule. Adults are admitted on a space-available basis by contacting the high schools.

**ROP Instructional Services
Gilroy - 408-842-0361**
Dental Assisting

**Ann Sobrato High School
408-201-6200**
Advanced Multi-Media
Agriculture Construction
Art & History of Floral Design
Commercial Advanced Photography
Commercial Art
Environmental Horticulture
Graphic Design
Veterinary Science
Visual Communications (Digital Media)

**Anzar High School
408-623-7660**
Audio Video Publishing/Multi-Media
Photography

**Central Continuation High School
408-201-6300**
Computer Business Applications

**Christopher High School
408-843-4124**
Digital Design & Animation I & II
Professional Dance

**Gilroy High School
408-847-2424**
Advanced Auto Technology
Art & History of Floral Design
Biotechnology
Culinary Arts
Commercial Photography
Computer Business Applications
Criminal Justice
Marketing & Merchandising
Sports Medicine I & II
Veterinary Science

**Live Oak High School
408-201-6129 or 408-201-6111**
Advanced Multi-Media
Art & History of Floral Design
Cabinetmaking
Construction Technology
Fashion Design
General Merchandising & Marketing
Graphics Technology
Veterinary Science
Visual Communication (Digital Media)

**San Andreas High School
831-637-9269**
Computer Bus. Applications

**San Benito High School
831-637-5831, ext. 185**
Advanced Art AP
Advanced Multi-Media
Ag. Fabrication-Construction
Architectural Design
Art Metal Design
Auto Mechanics
Cabinet Making
Careers w/Children
Child Development/Vocational
Commercial Art
Computer Aided Drafting/C.A.D.
Computer Applications
Computer Maintenance
Floriculture
Food Service/Restaurant Careers
Metals Fabrication
Sales Marketing
Sports Medicine
Technical Writing
Wood Sculpture/Design

Check out

- Classes and services offered at the satellite sites...
Hollister classes... pages 86-87 Morgan Hill classes... pages 88-89
- Late-Start/Short-Term Classes... page 90
- Online/Hybrid Classes... pages 84-85

Summer Session 2011 PREVIEW

June 13 - July 22

Look for the **Summer Session Registration Schedule**
in the GAVILAN COLLEGE SUMMER/FALL SCHEDULE OF CLASSES.
Look for it in your mailbox and online at www.gavilan.edu in early MAY.

Summer Session calendar dates subject to change. Check the Summer Calendar in the Gavilan College Summer/Fall 2011 Schedule of Classes.

CHILD DEVELOPMENT

- CD 2 Early Child Development
- CD 3 Child Growth and Development During the School Years
- CD 19 Introduction to Careers with Children
- CD 25A Art Methods
- CD 25B Art Methods
- CD 28A Child Dev & Guidance for Family Child Care/Foster Care
- CD 28B Dev Learning Activities for Family Child Care & Foster Care
- CD 28C Administering a Family Child Care Home

COMMUNICATION STUDIES

- CMUN 1A Introduction to Public Speaking
- CMUN 10 Small Group Communication
- CMUN 129 Presentation Graphics - MS PowerPoint

COMPUTER SCIENCE & INFORMATION SYSTEMS (CSIS)

- CSIS 1 Computer Literacy - MS Office
- CSIS 3 Research Skills
- CSIS 6 Web Page Authoring I
- CSIS 7 Web Page Authoring II
- CSIS 10 BASIC Programming
- CSIS 24 Java Programming I
- CSIS 45 C++ Programming I
- CSIS 78 Web Sites with SQL and PHP
- CSIS 84 Javascript Programming
- CSIS 85 Web Design I: Dreamweaver
- CSIS 108 Digital Media Lab
- CSIS 122 Computer Keyboarding

ADMINISTRATION OF JUSTICE

- AJ 10 Introduction to the Administration of Justice

ALLIED HEALTH

- AH 11 Nutrition

ANTHROPOLOGY

- ANTH 1 Introduction to Physical Anthropology
- ANTH 3 Introduction to Cultural Anthropology

ART

- ART 3A Drawing and Composition
- ART 6 Art Appreciation
- ART 10A Cultural History of Ceramics
- ART 10B Ceramics
- ART 23 Independent Study
- ART 25A Art Methods
- ART 25B Art Methods
- ART 108 Digital Media Lab

AVIATION MAINTENANCE TECHNOLOGY

- AMT 123 Independent Study

BIOLOGICAL SCIENCE

- BIO 10 Principles of Biology
- BIO 11 Nutrition
- BIO 15 Survey of Human Anatomy and Physiology

BUSINESS OFFICE TECHNOLOGY

- BOT 112 Business Computations with Machines

BUSINESS

- BUS 1 Fundamentals of Business

CHEMISTRY

- CHEM 30A Elementary Chemistry

continued



**Hands on Acting!
Kids on Stage!
Since 1985!**

Enroll Now!

By Phone: 408-612-2057
Online: www.gavilan.edu/star
Email: stargav@gavilan.edu

Ask about before and after care and carpool connections.
Sessions are subject to availability of the play and minimum enrollment.

Marilyn Abad-Cardinali, Founder/Executive Director



STAR GILROY

Theatre Performing Arts Day Camp for ages 8 to 16
June 20 - July 15, Monday - Friday, 9 am - 4 pm
Performances: July 15 at 7 pm & July 16 at 4 pm
Gavilan College Theater, main campus
4 Weeks - Only \$595

STAR VIDEO

Television Production Day Camp for for ages 10 to 16
June 20 - July 8, Monday - Friday, 9 am - 4 pm
Gavilan College TV Studio, main campus
3 Weeks - Only \$450

STAR SAN JUAN BAUTISTA

Theatre Performing Arts Day Camp for ages 8 to 16
July 19 - August 5, Monday - Friday, 9 am - 4 pm
Performances: August 5 & 6 at 7 pm
El Teatro Campesino Playhouse
3 Weeks - Only \$300

CSIS CONTINUED

- CSIS 124 Windows Fundamentals
- CSIS 126 Word Processing - MS Word
- CSIS 129 Presentation Graphics - MS PowerPoint
- CSIS 570 Computer Access Evaluation
- CSIS 571 Computer Assisted Instruction

COSMETOLOGY

- COS 207 Contemporary Styling
- COS 223 Independent Study

DIGITAL MEDIA

- DM 6 Web Page Authoring I
- DM 7 Web Page Authoring II
- DM 85 Web Design I: Dreamweaver
- DM 108 Digital Media Lab

ENGLISH

- ENGL 1A Composition
- ENGL 1B Composition and Literature
- ENGL 1C Critical Reasoning and Writing
- ENGL 250 Practical Writing
- ENGL 260 Preparation for College Reading
- ENGL 420 Reading Improvement
- ENGL 440 Basic Writing

ENGLISH AS A SECOND LANGUAGE

- ESL 502B Survival ESL II Second Half
- ESL 582 ESL Pronunciation II
- ESL 584 Culture Through Film

GEOLOGY

- GEOL 1 Introduction to Geology

GUIDANCE

- GUID 1 Self-Assessment and Career Development
- GUID 6 Life Skills for Higher Education
- GUID 22 Field Work and Service

HEALTH EDUCATION

- HE 1 Health Education

HISTORY

- HIST 2 United States History Reconstruction to the Present

LIBRARY

- LIB 3 Research Skills
- LIB 6 Web Page Authoring I

MATHEMATICS

- MATH 5 Introduction to Statistics
- MATH 8B Second Half of Precalculus
- MATH 205 Elementary Algebra
- MATH 205A First Half of Algebra
- MATH 205B Second Half of Algebra
- MATH 208 Plane Geometry
- MATH 233 Intermediate Algebra
- MATH 233A First Half of Intermediate Algebra
- MATH 233B Second Half of Intermediate Algebra
- MATH 402 Pre-Algebra
- MATH 414 Basic Math Skills

Watch for it!

Get ready for your fall classes by attending a

MATH BOOT CAMP!

Whether you are a student who needs more practice in understanding foundational elements of math such as fractions, percents, signed numbers and/or word problems or you just need a brush up on the basics, Math 414 is for you. This course is a one week, nine hour a day, math boot camp, where students will develop or redevelop a solid understanding of basic math concepts.



PHYSICAL EDUCATION: ACADEMIC

- PE 1 Orientation for Student-Athlete Success

PHYSICAL EDUCATION: ACTIVITIES

- PE 16 Swimming
- PE 21 Volleyball
- PE 25 Soccer
- PE 27 Basketball
- PE 37 Softball
- PE 46 Agility and Motor Development
- PE 61 Swim for Fitness
- PE 62 Yoga
- PE 65 Baseball
- PE 70 Pilates
- PE 75 Sports Conditioning

continued

SUMMER SPORTS CAMPS FOR KIDS!

Call 852-2801 for details.



**Study and travel this summer!
Learn Spanish in Spain!**

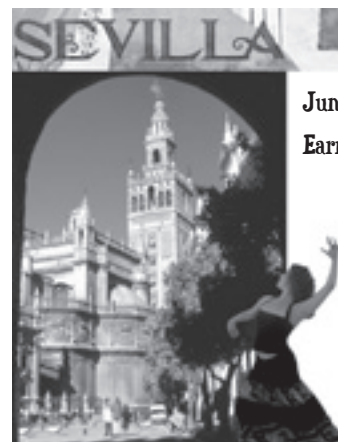

June 2- July 1
Earn up to 5 units

Study the language and culture while living with a host family in Seville, Spain

Cost: Approximately \$1,500 plus airfare for a 4-week program.

Attend the Orientation:
Saturday, Feb 19 at 9:30 am
in HUM 105 on the Gilroy main campus.

For more information, visit the website at www.gavilan.edu/spanish, call Albert Marques at (408) 848-4794 or email amarques@gavilan.edu



Short term, Not-for-Credit Classes



Watch for our 2011 CFY classes.

Courses include math, science, study skills, media, sports and much more!

For specific course offerings, visit our website at www.gavilan.edu/ce and click on 'courses'.

Classes start monthly!

CFY Teaching

Do you have an idea for a CFY class? Join our CFY team by visiting our website at www.gavilan.edu/ce and click on the 'teaching' link or call us at (408) 852-2802.

PHYSICAL EDUCATION: ADAPTED

APE 34	Adapted Aquatic Exercise
APE 36	Adapted Physical Education
APE 534	Adapted Aquatic Exercise
APE 536	Adapted Physical Education

POLITICAL SCIENCE

POLS 1	Introduction to American Government
--------	-------------------------------------

PSYCHOLOGY

PSYC 1A	Introduction to Psychology
PSYC 2	Early Child Development
PSYC 3	Child Growth and Development During the School Years
PSYC 5	Self-Assessment and Career Development

REAL ESTATE

RE 165	Legal Aspects of Real Estate
--------	------------------------------

SOCIOLOGY

SOC 1A	Introduction to Sociology
--------	---------------------------

SPANISH

SPAN 1A	Elementary Spanish
SPAN 1B	Elementary Spanish
SPAN 2A	Intermediate Spanish
SPAN 2B	Intermediate Spanish
SPAN 8A	Conversational Spanish
SPAN 8B	Conversational Spanish
SPAN 8C	Conversational Spanish
SPAN 8D	Conversational Spanish
SPAN 12A	Spanish for Spanish Speakers
SPAN 23	Independent Study
SPAN 98	Special Topics

HEATRE ARTS / DRAMA

THEA 23	Independent Study
---------	-------------------

VOCATIONAL PREPARATION FOR DISABLED

AE 600	Vocational Training I
AE 602	Vocational Training III
AE 636	Adapted Physical Education

NONCREDIT SUMMER CLASS

AH 793	Personal and Career Development
--------	---------------------------------

Información en Español



ESL (English as a Second Language)

New students who want to take ESL classes at the Gilroy campus will register at the Admissions

& Records Office for a placement assessment appointment when completing an application. Call 408-848-4737 or 408-848-4751 to make an appointment or come into Admissions & Records at the Gilroy main campus.

Students interested in taking ESL courses in Hollister should register and take the placement test at the Briggs Building in Hollister.

Who Should Take the ESL Assessment?

- Students who do not know any English.
- Students who know some English but have not received formal classes in the English language or who took ESL classes more than three years ago.
- Students who attended high school in this country for less than a year.
- Students who attended high school in this country for a few years but are unsure about their level of proficiency in English.

Placement Assessment and Orientation for ESL Applicants

Students who want to enroll in ESL classes must:

- Complete a Gavilan College application at Admissions & Records or at the sites.
- Sign up for a testing appointment at Admissions & Records (Gilroy).
- Return for testing, which includes oral and written exams.

The interview information and the test results will be used to advise and place students into the ESL classes that best match their needs. Students will be ready to register for ESL classes at the end of this three-hour placement assessment appointment.

Orientation for new ESL students will be offered several times during the first two weeks of the semester and will be given in English and Spanish in the classroom setting. New students will be contacted for orientation by their ESL instructors.

Vaya a las página 58 para ver la Vista de Clases de ESL.

ESL (Inglés como Segundo Idioma)

Los nuevos estudiantes que deseen tomar clases de Inglés como Segundo Idioma (ESL) en Gilroy deben inscribirse en la Oficina de Admisiones y Archivos para hacer una cita y tomar la evaluación apropiada después de llenar una solicitud. Llame 408-848-4737 o 408-848-4751 hacer una cita o venga a la Oficina de Admisiones y Archivos en Gilroy.

Para aquellos estudiantes que desean estudiar en Hollister, deben hacer una cita para tomar el examen de nivelación en la oficina en Hollister en el Briggs Building.

¿Quién debería tomar el examen de evaluación de ESL?

- Los estudiantes que no saben nada de inglés.
- Los estudiantes que saben un poco de inglés pero que no han tomado clases formalmente o que tomaron clases hace más de tres años.
- Los estudiantes que asistieron a la secundaria (high school) en este país por menos de un año.
- Los estudiantes que asistieron a la secundaria (high school) en este país por algunos años pero que no están seguros de su nivel de proficiencia en el inglés.

Asesoramiento, Colocación y Orientación para Estudiantes ESL

Los estudiantes que deseen inscribirse en clases de ESL (Inglés como Segundo Idioma) deben hacer lo siguiente:

- Completar una solicitud de admisión en la Oficina de Admisiones y Archivos.
- Obtener una cita para el examen de nivelación en la Oficina de Admisiones y Archivos (Gilroy).
- Presentarse al examen de nivelación de acuerdo con la cita obtenida para tomar el examen escrito y oral.

Los resultados del examen y la información de la entrevista serán usados para recomendar y colocar a los estudiantes en las clases de Inglés como Segundo Idioma (ESL) que mejor les convengan. Los estudiantes estarán listos para inscribirse en las clases adecuadas al final de esta evaluación de tres horas. Los nuevos estudiantes en el Programa de Inglés como Segundo Idioma (ESL) recibirán una orientación sobre los servicios y regulaciones del Colegio Gavilán en sesiones ofrecidas durante las primeras dos semanas del semestre. Las orientaciones serán dadas en inglés y en español y los maestros se comunicarán con los nuevos estudiantes para asistirlos en seleccionar la sesión más conveniente.

NUESTRA MISIÓN En un ambiente que cultiva la creatividad, estimula la curiosidad y hace énfasis en el aprendizaje del estudiante, Gavilán College sirve a su comunidad, ofreciendo servicios de gran calidad y apoyo, que preparan a los estudiantes para carreras de transferencia a la universidad o técnicas y de servicio público, educación para toda la vida y la participación en una sociedad global y diversa.

POLIZAS Y PROCEDIMIENTOS Pendiente a la Mesa Directiva. La Política y Procedimientos del Colegio están disponibles a través de acceder la página de Internet del Colegio Gavilan en www.gavilan.edu (Seleccione el "College Catalog" bajo el menú de "Academics".) o visitando la Oficina del Vicepresidente de Servicios Estudiantiles (SC128).

Formas Alternativas El Catalogo y el Horario de Clases del Colegio Gavilán está disponible en formato de medios alternos. Por favor de contactar El Centro de Recursos para Discapacitados (DRC) en (408) 848-4865 o la Oficina del Vicepresidente de Servicios de Estudiante en (408) 848-4738.

Servicios para los Estudiantes con Incapacidades

Los estudiantes que requieren servicios o arreglos especiales debido a incapacidades auditivas, visuales o alguna otra incapacidad verificado deberán ponerse en contacto con su instructor, consejero, asesor El Centro de Recursos para Discapacitados (DRC).

Discriminación

NO DISCRIMINACIÓN El Distrito está comprometido a proveer igualdad de oportunidades en programas educativos, empleo, y acceso a programas y actividades de la institución.

PROHIBICIÓN DE ABUSO Y OFENSAS POR DISCRIMINACIÓN

Referencia: Secciones 212.5; 66252; 66281.5 del Código Educativo

El Distrito está comprometido a proveer un ambiente de enseñanza y de trabajo que respete la dignidad de los individuos y grupos. El Distrito estará libre de ofensa y persecución sexual y todas la formas de intimidación sexual y abuso. También estará libre de otros abusos y ofensas por discriminación incluyendo aquellas ofensas basadas en cualquiera de los siguientes estados: raza, religión, ancestro, origen, impedimento, sexo (género), orientación sexual, o la percepción de que una persona tenga alguna de las características mencionadas.

TÍTULO VI, TÍTULO IX, Y NORTEAMERICANOS CON IMPEDIMENTO/SECCIÓN 504/508 Para presentar una queja en cualquiera de las siguientes areas, por favor comuníquese con el Oficial de Igualdad de Oportunidades, Joseph D. Keeler, Vicepresidente de Servicios Administrativos, HR 101 (408-848-4731) o

Jim Bowers, el Director de Recursos Humanos, HR103 (408-848-4753).

Las areas son las siguientes: quejas por violación de derechos civiles (Título VI), quejas por violación de igualdad de género, discriminación sexual, o abuso (Título IX) y quejas por violación contra personas con impedimentos (ADA/Sección 504/508)

Cumplimiento de ADA Si usted tiene un impedimento verificado y necesita materiales o servicios de estudio en un formato alterno, contacte El Centro de Recursos para Discapacitados (DRC) o al Vicepresidente de Servicios Educativos para obtener ayuda. Hay servicios para estudiantes con impedimentos verificados a través de DRC o a través del Vicepresidente de Servicios Educativos.

Derechos Educativos y Privacidad

Gavilan College está en cumplimiento de los Derechos Educativos Federales y Acto de 1974 (también llamado el Buckley Amendment) y las regulaciones del Título V de California (SB 182). Las siguientes reglas están en efecto:

1. Toda la documentación académica, documentación relacionada con problemas disciplinarios, y cualquiera otra documentación oficial es mantenida para todos los estudiantes que han solicitado admisión a Gavilan College.
2. La documentación oficial es mantenida por y localizada en la Oficina de Admisiones y Registros.
3. La documentación oficial será proveida únicamente cuando la solicitud o permiso sea hecha por escrito por parte del estudiante previo pago de cualquier cargo o costo a la institución, excepto en los casos provistos en ley.
4. La siguiente información puede ser proveida por Gavilan College sin consentimiento escrito por parte del estudiante:
 - a. el nombre del estudiante
 - b. las fechas de matriculación/asistencia a Gavilan College
 - c. la fecha de graduación y título o certificado recibido

La entrega de cualquier otra información requerirá consentimiento escrito del estudiante, excepto en los casos previstos en ley. Los estudiantes pueden notificar su deseo por escrito a la Oficina de Admisiones y Registros durante la primera semana de cada sesión de estudios que no desean que los puntos ennumerados en a), b) y c) pueden ser entregados.
5. Los estudiantes tienen derecho a revisar sus propios archivos y la documentación que esté en ellos. Cualquier objeción a éstos archivos debe ser presentada por escrito al Vicepresidente de Instrucción y Servicios al Estudiante. Las objeciones serán resueltas por dicho vicepresidente, y la resolución será inserta en el archivo del estudiante pero no entregada con el resto de la documentación. En caso de desacuerdo sobre éste punto, la Política de Quejas de la institución estará en efecto.

VISTA DE CLASES DE INGLES COMO SEGUNDO IDIOMA (ESL)

SIN CREDITO

HABILIDADES PARA VIVIR		VOCACIONALES	
ESL 777	ESL 778	VESL	ESL 704A/B
ESL 779	ESL 780	Para progresar de clases de ESL, el estudiante deberá tomar el asesoramiento de ESL.	
ESL 781	ESL 782		

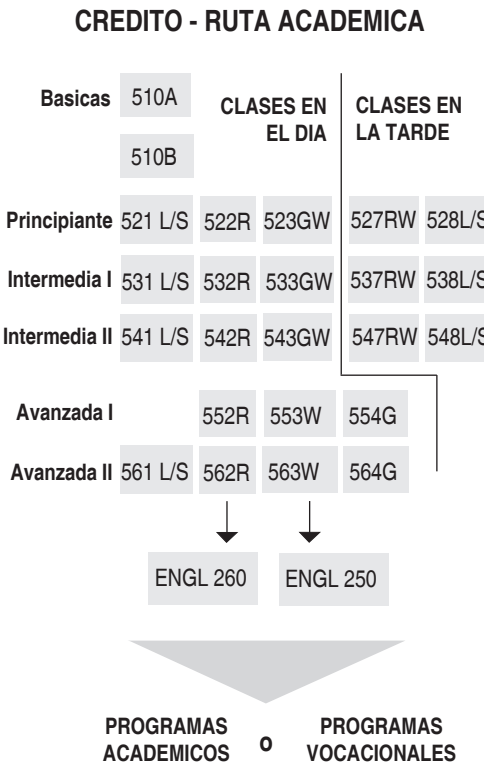

CLASES SUPLEMENTALES DE ESL:

ESL 546	Intro Computers/ESL
ESL 556	Intro Competency/ESL
ESL 581	Pronunciation I
ESL 582	Pronunciation II
ESL 584	Culture through Film
ESL 585	Editing for ESL Writers

Copias de las regulaciones federales y estatales y del Proceso de Resolución de Problemas Estudiantiles son disponibles a través de la Oficina de Admisiones y Registros y pueden ser revisadas por los estudiantes haciendo una cita con el Vicepresidente de Instrucción y Servicios Estudiantiles o el Director de Admisiones y Registros. El Proceso de Resolución de Problemas Estudiantiles también está disponible en éste catálogo, online, y en el Manual Estudiantil.

Habilidad en Inglés para Estudios Vocacionales

Habilidad limitada en Inglés no será obstáculo para ser admitido y participante en programas educativos vocacionales.

SERVICIOS ESTUDIANTILES Y PROGRAMAS DE APOYO PARA LA INSTRUCCIÓN

Servicios de Asesoría Inscribirse y tener éxito en clases a nivel post-secundario requieren dedicación y tiempo. A veces ocurren problemas personales y familiares que distraen a los estudiantes de sus tareas y clases y en estos casos, la única solución parece ser abandonar los estudios. Antes de tomar esta decisión tan difícil, por favor consulte a un consejero. Una buena plática puede ayudar a poner la situación en perspectiva, identificar posibles soluciones, y dar el apoyo necesario para hacer modificaciones necesarias en el horario y las clases. Gavilán College provee consejeros que hablan español y las citas con ellos pueden ser hechas para el día o para la tarde. No hay que pagar por este servicio. Para más información o para hacer una cita con un consejero, visite la Oficina de Consejeros, localizada en el cuarto número SC 113 en el Centro de Estudiantes (Student Center) o visite www.gavilan.edu/counsel.

Centro de Desarrollo de Niños El Centro de Desarrollo de Niños provee cuidado para niños de dos a cinco años de edad. Este programa es para familias con ingresos mensuales que satisfacen el criterio de elegibilidad. Estos programas sirven a niños con discapacidades y necesidades especiales y que no hablan inglés. Todos los programas requieren que los padres inviertan ciertas horas como voluntarios.

El Centro de Recursos para Discapacitados (DRC) ofrece asesoría individual para evaluar las destrezas de los estudiantes en las áreas de lectura, matemáticas, escritura, razonamiento, lenguaje oral, percepción y memoria. Los estudiantes que requieren servicios o arreglos especiales debido a incapacidades auditivas, visuales o alguna otra incapacidad deberán ponerse en contacto con su instructor, consejero, asesor o la oficina del DRC.

SERVICIOS DE AYUDA ECONÓMICA PARA EL COLEGIO

La ayuda económica para costos del colegio, están disponibles para estudiantes de cualquier tipo de ingreso.

OFICINA DE AYUDA ECONÓMICA

www.gavilan.edu/finaid/

Oficina SC 124

Abierto: lunes-jueves: 8 am a 5 pm
viernes: Cerrado al público.

Horario de la Tarde: Las horas son extendidas de 5 a 7 pm durante el período de matriculación.

CÓDIGO ESCOLAR DEL COLEGIO GAVILÁN ES:
001202

El colegio Gavilán participa en varios programas de ayuda económica, que están diseñados para proporcionar ayuda a los estudiantes de necesidad económica. Esta ayuda es proporcionada por diferentes instituciones incluyendo agencias federales, estatales y privadas.

Si está interesado en solicitar ayuda económica, adquiera una solicitud (FAFSA) en la oficina SC 124 o solicítela usando el Internet en la página www.fafsa.ed.gov. Si llena la solicitud usando el Internet, imprima y mande la página con su firma (signature page) o use su número secreto (PIN) para firmar la solicitud electrónicamente. Si desea aplicar para obtener su número secreto (PIN) ingrese a www.PIN.ed.gov. Las solicitudes también se pueden obtener por medio de los Consejeros de las Preparatorias (High School), Centro de Carreras de la Preparatoria y Bibliotecas Públicas.

Los requisitos para ayuda económica de parte de FAFSA son:

- Tienen que comprobar que necesitan ayuda económica y que cumplen con las reglas de cada programa.
- Tienen que ser ciudadanos, o ser residentes permanentes de los EE.UU.
- Tienen que tener buen historial en préstamos estudiantiles, y no deber nada a la oficina de ayuda económica.
- Tienen que ser elegibles para recibir los beneficios de una educación superior.
- Hombres entre 18 y 25 años de edad tienen que registrarse en el servicio selectivo (militar).

NOTA: Si ha estado encarcelado por usar o vender drogas ilegales, puede ser no elegible para algunos programas de ayuda económica.

PÓLIZA DE PROGRESO SATISFACTORIO ACADÉMICO (SAP) La oficina de ayuda económica requiere medir su progreso académico hacia un certificado, asociado, o un programa de transferencia

a la universidad. Si sus metas no son uno de estos programas, no califica para ayuda económica. Su progreso será evaluado por lo mínimo una vez por año. Si ustedes han tenido circunstancias extenuantes durante su último término en el Colegio Gavilán y fueron colocados en descalificación, podrán someter una Apelación y un Cuestionario SAP para su consideración.

PROGRAMAS DE AYUDA ECONÓMICA Ayuda

Pagando la Matriculación: El programa (Board of Governor's Fee Waiver/BOG), ayuda a pagar parte de la matriculación. Solamente para residentes de California. Es para estudiantes de bajo ingreso familiar. La solicitud para el BOG se encuentra en la página de Internet en: www.gavilan.edu/finaid/

Becas Gratuitas Federales y Estatales:

Federal Pell Grant • Federal SEO Grant • Federal Work Study Grant • Cal Grant • Chafee Grant • Child Development Grant

Becas Federales de Trabajo y Estudio: Proporcionan a los estudiantes de Gavilán Collage empleos temporales mientras obtienen valiosa experiencia laboral. Para ser considerados para el programa de trabajo y estudio federal, se requiere que los estudiantes llenen la solicitud de FAFSA 2010-2011 FAFSA, que indiquen que están interesados en el Programa de Trabajo y Estudio en la pregunta 31 de FAFSA, que alcancen los requisitos del programa y que reciban ayuda financiera. Puesto que los fondos para el programa Federal de Trabajo y Estudio son limitados, se sugiere que los estudiantes sometan su solicitud FAFSA 2010-11.

Becas: Las becas son otorgadas en base al aprovechamiento académica y/o la necesidad financiera. La elegibilidad varía y se establece dependiendo del donador de dicha beca. Las solicitudes para becas privadas las encuentran durante el año en la página de Internet de Ayuda Financiera en www.gavilan.edu/finaid. Les recomendamos que busquen becas en línea varias veces durante el semestre. Durante el ciclo escolar se anuncian becas en cuanto están disponibles.

Servicios Para Miembros de las Fuerzas Armadas

(Veteranos): Colegio Gavilán ofrece asistencia especial a estudiantes que son veteranos o hijos de veteranos deshabilitados que asisten al colegio, para lograr una meta. Estudiantes que tengan preguntas sobre si califican, beneficios y el procedimiento de las solicitudes o cualquier otra inquietud sobre veteranos, por favor de contactar la oficina de ayuda económica al 408-848-4734.

Préstamos Estudiantiles Federales: Colegio Gavilán participa en el Federal Direct Loan Program. Préstamos estudiantiles federales, ofrecen un interés bajo y planes de pago flexibles. Si están interesados en solicitar un préstamo complete la FAFSA y atienda al taller de consejería de préstamo. Solicitudes para el préstamo serán distribuidas en el taller de consejería.

Becas Privadas: Becas privadas son fundadas por organizaciones y agencias privadas. Estos fondos se otorgan al estudiante dependiendo de las notas académicas o dependiendo de la necesidad económica del estudiante. Para ser considerado para una beca privada, el estudiante necesita completar una solicitud por cada beca privada a la que se aplique. Visite nuestra oficina para más información.

Solicitudes para la beca privada llamada "Gavilan College Scholarship Application" están disponibles en nuestra oficina.

NECESITA AYUDA FINANCIERA PERO NO TIENE DIPLOMA DE ESCUELA SECUNDARIA (HIGH SCHOOL)?

Regulaciones federales requieren a aquellos estudiantes que no poseen un diploma de escuela secundaria (high school), certificado de Desarrollo de Educación General (GED), o Examen de Proficiencia de High School de California (CHSPE), y que estén aplicando para ayuda financiera, que tomen un asesoramiento de Habilidad para Beneficiarse. Usted estará exento, si tiene un diploma de escuela secundaria (o algo equivalente) de otro país.

Estudiantes con habilidad limitada en el idioma de Inglés, que estén inscritos en clases de Inglés como Segundo Idioma (ESL) y que no tengan diploma de escuela secundaria o examen de GED, y que estén aplicando para ayuda financiera, deberán de tomar el asesoramiento de Habilidades del idioma Inglés Combinado (CELSA). El examen CELSA es ofrecido una vez al mes. Por favor llame a la Oficina de Ayuda Financiera (408-848-4727) para una referencia.

Inscríbase para una sesión de examen a través de la Oficina de Ayuda Financiera: Teléfono 408-848-4727, oficina número SC 124. Las sesiones comienzan puntualmente a la hora anunciada. Para ahorrar tiempo, haga favor de presentarse media hora antes de la hora indicada. Nadie será admitido después de que haya comenzado la sesión.

Para fin de ser admitido en el cuarto de examen, usted deberá proveer una identificación válida* con retrato, número de identificación estudiantil de Gavilán College, una copia de su horario de clases y la nota de referencia de la Oficina de Ayuda Financiera.

Visite la Oficina de Asesoramiento, cuarto MP100, o llame al teléfono 408-846-4992, por lo menos dos días antes de su cita, para confirmar la hora y la localidad de su cita. Hay la posibilidad de que cambien la hora y/o la localidad del examen.

* Una identificación con retrato válida incluye una Licencia de Manejar del Estado de California, identificación de California, pasaporte, Tarjeta de Miembro del Cuerpo Estudiantil (ASB), identificación militar o Tarjeta de Registro de Extranjero. Comuníquese con la Oficina de Asesoramiento, cuarto número MP100, o llame al teléfono 408-846-4992, si no tiene una identificación válida.

PROGRAMA DE NO-CREDITO Clases de No-Crédito son ofrecidas y diseñadas para responder a las necesidades específicas e intereses de aquellos estudiantes que no desean obtener créditos por unidades. Estas clases ofrecen oportunidades para mejorar en materias, crecimiento del desarrollo, poder aprender ocupaciones y para aprender otras áreas de educación general. Estos cursos y programas están definidos categóricamente bajo el Código de Educación, Sección 84711, mientras que los fondos del estado se permiten en nueve categorías específicas.

Programa para Personas Mayores - Este programa ofrece clases de interés especial para adultos mayores de 55 años de edad. La mayoría de nuestras clases se llevarán a cabo en lugares de reuniones de adultos mayores con el fin de promover una inscripción satisfactoria y facilidad para dichos estudiantes.

Programa para el Bienestar del Personal - Este programa está diseñado para responder a las necesidades de los adultos que trabajan. Las clases están abiertas para todos los miembros del personal y de la comunidad.

Programa de Educación Básica Para Adultos - Este programa está diseñado para adultos que desean tomar clases de Inglés como Segundo Idioma (ESL). Ofrecemos clases para preparación de Ciudadanía, clases para mejorar sus habilidades en lectura, escritura, y matemáticas. El programa también ofrece clases para los estudiantes que están interesados en preparación de Educación General (GED) y CAHSEE (Examen de Egreso de las Preparatorias de California).

Todas las clases son gratuitas. No se requieren pruebas, exámenes ni tampoco se otorgan calificaciones. Las inscripciones se realizan a través de la Oficina de Admisiones y Archivos o en el lugar en donde se vaya a impartir la clase, durante la primera sesión de la clase. Los estudiantes deben de contactar directamente a la Oficina de No-Crédito si tienen preguntas o si necesitan más información, favor de llamar al (408) 852-2824.

NUEVO!
Rente un Texto!



Los estudiantes ahora pueden ahorrar 50% o más rentando textos!

Vaya a rent-a-text.com para ver los detalles de la tienda.



EOPS

Programas y Servicios de Oportunidad Adicional

La oficina de Programas y Servicios de Oportunidad Adicional (EOPS) provee apoyo a estudiantes que experimentan desafíos económicos, sociales, y educativos. La intención del programa es asistir a estos estudiantes a alcanzar sus metas educativas incrementando el acceso, la retención, y la transferencia a otras instituciones de enseñanza. Para calificar para el programa de EOPS, los estudiantes deben demostrar necesidad financiera y educativa y matricularse en un mínimo de 12 unidades cada semestre.

Servicios y beneficios disponibles para estudiantes: Conserjería personal y académica, asistencia para la compra de libros, prioridad de inscripción a clases, tutoría, paseos a universidades, talleres de enriquecimiento, becas y mucho más.



CalWORKs sirve a estudiantes quienes reciben asistencia pública para llegar a ser autosuficientes,

a través de ofrecerles educación, empleo y servicios de apoyo. Los programas laborales para los estudiantes de Cal-WORKs, están vinculados a las demandas del mercado laboral y pueden ayudarlos a trabajar en una trayectoria de carrera que los lleve a obtener un ingreso suficiente para poder sostener a sus familias. Los servicios de apoyo que CalWORKs ofrece incluyen el área académica, la personal y asesoría para la carrera, libros de texto, asistencia y colocación de empleo, servicios de apoyo y enlace con los departamentos de servicios sociales del condado.

El personal de CalWORKs es cordial y apoya a los estudiantes para que estos puedan lograr alcanzar sus metas. La oficina se encuentra localizada en L101 A, junto a la biblioteca y está abierta de lunes a viernes de 8 a.m. a 5 p.m. Los estudiantes interesados pueden llamar al 408-848-4813.

Telephone Numbers

Main Campus/Numero Principal	408-848-4800	Distance Education Coordinator/ <i>Coordinador de Educación a Distancia</i>	408 848-4885
from Hollister, call toll free/ <i>desde Hollister llame gratis al</i>	637-1158	EOPS - Extended Opportunity Programs & Services/ <i>Programas y Servicios de Oportunidad Adicional</i>	408-848-4740
Morgan Hill Site/Campus Morgan Hill	408-782-2873	ESL Computer Lab/ <i>Laboratorio de Computadoras para ESL</i>	408-848-4856
Hollister Site , Briggs Building/ <i>Campus Hollister, Edificio Briggs</i>	831-636-3783	Evening Office/ <i>Oficina Nocturna</i>	408-852-2814
Campus Security (non-emergency)/ <i>Seguridad del Campus (no emergencias)</i>		Financial Aid/ <i>Ayuda Financiera</i>	408-848-4727
.	408-848-4703	First Year Experience/ <i>Experiencia del Primer Año</i>	408-848-4701
Emergency: First: Dial '911' (On campus, dial '8' first.)/ <i>Emergencias: Primero marque el 911. (desde el Campus marque primero el "8".)</i>		Foundation/Fundraising/ <i>Fundación/Recaudaciones de Fondos</i>	408-848-4715
Second: Dial '10' for campus emergency support./ <i>Segundo: Marque el '10' para apoyo de emergencias en el campus.</i>		GavTV, Channel 18/ <i>Canal 18</i>	408-848-4764
From campus pay phone: Dial 408-710-7490./ <i>Desde un teléfono público del campus: marque 408-710-7490.</i>		Post-Production/ <i>Poste Producción</i>	408-848-4717
Cell phone: 408-710-7490/ <i>Celular: 408-710-7490</i>		The Gavilan Press/ <i>Periódico "The Gavilan Press"</i>	408-848-4837
		to fax news events/fax para enviar eventos noticiosos	408-848-4827
		GECA - TJ Owens Early College Academy/ <i>Academia de Universidad Temprana GECA TJ Owens</i>	408-846-4909
Admissions & Records/ <i>Oficina de Admisiones y Récor ds</i>	408-848-4735 or 846-4954	Health Services/ <i>Servicios de Salud</i>	408-848-4791
Student Accounts Cashier/ <i>Cajero de las Cuentas del Estudiante</i>	408-852-2840	HOPE Services/ <i>Servicios HOPE</i>	408-846-6946
Transcripts/ <i>Expedientes Académicos</i>	408-848 4733	Human Resources/ <i>Recursos Humanos</i>	408 848 4755
Grading/ <i>Calificaciones</i>	408-848 4751	International Students/ <i>Estudios Internacionales</i>	408-848-4754
Enrollment Verifications/ <i>Verificación de Registro</i>	408-846 4954	Library/ <i>Biblioteca</i>	408-848-4810 or 408-848-4806
Graduation/ <i>Graduación</i>	408-848 4737	Math Lab/ <i>Laboratorio de Matemáticas</i>	408-846-4959
Allied Health/ <i>Aliado en la Salud</i>	408-848-4883	MESA Program - Math, Engineering, Science Achievement/ <i>El Programa de Superación en Matemáticas, Ingeniería y Ciencias</i>	408-846-4968
ASB Advisor/ <i>Asesor ASB</i>	408-852-2849	Noncredit Program (Community Development)/ <i>Programa sin Créditos (Desarrollo en la Comunidad)</i>	408-852-2824
ASB Office/ <i>Oficina de ASB</i>	408-848-4777	Placement/Assessment Testing/ <i>Exámen de Colocación-Evaluación</i>	408-846-4992
Assessment Office/ <i>Oficina de Evaluaciones</i>	408-846-4992	Sign up/ <i>Registrarse</i>	408-846-4954
Athletics/Physical Education/ <i>Deportes, Educación Física</i>	408-848-4876	Online/Telecourses/ <i>Cursos por Internet/Televisados</i>	408 848-4885
Aviation/ <i>La Escuela del Aire</i>	408-852-2861	Outreach & Recruitment/Tours/ <i>Oficina de Inscripciones/Visitas al Campus</i>	408-846-4993
Bookstore/ <i>Librería</i>	408-848-4742	President's Office/ <i>Oficina del Presidente</i>	408-848-4711
Business Skills Center/ <i>Centro de Conocimientos Comerciales</i>	408-848-4786	Public Information Office/ <i>Oficina de Información Pública</i>	408-848-4724
CalWORKs/ <i>Programa de Experiencia de Trabajo en el área que se requiera</i>	408-848-4740	Puente Program/ <i>Programa "Puente"</i>	408-848-4807
CARE - Cooperative Agencies Resources for Education/ <i>Agencias Cooperativas para Recursos de Educación</i>	408-848-4790	R.O.P. - Regional Occupational Programs/ <i>Programas Regionales Laborales</i>	408-848-4816
Career/Transfer Resource Center/ <i>Centro de Recursos para Carreras y Transferencias</i>	408-848-4818	STAR-Summer Theatre Arts Repertory/ <i>Repertorio de Artes Teatrales de Verano</i>	408-612-2057
Carpenter Training Center Apprenticeship Program/ <i>Centro de Entrenamiento en Carpintería, Aprendizaje</i>	408-852-2815	Theatre Arts Box Office/ <i>Taquilla del Teatro</i>	408-846-4973
Cashier (Business Office)/ <i>Cajero (Oficina de Negocios)</i>	408-848-4714	Transfer (Career/Transfer Resource Center)/ <i>Trasferencias (Centro de Recursos para Transferencias y Carreras)</i>	408-848-4818
Cashier (Student Accounts)/ <i>Cajero (Cuentas de Estudiantes)</i>	408-852-2840	Transfer Institute/ <i>Instituto de Transferencias</i>	408-848-4723
Child Development Center/ <i>Centro de Desarrollo Infantil</i>	408-848-4815	TRIO Student Support Services/ <i>Servicios de Apoyo Estudiantil TRIO</i>	408-846-4981
CMAP - Community Media Access Partnership/ <i>Sociedad de Medios Informativos para Acceso a la Comunidad</i>	408-846-4983	TTY (for Deaf or Hard of Hearing)/ <i>TTY (para Discapacitados Auditivos)</i>	408-846-4924
Community/Contract Education/ <i>Educación en la Comunidad/Contrato</i>	408-852-2801	Tutoring Center/ <i>Centro de Tutoría</i>	408-848-4838
Computer Graphics & Design (CGD) Lab/ <i>Estudio CGD</i>	408-848-4868	Veterans' Services/ <i>Servicios a los Veteranos</i>	408-848-4734
Computer Place/ <i>Lugar de las Computadoras</i>	408-848-4729	Vice President's Office/ <i>Oficina del Vice Presidente:</i>	
Cooperative Work Experience/ <i>Cooperativa de Experiencias de Trabajo</i>	408-848-4813	Student Services/ <i>Servicios Estudiantiles</i>	408-848-4738
Cosmetology Appointment line/ <i>Cosmetología/Teléfono para Citas</i>	408-842-5055	Instructional Services/ <i>Servicios de Instrucción</i>	408-848-4761
Counseling Office/ <i>Oficina de Asesoría</i>	408-848-4723	Work Experience/ <i>Experiencia de Trabajo</i>	408-848-4813
Dean/ <i>Decano:</i>		Writing Center/ <i>Centro de Escritura</i>	408-848-4811
Career Technical Education/ <i>Carrera de Educación Técnica</i>	408-848-4719		
Liberal Arts & Sciences/ <i>Ciencias y Humanidades</i>	408-848-4701		
Physical Education & Athletics/ <i>Educacion Fisica y Deportes</i>	408-848-4876		
Digital Media (Studio DM) - CGD lab/ <i>Centro Digital de Medios informativos (Estudio DM) - Lab CGD</i>	408 848-4800, ext. 5604		
DRC - Disability Resource Center/ <i>Centro de Recursos para Discapacitados DRC</i>	408-848-4865		
Discrimination-Harassment Complaints/ <i>Oficina de Quejas por Discriminación y Acoso</i>	408-848-4731		

Schedule Development Team

Rosie Armstrong, Mimi Arvizu, Sherrean Carr, Jan Bernstein Chargin, Michele Cortes, Katie Day, Bonnie Donovan, Fran Lopez, Michelle Lopez, Fran Lozano, Terri Newman, Jesus Olivas, Rachel Perez, Dave Phillips, John Pruitt, Diane Stone, Cindy Starr, Candice Whitney
 Photos by: Jan Bernstein Chargin, Pablo Balancio, James Frazier, Norm Haughey, Kimberly Smith, Cindy Starr
 Printed by: Folger Graphics

MAIN CAMPUS, GILROY

5055 Santa Teresa Blvd.
 Gilroy, CA 95020
 408-848-4800 or
 831-637-1158 (from Hollister)

Building Guide

- APE Adapted Physical Education
- AR Art
- BOB Business Office Building
- BU Business
- CDC Child Development
- CE Community Education
- CHP Chapel
- COS Cosmetology
- GY Gym
- HOB Health Occupations Bldg.
- HR Human Resources
- HRC Human Resources Conference Center
- HU Humanities
- LI Library
- LS Life Science
- MA Mathematics
- MAY Mayock House
- MP Multipurpose Building
- MU Music Hall
- PB Portable Buildings
- PS Physical Science
- SC Student Center/Administration
- SF Security/Facilities
- SS Social Science
- TH Theater



Bicycle Racks



Spring Construction Zones

Key to Gavilan

Administration	SC
Admissions & Records	SC111
Art Gallery	LI
ASB	SC158
Assessment Center	MP100
Athletics Office	GY
Aviation	PB 11-I
Basic Skills Counselor	LI157
Bookstore	SC
Business Office	BOB
Cafeteria	SC
CalWORKs	LI101A
Career/Transfer Resource Ctr.	SC101
Cashier	BOB
Cashier (Student Accounts)	SC
Child Development Center	CDC
Children's Preschool	CDC
CMAP	LI135
Community Ed	CE
Computer Graphics & Design	LI126
Computer Place	LI168
Coop. Work Exp.	LI101A
Cosmetology	COS
Counseling Secretary	SC113
Disability Resource Center	LI117
Early College Academy	PB16-20
English	PB11-J
ESL	PB11-L
EOPS/Special Services	LI101A
Financial Aid Office	SC124
Lounges, North and South	SC154N/S
Math Lab	MA101
MESA	MA115
Music	MU
Noncredit Program	PB2
Nursing	HOB
Payroll	BOB
Physical Education	GY
Police Academy	MP
Public Information Office	PB2
Researcher	BU124
Security	SF
Staff Resource Center	PB11-N
STEM Counselor	LI158
Student Health Nurse	SC118
Student Senate Office	SC
TRIO Program	LI109
Tutoring Center Services	LI116
TV Studio	LI

Parking Lots

- A Student/Staff/Disabled Access/30 min. spaces
- B Student/Staff/Disabled Access/Visitor/30 min. spaces
- C Student/Staff/Disabled Access/15 min. spaces/30 min. spaces
- D Staff/Disabled Access
- E Student/Staff/Motorcycle
- F Staff/Disabled Access/Visitor/Motorcycle/30 min. spaces
- G Staff/Disabled Access
- H Student/Staff/Disabled Access/Motorcycle/30 min. spaces

DON'T GO TO THE WRONG CITY!
MHG = Morgan Hill
HOL = Hollister



Mesa Rd.

Santa Teresa Blvd.

Gavilan College
5055 Santa Teresa Blvd.
Gilroy, CA 95020

(408) 848-4800

www.gavilan.edu

Non-Profit
US Postage PAID
Permit # 195
Gilroy, CA 95020

SPRING EVENTS

Science Alive! - February 5
VDAY - February 12
Bach to Blues - March 5
Fiesta Mexico! - March 19
Graduation - May 27



gavilan.edu/gavtv

The Gavilan College Channel

ORIGINAL PROGRAMMING

Carol on Creativity
Good Morning Gavilan
Gavazine
Great Kitchens
Gavilan College Connections
Art is Essential
Lets Ask Alice

Live-streamed games & events:
gavilan.edu/sports



- register now -

**Gavilan College
Child Development
Center**

(408) 848- 4815

Monday - Friday

7:00am - 6:00pm

2 years - 5 years * Full-time and Part-time
Community members and Gavilan College Students
Breakfast, Lunch, Snacks, and Activities
Indoor and outdoor play areas and campus fun!

Study Spanish in Spain! Summer travel program – see page 99