

CRN Type Room Instructor Hrs. Units Days Begin-End

CRN Type Room Instructor Hrs. Units Days Begin-End

 **ONLINE CLASSES:** Start by going to <http://www.gavilan.edu/disted>

You must have an email account to take an online course. Unless you have made prior arrangements with the instructor, you MUST log on by 11:59 pm on the first day of the course. Late adds must login within 24 hours of adding this course. If you miss the deadline you may be dropped. For help, contact your instructor or email disted@gavilan.edu.

DM 140 Basic Digital Film/Video Production

Transferable: CSU, UC; GAV-GE:C1

An on-line self-paced course covering the basics of film/video production and post production (editing) using "easy to use" computer software such as Apple's iMovie. Beneficial for students who are producing a video/film project as a requirement for another college course, extra skills development, or for self interest. Completion of the associated class or personal project in DVD format using either personal video equipment or the equipment in the Digital Media Studio is required. May be repeated twice for credit. This course has the option of a letter grade or pass/no pass. This course is also listed as ART 140 and CSIS 140.

 40826 Online R Beede 1.0 See information above about online classes.

**Drama: See Mass Communications & Television, Theatre Arts
Early Childhood Education: See Child Development**

ECOLOGY

ECOL 1 Conservation of Natural Resources

Transferable: CSU, UC; CSU-GE:B2, B3, IGETC:5B; GAV-GE:B2, B3

This course examines the fundamentals of ecology (the study of the relationships between organisms and their environment) with special emphasis on human effects on the environment. Topics of discussion will include ecosystem dynamics, resources, pollution, population growth, and the clash between economic and political policy and the environment. ADVISORY: Eligible for English 250 and English 260.

40463	L/L	PS105	R Morales	3.3	4.0	F	1120-0225
	L/L	LS102	R Morales	3.3		S	0900-1205
This service learning course section involves community work. See page 19 for more information.							
40461	Lec	LS101	J Hubbard	3.2	4.0	TR	1250-0210
	Lab	LS102	J Hubbard	3.3		T	0230-0535
40462	Lec	LS101	J Hubbard	3.2	4.0	TR	1250-0210
	Lab	LS102	J Hubbard	3.3		R	0230-0535

ECONOMICS

ECON 1 Principles of Macroeconomics

Transferable: CSU, UC; CSU-GE:D2, IGETC:4B; GAV-GE:D2; CAN:ECON2

Introduction to the principles of macroeconomics, social organization of the economy; supply and demand; the determinants of national income and production, economic growth, the global economy and trade, employment, prices, savings and investment; the nature and effectiveness of monetary and fiscal policy. This course has the option of a letter grade or pass/no pass. ADVISORY: Eligible for English 1A and Mathematics 233.

40383	Lec	HOL2	D Carlisle	3.0	3.0	F	1120-0210
Above class meets at the Hollister Briggs site.							
40326	Lec	BU120	B Truongson	3.2	3.0	TR	1250-0210
40863	Lec	MHG 5	B Truongson	3.0	3.0	M	0600-0905
Above class meets at the Morgan Hill Community Center site.							
	40327	Online	D Carlisle	3.0	See information above about online classes.		

ECON 2 Principles of Microeconomics

Transferable: CSU, UC; CSU-GE:D2, IGETC:4B; GAV-GE:D2; CAN:ECON4

Introduction to microeconomic principles and theory; supply, demand; product and factor price determination, resource allocation, costs, revenues, and profits under different competitive situations; international trade; government regulation and taxation. Note: Economics 1 is not a prerequisite for Economics 2. This course has the option of a letter grade or pass/no pass. ADVISORY: Eligible for English 260, English 250 and Mathematics 233.

40384	Lec	MHG5	B Truongson	3.2	3.0	TR	0945-1105
Above class meets at Morgan Hill Community site.							
40385	Lec	PB13	A Shokou	3.3	3.0	T	0600-0905



Education: see Child Development, Liberal Arts, Liberal Arts with Elementary Education Emphasis

ENGLISH



ENGL 1A Composition

Transferable: CSU, UC; CSU-GE:A2, IGETC:1A; GAV-GE:A2; CAN:ENGL2, ENGL SEQ A

This is a writing course which emphasizes expository writing, argumentative writing, and critical reading of expository prose. It is meant to train students in clear thinking and reasoned support of ideas. Students will be given the opportunity to read models of good expository and argumentative prose and learn the techniques of good writing. These include choosing appropriate subjects, developing restricted, unified, and precise theses and presenting supporting evidence in a logical, lucid, and effective manner. To achieve this end, students write no fewer than six essays and read at least five works, two of which are book length. PREREQUISITE: English 250 and English 260 or English 250 and SSCI 270A or English 250 and SSCI 270B with a grade of 'C' or better or satisfactory score on the English placement examination.

	1	Your ENGL 1A class has a theme.						
	2	See list on page 53.						
2	40032	Lec	HU102	T Mack	3.2	3.0	MW	0810-0930
	40033	Lec	HU102	D Condon	3.2	3.0	TR	0810-0930
	40034	Lec	MHG12	M Bragger	3.2	3.0	MW	0810-0930
Above class meets at Morgan Hill Community site.								
	40035	Lec	HOL5	G Mora	3.3	3.0	F	0900-1205
Above class meets at the Hollister Briggs site.								
	40064	Lec	MHG3	M Bragger	3.3	3.0	F	0900-1205
Above class meets at Morgan Hill Community site.								
11	40038	Lec	HU103	J Roscher	3.2	3.0	TR	0945-1105
3	40036	Lec	HOL5	C Salvin	3.2	3.0	TR	1120-1240
Above class meets at the Hollister Briggs site.								
3	40039	Lec	HU102	C Salvin	3.2	3.0	MW	1120-1240
11	40042	Lec	PB14	J Roscher	3.2	3.0	TR	1250-0210
	40043	Lec	HU102	J Gatewood	3.2	3.0	MW	1250-0210
	40044	Lec	HU102	Staff	3.2	3.0	MW	0230-0350
5	40045	Lec	HU103	S Schessler	3.2	3.0	TR	0400-0520
6	40058	Lec	PB4	T Brett	3.3	3.0	R	0600-0905
	40061	Lec	HOL1	S Sloan	3.3	3.0	W	0600-0905
Above class meets at the Hollister Briggs site.								
	40062	Lec	HU102	Staff	3.3	3.0	M	0600-0905
2	40063	Lec	MHG3	T Mack	3.3	3.0	T	0600-0905
Above class meets at Morgan Hill Community site.								

ONLINE:

	1	40031	Online	D Luoma	3.0	See information above about online classes.	
		40037	Online	E Crook	3.0	See information above about online classes.	

PUENTE PROGRAM:

4	40041	Lec	HU103	S Sandler	3.2	3.0	TR	1120-1240
Students enrolled in this class will participate in the PUENTE Program and will need to complete 10 hours of mentoring. Required: Complete an application with the PUENTE counselor prior to registration. This class is part of a learning community. Students must also enroll in GUID 1, CRN 40170. See ad on page 55.								

Have you met the prerequisite? **It's required!**

CRN Type Room Instructor Hrs. Units Days Begin-End

ENGL 1B Composition and Literature

Transferable: CSU, UC; CSU-GE:C, IGETC:3B; GAV-GE:C2; CAN:ENGL4, ENGL SEQ A

English 1B continues the work begun in 1A, but now the emphasis shifts to writing expository prose in conjunction with reading and analyzing imaginative literature. Students are to write as fledgling critics and use the text as a basis for other forms of reflection. The reading requirement includes short stories, poetry, drama, and at least two novels. Course work will also include fundamentals of research writing. **PREREQUISITE:** English 1A with a grade of "C" or better.

40068	Lec	HU103	S Hirasuna	3.3	3.0	F	0900-1205
40067	Lec	HU102	G Richards	3.2	3.0	TR	0945-1105
40069	Lec	HU103	E Crook	3.2	3.0	MW	1120-1240
40072	Lec	MA102	S Knapp	3.2	3.0	MW	1250-0210
14 40071	Lec	HU103	S Schessler	3.2	3.0	TR	1250-0210
14 40073	Lec	HU103	S Schessler	3.2	3.0	TR	0230-0350
40066	Lec	MHG13	Staff	3.2	3.0	MW	0400-0520
Above class meets at Morgan Hill Community site.							
7 40074	Lec	PB4	T Brett	3.3	3.0	W	0600-0905

ONLINE:

40065	Online	J Hooper	3.0	See info on page 52 about online classes.			
40070	Online	K Warren	3.0	See info on page 52 about online classes.			

ENGL 1C Critical Reasoning and Writing

Transferable: CSU, UC; CSU-GE:A3, IGETC:1B; GAV-GE:C2

This course is designed to develop critical thinking, reading, and writing skills beyond the level achieved in English 1A. The emphasis is on critical analysis of arguments and the development of the ability to integrate the principles of critical thinking into essay writing. **PREREQUISITE:** English 1A with a grade of "C" or better.

40095	Lec	HU103	G Mora	3.2	3.0	MW	0810-0930
40097	Lec	MA102	Condon	3.2	3.0	TR	1120-1240
40098	Lec	HU103	M Oral	3.2	3.0	MW	0230-0350
40099	Lec	HU102	K Smith	3.2	3.0	TR	0400-0520
40096	Lec	HOL1	K Hull	3.2	3.0	MW	0400-0520
Above class meets at the Hollister Briggs site.							
8 40100	Lec	PB4	T Brett	3.3	3.0	M	0600-0905

ONLINE:

40094	Online	C Chaffin	3.0	See info on page 52 about online classes.			
-------	--------	-----------	-----	---	--	--	--

ENGL 2J Mythology

Transferable: CSU, UC; CSU-GE:C2, IGETC:3B; GAV-GE:C2

This course is a survey of myths from around the world, with an emphasis on literary analysis of the myths. The course covers the purposes and types of myths; the development of myths and mythological characters, the recurring elements of mythological structures, the influence of mythology on contemporary texts. **PREREQUISITE:** Eligible for English 1A.

40154	Lec	PB14	K Warren	3.2	3.0	TR	1120-1240
-------	-----	------	----------	-----	-----	----	-----------

ENGL 4B British Literature - 1798 to Present

Transferable: CSU, UC; CSU-GE:C2, IGETC:3B; GAV-GE:C2; CAN:ENGL10, ENGL SEQ B

This course is a study of the masters of British Literature from 1798 to present. In this course we will read and analyze the literature of Blake, Wordsworth, Coleridge, Byron, Shelley, Keats, Tennyson, Browning, Arnold, Clough, Hopkins, Rossetti, Bronte, Yeats, Joyce, Woolf, Lawrence, Eliot, and Forster. Note: this course need not be taken in sequence. **PREREQUISITE:** Eligible for English 1A.

40269	Lec	PB13	S Sandler	3.2	3.0	MW	1120-1240
-------	-----	------	-----------	-----	-----	----	-----------

ENGL 9A Introduction to Creative Writing

Transferable: CSU, UC; CSU-GE:C2; GAV-GE:C2; CAN:ENGL6

This course includes the writing, reading, and critical discussions of various forms of poetry and fiction. **PREREQUISITE:** Eligible for English 1A.

40270	Lec	PB4	K Smith	3.2	3.0	TR	1250-0210
-------	-----	-----	---------	-----	-----	----	-----------

Choose a **THEME** for your English class:

Find the number, by the course section number, that corresponds to a theme below.

- 1 Read classics of nature writing and visit the virtual woods with Thoreau.
- 2 Chicana(o) Style: Step into the world of the Mexican-American, the bi-racial, bi-cultural experience. We'll read literature that will have you laughing your socks off one moment and scratching your head the next. Learn about or relive the joys and pains of the wonderful and sometimes strange Mexican-American life!
- 3 Investigate environmental issues, particularly those connected to what we eat and where we live.
- 4 Punte: Develop writing skills through an emphasis on Chicano/Latino literature.
- 5 Consider how marginalized writers can make an impact on mainstream social thinking and develop the argumentation skills to make its voice heard.
- 6 Explore the exciting realm of science and discover who we are, how we got here, and learn about the scientists and explorers who got us here while learning to write with panache, flair, and accuracy.
- 7 Explore the great literature of the human condition, challenging you to respond to literary art, science fiction, music, tragedy, and the joy of life and living.
- 8 Learn to think courageously, to think intelligently, and to think for yourself through challenging the pseudoscientific, the paranormal, and the make-believe world of nutty beliefs and scams.
- 9 Service Learning: Explore the connections between language, identity, and community through our work with ESL (English as a Second Language) students.
- 10 Explore American consumerism and wild alternatives.
- 11 The American Dream: Revisit the land of freedom and equality.
- 12 First Year Experience: Learn to critically read, write, and think about contemporary issues; evaluate the credibility of sources ranging from academia to the media; and embrace the importance of understanding what is happening in the world around you.
- 13 First Year Experience: Explore the issues of peace and conflict through reading and writing.
- 14 American Outsiders: Explore American literature from the "outsider's" perspective, focusing on works from authors protesting the American mainstream or demanding to be let in.
- 15 Telling Our Stories: Explore how storytelling makes us stronger, and read authors such as Victor Villaseñor in *Burro Genius* whose lives can inspire us.

First Year Experience A Wise Choice

- higher GPA,
- increased involvement in school,
- more friends,
- more fun in school,
- ability to meet goals,
- stronger critical thinking, reading, and writing abilities,
- saving time and money

First Year Experience (FYE) is a program in place in many colleges across the country. This program was developed because research has shown that students who make connections with their teachers, classmates, and campus are more likely to succeed. So what is FYE? At Gavilan, this program links required English courses together and provides tutoring and counseling. How do students benefit? By working together with your classmates and instructors, you will develop a stronger network of support. Students who enroll in FYE often report

MARK YOUR CALENDARS - Thursday, January 27th from 9 am - 1 pm, Student Success Orientation. Meet your instructors! Find out where your classes are and how to get money for books! Get connected with programs on campus such as EOPS, TRIO, MESA and more. Free lunch provided. RSVP to Michelle Foguet-Mendoza at 408-848-4776 ASAP; spaces are limited.

What FYE has meant to me:

"First Year Experience has been very important to me. I was a shy person and had trouble asking for help. I was not as successful as I wanted to be. I discovered that getting help from people makes it easier to get things done without so much stress about it. Now I ask for help from my teacher, tutors, and counselors, and I visit the Writing Center often. My life has changed a lot. I'm so grateful Gavilan College has this program." *Veronica*

"I took this class last semester and learned a lot more than I did in high school. It's amazing and you will learn to like English. I hated English in high school and taking FYE has helped me in many ways, from writing a paper to being organized. You will write a lot in all of your classes and this program helps you be more successful. It does more than just refresh you." *Karissa*

"I have gained confidence in English at Gavilan. I will take with me the faster reading strategies on how to take notes or highlight the most important facts that summarize what I finished reading. Overall, the pride of reading will stick with me through the summer and I have never had much confidence in reading going into summer" *Alex*



Get a head start and get prepared BEFORE the semester begins!

Plan on attending our student success orientation.

Thursday, January 27th

9 am - 1 pm

Free lunch included!

RSVP to Michelle Foguet-Mendoza at 408-848-4776.

The following classes are part of a First Year Experience learning community. You must enroll in both courses.

ENGL 250 Practical Writing

40124	Lec	PB4	S White	3.2	3.0	MW	1250-0210
	Lab	LI171	S White	1.0		M	0230-0320

ENGL 260 Preparation for College Reading

40150	Lec	PB4	J Gatewood	3.2	3.0	MW	1120-1240
-------	-----	-----	------------	-----	-----	----	-----------

or

ENGL 250 Practical Writing

40125	Lec	PB4	S White	3.2	3.0	MW	1250-0210
	Lab	LI171	S White	1.0		W	0230-0320

ENGL 260 Preparation for College Reading

40151	Lec	PB4	J Gatewood	3.2	3.0	MW	1120-1240
-------	-----	-----	------------	-----	-----	----	-----------

ENGL 250 Practical Writing

40122	Lec	HU102	J Hooper	3.2	3.0	TR	1250-0210
	Lab	LI120	J Hooper	1.0		T	0230-0320

ENGL 260 Preparation for College Reading

40147	Lec	HU102	J Hooper	3.2	3.0	TR	1120-1240
-------	-----	-------	----------	-----	-----	----	-----------

ENGL 747 Film and Literacy *recommended*

40901	Lec	HU102	J Hooper	4.2		R	0600-0930
-------	-----	-------	----------	-----	--	---	-----------

Class meets these Thursdays, 02/17, 03/17 and 04/14.

or

ENGL 250 Practical Writing

40123	Lec	HU102	J Hooper	3.2	3.0	TR	1250-0210
	Lab	LI120	J Hooper	1.0		W	1120-1210

ENGL 260 Preparation for College Reading

40148	Lec	HU102	J Hooper	3.2	3.0	TR	1120-1240
-------	-----	-------	----------	-----	-----	----	-----------

ENGL 747 Film and Literacy *recommended*

40901	Lec	HU102	J Hooper	4.2		R	0600-0930
-------	-----	-------	----------	-----	--	---	-----------

Class meets these Thursdays, 02/17, 03/17 and 04/14.

ENGL 420 Reading Improvement

40251	Lec	PB14	K Warren	3.2	3.0	MW	1120-1240
	Lab	LI171	K Warren	1.0		M	1010-1100

ENGL 440 Basic Writing

40260	Lec	PB14	K Warren	3.2	3.0	MW	1250-0210
	Lab	LI171	K Warren	1.0		W	1010-1100

or

ENGL 420 Reading Improvement

40252	Lec	PB14	K Warren	3.2	3.0	MW	1120-1240
	Lab	LI171	K Warren	1.0		T	1120-1210

ENGL 440 Basic Writing

40261	Lec	PB14	K Warren	3.2	3.0	MW	1250-0210
	Lab	LI171	K Warren	1.0		T	1220-0110

CRN Type Room Instructor Hrs. Units Days Begin-End

ENGL 9B Advanced Creative Writing

Transferable: CSU, UC; CSU-GE:C2; GAV-GE:C2

This class is a continuation of English 9A, with the emphasis shifting to publication. The genre of non-fiction will be the primary focus, but the genres of fiction will also be taught at a more comprehensive level than in English 9A. The process of finding a market for one's work will be followed step by step. The class may compile and publish "Soaring", Gavilan's literary magazine, each spring semester. PREREQUISITE: English 9A with a grade of credit or C or better.

40271 Lec PB4 K Smith 3.2 3.0 TR 1250-0210

ENGL 9C Poetry Writing

Transferable: CSU, UC; CSU-GE:C2; GAV-GE:C2

This course includes the writing, reading, and critical discussions of various forms of poetry. PREREQUISITE: English 9A with a grade of credit or C or better.

40272 Lec PB4 K Smith 3.2 3.0 TR 1250-0210

ENGL 12B Tutoring Writers: Training/Theory & Practice

Transferable: CSU

Fundamentals of compositional theory, the writing process, peer-to-peer communication, interacting with faculty and educational institutions and effective responses to writing will be covered. In addition, students will gain an understanding of the basic history, methodology and practice of writing pedagogy while developing a writing community that aids in connecting them to their own writing practice. ADVISORY: Eligible for English 1A.

40028 Lec LI120 K Smith 1.0 1.0 M 0300-0400

ENGL 12C Tutoring Writers: Training/Theory & Practice

Transferable: CSU

Fundamentals of compositional theory, the writing process, peer-to-peer communication, interacting with faculty and educational institutions and effective responses to writing will be covered. In addition, students will gain an understanding of the basic history, methodology and practice of writing pedagogy while developing a writing community that aids in connecting them to their own writing practice. ADVISORY: Eligible for English 1A.

40029 Lec LI120 K Smith 1.0 1.0 M 0300-0400

ENGL 12D Tutoring Writers: Training, Theory & Practice

Transferable: CSU

Fundamentals of compositional theory, the writing process, peer-to-peer communication, interacting with faculty and educational institutions and effective responses to writing will be covered. In addition, students will gain an understanding of the basic history, methodology and practice of writing pedagogy while developing a writing community that aids in connecting them to their own writing practice. ADVISORY: Eligible for English 1A.

40030 Lec LI120 K Smith 1.0 1.0 M 0300-0400

ENGL 22 Field Work and Service

Transferable: CSU

Supervised field work within the college and with local agencies. Students serve in useful group activities in leadership roles prescribed for them by faculty or community agencies. A maximum of six units may be completed. This is a pass/no pass course. REQUIRED: Learning contracts must be filled out and signed by the student and the supervising instructor.

40101 Fld Ex K Warren 1.0

ENGL 23 Independent Study

Transferable: CSU

Designed to afford selected students specialized opportunities for exploring areas at the independent study level. The courses may involve extensive library work, research in the community, or special projects. May be repeated until six units of credit are accrued. This course has the option of a letter grade or pass/no pass. REQUIRED: The study outline prepared by the student and the instructor must be filed with the department and the dean.

40103 Ind LI120 K Smith 1.0

40102 Ind LI120 K Smith 2.0

40104 Ind PB11 K Warren 1.0

40105 Ind PB11 K Warren 2.0



This class can fulfill your IGETC humanities transfer requirement.

ENGL 4B

British Literature 1798 to Present

Instructor: Scott Sandler



ENGL 2J Mythology

Instructor: Karen Warren

This course offers an exploration of the major figures and themes of Greek, Aztec and African mythologies.

Transferable to UC and CSU. Satisfies the Humanities requirement under both the CSU and IGETC GE patterns.

Have you met the prerequisite?
It's required!



The Puente Project is a two-semester program that combines three components: writing, counseling and mentoring to support students to transfer to four-year universities and colleges. The Guidance 6 course focuses on self assessment and career development. The English 1A course focuses on Mexican American/Latino literature. The program also includes a student leadership conference, university visits and mentor/student socials. The program is open to all eligible students. For more information, call Celia Marquez, Puente Co-Coordinator at 408-848-4807.

Required: Complete a program application with the Puente Counselor prior to registration.

GUID 1 CRN 40170 Marquez C MW 1120A-1240P
Students will need to complete 10 hours of mentoring.

ENGL1A CRN 40041 Sandler S TuTh 1120A-1240P

CRN Type Room Instructor Hrs. Units Days Begin-End

ENGL 250 Practical Writing

Transferable: No

This course covers writing clear, correct, effective essays and learning preliminary research skills. PREREQUISITE: English 440 or ESL 563 with a grade of 'C' or better or satisfactory score on the English placement examination.

1 Your ENGL 250
2 class has a theme.
3 See list on page 53.

9	40106	Lec	PB4	S Sandler	3.2	3.0	MW	0810-0930
		Lab	LI120	S Sandler	1.0		M	0945-1035
This service learning course section involves community work. See page 19 for more information.								
9	40107	Lec	PB4	S Sandler	3.2	3.0	MW	0810-0930
		Lab	LI120	S Sandler	1.0		W	0945-1035
This service learning course section involves community work. See page 19 for more information.								
	40109	Lec	PB4	J McMillen	3.2	3.0	TR	0810-0930
		Lab	LI120	J McMillen	1.0		F	0810-0900
	40110	Lec	PB4	J McMillen	3.2	3.0	TR	0810-0930
		Lab	LI120	J McMillen	1.0		F	0910-1000
10	40113	Lec	HU102	C Salvin	3.2	3.0	MW	0945-1105
		Lab	LI120	C Salvin	1.0		M	0845-0935
10	40114	Lec	HU102	C Salvin	3.2	3.0	MW	0945-1105
		Lab	LI120	C Salvin	1.0		W	0845-0935
10	40116	Lec	HOL5	C Salvin	3.2	3.0	TR	0945-1105
		Lab	HOL3	C Salvin	1.0		T	0845-0935
Above class meets at the Hollister Briggs site.								
10	40117	Lec	HOL5	C Salvin	3.2	3.0	TR	0945-1105
		Lab	HOL3	C Salvin	1.0		R	0845-0935
Above class meets at the Hollister Briggs site.								
	40118	Lec	PB4	J McMillen	3.2	3.0	TR	0945-1105
		Lab	LI120	J McMillen	1.0		F	1010-1100
	40119	Lec	PB4	J McMillen	3.2	3.0	TR	0945-1105
		Lab	LI120	J McMillen	1.0		F	1110-1200
	40134	Lec	MHG10	S Frazier	3.2	3.0	MW	0945-1105
		Lab	MHG10	S Frazier	1.0		M	0845-0935
Above class meets at Morgan Hill Community site.								
	40135	Lec	MHG10	S Frazier	3.2	3.0	MW	0945-1105
		Lab	MHG10	S Frazier	1.0		W	0845-0935
Above class meets at Morgan Hill Community site.								
	40120	Lec	MA102	M Oral	3.2	3.0	MW	1120-1240
		Lab	LI120	M Oral	1.0		M	1250-0140
	40121	Lec	MA102	M Oral	3.2	3.0	MW	1120-1240
		Lab	LI120	M Oral	1.0		W	1250-0140
	40126	Lec	HU102	O Osikomaiya	3.2	3.0	TR	0230-0350
		Lab	LI171	O Osikomaiya	1.0		T	0400-0450
	40127	Lec	HU102	O Osikomaiya	3.2	3.0	TR	0230-0350
		Lab	LI171	O Osikomaiya	1.0		R	0400-0450
	40128	Lec	HU102	Staff	3.2	3.0	MW	0400-0520
		Lab	LI120	Staff	1.0		M	0530-0620
	40129	Lec	HU102	Staff	3.2	3.0	MW	0400-0520
		Lab	LI120	Staff	1.0		W	0530-0620
	40130	Lec	PB14	K Diehl	3.2	3.0	TR	0630-0750
		Lab	LI120	K Diehl	1.0		T	0530-0620
	40131	Lec	PB14	K Diehl	3.2	3.0	TR	0630-0750
		Lab	LI120	K Diehl	1.0		R	0530-0620

↳ continued

Don't forget

A counselor's signature is required if you take 18 or more units (spring/fall) or 6 or more units (summer).

You do not need a counselor's signature to register for a class with a prerequisite that was successfully completed at Gavilan.

CRN Type Room Instructor Hrs. Units Days Begin-End

ENGL 250 Continued

40132	Lec	HOL5	V Parker	3.2	3.0	MW	0700-0820
	Lab	HOL5	V Parker	1.0		M	0830-0920
Above class meets at the Hollister Briggs site.							
40133	Lec	HOL5	V Parker	3.2	3.0	MW	0700-0820
	Lab	HOL5	V Parker	1.0		W	0830-0920
Above class meets at the Hollister Briggs site.							

FIRST YEAR EXPERIENCE CLASSES ENGL 250 CLASSES (See ad on page 54):

12	40124	Lec	PB4	S White	3.2	3.0	MW	1250-0210
		Lab	LI171	S White	1.0		M	0230-0320
This class is part of a Learning Community. If you enroll you must also enroll in ENGL 260, CRN 40150.								
12	40125	Lec	PB4	S White	3.2	3.0	MW	1250-0210
		Lab	LI171	S White	1.0		W	0230-0320
This class is part of a Learning Community. If you enroll you must also enroll in ENGL 260, CRN 40151.								
13	40122	Lec	HU102	J Hooper	3.2	3.0	TR	1250-0210
		Lab	LI120	J Hooper	1.0		T	0230-0320
This class is part of a Learning Community. If you enroll you must also enroll in ENGL 260, CRN 40147.								
13	40123	Lec	HU102	J Hooper	3.2	3.0	TR	1250-0210
		Lab	LI120	J Hooper	1.0		W	1120-1210
This class is part of a Learning Community. If you enroll you must also enroll in ENGL 260, CRN 40148.								

ENGL 260 Preparation for College Reading

Transferable: No; GAV-GE:A3

This is a course presenting strategies in the technique and practice of college level critical reading and thinking skills.

PREREQUISITE: Completion of English 420 or ESL 562 with a grade of 'C' or better or Assessment recommendation.

1 Your ENGL 260
2 class has a theme.
3 See list on page 53.

40145	Lec	HU103	K Hull	3.2	3.0	TR	0810-0930
40149	Lec	HU102	I Tracey	3.3	3.0	F	0910-1215
40146	Lec	PB4	K Hull	3.2	3.0	MW	0945-1105
40152	Lec	HU103	J Hooper	3.2	3.0	MW	1250-0210
Recommended: Attend a free noncredit class: ENGL 747, Film and Literacy: Meets Thursdays: 3/10-3/24.							
40153	Lec	HOL5	V Parker	3.2	3.0	MW	0530-0650
Above class meets at the Hollister Briggs site.							

FIRST YEAR EXPERIENCE CLASSES ENGL 260 CLASSES (See ad on page 54):

12	40150	Lec	PB4	J Gatewood	3.2	3.0	MW	1120-1240
This class is part of a Learning Community. If you enroll you must also enroll in ENGL 250, CRN 40124.								
12	40151	Lec	PB4	J Gatewood	3.2	3.0	MW	1120-1240
This class is part of a Learning Community. If you enroll you must also enroll in ENGL 250, CRN 40125.								
13	40147	Lec	HU102	J Hooper	3.2	3.0	TR	1120-1240
This class is part of a Learning Community. If you enroll you must also enroll in ENGL 250, CRN 40122.								
13	40148	Lec	HU102	J Hooper	3.2	3.0	TR	1120-1240
This class is part of a Learning Community. If you enroll you must also enroll in ENGL 250, CRN 40123.								

ENGL 420 Reading Improvement

Transferable: No

This is a practical, "how to" course teaching various methods of learning and reading college material. Using group and individual instruction in vocabulary, comprehension, and study skills, the students will increase their ability to survive academically, to profit, grow and succeed in all college courses, and to enjoy reading and learning. Units earned in this course do not count toward the associate degree and/or certain certificate requirements. This course has the option of a letter grade or pass/no pass. PREREQUISITE: Satisfactory score on the English placement examination.

40175	Lec	HOL1	K Scimeca	3.2	3.0	MW	0945-1105
	Lab	HOL1	K Scimeca	1.0		F	0910-1000
Above class meets at the Hollister Briggs site.							
40181	Lec	HOL1	K Scimeca	3.2	3.0	MW	0945-1105
	Lab	HOL1	K Scimeca	1.0		F	1010-1100
Above class meets at the Hollister Briggs site.							

↳ continued

CRN	Type	Room	Instructor	Hrs.	Units	Days	Begin-End
ENGL 420 Continued							
40249	Lec	PB14	S Hirasuna	3.2	3.0	TR	0945-1105
	Lab	LI120	S Hirasuna	1.0		R	1115-1205
40250	Lec	PB14	S Hirasuna	3.2	3.0	TR	0945-1105
	Lab	LI120	S Hirasuna	1.0		T	1115-1205
40253	Lec	HU103	D Luoma	3.2	3.0	MW	0500-0620
	Lab	HU103	D Luoma	1.0		M	0630-0720
40254	Lec	HU103	D Luoma	3.2	3.0	MW	0500-0620
	Lab	HU103	D Luoma	1.0		W	0630-0720

FIRST YEAR EXPERIENCE CLASSES ENGL 420 CLASSES (See ad on page 54):

40251	Lec	PB14	K Warren	3.2	3.0	MW	1120-1240
	Lab	LI171	K Warren	1.0		M	1010-1100
This class is part of a Learning Community. If you enroll you must also enroll in ENGL 440, CRN 40260.							
40252	Lec	PB14	K Warren	3.2	3.0	MW	1120-1240
	Lab	LI171	K Warren	1.0		T	1120-1210
This class is part of a Learning Community. If you enroll you must also enroll in ENGL 440, CRN 40261.							

ENGL 439 Basic Grammar and Reading

Transferable: No

This is a remediation course introducing basic reading and writing strategies, as well as study skills. Group and individual instruction will be used to build vocabulary, increase reading comprehension, develop study skills, and apply basic grammar to writing. Units earned in this course do not count toward the associate degree and/or certain certificate requirements. This is a pass/no pass course. ADVISORY: Assessment recommendation.

40255	L/L	PB14	S White	3.2	4.0	MW	0945-1105
	L/L	LI171	S White	3.3		F	0900-1205

ENGL 440 Basic Writing

Transferable: No

This is an intensive study and application of basic grammar, sentence, and essay writing skills within the context of composing short essays. Units earned in this course do not count toward the associate degree and/or certain certificate requirements. PREREQUISITE: Satisfactory score on the English placement examination.

40256	Lec	HU103	E Crook	3.2	3.0	MW	0945-1105
	Lab	LI120	E Crook	1.0		T	1010-1100
40257	Lec	HU103	E Crook	3.2	3.0	MW	0945-1105
	Lab	LI120	E Crook	1.0		R	1010-1100
40258	Lec	HOL1	K Scimeca	3.2	3.0	MW	1120-1240
	Lab	HOL1	K Scimeca	1.0		F	1110-1200
Above class meets at the Hollister Briggs site.							
40259	Lec	HOL1	K Scimeca	3.2	3.0	MW	1120-1240
	Lab	HOL1	K Scimeca	1.0		F	1210-0100
Above class meets at the Hollister Briggs site.							
40262	Lec	PB4	E Crook	3.2	3.0	TR	1120-1240
	Lab	LI120	E Crook	1.0		T	1250-0140
40263	Lec	PB4	E Crook	3.2	3.0	TR	1120-1240
	Lab	LI120	E Crook	1.0		R	1250-0140
40264	Lec	HU103	J Collins	3.2	3.0	TR	0600-0720
	Lab	LI120	J Collins	1.0		T	0730-0820
40265	Lec	HU103	J Collins	3.2	3.0	TR	0600-0720
	Lab	LI120	J Collins	1.0		R	0730-0820

FIRST YEAR EXPERIENCE CLASSES ENGL 440 CLASSES (See ad on page 54):

40260	Lec	PB14	K Warren	3.2	3.0	MW	1250-0210
	Lab	LI171	K Warren	1.0		W	1010-1100
This class is part of a Learning Community. If you enroll you must also enroll in ENGL 420, CRN 40251.							
40261	Lec	PB14	K Warren	3.2	3.0	MW	1250-0210
	Lab	LI171	K Warren	1.0		T	1220-0110
This class is part of a Learning Community. If you enroll you must also enroll in ENGL 420, CRN 40252.							

The Final Word!

Look for the Final Exams schedule on page 83.

ENGLISH COMPOSITION AND READING COURSE SEQUENCE

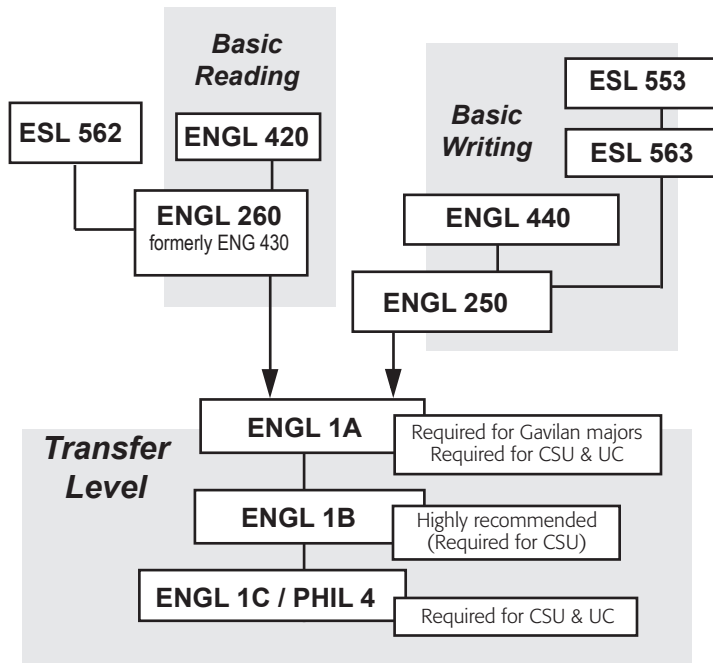

IT'S TIME TO PLAY!

English 9A, B, C

Poetry, Fiction & Drama



Research shows focussed play is good for mind, body and soul, making you more relaxed, and more productive. Come discover what you didn't know you wanted to say!

ENGL 749

WRITER'S WORKSHOP

Instructor: Kimberly Smith

Tuesday, 8:30 - 9:30 am
Wednesday, 3:00-6:00 pm
Thursday, 8:30 - 9:30 am

Meets in the Writing Center on the main campus in Gilroy.

See listing in the Noncredit section on page 92.



We help learners of all ages!

- Free tutoring for kids, teens and parents.
- Fun writing games and prompts.
- A relaxed and friendly atmosphere.

CRN	Type	Room	Instructor	Hrs.	Units	Days	Begin-End
-----	------	------	------------	------	-------	------	-----------

ENGLISH AS A SECOND LANGUAGE

All new ESL students must go through the ESL assessment process. See page 100.

Todos los nuevos estudiantes de ESL deben tomar el examen de nivelación de ESL. Consulte la página 100.

ESL 510A Basic ESL I

Transferable: No

This is an intensive, integrated-skill course for students with little English. Through listening, speaking, reading and writing activities, students learn to use the structures of English with increasing accuracy, while gaining basic life skills. ADVISORY: ESL Assessment Recommendation.

40001	Lec ARR	CE500	M Sanidad TBA	9.0 2.0	9.0	MTWRF	0950-1120
-------	------------	-------	------------------	------------	-----	-------	-----------

ESL 510B Basic ESL II

Transferable: No

This course is a continuation of ESL 510A. This is an intensive, integrated-skill program for students who function in a limited way in English. Through listening, speaking, reading and writing activities, students continue learning to use the structures of English with increasing accuracy, while gaining further basic life skills. ADVISORY: ESL 510A or ESL assessment recommendation.

40007	Lec ARR	CE500	K Campbell TBA	9.0 2.0	9.0	MTWRF	1130-0100
-------	------------	-------	-------------------	------------	-----	-------	-----------

ESL 521 Beginning ESL Listening/Speaking

Transferable: No

This course develops basic listening and speaking skills, moving from a functional survival context to academic readiness. Activities are directed at providing practice through listening exercises, role-play, pair work, small and large group discussion, interviews, and oral presentations. ADVISORY: ESL 510B or ESL Assessment Test Recommendation. Recommended concurrent enrollment in ESL 522 and 523.

40008	Lec ARR	HU101	K Baameur TBA	4.2 1.0	4.0	MWF	1105-1215
-------	------------	-------	------------------	------------	-----	-----	-----------

ESL 522 Beginning ESL Reading/Vocabulary

Transferable: No

This course begins the development of reading skills and vocabulary through the application of different reading strategies to a variety of selections on topics of interest to academically-bound students. ADVISORY: ESL 510B or 510C or Assessment recommendation. Recommended concurrent enrollment in ESL 521 and 523.

40009	Lec ARR	LI100	J Polizzotto TBA	3.2 2.0	3.0	TR	0940-1100
-------	------------	-------	---------------------	------------	-----	----	-----------

ESL 523 Beginning ESL Grammar/Writing

Transferable: No

This is a beginning grammar/writing course for students with very basic grammar. The focus is on basic grammatical structures, punctuation and sentence skills. ADVISORY: ESL 510B or ESL Assessment Test recommendation. Recommended concurrent enrollment in ESL 521 and ESL 522.

40010	Lec ARR	HU104	L Quijano TBA	5.2 1.0	5.0	MTWR	0820-0925
-------	------------	-------	------------------	------------	-----	------	-----------

ESL 528 Integrated Speaking/Listening I

Transferable: No

This is the first in a series of integrated skills courses designed to develop the listening, speaking and pronunciation skills of beginning ESL students. Activities, which include listening exercises, role-play, pair work, small and large group discussions, interviews, oral presentations and pronunciation drills (focusing on English sounds and rhythm), are presented in the context of relevant, contemporary and intellectually challenging themes. This course is designed especially for students with academic objectives but is highly appropriate for students with personal language goals, as well. PREREQUISITE: ESL 510B or ESL 503 or ESL Assessment recommendation.

40011	Lec	HU101	A Shelley	6.0	6.0	TR	0630-0930
-------	-----	-------	-----------	-----	-----	----	-----------

CRN	Type	Room	Instructor	Hrs.	Units	Days	Begin-End
-----	------	------	------------	------	-------	------	-----------

ESL 531 Intermediate ESL Listening/Speaking I

Transferable: No

In this course, listening and speaking skills are developed through extended listening exercises, open-ended dialogues, pair and group discussions, oral interviews, and oral reports. PREREQUISITE: ESL 521 or ESL 528 with a grade of 'C' or better or ESL Assessment Recommendation. Recommended concurrent enrollment in ESL 532 and 533.

40012	Lec ARR	HU104	N Cisneros TBA	4.2 1.0	4.0	MWF	0945-1055
-------	------------	-------	-------------------	------------	-----	-----	-----------

ESL 532 Intermediate ESL Reading/Vocabulary I

Transferable: No

This course continues the development of reading skills and vocabulary through the application of different reading strategies to a variety of selections on topics of interest to academically-bound students. PREREQUISITE: ESL 522 with a grade of 'C' or better or ESL assessment recommendation. Recommended concurrent enrollment in ESL 531 and 533.

40013	Lec ARR	HU104	M Bottega TBA	3.2 2.0	3.0	TR	0940-1100
-------	------------	-------	------------------	------------	-----	----	-----------

ESL 533 Intermediate ESL Grammar/Writing I

Transferable: No

This course involves the practice and refinement of sentence and paragraph skills, structure and punctuation. Students will learn basic use of the computer as a writing tool. PREREQUISITE: ESL 523 with a grade of C or better or ESL Assessment Test recommendation. ADVISORY: Recommended concurrent enrollment in ESL 531 and ESL 532.

40015	Lec ARR	LI100	B Lawn TBA	5.2 1.0	5.0	MTWR	1225-0130
-------	------------	-------	---------------	------------	-----	------	-----------

ESL 538 Integrated Listening/Speaking II

Transferable: No

This is the second in a series of integrated skills courses designed to develop the listening, speaking and pronunciation skills of low intermediate ESL students. Activities, which include listening exercises, role play, pair-work, small and large group discussions, interviews, oral presentations, and pronunciation (focusing on English sounds, rhythm and intonation), are presented in the context of relevant, contemporary and intellectually challenging themes. This course is designed especially for students with academic objectives but is highly appropriate for students with personal language goals as well. PREREQUISITE: ESL 528 or ESL 521 or ESL assessment recommendation.

40016	Lec	HU104	M Bottega	6.0	6.0	TR	0630-0930
-------	-----	-------	-----------	-----	-----	----	-----------

ESL 541 Intermediate ESL Listening/Speaking II

Transferable: No

This course expands listening and speaking skills through extended listening exercises, open-ended dialogues, pair and group discussions, oral interviews, and oral reports. Students broaden vocabulary while listening to and speaking in both formal and informal, conversational and academic situations. PREREQUISITE: ESL 531 or ESL 538 with a grade of 'C' or better or ESL assessment recommendation. Recommended concurrent enrollment in ESL 542 and 543.

40017	Lec ARR	HU104	N Cisneros TBA	4.2 1.0	4.0	MWF	1225-0135
-------	------------	-------	-------------------	------------	-----	-----	-----------

ESL 542 Intermediate ESL Reading/Vocabulary II

Transferable: No

This course begins the expansion of reading skills and vocabulary development through the application of different reading strategies to a variety of selections on topics of interest to academically-bound students including selections from literature. PREREQUISITE: ESL 532 with a grade of 'C' or better or ESL Assessment Recommendation. Recommended concurrent enrollment in ESL 541 and 543.

40018	Lec ARR	HU101	L Carrillo TBA	3.2 2.0	3.0	TR	0810-0930
-------	------------	-------	-------------------	------------	-----	----	-----------

ESL 543 Intermediate ESL Grammar/Writing II

Transferable: No

This course involves the expansion of sentence and paragraph skills, structure, and punctuation. Students will learn basic use of the computer as a writing tool. PREREQUISITE: ESL 533 with a grade of C or better or ESL assessment recommendation. ADVISORY: Recommended concurrent enrollment in ESL 541 and ESL 542.

40019	Lec ARR	HU101	K Campbell TBA	5.2 1.0	5.0	TWRF	0945-1050
-------	------------	-------	-------------------	------------	-----	------	-----------

CRN Type Room Instructor Hrs. Units Days Begin-End

ESL 546 Introduction to Computers for ESL Students

Transferable: No

Introduction to basic computer hardware functions and terminology; overview of Windows operating environment and word processing for ESL students. ADVISORY: CSIS 122. Eligible for Gavilan College ESL Program Intermediate.

40020 Lec BU119 Staff 1.0 1.0 W 1115-1205

ESL 548 Integrated Listening/Speaking III

Transferable: No

This is the third in a series of integrated skills courses designed to develop listening, speaking and pronunciation skills of high intermediate ESL students. Activities, which include listening exercises, role-play, pair work, small and large group discussions, interviews, oral presentations, and pronunciation drills (focusing on English sounds, rhythm and intonation), are presented in the context of relevant, contemporary, and intellectually challenging themes. This course is designed especially for students with academic objectives but is highly appropriate for students with personal language goals, as well. PREREQUISITE: ESL 538 or ESL 531 or ESL assessment recommendation.

40027 Lec LI100 L Nguyen 6.0 6.0 TR 0630-0930

ESL 552 Advanced ESL Reading/Vocabulary I

Transferable: No

This course focuses on academic and critical thinking skills needed to increase reading comprehension and efficiency. Emphasis is on analyzing, making inferences, taking notes, supporting opinions, summarizing and expanding vocabulary. Readings are from academic texts and literature. PREREQUISITE: ESL 542 with a grade of 'C' or better or ESL assessment recommendation. Recommended concurrent enrollment in ESL 553 and 554.

40021 Lec LI100 B Lawn 4.2 4.0 MWF 0945-1055

ESL 553 Advanced ESL Composition I

Transferable: No

This course is a composition course for ESL students that develops college composition skills through a review of the parts and elements of the English paragraph and an introduction to the essay form. The course focuses on the development of a paragraph and expands to the writing of multiple paragraphs in an essay. Basic rhetorical patterns and methods of organization are covered using the multiple-draft approach to writing. PREREQUISITE: ESL 543 with a grade of C or better or ESL Assessment Test recommendation. ADVISORY: Recommended concurrent enrollment in ESL 552 and ESL 554.

40022 Lec LI100 J Polizzotto 5.2 5.0 MTWR 0810-0915
ARR TBA 1.0

ESL 554 Advanced ESL Grammar I

Transferable: No

This course is designed to help students improve their grammar usage so that they will be able to expand their use of grammar structures in oral and written communication. Students begin the study of more sophisticated grammar structures such as past and future perfect, passive voice, and modal auxiliaries for past time, and they review perfect and modals for present and future time. Students will enhance their understanding of grammar by comparing and contrasting new and previously encountered structures and better appreciate the subtleties of English grammar. PREREQUISITE: ESL 543 with a grade of 'C' or better or ESL Assessment Test Recommendation. ADVISORY: Recommended concurrent enrollment in ESL 552 and ESL 553.

40023 Lec HU104 N Cisneros 5.2 5.0 MTRF 1110-1215
ARR TBA 1.0

ESL 562 Advanced ESL Reading/Vocabulary II

Transferable: No

This course prepares ESL students for mainstream college classes by reviewing a variety of reading skills, strategies, and topics from different academic disciplines. Students expand their academic vocabulary and read short stories or a novel for literary appreciation. PREREQUISITE: ESL 552 with a grade of 'C' or better or ESL assessment recommendation. Recommended concurrent enrollment in ESL 561 and/or ESL 564 and ESL 563.

40024 Lec HU101 K Baameur 4.2 4.0 MWF 0810-0920

Check Out Early & Late Start Classes! Page 90.

Register anytime before the first day of class.
Check the dates printed under the class CRN number.

OVERVIEW of ESL COURSES

NON CREDIT

LIFE SKILLS

VOCATIONAL

ESL 777	ESL 778	VESL	ESL 704A/B
ESL 779	ESL 780	To move from noncredit to credit ESL classes students must take an ESL assessment.	
ESL 781	ESL 782		

CREDIT - ACADEMIC TRACK

¿Es el inglés su Segundo Idioma?
Consulte la página 100 para información en Español sobre el examen de evaluación de ESL.

	Basic	510A	510B	DAYTIME CLASSES	Evening Classes
Beginning	521 L/S	522R	523GW	527RW	528L/S
Intermediate I	531 L/S	532R	533GW	537RW	538L/S
Intermediate II	541 L/S	542R	543GW	547RW	548L/S
Advanced I		552R	553W	554G	
Advanced II	561 L/S	562R	563W	564G	

SUPPLEMENTARY ESL COURSES:

- ESL 546 Intro Computers/ESL
- ESL 556 Intro Competency/ESL
- ESL 581 Pronunciation I
- ESL 582 Pronunciation II
- ESL 584 Culture through Film
- ESL 585 Editing for ESL Writers

ENGL 260 ENGL 250

ACADEMIC PROGRAMS or VOCATIONAL PROGRAMS

CRN Type Room Instructor Hrs. Units Days Begin-End

ESL 563 Advanced ESL Composition II

Transferable: No

This course, which is designed for ESL students, refines and further expands college composition skills through the writing of essays using the multiple-draft approach to writing. The course focuses on the structuring and development of an essay with the use of personal examples. Students write in response to a variety of prompts using different rhetorical patterns such as classification, cause/effect, and comparison/contrast. PREREQUISITE: ESL 553 with a grade of "C" or better or ESL Assessment Test recommendation. ADVISORY: Recommended concurrent enrollment in ESL 562 and ESL 564.

40025 Lec MA102 L Quijano 5.2 5.0 MTWR 0945-1050
ARR TBA 1.0

ESL 564 Advanced ESL Grammar II

Transferable: No

This course is designed to expand grammar usage to include adjective, noun, and adverb clauses in oral and written communication. Students learn the meaning and use of clause connectors and are introduced to conditionals, both real and unreal. These grammar structures constitute some of the most complex structures in English and expose students to a rich variety of structures that can effectively enhance their oral and written expression. PREREQUISITE: ESL 554 with a grade of 'C' or better or ESL Assessment Recommendation. ADVISORY: Recommended concurrent enrollment in ESL 562 and ESL 563.

40026 Lec LI100 B Lawn 5.2 5.0 TWRF 1110-1215
ARR TBA 1.0

CRN	Type	Room	Instructor	Hrs.	Units	Days	Begin-End
-----	------	------	------------	------	-------	------	-----------

ESL 581 ESL Pronunciation I

Transferable: No

This is a high-beginning/low-intermediate ESL Pronunciation Course. Students will participate in a variety of communicative activities designed to improve their pronunciation. This course focuses on clear pronunciation of vowels, consonants, diphthongs and clusters, accurate word stress and rhythm, and the connection between spelling and pronunciation. It also introduces the concept of sentence intonation. This is a pass/no pass course. ADVISORY: ESL 510B or ESL Assessment Test Recommendation.

40486	L/L	HOL1	N Cisneros	2.0	2.0	TR	0845-0945
-------	-----	------	------------	-----	-----	----	-----------

Above class meets at the Hollister Briggs site.

Film: see ENGL 2C, HUM 3, 4, 10
Foreign Languages: See French (FRNH),
Japanese (JPN) and Spanish (SPAN)

FRENCH**FRNH 1B Elementary French**

Transferable: CSU, UC; CSU-GE:C2, IGETC:6A; GAV-GE:C2

Continuation of French 1A with further development of the four skills of understanding, speaking, reading, and writing. Continued emphasis on culture. PREREQUISITE: French 1A, or equivalent.

40563	Lec	PB13	M Sanidad	5.2	5.0	MTWR	0810-0915
	ARR		M Sanidad	2.8			

FRNH 23 Independent Study

Transferable: CSU

Designed to afford selected students specialized opportunities for exploring areas at the independent study level. The courses may involve extensive library work, research in the community, or special projects. May be repeated until six units of credit are accrued. This course has the option of a letter grade or pass/no pass. REQUIRED: The study outline prepared by the student and the instructor must be filed with the department and the dean.

40564	Ind	PB11	M Sanidad	1.0			
-------	-----	------	-----------	-----	--	--	--

GEOGRAPHY**GEOG 1 Physical Geography**

Transferable: CSU, UC; CSU-GE:B1, B3, IGETC:5A; GAV-GE:B1, B3; CAN:GEOG6

An introductory study of the basic physical elements of geography including climate, land forms, soils, water, and natural vegetation. The laboratory will include the tools and methods of geographers. ADVISORY: Eligible for English 250 and English 260.

40284	L/L	HOL2	D Willahan	5.4	3.0	MW	0945-1210
-------	-----	------	------------	-----	-----	----	-----------

Above class meets at the Hollister Briggs site.

GEOLOGY**GEOL 1 Introduction to Geology**

Transferable: CSU, UC; CSU-GE:B1, B3, IGETC:5A; GAV-GE:B1, B3; CAN:GEOL2

A study of the earth and the physical properties which modify the earth; minerals, rocks, geologic structures and processes. ADVISORY: Eligible for English 250 and English 260.

40464	L/L	PB7	D Willahan	6.6	4.0	MW	1250-0355
-------	-----	-----	------------	-----	-----	----	-----------

Government: see Political Science
Graphic Arts: see Art, CGD, CSIS, Digital Media

CRN	Type	Room	Instructor	Hrs.	Units	Days	Begin-End
-----	------	------	------------	------	-------	------	-----------

GUIDANCE**GUID 1 Self-Assessment and Career Development**

Transferable: CSU; CSU-GE:E2; GAV-GE:E2

This course is designed to assist the student in learning more about personal values, personality, interests, exploration of career choice, and occupational opportunities through the use of various personal assessment instruments. The delivery options for this course also include online and self-paced formats. This course is also listed as PSYC 5. ADVISORY: Eligible for English 250 and English 260. \$12 fee will be charged for career assessment materials.

40166	Lec	HU105	J Godley	3.2	3.0	TR	1250-0210
-------	-----	-------	----------	-----	-----	----	-----------

ONLINE:

 40168 Online L Tenney 3.0 Start by going to <http://www.gavilan.edu/disted>. You must have an email account to take this course. Unless you have made prior arrangements with the instructor, you MUST log on by 11:59 pm on the first day of the course. Late adds must login within 24 hours of adding this course. If you miss the deadline you may be dropped. For help, contact your instructor or email disted@gavilan.edu.

PUENTE PROGRAM:

40170	Lec	LS106	C Marquez	3.2	3.0	MW	1120-1240
-------	-----	-------	-----------	-----	-----	----	-----------

Students enrolled in this class will participate in the PUENTE Program and will need to complete 10 hours of mentoring. Required: Complete an application with the PUENTE counselor prior to registration. This class is part of a learning community. Students must also enroll in ENGL 1A, CRN 40041. See ad on page 61.

GUID 22 Field Work and Service

Transferable: CSU

Supervised field work within the college and with local agencies. Students serve in useful group activities in leadership roles prescribed for them by faculty or community agencies. A maximum of six units may be completed. This is a pass/no pass course. REQUIRED: Learning contracts must be filled out and signed by the student and the supervising instructor.

40422	Fid Ex	LI117	S STAFF	1.0			
-------	--------	-------	---------	-----	--	--	--

Contact the Disability Resource Center (DRC) office.

GUID 191A Workplace Skills

Transferable: CSU

Workplace Skills teaches skills vital to workplace success. The topic for 191A is Interpersonal Communication. Need not be taken in sequence. This is a pass/no pass course.

40867	Lec	MHG8	F Mendez	3.9	1.0	F	0900-1235
-------	-----	------	----------	-----	-----	---	-----------

04/29/11 - 05/27/11 Above class meets at Morgan Hill Community site. ROP course.

40866	Lec	HOL3	F Mendez	3.9	1.0	M	0600-0935
-------	-----	------	----------	-----	-----	---	-----------

04/25/11 - 05/23/11 Above class meets at the Hollister Briggs site. ROP course.

GUID 530 Job Readiness

Transferable: No

This course is designed to provide a comprehensive, well-organized approach to assist individuals with the identification of occupational choices and the development of job readiness skills necessary to obtain and maintain employment in a competitive or supported work setting. May be repeated twice for credit. This course has the option of a letter grade or pass/no pass.

40423	Lec	BU103	L Franklin	3.2	3.0	MW	0945-1105
-------	-----	-------	------------	-----	-----	----	-----------

This Service Learning section involves community work. See page 19 for more information.

GUID 550 Supervised Tutoring

Transferable: No

Laboratory class emphasizing college learning skills, appropriate study techniques, and learning assistance utilizing one-to-one or small group tutorial.

40172	Lab	Computer Place					
40173	Lab	Digital Media Lab					
40174	Lab	Health Occupations Lab					
40177	Lab	Math Lab					
40178	Lab	Tutoring Center					
40179	Lab	Writing Center					

CRN Type Room Instructor Hrs. Units Days Begin-End

GUID 557 Learning Skills Evaluation

Transferable: No

This course provides an evaluation of the student's cognitive/perceptual abilities and basic skills academic achievement. The evaluation results are used to determine the student's eligibility for Learning Disabilities Services, to develop individual educational plans, and to improve the student's understanding of their own learning strengths and weaknesses. The evaluation is conducted on a one-to-one basis by appointment. Students receive skills training to assist them with their learning difficulties. Units earned in this course do not count toward the associate degree and/or certificate requirements. This is a pass/no pass course.

40424 Lab LI117 L Burgman/ R Overson .5
Make an appointment with the Disability Resource Center (DRC) Office. Open Entry/Open Exit

GUID 558 Learning Skills Laboratory

Transferable: No

The Learning Skills Laboratory is designed to assist students who are eligible to receive Learning Disabilities Services and/or have demonstrated academic deficits. The course content is individualized and based on Student Educational Contracts which are developed for each student. Students receive supplemental instruction, academic support, and learning strategy suggestions appropriate for their individual cognitive, perceptual, and academic strengths and weaknesses. Units earned do not count towards the associate degree and/or certificate requirements. This is a pass/no pass course. ADVISORY: Completion of Guidance 557 or demonstrated academic deficit.

40444	Lab	LI116	R Overson / L Burgman	.5		Open Entry/Open Exit
40472	Lab	LI116	R Overson / L Burgman	1.0		Open Entry/Open Exit
40473	Lab	LI116	R Overson / L Burgman	2.0		Open Entry/Open Exit
40470	Online		R Overson / L Burgman	.5		Open Entry/Open Exit

Start by going to <http://www.gavilan.edu/disted>. You must have an email account to take this course. For help, contact your instructor or email disted@gavilan.edu. Open Entry/Open Exit.

GUID 560 Individualized Learning Skills Development

Transferable: No

This class is designed to teach individual learning skills development to students who are eligible to receive learning disability services. The course content includes organizational skills, fundamental critical thinking and basic college survival skills. ADVISORY: Completion of GUID 557 or demonstrated academic deficit.

40478 Lab BU103 R Overson 3.2 1.0 TR 1120-1240

GUID 562 Directed Study Lab in Pre-Algebra

Transferable: No

This course is designed for students who have demonstrated difficulty in mastering basic mathematics or pre-algebra and who are eligible to receive Learning Disability Services. Course content parallels Mathematics 400 and Mathematics 402. Material is presented in a concrete, multi-sensory manner, and the lab environment allows opportunity for immediate practice, questions, repetition, and review. This is a pass/no pass course. COREQUISITE: Concurrent enrollment in MATH 400 or MATH 402 is required. ADVISORY: Completion of GUID 557 and/or a demonstrated deficit in arithmetic. Recommended for students with verified learning disability.

40477 Lab BU103 L Burgman 3.2 1.0 MW 1120-1240

GUID 563 Directed Study Lab in Algebra

Transferable: No

This course is designed for students who have demonstrated difficulty mastering elementary algebra and who are eligible to receive Learning Disability Services. Course content parallels Mathematics 205A and 205B. Material is presented in a concrete, multi-sensory manner, and the lab allows opportunity for immediate practice, questions, repetition, and review. This is a pass/no pass course. Concurrent enrollment in Math 205A, Math 205B or Math 205 is required.

40479 Lab APE120 L Burgman 3.2 1.0 TR 0945-1105

GUID 565 Directed Study Lab in Intermediate Algebra

Transferable: No

This course is designed for students who have demonstrated difficulty mastering intermediate algebra and who are eligible to receive Learning Disability Services. Course content parallels Mathematics 233A and 233B. Material is presented in a concrete, multi-sensory manner, and the lab allows opportunity for immediate practice, questions, repetition and review. This is a pass/no pass course. Concurrent enrollment in Math 233A, Math 233B or Math 233 is required.

40480 Lab BU103 R Overson 3.2 1.0 TR 0945-1102

Are you a self-confident and self-motivated student?

Become a Rambassador!

Join the Student Ambassador Program and...

- ➔ Join the Outreach and Recruitment Coordinator on local high school visits, at community and on campus events such as GavFest, Science Alive, Transfer Day and Graduation!
- ➔ Learn about college processes, such as admissions, financial aid, registration and Gavilan College's programs and services. Assist new students and make them feel welcome.
- ➔ Help guide visitors on campus tours.

For more information and requirements on becoming a Gavilan College Student Rambassador, please call Lynda Kerr at (408) 846-4993 or e-mail lkerr@gavilan.edu.



The Puente Project is a two-semester program that combines three components: writing, counseling and mentoring to support students to transfer to four-year universities and colleges. The Guidance 6 course focuses on self assessment and career development. The English 1A course focuses on Mexican American/Latino literature. The program also includes a student leadership conference, university visits and mentor/student socials. The program is open to all eligible students. For more information, call Celia Marquez, Puente Co-Coordinator at 408-848-4807.

Required: Complete a program application with the Puente Counselor prior to registration.

GUID 1	CRN 40170	Marquez C	MW	1120A-1240P
Students will need to complete 10 hours of mentoring.				
ENGL1A	CRN 40041	Sandler S	TuTh	1120A -1240P

Rho Alpha Mu



HONOR SOCIETY

Gain eligibility for special scholarships and awards!

Meet other honors students!

Serve the community!

Faculty Advisor,
Jennifer Nari
(408) 848-4897

Must have a GPA of at least 3.0 for twelve units. Incoming freshmen must have attained a 3.5 cumulative GPA from high school.



CRN Type Room Instructor Hrs. Units Days Begin-End

HEALTH EDUCATION

HE 1 Health Education

Transferable: CSU, UC; CSU-GE:E2; GAV-GE:E2

This course focuses on attaining individual awareness, critical-thinking skills and self-responsibility relating to personal health. The interaction of individual physical, psychological, social, emotional, spiritual and environmental factors in determining health status is developed through integration of major concepts. This course has the option of a letter grade or pass/no pass. **ADVISORY:** Eligible for English 250 and English 260.

40052	Lec	LS106	S Dodd	3.2	3.0	TR	0945-1105
	40053	Online	S Quatre	3.0	See information above about online classes.		
	40054	Online	S Quatre	3.0	See information above about online classes.		

HE 2 Human Sexuality

Transferable: CSU, UC; CSU-GE:E2; GAV-GE:E2, F

Assists students in gaining increased knowledge, appreciation, and respect for their own sexuality, as well as others. Approved by the Board of Registered Nursing for 54 hours of continuing education credit (Provider #00892). **ADVISORY:** Eligible for English 250 and English 260

40055	Lec	LS106	R Monaco	3.3	3.0	R	0600-0905
	40056	Online	S Quatre	3.0	See information above about online classes.		

HISTORY

HIST 1 United States History through Reconstruction

Transferable: CSU, UC; CSU-GE:C2, D6, IGETC:3B, 4F, 7B; GAV-GE:C2, D2; CAN:HIST8, HIST SEQ B

History of the United States from the time before European contact with the Americas through Reconstruction. Emphasis will be placed on distinctive patterns of political, economic, social, intellectual, and geographic developments within their global context. At the conclusion of the course, the student should understand major themes in the history of the United States, and be able to explain various ways in which ideas about federal vs. state power, ethnicity, class, and gender divisions have influenced the nation's development. This course has the option of a letter grade or pass/no pass. **ADVISORY:** Eligible for English 250 and English 260.

40287	Lec	PB8	D Kier	3.2	3.0	TR	0810-0930
40286	Lec	PB3	E Luna	3.2	3.0	MW	0945-1105
40285	Lec	MHG12	C Mosher	3.2	3.0	MW	0945-1105
Above class meets at Morgan Hill Community site.							
40289	Lec	HOL2	E Luna	3.2	3.0	TR	1120-1240
Above class meets at the Hollister Briggs site.							
40288	Lec	HOL5	E Luna	3.3	3.0	T	0600-0905
Above class meets at the Hollister Briggs site.							

HIST 2 United States History Reconstruction to the Present

Transferable: CSU, UC; CSU-GE:C2, D6, IGETC:3B, 4F, 7B; GAV-GE:C2, D2; CAN:HIST10, HIST SEQ B

History of the United States from Reconstruction to the present. Emphasis will be placed on distinctive patterns of political, economic, social, intellectual, and geographic developments within their global context. At the conclusion of the course, the student should understand major themes in the history of the United States, and be able to explain various ways in which ideas about federal vs. state power, ethnicity, class, and gender divisions have influenced the nation's development. This course has the option of a letter grade or pass/no pass. **ADVISORY:** Eligible for English 1A.

40293	Lec	PB5	L Halper	3.2	3.0	TR	0945-1105
40294	Lec	HOL2	E Luna	3.2	3.0	TR	0945-1105
Above class meets at the Hollister Briggs site.							
40291	Lec	MHG12	C Mosher	3.2	3.0	MW	1120-1240
Above class meets at Morgan Hill Community site.							
40292	Lec	PB3	L Halper	3.2	3.0	MW	0230-0350
	40295	Online	L Guardino	3.0	See information above about online classes.		

CRN Type Room Instructor Hrs. Units Days Begin-End

 **ONLINE CLASSES:** Start by going to <http://www.gavilan.edu/disted> You must have an email account to take an online course. Unless you have made prior arrangements with the instructor, you **MUST** log on by 11:59 pm on the first day of the course. Late adds must login within 24 hours of adding this course. If you miss the deadline you may be dropped. For help, contact your instructor or email disted@gavilan.edu.

HIST 4A History of World Societies, Before 1500

Transferable: CSU, UC; CSU-GE:C2, D6, IGETC:3B, 4F; GAV-GE:C2, D2

A study of major elements in the development of and interactions between world societies, from the first organization of community to the dawn of the Renaissance. Students will comparatively analyze social, cultural, geographic, economic, demographic, technological, environmental, and political developments that moved humans from nomadic to agri-technological and urban lives. This course has the option of a letter grade or pass/no pass. **ADVISORY:** English 250 and English 260.

40296	Lec	PB8	L Halper	3.2	3.0	TR	1250-0210
-------	-----	-----	----------	-----	-----	----	-----------

HIST 6 Women's Lives in Recent United States History

Transferable: CSU, UC; CSU-GE:C2, D4, D6, IGETC:3B, 4F; GAV-GE:C2, D2

The class examines the construction of womanhood in the US during the twentieth century. The class explores the effects of gender, ethnicity, class, and sexual orientation upon women's experiences. Students will study the contributions of various individual women and groups of women in creating the modern United States, and will analyze social, political, economic, and cultural forces affecting women to both join and resist movements for social change. Students will also learn to apply contemporary feminist theory to traditional historical approaches. **ADVISORY:** English 250

40297	Lec	PB8	L Guardino	3.3	3.0	W	0600-0905
-------	-----	-----	------------	-----	-----	---	-----------

HIST 12 Mexican American Cultural History

Transferable: CSU, UC; CSU-GE:C2, D3, D6, IGETC:3B, 4F; GAV-GE:D2, F

The Mexican American experience as influenced by society in the United States. Emphasis will be on the historical and contemporary contributions made by the Indian, Spanish, Mexican, and Mexican American. Emphasis will also be on the social, economic, and political milieu of the Mexican American within the context of the American society. This course has the option of a letter grade or pass/no pass. This course is also listed as HUM 12. **ADVISORY:** Eligible for English 1A.

40290	Lec	PB3	E Luna	3.2	3.0	MW	1250-0210
-------	-----	-----	--------	-----	-----	----	-----------

HUMANITIES

HUM 4 Introduction to American Cinema

Transferable: CSU, UC; CSU-GE:C2, IGETC:3B; GAV-GE:C2

This introductory course in film studies is a survey of the American film industry as an art form, as an industry, and as a system of representation and communication. The course explores how Hollywood films work technically, aesthetically, and culturally to reinforce and challenge America's national self-image. **ADVISORY:** English 440

	40277	Online	G Richards	3.0	See information above about online classes.		
---	-------	--------	------------	-----	---	--	--

HUM 10 Approaches to Contemporary Film

Transferable: CSU, UC; CSU-GE:C1, C2, IGETC:3B; GAV-GE:C1, C2

Approaches to Contemporary Film examines theories of film criticism as they apply to films from 1960 to the present. Students learn technical, visual, classical, historical, cultural, ideological, and aesthetic approaches to film and sample from a representative list of foreign and domestic movies. Special emphasis is given to new voices from non-American sources and to emerging voices in American cinema. **ADVISORY:** Eligibility for English 250 and 260.

40273	Lec	PB5	G Richards	3.2	3.0	MW	1120-1240
40274	Lec	PB5	G Richards	3.2	3.0	TR	1250-0210

Please help protect Gavilan's park-like setting by properly disposing of litter and recycling.

CRN Type Room Instructor Hrs. Units Days Begin-End

HUM 12 Mexican American Cultural History
 Transferable: CSU, UC; CSU-GE:C2, D3, D6, IGETC:3B, 4F; GAV-GE:D2, F
 The Mexican American experience as influenced by society in the United States. Emphasis will be on the historical and contemporary contributions made by the Indian, Spanish, Mexican, and Mexican American. Emphasis will also be on the social, economic, and political milieu of the Mexican American within the context of the American society. This course has the option of a letter grade or pass/no pass. This course is also listed as HIST 12. ADVISORY: Eligible for English 1A.

40868 Lec PB3 E Luna 3.2 3.0 MW 1250-0210

HUM 23 Independent Study

Transferable: CSU
 Designed to afford selected students specialized opportunities for exploring areas at the independent study level. The courses may involve extensive library work, research in the community, or special projects. May be repeated until six units of credit are accrued. This course has the option of a letter grade or pass/no pass. REQUIRED: The study outline prepared by the student and the instructor must be filed with the department and the dean.

40275 Ind HU111 G Richards 1.0
 40276 Ind HU111 G Richards 1.0

Information Science: see CSIS

Intercollegiate Athletics: see Physical Education

JAPANESE

JPN 1A Elementary Japanese

Transferable: CSU, UC; CSU-GE:C2; GAV-GE:C2
 Beginning course with emphasis on understanding and speaking Japanese; introduction to reading and writing Japanese. This course will also introduce students to Japanese culture and institutions. This course has the option of a letter grade or pass/no pass.

40648 Lec PB14 T Sakai 5.4 5.0 MW 0230-0455
 ARR T Sakai 2.5

JPN 1B Elementary Japanese

Transferable: CSU, UC; CSU-GE:C2, IGETC:6A; GAV-GE:C2
 Continue Japanese 1A with an emphasis on understanding, speaking, reading, and writing Japanese. This course will continue to introduce students to Japanese culture and institutions. This course has the option of a letter grade or pass/no pass. PREREQUISITE: Japanese 1A or equivalent.

40649 Lec PB14 T Sakai 5.4 5.0 TR 0230-0455
 ARR T Sakai 2.5

JPN 23 Independent Study

Transferable: CSU
 Designed to afford selected students specialized opportunities for exploring areas at the independent study level. The course may involve extensive library work, research in the community, or special projects. May be repeated until six units of credit are accrued. This course has the option of a letter grade or pass/no pass. REQUIRED: The study outline prepared by the student and the instructor must be filed with the department and the dean.

40650 Ind PB11 T Sakai 2.0

JOURNALISM

JOUR 10 Mass Media and Society

Transferable: CSU, UC; CSU-GE:C2, D0, IGETC:4J; GAV-GE:C2, D2; CAN:JOUR4
 This course helps students understand the 20th century revolution in mass media by focusing on the history, economics and social impact of the newspaper, book publishing, magazine, film, television, public relations, advertising and music industries. Students will study audience, propaganda and mass communication theory; and discuss new technology, ethnic media in the United States, ethical issues and attempts to regulate or control the media. Honors students will complete more in-depth analysis of media issues and will finish a media-related research project. This course is also listed as SOC 10. This course has the option of a letter grade or pass/no pass. ADVISORY: English 250, English 260.

40565 Lec AR103 J Janes 3.2 3.0 MW 0810-0930



For more information:
 Call us: (408) 612-2057
 Visit our website: www.gavilan.edu/star
 Email us: stargav@gavilan.edu

STAR is a place where kids and staff can feel safe.
 Safe to express their thoughts, ideas and feelings.
 Safe to move and dance and sing.
 Safe to create moments to share.
 Safe to celebrate their lives.
 Safe to grow and develop their potential as performers.
 Safe to laugh, learn and have fun.
 Safe in body, mind and spirit.

Day of Beauty for Men & Women

only \$30
 w/o coupon - \$35

- INCLUDES**
- ✓ Hair cut & style
 - ✓ Deep conditioning
 - ✓ Scalp treatment
 - ✓ Manicure
 - ✓ Facial
 - ✓ Eyebrow arch
 - ✓ Makeup
 - no substitutions*

- DISCOUNTS**
- Senior Citizens: 20% daily
 - Staff/Students: 10% daily
 - Discounts not applicable to DAILY SPECIALS, Special perms or any service under \$6.00

- DAILY SPECIALS**
- | | | |
|-------------------------|----------------------------------|----------------------|
| Wed: | Thurs/Fri: | Wed/Fri: |
| Hair Cut ONLY - \$5.50 | All Basic Perms - 20% off | Hair Color - 20% off |
| Hair Cut & Style - \$10 | Plain Manicure & Pedicure - \$11 | |

For appointments call 408-842-5055

All work performed by students supervised by instructors. Discounts not applicable to daily specials, special color, special perms or any service under \$6. Not valid with any other discounts.

CRN Type Room Instructor Hrs. Units Days Begin-End

JOUR 18A Working on the Newspaper

Transferable: CSU; GAV-GE:C1
 Students interview, write, photograph and do computer assisted design and graphics for the college newspaper, The Gavilan Press. In doing this, they provide the community with an important first amendment forum, learn and educate about the first amendment rights and responsibilities, and acquire journalistic skills, ethics, and habits. ADVISORY: Eligible for English 1A. Typing ability.

40631	Lab	HU106	J Janes	2.6	2.0	MW	0230-0335
40632	Lab	HU106	J Janes	5.4	3.0	MW	0230-0455
40633	Lab	HU106	J Janes	5.4	4.0	MW	0230-0455
	ARR		J Janes	3.3			
40634	Lab	HU106	J Janes	5.4	5.0	MW	0230-0455
	ARR		J Janes	6.6			

CRN Type Room Instructor Hrs. Units Days Begin-End

JOUR 18B Working on the Newspaper

Transferable: CSU; GAV-GE:C1

Students interview, write, photograph and do computer assisted design and graphics for the college newspaper, The Gavilan Press. In doing this, they provide the community with an important first amendment forum, learn and educate about the first amendment rights and responsibilities and acquire journalistic skills, ethics and habits. ADVISORY: Journalism 18A.

40635	Lab	HU106	J Janes	2.6	2.0	MW	0230-0335
40636	Lab	HU106	J Janes	5.4	3.0	MW	0230-0455
40637	Lab ARR	HU106	J Janes J Janes	5.4 3.3	4.0	MW	0230-0455
40638	Lab ARR	HU106	J Janes J Janes	5.4 6.6	5.0	MW	0230-0455

JOUR 18C Working on the Newspaper

Transferable: CSU; GAV-GE:C1

Students interview, write, photograph and do computer assisted design and graphics for the college newspaper, The Gavilan Press. In doing this, they provide the community with an important first amendment forum, learn and educate about the first amendment rights and responsibilities and acquire journalistic skills, ethics and habits. ADVISORY: Journalism 18B.

40639	Lab	HU106	J Janes	2.6	2.0	MW	0230-0335
40640	Lab	HU106	J Janes	5.4	3.0	MW	0230-0455
40641	Lab ARR	HU106	J Janes J Janes	5.4 3.3	4.0	MW	0230-0455
40642	Lab ARR	HU106	J Janes J Janes	5.4 6.6	5.0	MW	0230-0455

JOUR 18D Working on the Newspaper

Transferable: CSU; GAV-GE:C1

Students interview, write, photograph and do computer assisted design and graphics for the college newspaper, The Gavilan Press. In doing this, they provide the community with an important first amendment forum, learn and educate about the first amendment rights and responsibilities and acquire journalistic skills, ethics and habits. ADVISORY: Journalism 18C.

40643	Lab	HU106	J Janes	2.6	2.0	MW	0230-0335
40644	Lab	HU106	J Janes	5.4	3.0	MW	0230-0455
40645	Lab ARR	HU106	J Janes J Janes	5.4 3.3	4.0	MW	0230-0455
40646	Lab ARR	HU106	J Janes J Janes	5.4 6.6	5.0	MW	0230-0455

JOUR 23 Independent Study

Transferable: CSU; GAV-GE:C1

Designed to afford selected students specialized opportunities for exploring areas at the independent study level. The courses may involve extensive library work, research in the community, or special projects. May be repeated until six units of credit are accrued. This course has the option of a letter grade or pass/no pass. REQUIRED: The study outline prepared by the student and the instructor must be filed with the department and the dean.

40647	Ind	HU106	J Janes	2.0			
-------	-----	-------	---------	-----	--	--	--

JOUR 190 Occupational Work Experience/Journalism

Transferable: CSU

Occupational work experience for students who have a job related to their major. A training plan is developed cooperatively between the employer, college and student. (P/NP grading) 75 hours per semester paid work = 1 unit. 60 hours non-paid (volunteer) work per semester = 1 unit. May be taken for a maximum total of 16 units. Minimum 2.00 GPA. REQUIRED: Declared vocational major.

Mandatory course orientation for the following classes will be conducted February 11: 2-3 pm, March 1: 4:30-5:30 pm, April 12: 12 pm. Meetings will be held in the Student Center-North/South Lounge. Students must attend one of the three meetings. www.gavilan.edu/cwe for assignments and details. Please contact Susan Sweeney, CWE Coordinator at ssweeney@gavilan.edu for more information.

40807	Wrk Ex	LI101A	S Sweeney	1.0			
40808	Wrk Ex	LI101A	S Sweeney	2.0			
40809	Wrk Ex	LI101A	S Sweeney	3.0			
40810	Wrk Ex	LI101A	S Sweeney	4.0			

CRN Type Room Instructor Hrs. Units Days Begin-End

JPA Fire Technology and JPA Law Enforcement

see ad below:



Careers in

- Law Enforcement • Fire Technology
- Probation Officer • Dispatcher
- Corrections Officer • Juvenile Hall Counselor

Gavilan College is a member of the South Bay Regional Public Safety Training Consortium. This consortium is funded by all colleges regionally to provide specific vocational training which may require special facilities, special training conditions or is presented outside of the schedules of regular college classes. For more information call 408-270-6458.

Law Enforcement: see also Administration of Justice

LIBRARY

LIB 6 Web Page Authoring I

Transferable: CSU; GAV-GE:E2

A introduction to using Hypertext Mark-Up Language (HTML) and Extensible HTML (XHTML) to create web pages which can be uploaded and displayed on the World Wide Web. Students will use HTML/XHTML to create web pages with text in various sizes and colors, links to other sites, background color or patterns, graphics, tables, and mailto links. Principles of design and color as they apply to screen presentations will be included. This course has the option a letter grade or pass/no pass. May be repeated three times for credit. Also listed as CSIS 6 and DM 6. ADVISORY: CSIS 1 or CSIS 2 or CSIS/LIB 3 advised.

ONLINE:

You must have an email account to take the following two courses. Unless you have made prior arrangements with the instructor, you MUST log on by 11:59 pm on the first day of the course. Late adds must login within 24 hours of adding this course. If you miss the deadline you may be dropped. For help, contact your instructor or email disted@gavilan.edu.

	40827	Online	J Howel	2.0			Start by going to http://www.gavilan.edu/disted 02/07/11 - 03/25/11
	40829	Online	J Howel	2.0			Start by going to http://www.gavilan.edu/disted 03/28/11 - 05/27/11

MANAGEMENT

MGMT 102 Retail Management

Transferable: CSU

Principles and practices used in management of retail businesses such as foods, motels, service stations, and direct channels. Includes site selection, layout, organization, staffing, positioning, customer service, promotional techniques, and all aspects of the critical buying function. This course has the option of a letter grade or pass/no pass. ADVISORY: Eligible for English 250 and English 260.

40821	Lec	BU103	S Kurtz	3.3	3.0	M	0600-0905
-------	-----	-------	---------	-----	-----	---	-----------

MGMT 190 Occupational Work Experience/Management-Supervision

Transferable: CSU

Occupational work experience for students who have a job related to their major. A training plan is developed cooperatively between the employer, college and student. (P/NP grading) 75 hours per semester paid work = 1 unit. 60 hours non-paid (volunteer) work per semester = 1 unit. May be taken for a maximum total of 16 units. Minimum 2.00 GPA. REQUIRED: Declared vocational major.

Mandatory course orientation for the following classes will be conducted February 11: 2-3 pm, March 1: 4:30-5:30 pm, April 12: 12 pm. Meetings will be held in the Student Center-North/South Lounge. Students must attend one of the three meetings. www.gavilan.edu/cwe for assignments and details. Please contact Susan Sweeney, CWE Coordinator at ssweeney@gavilan.edu for more information.

40795	Wrk Ex	LI101A	S Sweeney	1.0			
40796	Wrk Ex	LI101A	S Sweeney	2.0			
40798	Wrk Ex	LI101A	S Sweeney	4.0			

CRN Type Room Instructor Hrs. Units Days Begin-End

MARKETING

MKTG 100 Principles of Marketing

Transferable: CSU

An introduction to the economic and social problems involved with moving goods and services from the producer to the consumer. This course covers topics such as marketing institutions, channels of distribution, pricing, and government relationships. This course has the option of a letter grade or pass/no pass. ADVISORY: Eligible for English 250 and English 260.

40584 Lec BU118 D McCormick 3.2 3.0 MW 1120-1240

MKTG 190 Occupational Work Experience/Marketing

Transferable: CSU

Occupational work experience for students who have a job related to their major. A training plan is developed cooperatively between the employer, college and student. (P/NP grading) 75 hours per semester paid work = 1 unit. 60 hours non-paid (volunteer) work per semester = 1 unit. May be taken for a maximum total of 16 units. Minimum 2.00 GPA. REQUIRED: Declared vocational major.

Mandatory course orientation for the following classes will be conducted February 11:2-3 pm, March 1: 4:30-5:30 pm, April 12: 12 pm. Meetings will be held in the Student Center-North/South Lounge. Students must attend one of the three meetings. www.gavilan.edu/cwe for assignments and details. Please contact Susan Sweeney, CWE Coordinator at ssweeney@gavilan.edu for more information.

40799	Wrk Ex	LI101A	S Sweeney	1.0
40800	Wrk Ex	LI101A	S Sweeney	2.0
40801	Wrk Ex	LI101A	S Sweeney	3.0
40802	Wrk Ex	LI101A	S Sweeney	4.0

MASS COMMUNICATIONS & TELEVISION

Mass Media: see also JOUR 10, Theatre Arts/Television

MCTV 16 Television History and Practice

Transferable: CSU

This course examines theories, history and development of television technology and current distribution practices. Programming genres and production techniques are analyzed, evaluated and compared with other societies as tools of mass communication. This course is also listed as THEA 16. ADVISORY: Eligible for English 250 and 260.

40651 Lec LI144 Abad 3.2 3.0 MW 1120-1240

MCTV 17A Television and Video Workshop

Transferable: CSU

An introduction to television and video technology, including pre-production, production and post-production techniques such as: camera work, studio equipment, lighting, audio plus off-line and on-line editing. This course is also listed as THEA 17A. ADVISORY: Theatre Arts 16 Intro to TV or consent of instructor.

40652 L/L LI144 J Frazier 5.4 3.0 TR 1250-0315

MCTV 17B Television and Video Workshop

Transferable: CSU

Emphasis placed on production and post-production techniques in video production. Student knowledge and skills are increased by participating in live to tape projects. May be repeated twice for credit. This course is also listed as THEA 17B. ADVISORY: Completion of Theatre Arts 17A.

40653 L/L LI144 J Frazier 5.4 3.0 TR 1250-0315

MCTV 19 Television and Film Acting

Transferable: CSU, UC; GAV-GE:C1

Theory and practice of acting for film and television. Students will learn basic performance techniques for the camera. Learning experiences include projects in broadcasting, reporting, commercials, public service announcements (PSA), comedy and drama. This course has the option of a letter grade or pass/no pass. May be repeated three times for credit. This course is also listed as THEA 19.

40858	L/L	LI144	J James R Gonzalez	3.2 3.0	TR	1120-1240
	ARR		TBA	3.2		



Retail Management



Associate's Degree and Certificate of Achievement

Jumpstart your career with Retail Management -- a specially recognized college program designed to prepare individuals for the fast-paced retail industry. The courses help students develop an understanding of the retail manager's job and the requirements for success in the retail environment.

The certificate is composed of ten courses which may be offered in a combination of face to face and distance learning formats.

To complete the Associate's Degree, students must also complete the general education requirements plus sufficient electives to meet a 60 unit total.

Topics include:

- Principles of Marketing
- Introduction to Supervision
- Techniques of Management
- Leadership/Human Relations in Business
- Human Resources Management
- Oral Communications
- Business Communications (written)
- Business Mathematics
- Bookkeeping and Accounting
- Survey of Microsoft Office Programs

Offered this semester:

- MGMT 102**
Retail Management
- MKTG 100**
Principles of Marketing

Questions?
Contact Sherrean Carr,
Dean of Career Technical
Education @ 408-848-4719
or scarr@gavilan.edu.



**MAKE SOMETHING HAPPEN!
LEARN SOMETHING NEW!**

Work in print and online
Earn units toward a Media Arts Degree

Learn new writing, research and design skills
Get published and build a portfolio of your work
Gain work experience that will help you land a good job
Become part of a team
Support free speech at Gavilan College!

JOUR 10 Mass Media & Society

What impact do mass media have on our society and on our world?

JOUR 18A-D Working on the Newspaper

Become a staff member of The Gavilan Press, Gavilan's independent student newspaper, in print and online!