

# Choose a **THEME** for your English class:

Find the number, by the course section number, that corresponds to a theme below.



- 1 Explore consumerism and wild alternatives.
- 2 Explore the great American classics.
- 3 Explore a little basic science and technology on the way to making you a competent, college-level writer.
- 4 Explore the great literature of the human condition, challenging you to respond to literary art, science fiction, music, tragedy and the joy of life and living.
- 5 Focus on the theme of rereading America.
- 6 Focus on the environment, including what we eat and where we live.
- 7 Explore multicultural themes in literature.
- 8 Focus on the theme of examining America.
- 9 Explore modernism in literature.
- 10 Delve into the literature of war.
- 11 Puente: Focus on Mexican American/Latino literature.
- 12 Learn to be a skeptic, ask questions, take nothing for granted and have the courage of your convictions. Not for those convinced that all life's answers lie in the paranormal and supernatural.
- B Explore issues of war and coming of age.

## ENGLISH

### ENGL 1A Composition

**Prerequisite:** English 250 and English 260 or English 250 and SSCI 270A or English 250 and SSCI 270B with a grade of 'C' or better or satisfactory score on the English placement examination.

**Transferable:** CSU; UC; CSU-GE: A2; IGETC: 1A; GAV-GE: A2; CAN: ENGL 2, ENGL SEQ. A

This is a writing course which emphasizes expository writing, argumentative writing, and critical reading of expository prose. It is meant to train students in clear thinking and reasoned support of ideas. Students will be given the opportunity to read models of good expository and argumentative prose and learn the techniques of good writing. These include choosing appropriate subjects, developing restricted, unified, and precise theses and presenting supporting evidence in a logical, lucid, and effective manner. To achieve this end, students write no fewer than six essays and read at least five works, two of which are book length.

4311 LEC ONLINE CHAFFIN C 3.20 3.0 DHR 0000-0000 1 38

 This online class will be delivered entirely over the internet. After enrolling, start the class by going to <http://www.gavilan.edu/disted/>, click on your class link and email the instructor at [cchaffin@gavilan.edu](mailto:cchaffin@gavilan.edu). Students who have not begun the class or contacted the instructor by 5 pm on Feb. 4 will be dropped from the class.

4312 LEC ONLINE CHAFFIN C 3.30 3.0 DHR 0000-0000 1 38

 This online class will be delivered entirely over the internet. After enrolling, start the class by going to <http://www.gavilan.edu/disted/>, click on your class link and email the instructor at [cchaffin@gavilan.edu](mailto:cchaffin@gavilan.edu). Students who have not begun the class or contacted the instructor by 5 pm on Feb. 4 will be dropped from the class.

4313 LEC SS111 PIRANI A 3.20 3.0 MW 0810A-0930A 1

4314 LEC HU103 MCMILLEN J 3.20 3.0 TuTh 0810A-0930A 1

5 4315 LEC MHG4 GATEWOOD J 3.20 3.0 TuTh 1250P-0210P 1  
Above class meets at Morgan Hill Community site

4316 LEC HU103 WISDOM K 3.20 3.0 MW 0945A-1105A 1

4317 LEC HOL2 MORA G 3.20 3.0 MW 1120A-1240P 1  
Above class meets at the Hollister Briggs site

4318 LEC HU103 MCMILLEN J 3.20 3.0 TuTh 0945A-1105A 1

B 4319 LEC HU103 JACKSON S 3.30 3.0 F 0945A-1250P 1

6 4320 LEC HU103 SALVIN C 3.20 3.0 MW 1120A-1240P 1

B 4322 LEC SS203 JACKSON S 3.20 3.0 TuTh 1250P-0210P 1

4323 LEC HU103 WILSON J 3.20 3.0 MW 0230P-0350P 1

B 4324 LEC HU103 JACKSON S 3.20 3.0 TuTh 0400P-0520P 1

4325 ONLINE/HU102 CROOK E 3.30 3.0 Th 1120A-1240P 13

 This HYBRID lecture/online class will be delivered partially over the Internet. See the online syllabus for details. <http://www.gavilan.edu/disted/>

3 6088 LEC HOL2 BRETT T 3.30 3.0 M 0600P-0905P 1  
Above class meets at the Hollister Briggs site

6089 LEC HU103 PIRANI A 3.30 3.0 Tu 0600P-0905P 1

6090 LEC MHG3 MCMILLEN J 3.30 3.0 Th 0600P-0905P 1  
Above class meets at Morgan Hill Community site

#### PUENTE LEARNING COMMUNITY SECTION:

11 4321 LEC SS203 SANDLERS 3.20 3.0 TuTh 1120A-1240P 182

### ENGL 1B Composition and Literature

**Prerequisite:** English 1A with a grade of "C" or better.

**Transferable:** CSU; UC; CSU-GE: C ; IGETC: 3B; GAV-GE: C2; CAN: ENGL 4, ENGL SEQ. A

English 1B continues the work begun in 1A, but now the emphasis shifts to writing expository prose in conjunction with reading and analyzing imaginative literature. Students are to write as fledgling critics and use the text as a basis for other forms of reflection. The reading requirement includes short stories, poetry, drama, and at least two novels. Course work will also include fundamentals of research writing.

4326 LEC ONLINE WISDOM K 3.30 3.0 DHR 0000-0000 1 38

 This online class will be delivered entirely over the internet. After enrolling, start the class by going to <http://www.gavilan.edu/disted/>, click on your class link and email the instructor at [kwisdom@gavilan.edu](mailto:kwisdom@gavilan.edu). Students who have not begun the class or contacted the instructor by 5 pm on Feb. 4 will be dropped from the class.

9 4327 LEC ONLINE HOOPER J 3.30 3.0 DHR 0000-0000 1 38 61

 This online class will be delivered entirely over the internet. After enrolling, start the class by going to <http://www.gavilan.edu/disted/>, click on your class link and email the instructor at [jhooper@gavilan.edu](mailto:jhooper@gavilan.edu). Students who have not begun the class or contacted the instructor by 5 pm on Feb. 4 will be dropped from the class. Students must attend a mandatory orientation on Thursday, February 1, 2008 from 3:30 – 5:00 pm in LI171.

10 4328 LEC MHG10 ORAL M 3.20 3.0 TuTh 0810A-0930A 1  
Above class meets at Morgan Hill Community site

4329 LEC HU102 RICHARDS G 3.20 3.0 TuTh 0945A-1105A 1

2 4330 LEC HU102 LUOMA D 3.30 3.0 F 0945A-1250P 1

4331 LEC HU102 CROOK E 3.20 3.0 MW 1120A-1240P 1

2 4332 LEC HU102 LUOMA D 3.20 3.0 MW 1250P-0210P 1

10 4333 LEC HU103 ORAL M 3.20 3.0 TuTh 0230P-0350P 1

4 6091 LEC HU102 BRETT T 3.30 3.0 Th 0600P-0905P 1

### ENGL 1C Critical Reasoning and Writing

**Prerequisite:** English 1A with a grade of "C" or better.

**Transferable:** CSU; UC; CSU-GE: A3; IGETC: 1B; GAV-GE: C2

This course is designed to develop critical thinking, reading, and writing skills beyond the level achieved in English 1A. The emphasis is on critical analysis of arguments and the development of the ability to integrate the principles of critical thinking into essay writing.

4334 LEC ONLINE STAFF 3.30 3.0 DHR 0000-0000 1

 This online class will be delivered entirely over the internet. After enrolling, start the class by going to <http://www.gavilan.edu/disted/>, click on your class link and email the instructor at [jhowell@gavilan.edu](mailto:jhowell@gavilan.edu). Students who have not begun the class or contacted the instructor by 5 pm on Feb.4 will be dropped from the class.

4335 LEC HU102 WISDOM K 3.20 3.0 MW 0810A-0930A 1

4336 LEC HOL2 MORA G 3.20 3.0 MW 0945A-1105A 1  
Above class meets at the Hollister Briggs site

4337 LEC HU102 CONDON D 3.20 3.0 TuTh 1250P-0210P 1

4338 LEC HU102 LUOMA D 3.20 3.0 MW 0230P-0350P 1

4339 LEC HU102 ORAL M 3.20 3.0 TuTh 0400P-0520P

12 6092 LEC HU103 BRETT T 3.30 3.0 W 0600P-0905P 1

## Spring 2008 Schedule

Sect. Type Room Instructor Hrs. Units Days Begin-End Footnotes

**ENGL 2C Introduction to Film and Fiction****Prerequisite:** Eligible for English 1A.**Transferable:** CSU; UC; CSU-GE: C2; IGETC: 3B; GAV-GE: C2

This is a literature course in analysis of the novel and film as art forms. The student will read several novels, view the films based on the novels, and discuss the difference in techniques, both orally and in writing.

6093 LEC SS214 RICHARDS G 3.30 3.0 W 0630P-0935P

**ENGL 2F Children's Literature****Prerequisite:** English 1A.**Transferable:** CSU; UC; CSU-GE: C2; IGETC: 3B; GAV-GE: C2

A survey of texts for elementary and intermediate grades, with a focus on literary analysis, criticism and evaluation. Study of historical backgrounds and development of genres of children's literature in a cross section of cultures. This course has the option of a letter grade or credit/no credit.

4340 ONLINE/HU102 CROOKE 3.30 3.0 Tu 1120A-1240P 13



This HYBRID lecture/online class will be delivered partially over the Internet. See the online syllabus for details. <http://www/gavilan.edudisted/>

**ENGL 5B Survey of American Literature - 1865 to Present****Prerequisite:** Eligible for English 1A.**Transferable:** CSU; UC; CSU-GE: C2; IGETC: 3B; GAV-GE: C2; CAN: ENGL 16, ENGL SEQ. C

This course is a study of the masters of American literature covering the years 1865 A.D. to the present. Note: Need not be taken in sequence.

4341 LEC SS110 STAFF 3.30 3.0 TuTh 1120A-1240P

**ENGL 9A Introduction to Creative Writing****Prerequisite:** Eligible for English 1A.**Transferable:** CSU; UC; CSU-GE: C2; GAV-GE: C2; CAN: ENGL 6

This course includes the writing, reading, and critical discussions of various forms of poetry and fiction.

4342 LEC SS111 SANDLER S 3.20 3.0 MW 1120A-1240P

6094 LEC HOL6 SALVIN C 3.30 3.0 Th 0600P-0905P  
Above class meets at the Hollister Briggs site**ENGL 9B Advanced Creative Writing****Prerequisite:** English 9A with a grade of credit or C or better.**Transferable:** CSU; UC; CSU-GE: C2; GAV-GE: C2

This class is a continuation of English 9A, with the emphasis shifting to publication. The genre of non-fiction will be the primary focus, but the genres of fiction will also be taught at a more comprehensive level than in English 9A. The process of finding a market for one's work will be followed step by step. The class may compile and publish "Soaring", Gavilan's literary magazine, each spring semester.

4343 LEC SS111 SANDLER S 3.20 3.0 MW 1120A-1240P

6095 LEC HOL6 SALVIN C 3.30 3.0 Th 0600P-0905P  
Above class meets at the Hollister Briggs site**ENGL 9C Poetry Writing****Prerequisite:** English 9A with a grade or credit or C or better.**Transferable:** CSU; UC; CSU-GE: C2; GAV-GE: C2

This course includes the writing, reading, and critical discussions of various forms of poetry.

4344 LEC SS111 SANDLER S 3.20 3.0 MW 1120A-1240P

6096 LEC HOL6 SALVIN C 3.30 3.0 Th 0600P-0905P  
Above class meets at the Hollister Briggs site

## Introduction to Film & Fiction

### ENGL 2C

Instructor - Grant Richards

*The DaVinci Code*  
*Pride and Prejudice*  
*Million Dollar Baby*  
*Mystic River*  
*A History of Violence*  
*Cold Mountain*  
*Sideways*  
*Motorcycle Diaries*  
*Closer*  
*Fight Club*  
*Notebook*  
*High Fidelity*  
*The Shawshank Redemption*  
*To Kill a Mockingbird*  
*One Flew Over the Cuckoo's Nest*  
*Chocolat*  
*LA Confidential*  
*Get Shorty*  
*and more!*

*This class can fulfill your IGETC humanities transfer requirement.*



*This HYBRID lecture/online class will be delivered partially over the Internet.*

*See the online syllabus for details.*

*<http://www/gavilan.edudisted/>*



ENGL 2F  
CHILDREN'S  
LITERATURE

Instructor: Erin Crook



## ENGL 5B

## Survey of American Literature

### 1865 to Present

*Satisfies the humanities requirement under the IGETC, the CSU-GE Breadth and the AA/AS Degree patterns.*

**Footnotes contain valuable information pertaining to your class selection. Footnotes follow class listings.**

Sect. Type Room Instructor Hrs. Units Days Begin-End Footnotes

**ENGL 12A Tutoring Writers: Training/Theory & Practice**

Advisory: Eligible for English 1A.  
Transferable: CSU

Fundamentals of compositional theory, the writing process, peer-to-peer communication, interacting with faculty and educational institutions and effective responses to writing will be covered. In addition, students will gain an understanding of the basic history, methodology and practice of writing pedagogy while developing a writing community that aids in connecting them to their own writing practice.

4345 LEC LI120 SMITH K 1.00 1.0 M 0230P-0400P

**ENGL 12B Tutoring Writers: Training/Theory & Practice**

Advisory: Eligible for English 1A.  
Transferable: CSU

Fundamentals of compositional theory, the writing process, peer-to-peer communication, interacting with faculty and educational institutions and effective responses to writing will be covered. In addition, students will gain an understanding of the basic history, methodology and practice of writing pedagogy while developing a writing community that aids in connecting them to their own writing practice.

4346 LEC LI120 SMITH K 1.00 1.0 M 0230P-0400P

**ENGL 12C Tutoring Writers: Training/Theory & Practice**

Advisory: Eligible for English 1A.  
Transferable: CSU

Fundamentals of compositional theory, the writing process, peer-to-peer communication, interacting with faculty and educational institutions and effective responses to writing will be covered. In addition, students will gain an understanding of the basic history, methodology and practice of writing pedagogy while developing a writing community that aids in connecting them to their own writing practice.

4347 LEC LI120 SMITH K 1.00 1.0 M 0230P-0400P

**ENGL 12D Tutoring Writers: Training, Theory & Practice**

Advisory: Eligible for English 1A.  
Transferable: CSU

Fundamentals of compositional theory, the writing process, peer-to-peer communication, interacting with faculty and educational institutions and effective responses to writing will be covered. In addition, students will gain an understanding of the basic history, methodology and practice of writing pedagogy while developing a writing community that aids in connecting them to their own writing practice.

4348 LEC LI120 SMITH K 1.00 1.0 M 0230P-0400P

**ENGL 23 Independent Study**

Required: The study outline prepared by the student and the instructor must be filed with the department and the dean.

Transferable: CSU

Designed to afford selected students specialized opportunities for exploring areas at the independent study level. The courses may involve extensive library work, research in the community, or special projects. May be repeated until six units of credit are accrued. This course has the option of a letter grade or credit/no credit.

4349 IND LI120 SMITH K 6.80 2.0 DHR 0000-0000 22

4350 IND LI120 SMITH K 3.30 1.0 DHR 0000-0000 22

Sect. Type Room Instructor Hrs. Units Days Begin-End Footnotes

**ENGL 250 Practical Writing**

Prerequisite: English 440 or ESL 563 with a grade of 'C' or better or satisfactory score on the English placement examination.

Transferable: No; GAV-GE: A2

**1 2 3** Your ENGL 250 class has a theme. See list on page 62.

This course covers writing clear, correct, effective essays and learning preliminary research skills.

4351 L/L SS203 TICE R 4.20 3.0 MW 0810A-0930A 1  
LI120 TICE R F 0810A-0900A

4352 L/L SS203 TICE R 4.20 3.0 MW 0810A-0930A 1  
LI120 TICE R F 0910A-1000A

4353 L/L SS203 STAFF 4.20 3.0 TuTh 0810A-0930A 1  
LI120 STAFF M 0810A-0900A

4354 L/L SS203 STAFF 4.20 3.0 TuTh 0810A-0930A 1  
LI120 STAFF W 0810A-0900A

**1** 4355 L/L HU102 SALVIN C 4.20 3.0 MW 0945A-1105A 1  
LI171 SALVIN C M 0845A-0935A

**1** 4356 L/L HU102 SALVIN C 4.20 3.0 MW 0945A-1105A 1  
LI171 SALVIN C W 0845A-0935A

**1** 4357 L/L HOL6 SALVIN C 4.20 3.0 TuTh 0945A-1105A 1  
SALVIN C Tu 0845A-0935A

Above class meets at the Hollister Briggs site

**1** 4358 L/L HOL6 SALVIN C 4.20 3.0 TuTh 0945A-1105A 1  
SALVIN C Th 0845A-0935A

Above class meets at the Hollister Briggs site

4359 L/L SS203 CONDON D 4.20 3.0 TuTh 0945A-1105A 1  
LI171 CONDON D Tu 1120A-1210P

4360 L/L SS203 CONDON D 4.20 3.0 TuTh 0945A-1105A 1  
LI171 CONDON D Th 1120A-1210P

**3** 4361 L/L MHG11 GATEWOOD J 4.20 3.0 TuTh 1120A-1240P 1  
GATEWOOD J Tu 0845A-0935A

Above class meets at Morgan Hill Community site

**3** 4362 L/L MHG11 GATEWOOD J 4.20 3.0 TuTh 1120A-1240P 1  
GATEWOOD J Th 1010A-1100A

Above class meets at Morgan Hill Community site

4365 L/L SS111 WILSON J 4.20 3.0 MW 1250P-0210P 1  
LI120 WILSON J M 1150A-1240P

4366 L/L SS111 WILSON J 4.20 3.0 MW 1250P-0210P 1  
LI120 WILSON J W 1150A-1240P

4369 L/L SS203 DRAEGAN K 4.20 3.0 TuTh 0230P-0350P 1  
SS111 DRAEGAN K M 0230P-0320P

4370 L/L SS203 DRAEGAN K 4.20 3.0 TuTh 0230P-0350P 1  
SS111 DRAEGAN K W 0230P-0320P

**7** 4371 L/L SS203 STAFF 4.20 3.0 MW 0400P-0520P 1  
LI171 STAFF M 0300P-0350P

**7** 4372 L/L SS203 STAFF 4.20 3.0 MW 0400P-0520P 1  
LI171 STAFF W 0300P-0350P

6097 L/L SS203 GARDNER L 4.20 3.0 M W 0700P-0820P 1  
GARDNER L W 0830P-0920P

6098 L/L SS203 GARDNER L 4.20 3.0 M W 0700P-0820P 1  
GARDNER L M 0830P-0920P

6099 L/L HOL5 PARKER V 4.20 3.0 TuTh 0700P-0820P 1  
HOL5 PARKER V Tu 0830P-0920P

Above class meets at the Hollister Briggs site

6100 L/L HOL5 PARKER V 4.20 3.0 TuTh 0700P-0820P 1  
HOL6 PARKER V Th 0830P-0920P

Above class meets at the Hollister Briggs site

FIRST YEAR EXPERIENCE SECTIONS:

4363 L/L PB5 SMITH K 4.20 3.0 TuTh 1120A-1240P 1 78  
LI120 SMITH K Tu 0110P-0200P

4364 L/L PB5 SMITH K 4.20 3.0 TuTh 1120A-1240P 1 78  
LI120 SMITH K Th 0110P-0200P

4367 L/L HU103 HOOPER J 4.20 3.0 TuTh 1250P-0220P 1 78  
LI120 HOOPER J Tu 1010A-1100A

4368 L/L HU103 HOOPER J 4.20 3.0 TuTh 1250P-0220P 1 78  
LI120 HOOPER J Th 1010A-1100A

Have you met the prerequisite?  
**It's required!**

Sect. Type Room Instructor Hrs. Units Days Begin-End Footnotes

**ENGL 260 Preparation for College Reading**

**Prerequisite:** Completion of English 420 or ESL 562 with a grade of 'C' or better or Assessment recommendation.  
**Transferable:** No; GAV-GE: A3

This is a course presenting strategies in the technique and practice of college level critical reading and thinking skills.

**1 2 3** Your ENGL 260 class has a theme. See list on page 62.

4373	LEC	HU102	HULL K	3.20	3.0	TuTh	0810A-0930A	1
4374	LEC	SS203	HULL K	3.20	3.0	MW	0945A-1105A	1
4377	LEC	SS203	HIRASUNA S	3.30	3.0	F	0945A-1250P	1
4380	LEC	SS203	HULL K	3.20	3.0	MW	1250P-0210P	1
6101	LEC	SS203	GARDNER L	3.20	3.0	M W	0530P-0650P	1
6102	LEC	HOL5	PARKER V	3.20	3.0	TuTh	0530P-0650P	1

Above class meets at the Hollister Briggs site

**FIRST YEAR EXPERIENCE SECTIONS:**

4375	LEC	PB5	SMITH K	3.20	3.0	TuTh	0945A-1105A	1 73
4376	LEC	PB5	SMITH K	3.20	3.0	TuTh	0945A-1105A	1 73
4378	LEC	HU103	HOOPER J	3.20	3.0	TuTh	1120A-1240P	1 73
4379	LEC	HU103	HOOPER J	3.20	3.0	TuTh	1120A-1240P	1 73

**ENGL 420 Reading Improvement**

**Prerequisite:** Satisfactory score on the English placement examination.  
**Transferable:** No

This is a practical, "how to" course teaching various methods of learning and reading college material. Using group and individual instruction in vocabulary, comprehension, and study skills, the students will increase their ability to survive academically, to profit, grow and succeed in all college courses, and to enjoy reading and learning. Units earned in this course do not count toward the associate degree and/or certain certificate requirements.

4381	L/L	SS111 SS216	WITHERS M WITHERS M	4.20	3.0	TuTh Tu	0810A-0930A 0945A-1035A	1
4382	L/L	SS111 SS216	WITHERS M WITHERS M	4.20	3.0	TuTh Th	0810A-0930A 0945A-1035A	1
4383	L/L	HOL2	RAIMONDO J RAIMONDO J	4.20	3.0	TuTh F	0945A-1105A 1010A-1100A	

Above class meets at the Hollister Briggs site

4384	L/L	HOL2	RAIMONDO J RAIMONDO J	4.20	3.0	TuTh F	0945A-1105A 1110A-1200P	
------	-----	------	--------------------------	------	-----	-----------	----------------------------	--

Above class meets at the Hollister Briggs site

4385	L/L	SS111 HU104	WITHERS M WITHERS M	4.20	3.0	TuTh Th	1120A-1240P 1250P-0140P	1
4386	L/L	SS111 HU104	WITHERS M WITHERS M	4.20	3.0	TuTh Tu	1120A-1240P 1250P-0140P	1
4387	L/L	HU103 SS216	HOOPER J HOOPER J	4.20	3.0	MW M	1250P-0210P 0230P-0320P	1
4388	L/L	HU103 SS216	HOOPER J HOOPER J	4.20	3.0	MW W	1250P-0210P 0230P-0320P	1
6103	L/L	SS111	ARORA S ARORA S	4.20	3.0	M W M	0600P-0720P 0730P-0820P	
6104	L/L	SS111	ARORA S ARORA S	4.20	3.0	M W W	0600P-0720P 0730P-0820P	

**ENGL 439 Basic Grammar and Reading**

**Advisory:** Assessment recommendation.  
**Transferable:** No

This is a remediation course introducing basic reading and writing strategies, as well as study skills. Group and individual instruction will be used to build vocabulary, increase reading comprehension, develop study skills, and apply basic grammar to writing. Units earned in this course do not count toward the associate degree and/or certain certificate requirements. This is a credit/no credit course.

4389	L/L	SS111	TICE R SMITH K L120	6.40	4.0	MW TBA F	0945A-1105A 0000-0000 1010A-1215P	
------	-----	-------	---------------------------	------	-----	----------------	---	--

**English 9A, B, C**

**CREATIVE Writing**



John Updike photograph by Jill Krementz

Creative Writing classes allow students to express themselves through writing in a variety of modes: fiction, poetry, drama, and creative non-fiction.

Students will work both individually and in collaborative group activities, as well as respond to each other's work through supportive classroom workshops. Over the course of the semester, students will generate enough material to create a portfolio of their own work.

 Sects. 6094, 6095, 6096  
 Thursday evening in Hollister  
 from 6:00 pm - 9:05 pm  
 with Christina Salvin

 Sects. 4342, 4343, 4344  
 Monday/Wednesday  
 from 11:20 am - 12:40 pm  
 with Scott Sandler

*This class fulfills your CSU humanities transfer requirement.*



The Puente Project is a two-semester program that combines three components: writing, counseling and mentoring to support students to transfer to four-year universities and colleges. The Guidance 6 course focuses on life skills for higher education and transfer. The English 250 course focuses on Mexican American/Latino literature. The program also includes a student leadership conference, university visits and mentor/student socials. The program is open to all eligible students. For more information, call Celia Marquez, Puente Co-Coordinator at 408-848-4807.

**Required:** Complete a program application with the Puente Counselor prior to registration.

**ENGL 1A Composition**

4321	LEC	SS203	SANDLER S	3.20	3.0	TuTh	1120A-1240P	1 82
------	-----	-------	-----------	------	-----	------	-------------	------

**GUID 1 Self Assessment and Career Development**

4433	LEC	PB5	MARQUEZ C	2.30	2.0	M	1120A-0125P	39 50 89
------	-----	-----	-----------	------	-----	---	-------------	----------

Additional meeting required on Wednesdays from 11:20 am -12:10 pm in PB7.

Sect. Type Room Instructor Hrs. Units Days Begin-End Footnotes

**ENGL 440 Basic Writing**

**Prerequisite:** Satisfactory score on the English placement examination.  
**Transferable:** No

This is an intensive study and application of basic grammar, sentence, and essay writing skills within the context of composing short essays. Units earned in this course do not count toward the associate degree and/or certain certificate requirements.

4390	L/L	HU103 LI171	SANDLER S SANDLER S	4.20 3.0	MW M	0810A-0930A 0945A-1035A	1
4391	L/L	HU103 LI171	SANDLER S SANDLER S	4.20 3.0	MW W	0810A-0930A 0945A-1035A	1
4392	L/L	HOL2	RAIMONDO J RAIMONDO J	4.20 3.0	TuTh F	0810A-0930A 0810A-0900A	1
Above class meets at the Hollister Briggs site							
4393	L/L	HOL2	RAIMONDO J RAIMONDO J	4.20 3.0	TuTh F	0810A-0930A 0910A-1000A	1
Above class meets at the Hollister Briggs site							
4394	L/L	SS111 LI120	SANDLER S SANDLER S	4.20 3.0	TuTh Tu	0945A-1110A 0845A-0935A	1
4395	L/L	SS111 LI120	SANDLER S SANDLER S	4.20 3.0	TuTh Th	0945A-1110A 0845A-0935A	1
4396	L/L	SS203 LI120	STAFF STAFF	4.20 3.0	MW Tu	1120A-1240P 1120A-1210P	1
4397	L/L	SS203 LI120	STAFF STAFF	4.20 3.0	MW Th	1120A-1240P 1120A-1210P	1
4398	L/L	SS111 LI120	DRAEGANK DRAEGANK	4.20 3.0	TuTh M	1250P-0210P 1250P-0140P	1
4399	L/L	SS111 LI120	DRAEGANK DRAEGANK	4.20 3.0	TuTh W	1250P-0210P 1250P-0140P	1
6105	L/L	SS111	ARORA S ARORA S	4.20 3.0	TuTh Tu	0600P-0720P 0730P-0820P	
6106	L/L	SS111	ARORA S ARORA S	4.20 3.0	TuTh Th	0600P-0720P 0730P-0820P	

Sect. Type Room Instructor Hrs. Units Days Begin-End Footnotes

**ENGLISH AS A SECOND LANGUAGE**

All new ESL students must go through the ESL assessment process. See page 126.

Todos los nuevos estudiantes de ESL deben tomar el examen de nivelación de ESL. Consulte la página 126.

**ESL 501 Survival ESL I**

**Advisory:** ESL assessment recommendation  
**Transferable:** No

This is a course in survival English for students with little or no oral or written English competency. It will give students basic vocabulary and familiarity in life skill areas such as the family, food, health, and occupations. The course integrates listening, speaking, reading, and writing. (ESL 501, 502, and 503 are sequential courses that may be taken in full form or in halves, preferably A before B.) This is a credit/no credit course.

4406	L/L	HOL4	GUZMAND	11.30 6.0	DAILY	0910A-1105A
Above class meets at the Hollister Briggs site						

**ESL 501A Survival ESL I First Half**

**Advisory:** ESL assessment recommendation  
**Transferable:** No

This is the first half of a course in survival English for students with little or no oral or written English competency. It will give students basic vocabulary and familiarity in life skill areas such as the family, food, health, and occupations. The course integrates listening, speaking, reading, and writing. (ESL 501, 502, and 503 are sequential courses that may be taken in full form or in halves, preferably A before B.) This is a credit/no credit course.

6111	L/L	HOL4	DIEHL K	5.70 3.0	M WF	0600P-0730P
Above class meets at the Hollister Briggs site						

6112	L/L	HU101	STAFF	5.70 3.0	M W	0630P-0855P
------	-----	-------	-------	----------	-----	-------------

**ESL 501B Survival ESL I Second Half**

**Advisory:** ESL 501A or ESL assessment recommendation  
**Transferable:** No

This is a second half of a course in survival English for students with little or no oral or written English competency. It will give students basic vocabulary and familiarity in life skill areas such as the family, food, health, and occupations. The course integrates listening, speaking, reading, and writing. (ESL 501, 502, and 503 are sequential courses that may be taken in full form or in halves, preferably A before B.) This is a credit/no credit course.

6113	L/L	HU101	STAFF	5.70 3.0	TuTh	0630P-0855P
------	-----	-------	-------	----------	------	-------------

**The Final Word!**

Look for the Final Exams schedule on page 105 of this schedule.

**ENGLISH COMPOSITION AND READING COURSE SEQUENCE**

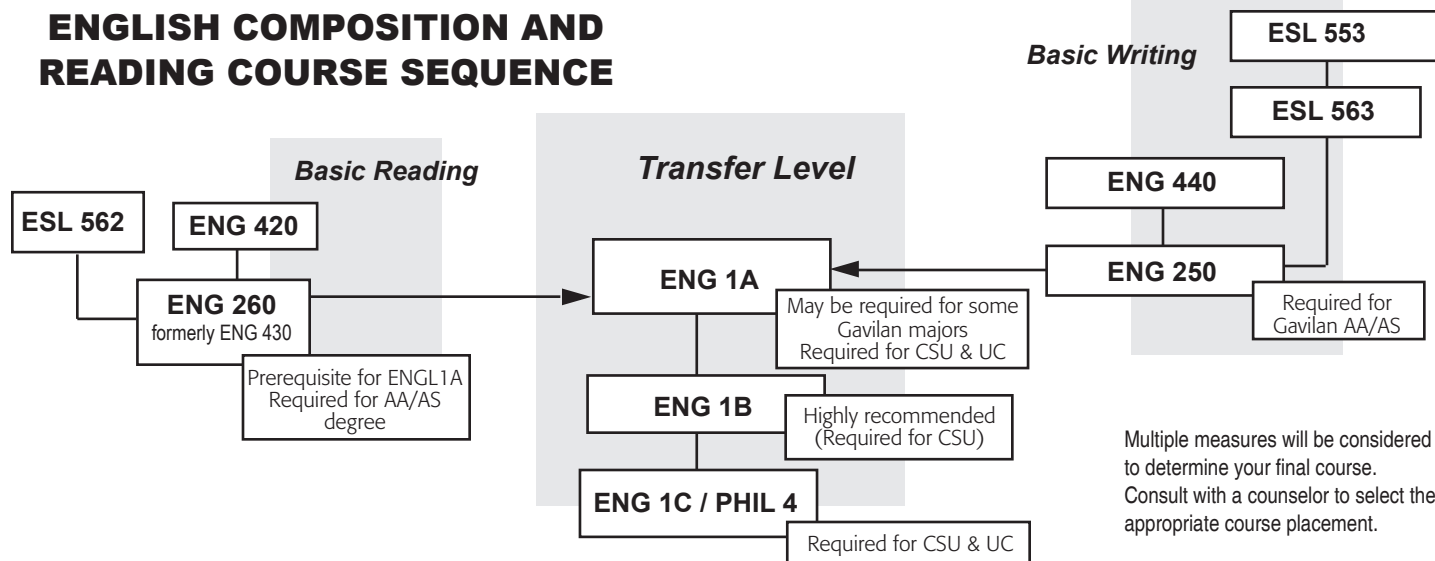

Multiple measures will be considered to determine your final course. Consult with a counselor to select the appropriate course placement.

Spring 2008 Schedule

Sect. Type Room Instructor Hrs. Units Days Begin-End Footnotes

**ESL 502 Survival ESL II**

**Advisory:** ESL 501 or ESL 501A and 501B or ESL assessment recommendation  
**Transferable:** No

This is a second course in survival English for students with little oral or written English competency. It will give students expanded basic vocabulary and familiarity in life skill areas such as the weather, transportation, employment, and American holidays and customs. The course integrates listening, speaking, reading, and writing. (ESL 501, 502, and 503 are sequential courses that may be taken in full form or in halved, preferably A before B.) This is a credit/no credit course.

4407 L/L HOL4 POLIZZOTTO J 11.30 6.0 DAILY 1115A-0110P  
 Above class meets at the Hollister Briggs site

**ESL 502A Survival ESL II First Half**

**Advisory:** ESL 501 or ESL 501A and 501B or ESL assessment recommendation  
**Transferable:** No

This is the first half of a second course in survival English for students with little oral or written English competency. It will give students expanded basic vocabulary and familiarity in life skill areas such as the weather, transportation, employment, and American holidays and customs. The course integrates listening, speaking, reading, and writing. (ESL 501, 502, and 503 are sequential courses that may be taken in full form or in halves, preferably A before B.) This is a credit/no credit course.

6114 L/L HOL6 HOWELL J A 5.70 3.0 M WF 0600P-0730P  
 Above class meets at the Hollister Briggs site

6115 L/L HU104 MAXWELL K 5.70 3.0 M W 0630P-0855P

**ESL 502B Survival ESL II Second Half**

**Advisory:** ESL 501 or ESL 501A and 501B or ESL assessment recommendation  
**Transferable:** No

This is the second half of the second course in survival English for students with little oral or written English competency. It will give students expanded basic vocabulary and familiarity in life skill areas such as weather, transportation, employment, and American holidays and customs. The course integrates listening, speaking, reading, writing. (ESL 501, 502, and 503 are sequential courses that may be taken in full form or in halves, preferably A before B.) This is a credit/no credit course.

6116 L/L HU104 STAFF 5.70 3.0 TuTh 0630P-0855P

6117 L/L HOL4 HOWELL J A 5.70 3.0 M WF 0745P-0915P  
 Above class meets at the Hollister Briggs site

**ESL 503A Survival ESL III First Half**

**Advisory:** ESL 502 or ESL 502A and 502B or ESL assessment recommendation  
**Transferable:** No

This is the first half of a third course in survival English for students with beginning oral or written English competency. It will reinforce basic skills learned and continue to develop vocabulary and ease of communication in life skill areas such as the family, the larger community, health, employment, and leisure activities. The course integrates listening, speaking, reading, and writing. (ESL 501, 502, and 503 are sequential courses that may be taken in full form or in halves, preferably A before B.) This is a credit/no credit course.

6118 L/L LI100 SHELLEY A 5.70 3.0 M W 0630P-0855P

**ESL 503B Survival ESL III Second Half**

**Advisory:** ESL 502 or ESL 502A and 502B or ESL assessment recommendation  
**Transferable:** No

This is the second half of a third course in survival English for students with beginning oral or written English competency. It will reinforce basic skills learned and continue to develop vocabulary and ease of communication in life skill areas such as the family, the larger community, health, employment, and leisure activities. The course integrates listening, speaking, reading, and writing. (ESL 501, 502, and 503 are sequential courses that may be taken in full form or in halves, preferably A before B.) This is a credit/no credit course.

6119 L/L HOL6 DIEHL K 5.70 3.0 M WF 0745P-0915P  
 Above class meets at the Hollister Briggs site



**Is this your first year at Gavilan? Looking for a community of people like you? Then this learning community program is specially designed for you.** The first year of college can be challenging for many students. By studying and working together with your classmates and instructors, in this program you'll develop a strong network of support to help you succeed. You'll improve your reading and writing skills and also explore options for majors, transferring, and careers. Building a strong foundation in your first year will put you on the road to success throughout your college experience.

**The Program:** Students will take reading, writing and guidance together because these skills are needed to succeed in college classes.

**The following classes are part of a First Year Experience learning community. You must enroll in all three courses.**

**ENGL 260 Preparation for College Reading**  
 4376 LEC PB5 SMITH K 3.20 3.0 TuTh 0945A-1105A 1

**ENGL 250 Practical Writing**  
 4363 L/L PB5 SMITH K 4.20 3.0 TuTh 1120A-1240P 1  
 LI120 SMITH K Tu 0110P-0200P

\_\_\_\_\_ or \_\_\_\_\_

**ENGL 260 Preparation for College Reading**  
 4375 LEC PB5 SMITH K 3.20 3.0 TuTh 0945A-1105A 1

**ENGL 250 Practical Writing**  
 4364 L/L PB5 SMITH K 4.20 3.0 TuTh 1120A-1240P 1  
 LI120 SMITH K Th 0110P-0200P

\_\_\_\_\_ or \_\_\_\_\_

**ENGL 260 Preparation for College Reading**  
 4379 LEC HU103 HOOPER J 3.20 3.0 TuTh 1120A-1240P 1

**ENGL 250 Practical Writing**  
 4367 L/L HU103 HOOPER J 4.20 3.0 TuTh 1250P-0220P 1  
 LI120 HOOPER J Tu 1010A-1100A

\_\_\_\_\_ or \_\_\_\_\_

**ENGL 260 Preparation for College Reading**  
 4378 LEC HU103 HOOPER J 3.20 3.0 TuTh 1120A-1240P 1

**ENGL 250 Practical Writing**  
 4368 L/L HU103 HOOPER J 4.20 3.0 TuTh 1250P-0220P 1  
 LI120 HOOPER J Th 1010A-1100A

**Need a Book Loan?**

With an ASB card you can apply for an ASB book loan (up to \$300) at the Financial Aid Office, room SC124.

Buy an ASB card at the Admissions & Records Office, room SC111.



**Footnotes contain valuable information pertaining to your class selection. Footnotes follow class listings.**

Sect. Type Room Instructor Hrs. Units Days Begin-End Footnotes

**ESL 510A Basic ESL I**

**Advisory:** Assessment Recommendation.  
**Transferable:** No

This is an intensive, integrated-skill course for students with little English. Through listening, speaking, reading and writing activities, students learn to use the structures of English with increasing accuracy, while gaining basic life skills. This is a credit/no credit course.

4408	L/L	CJ500	MORAJ	13.60	8.0	DAILY&2.	0910A-1105A
4409	L/L	CJ500	WEXLER L	13.60	8.0	DAILY&2.	1115A-0110P

**ESL 510B Basic ESL II**

**Advisory:** ESL 510A or ESL assessment recommendation.  
**Transferable:** No

This course is a continuation of ESL 510A. This is an intensive, integrated-skill program for students who function in a limited way in English. Through listening, speaking, reading and writing activities, students continue learning to use the structures of English with increasing accuracy, while gaining further basic life skills. This is a credit/no credit course.

4410	L/L	HU101	CISNEROS N	13.60	8.0	DAILY&2.	1115A-0110P
------	-----	-------	------------	-------	-----	----------	-------------

**ESL 521 Beginning ESL Listening/Speaking**

**Advisory:** ESL 510B or ESL Assessment Test Recommendation. Recommended concurrent enrollment in ESL 522 and 523.  
**Transferable:** No

This course develops basic listening and speaking skills, moving from a functional survival context to academic readiness. Activities are directed at providing practice through listening exercises, role-play, pair work, small and large group discussion, interviews, and oral presentations.

4411	L/L	HU101	CAMPBELL K	6.50	4.0	MWF&1	0810A-0920A
------	-----	-------	------------	------	-----	-------	-------------

**ESL 522 Beginning ESL Reading/Vocabulary**

**Advisory:** ESL 510B or 510C or Assessment recommendation. Recommended concurrent enrollment in ESL 521 and 523.  
**Transferable:** No

This course begins the development of reading skills and vocabulary through the application of different reading strategies to a variety of selections on topics of interest to academically-bound students.

4412	L/L	HU101	CISNEROS N	5.50	3.0	TuTh&2.3	0810A-0930A
------	-----	-------	------------	------	-----	----------	-------------

**ESL 523 Beginning ESL Grammar/Writing**

**Advisory:** ESL 510B or ESL Assessment Test recommendation. Recommended concurrent enrollment in ESL 521 and ESL 522.  
**Transferable:** No

This is a beginning grammar/writing course for students with very basic grammar. The focus is on basic grammatical structures, punctuation and sentence skills.

4413	L/L	PB12	SANIDAD M	6.20	5.0	MTuWTh&1	1105A-1210P
6120	L/L	LI100	SHELLEY A SHELLEY A	6.20	5.0	TuTh	0630P-0855P 0900P-0930P

**ESL 531 Intermediate ESL Listening/Speaking I**

**Advisory:** ESL 521 or ESL Assessment Test Recommendation. Recommended concurrent enrollment in ESL 532 and 533.  
**Transferable:** No

In this course, listening and speaking skills are developed through extended listening exercises, open-ended dialogues, pair and group discussions, oral interviews, and oral reports. Units earned in this course do not count toward the associate degree and/or certain certificate requirements.

4414	L/L	HU101	WEXLER L	6.50	4.0	MWF&1	0945A-1055A
------	-----	-------	----------	------	-----	-------	-------------

Sect. Type Room Instructor Hrs. Units Days Begin-End Footnotes

**ESL 532 Intermediate ESL Reading/Vocabulary I**

**Advisory:** ESL 522 or ESL Assessment Recommendation. Recommended concurrent enrollment in ESL 531 and 533.  
**Transferable:** No

This course continues the development of reading skills and vocabulary through the application of different reading strategies to a variety of selections on topics of interest to academically-bound students.

4415	L/L	HU101	CISNEROS N	5.50	3.0	TuTh&2.3	0945A-1105A
------	-----	-------	------------	------	-----	----------	-------------

**ESL 533 Intermediate ESL Grammar/Writing I**

**Prerequisite:** ESL 523 with a grade of C or better or ESL Assessment Test recommendation.  
**Corequisite:** Recommended concurrent enrollment in ESL 531 and ESL 532.  
**Transferable:** No

This course involves the practice and refinement of sentence and paragraph skills, structure and punctuation. Students will learn basic use of the computer as a writing tool. Units earned in this course do not count toward the associate degree and/or certain certificate requirements.

4416	L/L	LI100	LAWN B	6.20	5.0	MTuWTh&1	1225P-0130P
------	-----	-------	--------	------	-----	----------	-------------

**ESL 541 Intermediate ESL Listening/Speaking II**

**Advisory:** ESL 531 or ESL Assessment Recommendation. Recommended concurrent enrollment in ESL 542 and 543.  
**Transferable:** No

This course expands listening and speaking skills through extended listening exercises, open-ended dialogues, pair and group discussions, oral interviews, and oral reports. Students broaden vocabulary while listening to and speaking in both formal and informal, conversational and academic situations.

4417	L/L	HU104	BAAMEUR K	6.50	4.0	MWF&1	1225P-0135P
------	-----	-------	-----------	------	-----	-------	-------------

**ESL 542 Intermediate ESL Reading/Vocabulary II**

**Advisory:** ESL 532 or ESL Assessment Recommendation. Recommended concurrent enrollment in ESL 541 and 543.  
**Transferable:** No

This course begins the expansion of reading skills and vocabulary development through the application of different reading strategies to a variety of selections on topics of interest to academically-bound students including selections from literature.

4418	L/L	HU104	WEXLER L	5.50	3.0	TuTh&2.3	0810A-0930A
------	-----	-------	----------	------	-----	----------	-------------

**ESL 543 Intermediate ESL Grammar/Writing II**

**Prerequisite:** ESL 533 with a grade of C or better or ESL assessment recommendation.  
**Corequisite:** Recommended concurrent enrollment in ESL 541 and ESL 542.  
**Transferable:** No

This course is a continuation of ESL 533. Units earned in this course do not count toward the associate degree and/or certain certificate requirements.

4419	L/L	LI100	LAWN B	6.20	5.0	TuWThF&1	0945A-1050A
------	-----	-------	--------	------	-----	----------	-------------



**ESL 546 Introduction to Computers for ESL Students**

**Advisory:** CSIS 122. Eligible for Gavilan College ESL Program Intermediate.  
**Transferable:** No

Introduction to basic computer hardware functions and terminology; overview of Windows operating environment and word processing for ESL students.

4420	L/L	BU119	CARRILLO L	2.20	1.0	F&1.7	1105A-1200P
------	-----	-------	------------	------	-----	-------	-------------

**ESL 552 Advanced ESL Reading/Vocabulary I**

**Advisory:** ESL 542 or ESL Assessment Recommendation. Recommended concurrent enrollment in ESL 553 and/or ESL 555.  
**Transferable:** No

This course focuses on academic and critical thinking skills needed to increase reading comprehension and efficiency. Emphasis is on analyzing, making inferences, taking notes, supporting opinions, summarizing and expanding vocabulary. Readings are from academic texts and literature.

4421	LEC	LI100	SANIDAD M	4.20	4.0	MWF	0810A-0920A
------	-----	-------	-----------	------	-----	-----	-------------

**Classroom Locations: Refer to "How to Use This Schedule" on page 6.**

Sect. Type Room Instructor Hrs. Units Days Begin-End Footnotes

**ESL 553 Advanced ESL Composition I**

**Prerequisite:** ESL 543 with a grade of C or better or ESL Assessment Test recommendation.  
**Corequisite:** Recommended concurrent enrollment in ESL 552 and ESL 555.  
**Transferable:** No

This course is a composition course for ESL students that develops college composition skills through a review of the parts and elements of the English paragraph and an introduction to the essay form. The course focuses on the development of a paragraph and expands to the writing of multiple paragraphs in an essay. Basic rhetorical patterns and methods of organization are covered using the multiple-draft approach to writing.

4422 L/L HU104 CAMPBELL K 6.20 5.0 MTuWTh&1 1105A-1210P

**ESL 555 Advanced ESL Grammar**

**Prerequisite:** ESL 543 with a grade of C or better or ESL Assessment Test Recommendation.  
**Advisory:** Recommended concurrent enrollment in ESL 553 and ESL 552.  
**Transferable:** No

This course is designed to help students improve their grammar usage so that they will be able to succeed in English composition courses. Students will enhance their writing skills by practicing with previously encountered basic structures as well as newly acquired more sophisticated ones.

4423 L/L HU104 CAMPBELL K 6.20 5.0 TuWThF&1 0945A-1050A

**ESL 562 Advanced ESL Reading/Vocabulary II**

**Advisory:** ESL 552 or ESL Assessment recommendation. Recommended concurrent enrollment in ESL 563.

**Transferable:** No

This course prepares ESL students for mainstream college classes by reviewing a variety of reading skills, strategies, and topics from different academic disciplines. Students expand their academic vocabulary and read short stories or a novel for literary appreciation.

4424 LEC LI100 LAWN B 4.50 4.0 MWF 1105A-1215P

**ESL 563 Advanced ESL Composition II**

**Prerequisite:** ESL 553 with a grade of "C" or better or ESL Assessment Test recommendation.  
**Advisory:** Recommended concurrent enrollment in ESL 561.

**Transferable:** No

This course which is designed for ESL students, refines and further expands college composition skills through the writing of essays using the multiple-draft approach to writing. The course focuses on the structuring and development of an essay with the use of personal examples and/or outside sources. Students write in response to a variety of prompts and viewpoints on issues using different rhetorical patterns, and they are introduced to writing tasks used in academic disciplines other than English.

4425 L/L PB12 BAAMEUR K 6.40 5.0 TuWThF&1 0945A-1050A

**NEW ESL 584 Culture Through Film**

**Advisory:** ESL 541 or ESL Assessment recommendation.  
**Transferable:** No

This course is designed to practice listening and speaking skills through the use of selected films. The course highlights different intercultural issues and aspects of American culture, and students enhance their listening and speaking skills by means of authentic discourse. Because film provides a real sample of speech in a multi-dimensional experience, ESL learners can experience the language in a more complete manner while analyzing cultural issues. This is a credit/no credit course.

4426 LEC LI100 MAXWELL K 3.20 3.0 TuTh 0810A-0930A

**Film: see ENGL 2C, HUM 3, 4, 10**

**Foreign Language: See French (FRNH), Japanese (JPN), Spanish (SPAN)**



**STAFF**

**Michael Giovannini**

Originally from Massachusetts, I attended Central Missouri State University to fly helicopters and pursue a Bachelor's Degree in Aviation Technology. Before I could start my flight training the school sold the helicopters. I had always been involved with campus activities and assisting students so, upon completing my Aviation Degree, I began my Master's Degree in College Student Personnel Administration. After graduating I worked at the university as an Admissions Counselor for three years, traveling throughout the state and talking with high school students about attending the university. Three years later I joined the Army to pursue a life-goal of flying helicopters. Upon completing my service obligation, (including 13 months in Iraq), I transitioned out of the service and am back working in higher education with college students.

I consider myself fortunate to have found two careers that I thoroughly enjoyed and really benefit me as a Career/Transfer Specialist. Through my experiences in higher education, traveling half-way across the country to go to school, and being in the military, I believe that I have a broad knowledge-base to assist students.

The resources available in the Career/Transfer Center (SC 102) are available to all students and the community. Whether you are unsure of what direction you are headed, need information about a particular degree, or are looking for a part-time job, the Career/Transfer Center is available to help you "Set Your Direction".

**OVERVIEW OF ESL COURSES**

L/S = Listening/Speaking  
 R = Reading  
 GW = Grammar/Writing

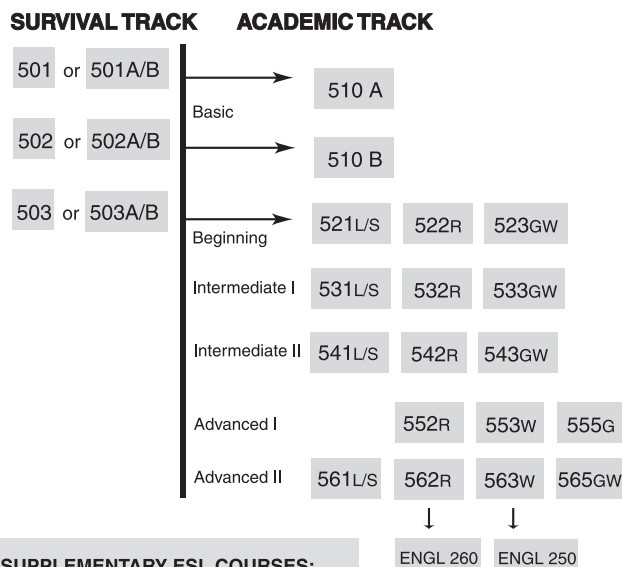

**SUPPLEMENTARY ESL COURSES:**  
**ESL 546** Introduction to Computers/ESL  
**ESL 556** Information Competency for ESL  
**ESL 581** Pronunciation I  
**ESL 582** Pronunciation II  
**ESL 584** Culture through Film



Sect. Type Room Instructor Hrs. Units Days Begin-End Footnotes

**FRENCH**

**FRNH 1A Elementary French**

**Transferable:** CSU; UC; CSU-GE: C2; IGETC: 6A; GAV-GE: C2

French 1A is a multi-skilled beginning level class with emphasis on understanding and speaking French. Students are introduced to the cultures and customs of various French-speaking countries.

4428 L/L SS216 SANIDAD M 7.80 5.0 MTuWTh&2.3 1250P-0155P

**GEOGRAPHY**

**See also CSIS 61 (Geographic Info. Systems)**

**GEOG 1 Physical Geography**

**Advisory:** Eligible for English 250 and English 260.

**Transferable:** CSU; UC; CSU-GE: B1, B3; IGETC: 5A; GAV-GE: B1, B3; CAN: GEOG 2

An introductory study of the basic physical elements of geography including climate, land forms, soils, water, and natural vegetation. The laboratory will include the tools and methods of geographers.

4430 L/L HOL1 WILLAHAN D 5.40 3.0 MW 0945A-1210P  
Above class meets at the Hollister Briggs site

**GEOLOGY**

**GEOL 1 Introduction to Geology**

**Advisory:** Eligible for English 250 and English 260.

**Transferable:** CSU; UC; CSU-GE: B1, B3; IGETC: 5A; GAV-GE: B1, B3; CAN: GEOL 2

A study of the earth and the physical properties which modify the earth; minerals, rocks, geologic structures and processes.

4431 L/L PB12 STAFF 6.60 4.0 MTuWTh 0810A-0930A 1  
4432 L/L PB12 WILLAHAN D 6.60 4.0 MW 1250P-0355P 1

**Government: see Political Science**  
**Graphic Arts: see Art, CSIS, Digital Media**

**GUIDANCE**

**GUID 1 Self-Assessment and Career Development**

**Advisory:** Eligible for English 250 and English 260.

**Transferable:** CSU; CSU-GE: E2; GAV-GE: E2

This course is designed to assist the student in learning more about personal values, personality, interests, exploration of career choice, and occupational opportunities through the use of various personal assessment instruments. The delivery options for this course also include online and self-paced formats. This course is also listed as PSYC 5.

4434 LEC HOL2 LOPEZ A 2.30 2.0 W 0230P-0435P 25 89  
Above class meets at the Hollister Briggs site  
4435 LEC PB13 GODLEY J 2.30 2.0 Th 0230P-0435P 25 89  
4436 ONLINE SHARBONEAU 2.30 2.0 DHR 0000-0000 25 38 89

 This online class will be delivered entirely over the internet. After enrolling, start the class by going to <http://www.gavilan.edu/disted/>, click on your class link and email the instructor at [rsharboneau@gavilan.edu](mailto:rsharboneau@gavilan.edu). Students who have not begun the class or contacted the instructor by 5 pm on Feb. 4 will be dropped from the class.

**PUENTE LEARNING COMMUNITY SECTION:**

4433 LEC PB5 MARQUEZ C 2.30 2.0 M 1120A-0125P 39 50 89  
Additional meeting required on Wednesdays from 11:20 am -12:10 pm in PB7.

Sect. Type Room Instructor Hrs. Units Days Begin-End Footnotes

**GUID 22 Field Work and Service**

**Required:** Learning contracts must be filled out and signed by the student and the supervising instructor.

**Transferable:** CSU

Supervised field work within the college and with local agencies. Students serve in useful group activities in leadership roles prescribed for them by faculty or community agencies. A maximum of six units may be completed. This is a credit/no credit course.

4438 FEX LI117 EASTMAN B 3.40 1.0 Day/Time - See instructor 22 73

**GUID 28 Tutoring Techniques**

**Advisory:** English 250.

**Transferable:** CSU

This course is designed to train students in effective tutoring skills, introduction to how people learn, teaching to modalities, and techniques of working with student anxiety. This course has the option of a letter grade or credit/no credit.

4439 L/L SS111 RODERICK D 3.00 1.0 F 1100A-1240P 11 19 37  
LI116 RODERICK D S 0930A-0130P  
02/08/08 - 04/04/08 This class meets seven Fridays, February 8 – April 4, 2008 (no class on Feb. 15 due to President's Day instructional break). There is only ONE Saturday meeting (February 23, 2008) that will meet in LI 116.

**GUID 29 Tutoring Lab**

**Advisory:** Completion of, or concurrent enrollment in Guidance 28.

**Transferable:** CSU

This course will allow students to gain valuable experience in the field of teaching. Students will practice the skills they have learned in Guidance 28. Guidance 29 may be repeated for a maximum of 2.0 units per semester and a maximum course total of 8.0 units. This is a credit/no credit course.

4440 LAB LI116 RODERICK D 3.40 1.0 DHR 0000-0000 31  
4441 LAB LI116 RODERICK D 6.80 2.0 DHR 0000-0000 31

**GUID 250 Supervised Tutoring**

**Transferable:** No

Laboratory class emphasizing college learning skills, appropriate study techniques, and learning assistance utilizing one-on-one or small group tutorial.

Laboratory class emphasizing college learning skills, appropriate study techniques, and learning assistance utilizing one-on-one and/or small group tutorial. GUID 250 is a noncredit class and will not appear on a student's transcript.

4443 LI116 STAFF 0.0 DHR 0000-0000  
4444 LI168 STAFF 0.0 DHR 0000-0000  
4445 LI116 STAFF 0.0 DHR 0000-0000  
4446 LI120 STAFF 0.0 DHR 0000-0000  
4447 LI168 STAFF 0.0 DHR 0000-0000  
4448 HOB104 BEDELL K 0.0 DHR 0000-0000  
4449 LI126 BEEDE R 0.0 DHR 0000-0000  
4450 PH101 STAFF 0.0 DHR 0000-0000  
4451 HOB104 BEDELL K 0.0 DHR 0000-0000

**GUID 530 Job Readiness**

**Transferable:** No

This course is designed to provide a comprehensive, well-organized approach to assist individuals with the identification of occupational choices and the development of job readiness skills necessary to obtain and maintain employment in a competitive or supported work setting. May be repeated twice for credit. This course has the option of a letter grade or credit/no credit.

4452 LAB BU117 FRANKLIN L 3.40 3.0 TuTh 0945A-1105A 75

Sect. Type Room Instructor Hrs. Units Days Begin-End Footnotes

**GUID 557 Learning Skills Assessment**

Transferable: No

This course provides an assessment of the students' cognitive/perceptual abilities and basic skills academic achievement. The assessment results are used to determine the students' eligibility for Learning Disabilities Services, to develop individual educational plans, and/or to improve the students' understanding of their own learning strengths and weaknesses. The assessment is conducted on a one-to-one basis by appointment. Units earned in this course do not count toward the associate degree and/or certificate requirements. This is a credit/no credit course.

4453 LAB LI117 FRIEDMAN M 1.00 .5 Day/Time - See instructor 2 31

**GUID 558 Learning Skills Laboratory**

Advisory: Completion of Guidance 557 or demonstrated academic deficit.

Transferable: No

The Learning Skills Laboratory is designed to assist students who are eligible to receive Learning Disabilities Services and/or have demonstrated academic deficits. The course content is individualized and based on Student Educational Contracts which are developed for each student. Students receive supplemental instruction, academic support, and learning strategy suggestions appropriate for their individual cognitive, perceptual, and academic strengths and weaknesses. Units earned do not count towards the associate degree and/or certificate requirements. This is a credit/no credit course.

4454 LAB LI116 FRIEDMAN M 3.40 1.0 Day/Time - See instructor 12 31

4455 LAB LI116 FRIEDMAN M 6.80 2.0 Day/Time - See instructor 12 31

4456 LAB LI116 FRIEDMAN M 1.70 .5 Day/Time - See instructor 12 31

**GUID 561 Writing Skills**

Advisory: Completion of Guidance 557 or demonstrated deficit in written language achievement.

Transferable: No

This course is designed to teach basic writing skills to students who have demonstrated difficulty mastering written language and who are eligible to receive Learning Disability Services. Material is presented in a concrete, multi-sensory manner, and the class includes opportunity for immediate practice, repetition, and review. The course content includes grammar, sentence structure, and punctuation. Units earned do not count toward the associate degree and/or certificate requirements. This course has the option of a letter grade or credit/no credit.

4457 LAB BU117 MARINGER J 2.20 1.0 TuTh 1120A-1220P

**GUID 562 Directed Study Lab in Arithmetic**

Corequisite: Concurrent enrollment in MATH 400.

Advisory: Completion of GUID 557 and/or a demonstrated deficit in arithmetic.

Transferable: No

This course is designed for students who have demonstrated difficulty in mastering arithmetic and who are eligible to receive Learning Disability Services. Course content parallels Mathematics 400. Material is presented in a concrete, multi-sensory manner, and the lab allows opportunity for immediate practice, questions, repetition, and review. Units earned do not count toward the associate degree and/or certificate requirements. This is a credit/no credit course.

4458 LAB SS216 BURGMAN,L 3.40 1.0 TuTh 1120A-1240P 12

**GUID 563B Directed Study Lab in Algebra**

Corequisite: Concurrent enrollment in MATH 205B is required.

Advisory: Completion of GUID 557 or demonstrated deficit in mathematics.

Transferable: No

This course is designed for students who have demonstrated difficulty mastering elementary algebra and who are eligible to receive Learning Disability Services. Course content parallels Mathematics 205B. Material is presented in a concrete, multi-sensory manner, and the lab allows opportunity for immediate practice, questions, repetition, and review. This is a credit/no credit course.

4459 LAB PB16 FRIEDMAN M 4.50 1.0 MW 1120A-1240P 12

*C'est Chic!  
Learn French!*



**FRNH 1A**  
Elementary French

SECT. 4428  
Monday-Thursday  
12:50-1:55  
SS216  
Instructor: Mary Ann Sanidad

*This course satisfies the general education Humanities (Area C-2) requirement under the AA/AS Degree and the CSU-GE Breath pattern, and the first half of the language requirement for UC.*

STUDENT Profile



**Sonia Richards**

Gavilan is not only a place for learning. It is also an institution known for new beginnings.

On any given day you may see Sonia Richards zooming around campus on her electric scooter. With a smile on her face, she knows Gavilan is the place for her new beginning. When Sonia suffered a stroke three years ago, she thought, "What am I going to do?" As soon as she was well enough, Sonia's Department of Rehabilitation counselor suggested she enroll at Gavilan College. Sonia has now become a member of the Gavilan College Disability Resource Center family, where she enjoys taking adaptive swimming, adaptive computer courses, & regaining her reading and writing skills in English. "Little by little", she says, she continues to push herself to reaching new goals. She she likes Gavilan College because it is a 'stimulating' place to learn. In 2006, Sonia's hard work and positive attitude earned her the Patsy Johnson Scholarship.



The Puente Project is a two-semester program that combines three components: writing, counseling and mentoring to support students to transfer to four-year universities and colleges. The Guidance 6 course focuses on life skills for higher education and transfer. The English 250 course focuses on Mexican American/Latino literature. The program also includes a student leadership conference, university visits and mentor/student socials. The program is open to all eligible students. For more information, call Celia Marquez, Puente Co-Coordinator at 408-848-4807.

**Required:** Complete a program application with the Puente Counselor prior to registration.

**ENGL 1A Composition**

4321 LEC SS203 SANDLER S 3.20 3.0 TuTh 1120A-1240P 1 82

**GUID 1 Self Assessment and Career Development**

4433 LEC PB5 MARQUEZ C 2.30 2.0 M 1120A-0125P 39 50 89  
Additional meeting required on Wednesdays from 11:20 am -12:10 pm in PB7.

Sect. Type Room Instructor Hrs. Units Days Begin-End Footnotes

**GUID 564 Directed Study Lab in Pre-Algebra**

**Corequisite:** Concurrent enrollment in MATH 402.  
**Advisory:** Completion of Guidance 557 and/or a demonstrated deficit in Mathematics.  
**Transferable:** No

This course is designed for students who are eligible to receive Learning Disability Services and/or who have demonstrated difficulty in mastering pre-algebra. The course content parallels Mathematics 402. The material is presented in a concrete, multi-sensory manner, and the lab environment allows opportunity for immediate practice questions, repetition and review. Units earned do not count towards the associate degree and/or certificate requirements. This is a credit/no credit course.

4460 L/L BU117 BURGMAN,L 3.40 1.0 MW 1120A-1240P 12

**HEALTH EDUCATION**

**HE 1 Health Education**

**Advisory:** Eligible for English 250 and English 260.  
**Transferable:** CSU; UC; CSU-GE: E2; GAV-GE: E2

This course focuses on attaining individual awareness, critical-thinking skills and self-responsibility relating to personal health. The interaction of individual physical, psychological, social, emotional, spiritual and environmental factors in determining health status is developed through integration of major concepts. This course has the option of a letter grade or credit/no credit.

4461 LEC PB16 DODDS 3.20 3.0 TuTh 0945A-1105A

4462 ONLINE QUATRE S 3.30 3.0 DHR 0000-0000 38

 This online class will be delivered entirely over the internet. After enrolling, start the class by going to <http://www.gavilan.edu/disted/>, click on your class link and email the instructor at [squatre@gavilan.edu](mailto:squatre@gavilan.edu). Students who have not begun the class or contacted the instructor by 5 pm on Feb. 4 will be dropped from the class.

**HE 2 Human Sexuality**

**Advisory:** Eligible for English 250 and English 260  
**Transferable:** CSU; UC; CSU-GE: E2; GAV-GE: E2

Assists students in gaining increased knowledge, appreciation, and respect for their own sexuality, as well as others. Approved by the Board of Registered Nursing for 54 hours of continuing education credit (Provider #00892).

4463 LEC PB16 LOGAN C 3.20 3.0 MW 0945A-1105A

4464 ONLINE QUATRE S 3.30 3.0 DHR 0000-0000 38

 This online class will be delivered entirely over the internet. After enrolling, start the class by going to <http://www.gavilan.edu/disted/>, click on your class link and email the instructor at [squatre@gavilan.edu](mailto:squatre@gavilan.edu). Students who have not begun the class or contacted the instructor by 5 pm on Feb. 4 will be dropped from the class.

**HISTORY**

**HIST 1 United States History through Reconstruction**

**Advisory:** Eligible for English 250 and English 260.  
**Transferable:** CSU; UC; CSU-GE: C2, D6; IGETC: 3B, 4F, 7B; GAV-GE: C2, D2; CAN: HIST 8, HIST SEQ. B

History of the United States from the time before European contact with the Americas through Reconstruction. Emphasis will be placed on distinctive patterns of political, economic, social, intellectual, and geographic developments within their global context. At the conclusion of the course, the student should understand major themes in the history of the United States, and be able to explain various ways in which ideas about federal vs. state power, ethnicity, class, and gender divisions have influenced the nation's development. This course has the option of a letter grade or credit/no credit.

4465 LEC MHG4 MOSHER C 3.20 3.0 MW 0810A-0930A

Above class meets at Morgan Hill Community site

4466 LEC SS210 KIER D 3.20 3.0 TuTh 0945A-1105A

4467 LEC SS214 LUNA E 3.20 3.0 MW 1250P-0210P

4468 LEC SS214 LUNA E 3.20 3.0 TuTh 0230P-0350P

6126 LEC MHG4 MOSHER C 3.30 3.0 Tu 0600P-0905P

Above class meets at Morgan Hill Community site

Sect. Type Room Instructor Hrs. Units Days Begin-End Footnotes

**HIST 2 United States History Reconstruction to the Present**

**Advisory:** Eligible for English 250 and English 260.  
**Transferable:** CSU; UC; CSU-GE: C2, D6; IGETC: 3B, 4F, 7B; GAV-GE: C2, D2; CAN: HIST 10, HIST SEQ. B

History of the United States from Reconstruction to the present. Emphasis will be placed on distinctive patterns of political, economic, social, intellectual, and geographic developments within their global context. At the conclusion of the course, the student should understand major themes in the history of the United States, and be able to explain various ways in which ideas about federal vs. state power, ethnicity, class, and gender divisions have influenced the nation's development. This course has the option of a letter grade or credit/no credit.

4469 LEC PB5 GUARDINO L 3.30 3.0 F 0810A-1115A

4470 LEC MHG12 MOSHER C 3.20 3.0 MW 0945A-1105A

Above class meets at Morgan Hill Community site

4471 LEC SS210 CRUICKSHANK 3.20 3.0 MW 1120A-1240P

4472 LEC SS214 HALPER L 3.20 3.0 TuTh 1120A-1240P

4473 LEC SS210 HALPER L 3.20 3.0 TuTh 1250P-0210P

6127 LEC SS214 HALPER L 3.30 3.0 Tu 0600P-0905P

6128 LEC HOL2 LUNA E 3.30 3.0 W 0600P-0905P

Above class meets at the Hollister Briggs site

**HIST 4A History of World Societies, Before 1500**

**Advisory:** English 250 and English 260.  
**Transferable:** CSU; UC; CSU-GE: C2, D6; IGETC: 3B, 4F; GAV-GE: C2, D2

A study of major elements in the development of and interactions between world societies, from the first organization of community to the dawn of the Renaissance. Students will comparatively analyze social, cultural, geographic, economic, demographic, technological, environmental, and political developments that moved humans from nomadic to agri-technological and urban lives. This course has the option of a letter grade or credit/no credit.

4474 LEC SS205 HALPER L 3.20 3.0 MW 1250P-0210P

**HIST 6 Women's Lives in Recent United States History**

**Advisory:** English 250  
**Transferable:** CSU; UC; CSU-GE: C2, D4, D6; IGETC: 3B, 4F; GAV-GE: C2,

The class examines the construction of womanhood in the US during the twentieth century. The class explores the effects of gender, ethnicity, class, and sexual orientation upon women's experiences. Students will study the contributions of various individual women and groups of women in creating the modern United States, and will analyze social, political, economic, and cultural forces affecting women to both join and resist movements for social change. Students will also learn to apply contemporary feminist theory to traditional historical approaches.

6129 LEC SS205 GUARDINO L 3.30 3.0 M 0600P-0905P

**HIST 7B History of Western Civilization**

**Advisory:** Eligible for English 250 and English 260.  
**Transferable:** CSU; UC; CSU-GE: C2; IGETC: 3B; GAV-GE: C2; CAN: HIST 4, HIST SEQ. A

A study of major elements in western heritage from Renaissance Europe to the present. Emphasis is on ideas, attitudes and institutions basic to western civilization of enduring interest.

4475 LEC SS110 KIER D 3.20 3.0 TuTh 0810A-0930A

**HIST 12 Cultural History of the Mexican American**

**Advisory:** Eligible for English 250 and English 260.  
**Transferable:** CSU; UC; CSU-GE: C2, D3, D6; IGETC: 4F, 3B; GAV-GE: D2,

The Mexican American experience as influenced by society in the United States. Emphasis will be on the historical and contemporary contributions made by the Indian, Spanish, Mexican, and Mexican American. Emphasis will also be on the social, economic, and political milieu of the Mexican American within the context of the American society. This course has the option of a letter grade or credit/no credit.

4476 LEC SS210 LUNA E 3.20 3.0 TuTh 1120A-1240P

Sect. Type Room Instructor Hrs. Units Days Begin-End Footnotes

**HIST 21 Ancient Americas: A History through Art**

Advisory: Eligible for English 250.

Transferable: CSU; UC; CSU-GE: C1, C2; IGETC: 3A; GAV-GE: C2, F

A critical survey of history through the arts of pre-Columbian natives of North, Central and South America. The course will cover major societies and events from the appearance of major civilizations through the initial colonization efforts of European nations. Due to the distinct history of the Americas, this course uses the arts - architecture, sculpture, ceramics and painting, among others - of ancient societies as a primary source material. This course has the option of a letter grade or credit/no credit. This course is also listed as ART 21.

6130	LEC	SS210	LUNA E	3.30	3.0	M	0600P-0905P
------	-----	-------	--------	------	-----	---	-------------

**HUMANITIES**

**HUM 4 Introduction to American Cinema**

Advisory: English 440

Transferable: CSU; UC; CSU-GE: C2; IGETC: 3B; GAV-GE: C2

This introductory course in film studies is a survey of the American film industry as an art form, as an industry, and as a system of representation and communication. The course explores how Hollywood films work technically, aesthetically, and culturally to reinforce and challenge America's national self-image.

4477	ONLINE	RICHARDS G	3.30	3.0	DHR	0000-0000	38
------	--------	------------	------	-----	-----	-----------	----

This online class will be delivered entirely over the internet. After enrolling, start the class by going to <http://www.gavilan.edu/disted/>, click on your class link and email the instructor at [grichards@gavilan.edu](mailto:grichards@gavilan.edu). Students who have not begun the class or contacted the instructor by 5 pm on Feb. 4 will be dropped from the class.

**HUM 6 Foreign Cinema**

Transferable: CSU; UC; CSU-GE: C1; IGETC: 3A; GAV-GE: C1

This class is a survey of significant developments in narrative film outside Hollywood. Differing international contexts, theoretical movements, technological innovations, and major directors are studied. The class offers a global, historical overview of narrative content and structure, production techniques, audience, and distribution. Students screen a variety of rare and popular films, focusing on the artistic, historical, social, and cultural contexts of film production. Students develop critical thinking skills and address issues of popular culture, including race, class, gender, and equity.

4478	LEC	PLY	RICHARDS G	3.30	3.0	W	0200P-0505P
------	-----	-----	------------	------	-----	---	-------------

Above class meets at the Morgan Hill Playhouse. See page 6 for a list of off-campus locations.

**HUM 10 Approaches to Contemporary Film**

Advisory: Eligibility for English 250 and 260.

Transferable: CSU; UC; CSU-GE: C1, C2; IGETC: 3B; GAV-GE: C1, C2

Approaches to Contemporary Film examines theories of film criticism as they apply to films from 1960 to the present. Students learn technical, visual, classical, historical, cultural, ideological, and aesthetic approaches to film and sample from a representative list of foreign and domestic movies. Special emphasis is given to new voices from non-American sources and to emerging voices in American cinema.

4479	LEC	SS214	RICHARDS G	3.30	3.0	MW	1120A-1240P
4480	LEC	SS214	RICHARDS G	3.30	3.0	TuTh	1250P-0210P

**HUM 23 Independent Study**

Required: The study outline prepared by the student and the instructor must be filed with the department and the dean.

Transferable: CSU

Designed to afford selected students specialized opportunities for exploring areas at the independent study level. The courses may involve extensive library work, research in the community, or special projects. May be repeated until six units of credit are accrued. This course has the option of a letter grade or credit/no credit.

4481	IND	HU111	RICHARDS G	3.30	1.0	DHR	0000-0000	22
4482	IND	HU111	RICHARDS G	6.80	2.0	DHR	0000-0000	22

Footnotes contain valuable information pertaining to your class selection. Footnotes follow class listings.

View films from categories such as:  
Musical  
War  
Film Noir  
Western  
Comedy  
Adventure  
Fantasy/Horror  
Silent  
Suspense & Intregue

Now offered Online

Sect. Type Room Instructor Hrs. Units Days Begin-End Footnotes

**INDUSTRIAL TECHNOLOGY**

**IT 115 Industrial Safety**

Advisory: Eligible for English 250 and English 260.

Transferable: CSU

This course is an introduction to the construction industry. It will cover the basic skill sets required to earn an entry-level position in various trades in construction. Students will learn basic math, vocabulary, blue print reading and safety skills along with the soft skills required to gain employment. This course has the option of a letter grade or credit/no credit.

6132	LEC	SS205	WRIGHT D	3.30	3.0	W	0600P-0905P	96
------	-----	-------	----------	------	-----	---	-------------	----

**Information Science: see CSIS**

**JAPANESE**

**JPN 1A Elementary Japanese**

Transferable: CSU; UC; CSU-GE: C2; GAV-GE: C2

Beginning course with emphasis on understanding and speaking Japanese; introduction to reading and writing Japanese. This course will also introduce students to Japanese culture and institutions. This course has the option of a letter grade or credit/no credit.

4561	L/L	SS110	SAKAI T	7.90	5.0	MW&2.3	1250P-0315P
------	-----	-------	---------	------	-----	--------	-------------

**JPN 23 Independent Study**

Required: The study outline prepared by the student and the instructor must be filed with the department and the dean.

Transferable: No

Designed to afford selected students specialized opportunities for exploring areas at the independent study level. The course may involve extensive library work, research in the community, or special projects. May be repeated until six units of credit are accrued. This course has the option of a letter grade or credit/no credit.

4562	IND	SS110	SAKAI T	6.80	2.0	DHR	0000-0000
------	-----	-------	---------	------	-----	-----	-----------

Sect. Type Room Instructor Hrs. Units Days Begin-End Footnotes

**JOURNALISM****JOUR 10 Mass Media and Society****Advisory:** English 250, English 260.**Transferable:** CSU; UC; CSU-GE: C2, D0; IGETC: 4J; GAV-GE: C2, D2; CAN: JOUR 4

This course helps students understand the 20th century revolution in mass media by focusing on the history, economics and social impact of the newspaper, book publishing, magazine, film, television, public relations, advertising and music industries. Students will study audience, propaganda and mass communication theory; and discuss new technology, ethnic media in the United States, ethical issues and attempts to regulate or control the media. Honors students will complete more in-depth analysis of media issues and will finish a media-related research project. This course is also listed as SOC 10. This course has the option of a letter grade or credit/no credit.

4538 LEC AR103 GUERRAZZI D 3.20 3.0 MW 0810A-0930A

**JOUR 18A Working on the Newspaper****Advisory:** Eligible for English 1A. Typing ability.**Transferable:** CSU; GAV-GE: C1

Students interview, write, photograph and do computer assisted design and graphics for the college newspaper, The Gavilan Press. In doing this, they provide the community with an important first amendment forum, learn and educate about the first amendment rights and responsibilities, and acquire journalistic skills, ethics, and habits.

4539 LAB HU106 GUERRAZZI D 2.30 2.0 MW 1120A-1225P 1

4540 LAB HU106 GUERRAZZI D 5.60 3.0 MW 1120A-0145P 1

4541 LAB HU106 GUERRAZZI D 8.90 4.0 MW&amp;3.3 1120A-0145P 1

4542 LAB HU106 GUERRAZZI D 12.00 5.0 MW&amp;6.4 1120A-0145P 1

**JOUR 18B Working on the Newspaper****Advisory:** Journalism 18A.**Transferable:** CSU; GAV-GE: C1

Students interview, write, photograph and do computer assisted design and graphics for the college newspaper, The Gavilan Press. In doing this, they provide the community with an important first amendment forum, learn and educate about the first amendment rights and responsibilities and acquire journalistic skills, ethics and habits.

4543 LAB HU106 GUERRAZZI D 2.30 2.0 MW 1120A-1225P 1

4544 LAB HU106 GUERRAZZI D 5.60 3.0 MW 1120A-0145P 1

4545 LAB HU106 GUERRAZZI D 8.90 4.0 MW&amp;3.3 1120A-0145P 1

4546 LAB HU106 GUERRAZZI D 12.00 5.0 MW&amp;6.4 1120A-0145P 1

**JOUR 18C Working on the Newspaper****Advisory:** Journalism 18B.**Transferable:** CSU; GAV-GE: C1

Students interview, write, photograph and do computer assisted design and graphics for the college newspaper, The Gavilan Press. In doing this, they provide the community with an important first amendment forum, learn and educate about the first amendment rights and responsibilities and acquire journalistic skills, ethics and habits.

4547 LAB HU106 GUERRAZZI D 2.30 2.0 MW 1120A-1225P 1

4548 LAB HU106 GUERRAZZI D 5.60 3.0 MW 1120A-0145P 1

4549 LAB HU106 GUERRAZZI D 8.90 4.0 MW&amp;3.3 1120A-0145P 1

4550 LAB HU106 GUERRAZZI D 12.00 5.0 MW&amp;6.4 1120A-0145P 1

Sect. Type Room Instructor Hrs. Units Days Begin-End Footnotes

**JOUR 18D Working on the Newspaper****Advisory:** Journalism 18C.**Transferable:** CSU; GAV-GE: C1

Students interview, write, photograph and do computer assisted design and graphics for the college newspaper, The Gavilan Press. In doing this, they provide the community with an important first amendment forum, learn and educate about the first amendment rights and responsibilities and acquire journalistic skills, ethics and habits.

4551 LAB HU106 GUERRAZZI D 2.30 2.0 MW 1120A-1225P 1

4552 LAB HU106 GUERRAZZI D 5.60 3.0 MW 1120A-0145P 1

4553 LAB HU106 GUERRAZZI D 8.90 4.0 MW&amp;3.3 1120A-0145P 1

4554 LAB HU106 GUERRAZZI D 12.00 5.0 MW&amp;6.4 1120A-0145P 1

**JOUR 22 Field Work and Service****Required:** Learning contracts must be filled out and signed by the student and the supervising instructor.**Transferable:** CSU; GAV-GE: C1

Supervised field work within the college and with local agencies. Students serve in useful group activities in leadership roles prescribed for them by faculty or community agencies. A maximum of six units may be completed. This is a credit/no credit course.

4555 IND HU107 GUERRAZZI D 3.30 1.0 TBA 0000-0000 21

**JOUR 23 Independent Study****Required:** The study outline prepared by the student and the instructor must be filed with the department and the dean.**Transferable:** CSU; GAV-GE: C1

Designed to afford selected students specialized opportunities for exploring areas at the independent study level. The courses may involve extensive library work, research in the community, or special projects. May be repeated until six units of credit are accrued. This course has the option of a letter grade or credit/no credit.

4556 IND HU106 GUERRAZZI D 6.40 2.0 DHR 0000-0000 22

**JOUR 190 Occupational Work Experience/Journalism****Required:** Enrollment in a minimum of seven (7) units, including Cooperative Work Experience, during regular semesters; enrollment in at least one other class in summer session.**Transferable:** CSU

The application of learned theory, knowledge, and skills to a practical job setting related to the student's educational/occupational goal. Employment must be directly related to the student's college educational/occupational goal. Periodic interviews of the students and employers or their representatives will be required. Each student shall be assisted in the development of individualized performance objectives, toward which the learning experience shall be directed.

4557 WEX BU125 KERR L 5.30 1.0 DHR 0000-0000

4558 WEX BU125 KERR L 10.60 2.0 DHR 0000-0000

4559 WEX BU125 KERR L 15.90 3.0 DHR 0000-0000

4560 WEX BU125 KERR L 21.20 4.0 DHR 0000-0000

**Your educational plan:**

You are expected to take the responsibility for scheduling an appointment with a counselor, preferably at least once a semester. The purpose of this appointment is to develop, review and update your educational plan to ensure that you are taking the appropriate courses to meet your educational goal.

**Classroom Locations: Refer to "How to Use This Schedule" on page 6.**

Sect. Type Room Instructor Hrs. Units Days Begin-End Footnotes

JPA Fire Technology and JPA Law Enforcement



# Careers in

Law Enforcement • Fire Technology

Probation Officer • Dispatcher

Corrections Officer • Juvenile Hall Counselor

Gavilan College is a member of the South Bay Regional Public Safety Training consortium. This consortium is funded by all colleges regionally to provide vocational specific training which may require special facilities, special training conditions or is presented outside of the schedules of regular college classes. For more information call 408-270-6458.

**Law Enforcement: see also Administration of Justice**

## LIBRARY

### LIB 3 Research Skills

**Advisory:** Eligible for English 250 and 260.  
**Transferable:** CSU

Research and evaluation skills using the Internet and other electronic resources, as well as traditional printed materials. Also listed as CSIS 3. This course has the option of a letter grade or credit/no credit. May be repeated once for credit. Also listed as CSIS 3.

4563 ONLINE MEADER S 4.60 2.0 DHR 0000-0000 11 25 38  
01/02/08 - 02/27/08 This online class will be delivered entirely over the internet. After enrolling, start the class by going to <http://www.gavilan.edu/disted/>, click on your class link and email the instructor at [smeader@gavilan.edu](mailto:smeader@gavilan.edu). Students who have not begun the class or contacted the instructor by 5 pm on Jan. 7 will be dropped from the class.



### LIB 6 Web Page Authoring I

**Advisory:** CSIS 1 or CSIS 2 or CSIS/LIB 3 advised.  
**Transferable:** CSU; GAV-GE: E2

An introduction to using Hypertext Mark-Up Language (HTML) and Extensible HTML (XHTML) to create web pages which can be uploaded and displayed on the World Wide Web. Students will use HTML/XHTML to create web pages with text in various sizes and colors, links to other sites, background color or patterns, graphics, tables, and mailto links. Principles of design and color as they apply to screen presentations will be included. This course has the option of a letter grade or credit/no credit. May be repeated three times for credit. Also listed as CSIS 6 and DM 6.

4567 ONLINE VANTASSEL D 6.00 2.0 DHR 0000-0000 11 25 38  
01/07/08 - 02/14/08 This online class will be delivered entirely over the internet. After enrolling, start the class by going to <http://www.gavilan.edu/disted/>, click on your class link and email the instructor at [dvantassel@gavilan.edu](mailto:dvantassel@gavilan.edu). Students who have not begun the class or contacted the instructor by 5 pm on January 9 will be dropped from the class.



4564 LEC LI126 VANTASSEL D 4.60 2.0 MW 0945A-1135A  
01/30/08 - 03/19/08

4565 ONLINE HOWELL J 4.60 2.0 DHR 0000-0000 11 25 38  
01/30/08 - 04/01/08 This online class will be delivered entirely over the internet. After enrolling, start the class by going to <http://www.gavilan.edu/disted/>, click on your class link and email the instructor at [jhowell@gavilan.edu](mailto:jhowell@gavilan.edu). Students who have not begun the class or contacted the instructor by 5 pm on February 4 will be dropped from the class.



4566 ONLINE VENABLE E 4.60 2.0 DHR 0000-0000 11 25 38  
03/31/08 - 05/21/08 This online class will be delivered entirely over the internet. After enrolling, start the class by going to <http://www.gavilan.edu/disted/>, click on your class link and email the instructor at [evenable@gavilan.edu](mailto:evenable@gavilan.edu). Students who have not begun the class or contacted the instructor by 5 pm on April 2 will be dropped from the class.



**Footnotes contain valuable information pertaining to your class selection. Footnotes follow class listings.**



Take this class!  
Get a job!

Prepare for a career  
in the building trades.

## IT 115 Industrial Safety

Wednesday evenings, 6:00 -9:05 pm

Learn:

- ⇒ Entry level math
- ⇒ field related vocabulary
- ⇒ safety skills



Make  
Something  
Happen!

Learn  
Something  
New!

### JOUR 10 Mass Media & Society

*What impact do mass media have on our society and on our world?*

### JOUR 18A-D Working on the Newspaper

*Become a staff member of The Gavilan Press, Gavilan's independent student newspaper, in print and online!*

- ◆ Work in print and online
- ◆ Earn units toward a Media Arts Degree
- ◆ Learn new writing, research and design skills
- ◆ Get published and build a portfolio of your work
- ◆ Gain work experience that will help you land a good job
- ◆ Become part of a team
- ◆ Support free speech at Gavilan College!

Sect. Type Room Instructor Hrs. Units Days Begin-End Footnotes

### LIB 140 Online Health Research

Transferable: CSU

A beginning course on how to find reliable and current health-related information, using the internet and other electronic resources. This course is also listed as AH 140.

4568 ONLINE MEADERS 4.60 2.0 DHR 0000-0000 11 25 38  
03/31/08 - 05/23/08 This online class will be delivered entirely over the internet. After enrolling, start the class by going to <http://www.gavilan.edu/disted/>, click on your class link and email the instructor at [smeader@gavilan.edu](mailto:smeader@gavilan.edu). Students who have not begun the class or contacted the instructor by 5 pm on April 3 will be dropped from the class.



### LIB 732 Introduction to Online Gavilan

Transferable: No

Introduction to the online classes and student services at Gavilan College. This course will show students how to log into their online courses, find lectures, assignments and exams, take part in online class discussions, submit attachments, and view their grades. The course will also cover all the online student services available to the distant student, including counseling, library resources, records and grades, financial aid, tutoring and technical support.

4572 ONLINE PARKERJ 1.00 .0 DHR 0000-0000  
This online class will be delivered entirely over the Internet. After enrolling, start the class by going to <http://www.gavilan.edu/disted/>, click on your class link, and email the instructor at [jparker@gavilan.edu](mailto:jparker@gavilan.edu). Students who have not begun the class or contacted the instructor by 5 pm on Feb. 4 will be dropped from the class



Mass Media: see JOUR 10

## MATHEMATICS

### MATH 1A Single-Variable Calculus and Analytic Geometry

Prerequisite: Mathematics 10 or Math 205A/205B class

that is part of the Basic Skills pilot program. 8B with a grade of 'C' or better.

Transferable: CSU; UC; CSU-GE: B4; IGETC: 2A; GAV-GE: B4; CAN: MATH 18, MATH SEQ. B

Limits and continuity, analyzing the behavior and graphs of functions, derivatives, implicit differentiation, higher order derivatives, related rates and optimization word problems, Newton's Method, Fundamental Theorem of Calculus, and definite and indefinite integrals.

6137 LEC PB4 JUKL H 4.60 4.0 M W 0600P-0805P 1 15

### MATH 1B Single-Variable Calculus and Analytic Geometry

Prerequisite: Mathematics 1A with a grade of 'C' or better.

Transferable: CSU; UC; CSU-GE: B4; IGETC: 2A; GAV-GE: B4; CAN: MATH 20, MATH SEQ. B

This course is a standard second semester Calculus course covering methods of integration, applications of the integral, differential equations, parametric and polar equations, and sequences and series.

4576 LEC SS206 DACHKOVAE 4.20 4.0 MWF 1250P-0200P 1 15

## Don't forget

A counselor's signature is required if you take over 17.99 units (spring/fall) or over 5.99 units (summer).

You do not need a counselor's signature to register for a class with a prerequisite that was successfully completed at Gavilan.

Sect. Type Room Instructor Hrs. Units Days Begin-End Footnotes

### MATH 1C Multivariable Calculus

Prerequisite: Mathematics 1B with a grade of 'C' or better.

Transferable: CSU; UC; CSU-GE: B4; IGETC: 2A; GAV-GE: B4; CAN: MATH 22, MATH SEQ. C

A standard third semester Calculus course covering functions of several variables, vectors, surfaces, vector-valued functions, partial derivatives, multiple and line integrals, Green's Theorem, Stokes' Theorem, and the Divergence Theorem.

6138 LEC PB9 STAFF 4.60 4.0 M W 0600P-0805P 15

### MATH 5 Introduction to Statistics

Prerequisite: Mathematics 233 with a grade of 'C' or better.

Transferable: CSU; UC; CSU-GE: B4; IGETC: 2A; GAV-GE: B4; CAN: STAT 2

Descriptive analysis and presentation of either single-variable data or bivariate data, probability, probability distributions, normal probability distributions, sample variability, statistical inferences involving one and two populations, analysis of variance, linear correlation and regression analysis. Statistical computer software will be extensively integrated as a tool in the description and analysis of data.

4577 LEC PB13 LITTIG A 4.30 3.0 MW 0810A-0930A 1  
PB14 LITTIG A F 0810A-0900A

4578 LEC PB16 JUKL H 4.30 3.0 TuTh 1120A-1240P 1  
PB14 JUKL H F 1140A-1230P

4579 LEC PB3 BUTTERWORTH Y 4.30 3.0 M 0230P-0435P 1  
BUTTERWORTH Y W 0230P-0335P  
LAB PB 14 BUTTERWORTH Y W 0345P-0435P

6139 LEC PB13 STAFF 4.30 3.0 S 1200P-0205P 1 13  
ONLINE STAFF DHR 0000-0000



This hybrid lecture/online class will be delivered partially over the Internet. See the online syllabus for details. <http://www.gavilan.edu/disted/>.

6140 LEC MHG12 VIARENGO A 4.20 3.0 M W 0600P-0805P 1  
Above class meets at Morgan Hill Community site

6141 LEC HOL4 LITTIG A 4.30 3.0 Tu 0700P-0905P 1  
LITTIG A Th 0700P-0805P  
HOL3 LITTIG A 0825P-0915P  
Above class meets at the Hollister Briggs site

### MATH 6 Calculus for Business/Social Science

Prerequisite: Mathematics 233 with a grade of 'C' or better.

Transferable: CSU; UC; CSU-GE: B4; IGETC: 2A; GAV-GE: B4; CAN: MATH 34

This course applies the fundamental principles and techniques of calculus to problems in business, economics, the life sciences and the social sciences. Topics will include limits, and differentiation and integration of linear, quadratic, polynomial, exponential and logarithmic functions. This course is not intended for students majoring in engineering, the physical sciences or math. Using a calculator is required. Graphing calculator is recommended.

4580 LEC PB13 GUENTHER J 3.20 3.0 TuTh 0810A-0930A 1

### MATH 7 Finite Mathematics

Prerequisite: Mathematics 233 with a grade of 'C' or better.

Transferable: CSU; UC; CSU-GE: B4; IGETC: 2A; GAV-GE: B4; CAN: MATH 12

Systems of linear equations and matrices, introduction to linear programming, finance, counting techniques and probability, properties of probability and applications of probability.

4581 LEC SS206 DRESCH M 3.20 3.0 TuTh 1250P-0210P 1 15

### MATH 8A First Half of Precalculus

Prerequisite: Mathematics 233 with a grade of 'C' or better.

Transferable: CSU; UC; CSU-GE: B4; IGETC: 2A; GAV-GE: B4

Math 8A prepares the student for the study of calculus by providing important skills in algebraic manipulation, interpretation, and problem solving at the college level. Topics will include basic algebraic concepts, complex numbers, equations and inequalities of the first and second degree, functions, and graphs, linear and quadratic equations, polynomial functions, exponential and logarithmic functions, systems of equations, matrices and determinants, right triangle trigonometry, and the Law of Sines and Cosines.

4582 LEC SS210 WAGMAN K 4.20 4.0 MWF 0945A-1055A 1 15

6142 LEC PB13 SEENE M 4.60 4.0 TuTh 0600P-0805P 1 15

Sect. Type Room Instructor Hrs. Units Days Begin-End Footnotes

**MATH 8B Second Half of Precalculus**

**Prerequisite:** Mathematics 8A with a grade of 'C' or better.

**Advisory:** Math 208 Survey of Practical Geometry.

**Transferable:** CSU; UC; CSU-GE: B4; IGETC: 2A; GAV-GE: B4

Math 8B prepares students for the study of calculus by providing important skills in algebraic manipulation, interpretation, and problem solving at the college level. Topics will include trigonometric functions, identities, inverse trigonometric functions, and equations; applications of trigonometry, vectors, complex numbers, polar and parametric equations; conic sections; sequences, series, counting principles, permutations, mathematical induction; analytic geometry, and an introduction to limits.

4583 LEC PB3 DWYER M 4.20 4.0 MWF 1250P-0200P 1 15

**MATH 14 Math for the Liberal Arts**

**Prerequisite:** Math 233 with a grade of 'C' or better.

**Transferable:** CSU; UC; CSU-GE: B4; IGETC: 2A; GAV-GE: B4

Survey of selected topics from contemporary mathematics to introduce the student to mathematical thinking for the non-specialist. Topics include systems of numeration, algebraic modeling, linear programming, trigonometry, math of finance, probability and statistics, and an introduction to calculus.

6143 LEC PB8 KERCEVAL S 3.30 3.0 Th 0600P-0905P 1

**MATH 201A Math for Science and Engineering**

**Corequisite:** Enrollment in appropriate section of Math 205 which is part of a learning community.

**Transferable:** No

This course will provide a combination of math study skills, introduction to scientific equipment and technology for mathematics, analysis of data from various branches of science, one or more field trips, investigation of educational plans and program choices at the transfer level.

**LEARNING COMMUNITY SECTION:**

4584 LEC SS206 DRESCH M 1.00 1.0 F 0930A-1020A 1 36

Above class is part of a learning community. You must enroll in both courses. See ad on page 78.

**MATH 201B Math for Science and Engineering**

**Corequisite:** Enrollment in appropriate section of Math 233 which is part of a learning community.

**Transferable:** No

This course will provide a combination of math study skills, introduction to scientific equipment and technology for mathematics, collection and analysis of data from various branches of science, one or more field trips, investigation of science careers and program choices at the transfer level.

**LEARNING COMMUNITY SECTION:**

4585 LEC PB3 DWYER M 1.00 1.0 F 0920A-1010A 1 36

Above class is part of a learning community. You must enroll in both courses. See ad on page 78.

**MATH 205 Elementary Algebra**

**Prerequisite:** MATH 402 with a grade of 'C' or better or assessment test recommendation.

**Transferable:** No; GAV-GE: B4

This course is a standard beginning algebra course, including algebraic expressions, linear equations and inequalities in one variable, graphing, equations and inequalities in two variables, integer exponents, polynomials, rational expressions and equations, radicals and rational exponents and quadratic equations. Mathematics 205, 205A and 205B and 206 have similar course content. This course may not be taken by students who have completed Mathematics 205B or 206 with a grade of "C" or better. This course may be taken for Mathematics 205B credit (2.5 units) by those students who have successfully completed Mathematics 205A with a grade of "C" or better.

4586 LEC PB3 DWYER M 5.40 5.0 DAILY 0810A-0900A 1

4587 LEC MHG13 KERCEVAL S 5.40 5.0 MTuWTh 0945A-1050A 1

Above class meets at Morgan Hill Community site

**LEARNING COMMUNITY SECTION:**

4588 LEC SS206 DRESCH M 5.40 5.0 MTuWTh 0945A-1050A 1 36

Above class is part of a learning community. You must enroll in both courses. See ad on page 78.

4589 LEC PB3 WAGMAN K 5.40 5.0 MTuWTh 1120A-1225P 1

4590 LEC HOL5 GUENTHER J 5.40 5.0 MTuWTh 1250P-0155P 1

Above class meets at the Hollister Briggs site

4591 LEC PB4 WAGMAN K 5.40 5.0 MTuWTh 1250P-0155P 1

4592 LEC PB4 JUKL H 5.40 5.0 MTuWTh 0230P-0335P 1

6144 LEC PB13 LEE R 5.40 5.0 M W 0600P-0825P 1

6145 LEC MHG13 BUTTERWORTH 5.40 5.0 TuTh 0600P-0825P 1

Above class meets at Morgan Hill Community site

**Gavilan College  
Overview of Math Courses**

Grade of "C" or better required in order to progress to the next course

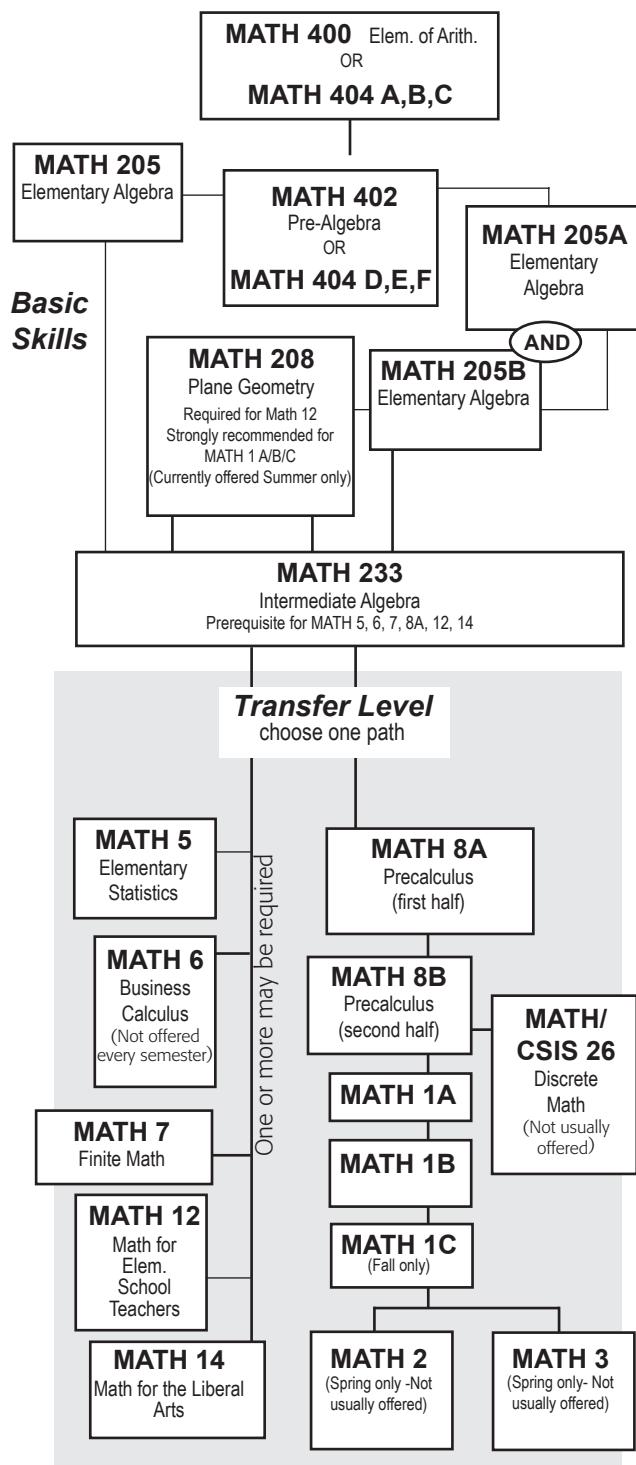

**Multiple measures will be considered to determine your final course. Consult with a counselor to select the appropriate course.**



Sect. Type Room Instructor Hrs. Units Days Begin-End Footnotes

**MATH 205A First Half of Elementary Algebra**

**Prerequisite:** Effective Fall 2005: MATH 402 with a grade of 'C' or better or assessment test recommendation.

**Advisory:** Concurrent enrollment in Guidance 563A is advised.

**Transferable:** No; GAV-GE: B4

This course is the first half of the Elementary Algebra course. It will cover signed numbers, evaluation of expressions, ratios and proportions, solving linear equations, and applications. Graphing of lines, the slope of a line, graphing linear equations, solving systems of equations, basic rules of exponents, and operations on polynomials will be covered.

4593	LEC	SS206 PB4	LOCKHART L LOCKHART L	4.20	2.5	TuTh F	1250P-0200P	1
4594	LEC	PB5	LOCKHART L	4.60	2.5	MTuWTh	0230P-0435P	1
01/30/08-03/20/08 Students are encouraged to follow this 8-week class with Math 205B, sect. 4597.								
4807	LEC	HU104	DACHKOVA E	4.60	2.5	MTuWTh	0330P-0535P	1
03/31/08-05/23/08								

**MATH 205B Second Half of Elementary Algebra**

**Prerequisite:** Math 205A with a grade of 'C' or better.

**Advisory:** Concurrent enrollment in Guidance 563B is advised.

**Transferable:** No; GAV-GE: B4

This course contains the material covered in the second half of the Elementary Algebra Course. It will cover factoring, polynomials, solving quadratic equations by factoring, rational expressions and equations, complex fractions, radicals and radical equations, solving quadratic equations by completing the square and the quadratic formula. Application problems are integrated throughout the topics.

4595	LEC	SS206	WASHBURN A	4.20	2.5	MWF	0810A-0920A	1
4596	LEC	SS206 PB4	KIM D KIM D	4.20	2.5	TuTh F	1120A-1230P 1120A-1230P	1
4597	LEC	PB5	LOCKHART L	4.60	2.5	MTuWTh	0230P-0435	1
03/31/08-05/23/08								
6146	LEC	SS206	GROVER MJ	4.60	2.5	TuTh	0600P-0805P	1



**Close Encounters with Math and Science**

- Have you ever thought about a career in science, engineering, or math, but doubted your ability to get through the math classes required?
- Are you looking for a supportive environment to help you with your math?
- Have you ever wondered how math applies to real world problems?
- Would you like to gain some hands-on experience with tools and techniques of science?



For more information about this exciting new program contact math instructor Marlene Dwyer in PB11A, call (408) 848-4897, or email mdwyer@gavilan.edu

Sect. Type Room Instructor Hrs. Units Days Begin-End Footnotes

**MATH 233 Intermediate Algebra**

**Prerequisite:** Mathematics 205 or Mathematics 205A and 205B or Mathematics 206 with a grade of 'C' or better.

**Transferable:** No; GAV-GE: B4

Review of basic concepts, linear equations and inequalities, graphs and functions, systems of linear equations, polynomials and polynomial functions, factoring, rational expressions and equations, roots, radicals, and complex numbers, solving quadratic equations, exponential and logarithmic functions, and problem solving strategies. Mathematics 233, 233A, and 233B have similar course content. This course may not be taken by students who have completed Mathematics 233B with a grade of 'C' or better. This course may be taken for Mathematics 233B credit (2.5) units by those students who have successfully completed Mathematics 233A with a grade of 'C' or better.

4598	LEC	PB4	DRESCH M	5.40	5.0	DAILY	0810A-0900A	1
4599	LEC	MHG11	FULLER G	5.20	5.0	MTuWTh	0945A-1050A	1
Above class meets at Morgan Hill Community site								

**LEARNING COMMUNITY SECTION:**

4600	LEC	PB3	DWYER M	5.20	5.0	MTuWTh	0945A-1050A	136
Above class is part of a learning community. You must enroll in both courses. See ad below.								

4601	LEC	PB4	DACHKOVA E	5.40	5.0	MTuWTh	1120A-1225P	1
4602	LEC	HOL2	MALOKAS J	5.40	5.0	MTuWTh	1250P-0155P	1
Above class meets at the Hollister Briggs site								
4603	LEC	PB13	LEE R	5.40	5.0	MTuWTh	1250P-0155P	1
4604	LEC	SS206	VIARENGO A	5.40	5.0	MTuWTh	0400P-0505P	1
6147	LEC	HOL2	BATES R	5.40	5.0	TuTh	0600P-0825P	1
Above class meets at the Hollister Briggs site								
6148	LEC	PB3	KIM D	5.40	5.0	TuTh	0600P-0825P	1



**MATH 233A First Half of Intermediate Algebra**

**Prerequisite:** Completion of Mathematics 205 or the equivalent with a grade of 'C' or better.

**Transferable:** No

The course will start with a review of basic concepts and then cover the following topics with an emphasis on applications and problem solving strategies: solving linear equations; solving linear, compound, and absolute value inequalities; equations and graphs of lines; functions and function notation including composition of functions; solving systems of linear equations and inequalities; an introduction to matrices and Cramer's rule; operations with polynomials; factoring polynomials; and solving polynomial equations.

4605	LEC	PB8	SEENEM	4.20	2.5	TuThF	1120A-1230P	1
------	-----	-----	--------	------	-----	-------	-------------	---

Then these Learning Communities are for you! **Sign up for:**

**MATH 233 Intermediate Algebra** sect. 4600 MTuWTh 945A-1050A

**MATH 201B Math for Science & Engineering** sect. 4585 F 920A-1010A

OR

**MATH 205 Elementary Algebra** sect. 4588 MTuWTh 945A-1050A

**MATH 201A Math for Science & Engineering** sect. 4584 F 930A-1020A

Sect. Type Room Instructor Hrs. Units Days Begin-End Footnotes



**MATH 233B Second Half of Intermediate Algebra**

**Prerequisite:** Completion of MATH 233A with a grade of 'C' or better.

**Transferable:** No

This course will start with a review factoring polynomials, and then cover the following topics with an emphasis on applications and problem solving strategies: solving polynomial equations by factoring; adding, subtracting, multiplying, dividing and simplifying rational expressions and solving rational equations; adding, subtracting, multiplying, dividing and simplifying roots, radicals and complex numbers and solving radical equations; the various methods of solving quadratic equations and inequalities; graphing quadratic functions; and working with exponential and logarithmic functions, equations and expressions.

4606	LEC	SS206	NARI J	4.20	2.5	MWF	1120A-1230P	1
6149	LEC	PB5	LOCKHART L	4.20	2.5	TuTh	0600P-0805P	1

**MATH 400 Elements of Arithmetic**

**Transferable:** No

Essential arithmetic operations, whole numbers, integers, fractions, decimals, ratio, proportion, percent, applications of arithmetic, and critical thinking, as well as math-specific study skills. Units earned in this course do not count toward the associate degree and/or other certain certificate requirements.

4607	L/L	PB9	WASHBURN A WASHBURN A	4.20	3.0	MW F	0945A-1105A 1020A-1110A	1
4608	L/L	PB8	DACHKOVA E DACHKOVA E	4.20	3.0	TuTh F	0945A-1105A 0920A-1010A	1
6150	L/L	SS206	STAFF	4.20	3.0	M W	0600P-0805P	1

**MATH 402 Pre-Algebra**

**Prerequisite:** Completion of Math 400 with a 'C' or better, or assessment test recommendation.

**Transferable:** No

This course covers operations with integers, fractions and decimals and associated applications, percentages, ratio, and geometry and measurement, critical thinking and applications. Elementary algebra topics such as variables, expressions, and solving equations are introduced.

4609	L/L	PB8	FULLER G	4.20	3.0	TuThF	0810A-0920A	1
4610	L/L	PB13 PB4	JUKL H JUKL H	4.20	3.0	MW TuTh	0945A-1035A	1
4611	L/L	PB8	NARI J NARI J	4.20	3.0	MW F	1250P-0210P 1250P-0140P	1
6151	L/L	SS203	ARID A	4.20	3.0	TuTh	0600P-0805P	1

**Be Aware**

If your goal is a  
**MULTIPLE SUBJECT CREDENTIAL,**  
 you may need  
**MATH 12, Math for Elementary Teachers.**

**Have you met the prerequisite?**

**It's required!**

Footnotes contain valuable information pertaining to your class selection. Footnotes follow class listings.



**Enhanced Elementary Algebra  
 Math 205A/205B**

These classes are part of the Gavilan College Emerging Scholars pilot program.

Students can complete Math 205 while taking the 205A/205B courses and have additional time in the class to work on problems, counselor support and designated tutors working with students in class and out of class. Take:

**MATH 205A** sect. 4594 MTuWTh 2:30 pm-4:35 pm Dates: 1/30-3/20

**MATH 205B** sect. 4597 MTuWTh 2:30 pm-4:35 pm Dates: 3/31-5/23

Instructor for both courses: Lynn Lockhart  
 Location: PB5



**Tutoring Center**

[www.gavilan.edu/tutor](http://www.gavilan.edu/tutor)

408-848-4838  
 Located in LI 116



Free tutoring is available in a variety of subjects!

Work with a peer tutor and fellow students to develop a better understanding of course content.

**Fall/Spring Semester:**  
 Mon-Thurs: 8 am - 7:45 pm  
 Fri, 8 am - 4 pm

**Summer Session:** Call for hours

Debbie Roderick, Tutoring Program Coordinator  
 Sara Spencer, Evening Tutoring Specialist

Sect. Type Room Instructor Hrs. Units Days Begin-End Footnotes

**MATH 404A-G Self-Paced Basic Math**

These classes involve both lecture and hands-on computer components. All sections are open for late registration.  
Transferable: No

This course is a remedial, modular, self-paced course. Application and critical thinking skills are developed in each module. Module A covers operations with whole numbers, equivalent fractions, multiplying and dividing fractions. Module B covers adding and subtracting fractions, and operations with decimals. Module C covers ratio and proportion, percent, and units of measurement. Module D reviews fractions, decimals, percentages, and covers operations with integers, and working with variables. Module E covers real numbers, fractions, exponents, scientific notation, and order of operations. Module F covers expressions, polynomials, and equations. Module G covers geometric figures, perimeter and area, surface area and volume, triangles and parallelograms, and similar figures. This course has the option of a letter grade or credit/no credit.

**MATH 404A Self-Paced Basic Math**

4612 L/L PB14 DACHKOVA E 1.30 1.0 TuTh 1250P-0315P 179

**MATH 404B Self-Paced Basic Math**

4613 L/L PB14 DACHKOVA E 1.30 1.0 TuTh 1250P-0315P 179

**MATH 404C Self-Paced Basic Math**

4614 L/L PB14 DACHKOVA E 1.30 1.0 TuTh 1250P-0315P 179

**MATH 404E Self-Paced Basic Math**

4615 L/L PB14 DACHKOVA E 1.30 1.0 TuTh 1250P-0315P 179

**MATH 404F Self-Paced Basic Math**

4616 L/L PB14 DACHKOVA E 1.30 1.0 TuTh 1250P-0315P 179

**MATH 404G Self-Paced Basic Math**

4617 L/L PB14 DACHKOVA E 1.30 1.0 TuTh 1250P-0315P 179

**Medical Terminology: see Business**

**MUSIC**

**MUS 1A Music History and Literature**

Advisory: Eligible for English 250 and English 260.  
Transferable: CSU; UC; CSU-GE: C1; IGETC: 3A; GAV-GE: C1; CAN: MUS 8

A survey of the development of music in western civilization including representative composers from the Medieval to the present. Music 1A will study the music and styles from the Medieval to the Romantic period.

4618 LEC AL101 AMIRKHANIAN 3.20 3.0 MW 0945A-1105A

**MUS 1B Music History and Literature**

Advisory: Eligible for English 250 and English 260.  
Transferable: CSU; UC; CSU-GE: C1; IGETC: 3A; GAV-GE: C1

A survey of the development of music in western civilization including representative composers from the Medieval period to the present. Music 1B will study the music and styles from late Romanticism to the present.

4619 LEC AL101 JUNCKER A 3.20 3.0 TuTh 1120A-1240P

Sect. Type Room Instructor Hrs. Units Days Begin-End Footnotes

**MUS 3A Harmony - Theory - Musicianship**

Advisory: Must be taken in sequence.  
Transferable: CSU; UC; CSU-GE: C1; GAV-GE: C1  
Fundamentals of music, beginning harmony.

4620 L/L OE001 JUNCKER A 6.90 4.0 MW&2.3 0900A-1105A

**MUS 3B Harmony - Theory - Musicianship**

Advisory: Must be taken in sequence.  
Transferable: CSU; UC; GAV-GE: C1  
Fundamentals of music, beginning harmony.

4621 L/L AL101 JUNCKER A 6.90 4.0 MTuWTh&2.3 0810A-0900A

**MUS 3C Intermediate Harmony - Theory**

Advisory: Music 3B  
Transferable: CSU; UC; GAV-GE: C1  
Continuation of Music 3AB. Chromatic harmony, analysis and composition.

4622 L/L AL101 JUNCKER A 6.90 4.0 MTuWTh&2.3 0800A-0900A

**MUS 3D Intermediate Harmony - Theory**

Advisory: Music 3C  
Transferable: CSU; UC; GAV-GE: C1  
Continuation of Music 3C. Analysis and composition.

4623 L/L AL101 JUNCKER A 6.90 4.0 MTuWTh&2.3 0800A-0900A

**MUS 4A Beginning Piano**

Advisory: Must be taken in sequence.  
Transferable: CSU; UC; CSU-GE: C1; GAV-GE: C1

Introduction to music fundamentals and keyboard technique. Development of beginning keyboard skills including note reading in bass and treble clef, fingering, rhythm, key signatures, primary chords and inversions.

4624 L/L OE001 AMIRKHANIAN 4.60 3.0 MW 1120A-0125P

4625 L/L OE001 AMIRKHANIAN 4.60 3.0 TuTh 1250P-0255P

6152 L/L OE001 MELLO S 4.60 3.0 M&1 0630P-0935P

**MUS 4B Beginning Piano**

Advisory: Music 4A  
Transferable: CSU; UC; GAV-GE: C1  
Continuation of Music 4A.

4626 L/L OE001 AMIRKHANIAN 3.30 2.0 TuTh 1120A-1240P

6153 L/L OE001 MELLO S 3.30 2.0 M 0630P-0935P

**MUS 5A Intermediate Piano**

Advisory: Music 4B  
Transferable: CSU; UC; GAV-GE: C1

Development of intermediate keyboard skills through means of scales, chords, and technical studies. Continuation of music fundamentals and beginning keyboard harmony; introduction of easier classical and standard piano literature.

4627 L/L OE001 AMIRKHANIAN 3.30 2.0 TuTh 1120A-1240P

6154 L/L OE001 MELLO S 3.30 2.0 M 0630P-0935P

**Check Out Late Start Classes!**

Register anytime before the first day of class.  
Check the dates printed under the class section number.

Classroom Locations: Refer to "How to Use This Schedule" on page 6.

Sect.	Type	Room	Instructor	Hrs.	Units	Days	Begin-End	Footnotes
-------	------	------	------------	------	-------	------	-----------	-----------

**MUS 5B Intermediate Piano****Advisory:** Music 5A**Transferable:** CSU; UC; GAV-GE: C1

Development of intermediate keyboard skills through means of scales, chords and technical studies. Continuation of music fundamentals and beginning keyboard harmony; introduction of easier classical and standard piano literature.

4628 L/L OE001 AMIRKHANIAN 3.30 2.0 TuTh 1120A-1240P

6155 L/L OE001 MELLO S 3.30 2.0 M 0630P-0935P

**MUS 5C Advanced Piano****Advisory:** Music 5B**Transferable:** CSU; UC; GAV-GE: C1

Development of advanced keyboard skills through means of scales, chords and technical studies. Continuation of music fundamentals and keyboard harmony; introduction of moderately difficult classical and standard piano literature.

4629 L/L OE001 AMIRKHANIAN 3.30 2.0 TuTh 1120A-1240P

6156 L/L OE001 MELLO S 3.30 2.0 M 0630P-0935P

**MUS 5D Advanced Piano****Advisory:** Music 5C**Transferable:** CSU; UC; GAV-GE: C1

Development of advanced keyboard skills through means of scales, chords and technical studies. Continuation of music fundamentals and keyboard harmony; introduction of moderately difficult classical and standard piano literature.

4630 L/L OE001 AMIRKHANIAN 3.30 2.0 TuTh 1120A-1240P

6157 L/L OE001 MELLO S 3.30 2.0 M 0630P-0935P

**MUS 8A Beginning Voice****Advisory:** Continues in sequence or by demonstrated proficiency.**Transferable:** CSU; UC; GAV-GE: C1

Development of techniques in the art of singing and interpreting serious music in various styles. Study of the basic techniques of tone production, breathing and related skills. Basic repertoire development.

4631 L/L AL101 PRUITT N 3.30 2.0 TuTh 1250P-0210P

**MUS 8B Beginning Voice****Advisory:** Music 8A or demonstrated proficiency.**Transferable:** CSU; UC; GAV-GE: C1

Development of techniques in the art of singing and interpreting serious music in various styles. Study of the basic techniques of tone production, breathing and related skills. Basic repertoire development.

4632 L/L AL101 PRUITT N 3.30 2.0 TuTh 1250P-0210P

**MUS 8C Intermediate Voice****Advisory:** Music 8B or demonstrated proficiency.**Transferable:** CSU; UC; GAV-GE: C1

Development of techniques in the art of singing and interpreting serious music in various styles. Study of the basic techniques of tone production, breathing and related skills. Basic repertoire development.

4633 L/L AL101 PRUITT N 3.30 2.0 TuTh 1250P-0210P

**MUS 8D Intermediate Voice****Advisory:** Music 8C or demonstrated proficiency.**Transferable:** CSU; UC; GAV-GE: C1

Development of techniques in the art of singing and interpreting serious music in various styles. Study of the basic techniques of tone production, breathing and related skills. Basic repertoire development.

4634 L/L AL101 PRUITT N 3.30 2.0 TuTh 1250P-0210P



## Profile

### STAFF

**Richard Alfaro**

As the Director of TRIO, Student Support Services I work with approximately 160 first-generation students at Gavilan College. The TRIO program offers students a variety of services such as university visits, workshops, tutoring, counseling, and much more. Since I was a first-generation college student myself, it is an honor to return to Gavilan College in this new role.

I graduated from Gilroy High School in 1993 and decided to attend Gavilan College. However, I failed to complete any courses and decided to return to work. After three years of working the graveyard shift at a cardboard box factory, I quit my job to return to school full-time. I graduated with an Associate of Arts degree from Modesto Junior College, then transferred to CSU, Stanislaus. With hard work and commitment, I earned my Bachelor of Arts degree in Organizational Communications with a minor in Political Science.

Shortly after receiving my degree, I began working at Gavilan College as an Outreach and Recruitment Specialist. In this position, I was given the opportunity to build and create relationships with our service area high schools and students.

I left Gavilan College in 2003 to pursue an opportunity at Santa Clara University School of Law where I worked as a Law Admissions Counselor. During my employment at Santa Clara University, I was accepted into their graduate education program. After attending school part-time and working fulltime, I received my Master of Arts degree in Educational Administration. During my time at Santa Clara University I held many positions and even worked briefly at Stanford University. However I was eager to return to my community. I am very excited to be back at Gavilan College, and even more excited to work with our students in achieving their post-secondary goals!



Gavilan College  
**TUTORING CENTER**  
PB14

## FREE TUTORING!

Services for  
Gavilan Students:

**Free Tutoring for MATH**  
**Free Computer Assistance**

For daily schedule or for free Math downloads,  
check our website - <http://www.gavilan.edu/mathlab/>

Staffed by the Math Department

Sect. Type Room Instructor Hrs. Units Days Begin-End Footnotes

**MUS 9A Guitar**

**Advisory:** Students must provide their own guitars.  
**Transferable:** CSU; UC; GAV-GE: C1

An introduction to playing the guitar. Basic staff notation, correct fingering and chord arpeggios are covered. Emphasis is also placed on developing musical listening skills. Students must provide their own guitars. May be repeated once for credit.

4635	LAB	HOL6	MONTOYA T	3.30	1.0	M	0100P-0405P	
Above class meets at the Hollister Briggs site								
6158	LAB	AL101	MONTOYA T	3.30	1.0	M	0530P-0835P	

**MUS 9B Guitar**

**Advisory:** Music 9A; students must provide their own guitars.  
**Transferable:** CSU; UC; GAV-GE: C1

An introduction to playing the guitar. Basic staff notation, correct fingering and chord arpeggios are covered. Emphasis is also placed on developing musical listening skills. Students must provide their own guitars. May be repeated once for credit.

6159	LAB	AL101	MONTOYA T	3.30	1.0	M	0600P-0905P	
------	-----	-------	-----------	------	-----	---	-------------	--

**MUS 12 Vocal Ensemble**

**Transferable:** CSU; UC; GAV-GE: C1

The day Vocal Ensemble will focus on individual and group performance of popular and alternative commercial music, and will rehearse and perform with a backup band. The evening Vocal Ensemble will study, rehearse and perform choral music in a broad spectrum of musical genre and styles. Included will be the study of vocal and rehearsal techniques as they relate to ensemble performance. Course may be repeated three times for credit.

4636	L/L	AL101	JUNCKER A	4.30	2.0	M	1250P-0355P	
6160	L/L	GHS	ROBB P	4.30	2.0	Tu	0600P-0905P	67
See Footnote: Above class meets Off Campus								

**MUS 13 Concert Choir**

**Advisory:** Previous choral experience is preferred but not required. The student should have the ability to match a given pitch.  
**Transferable:** CSU; UC; GAV-GE: C1

The Concert Choir will study, rehearse and perform choral music from the 15th century to the present in a variety of musical styles with emphasis on the larger choral works and their preparation for public concert. Course may be repeated three times for credit.

6161	L/L	GHS	ROBB P	4.30	2.0	Tu&1	0600P-0905P	67
See Footnote: Above class meets Off Campus								

**MUS 14A Instrumental Ensemble**

**Transferable:** CSU; GAV-GE: C1

Instruction for the experienced musician with emphasis on the study and performance of a wide variety of musical styles from Renaissance to 20th century music for traditional ensembles, and extensive consideration of contemporary commercial and alternative repertoire, and performance techniques for popular ensembles.

4637	L/L	AL101	MARQUESA	4.30	2.0	M&1	1250P-0355P	
6162	L/L	SOLB7	QUARTUCCIO A	4.30	2.0	W&1	0600P-0905P	

**MUS 14B Instrumental Ensemble**

**Transferable:** CSU; GAV-GE: C1

Instruction for the experienced musician with emphasis on the study and performance of a wide variety of musical styles from Renaissance to 20th century music for traditional ensembles, and extensive consideration of contemporary commercial and alternative repertoire, and performance techniques for popular ensembles.

4638	L/L	AL101	MARQUESA	4.30	2.0	M&1	1250P-0355P	
6163	L/L	SOLB7	QUARTUCCIO A	4.30	2.0	W&1	0600P-0905P	

Sect. Type Room Instructor Hrs. Units Days Begin-End Footnotes

**MUS 14C Instrumental Ensemble**

**Transferable:** CSU; GAV-GE: C1

Instruction for the experienced musician with emphasis on the study and performance of a wide variety of musical styles from Renaissance to 20th century music for traditional ensembles, and extensive consideration of contemporary commercial and alternative repertoire, and performance techniques for popular ensembles.

4639	L/L	AL101	MARQUESA	4.30	2.0	M&1	1250P-0355P	
6164	L/L	SOLB7	QUARTUCCIO A	4.30	2.0	W&1	0600P-0905P	

**MUS 14D Instrumental Ensemble**

**Transferable:** CSU; GAV-GE: C1

Instruction for the experienced musician with emphasis on the study and performance of a wide variety of musical styles from Renaissance to 20th century music for traditional ensembles, and extensive consideration of contemporary commercial and alternative repertoire, and performance techniques for popular ensembles.

4640	L/L	AL101	MARQUESA	4.30	2.0	M&1	1250P-0355P	
6165	L/L	SOLB7	QUARTUCCIO A	4.30	2.0	W&1	0640P-0905P	

**MUS 22 Field Work and Service**

**Required:** Learning contracts must be filled out and signed by the student and the supervising instructor.

**Transferable:** CSU

Supervised field work within the college and with local agencies. Students serve in useful group activities in leadership roles prescribed for them by faculty or community agencies. A maximum of six units may be completed. This is a credit/no credit course.

4641	FEX	GHS	ROBB P	3.30	1.0	DHR	0000-0000	21 67
See Footnote: Above class meets Off Campus								
4642	FEX	AL101	QUARTUCCIO A	3.30	1.0	DHR	0000-0000	21

**MUS 23 Independent Study**

**Required:** The study outline prepared by the student and the instructor must be filed with the department and the dean.

**Transferable:** CSU

Designed to afford selected students specialized opportunities for exploring areas at the independent study level. The courses may involve extensive library work, research in the community, or special projects. May be repeated until six units of credit are accrued. This course has the option of a letter grade or credit/no credit.

4643	IND	OE001	MELLO S	3.30	1.0	DHR	0000-0000	22
4644	IND	GHS	ROBB P	3.30	1.0	DHR	0000-0000	22 67
See Footnote: Above class meets Off Campus								
4645	IND	AL101	QUARTUCCIO A	3.30	1.0	DHR	0000-0000	22
4646	IND	AL102	JUNCKER A	3.30	1.0	DHR	0000-0000	22
4647	IND	AL102	JUNCKER A	6.40	2.0	DHR	0000-0000	22
4648	IND	AL101	PRUITT N	3.30	1.0	DHR	0000-0000	22
4649	IND	AL101	PRUITT N	6.40	2.0	DHR	0000-0000	22
4650	IND	OE001	AMIRKHANIAN	3.30	1.0	DHR	0000-0000	22
4651	IND	OE001	AMIRKHANIAN	6.40	2.0	DHR	0000-0000	
6166	IND	AL101	MONTOYA T	3.30	1.0	M&3.3	0600P-0850P	22

**MUS 26 Symphony**

**Advisory:** Demonstrated proficiency on individual's instrument and ability to read music.

**Transferable:** CSU; UC; GAV-GE: C1

Study and performance of orchestral literature. Individual and sectional skills development. Perform in public concerts each semester. May be repeated until a maximum of 8 units are accrued.

6167	L/L	SOLB7	QUARTUCCIO A	4.30	2.0	W&1	0600P-0905P	
------	-----	-------	--------------	------	-----	-----	-------------	--

Sect. Type Room Instructor Hrs. Units Days Begin-End Footnotes

**MUS 28 Jazz/Pop Piano**

Advisory: Music 4A or the equivalent.

Transferable: CSU; UC; GAV-GE: C1

Introduction to jazz and popular piano: Chord symbols, chord voicings, improvisation, arrangements in blues, jazz, and other popular music styles. May be repeated three times for credit.

4652 L/L OE001 JUNCKER A 4.30 2.0 TuTh 0910A-1115A

**MUS 98 Special Topics**

Transferable: CSU; GAV-GE: C1

Special topics courses examine current problems or issues of interest to students within a specific discipline area. For topical content information, consult with appropriate department chairperson. For transfer status, check with a counselor. This course may have the option of a letter grade or credit/no credit.

6168 LEC GHS ROBB P 2.30 2.0 Tu&1 0600P-0905P 67  
See Footnote: Above class meets Off Campus

6169 LEC AL101 QUARTUCCIO A 2.30 2.0 W&1 0600P-0905P

**Nursing: see Allied Health**

**Nutrition: see Biological Sciences**

**Performing Arts: see Theatre Arts (THEA)**

**PHILOSOPHY**

**PHIL 1 Introduction to Philosophy**

Advisory: Eligible for English 1A.

Transferable: CSU; UC; CSU-GE: C2; IGETC: 3B; GAV-GE: C2; CAN: PHIL 2

Philosophy 1 is intended as a survey of the major areas and traditions of philosophy. The course examines central and significant questions about the meaning of life, who determines what is morally right or wrong, the ideal society, the various notions social justice, what is reality, and many other ideas. In pursuing these questions, students will be asked to read texts from writers around the world, both contemporary and ancient, discuss current events, and apply 'theory' to movies such as "The Matrix" trilogy, novels, and any other relevant application of the student's own choice.

4726 LEC HOL1 HODGE E 3.20 3.0 TuTh 0810A-0930A  
Above class meets at the Hollister Briggs site

4727 LEC HU105 HODGE E 3.20 3.0 MW 0230P-0350P

**PHIL 2 Logic**

Advisory: Eligible for English 1A.

Transferable: CSU; UC; CSU-GE: A3; GAV-GE: C2; CAN: PHIL 6

Philosophy 2 is intended as a survey of the primary approaches to argumentation and what has been traditionally called 'correct' reasoning. Students will learn techniques of both deductive and inductive argumentation, basic symbolic logic, how to spot a fallacy, as well as how to apply these techniques to other aspects of their lives outside of the classroom. While logic is often quite formal, the goal is to see the practical application of this discipline. Students will become acquainted with the cultural variations to reasoning in addition to the standard Western focal approach.

4728 LEC SS110 HODGE E 3.20 3.0 MW 1120A-1240P

**PHIL 3B Contemporary Moral Issues**

Advisory: Eligible for English 1A.

Transferable: CSU; UC; CSU-GE: C2; IGETC: 3B; GAV-GE: C2, E2

Contemporary Moral Issues in an applied ethics class that covers major ethical theories and contemporary moral issues in a pluralistic manner. This course will cover such issues as abortion and euthanasia, cloning, experimentation on human subjects, capital punishment, race/ethnicity, sexual orientation and sexual morality, world hunger and poverty, colonialism and post-colonialism, and so forth.

4729 LEC MHG3 GRUDZEN G 3.20 3.0 TuTh 1250P-0210P  
Above class meets at Morgan Hill Community site



*The most fun you'll ever have in a class!*

**MUS 12  
Vocal Ensemble**

Play:  
Rock & Roll  
Jazz

**MUS 14A  
Instrumental  
Ensemble**

Blues  
Top Hits  
Classics  
Your original songs!

*Arrange a personal tour!*

Call 408-846-4993.

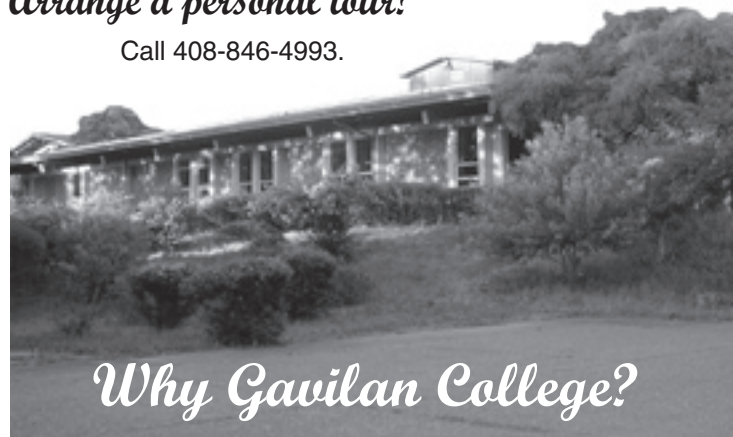

*Why Gavilan College?*

- Complete first two years of college coursework**
- Easy transfer to UC, CSU and private universities**
- Learn job skills**
- Classes scheduled morning, afternoon and evening**
- A variety of locations to serve your needs**
- Excellent faculty/helpful staff**
- Small classes**
- Beautiful campus**
- No Silicon Valley commute**
- Close to home and work**
- Affordable**

Sect. Type Room Instructor Hrs. Units Days Begin-End Footnotes

**PHIL 4 Critical Thinking and Writing**

Prerequisite: English 1A

Transferable: CSU; UC; CSU-GE: A3; IGETC: 1B; GAV-GE: C2

This course is designed to introduce the relationship between critical thinking and critical writing in a way that will be both enjoyable to the student and helpful in other aspects of life. The student will learn techniques of critical thinking, paying close attention to the current events, movies and popular media, music lyrics, as well as the textbook. Students will learn to identify deductive and inductive arguments and be able to evaluate their strength, create a strong argument of their own on a given topic, as well become experts in the area of critical analysis. The goal is to enable students to become strong, well informed, articulate members of the community as well as individuals with an empowered sense of self as an agent of change.

4730	LEC	AR103	HODGE E	3.20	3.0	MW	0945A-1105A
4731	LEC	HOL1	JOHNSTON M	3.20	3.0	TuTh	1120A-1240P

Above class meets at the Hollister Briggs site

**PHIL 6B Philosophy of Religions**

Advisory: Eligible for English 1A.

Transferable: CSU; UC; CSU-GE: C2; IGETC: 3B; GAV-GE: C2, E2

A reflective examination and analysis of the meanings and beliefs involved in religion and the religious experience. Introductory study of such topics as the nature and grounds of religious belief, relation between religion and ethics, nature and existence of god, problem of evil, and what can be learned from the religious experience. Additionally, the student will discuss the impact of religion on society, social norms, and the political impact of religion.

4732	LEC	SS110	HODGE E	3.20	3.0	TuTh	1250P-0210P
------	-----	-------	---------	------	-----	------	-------------

**PHIL 23 Independent Study**

Required: The study outline prepared by the student and the instructor must be filed with the department and the dean.

Transferable: CSU

Designed to afford selected students specialized opportunities for exploring areas at the independent study level. The courses may involve extensive library work, research in the community, or special projects. May be repeated until six units of credit are accrued. This course has the option of a letter grade or credit/no credit.

4733	IND	SS106	HODGE E	3.30	1.0	DHR	0000-0000
------	-----	-------	---------	------	-----	-----	-----------

**Photography: see Art, CSIS or Digital Media**

**PHYSICAL EDUCATION: ACADEMIC**

**PE 3A Athletic Training Field Experience**

Advisory: PE 3 Introduction to Athletic Training.

Transferable: CSU

A coeducational course designed to offer the prospective athletic trainer, physical therapist, or physical educator a continuing practical experience reinforcing and applying the concepts and terminology learned in PE 3, Introduction to Athletic Training, and the field of athletic training. The purpose of PE 3A is to provide a comprehensive, progressive educational and practical foundation in preparation for transition into allied health studies. Knowledge in the recognition, assessment, and care of athletic injuries or practical experience in care and prevention of athletic injuries is recommended. May be repeated three times for credit. This course has the option of a letter grade or credit/no credit.

4656	LAB	GY131G	BEYMER H	6.80	2.0	DHR	0000-0000
------	-----	--------	----------	------	-----	-----	-----------

**PE 5 Individual and Dual Sports**

Advisory: Eligible for English 250 and English 260.

Transferable: CSU; UC; GAV-GE: E1

Designed for those planning to work with children in the field of physical education or recreation. Activities such as badminton, bowling, golf, tennis, and archery may be covered. This course has the option of a letter grade or credit/no credit.

4657	L/L	APE120	LANGO J	5.70	3.0	MW&2	1120A-1240P
------	-----	--------	---------	------	-----	------	-------------

Sect. Type Room Instructor Hrs. Units Days Begin-End Footnotes



**PE 9A Fundamentals of Soccer**

Transferable: CSU; UC; GAV-GE: E1

This course offers basic instruction in the theory, strategies, and techniques of soccer for the purpose of preparing the individual student in the fundamental aspects of playing and coaching the sport. May be repeated once for credit. This course has the option of a letter grade or credit/no credit.

4659	L/L	GY131G	MARQUESA	4.20	2.0	TuTh	0230P-0415P
------	-----	--------	----------	------	-----	------	-------------

**PE 9B Fundamentals of Soccer**

Transferable: CSU; UC; GAV-GE: E1

This course offers review and advanced instruction in the theory, strategies, and techniques of soccer for the purpose of preparing the individual student in all aspects of playing and coaching the sport. May be repeated once for credit. This course has the option of a letter grade or credit/no credit.

4660	L/L	GY131G	MARQUESA	4.20	2.0	TuTh	0230P-0415P
------	-----	--------	----------	------	-----	------	-------------

**PE 13A Fundamentals of Volleyball**

Transferable: CSU; UC

This course offers basic instruction in the theory, strategies, and techniques of volleyball for the purpose of preparing the student in the fundamental aspects of playing and coaching the game. May be repeated once for credit. This course has the option of a letter grade or credit/no credit.

4661	L/L	GY131G	KRAMER K	4.20	2.0	MW	1250P-0230P
------	-----	--------	----------	------	-----	----	-------------

**PE 13B Fundamentals of Volleyball**

Advisory: Physical Education 13A.

Transferable: CSU

This course offers review and advanced instruction in the theory, strategies, and techniques of volleyball for the purpose of preparing the student in all aspects of playing and coaching the game. May be repeated once for credit. This course has the option of a letter grade or credit/no credit.

4662	L/L	GY131G	KRAMER K	4.20	2.0	MW	1250P-0230P
------	-----	--------	----------	------	-----	----	-------------

**PHYSICAL EDUCATION: ACTIVITIES**

**PE 16 Swimming**

Transferable: CSU; UC; CSU-GE: E1; GAV-GE: E1

Coeducational activity designed for all skill levels. The course teaches the techniques of a variety of strokes and includes conditioning activities. Instruction is tailored to meet individual and group needs. May be repeated three times for credit. This course has the option of a letter grade or credit/no credit.

4663	LAB	GY100P	DODD S	3.20	1.0	MW	1250P-0210P
4664	LAB	GY100P	DODD S	6.40	.5	MW	1250P-0210P 11

03/31/08 - 05/21/08

**PE 17 Golf**

Transferable: CSU; UC; CSU-GE: E1; GAV-GE: E1

Coeducational activity designed for all skill levels; fundamentals, techniques, rules and etiquette of golf. May be repeated three times for credit. This course has the option of a letter grade or credit/no credit.

4665	LAB	GY200C	KRAMER K	3.30	1.0	F	1040A-0135P 49
6172	LAB	GY200C	KRAUSE S	3.40	.5	S	0900A-1155A 11 43 49

03/29/08 - 05/17/08

Sect. Type Room Instructor Hrs. Units Days Begin-End Footnotes

**PE 20 Bowling**

Transferable: CSU; UC; CSU-GE: E1; GAV-GE: E1

Coeducational activity designed for beginning and intermediate bowlers; fundamentals and techniques of bowling. Scoring, bowling etiquette, terminology and team bowling are included. May be repeated three times for credit. This course has the option of a letter grade or credit/no credit.

4666 LAB GIBOWL LANGO J 3.20 1.0 TuTh 0810A-0930A 62  
See Footnote: Above class meets Off Campus

**PE 21 Volleyball**

Transferable: CSU; UC; CSU-GE: E1; GAV-GE: E1

Coeducational activity designed for beginning and intermediate volleyball students; rules, strategy and fundamentals of volleyball. May be repeated three times for credit. This course has the option of a letter grade or credit/no credit.

4667 LAB GY131G KRAMER K 3.20 1.0 MW 1250P-0210P  
6173 LAB GY131G KRAMER K 3.30 1.0 Th 0600P-0905P

**PE 23 Independent Study**

Required: The study outline prepared by the student and the instructor must be filed with the department and the dean.

Transferable: CSU

Designed to afford selected students specialized opportunities for exploring areas at the independent study level. The courses may involve extensive library work, research in the community, or special projects. May be repeated until six units of credit are accrued. This course has the option of a letter grade or credit/no credit.

4668 IND GY116 DODD S 6.40 2.0 DHR 0000-0000 22

**PE 24 Individualized Weight Training**

Transferable: CSU; UC; CSU-GE: E1; GAV-GE: E1

An open laboratory for those who desire an individualized strength program using exercise machines and free weights. May be repeated three times for credit. This course has the option of a letter grade or credit/no credit.

4669 LAB GY123 DODD S 3.20 1.0 Day/Time - See instructor 87  
For lab hours see ad on page 87.  
4670 LAB GY123 DODD S 1.60 .5 Day/Time - See instructor 87  
For lab hours see ad on page 87.

**PE 25 Soccer**

Transferable: CSU; UC; CSU-GE: E1; GAV-GE: E1

Co-educational activity designed for all skill levels. Fundamentals, strategy and rules of the game are included. May be repeated three times for credit. This course has the option of a letter grade or credit/no credit.

4671 LAB GY131G ANDRADE N 3.20 1.0 MW 0810A-0930A

**PE 27 Basketball**

Transferable: CSU; UC; CSU-GE: E1; GAV-GE: E1

Co-educational activity designed for all skill levels. Fundamentals, strategy and rules of the game are included. May be repeated three times for credit. This course has the option of a letter grade or credit/no credit.

4672 LAB GY131G ADDISON T 3.40 .5 TuTh 0230P-0430P 11  
04/01/08 - 05/22/08

**PE 39 Fencing**

Transferable: CSU; UC; CSU-GE: E1; GAV-GE: E1

This course will explore the offensive and defensive fencing skills with a foil. May be repeated three times credit. This course has the option of a letter grade or credit/no credit.

6174 LAB APE101 DECESARE J 3.30 1.0 M 0600P-0905P 44

Footnotes contain valuable information pertaining to your class selection. Footnotes follow class listings.

Help Build the Team!  
All are Welcome!



**PE 9A**

Fundamentals  
of  
SOCCER



2007 Men's Soccer Team

**Spring Sports**



- Baseball
- Basketball
- Women's Softball

Also check out the following Activity Classes...

- Aerobics
- Bowling
- Cardio Fitness
- Dance
- Golf
- Pilates
- Soccer
- Swimming
- Volleyball
- Yoga



Students wishing to participate in the intercollegiate athletic programs must be enrolled in and attending a minimum of 12 units during the first season of competition with a minimum of nine units applying towards a degree program.

For more information, contact the Athletic Department at 848-4876.



Sect. Type Room Instructor Hrs. Units Days Begin-End Footnotes

## PE 44 Aerobics

Transferable: CSU; UC; CSU-GE: E1; GAV-GE: E1

A program of aerobic fitness. Includes various forms of exercise to improve health, heart, and body composition. May be repeated three times for credit. This course has the option of a letter grade or credit/no credit.

4688 LAB GY131G THOMPSON N 3.20 1.0 MW 1120A-1240P

## PE 46 Agility and Motor Development

Transferable: CSU; UC; CSU-GE: E1; GAV-GE: E1

An activity class designed to improve and increase agility and motor development through various exercise and exercise programs. May be repeated three times for credit. This course has the option of a letter grade or credit/no credit.

4689 LAB GY131G LANGO J 3.20 1.0 MTuWTh 0310P-0400P  
4690 LAB GY131G LANGO J 3.20 .5 MTuWTh 0310P-0400P 11  
03/31/08 - 05/22/08

## PE 61 Swim for Fitness

Transferable: CSU; UC; CSU-GE: E1; GAV-GE: E1

Designed to develop endurance and swimming skills in order to maintain good cardiovascular/physical fitness. Intermediate swimming ability recommended. May be repeated three times for credit. This course has the option of a letter grade or credit/no credit.

6175 LAB GY100P DODD S 3.20 .5 TuTh 0515P-0635P 11  
04/01/08 - 05/22/08

## PE 62 Yoga

Transferable: CSU; UC; CSU-GE: E1; GAV-GE: E1

Co-educational activity designed for beginning yoga students. A program designed to improve flexibility and reduce stress, by learning a series of postures and focusing on proper breathing techniques. May be repeated three times for credit. This course has the option of a letter grade or credit/no credit.

4691 LAB APE101 WATSON M 3.20 1.0 MW 1250P-0210P  
6176 LAB MHG10 WATSON M 3.20 1.0 M W 0500P-0620P  
Above class meets at Morgan Hill Community site  
6178 LAB PHALL MUSCARI D 3.20 1.0 TuTh 0500P-0620P 41  
See Footnote: Above class meets Off Campus

## PE 64 Individualized Cardiovascular Fitness

Transferable: CSU; UC; CSU-GE: E1; GAV-GE: E1

A fitness program which develops cardiovascular endurance through an individualized open lab format. May be repeated three times for credit. This course has the option of a letter grade or credit/no credit.

4692 LAB GY123 DODD S 3.20 1.0 Day/Time - See instructor 87  
For lab hours see ad on page 87.  
4693 LAB GY123 DODD S 1.70 .5 Day/Time - See instructor 87  
For lab hours see ad on page 87.

## PE 70 Pilates

Transferable: CSU; UC; CSU-GE: E1; GAV-GE: E1

This class utilizes the Pilates exercise system focused on improving flexibility and strength for the total body through a series of controlled movements. May be repeated three times for credit. This course has the option of a letter grade or credit/no credit.

4695 LAB APE101 MUSCARID 3.20 1.0 TuTh 1250P-0210P  
6179 LAB PHALL MUSCARI D 3.20 1.0 TuTh 0630P-0750P 41  
Above class meets at Portuguese Hall, Hollister. See page 6 for a list of off-campus locations.

Sect. Type Room Instructor Hrs. Units Days Begin-End Footnotes

## PE 73 Fitness Through Dance

Transferable: CSU; UC; CSU-GE: E1; GAV-GE: E1

Conditioning the body through the use of various dances and/or dance steps. This course is designed to strengthen and tone the body, assist in weight loss, and increase endurance. May be repeated three times for credit. This course has the option of a letter grade or credit/no credit.

4696 LAB APE 101 DODD S 3.20 1.0 TuTh 1120A-1240P



## PE 75 Sports Conditioning

Transferable: CSU; UC; CSU-GE: E1; GAV-GE: E1

This activity class is designed to improve the physical condition of male and female athletes. It includes strength training, cardiovascular endurance, plyometric training, and sport specific techniques. May be repeated three times for credit. This course has the option of a letter grade or credit/no credit.

4697 LAB GY123 NICHOLS B 3.20 1.0 Day/Time - See instructor 87  
For lab hours see ad on page 87.

4698 LAB GY123 NICHOLS B 1.60 .5 Day/Time - See instructor 87  
For lab hours see ad on page 87.



## PE 76 Marathon Training

Transferable: CSU; UC; CSU-GE: E1; GAV-GE: E1

This course is designed to train individuals for participation in long-distance events. May be repeated three times for credit. This course has the option of a letter grade or credit/no credit.

6180 LAB GY131G STAFF 3.30 1.0 S 0810A-1100A

## PHYSICAL EDUCATION: ADAPTED

### PE 34 Adapted Aquatic Exercise

Transferable: CSU; UC; CSU-GE: E1; GAV-GE: E1

Designed to help individuals who by the nature of their disability such as wheelchair use, back injury, cardiovascular impairment, multiple sclerosis or other disabling condition require a specific aquatic exercise program that will contribute to their physical well-being. May be repeated as necessary based on measurable progress as documented in the student's educational contract. This course has the option of a letter grade or credit/no credit.

4673 LAB GY100P ELLIS D 3.40 1.0 MW 0810A-0930A 90 75  
4674 LAB GY100P ELLIS D 3.40 1.0 MW 1120A-1240P 90 75  
4675 LAB GY100P ELLIS D 3.40 1.0 TuTh 1120A-1240P 90 75  
CRETIN A

### PE 35 Adapted Swimming for Total Fitness

Transferable: CSU; UC; CSU-GE: E1; GAV-GE: E1

An individualized program of activities designed for students with physical disabilities to improve flexibility and range-of-motion, increase joint movement, improve circulation, and improve control of body movement through water adjustment and activities. Develops an appreciation of physical activity as a regular planned contribution to one's overall well-being. May be repeated as necessary based on measurable progress as documented in the student's educational contract. This course has the option of a letter grade or credit/no credit.

4676 LAB GY100P ELLIS D 3.40 1.0 MW 0810A-0930A 90 75  
4677 LAB GY100P ELLIS D 3.40 1.0 MW 1120A-1240P 90 75  
4678 LAB GY100P ELLIS D 3.40 1.0 TuTh 1120A-1240P 90 75  
CRETIN A

Sect. Type Room Instructor Hrs. Units Days Begin-End Footnotes

**PE 36 Adapted Physical Education**

Transferable: CSU; UC; CSU-GE: E1; GAV-GE: E1

An individualized program of adaptive physical education activities designed to meet the needs of students with physical disabilities. Develops an appreciation of physical activity as a regular planned contribution to one's overall well-being. May be repeated as necessary based on measurable progress as documented in the student's educational contract. This course has the option of a letter grade or credit/no credit.

4679	LAB	APE108	ELLIS D	3.40	1.0	MW	0945A-1105A	90 75
4680	LAB	APE108	ELLIS D	3.40	1.0	TuTh	0945A-1105A	90 75
4681	LAB	APE108	ELLIS D	3.40	1.0	MW	1250P-0210P	90 75
4682	LAB	APE108	ELLIS D	3.40	1.0	TuTh	1250P-0210P	90 75

**PE 38 Adapted Cardiovascular Conditioning & Training**

Transferable: CSU; UC; CSU-GE: E1; GAV-GE: E1

Prescribed exercises in weight training, stretching and cardiovascular conditioning for those individuals that have been disabled through stroke, cardiovascular accident, arthritis, multiple sclerosis, or other condition. May be repeated as necessary based on measurable progress as documented in the student's educational contract. This course has the option of a letter grade or credit/no credit.

4684	LAB	APE108	ELLIS D	3.40	1.0	MW	0945A-1105A	90 75
4685	LAB	APE108	ELLIS D	3.40	1.0	TuTh	0945A-1105A	90 75
4686	LAB	APE108	ELLIS D	3.40	1.0	MW	1250P-0210P	90 75
4687	LAB	APE108	ELLIS D	3.40	1.0	TuTh	1250P-0210P	90 75

**PE 534 Adapted Aquatic Exercise**

Transferable: No

Designed to help individuals who by the nature of their disability such as wheelchair use, back injury, cardiovascular impairment, multiple sclerosis or other disabling condition require a specific aquatic exercise program that will contribute to their physical well being. May be repeated as necessary based on measurable progress as documented in the student's educational contract. This is a credit/no credit course.

4699	LAB	GY100P	ELLIS D	3.40	1.0	MW	0810A-0930A	90 75
4700	LAB	GY100P	ELLIS D	3.40	1.0	MW	1120A-1240P	90 75
4701	LAB	GY100P	ELLIS D CRETINA	3.40	1.0	TuTh	1120A-1240P	90 75

**PE 535 Adapted Swimming for Total Fitness**

Transferable: No

An individualized program of activities designed for students with physical disabilities to improve flexibility and range-of-motion, increase joint movement, improve circulation, and improve control of body movement through water adjustment and activities. Develops an appreciation of physical activity as a regular planned contribution to one's overall well-being. May be repeated as necessary based on measurable progress as documented in the student's educational contract. This course is credit/no credit.

4703	LAB	GY100P	ELLIS D	3.40	1.0	MW	0810A-0930A	90 75
4704	LAB	GY100P	ELLIS D	3.40	1.0	MW	1120A-1240P	90 75
4705	LAB	GY100P	ELLIS D CRETINA	3.40	1.0	TuTh	1120A-1240P	90 75

**ATH 35 Basketball**

**ATH 38 Baseball**

**ATH 45 Softball**



**GO RAMS!**

**PE 21 Volleyball**

Thursday Evenings: 6:00-9:05 pm

**NEW Evening section!**

**PE 24 Individualized Weight Training**

**PE 64 Cardiovascular Fitness**

**Spring Semester Fitness Center Lab Hours**

Day	MWF	7:00 am - 2:00 pm
	TuTh	8:00 am - 2:00 pm
Eve.	MTuWTh	4:30 pm - 6:30 pm

- Section hours by arrangement
- ✦ 1.7 to 3.4 weekly hours
  - ✦ .5 or 1.0 unit
  - ✦ Fitness Center (GYM 123)



**Open Lab Class Format**  
Designed for individualized strength or cardiovascular fitness programs in an open lab setting using a variety of exercise equipment.

**Students should check in the first week of the semester during lab hours.**

Students should be aware that there are inherent risks involved in any physical exercise. Students are strongly advised to consult a physician prior to participating in any physical education activity.



Appropriate footwear is required in all gym facilities. No barefeet permitted.

**PE Activities** Classes can be taken for letter grade or CR/NC.

Sect. Type Room Instructor Hrs. Units Days Begin-End Footnotes

**PE 536 Adapted Physical Education**

Transferable: No

An individualized program of adaptive physical education activities designed to meet the needs of students with physical disabilities. Develops an appreciation of physical activity as a regular planned contribution to one's overall well-being. May be repeated as necessary based on measurable progress as documented in the student's educational contract. This is a credit/no credit course.

4706	LAB	LOADCS	CRETINA	3.40	1.0	MW	0945A-1105A	70 90 75
See Footnote: Above class meets Off Campus								
4707	LAB	APE108	ELLIS D	3.40	1.0	MW	0945A-1105A	90 75
4708	LAB	APE108	ELLIS D	3.40	1.0	TuTh	0945A-1105A	90 75
4710	LAB	LOADCS	MARINGER J	3.30	1.0	F	0945A-1105A	
See Footnote: Above class meets Off Campus								
4711	LAB	APE101	ELLIS D	3.30	1.0	F	0945A-1250P	
See Footnote: Above class meets Off Campus								
4712	LAB	HOLLCC	CRETINA	3.40	1.0	MW	1120A-1240P	68 90 75
See Footnote: Above class meets Off Campus								
4713	LAB	APE108	ELLIS D	3.40	1.0	MW	1250P-0210P	90 75
4714	LAB	APE108	ELLIS D	3.40	1.0	TuTh	1250P-0210P	90 75

**PE 538 Adapted Cardiovascular Conditioning & Training**

Transferable: No

Prescribed exercises in weight training, stretching and cardiovascular conditioning for those individuals that have been disabled through stroke, cardiovascular accident, arthritis, multiple sclerosis, or other condition. May be repeated as necessary based on measurable progress as documented in the student's educational contract. This is a credit/no credit course.

4715	LAB	APE108	ELLIS D	3.40	1.0	MW	0945A-1105A	90 75
4716	LAB	APE108	ELLIS D	3.40	1.0	TuTh	0945A-1105A	90 75
4717	LAB	LOADCS	CRETINA	3.40	1.0	TuTh	0945A-1105A	70 75
See Footnote: Above class meets Off Campus								
4718	LAB	APE108	ELLIS D	3.40	1.0	MW	1250P-0210P	90 75
4719	LAB	APE108	ELLIS D	3.40	1.0	TuTh	1250P-0210P	90 75

**INTERCOLLEGIATE ATHLETICS**

**ATH 35 Basketball**

Transferable: CSU; UC; CSU-GE: E1; GAV-GE: E1

This course provides practice and competition in intercollegiate basketball. May be repeated three times for credit. This course has the option of a letter grade or credit/no credit.

4131	LAB	GY131G	ADDISON T	10.00	1.0	DAILY	0230P-0430P	11
01/30/08 - 03/11/08								

**ATH 38 Baseball**

Transferable: CSU; UC; CSU-GE: E1; GAV-GE: E1

This course provides practice and competition in intercollegiate baseball for men. May be repeated three times for credit. This course has the option of a letter grade or credit/no credit.

4132	LAB	GY131G	ANDRADE N	10.00	2.0	DAILY	0230P-0430P	
------	-----	--------	-----------	-------	-----	-------	-------------	--

**ATH 45 Softball**

Transferable: CSU; UC; CSU-GE: E1; GAV-GE: E1

This course provides practice and competition in intercollegiate softball for women. May be repeated three times for credit. This course has the option of a letter grade or credit/no credit.

4133	LAB	GY131G	THOMPSON N	10.00	2.0	DAILY	0230P-0430P	
------	-----	--------	------------	-------	-----	-------	-------------	--

Sect. Type Room Instructor Hrs. Units Days Begin-End Footnotes

**PHYSICAL SCIENCE**

**PSCI 1 Principles of Physical Science**

Advisory: Mathematics 205 and eligible for English 250 and 260.

Transferable: CSU; UC; CSU-GE: B1; IGETC: 5A; GAV-GE: B1

An introduction to the physical sciences for the non-science major. Attention is focused on fundamental laws of nature, their development and relation to the physical world.

4747	LEC	SS205	STAFF	3.20	3.0	MW	0810A-0930A	
------	-----	-------	-------	------	-----	----	-------------	--

6182	LEC	HOL1	SNYDER J	3.30	3.0	Tu	0630P-0935P	
Above class meets at the Hollister Briggs site								

**PSCI 2 Introduction to Meteorology**

Advisory: MATH 205.

Transferable: CSU; UC; CSU-GE: B1; IGETC: 5A; GAV-GE: B1

An introductory course in Meteorology that is both descriptive and analytical on the physical principles affecting the earth's weather. Topics covered include the nature of the atmosphere, solar energy, heat, temperature, pressure, stability, moisture, wind, storms, severe weather and forecasting. The course introduces climatology as a scientific study and will look at the earth's climatic history, current research in climate modeling and the possibility of global climate change.

4748	LEC	ONLINE	VANTUYLA	3.30	3.0	DHR	0000-0000	
------	-----	--------	----------	------	-----	-----	-----------	--

This online class will be delivered entirely over the internet. After enrolling, start the class by going to <http://www.gavilan.edu/disted/>, click on your class link and email the instructor at [avantuyla@gavilan.edu](mailto:avantuyla@gavilan.edu). Students who have not begun the class or contacted the instructor by 5 pm on Feb.4 will be dropped from the class.



**PHYSICS**

**PHYS 1 Introduction to Physics**

Advisory: Mathematics 205.

Transferable: CSU; UC; CSU-GE: B1, B3; IGETC: 5A; GAV-GE: B1, B3

This course is an introduction to the fundamental physical principles that control the world around us. Students will explore the fundamental principles of physics, their historical development, their application to everyday phenomena, and their impact upon political, social, and environmental issues. Laboratory exercises will explore the everyday world.

4734	L/L	PB13	LEER	6.40	4.0	TuTh	0945A-1250P	1
------	-----	------	------	------	-----	------	-------------	---

**PHYS 2B General Physics**

Prerequisite: Physics 2A

Advisory: Eligible for English 250 and English 260

Transferable: CSU; UC; CSU-GE: B1, B3; IGETC: 5A; GAV-GE: B1, B3; CAN: PHYS 4, PHYS SEQ. A

An introduction to the principles of physics using algebra and trigonometry. Topics include electricity and magnetism, light and optics, modern physics, and an introduction to relativity.

4735	L/L	PB13	LEER	6.40	4.0	MW	1120A-1240P	1
			LEER			W	0230P-0435P	
			LEER			F	1140A-1230P	

**Physiology: see Biological Sciences**

**Your educational plan:**

You are expected to take the responsibility for scheduling an appointment with a counselor, preferably at least once a semester. The purpose of this appointment is to develop, review and update your educational plan to ensure that you are taking the appropriate courses to meet your educational goal.

Sect. Type Room Instructor Hrs. Units Days Begin-End Footnotes

**POLITICAL SCIENCE**

**POLS 1 Introduction to American Government**

**Advisory:** Eligible for English 250 and English 260.

**Transferable:** CSU; UC; CSU-GE: D8; IGETC: 4H, 7A; GAV-GE: D1, D2; CAN: GOVT 2

Explores the development of American political institutions and their utilization in dealing with issues arising at the international, national and state levels. Emphasis is placed on those problems which have defined our federal system of government. California government and appropriate state institutions will be included as a vital part of our federal system of government.

4736	LEC	SS210	TURETZKY M	3.20	3.0	MW	0810A-0930A	
4737	LEC	SS210	TURETZKY M	3.20	3.0	TuTh	0810A-0930A	
4738	ONLINE	TURETZKY M	3.30	3.0	DHR	0000-0000	38	This online class will be delivered entirely over the internet. After enrolling, start the class by going to <a href="http://www.gavilan.edu/disted/">http://www.gavilan.edu/disted/</a> , click on your class link and email the instructor at <a href="mailto:mturetzky@gavilan.edu">mturetzky@gavilan.edu</a> . Students who have not begun the class or contacted the instructor by 5 pm on Feb. 4 will be dropped from the class.
4739	ONLINE	TURETZKY M	3.30	3.0	DHR	0000-0000		This online class will be delivered entirely over the internet. After enrolling, start the class by going to <a href="http://www.gavilan.edu/disted/">http://www.gavilan.edu/disted/</a> , click on your class link and email the instructor at <a href="mailto:mturetzky@gavilan.edu">mturetzky@gavilan.edu</a> . Students who have not begun the class or contacted the instructor by 5 pm on Feb. 4 will be dropped from the class.
6181	LEC	SS210	TURETZKY M	3.30	3.0	Tu	0600P-0905P	

**POLS 3 Introduction to Comparative Politics**

**Advisory:** Eligible for English 250 and English 260.

**Transferable:** CSU; UC; CSU-GE: D8; IGETC: 4H; GAV-GE: D2, F

Comparative survey of political institutions and processes around the globe. Selected nations may include, but are not restricted to: the United Kingdom, France, Germany, Japan, Russia, India, Nigeria, and Mexico.

4740	LEC	L1171	TURETZKY M	3.20	3.0	MW	1120A-1240P	
------	-----	-------	------------	------	-----	----	-------------	--

**POLS 4 Introduction to International Relations**

**Transferable:** CSU; UC; CSU-GE: D8; IGETC: 4H; GAV-GE: D2, F

This course provides an introduction to key contemporary international problems and the means to analyze them. Major parts of the course cover such topics as war and peace, foreign policymaking, the international economy, and future trends in world politics.

4741	LEC	ONLINE	TURETZKY M	3.30	3.0	DHR	0000-0000	38	This online class will be delivered entirely over the internet. After enrolling, start the class by going to <a href="http://www.gavilan.edu/disted/">http://www.gavilan.edu/disted/</a> , click on your class link and email the instructor at <a href="mailto:mturetzky@gavilan.edu">mturetzky@gavilan.edu</a> . Students who have not begun the class or contacted the instructor by 5 pm on Feb. 4 will be dropped from the class.
------	-----	--------	------------	------	-----	-----	-----------	----	--

**POLS 6 Introduction to Conflict Resolution**

**Advisory:** English 250 and English 260.

**Transferable:** CSU; CSU-GE: D7; GAV-GE: D2

Introduction to Conflict Resolution introduces students to conflict resolution and mediation. Integrating theory and practice, students will assess core concepts about the causes and resolution of conflict, and will practice communication skills for conflict resolution. Students will examine how ethnicity, gender, and class affect power in conflict situations. They will be able to formulate appropriate conflict resolution strategies, and will develop and practice various basic co-mediation skills. This course has the option of a letter grade or credit/no credit. This course is also listed as AJ 6 and PSYC 6 and CMUN 6.

4742	LEC	SS205	HALPER L	3.20	3.0	MW	0945A-1105A	25
------	-----	-------	----------	------	-----	----	-------------	----

**POLS 22 Field Work and Service**

**Required:** Learning contracts must be filled out and signed by the student and the supervising instructor.

**Transferable:** CSU

Supervised field work within the college and with local agencies. Students serve in useful group activities in leadership roles prescribed for them by faculty or community agencies. A maximum of six units may be completed. This is a credit/no credit course.

4743	FEX	SS107	TURETZKY M	3.30	1.0	DHR	0000-0000	21
------	-----	-------	------------	------	-----	-----	-----------	----

CSIS 61

Offered Thursday evenings, 6-9:50 pm in BU 111 (on the Gilroy main campus)

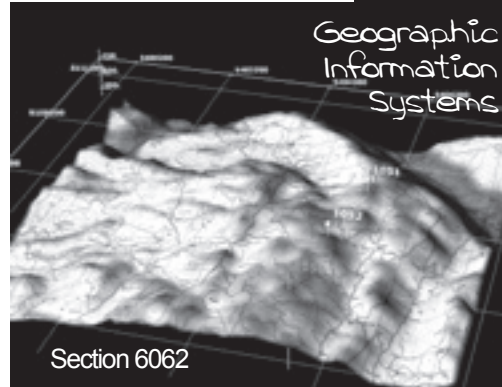

What do Administration of Justice, Biology, Business, Ecology, Economics, Geography, Geology, History, Landscaping, Public Health, Urban Planning, and Zoology have in common? GIS!

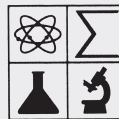

**MESA**

MATHEMATICS • ENGINEERING • SCIENCE ACHIEVEMENT

- ◆ Are you a math based major? (BIO, CSIS, Architecture, etc.)
- ◆ Do you want to transfer to a 4-year university?
- ◆ Do you have financial need? You may be eligible!

Gavilan's MESA Program is now accepting applications. MESA students are entitled to workshops, academic advising, field trips, tutoring and more!

For more information call 408-848-4887 or visit the MESA Study Center in PB16.

◆ [www.gavilan.edu/MESA](http://www.gavilan.edu/MESA) ◆

MATH • ENGINEERING • SCIENCE MAJORS

***PLANNING TO TRANSFER?***

Admission for these majors is very competitive

4-year universities stress preparation for the major over completion of general education major.

High-unit majors do not need to fulfill all general education requirements

You do not need to get an AA or AS degree to transfer

You should plan your sequential courses early.



can help you plan your courses to complete major preparation prior to transfer. Go to [www.assist.org](http://www.assist.org) and see a counselor to develop an educational plan.

Sect. Type Room Instructor Hrs. Units Days Begin-End Footnotes

**POLS 23 Independent Study**

**Required:** The study outline prepared by the student and the instructor must be filed with the department and the dean.  
**Transferable:** CSU

Designed to afford selected students specialized opportunities for exploring areas at the independent study level. The courses may involve extensive library work, research in the community, or special projects. May be repeated until six units of credit are accrued. This course has the option of a letter grade or credit/no credit.

4744	IND	SS107	TURETZKY M	3.30	1.0	DHR	0000-0000	22
4745	IND	SS107	TURETZKY M	3.30	1.0	DHR	0000-0000	22

**POLS 27 Contemporary Leadership**

**Advisory:** Eligible for English 250 and English 260.  
**Transferable:** CSU; GAV-GE: E2

A cross-disciplinary approach to the theory and practice of leadership. Includes effective communication styles including issues related to gender and culture. Class includes topics on ethics, power, and how to run effective meetings including the use of parliamentary procedure. Skills directly applicable to work, personal and college environments. May be repeated for a maximum of 10 units. Also listed as PSYC 27.

4746	L/L	SC154S	STEWART J	4.60	3.0	TuTh&2	0945A-1105A	25
------	-----	--------	-----------	------	-----	--------	-------------	----

**PSYCHOLOGY**

**PSYC 1A Introduction to Psychology**

**Advisory:** Eligible for English 250 and English 260.  
**Transferable:** CSU; UC; CSU-GE: D9; IGETC: 4I; GAV-GE: D2; CAN: PSY 2

The nature, scope, methods, presuppositions, history, and fields of psychology together with the scientific study of factors influencing human behavior, human development, perception, learning, memory, emotion, personality, frustration, and psychotherapy.

4749	LEC	SS214	OLER C	3.20	3.0	MW	0810A-0930A	
4750	LEC	SS214	HINN G	3.20	3.0	TuTh	0810A-0930A	
4751	LEC	HOL2	OLER C	3.20	3.0	TuTh	1120A-1240P	
Above class meets at the Hollister Briggs site								
4752	LEC	MHG11	CAMPILLI J	3.20	3.0	TuTh	1120A-1240P	
Above class meets at Morgan Hill Community site								
4753	LEC	SS210	OLER C	3.20	3.0	MW	0230P-0350P	
6183	LEC	SS214	CAMPILLI J	3.30	3.0	M	0600P-0905P	
6184	LEC	MHG10	OLER C	3.30	3.0	Th	0600P-0905P	
Above class meets at Morgan Hill Community site								

**PSYC 1B Introduction to Psychology**

**Advisory:** Psychology 1A  
**Transferable:** CSU; UC; CSU-GE: D9; IGETC: 4I; GAV-GE: D2

Continuation of Psychology 1A. This course stresses the biological basis of behavior including: neuroanatomy, the senses, perception, learning, thinking, and psychological disorders.

4754	LEC	SS214	OLER C	3.20	3.0	MW	0945A-1105A	
------	-----	-------	--------	------	-----	----	-------------	--

**PSYC 2 Early Child Development**

**Advisory:** Eligible for English 250 and English 260.  
**Transferable:** CSU; UC; CSU-GE: D9, E ; IGETC: 4I; GAV-GE: D2

A systematic study of the child from prenatal life through the preschool years. The course integrates the basic concepts of physical, cognitive and psychosocial development at each major stage of life during this period. This course is also listed as CD 2. This course has the option of a letter grade or credit/no credit.

4755	LEC	ONLINE	BUMGARNER M	3.30	3.0	DHR	0000-0000	
01/30/08 - 05/28/08 This online class will be delivered entirely over the internet. After enrolling, start the class by going to <a href="http://www.gavilan.edu/disted/">http://www.gavilan.edu/disted/</a> , click on your class link and email the instructor at <a href="mailto:mbumgarner@gavilan.edu">mbumgarner@gavilan.edu</a> . Students who have not begun the class or contacted the instructor by 5 pm on Feb. 4 will be dropped from the class.								

6185	LEC	BU120	CLABAUGH D	3.30	3.0	Th	0600P-0905P	
------	-----	-------	------------	------	-----	----	-------------	--

Sect. Type Room Instructor Hrs. Units Days Begin-End Footnotes

**PSYC 3 Child Growth and Development During the School Years**

**Advisory:** Eligible for English 250 and English 260; Psychology 2.  
**Transferable:** CSU; UC; CSU-GE: D9, E ; IGETC: 4I; GAV-GE: D2

Continuation of the study of child development with emphasis on children from six years of age through adolescence. Includes developmental theories and topics relevant to these ages. This course is also listed as CD 3. This course has the option of a letter grade or credit/no credit.

4756	LEC	MHG4	BUMGARNER M	3.20	3.0	MW	1120A-1240P	25
Above class meets at Morgan Hill Community site								
6186	LEC	HOL5	MUSCARI D	3.30	3.0	W	0600P-0905P	25
Above class meets at the Hollister Briggs site								

**PSYC 5 Self-Assessment and Career Development**

**Advisory:** Eligible for English 250 and English 260.  
**Transferable:** CSU; CSU-GE: E2; GAV-GE: E2

A course designed to assist the student in learning more about personal values, personality, interests, exploration of career choice, and occupational opportunities through the use of various personal assessment instruments. The delivery options for this course include online and self-paced formats. This course is also listed as GUID 1.

4757	LEC	HOL2	LOPEZ A	2.30	2.0	W	0230P-0435P	25 89
Above class meets at the Hollister Briggs site								
4758	LEC	PB13	GODLEY J	2.30	2.0	Th	0230P-0435P	25 89
4759	ONLINE	SHARBONEAU		2.30	2.0	DHR	0000-0000	25 38 89



This online class will be delivered entirely over the internet. After enrolling, start the class by going to <http://www.gavilan.edu/disted/>, click on your class link and email the instructor at [rsharboneau@gavilan.edu](mailto:rsharboneau@gavilan.edu). Students who have not begun the class or contacted the instructor by 5 pm on Feb. 4 will be dropped from the class.

**PSYC 6 Introduction to Conflict Resolution**

**Advisory:** English 250 and English 260.  
**Transferable:** CSU; CSU-GE: D7; GAV-GE: D2

Introduction to Conflict Resolution introduces students to conflict resolution and mediation. Integrating theory and practice, students will assess core concepts about the causes and resolution of conflict, and will practice communication skills for conflict resolution. Students will examine how ethnicity, gender, and class affect power in conflict situations. They will be able to formulate appropriate conflict resolution strategies, and will develop and practice various basic co-mediation skills. This course has the option of a letter grade or credit/no credit. This course is also listed as AJ 6 and POLS 6 and CMUN 6.

4760	LEC	SS205	HALPERL	3.20	3.0	MW	0945A-1105A	25
------	-----	-------	---------	------	-----	----	-------------	----

**PSYC 22 Field Work and Service**

**Required:** Learning contracts must be filled out and signed by the student and the supervising instructor.  
**Transferable:** CSU

Supervised field work within the college and with local agencies. Students serve in useful group activities in leadership roles prescribed for them by faculty or community agencies. A maximum of six units may be completed. This is a credit/no credit course.

4761	FEX	SS202A	OLER C	3.30	1.0	DHR	0000-0000	21
------	-----	--------	--------	------	-----	-----	-----------	----

**PSYC 23 Independent Study**

**Required:** The study outline prepared by the student and the instructor must be filed with the department and the dean.  
**Transferable:** CSU

Designed to afford selected students specialized opportunities for exploring areas at the independent study level. The courses may involve extensive library work, research in the community, or special projects. May be repeated until six units of credit are accrued. This course has the option of a letter grade or credit/no credit.

4762	IND	SS202A	OLER C	6.40	2.0	DHR	0000-0000	22
------	-----	--------	--------	------	-----	-----	-----------	----

Sect. Type Room Instructor Hrs. Units Days Begin-End Footnotes

**PSYC 27 Contemporary Leadership**

**Advisory:** Eligible for English 250 and English 260.  
**Transferable:** CSU; GAV-GE: E2

A cross-disciplinary approach to the theory and practice of leadership. Includes effective communication styles including issues related to gender and culture. Class includes topics on ethics, power, and how to run effective meetings including the use of parliamentary procedure. Skills directly applicable to work, personal and college environments. May be repeated for a maximum of 10 units. Also listed as POLS 27.

4763 L/L SC154N STEWART J 4.60 3.0 TuTh&2 0945A-1105A 25

**PSYC 52 Peer Counseling**

**Advisory:** Eligible for English 250 and English 260.  
**Transferable:** CSU

An overview of the principles, skills, and methods used in peer counseling. Course emphasizes using communication skills, goal setting, intervention techniques and evaluation for peer counselors and others.

4764 LEC PB12 LISTER T 2.30 2.0 Th 1250P-0255P

**Public Speaking: see Communications**

**REAL ESTATE**

**RE 160 Real Estate Principles**

**Advisory:** Eligible for English 250, English 260 and Mathematics 205.  
**Transferable:** CSU

The fundamental course covering an introduction to the field of real estate. Provides understanding, background and terminology necessary for advanced specialized courses. Will meet requirements for the Real Estate Sales License. This course has the option of a letter grade or credit/no credit.

6187 LEC BU118 FRIMANN G 6.40 3.0 M W 0630P-0935P 11  
 01/30/08 - 03/19/08

**RE 162 Real Estate Practice**

**Advisory:** Real Estate 160  
**Transferable:** CSU

Introduction to the practice of real estate in California; emphasis on the practical application of listings, selling, advertising, financing, escrow, taxation, and valuation of real estate. This course meets a requirement for the California o credit.License. This course has the option of a letter grade or credit/no credit. May be repeated three times for credit.

6188 LEC BU118 FRIMANN G 6.40 3.0 M W 0630P-0935P  
 03/31/08 - 05/19/08

**RE 163 Real Estate Finance**

**Advisory:** Real Estate 160  
**Transferable:** CSU

This course covers an analysis of real estate financing transactions in residential, apartment, commercial, and special purpose properties. Various methods of financing properties are emphasized in the course. This course meets a requirement for the California Broker's License. This course has the option of a letter grade or credit/no credit. May be repeated three times for credit.

6189 LEC BU118 BANKS S 3.30 3.0 S 0830A-1130A

**Skin Care: see COS 220, 221**

**Footnotes contain valuable information pertaining to your class selection. Footnotes follow class listings.**

**POLS 27 Contemporary Leadership**

Section 4746 Tu/Th, 9:45 - 11:05 am, N/S Lounges

Make a difference.  
 Your voice counts.

Also listed as PSYC 27

Photo courtesy of the Nelson Mandela Foundation

**ASB** Associated Student Body

Today – *Shaping the policies of the college.*  
 Tomorrow – *Shaping the policies of the world.*

**Join Student Government**  
 (408) 848-4777

**Campus under construction  
 ROOM NUMBERS MAY CHANGE!**

Check room numbers online before your first class.

Sect. Type Room Instructor Hrs. Units Days Begin-End Footnotes

**SOCIOLOGY**

**SOC 1A Introduction to Sociology**

Advisory: Eligible for English 250 and English 260.

Transferable: CSU; UC; CSU-GE: D0; IGETC: 4J; GAV-GE: D2; CAN: SOC 2

Analysis of the structure and dynamics of human society focusing on the development of culture, the socialization process, group behavior, social inequality, deviance, sexism, racism, and ageism, major social institutions, and human ecology. Emphasizes contemporary American society.

4765	LEC	HOL1	CERVANTES E	3.20	3.0	MW	0810A-0930A
Above class meets at the Hollister Briggs site							
4766	LEC	SS214	KREIDER R	3.20	3.0	TuTh	0945A-1105A
4767	LEC	SS205	KREIDER R	3.20	3.0	MW	0230P-0350P
6190	LEC	SS210	FAUTT M	3.30	3.0	Th	0600P-0905P

**SOC 1B Introduction to Sociology: Social Problems**

Advisory: Sociology 1A

Transferable: CSU; UC; CSU-GE: D0; IGETC: 4J; GAV-GE: D2; CAN: SOC 4

Sociology 1B is a course centering on the application of sociological concepts to the analysis of human ecology, social movements, social change, deviance and other selected social problems. Emphasis is placed on the study and analysis of problems in contemporary American society.

4768	LEC	SS205	GADBAN P	3.20	3.0	TuTh	1120A-1240P
------	-----	-------	----------	------	-----	------	-------------

**SOC 3 Sociology of Race and Ethnicity**

Advisory: Eligible for English 250 and English 260.

Transferable: CSU; UC; CSU-GE: D0; IGETC: 4J; GAV-GE: D2, F

This course is designed to introduce students to the basic sociological concepts and theories of race, ethnicity and cultural identity in U.S. society. Students will examine race, ethnicity and cultural identity as social constructs that permeate social structures and institutions, and how they change over time and space. Over the semester students will critically analyze the ways which race, ethnicity, class, and gender/sexuality continually shape peoples lives and experiences. While the class focuses on U.S. societies, students will also critically compare and contrast race and ethnicity in other societies.

4769	LEC	SS205	KREIDER R	3.20	3.0	TuTh	1250P-0210P
------	-----	-------	-----------	------	-----	------	-------------

**SOC 4 Sociology of Women and Men**

Advisory: Eligible for English 250 and English 260.

Transferable: CSU; UC; CSU-GE: D0, D4; IGETC: 4J; GAV-GE: D2

Analysis of the nature of women's and men's traditional and changing roles in society including development of women's and men's potential, relationships in marriage, influence of mass media, employment practices, legal provisions and women's and men's liberation.

4770	LEC	SS210	KREIDER R	3.20	3.0	TuTh	0230P-0350P
6191	LEC	HOL1	FAUTT M	3.30	3.0	W	0600P-0905P
Above class meets at the Hollister Briggs site							

SUMMER 2008

STUDY AND TRAVEL IN MEXICO  
JUNE 8- July 6

Attend the Orientation: Saturday, March 8 at 10 am in HU105 on the Gilroy main campus.

Earn up to 5 units. Study the language and culture while living with a host family in Zacatecas.

For more information visit [www.gavilan.edu/spanish](http://www.gavilan.edu/spanish), call David Perez at 408-848-4742 or email [dperez@gavilan.edu](mailto:dperez@gavilan.edu)

Sect. Type Room Instructor Hrs. Units Days Begin-End Footnotes

**SOC 10 Mass Media and Society**

Advisory: English 250, English 260

Transferable: CSU; UC; CSU-GE: C2, D0; IGETC: 4J; GAV-GE: C2, D2

This course helps us understand the 20th century revolution in mass media by focusing on the history, economics and social impact of the newspaper, book publishing, magazine, film, television, public relations, advertising and music industries. We will study audience, propoganda and mass communication theory; we will discuss new technology, ethnic media in the U.S., ethical issues and attempts to regulate or control the media. Honors students will complete more in-depth analysis of media issues, and will finish a media-related research project. This course is also listed as JOUR 10. This course has the option of a letter grade or credit/no credit.

4771	LEC	AR103	GUERRAZZI D	3.20	3.0	MW	0810A-0930A
------	-----	-------	-------------	------	-----	----	-------------

**SOC 21 Marriage and the Family**

Advisory: Eligible for English 250 and English 260.

Transferable: CSU; CSU-GE: E2; GAV-GE: E2

Survey of information on preparation for marriage, including dating, courtship, engagement, mate selection, adjustment and parenthood. Time will also be spent on the study of families and how they function.

4772	LEC	AL101	HINN G	3.20	3.0	TuTh	0945A-1105A
4773	LEC	BU117	KREIDER R	3.20	3.0	MW	1250P-0210P

**SPANISH**

**SPAN 1A Elementary Spanish**

Transferable: CSU; UC; CSU-GE: C2; GAV-GE: C2; CAN: SPAN 2, SPAN SEQ. A

Beginning course with emphasis on understanding and speaking Spanish; introduction to reading and writing Spanish. This course will also introduce students to Hispanic culture and institutions.

.33	L/L	HU105	MARQUES A	7.90	5.0	MTuWTh&2.3	0810A-0915A
4775	L/L	HOL5	PEREZ D	7.90	5.0	MTuWTh&2.3	0945A-1050A
Above class meets at the Hollister Briggs site							

**SPAN 1B Elementary Spanish**

Advisory: Spanish 1A or equivalent.

Transferable: CSU; UC; CSU-GE: C2; IGETC: 6A; GAV-GE: C2; CAN: SPAN 4, SPAN SEQ. A

Continuation of Spanish 1A. Further development of the four skills of understanding, speaking, reading and writing Spanish. This course will continue to emphasize the study of Hispanic culture and institutions.

4776	L/L	HOL5	PEREZ D	7.90	5.0	MTuWTh&2.3	830A-0935A
Above class meets at the Hollister Briggs site							
4777	L/L	HU105	MARQUES A	7.90	5.0	MTuWTh&2.3	1120A-1225P
4778	L/L	HU105	PEREZ D	7.90	5.0	MTuWTh&2.3	1250P-0155P

**SPAN 2B Intermediate Spanish**

Advisory: Spanish 2A or equivalent.

Transferable: CSU; UC; CSU-GE: C2; IGETC: 3B, 6A; GAV-GE: C2; CAN: SPAN 10, SPAN SEQ. B

Review of basic structures and grammar with greater emphasis on vocabulary and idioms. Introduction to literature as it reflects the characteristics of Hispanic societies. Greater emphasis on composition as a medium of expression.

4779	L/L	HU105	MARQUES A	7.90	5.0	MTuWTh&2.3	0945A-1050A
------	-----	-------	-----------	------	-----	------------	-------------

**SPAN 8A Conversational Spanish**

Transferable: CSU; GAV-GE: C2

This course is a beginning Spanish course, focusing on the Spanish sound system, basic grammar and vocabulary, and cultural elements. Although emphasis is on listening and speaking, basic reading and writing skills will be developed.

6192	LEC	HOL1	POLO I	3.30	3.0	M	0600P-0905P
Above class meets at the Hollister Briggs site							

Classroom Locations: Refer to "How to Use This Schedule" on page 6.

Sect. Type Room Instructor Hrs. Units Days Begin-End Footnotes

**SPAN 8B Conversational Spanish**

Advisory: Spanish 8A or equivalent.  
Transferable: CSU; GAV-GE: C2

This course requires knowledge of Spanish pronunciation, basic vocabulary, and present tense grammar. More advanced grammar and vocabulary, and cultural elements will be taught in the development of listening, speaking, basic reading and writing skills.

6193	LEC	HU105	POLO I	3.30	3.0	W	0600P-0905P
------	-----	-------	--------	------	-----	---	-------------

**SPAN 8C Conversational Spanish**

Advisory: Spanish 8B or equivalent.  
Transferable: CSU; GAV-GE: C2

This course requires considerable knowledge of Spanish pronunciation, vocabulary, grammar and syntax. More advanced grammar and vocabulary will be taught in the development of listening, speaking, reading and writing skills.

6194	LEC	HU105	LEMOS C	3.30	3.0	M	0630P-0935P
------	-----	-------	---------	------	-----	---	-------------

**SPAN 12B Spanish for Spanish Speakers**

Advisory: Basic Spanish speaking skills.  
Transferable: CSU; UC; CSU-GE: C2; IGETC: 6A; GAV-GE: C2, F

Continuation of 12A; through comparative analysis of selected literary works, the course develops an awareness of cultural and literary contributions from Mexico and other Spanish speaking societies. The course is taught in Spanish with emphasis on composition as a medium of expression.

4780	L/L	ONLINE	PEREZ D	8.40	5.0	DHR	0000-0000 38
------	-----	--------	---------	------	-----	-----	--------------

This online class will be delivered entirely over the internet. After enrolling, start the class by going to <http://www.gavilan.edu/disted/>, click on your class link and email the instructor at [dperez@gavilan.edu](mailto:dperez@gavilan.edu). Students who have not begun the class or contacted the instructor by 5 pm on Feb. 4 will be dropped from the class.

**SPAN 23 Independent Study**

Required: The study outline prepared by the student and the instructor must be filed with the department and the dean.  
Transferable: CSU

Designed to afford selected students specialized opportunities for exploring areas at the independent study level. The courses may involve extensive library work, research in the community, or special projects. May be repeated until six units of credit are accrued. This course has the option of a letter grade or credit/no credit.

4781	IND	HU108	PEREZ D	6.40	2.0	DHR	0000-0000 21
------	-----	-------	---------	------	-----	-----	--------------

4782	IND	HU110	MARQUESA	3.30	1.0	DHR	0000-0000
------	-----	-------	----------	------	-----	-----	-----------

Speech: see Communications

Statistics: see Mathematics

**THEATRE ARTS / TELEVISION**

**THEA 3 El Teatro Campesino**

Advisory: Eligible for English 250 and English 260.  
Transferable: CSU; UC; CSU-GE: C1; IGETC: 3A; GAV-GE: C1

Reading, viewing and discussing the work of writer/director Luis Valdez and El Teatro Campesino (The Farmworkers Theatre) is the focus of this course. It traces the historical development of the theatrical company from its creation in 1965 to the present. Students will read actos, plays and view theatrical productions performed by El Teatro Campesino. This course has the option of a letter grade or credit/no credit.

4783	ONLINE	GONZALEZ R	6.80	3.0	DHR	0000-0000 11 13
			03/13/08 - 05/23/08			This HYBRID lecture/online class will be delivered partially over the Internet. See the online syllabus for details. <a href="http://www.gavilan.edu/dusted/">http://www.gavilan.edu/dusted/</a>



**Broadcast Television**  
*Certificate of Achievement*

THEA 14	Stage Production	2 units
THEA 16	Introduction to Television	3 units
THEA 17A	Television and Video Workshop	3 units
THEA 17B	Television and Video Workshop	3 units
THEA 19	Television and Film Acting	3 units

Choose one of the following courses:

THEA 6 Introduction to Audio Production (3 units)

THEA 20 Introduction to Scriptwriting (3 units)

		3 units
Total Units for Certificate of Achievement:		17 UNITS



The **Gavilan Educational Station**  
*Be a part of the cameras, lights, action!*



**THEA 98 - GAVTV 18**

Join us!

Monday evenings for the

**Monday Night Series**

6:30 p.m.

Gavilan College Theater

**FREE!!**



Staged Readings of Scripts,  
Plays and Literature!

Presented by Gavilan Theatre Arts

Check the Theater Department Website  
for play titles and dates.



Sect. Type Room Instructor Hrs. Units Days Begin-End Footnotes

## THEA 4 Oral Reading

**Advisory:** Eligible for English 250 and English 260.  
**Transferable:** CSU; UC; CSU-GE: C1; GAV-GE: C1

An introduction to the analysis, preparation and dramatic reading of literature, including classical and contemporary prose, poetry and drama. Students prepare, analyze and orally present and interpret great works of drama and literature for an audience. This course is also listed as CMUN 2.

4784 LEC TH125 HAEHLJ 3.20 3.0 MW 1120A-1240P 25

## THEA 7 Theatre Appreciation

**Transferable:** CSU; UC; CSU-GE: C1; IGETC: 3A; GAV-GE: C1

This learning experience examines how theatre productions are staged and created. Elements of theatrical production including: writing, producing, directing, designing, and acting will be explored.

4785 LEC TH125 HAEHLJ 3.20 3.0 TuTh 0945A-1105A

## THEA 11 Dance and Movement for the Theatre

**Transferable:** CSU; UC; GAV-GE: C1

Introduction to basic dance, period movement, stage combat and mime techniques suitable for the performing arts. This course has the option of a letter grade or credit/no credit. May be repeated three times for credit.

4786 L/L TH125 WAGGONER K 3.30 2.0 TuTh 0130P-0250P

## THEA 12A Acting: History and Practice

**Transferable:** CSU; UC; CSU-GE: C1; GAV-GE: C1; CAN: DRAM 8

An introduction to the historical development of acting as a practice of human cultural expression. Students will acquire a vocabulary for theatre performance as an art form and analyze dramatic works in a historical context. Practice of basic acting concepts, character analysis, preparation and performances of monologues and scenes will be required in the course.

4787 L/L TH125 HAEHLJ 5.50 3.0 TuTh&1 1120A-0125P

## THEA 12B Acting Techniques

**Advisory:** Theatre Arts 12A.  
**Transferable:** CSU; UC; GAV-GE: C1

Techniques for creating characterizations for performance. Various acting approaches will be examined through research, discussion and acting exercises. This course has the option of a letter grade or credit/no credit. May be repeated two times for credit.

4788 L/L TH125 HAEHLJ 4.20 2.0 TuTh 1120A-0125P

## THEA 13A Actor's Workshop

**Transferable:** CSU; UC; GAV-GE: C1

Audition, rehearsal and performance of a theatrical production for public performance.

6195 LAB TH125 HAEHLJ 10.10 3.0 MTuWTh 0630P-0855P 11  
 01/30/08-05/08/08

## THEA 13B Actor's Workshop

**Transferable:** CSU; UC; GAV-GE: C1

Audition, rehearsal and performance of a theatrical production for public performance.

6196 LAB TH125 HAEHLJ 10.10 3.0 MTuWTh 0630P-0855P 11  
 01/30/08-05/08/08

Sect. Type Room Instructor Hrs. Units Days Begin-End Footnotes

## THEA 13C Actor's Workshop

**Advisory:** THEA 13B.  
**Transferable:** CSU; UC; GAV-GE: C1

Audition, rehearsal and performance of a theatrical production for public performance.

6197 LAB TH125 HAEHLJ 10.10 3.0 MTuWTh 0630P-0855P 11  
 01/30/08-05/08/08

## THEA 13D Actor's Workshop

**Advisory:** Theatre Arts 13C  
**Transferable:** CSU; UC; GAV-GE: C1

Audition, rehearsal and performance of a theatrical production for public performance.

6198 LAB TH125 HAEHLJ 10.10 3.0 MTuWTh 0630P-0855P 11  
 01/30/08-05/08/08

## THEA 14 Stage Production

**Advisory:** Eligible for English 250 and English 260.  
**Transferable:** CSU; UC; GAV-GE: C1

An individualized course in technical theatre production for the performing arts. Areas of study include: scenery, lighting, props, costumes, sound, make-up, public relations/box office management or stage management. May be repeated until a maximum of 9 units are accrued.

4789 LAB TH125 KLIPSTINE W 3.30 1.0 MW 1250P-0210P

4790 LAB TH125 KLIPSTINE W 6.40 2.0 MW 1250P-0355P

4791 LAB TH125 KLIPSTINE W 10.10 3.0 MW&6.7 1250P-0355P

## THEA 16 Television History and Practice

**Advisory:** Eligible for English 250 and 260.  
**Transferable:** CSU; GAV-GE: C1

A history of the development of television technology and programming as a mass communications tool. Students study various approaches and methods in writing, programming and producing for television.

4792 LEC LI144 ABAD M 3.20 3.0 MW&2.3 1120A-1240P

## THEA 17A Television and Video Workshop

**Advisory:** Theatre Arts 16 Intro to TV or consent of instructor.  
**Transferable:** CSU; GAV-GE: C1

An introduction to television and video technology, including pre-production, production and post-production techniques such as: camera work, studio equipment, lighting, audio plus off-line and on-line editing.

4793 L/L LI144 FRAZIER J 5.50 3.0 TuTh 1250P-0315P

## THEA 17B Television and Video Workshop

**Advisory:** Completion of Theatre Arts 17A.  
**Transferable:** CSU; GAV-GE: C1

Emphasis placed on production and post-production techniques in video production. Student knowledge and skills are increased by participating in live to tape projects. May be repeated twice for credit.

4794 LEC LI144 FRAZIER J 5.50 3.0 TuTh 1250P-0315P

## Be Aware

You MAY NOT take courses that overlap (courses that meet at the same day and time)!

## TBA

means that the class has a flexible schedule. For details, contact the instructor.

**Classroom Locations: Refer to "How to Use This Schedule" on page 6.**

Sect. Type Room Instructor Hrs. Units Days Begin-End Footnotes

**THEA 19 Television and Film Acting**

Transferable: CSU; UC; GAV-GE: C1

Theory and practice of acting for film and television. Students will learn basic performance techniques for the camera. Learning experiences include projects in broadcasting, reporting, commercials, public service announcements (psa), comedy and drama. This course has the option of a letter grade or credit/no credit. May be repeated three times for credit.

4795 L/L LI144 ABAD M 5.50 3.0 TuTh&2.3 1120A-1240P

**THEA 20 Introduction to Scriptwriting**

Advisory: English 250

Transferable: CSU; CSU-GE: C1

An introductory course on script development, writing and formatting for broadcast television and film production. This course has the option of a letter grade or credit/no credit. May be repeated three times for credit.

4796 ONLINE GONZALEZ R 6.80 3.0 DHR 0000-0000 11 38

03/13/08 - 05/23/08 This online class will be delivered entirely over the internet. After enrolling, start the class by going to <http://www.gavilan.edu/disted/>, click on your class link and email the instructor at [rgonzalez@gavilan.edu](mailto:rgonzalez@gavilan.edu). Students who have not begun the class or contacted the instructor by 5 pm on March 15 will be dropped from the class.



**THEA 22 Field Work and Service**

Required: Learning contracts must be filled out and signed by the student and the supervising instructor.

Transferable: CSU

Supervised field work within the college and with local agencies. Students serve in useful group activities in leadership roles prescribed for them by faculty or community agencies. A maximum of six units may be completed. This is a credit/no credit course.

4797 FEX TH125 ABAD M 3.30 1.0 DHR 0000-0000 21

**THEA 23 Independent Study**

Required: The study outline prepared by the student and the instructor must be filed with the department and the dean.

Transferable: CSU

Designed to afford selected students specialized opportunities for exploring areas at the independent study level. The courses may involve extensive library work, research in the community, or special projects. May be repeated until six units of credit are accrued. This course has the option of a letter grade or credit/no credit.

4798 IND TH125 ABAD M 3.30 1.0 DHR 0000-0000 22

4799 IND TH125 ABAD M 6.40 2.0 DHR 0000-0000 22

4800 IND TH125 FRAZIER J 3.30 1.0 DHR 0000-0000 22

4801 IND TH125 FRAZIER J 6.40 2.0 DHR 0000-0000 22

4802 IND TH125 HAEHL J 3.30 1.0 DHR 0000-0000 22

4803 IND TH125 HAEHL J 6.40 2.0 DHR 0000-0000 22

**THEA 98 Special Topics - GavTV - Channel 18**

Transferable: CSU

Special topics courses examine current problems or issues of interest to students within a specific discipline area. For topical content information, consult with the appropriate department chairperson. For transfer status, check with a counselor. This course may have the option of a letter grade or credit/no credit.

4804 LEC OE003 ABAD M 1.00 1.0 Tu 1110A-1200P

4805 LEC OE003 ABAD M 2.30 2.0 Tu 1110A-1200P



See live Theatrical productions at the Playhouse in San Juan Bautista!

Instructor: Marilyn Abad-Cardinalli

March 10 - May 23

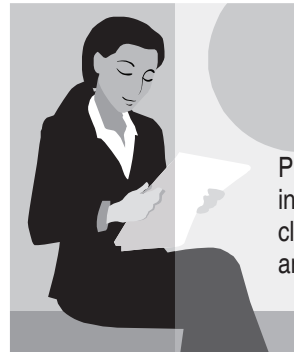

also listed as CMUN 2

**THEA 4 3 units Oral Reading**

Instructor: Dr. John Lawton-Haehl

Prepare, analyze and orally present and interpret great works of drama including classical and contemporary prose, poetry and drama and literature for an audience!

Satisfies the Arts requirement (Area C-1) of the GE-CSU and the Gavilan AA/AS Degree. Use as a UC elective.

Enter the world of live entertainment!!!

**THEA 12A Acting: History & Practice**



**THEA 12B Acting Techniques**

Gain self-confidence through theatre and acting!

THEA 12A satisfies the Arts requirement (Area C-1) of the GE-CSU and the Gavilan AA/AS Degree. Use either as UC electives.



**THEA 13 A-D Actor's Workshop presents**

**A Midsummer Night's Dream**

by William Shakespeare

A romantic comedy for all ages.

Artistic Direction by John Lawton Haehl

For more information email [jlawtonhaehl@gavilan.edu](mailto:jlawtonhaehl@gavilan.edu)

Transfer to: CSU; UC; GAV-CE: C1

Sect. Type Room Instructor Hrs. Units Days Begin-End Footnotes

**VOCATIONAL PREP STUDENTS: DISABILITY**

**AE 600 Vocational Training I**

Transferable: No

Prevocational skills for adults with impaired cognitive functioning. Entry level work preparation is emphasized. Skills taught include basic work routine orientation, communication skills, job ability assessment, and self-management skills.

4013	LAB	LI204	FRANKLIN L	33.80	.0	DHR	0000-0000	31 75
4014	LAB	HOPE-G	MERRILL BROWN C SATOK	33.80	.0	DHR	0000-0000	31 63 75
See Footnote: Above class meets Off Campus								
4015	LAB	HOPE-H	BROWN C SATOK	33.80	.0	DHR	0000-0000	31 51 75
See Footnote: Above class meets Off Campus								
4016	LAB	LI171	SATOK	2.00	.0	TuTh	0910A-1000A	31 75
4017	LAB	LI117	MERRILL BROWN C	7.00	.0	W	0910A-0400P	31 75
4018	LAB	MHG3	MERRILL	4.00	.0	M	0945A-1250P	31
4019	LAB	GY131G	SATOK	2.00	.0	TuTh	1010A-1110A	31 75
4020	LAB	APE120 APE121	BROWN C BROWN C	2.00	.0	TuTh	1120A-1240P	31 75

**AE 602 Vocational Training III**

Transferable: No

Practical training and on-the-job work experience for students with disabilities. This course also provides preparation for entry level employment utilizing a number of work alternatives and settings.

4021	LAB	HOPE-H	SATOK	33.80	.0	DHR	0000-0000	31 51 75
See Footnote: Above class meets Off Campus								
4022	LAB	LI204	FRANKLIN L	33.80	.0	DHR	0000-0000	31 75
4023	LAB	HOPE-G	BROWN C MERRILL	33.80	.0	DHR	0000-0000	31 63 75
See Footnote: Above class meets Off Campus								

**AE 603 Vocational Training IV**

Transferable: No

AE 603 is a job readiness course which provides opportunities for individuals with disabilities to participate in service-learning activities and job readiness training leading to job development and placement in a community setting.

4026	L/L	LI204	FRANKLIN L	3.40	.0	W	0945A-1250P	31 75
4027	L/L	MHG8	MERRILL	3.40	.0	F	0945A-1250P	
Above class meets at Morgan Hill Community site								

**AE 605 Vocational Training VI**

Transferable: No

This course is designed for students with disabilities. The purpose of this course is to improve the student's ability to participate in the community, by increasing independence through acquisition of survival vocabulary, structured practice in functional reading utilizing phonics and content recognition, and increased enjoyment in reading for pleasure. Opportunities will be provided for oral reading of high interest-low reading level life experience stories written or revised specifically for adults with limited reading skills.

4028	L/L	BU117	BROWN C	1.50	.0	Th	1250P-0210P	31 75
------	-----	-------	---------	------	----	----	-------------	-------

**AE 613 Independence Training IV**

Transferable: No

This course is designed for students with disabilities. The purpose of this course is to improve the student's ability to build math competencies related to independence in daily living and the work site. The focus of the class is basic computation, consumer awareness, money management, banking and purchasing.

4029	L/L	BU117	BROWN C	1.50	.0	Tu	1250P-0210P	31 75
------	-----	-------	---------	------	----	----	-------------	-------

Sect. Type Room Instructor Hrs. Units Days Begin-End Footnotes

**AE 636 Adapted Physical Education**

Advisory: Students must be able to document a physical disability.

Transferable: No

An individualized program of adapted physical education activities designed to meet the needs of students who are physically limited or disabled. The course assists in the development and appreciation of physical activity as a regular planned contribution to one's overall well-being. This course is for the non-matriculating student, is not graded and is without college credit.

4030	LAB	GY100P	ELLIS D	3.40	.0	DHR	0000-0000	31 75 90
4031	LAB	LOADCS	CRETIN A	3.40	.0	MW	0945A-1105A	70 31 75
See Footnote: Above class meets Off Campus								
4032	LAB	LOADCS	CRETIN A	3.40	.0	TuTh	0945A-1105A	70 31 75
See Footnote: Above class meets Off Campus								
4033	LAB	LOADCS	MARINGER J	1.00	.0	F	0945A-1105A	70 31 75
See Footnote: Above class meets Off Campus								
4034	LAB	APE101	ELLIS D	3.30	.0	F	0945A-1250P	
4035	LAB	HOLLCC	CRETIN A	3.40	.0	MW	1120A-1240P	68 31 75
See Footnote: Above class meets Off Campus								

**Word Processing: see CSIS**

**WORK EXPERIENCE**

**CWE 190 Occupational Work Experience**

Required: Declared vocational major. Concurrent enrollment in seven or more units (including CWE units, except for summer school. For summer school, enrollment in one other class is required). Minimum 2.00 G.P.A.

Transferable: CSU

Occupational work experience for students who have a job related to their major. A training plan is developed cooperatively between the employer, college and student. (CR/NC grading) 75 hours per semester paid work = 1 unit. 60 hours non-paid (volunteer) work per semester = 1 unit. May be taken for a maximum total of 16 units.

4279	WEX	BU125	KERR L	5.30	1.0	TBA	0000-0000	16
4280	WEX	BU125	KERR L	10.60	2.0	TBA	0000-0000	16
4281	WEX	BU125	KERR L	15.90	3.0	TBA	0000-0000	16
4282	WEX	BU125	KERR L	21.20	4.0	TBA	0000-0000	16

**CWE 192 General Work Experience Education**

Required: Concurrent enrollment in seven or more units (including CWE units, except for summer school. For summer school, enrollment in one other class is required) Minimum 2.00 G.P.A.

Transferable: CSU

General work experience for students who have a job unrelated to their major. General work experience is supervised employment which is intended to assist students in acquiring desirable work habits, attitudes and career awareness. A training plan is developed cooperatively between the employer, college and student. (CR/NC grading) 75 hours per semester paid work = 1 unit. 60 hours non-paid (volunteer) work per semester = 1 unit. May be taken for a maximum of 16 units.

4283	WEX	BU125	KERR L	3.30	1.0	TBA	0000-0000	16
See Footnote: Above class meets Off Campus								
4284	WEX	BU125	KERR L	6.40	2.0	TBA	0000-0000	16
See Footnote: Above class meets Off Campus								
4285	WEX	BU125	KERR L	9.50	3.0	TBA	0000-0000	16
See Footnote: Above class meets Off Campus								

Classroom Locations: Refer to "How to Use This Schedule" on page 6.