

Choose a **THEME** for your English class:

Find the number, by the course section number, that corresponds to a theme below.



- 1 Explore consumerism and wild alternatives.
- 2 Explore the great American classics.
- 3 Explore a little basic science and technology on the way to making you a competent, college-level writer.
- 4 Explore the great literature of the human condition, challenging you to respond to literary art, science fiction, music, tragedy and the joy of life and living.
- 5 Focus on defying social norms.
- 6 Focus on the environment, including where we live and what we eat.

- 7 Develop your understanding of our multicultural society through literature.
- 8 Play with learning: Understand how kids grow through reading and writing.
- 9 Focus on issues of childhood, growing up too fast, and the blurred line between the roles of adult/child.
- 10 Take a nature walk through the literature of the American West.
- 11 Take a journey into Southern literature.
- 12 Speak up and speak out: Develop your voice at home, at school, and in the world.
- 13 First Year Experience: Focus on bridging worlds and navigating frontiers.
- 14 Puente: Focus on Mexican American/Latino literature.
- 15 Learn to be a skeptic, ask questions, believe nothing for granted and have the courage of your convictions. Not for those convinced that all life's answers lie in the paranormal and supernatural.

ENGLISH

ENGL 1A Composition

Prerequisite: English 250 and English 260 or English 250 and SSCI 270A or English 250 and SSCI 270B with a grade of 'C' or better or satisfactory score on the English placement examination.

Transferable: CSU; UC; CSU-GE: A2; IGETC: 1A; GAV-GE: A2; CAN: ENGL 2, ENGL SEQ. A

This is a writing course which emphasizes expository writing, argumentative writing, and critical reading of expository prose. It is meant to train students in clear thinking and reasoned support of ideas. Students will be given the opportunity to read models of good expository and argumentative prose and learn the techniques of good writing. These include choosing appropriate subjects, developing restricted, unified, and precise theses and presenting supporting evidence in a logical, lucid, and effective manner. To achieve this end, students write no fewer than six essays and read at least five works, two of which are book length.

LEARNING COMMUNITY SECTION:

- 14 4305 LEC HU103 CANDELARIA X 3.40 3.0 TuTh 0945A-1110A 182
The above class is part of a Puente learning community. You must enroll in ALL corequisite courses. See the ENGLISH - PUENTE (below)

OTHER SECTIONS:

4301 LEC	MHG4	JAMES R	3.40	3.0	TuTh	0810A-0935A	1
Above class meets at Morgan Hill Community site							
2 4302 LEC	CJ500	LUOMA D	3.40	3.0	TuTh	0810A-0935A	1
3 4303 LEC	HU103	SANDLER S	3.40	3.0	F	0810A-1120A	1
4 4304 LEC	HU103	SANDLER S	3.40	3.0	MW	0945A-1110A	1
5 4306 LEC	HOL4	SALVIN C	3.40	3.0	TuTh	0945A-1110A	1
Above class meets at the Hollister Briggs site							
4307 LEC	HU103	WISDOM K	3.40	3.0	MW	1120A-1245P	1
4308 LEC	CJ500	CONDON D	3.40	3.0	TuTh	1120A-1245P	1
4309 LEC	CJ500	LAU D	3.40	3.0	MW	1255P-0220P	1
4310 LEC	HU102	JACKSON S	3.40	3.0	TuTh	1255P-0220P	1
4311 LEC	HU103	STAFF	3.40	3.0	MW	0230P-0355P	1
4312 LEC	HU102	JACKSON S	3.40	3.0	TuTh	0400P-0525P	1
10 4313	ONLINE	HESSE D	3.40	3.0	DHR	0000-0000	1
This online class will be delivered entirely over the internet. After enrolling, start the class by going to http://www.gavilan.edu/disted/ , click on your class link, and email the instructor at hdesse@gavilan.edu . Students who have not begun the class or contacted the instructor by 5 pm on Monday, February 5 will be dropped from the class.							
4314	ONLINE	CHAFFIN C	3.40	3.0	DHR	0000-0000	1
This online class will be delivered entirely over the internet. After enrolling, start the class by going to http://www.gavilan.edu/disted/ , click on your class link, and email the instructor at cchaffin@gavilan.edu . Students who have not begun the class or contacted the instructor by 5 pm on Monday, February 5 will be dropped from the class.							
6091 LEC	HU102	KOVACS M	3.40	3.0	S	0900A-1210P	1
3 6092 LEC	HU103	BRETT T	3.40	3.0	M	0630P-0940P	1
6093 LEC	HOL6	PARKER V	3.40	3.0	Tu	0630P-0940P	1
Above class meets at the Hollister Briggs site							
6094 LEC	MHG3	JACKSON J	3.40	3.0	Th	0630P-0940P	1
Above class meets at Morgan Hill Community site							

ENGL 1B Composition and Literature

Prerequisite: English 1A with a grade of "C" or better.

Transferable: CSU; UC; CSU-GE: C ; IGETC: 3B; GAV-GE: C2; CAN: ENGL 4, ENGL SEQ. A

English 1B continues the work begun in 1A, but now the emphasis shifts to writing expository prose in conjunction with reading and analyzing imaginative literature. Students are to write as fledgling critics and use the text as a basis for other forms of reflection. The reading requirement includes short stories, poetry, drama, and at least two novels. Course work will also include fundamentals of research writing.

4315 LEC	MHG10	JAMES R	3.40	3.0	MW	0810A-0935A	1
Above class meets at Morgan Hill Community site							
2 4316 LEC	HU102	LUOMA D	3.40	3.0	F	0810A-1120A	1
4317 LEC	HU102	RICHARDS G	3.40	3.0	MW	0945A-1110A	1
2 4318 LEC	CJ500	LUOMA D	3.40	3.0	TuTh	0945A-1110A	1
4319 LEC	CH102	RICHARDS G	3.40	3.0	TuTh	1120A-1245P	1
1 4320 LEC	HU102	JACKSON S	3.40	3.0	TuTh	0230P-0355P	1
4321	ONLINE	WISDOM K	3.40	3.0	DHR	0000-0000	1
This online class will be delivered entirely over the internet. After enrolling, start the class by going to http://www.gavilan.edu/disted/ , click on your class link, and email the instructor at kwisdom@gavilan.edu . Students who have not begun the class or contacted the instructor by 5 pm on Monday, February 5 will be dropped from the class.							
4322	ONLINE	WARREN K	3.40	3.0	DHR	0000-0000	1
This online class will be delivered entirely over the internet. After enrolling, start the class by going to http://www.gavilan.edu/disted/ , click on your class link, and email the instructor at kwarren@gavilan.edu . Students who have not begun the class or contacted the instructor by 5 pm on Monday, February 5 will be dropped from the class.							
4 6095 LEC	HU102	BRETT T	3.40	3.0	Th	0630P-0940P	1



ENGLISH - PUENTE

The Puente Project is a two-semester program that combines three components: writing, counseling and mentoring to support students to transfer to four-year universities and colleges. The Guidance 1 course focuses on self-assessment and career development. The English 1A course focuses on Mexican American/Latino literature. The program is open to all eligible students. For more information, call Celia Marquez, Puente Co-Coordinator at 408-848-4807.

ENGL 1A Composition

4305 LEC HU103 CANDELARIA X 3.40 3.0 TuTh 0945A-1110A 18 82

GUID 1 Self Assessment and Career Development

4419 LEC CH102 MARQUEZ C 2.30 2.0 M 1120A-1220P 50 82 89
W 1120A-1225P

Sect. Type Room Instructor Hrs. Units Days Begin-End Footnotes

ENGL 1C Critical Reasoning and Writing

Prerequisite: English 1A with a grade of "C" or better.
Transferable: CSU; UC; CSU-GE: A3; IGETC: 1B; GAV-GE: C2

This course is designed to develop critical thinking, reading, and writing skills beyond the level achieved in English 1A. The emphasis is on critical analysis of arguments and the development of the ability to integrate the principles of critical thinking into essay writing.

4323	LEC	HU102	WISDOM K	3.40	3.0	MW	0810A-0935A	1
4324	LEC	HOL5	VILLARREAL A	3.40	3.0	TuTh	0945A-1110A	1
Above class meets at the Hollister Briggs site								
4325	LEC	CJ500	CONDON D	3.40	3.0	TuTh	1255P-0220P	1
4326	LEC	CJ500	LAU D	3.40	3.0	MW	0230P-0355P	1
4327	LEC	HU103	SOLTIS M	3.40	3.0	TuTh	0400P-0525P	1
4328	ONLINE	CANDELARIA X		3.40	3.0	DHR	0000-0000	1
This online class will be delivered entirely over the internet. After enrolling, start the class by going to http://www.gavilan.edu/disted/ , click on your class link, and email the instructor at xcandelaria@gavilan.edu . Students who have not begun the class or contacted the instructor by 5 pm on Monday, February 5 will be dropped from the class.								
6096	LEC	HU103	BRETT T	3.40	3.0	W	0630P-0940P	1



ENGL 2C Introduction to Film and Fiction

Prerequisite: Eligible for English 1A.
Transferable: CSU; UC; CSU-GE: C2; IGETC: 3B; GAV-GE: C2

This is a literature course in analysis of the novel and film as art forms. The student will read several novels, view the films based on the novels, and discuss the difference in techniques, both orally and in writing.

6097	LEC	SS214	RICHARDS G	3.40	3.0	W	0630P-0940P	
------	-----	-------	------------	------	-----	---	-------------	--



ENGL 2J Mythology

Prerequisite: Eligible for English 1A.
Transferable: CSU; UC; CSU-GE: C2; IGETC: 3B; GAV-GE: C2

This course is a survey of myths from around the world, with an emphasis on literary analysis of the myths. The course covers the purposes and types of myths; the development of myths and mythological characters, the recurring elements of mythological structures, the influence of mythology on contemporary texts.

4329	LEC	SS111	CANDELARIA X	3.40	3.0	TuTh	1120A-1245P	
------	-----	-------	--------------	------	-----	------	-------------	--

ENGL 4B British Literature - 1798 to Present

Prerequisite: Eligible for English 1A.
Transferable: CSU; UC; CSU-GE: C2; IGETC: 3B; GAV-GE: C2; CAN: ENGL 10, ENGL SEQ. B

This course is a study of the masters of British literature, covering writers such as Wordsworth, Coleridge, Shelly, Keats, Tennyson, Browning, Bronte, Hardy, Hopkins, Yeats, Woolf, Joyce, Lawrence, Eliot, and Lessing. English 4B covers 1798 A.D. to the present. Note: This course need not be taken in sequence.

4330	ONLINE	JAMES R		3.40	3.0	DHR	0000-0000	38
This online class will be delivered entirely over the internet. After enrolling, start the class by going to http://www.gavilan.edu/disted/ , click on your class link, and email the instructor at rjames@gavilan.edu . Students who have not begun the class or contacted the instructor by 5 pm on Monday, February 5 will be dropped from the class.								



Instructor - Grant Richards

- The DaVinci Code*
- Pride and Prejudice*
- Million Dollar Baby*
- Mystic River*
- A History of Violence*
- Cold Mountain*
- Sideways*
- Motorcycle Diaries*
- Closer*
- Fight Club*
- Notebook*
- High Fidelity*
- The Shawshank Redemption*
- To Kill a Mockingbird*
- One Flew Over the Cuckoo's Nest*
- Chocolat*
- LA Confidential*
- Get Shorty and more!*

This class can fulfill your IGETC humanities transfer requirement.



ENGL 2J Mythology

Instructor: Xochi Candelaria

This course offers an exploration of the major figures and themes of Greek, Aztec and African mythologies.

Transferable to UC and CSU. Satisfies the Humanities requirement under both the CSU and IGETC GE patterns.



This class can fulfill your IGETC humanities transfer requirement.

ENGL 4B

British Literature 1789 to Present

Instructor: Robert James

Now offered Online

Have you met the prerequisite?
It's required!

Footnotes contain valuable information pertaining to your class selection. Footnotes follow class listings.

Sect. Type Room Instructor Hrs. Units Days Begin-End Footnotes

ENGL 9A Introduction to Creative Writing

Prerequisite: Eligible for English 1A.

Transferable: CSU; UC; CSU-GE: C2; GAV-GE: C2; CAN: ENGL 6

This course includes the writing, reading, and critical discussions of various forms of poetry and fiction.

4331	LEC	SS111	SANDLERS	3.40	3.0	MW	1120A-1245P
6098	LEC	HU102	CANDELARIA X	3.40	3.0	W	0530P-0840P

ENGL 9B Advanced Creative Writing

Prerequisite: English 9A with a grade of credit or C or better.

Transferable: CSU; UC; CSU-GE: C2; GAV-GE: C2

This class is a continuation of English 9A, with the emphasis shifting to publication. The genre of non-fiction will be the primary focus, but the genres of fiction will also be taught at a more comprehensive level than in English 9A. The process of finding a market for one's work will be followed step by step. The class may compile and publish "Soaring", Gavilan's literary magazine, each spring semester.

4332	LEC	SS111	SANDLERS	3.40	3.0	MW	1120A-1245P
6099	LEC	HU102	CANDELARIA X	3.40	3.0	W	0530P-0840P

ENGL 9C Poetry Writing

Prerequisite: English 9A with a grade or credit or C or better.

Transferable: CSU; UC; CSU-GE: C2; GAV-GE: C2

This course includes the writing, reading, and critical discussions of various forms of poetry.

4333	LEC	SS111	SANDLERS	3.40	3.0	MW	1120A-1245P
6100	LEC	HU102	CANDELARIA X	3.40	3.0	W	0530P-0840P

ENGL 12A Tutoring Writers: Training, Theory & Practice

Advisory: Eligible for English 1A.

Transferable: CSU

Fundamentals of compositional theory, the writing process, peer-to-peer communication, interacting with faculty and educational institutions and effective responses to writing will be covered. In addition, students will gain an understanding of the basic history, methodology and practice of writing pedagogy while developing a writing community that aids in connecting them to their own writing practice.

4334	LEC	LI120	SMITH K	1.00	1.0	Th	0230P-0400P 13
4335	LEC	LI120	SMITH K	2.30	2.0	Th	0230P-0435P 13

Sect. Type Room Instructor Hrs. Units Days Begin-End Footnotes

ENGL 12B Tutoring Writers: Training, Theory & Practice

Advisory: Eligible for English 1A.

Transferable: CSU

Fundamentals of compositional theory, the writing process, peer-to-peer communication, interacting with faculty and educational institutions and effective responses to writing will be covered. In addition, students will gain an understanding of the basic history, methodology and practice of writing pedagogy while developing a writing community that aids in connecting them to their own writing practice.

4336	LEC	LI120	SMITH K	1.00	1.0	Th	0230P-0400P
4337	LEC	LI120	SMITH K	2.30	2.0	Th	0230P-0435P

ENGL 12C Tutoring Writers: Training, Theory & Practice

Advisory: Eligible for English 1A.

Transferable: CSU

Fundamentals of compositional theory, the writing process, peer-to-peer communication, interacting with faculty and educational institutions and effective responses to writing will be covered. In addition, students will gain an understanding of the basic history, methodology and practice of writing pedagogy while developing a writing community that aids in connecting them to their own writing practice.

4338	LEC	LI120	SMITH K	1.00	1.0	Th	0230P-0400P
4339	LEC	LI120	SMITH K	2.30	2.0	Th	0230P-0435P

ENGL 23 Independent Study

Required: The study outline prepared by the student and the instructor must be filed with the department and the dean.

Transferable: CSU

Designed to afford selected students specialized opportunities for exploring areas at the independent study level. The courses may involve extensive library work, research in the community, or special projects. May be repeated until six units of credit are accrued. This course has the option of a letter grade or credit/no credit.

4340	IND	HU111	RICHARDS G	3.40	1.0	DHR	0000-0000 22
4341	IND	HU112	CANDELARIA X	6.40	2.0	DHR	0000-0000 22
4342	IND	LI202	CROOK E	6.40	2.0	DHR	0000-0000 22
4343	IND	SS103	SALVIN C	6.40	2.0	DHR	0000-0000 22
4344	IND	SS109	WARREN K	3.40	1.0	DHR	0000-0000 22
4347	IND	LI120	SMITH K	6.40	2.0	DHR	0000-0000 22



Instructor: Xochiquezta Candelaria was raised in San Juan Bautista, CA and holds degrees from UC Berkeley and New York University. Her work has appeared in *The Nation*, *New England Review*, *Gulf Coast*, and other magazines.



Instructor: Scott Sandler is from Los Angeles, where he was managing editor of the *Northridge Review* for three years. He received his M.A. in English with a creative writing emphasis from the University of Southern Mississippi. Scott's work has been published in the *Santa Monica Review*, *Product*, and other magazines.

English 9A, B, C

CREATIVE
Writing

This class fulfills your CSU humanities transfer requirement.

Sect. Type Room Instructor Hrs. Units Days Begin-End Footnotes

ENGL 250 Practical Writing

Prerequisite: English 440 or ESL 563 with a grade of 'C' or better or satisfactory score on the English placement examination.
Transferable: No; GAV-GE: A2

This course covers writing clear, correct, effective essays and learning preliminary research skills.

1
2
3 Your ENGL 250 class has a theme. See list on page 84.

LEARNING COMMUNITY SECTIONS Require co-requisites of English CD 2 or PSYC 2 - see ad on page 71:

3	4360	L/L	HU102 LI171	CROOK E CROOK E	4.40 3.0	MW Tu	1255P-0220P 1255P-0155P	1 18 36
3	4361	L/L	HU102 LI171	CROOK E CROOK E	4.40 3.0	MW Th	1255P-0220P 1255P-0155P	1 18 36
3	4903	L/L	HU102 LI171	CROOK E CROOK E	4.40 3.0	MW Tu	1255P-0220P 1255P-0155P	1 18 36
3	4904	L/L	HU102 LI171	CROOK E CROOK E	4.40 3.0	MW Th	1255P-0220P 1255P-0155P	1 18 36

FIRST YEAR EXPERIENCE SECTIONS Require co-requisites of English 260 & GUID 1. See ad:

1B	4358	L/L	HU102 SS111	HULL K HULL K	4.40 3.0	TuTh Tu	1120A-1245P 0835A-0935A	1 18 78
1B	4359	L/L	HU102 SS111	HULL K HULL K	4.40 3.0	TuTh Th	1120A-1245P 0835A-0935A	1 18 78
1B	4362	L/L	HU103 SS111	HULL K HULL K	4.40 3.0	TuTh F	1255P-0220P 0920A-1020P	1 18 78
1B	4363	L/L	HU103 SS111	HULL K HULL K	4.40 3.0	TuTh F	1255P-0220P 1030A-1130A	1 18 78

OTHER SECTIONS:

5	4348	L/L	SS203 LI171	GATEWOOD J GATEWOOD J	4.40 3.0	MW F	0810A-0935A 0810A-0910A	1 18
5	4349	L/L	SS203 LI171	GATEWOOD J GATEWOOD J	4.40 3.0	MW F	0810A-0935A 0920A-1020A	1 18
1	4350	L/L	HOL4	SALVIN C SALVIN C	4.40 3.0	MW M	0945A-1110A 1115A-1215P	1 18

Above class meets at the Hollister Briggs site.

1	4351	L/L	HOL4	SALVIN C SALVIN C	4.40 3.0	MW W	0945A-1110A 1115A-1215P	1 18
---	------	-----	------	----------------------	----------	---------	----------------------------	------

Above class meets at the Hollister Briggs site.

	4352	L/L	SS203 LI120	CAMOZZI A CAMOZZI A	4.40 3.0	TuTh Tu	0945A-1110A 0835A-0935A	1 18
--	------	-----	----------------	------------------------	----------	------------	----------------------------	------

	4353	L/L	SS203 LI120	CAMOZZI A CAMOZZI A	4.40 3.0	TuTh Th	0945A-1110A 0835A-0935A	1 18
--	------	-----	----------------	------------------------	----------	------------	----------------------------	------

5	4354	L/L	SS203 LI171	GATEWOOD J GATEWOOD J	4.40 3.0	MW F	1120A-1245P 1030A-1130A	1 18
---	------	-----	----------------	--------------------------	----------	---------	----------------------------	------

5	4355	L/L	SS203 LI171	GATEWOOD J GATEWOOD J	4.40 3.0	MW F	1120A-1245P 1140A-1240P	1 18
---	------	-----	----------------	--------------------------	----------	---------	----------------------------	------

	4356	L/L	MHG11 MHG4	STAFF STAFF	4.40 3.0	MW M	1120A-1245P 1255P-0155P	1 18
--	------	-----	---------------	----------------	----------	---------	----------------------------	------

Above class meets at Morgan Hill Community site.

	4357	L/L	MHG11 MHG4	STAFF STAFF	4.40 3.0	MW W	1120A-1245P 1255P-0155P	1 18
--	------	-----	---------------	----------------	----------	---------	----------------------------	------

Above class meets at Morgan Hill Community site.

	4364	L/L	SS203 LI171	CAMOZZI A CAMOZZI A	4.40 3.0	TuTh Tu	1255P-0220P 0230P-0330P	1 18
--	------	-----	----------------	------------------------	----------	------------	----------------------------	------

	4365	L/L	SS203 LI171	CAMOZZI A CAMOZZI A	4.40 3.0	TuTh Th	1255P-0220P 0230P-0330P	1 18
--	------	-----	----------------	------------------------	----------	------------	----------------------------	------

7	4366	L/L	SS203 LI171	STAFF STAFF	4.40 3.0	MW M	0400P-0525P 0245P-0345P	1 18
---	------	-----	----------------	----------------	----------	---------	----------------------------	------

7	4367	L/L	SS203 LI171	STAFF STAFF	4.40 3.0	MW W	0400P-0525P 0245P-0345P	1 18
---	------	-----	----------------	----------------	----------	---------	----------------------------	------

	6101	L/L	HOL6	PARKER V	4.40 3.0	Th	0530P-0940P	1 18
--	------	-----	------	----------	----------	----	-------------	------

Above class meets at the Hollister Briggs site

	6102	L/L	SS203	GRAY J	4.40 3.0	M W	0700P-0905P	1 18 48
--	------	-----	-------	--------	----------	-----	-------------	---------



Is this your first year at Gavilan? Looking for a community of people like you? Then this learning community program is specially designed for you. The first year of college can be challenging for many students. By studying and working together with your classmates and instructors, in this program you'll develop a strong network of support to help you succeed. You'll improve your reading and writing skills and also explore options for majors, transferring, and careers. Building a strong foundation in your first year will put you on the road to success throughout your college experience.

The Program: Students will take reading, writing and guidance together because these skills are needed to succeed in college classes.

Bridging Worlds and Navigating Frontiers is this semester's theme.

The following classes are part of a First Year Experience learning community. You must enroll in all three courses.

ENGL 260	Preparation for College Reading	4370 LEC	HU102	HOOPER J	3.40 3.0	TuTh	0945A-1110A	1 73
-----------------	--	----------	-------	----------	----------	------	-------------	------

ENGL 250	Practical Writing	4358 L/L	HU102 SS111	HULL K HULL K	4.40 3.0	TuTh Tu	1120A-1245P 0835A-0935A	1 18 78
-----------------	--------------------------	----------	----------------	------------------	----------	------------	----------------------------	---------

GUID 1	Self-Assessment and Career Development	4420 LEC	SC154N	WHITNEY C	2.30 2.0	W	1120A-0125P	85 89
---------------	---	----------	--------	-----------	----------	---	-------------	-------

_____ or _____

ENGL 260	Preparation for College Reading	4371 LEC	HU102	HOOPER J	3.40 3.0	TuTh	0945A-1110A	1 73
-----------------	--	----------	-------	----------	----------	------	-------------	------

ENGL 250	Practical Writing	4359 L/L	HU102 SS111	HULL K HULL K	4.40 3.0	TuTh Th	1120A-1245P 0835A-0935A	1 18 78
-----------------	--------------------------	----------	----------------	------------------	----------	------------	----------------------------	---------

GUID 1	Self-Assessment and Career Development	4421 LEC	SC154N	WHITNEY C	2.30 2.0	W	1120A-0125P	85 89
---------------	---	----------	--------	-----------	----------	---	-------------	-------

_____ or _____

ENGL 260	Preparation for College Reading	4373 LEC	HU103	HOOPER J	3.40 3.0	TuTh	1120A-1245P	1 73
-----------------	--	----------	-------	----------	----------	------	-------------	------

ENGL 250	Practical Writing	4362 L/L	HU103 SS111	HULL K HULL K	4.40 3.0	TuTh F	1255P-0220P 0920A-1020P	1 18 78
-----------------	--------------------------	----------	----------------	------------------	----------	-----------	----------------------------	---------

GUID 1	Self-Assessment and Career Development	4422 LEC	SS205	WHITNEY C	2.30 2.0	F	1140A-0145P	85 89
---------------	---	----------	-------	-----------	----------	---	-------------	-------

_____ or _____

ENGL 260	Preparation for College Reading	4374 LEC	HU103	HOOPER J	3.40 3.0	TuTh	1120A-1245P	1 73
-----------------	--	----------	-------	----------	----------	------	-------------	------

ENGL 250	Practical Writing	4363 L/L	HU103 SS111	HULL K HULL K	4.40 3.0	TuTh F	1255P-0220P 1030A-1130A	1 18 78
-----------------	--------------------------	----------	----------------	------------------	----------	-----------	----------------------------	---------

GUID 1	Self-Assessment and Career Development	4423 LEC	SS205	WHITNEY C	2.30 2.0	F	1140A-0145P	85 89
---------------	---	----------	-------	-----------	----------	---	-------------	-------

Sect. Type Room Instructor Hrs. Units Days Begin-End Footnotes

Sect. Type Room Instructor Hrs. Units Days Begin-End Footnotes

ENGLISH - LEARNING COMMUNITIES



The following groups of courses are learning communities. You must enroll in both complementary courses which have linked curriculum with the following theme: *Speak Up! Speak Out! Voices at Home, in School and in the World.*

ENGL 420 Reading Improvement

4376 L/L CJ500 WARREN K 4.40 3.0 MW 0945A-1110A 1 36
LI120 WARREN K F 0910A-1010A

ENGL 440 Basic Writing

4389 L/L CJ500 WARREN K 4.40 3.0 MW 1120A-1245P 1 36 18
LI120 WARREN K F 1020A-1120A

or

ENGL 420 Reading Improvement

4377 L/L CJ500 WARREN K 4.40 3.0 MW 0945A-1110A 1 36
LI120 WARREN K M 1255P-0155P

ENGL 440 Basic Writing

4390 L/L CJ500 WARREN K 4.40 3.0 MW 1120A-1245P 1 36 18
LI120 WARREN K W 1255P-0155P

or

ENGL 420 Reading Improvement

4379 L/L CJ500 SMITH K 4.40 3.0 MW 1120A-1245P 1 36
LI120 SMITH K Th 1055A-1155A

ENGL 440 Basic Writing

4388 L/L CJ500 SMITH K 4.40 3.0 MW 0945A-1110A 1 18
LI120 SMITH K Th 0945A-1045A

or

ENGL 420 Reading Improvement

4378 L/L CJ500 SMITH K 4.40 3.0 MW 1120A-1245P 1 36
LI120 SMITH K Tu 1055A-1155A

ENGL 440 Basic Writing

4387 L/L CJ500 SMITH K 4.40 3.0 MW 0945A-1110A 1 18
LI120 SMITH K Tu 0945A-1045A

Your educational plan:

You are expected to take the responsibility for scheduling an appointment with a counselor, preferably at least once a semester. The purpose of this appointment is to develop, review and update your educational plan to ensure that you are taking the appropriate courses to meet your educational goal.

ENGL 260 Preparation for College Reading

Prerequisite: Completion of English 420 or ESL 562 with a grade of 'C' or better or Assessment recommendation.
Transferable: No; GAV-GE: A3

This is a course presenting strategies in the technique and practice of college level critical reading and thinking skills.

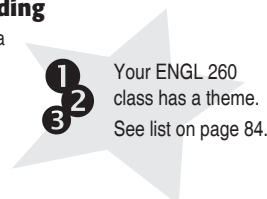

LEARNING COMMUNITY SECTIONS:

4370 LEC HU102 HOOPER J 3.40 3.0 TuTh 0945A-1110A 1 73
Above class requires a co-requisite of First Year Experience English 250 and GUID 1

4371 LEC HU102 HOOPER J 3.40 3.0 TuTh 0945A-1110A 1 73
Above class requires a co-requisite of First Year Experience English 250 and GUID 1

4373 LEC HU103 HOOPER J 3.40 3.0 TuTh 1120A-1245P 1 73
Above class requires a co-requisite of First Year Experience English 250 and GUID 1

4374 LEC HU103 HOOPER J 3.40 3.0 TuTh 1120A-1245P 1 73
Above class requires a co-requisite of First Year Experience English 250 and GUID 1

OTHER SECTIONS:

4368 LEC HU102 TICE R 3.40 3.0 TuTh 0810A-0935A 1

4369 LEC SS203 HOOPER J 3.40 3.0 MW 0945A-1110A 1

4372 LEC SS203 JACKSON J 3.40 3.0 F 1030A-0140P 1

4375 LEC SS203 HOOPER J 3.40 3.0 MW 1255P-0220P 1

6103 LEC SS203 GRAY J 3.40 3.0 M W 0530P-0655P 1 48

ENGL 420 Reading Improvement

Prerequisite: Satisfactory score on the English placement examination.

Transferable: No

This is a practical, "how to" course teaching various methods of learning and reading college material. Using group and individual instruction in vocabulary, comprehension, and study skills, the students will increase their ability to survive academically, to profit, grow and succeed in all college courses, and to enjoy reading and learning. Units earned in this course do not count toward the associate degree and/or certain certificate requirements.

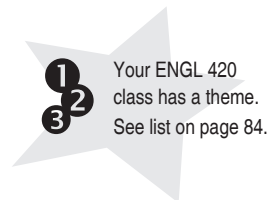

LEARNING COMMUNITY SECTIONS:

12 4376 L/L CJ500 WARREN K 4.40 3.0 MW 0945A-1110A 1 36
LI120 WARREN K F 0910A-1010A

12 4377 L/L CJ500 WARREN K 4.40 3.0 MW 0945A-1110A 1 36
LI120 WARREN K M 1255P-0155P

12 4379 L/L CJ500 SMITH K 4.40 3.0 MW 1120A-1245P 1 36
LI120 SMITH K Th 1055A-1155A

12 4378 L/L CJ500 SMITH K 4.40 3.0 MW 1120A-1245P 1 36
LI120 SMITH K Tu 1055A-1155A

OTHER SECTIONS:

4380 L/L SS111 HIRASUNA S 4.40 3.0 MW 1255P-0220P 1
HIRASUNA S M 0230P-0330P

4381 L/L SS111 HIRASUNA S 4.40 3.0 MW 1255P-0220P 1
HIRASUNA S W 0230P-0330P

4382 L/L SS111 SOLTIS M 4.40 3.0 TuTh 1255P-0220P 1
SOLTIS M Tu 0230P-0330P

4383 L/L SS111 SOLTIS M 4.40 3.0 TuTh 1255P-0220P 1
SOLTIS M Th 0230P-0330P

6104 L/L SS203 GARDNER L 4.40 3.0 TuTh 0530P-0735P 1 48

Sect. Type Room Instructor Hrs. Units Days Begin-End Footnotes

Sect. Type Room Instructor Hrs. Units Days Begin-End Footnotes

ENGL 439 Basic Grammar and Reading

Advisory: Assessment recommendation.
Transferable: No

This is a remediation course introducing basic reading and writing strategies, as well as study skills. Group and individual instruction will be used to build vocabulary, increase reading comprehension, develop study skills, and apply basic grammar to writing. Units earned in this course do not count toward the associate degree and/or certain certificate requirements. This is a credit/no credit course.

4384	L/L	LI120	TICE R	6.80	4.0	MW	0945A-1110A	
		SS111	TICE R			TuTh	0945A-1110A	

ENGL 440 Basic Writing

Prerequisite: Satisfactory score on the English placement examination.
Transferable: No

This is an intensive study and application of basic grammar, sentence, and essay writing skills within the context of composing short essays. Units earned in this course do not count toward the associate degree and/or certain certificate requirements.

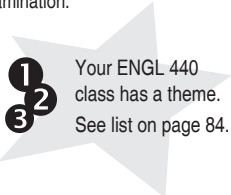

1 Your ENGL 440
2 class has a theme.
3 See list on page 84.

LEARNING COMMUNITY SECTIONS:

4387	L/L	CJ500	SMITH K	4.40	3.0	MW	0945A-1110A	1 18
		LI120	SMITH K			Tu	0945A-1045A	
4388	L/L	CJ500	SMITH K	4.40	3.0	MW	0945A-1110A	1 18
		LI120	SMITH K			Th	0945A-1045A	
4389	L/L	CJ500	WARREN K	4.40	3.0	MW	1120A-1245P	1 36 18
		LI120	WARREN K			F	1020A-1120A	
4390	L/L	CJ500	WARREN K	4.40	3.0	MW	1120A-1245P	1 36 18
		LI120	WARREN K			W	1255P-0155P	

OTHER SECTIONS:

4385	L/L	SS203	GIER J	4.40	3.0	TuTh	0810A-0935A	1 18
		LI171	GIER J			Tu	1010A-1110A	
4386	L/L	SS203	GIER J	4.40	3.0	TuTh	0810A-0935A	1 18
		LI171	GIER J			Th	1010A-1110A	
4391	L/L	HU102	CROOK E	4.40	3.0	MW	1120A-1245P	1 18
		LI171	CROOK E			Tu	1120A-1220P	
4392	L/L	HU102	CROOK E	4.40	3.0	MW	1120A-1245P	1 18
		LI171	CROOK E			Th	1120A-1220P	
4393	L/L	SS203	GIER J	4.40	3.0	TuTh	1120A-1245P	1 18
		LI171	GIER J			Tu	1255P-0155P	
4394	L/L	SS203	GIER J	4.40	3.0	TuTh	1120A-1245P	1 18
		LI171	GIER J			Th	1255P-0155P	
6105	L/L	SS203	GARDNER L	4.40	3.0	TuTh	0740P-0945P	1 18 48

FACULTY Profile

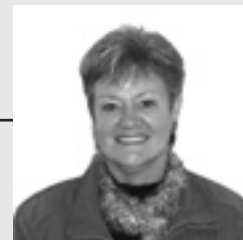

Johanna Stewart:

Johanna Stewart, Counselor/ASB Advisor (jstewart@gavilan.edu)
Ms. Stewart has been a part-time counselor at Gavilan College. In her new role she will continue to counsel students, and will also serve as advisor to the Associated Student Body student governance organization. She holds an MA in Counseling Education from San Jose State University.

Gavilan College

ENGLISH COMPOSITION COURSE SEQUENCE

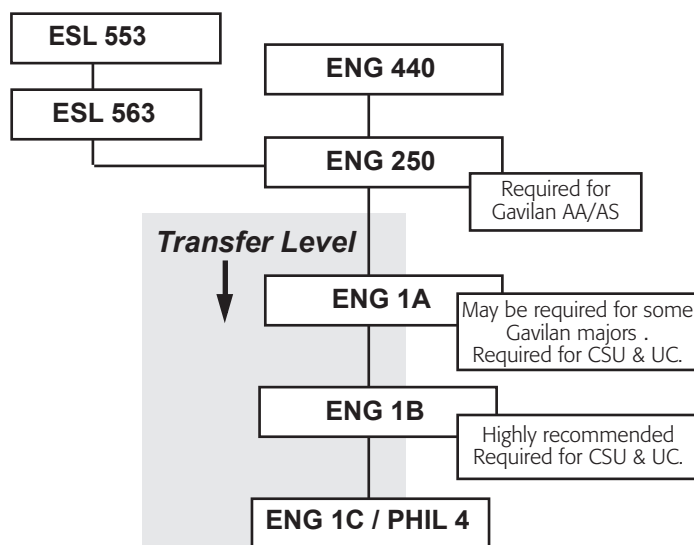

Reading Course Sequence

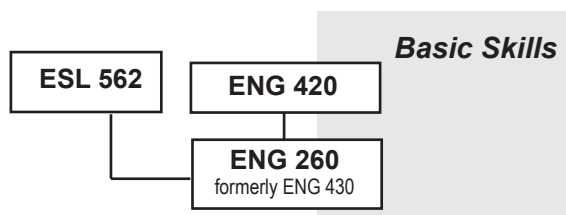

Multiple measures will be considered to determine your final course. Consult with a counselor to select the appropriate course placement.

Footnotes contain valuable information pertaining to your class selection. Footnotes follow class listings.

Sect. Type Room Instructor Hrs. Units Days Begin-End Footnotes

All new ESL students must go through the ESL assessment process. See page 32.

Todos los nuevos estudiantes de ESL deben tomar el examen de nivelación de ESL. Consulte la página 32.

ENGLISH AS A SECOND LANGUAGE

Gavilan College ofrece cursos de Inglés como segundo idioma a todos los niveles, desde principiante hasta avanzado. Antes de inscribirse, los estudiantes deben hacer una cita para el examen de nivelación en la Oficina de Admisiones.

ESL 501A Survival ESL I First Half

Advisory: ESL assessment recommendation

Transferable: No

This is the first half of a course in survival English for students with little or no oral or written English competency. It will give students basic vocabulary and familiarity in life skill areas such as the family, food, health, and occupations. The course integrates listening, speaking, reading, and writing. (ESL 501, 502, and 503 are sequential courses that may be taken in full form or in halves, preferably A before B.) This is a credit/no credit course.

6106	L/L	MHG12	PORCELLA A	5.70	3.0	M WTh	0600P-0735P
Above class meets at Morgan Hill Community site							

6107	L/L	HU101	GUZMAN D	5.70	3.0	TuWTh	0600P-0735P
------	-----	-------	----------	------	-----	-------	-------------

6108	L/L	HOL6	CISNEROS N	5.70	3.0	M WF	0600P-0735P
Above class meets at the Hollister Briggs site							

ESL 501B Survival ESL I Second Half

Advisory: ESL 501A or ESL assessment recommendation

Transferable: No

This is a second half of a course in survival English for students with little or no oral or written English competency. It will give students basic vocabulary and familiarity in life skill areas such as the family, food, health, and occupations. The course integrates listening, speaking, reading, and writing. (ESL 501, 502, and 503 are sequential courses that may be taken in full form or in halves, preferably A before B.) This is a credit/no credit course.

6109	L/L	HU101	GUZMAN D	5.70	3.0	TuWTh	0745P-0920P
------	-----	-------	----------	------	-----	-------	-------------

6110	L/L	HOL6	CISNEROS N	5.70	3.0	M WF	0745P-0920P
Above class meets at the Hollister Briggs site							

ESL 502A Survival ESL II First Half

Advisory: ESL 501 or ESL 501A and 501B or ESL assessment recommendation

Transferable: No

This is the first half of a second course in survival English for students with little oral or written English competency. It will give students expanded basic vocabulary and familiarity in life skill areas such as the weather, transportation, employment, and American holidays and customs. The course integrates listening, speaking, reading, and writing. (ESL 501, 502, and 503 are sequential courses that may be taken in full form or in halves, preferably A before B.) This is a credit/no credit course.

6111	L/L	HU104	LEE P	5.70	3.0	TuWTh	0600P-0735P
------	-----	-------	-------	------	-----	-------	-------------

ESL 502B Survival ESL II Second Half

Advisory: ESL 501 or ESL 501A and 501B or ESL assessment recommendation

Transferable: No

This is the second half of the second course in survival English for students with little oral or written English competency. It will give students expanded basic vocabulary and familiarity in life skill areas such as weather, transportation, employment, and American holidays and customs. The course integrates listening, speaking, reading, writing. (ESL 501, 502, and 503 are sequential courses that may be taken in full form or in halves, preferably A before B.) This is a credit/no credit course.

6112	L/L	HOL4	DIEHL K	5.70	3.0	M WF	0600P-0735P
Above class meets at the Hollister Briggs site							

Sect. Type Room Instructor Hrs. Units Days Begin-End Footnotes

ESL 503A Survival ESL III First Half

Advisory: ESL 502 or ESL 502A and 502B or ESL assessment recommendation

Transferable: No

This is the first half of a third course in survival English for students with beginning oral or written English competency. It will reinforce basic skills learned and continue to develop vocabulary and ease of communication in life skill areas such as the family, the larger community, health, employment, and leisure activities. The course integrates listening, speaking, reading, and writing. (ESL 501, 502, and 503 are sequential courses that may be taken in full form or in halves, preferably A before B.) This is a credit/no credit course.

6113	L/L	HU104	LEE P	5.70	3.0	TuWTh	0745P-0920P
------	-----	-------	-------	------	-----	-------	-------------

6114	L/L	HOL4	DIEHL K	5.70	3.0	M WF	0745P-0920P
Above class meets at the Hollister Briggs site							

ESL 510A Basic ESL I

Advisory: Assessment Recommendation.

Transferable: No

This is an intensive, integrated-skill course for students with little English. Through listening, speaking, reading and writing activities, students learn to use the structures of English with increasing accuracy, while gaining basic life skills. This is a credit/no credit course.

4395	L/L	OE001	MORA J	12.90	8.0	F&2.3	0810A-1000A
			MORA J			MTuWTh&2	0810A-1015A

4396	L/L	OE001	POLIZZOTTO J	12.90	8.0	F&2.3	1025A-1215P
			POLIZZOTTO J			MTuWTh&2	1025A-1230P

ESL 510B Basic ESL II

Advisory: ESL 510A or ESL assessment recommendation.

Transferable: No

This course is a continuation of ESL 510A. This is an intensive, integrated-skill program for students who function in a limited way in English. Through listening, speaking, reading and writing activities, students continue learning to use the structures of English with increasing accuracy, while gaining further basic life skills. This is a credit/no credit course.

4397	L/L	CH102	BAAMEUR K	12.90	8.0	F&2.3	0810A-1000A
			BAAMEUR K			MTuWTh&2	0810A-1015A

4398	L/L	OE002	WEXLER L	13.60	8.0	F&2.3	0925A-1115A
			WEXLER L			MTuWTh&2	0925A-1130A

ESL 521 Beginning ESL Listening/Speaking

Advisory: ESL 510B or ESL Assessment Test Recommendation. Recommended concurrent enrollment in ESL 522 and 523.

Transferable: No

This course develops basic listening and speaking skills, moving from a functional survival context to academic readiness. Activities are directed at providing practice through listening exercises, role-play, pair work, small and large group discussion, interviews, and oral presentations.

4399	L/L	HU101	SANIDAD M	6.80	4.0	MW	0925A-1030A
			SANIDAD M			TuTh	0925A-1015A

ESL 522 Beginning ESL Reading/Vocabulary

Advisory: ESL 510B or 510C or Assessment recommendation. Recommended concurrent enrollment in ESL 521 and 523.

Transferable: No

This course begins the development of reading skills and vocabulary through the application of different reading strategies to a variety of selections on topics of interest to academically-bound students.

4400	L/L	HU101	CARRILLO L	5.70	3.0	MW	1155A-1245P
			CARRILLO L			F	1155A-0100P

6115	L/L	LI100	SHELLEY A	5.70	3.0	TuWTh	0600P-0655P
			LI200				0705P-0740P

Sect. Type Room Instructor Hrs. Units Days Begin-End Footnotes

ESL 523 Beginning ESL Grammar/Writing

Advisory: ESL 510B or ESL Assessment Test recommendation. Recommended concurrent enrollment in ESL 521 and ESL 522.

Transferable: No

This is a beginning grammar/writing course for students with very basic grammar. The focus is on basic grammatical structures, punctuation and sentence skills.

4401 L/L HU104 CAMPBELL K 6.60 5.0 MWF 1040A-1130A
CAMPBELL K TuTh 1040A-1145A

ESL 531 Intermediate ESL Listening/Speaking I

Advisory: ESL 521 or ESL Assessment Test Recommendation. Recommended concurrent enrollment in ESL 532 and 533.

Transferable: No

In this course, listening and speaking skills are developed through extended listening exercises, open-ended dialogues, pair and group discussions, oral interviews, and oral reports. Units earned in this course do not count toward the associate degree and/or certain certificate requirements.

4402 L/L HU101 WEXLER L 6.80 4.0 MW 0810A-0915A
WEXLER L ThF 0810A-0900A

ESL 532 Intermediate ESL Reading/Vocabulary I

Advisory: ESL 522 or ESL Assessment Recommendation. Recommended concurrent enrollment in ESL 531 and 533.

Transferable: No

This course continues the development of reading skills and vocabulary through the application of different reading strategies to a variety of selections on topics of interest to academically-bound students.

4403 L/L OE002 CARRILLO L 5.70 3.0 TuTh 1155A-0120P

ESL 533 Intermediate ESL Grammar/Writing I

Prerequisite: ESL 523 with a grade of C or better or ESL Assessment Test recommendation.

Corequisite: Recommended concurrent enrollment in ESL 531 and ESL 532.

Transferable: No

This course involves the practice and refinement of sentence and paragraph skills, structure and punctuation. Students will learn basic use of the computer as a writing tool. Units earned in this course do not count toward the associate degree and/or certain certificate requirements.

4404 L/L LI100 LAWN B 6.60 5.0 MWF 1040A-1130A
LAWN B TuTh 1040A-1145A

ESL 541 Intermediate ESL Listening/Speaking II

Advisory: ESL 531 or ESL Assessment Recommendation. Recommended concurrent enrollment in ESL 542 and 543.

Transferable: No

This course expands listening and speaking skills through extended listening exercises, open-ended dialogues, pair and group discussions, oral interviews, and oral reports. Students broaden vocabulary while listening to and speaking in both formal and informal, conversational and academic situations.

4405 L/L OE002 MAXWELL K 6.80 4.0 MW 0810A-0915A
TuTh 0810A-0900A

ESL 542 Intermediate ESL Reading/Vocabulary II

Advisory: ESL 532 or ESL Assessment Recommendation. Recommended concurrent enrollment in ESL 541 and 543.

Transferable: No

This course begins the expansion of reading skills and vocabulary development through the application of different reading strategies to a variety of selections on topics of interest to academically-bound students including selections from literature.

4406 L/L OE002 WEXLER L 5.70 3.0 MW 1155A-1245P
WEXLER L F 1155A-0100P

OVERVIEW OF ESL COURSES

L/S = Listening/Speaking
R = Reading
GW = Grammar/Writing

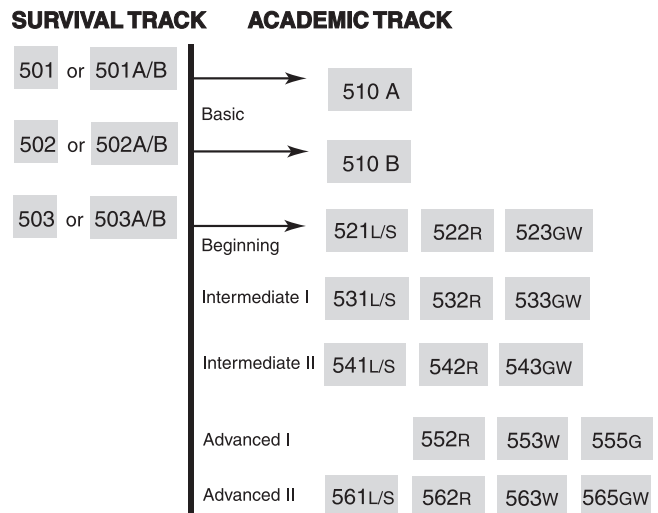

SUPPLEMENTARY ESL COURSES:

- ESL 546 Introduction to Computers/ESL
- ESL 556 Information Competency for ESL
- ESL 581 Pronunciation I
- ESL 582 Pronunciation II
- ESL 584 Culture through Film

ENGL 260 ENGL 250



ESL 565 - EDITING FOR ESL WRITERS

Do you want to write more clearly and avoid common ESL writing errors? Then check out our new Editing for ESL Writers class!



Watch for NEW SUMMER ESL classes:

**ESL 581 ESL PRONUNCIATION I and
ESL 582 ESL PRONUNCIATION II**

Learn to speak more clearly and be better understood in two new ESL Pronunciation courses being offered this summer!

ESL 584 CULTURE THROUGH FILM

Learn more about American culture and improve your listening/speaking skills while watching movies in this new intermediate/advanced ESL class being offered this summer!

Sect. Type Room Instructor Hrs. Units Days Begin-End Footnotes

ESL 543 Intermediate ESL Grammar/Writing II

Prerequisite: ESL 533 with a grade of C or better or ESL assessment recommendation.
Corequisite: Recommended concurrent enrollment in ESL 541 and ESL 542.
Transferable: No
 This course is a continuation of ESL 533. Units earned in this course do not count toward the associate degree and/or certain certificate requirements.

4407	L/L	LI100	LAWN B LAWN B	6.60 5.0	MWF TuTh	0925A-1015A 0925A-1030A
------	-----	-------	------------------	----------	-------------	----------------------------

ESL 552 Advanced ESL Reading/Vocabulary I

Advisory: ESL 542 or ESL Assessment Recommendation. Recommended concurrent enrollment in ESL 553 and/or ESL 555.
Transferable: No
 This course focuses on academic and critical thinking skills needed to increase reading comprehension and efficiency. Emphasis is on analyzing, making inferences, taking notes, supporting opinions, summarizing and expanding vocabulary. Readings are from academic texts and literature.

4408	LEC	LI100	LAWN B LAWN B	4.50 4.0	MTu ThF	1155A-1245P 1155A-0100P
------	-----	-------	------------------	----------	------------	----------------------------

ESL 553 Advanced ESL Composition I

Prerequisite: ESL 543 with a grade of C or better or ESL Assessment Test recommendation.
Corequisite: Recommended concurrent enrollment in ESL 552 and ESL 555.
Transferable: No
 This course is a composition course for ESL students that develops college composition skills through a review of the parts and elements of the English paragraph and an introduction to the essay form. The course focuses on the development of a paragraph and expands to the writing of multiple paragraphs in an essay. Basic rhetorical patterns and methods of organization are covered using the multiple-draft approach to writing.

4409	L/L	LI100	SANIDAD M SANIDAD M	6.60 5.0	MWF TuTh	0810A-0900A 0810A-0915A
------	-----	-------	------------------------	----------	-------------	----------------------------

ESL 555 Advanced ESL Grammar

Prerequisite: ESL 543 with a grade of C or better or ESL Assessment Test Recommendation.
Advisory: Recommended concurrent enrollment in ESL 553 and ESL 552.
Transferable: No
 This course is designed to help students improve their grammar usage so that they will be able to succeed in English composition courses. Students will enhance their writing skills by practicing with previously encountered basic structures as well as newly acquired more sophisticated ones.

4410	L/L	HU104	CAMPBELL K CAMPBELL K	6.60 5.0	MWF TuTh	0925A-1015A 0925A-1030A
------	-----	-------	--------------------------	----------	-------------	----------------------------

ESL 562 Advanced ESL Reading/Vocabulary II

Advisory: ESL 552 or ESL Assessment recommendation. Recommended concurrent enrollment in ESL 563.
Transferable: No
 This course prepares ESL students for mainstream college classes by reviewing a variety of reading skills, strategies, and topics from different academic disciplines. Students expand their academic vocabulary and read short stories or a novel for literary appreciation.

4411	LEC	HU104	CAMPBELL K CAMPBELL K	4.50 4.0	MTu ThF	0810A-0900A 0810A-0915A
------	-----	-------	--------------------------	----------	------------	----------------------------

ESL 563 Advanced ESL Composition II

Prerequisite: ESL 553 with a grade of "C" or better or ESL Assessment Test recommendation.
Advisory: Recommended concurrent enrollment in ESL 561.
Transferable: No
 This course which is designed for ESL students, refines and further expands college composition skills through the writing of essays using the multiple-draft approach to writing. The course focuses on the structuring and development of an essay with the use of personal examples and/or outside sources. Students write in response to a variety of prompts and viewpoints on issues using different rhetorical patterns, and they are introduced to writing tasks used in academic disciplines other than English.

4412	L/L	HU104	TRACEY I TRACEY I	6.60 5.0	MWF TuTh	1155A-1245P 1155A-0100P
------	-----	-------	----------------------	----------	-------------	----------------------------

Sect. Type Room Instructor Hrs. Units Days Begin-End Footnotes



ESL 565 Editing for ESL Writers

Assessment recommendation.
Transferable: No
 This course is designed to help second language writers develop self-editing techniques to improve their writing. Students learn to identify and correct grammatical and usage errors in their writing as they become aware of general linguistic rules of English. Students learn to fix, and ultimately avoid, many of the errors commonly made by second language writers.

4413	L/L	HU101	MAXWELL K MAXWELL K	4.40 3.0	MW F	1040A-1130A 1040A-1145A
------	-----	-------	------------------------	----------	---------	----------------------------

FRENCH

FRNH 1A Elementary French

Transferable: CSU; UC; CSU-GE: C2; GAV-GE: C2
 French 1A is a multi-skilled beginning level class with emphasis on understanding and speaking French. Students are introduced to the cultures and customs of various French-speaking countries.

4414	L/L	HU101	SANIDAD M	5.60 5.0	MTuWTh&2.8	1255P-0205P
------	-----	-------	-----------	----------	------------	-------------

GEOGRAPHY

see also CSIS 61 (Geographic Info. Systems)

GEOG 1 Physical Geography

Advisory: Eligible for English 250 and English 260.
Transferable: CSU; UC; CSU-GE: B1, B3; IGETC: 5A; GAV-GE: B1, B3; CAN: GEOG 2
 An introductory study of the basic physical elements of geography including climate, land forms, soils, water, and natural vegetation. The laboratory will include the tools and methods of geographers.

4905	L/L	HOL5	WILLAHAN D	5.60 3.0	MW	0945A-1215P
------	-----	------	------------	----------	----	-------------

Above class meets at Hollister Briggs site.

GEOLOGY

GEO 1 Introduction to Geology

Advisory: Eligible for English 250 and English 260.
Transferable: CSU; UC; CSU-GE: B1, B3; IGETC: 5A; GAV-GE: B1, B3; CAN: GEOL 2
 A study of the earth and the physical properties which modify the earth; minerals, rocks, geologic structures and processes.

4418	L/L	CH102	WILLAHAN D	6.80 4.0	MW	1255P-0405P 1
------	-----	-------	------------	----------	----	---------------

GUIDANCE - PUENTE

The Puente Project is a two-semester program that combines three components: writing, counseling and mentoring to support students to transfer to four-year universities and colleges. The Guidance 1 course focuses on self-assessment and career development. The English 1A course focuses on Mexican American/Latino literature. The program is open to all eligible students. For more information, call Celia Marquez, Puente Co-Coordinator at 408-848-4807.

ENGL 1A Composition

4305	LEC	HU103	CANDELARIA X	3.40 3.0	TuTh	0945A-1110A 1827
------	-----	-------	--------------	----------	------	------------------

GUID 1 Self Assessment and Career Development

4419	LEC	CH102	MARQUEZ C MARQUEZ C	2.30 2.0	M W	1120A-1220P 50 82 89 1120A-1225P
------	-----	-------	------------------------	----------	--------	-------------------------------------