



# Gavilan College

## Spring 2007 Semester

# CALENDAR

### ALTERNATE FORMATS:

The Gavilan College Schedule of Classes is available in alternate media formats. Contact the Disability Resource Center (408-848-4865) or the Office of the Vice President of Student Services (408-848-4738).

### FORMAS ALTERNATIVAS:

El Horario de Clases del Colegio Gavilán está disponible en formato de medios alternos.

Por favor de contactar El Centro de Recursos Para Estudiantes con Incapacidades (DRC) (408-848-4865) o la Oficina del Vicepresidente de Servicios de Estudiante (408-848-4738).

<b>WINTER INTERSESSION</b>	<b>Wed, Jan 3 - Fri, Jan 26</b>
See calendar and course listings beginning on page 54.	
<b>SPRING SEMESTER BEGINS</b>	<b>Wed, Jan 31</b>
<b>LAST DAY TO OBTAIN &amp; USE ADD CODES</b>	<b>Tues, Feb 6</b>
for closed classes (unless class is open entry or late-start.) See class list on page 49.	
<b>ADD CODES ACCEPTED UNTIL</b>	<b>Tues, Feb 6</b>
Students must use add code to register by phone or in person no later than this date.	
<b>LAST DAY TO DROP WITH A REFUND</b>	<b>Fri, Feb 14</b>
See page 6.	
<b>PRESIDENT'S DAY HOLIDAYS</b>	<b>Fri, Feb 16 - Mon, Feb 19</b>
No day, evening or weekend classes.	
<b>"NRS" DEADLINE</b>	<b>Fri, Mar 2</b>
"No Record Shown". Semester-long courses dropped by this date do not appear on the student's permanent record. The "NRS" deadline for a short-term course is 30% of the class meetings.	
<b>DEADLINE FOR GRADING OPTION</b>	<b>Fri, Mar 2</b>
Last day to select the Cr/NC/Letter Grade option for designated, semester-long courses.	
<b>SPRING GRADUATION PETITIONS DUE</b>	<b>Mon, April 2</b>
See a counselor to complete a petition to graduate at the end of the spring semester.	
<b>SPRING BREAK</b>	<b>Mon, April 9 - Fri, April 13</b>
No day or evening classes. Weekend classes resume on Saturday, April 14.	
<b>FRIDAY BEFORE EASTER</b>	<b>Fri, April 13</b>
No day or evening classes.	
<b>"W" DEADLINE</b>	<b>Fri, April 27</b>
Semester-long courses dropped by this date appear on the student's permanent record with a notation of "W" for withdrawn. The "W" deadline for a short-term course is 75% of the course meetings.	
<b>TRANSFERRING STUDENTS</b>	<b>Mon, April 30</b>
Students transferring to a CSU or UC campus in the fall should request a GE or IGETC certification from the Admissions and Records Office by this date.	
<b>FINAL EXAMS</b>	<b>Sat, May 19 - Fri, May 25</b>
<b>LAST DAY OF SEMESTER</b>	<b>Fri, May 25</b>
<b>GRADUATION</b>	<b>Fri, May 25 at 6:30 pm</b>
<b>FINAL GRADES AVAILABLE</b>	<b>Mon, June 18, 2007</b>
Grades available on GavNOW (408-846-3729) and OLGA (www.gavilan.edu)	

<b>Spring Registration</b> . . . . .	page 5
<b>Winter Intersession</b> . . . . .	page 54

<b>SUMMER Preview</b> . . . . .	pages 122-125
---------------------------------	---------------

Información  
en Español  
... página 32-35



# Table of Contents

Welcome to Gavilan College	2
Administrators	2
Board of Trustees	2
Telephone Numbers	3
Getting Started	4
Register for Spring Classes	5
Fees	6-7
Financial Aid	7-10
Matriculation	11-12
Assessment	11
Orientation	11
Counseling Services	12
High School Students	12-15
Transfer	16-22
Student Life	23
General Information	24
Policies and Procedures	25-26
Student Services	27-28
Instructional Support and Labs	29
How to Use the Schedule	31
English as a Second Language (ESL)	32
Información en Español	32-35
Spring Classes at a Glance:	
Block Schedule	36-39
Noncredit Program	40-43
ROP Courses	44-45
Online Classes (Spring)	46
Telecourses (Gavilan College & SJSU)	47
Weekend Courses	48
Late Afternoon and Evening Courses	48
Late Start, Short Term Courses	49
Morgan Hill Classes	50-51
Hollister Classes	52-53
Winter Intersession	54-57
Calendar / Registration	54
Classes	55
Spring Semester Class Listings	58
New Spring Classes	58
First Year Experience	87
Final Exam Schedule	121
Summer Preview	122-125
Maps	inside back cover

## Welcome to Gavilan College!



We're rebuilding, from the ground up. When you visit the Gavilan College campus in Gilroy now, you'll notice all of the construction activity underway. A new boiler system has just gone in, and new infrastructure for electricity, gas, water, and communications will make the Gavilan college campus functional, comfortable, and

"wired". Once the infrastructure is complete, work will begin to renovate each building with Smart classrooms, better internal arrangements, air conditioning, and exterior lighting. After Measure E funds are spent, the campus will look much the same as it does now -- from the outside. The buildings will retain their low-key, natural material exteriors and will remain the same size and shape. The insides, however, will have greater flexibility, functionality, and technology. It's not a bad metaphor for education itself -- while it won't change you on the outside, it can give you the skills, knowledge and technological capability to compete in the global marketplace and to be more effective at whatever you do. Build with us!

Sincerely,

*Steven M. Kinsella*

Steven M. Kinsella, D.B.A., C.P.A.  
Superintendent/President

### Schedule Development Team

Rosie Armstrong, Mimi Arvizu, Sherrean Carr, Jan Bernstein Chargin, Michele Cortes, Katie Day, Bonnie Donovan, Natalie Juarez, Fran Lopez, Michelle Lopez, Fran Lozano, Oralis Magaña, Terri Newman, Jesus Olivas, Joy Parker, Rachel Perez, Dave Phillips, John Pruitt, Cindy Starr, Dennie VanTassel

Cover by: Jan Bernstein Chargin

Photos by: Jan Bernstein Chargin, Cindy Starr

Printed by: Casey Printing

# Degrees Currently Offered

by Gavilan College

## **Associate of Arts**

Administration of Justice  
Art  
Business  
Child Development  
Fine Arts  
Interpersonal Communications  
Language Arts  
Liberal Arts  
Media Arts  
Music  
Physical Education  
Social Science  
Spanish  
Theatre Arts

## **Associate of Science**

Aviation Maintenance  
Technology  
Biological Science  
Business:  
Economics Option  
Computer Graphics & Design  
Computer Science and  
Information Systems  
Cosmetology  
Digital Media  
Engineering & Physical Science  
Health Science  
Mathematics  
Nursing (LVN/RN)

ACCURACY STATEMENT: The Gavilan Joint Community College District and Gavilan College have made every reasonable effort to ensure that the 2007 Spring/Summer Class Schedule is accurate. Courses and programs that are offered, along with other information in the schedule, are subject to change without notice by the Gavilan College administration for reasons related to student enrollment, level of financial support, or for any other reason, at the discretion of the district and the college. The district and college further reserve the right to add to, amend, or repeal any of its rules, regulations, policies, and procedures, consistent with applicable laws.

## **Administrators**

Steven M. Kinsella, D.B.A., C.P.A., *Superintendent/President*  
Adrienne Akinsete, *Vice President of Instruction*  
Joseph Keeler, C.P.A., *Vice President of Administrative Services*  
John Pruitt, *Vice President of Student Services (Interim)*  
Fran Lozano, *Dean of Liberal Arts and Sciences*  
Sherrean Carr, *Dean of Technical and Public Services*  
Ron Hannon, *Director of Physical Education and Athletics*  
Fran Lopez, *Associate Dean of the Disability Resource Center*  
Rachel Perez, *Associate Dean of Community Development/Grants Management*  
Anne Ratto, *Associate Dean of EOPS/CalWORKs and CARE*

Gavilan Joint Community College District

## **Board of Trustees**

Tom Breen, *San Benito County*  
B.S., J.D., Santa Clara University  
Kent Child, *San Benito County*  
A.A., College of San Mateo; B.A., M.A., San Jose State University  
Mark Dover, *Gilroy*  
B.S., M.A., San Jose State University  
Laura Perry, Esq., *Morgan Hill*  
A.A., Gavilan College, B.S., San Jose State University; J.D., Santa Clara University  
Elvira Robinson, Esq., *San Benito County*  
B.A., J.D., Santa Clara University  
Deb Smith, *Gilroy*  
B.S., University of Phoenix  
Leonard Washington, *Morgan Hill*  
B.A., Texas Southern University, M.A., Santa Clara University  
Jesse Sandow, *Student Trustee*

**GAVILAN COLLEGE SATELLITE LOCATIONS:**

**Morgan Hill Community and Cultural Center**

17060 Monterey Road  
Morgan Hill, CA 95037  
408-782-2873

**Hollister, Briggs Bldg.**

365 Fourth St.  
Hollister, CA 95023  
831-636-3783

**Hollister Airport**

490 Skylane Drive  
Hollister, CA 95023  
831-637-1151

**Telephone Numbers**

Main Campus . . . . .	408-848-4800	Foundation/Fundraising . . . . .	408-846-4936
from Hollister, call toll free . . . . .	.637-1158	GavTV, Channel 18 . . . . .	408-848-4764
Morgan Hill Site . . . . .	408-782-2873	The Gavilan Press . . . . .	408-848-4837
Hollister Site, Briggs Building . . . . .	831-636-3783	to fax news events . . . . .	408-848-4827
Campus Security (non-emergency) . . . . .	408-848-4703	Health Services . . . . .	408-848-4791
Emergency: <u>First</u> : Dial '911' (On campus, dial '8' first.)		Human Resources . . . . .	408 848 4755
<u>Second</u> : Dial '10' for campus emergency support.		Instructional Services, Vice President's Office . . . . .	408-848-4761
From campus pay phone: Dial 408-710-7490		International Students . . . . .	408-848-4754
Cell phone: 408-710-7490		Liberal Arts & Sciences . . . . .	408-848-4701
<hr/>		Library . . . . .	408-848-4810 or 408-848-4806
Admissions & Records . . . . .	408-848-4735 or 846-4954	Math Lab . . . . .	408-846-4959
ASB Advisor . . . . .	408-846-4972	MESA - Math, Engineering, Science Achievement . . . . .	408-848-4887
ASB Office . . . . .	408-848-4777	Noncredit Program (Community Development) . . . . .	408-848-4859
Assessment Office . . . . .	408-846-4992	Placement/Assessment Testing . . . . .	408-846-4992
Athletics/Physical Education . . . . .	408-848-4876	Sign up . . . . .	408-846-4954
Aviation . . . . .	831-637-1151	Online/Telecourses . . . . .	408 848-4885
Bookstore . . . . .	408-848-4742	Outreach & Recruitment/Tours . . . . .	408-846-4993
CalWORKs . . . . .	408-848-4813	President's Office . . . . .	408-848-4711
CARE - Cooperative Agencies Resources for Education . . . . .	408-848-4790	Public Information Office . . . . .	408-848-4724
Career/Transfer Resource Center . . . . .	408-848-4818	Puente Program . . . . .	408-848-4807
Cashier . . . . .	408-848-4714	Reading Lab . . . . .	408-846-4980
Child Development Center . . . . .	408-848-4815	R.O.P. - Regional Occupational Programs . . . . .	408-848-4816
CMAP - Community Media Access Partnership . . . . .	408-846-4983	Student Services, Vice President's Office . . . . .	408-848-4738
Community/Contract Education . . . . .	408-847-2514	Teach for Tomorrow . . . . .	408-848-4805
Computer Place . . . . .	408-848-4729	Technical and Public Services . . . . .	408-848-4719
Cooperative Work Experience . . . . .	408-846-4993	Telephone Registration (GavNOW) . . . . .	408-846-3729
Cosmetology Appointment line . . . . .	408-842-5055	Theatre Arts Box Office . . . . .	408-846-4973
Counseling Office . . . . .	408-848-4723	Transfer (Career/Transfer Resource Center) . . . . .	408-848-4818
DRC - Disability Resource Center . . . . .	408-848-4767	TRIO Student Support Services . . . . .	408-846-4981
Discrimination-Harassment Complaints . . . . .	408-848-4715	TTY (for Deaf or Hard of Hearing) . . . . .	408-846-4924
Distance Education Coordinator . . . . .	408 848-4885	Tutoring Center . . . . .	408-848-4838
EOPS - Extended Opportunity Programs & Services . . . . .	408-848-4740	Veterans' Counselor . . . . .	408-848-4723
ESL Computer Lab . . . . .	408-848-4856	Veterans' Services . . . . .	408-848-4734
Evening Office . . . . .	408-848-4276	Work Experience . . . . .	408-846-4993
Financial Aid . . . . .	408-848-4727	Writing Center . . . . .	408-848-4811
First Year Experience . . . . .	408-848-4723		

**save gas!  
save time!  
save energy!**

For a list of courses offered, see pages 50 and 52.

Take 12 units of transferable general education classes at the Morgan Hill and Hollister sites in the Spring.

**El Proceso de Registración para el Programa de ESL**  
Consulte la página 36.

**Check out Online Registration**  
go to [www.gavilan.edu](http://www.gavilan.edu) and click on OPGA

# Getting Started

## You are eligible to ATTEND GAVILAN COLLEGE if:

- ◆ You are a high school graduate or
- ◆ You have passed the GED or
- ◆ You are 18 years of age or older or
- ◆ You have passed the California High School Proficiency exam or
- ◆ You are currently enrolled in high school. High School students may co-enroll using a Special Student Status Contract form.

**PLACEMENT/ASSESSMENT** testing will help ensure that students are enrolled in courses that match their abilities in language and computational skills. Students must have completed the eighth grade to be eligible for assessment services. Placement scores, together with other indicators of a student's abilities, are used by counselors to recommend appropriate course placements.

If you have attended another college and completed math and English courses within the past two years, you do not need Gavilan's placement assessment unless you wish to take it or it is required by your major.

### See a COUNSELOR if:

- ◆ you are a first time student planning to transfer
- ◆ you are a first time student planning to obtain an AA/AS degree
- ◆ you are undecided
- ◆ you are a high school contract student
- ◆ you are an academic probation student or in a "disqualified" status
- ◆ you are an international student
- ◆ you are taking over 17.99 units (spring/fall) or over 5.99 units (summer)
- ◆ you have completed prerequisite courses at another college
- ◆ your class has a prerequisite that was not successfully completed at Gavilan

## New Students Registration Checklist

- 1) APPLICATION** File at least 48 hours before registering.
- 2) PLACEMENT/ASSESSMENT TEST** Sign up in person or by calling (408) 846-4992 or (408) 846-4954.
  - a. If you have attended another college you may submit placement test scores from that college to a counselor for evaluation.
  - b. Results are posted approximately 24 hours after test completion.
  - c. If you do not dispute the results of your placement exams, you may register for classes without seeing a counselor.
- 3) ORIENTATION** online or in person
- 4) REQUEST A TRANSCRIPT** from your high school if you graduated within the past five years and have not yet attended college. Request a transcript form any colleges you have attended.
- 5) SEE A COUNSELOR**
- 6) REGISTER FOR CLASSES** Online, by phone or in person
- 7) PAY FEES**

### ADDING AND DROPPING COURSES

Students may add and/or drop courses

- by phone (Call GavNOW at 408-846- 3729),
- online (Click on the OLGA icon at [www.gavilan.edu](http://www.gavilan.edu))
- in person on the main campus or at the Morgan Hill or Hollister sites.

A student who stops attending a course and does not officially drop is not automatically dropped by the instructor and may receive a final grade of "F".

### ADD CODES

are obtained from an instructor during late registration for closed (full) classes.

They must be used by Tuesday, February 6...

...until 7 pm for in person registration or

...until 10 pm for online (OLGA) and phone registration (GavNOW).

### WAITING LISTS

Gavilan College currently does not have waiting lists for classes.

# SPRING 2007 REGISTRATION

## WHEN?

### PRIORITY REGISTRATION FOR CONTINUING STUDENTS

December 4-8, 2006

### TRANSFER INSTITUTE STUDENTS

December 7 - 8

### NEW, RETURNING\* & HIGH SCHOOL CONTRACT STUDENTS

December 11 - 22, 2006

January 3 - 29, 2007

High School students: Refer to the registration checklist on page 13.

### LATE REGISTRATION (New, Continuing, Returning or High School Students)

January 31 - February 6

### OPEN ENTRY & LATE-START CLASSES

Consult the "Short-term Courses & Late Start Course List" on page 49. Students must be registered before the first day of a late-start course.

\* A "returning" student is a student who has been absent from Gavilan College for a semester or more.

## REGISTER IN PERSON

### MAIN CAMPUS

Dec 4 - 15	Mon - Thurs, 8 am - 4:30 pm, Fri, 9 am - 4:30 pm
Dec 18 - 22	Mon - Thurs, 8 am - 6 pm, Fri, 9 - 4:30 pm
Dec 23 - Jan 2	Closed for Christmas Holiday
Jan 3 - 19	Wed - Thurs, 8 am - 4:30 pm, Fri, 9 - 4:30 pm
Jan 15	Closed for Martin Luther King Day
Jan 22 - 26	Tues - Thurs, 8 am - 6 pm, Fri, 9 am - 4:30 pm
Jan 29	Mon, 8 am - 7 pm
Jan 30	Closed for Staff Development Day
Jan 31 - Feb 8	Mon - Thurs, 8 am - 7 pm, Fri, 8 am - 4:30 pm

### MORGAN HILL AND HOLLISTER SITES

Dec 4 - 22	Mon - Thurs, 8 am - 2 pm, 6 - 8 pm, Fri, 8 am - 12 pm, 1 - 5 pm
Dec 23 - Jan 5	Closed for Christmas Holiday
Jan 8 - 29	Mon - Fri, 8 am - 12 pm, 1 - 5 pm
Jan 15	Closed for Martin Luther King Day
Jan 30	Closed for Staff Development Day
Jan 31 - Feb 6	Mon - Thurs, 8 am - 2:30 pm, 5:30 - 8 pm, Fri, 8 am - 12 pm

NEW

## REGISTER ONLINE!

with

# OLGA

On Line Gavilan Access



Go to [www.gavilan.edu](http://www.gavilan.edu)

and click on the **OLGA** icon

Register on the web  
Monday - Friday  
8 am - 10 pm

### Use GavNOW or OLGA if:

1. You are a continuing student or have submitted an application to the Admissions & Records Office or at the sites at least 48 hours prior to registering on the phone or web.
2. You have no "holds".
3. You are signing up for courses with prerequisites that you have successfully completed at Gavilan or have been verified by placement assessment or evaluation of official transcripts from another college.
4. You are not in "dismissed" status.

- ✓ Register/Add/Drop
- ✓ Check Class Schedule/Fees
- ✓ CR/NC Option
- ✓ Check Semester Grades
- ✓ Open Class Finder
- ✓ Purchase Parking Permits or Student ID Cards
- ✓ Check Prerequisites
- ✓ Obtain an Unofficial Transcript

Pay with MasterCard or Visa

### OLGA Helpline:

8 am - 5 pm (Mon-Fri), call (408) 848-4733



## REGISTER BY PHONE call GavNOW

at 408-846-3729

Mon-Fri, 9 am - 10 pm

CHECKS and CREDIT CARDS  
accepted for telephone registration!

You will need.....

- \* Your Social Security number or student ID number
- \* Section numbers for your classes.

If paying by check do NOT bring your payment to the Admissions and Records Office. You will not be billed. Mail your payment within 5 days to:

Cashier, Business Office  
Gavilan College  
5055 Santa Teresa Blvd  
Gilroy, CA 95020

### GavNOW Helpline:

8 am - 5 pm (Mon-Fri), call (408) 848-4733

# Fees

## Basic Fees

Per unit fee (California resident).....	\$20
Per unit fee (non-resident).....	\$194
Health Fee: fall/spring .....	\$14
summer.....	\$5
Campus Center Use Fee (fall & spring only): ..... \$1 per unit to a maximum of \$5	
This fee is not required of students whose entire course load is held off campus.	
Student Representation Fee .....	\$1
Student Identification Card Fee (per semester).....	\$6

## Parking Permits

Required only on the Gilroy campus Monday-Friday

Day Permit (7 a.m. - 10 p.m.).....	\$40
Day Permit with TANF/AFDC/SSI or Financial Aid.....	\$20
Evening Permit (3 p.m. - 10 p.m.) .....	\$20
Summer .....	\$20

One-day permits may be purchased from the coin-operated machines located in parking lots A, E and at the south entrance to campus for 75 cents. Exact change is required.

## Refunds

Students must drop no later than 5 p.m. on Wednesday, February 14 and file a Request for Refund form no later than Wednesday, February 28, 2007. Short-term courses must be dropped before 10% of the course meetings have passed. For one- or two-day courses, this date will occur before the start of the course.

Fees, minus a \$10 processing fee, will be refunded when semester-long courses are officially dropped by the refund date. Refunds are not automatic, even when a class is cancelled.

## Student Health Fees

Gavilan College is required to maintain health services and accident insurance for all students enrolled in credit classes. The \$14 health fee covers students for injuries or accidents that may occur on campus.

## Student Representation Fee

The Student Representation Fee is a \$1 per semester fee that students approved through a student body election. The student government (ASB) oversees and uses the fees to lobby and advocate for student issues and concerns at the state level. It also supports opportunities for students to attend leadership conferences on issues related to advocacy. Those students who do not wish to support these activities may request a refund directly from the ASB.

## Fee Status for Alien Residents

Undocumented aliens will be charged out-of-state tuition and fees unless eligible for resident tuition under AB540. See page 7 for details. Foreign students holding "F" visas are prohibited by federal law from establishing residency and will be assessed non-resident fees.

## Spring 2007 Fee Schedule

TOTALS INCLUDE: \$20 per unit Enrollment Fee, \$174 non-resident fee (if applicable), \$14 Health Fee (\$5 Summer Health Fee), \$1 per unit Campus Center Use Fee (maximum of \$5), \$6 Student Identification/Discount Card and \$1 Student Representation Fee.

<i>Number of Units</i>	<i>California Resident</i>	<i>Non Resident Out-of-State</i>	<i>Number of Units</i>	<i>California Resident</i>	<i>Non Resident Out-of-State</i>
0.5	31.5	118.50	9.5	216.	1869.
1	42.	216.	10	226.	1966.
1.5	52.50	313.50	10.5	236.	2063.
2	63.	411.	11	246.	2160.
2.5	73.50	508.50	11.5	256.	2257.
3	84.	606.	12	266.	2354.
3.5	94.5	703.50	12.5	276.	2451.
4	105.	801.	13	286.	2548.
4.5	115.5	898.50	13.5	296.	2645.
5	126.	996.	14	306.	2742.
5.5	136.	1093.	14.5	316.	2839.
6	146.	1190.	15	326.	2936.
6.5	156.	1287.	15.5	336.	3033.
7	166.	1384.	16	346.	3130.
7.5	176.	1481.	16.5	356.	3227.
8	186.	1578.	17	366.	3324.
8.5	196.	1675.	17.5	376.	3421.
9	206.	1772.	18	386.	3518.

## Courses With Additional Materials Fees

### Fees payable at Registration

<u>COURSE</u>	<u>DESCRIPTION</u>	<u>FEE</u>
AH 16	IV THERAPY	\$150.00
AH 32	BASIC CARDIAC LIFE SUPPORT	\$12.00
AH 43	INTERACTIVE & MENTAL HEALTH NURSING	\$100.00
AH 44	COMPENSATORY NSG	\$100.00
AH 62	MED-SURG NURSING	\$100.00
AH 64	MED-SUR/PEDI.NURSE	\$100.00
CD 160	CHILD CARE FIRST AID & CPR	\$12.00
CSIS 80	DIGITAL PHOTOGRAPHY	\$20.00
DM 80	DIGITAL PHOTOGRAPHY	\$20.00
GUID 1	SELF ASSESSMENT	\$12.00
PSYC 5	SELF ASSESSMENT	\$12.00

### Fees payable to instructor or additional materials required

<u>COURSE</u>	<u>DESCRIPTION</u>	<u>FEE</u>
COS 200	BEGINNING COSMETOLOGY cosmetology kit	\$500 (approx.)
COS 201	INTERMEDIATE COSMETOLOGY manikin, pedicure kit and uniform	\$250 (approx.)
COS 202-203	ADV COS - PRACTICUM manikin, uniform and books	\$300 (approx.)
MATH 404A-G	SELF-PACED BASIC MATH	\$60
PE 17	GOLF facility use fee - details at first meeting	\$TBA
PE 20	BOWLING	\$1.50 per session
PE 39	FENCING	\$6.00 (payable to instructor)

## Student Identification/Discount Card

The purchase of the Student ID/Discount Card benefits both the individual student and the college at large. The fees are budgeted by the Associated Student Body to develop and support campus activities, educational programs, speakers, and cultural events. Cardholders also receive numerous on and off campus benefits including:

- Free admissions to college athletic events
- Community wide discounts such as reduced movie admissions, restaurant discounts, gym discounts, etc.
- Free bluebooks and scantrons in the college bookstore

Students who do not wish to purchase the ID/Discount Card must decline the card in writing. Forms for requesting a waiver of this fee are available from the Admissions and Records Office, the Financial Aid Office, the Morgan Hill and Hollister sites, the ASB Office, and the ASB Advisor's office (located in the Counseling Department). These forms must be turned in at the time of registration. Requests for refunds must be processed through the ASB Advisor.

## Resident Enrollment Fees for Non-Immigrant Students (AB540)

AB540, as required by California law, provides an exemption from payment of non-resident tuition for non-immigrant students. To be eligible, a student must have attended a California high school for three full years and have graduated from a California high school or have received the equivalent of a California diploma (GED, CHESPE). The exemption does not grant residency status and the qualifying student may not be eligible for state aid programs such as BOG or EOPS or federal financial aid. The student must sign an affidavit affirming that he or she has filed or will file an application with INS to legalize his or her immigration status as soon as he or she is eligible to do so. Contact the Admissions & Records Office for more information.

## Dropped a class?

## Want a refund?

Gotta ask or it won't happen.

see page 6



# Paying for College

## APPLYING FOR FINANCIAL AID

*Financial assistance with college expenses is available for students of all incomes.*

### FINANCIAL AID OFFICE

Room SC 124 408-848-4727

Open: Mon. - Thurs.: 8 a.m. - 5 p.m., Fri.: 8 a.m. - 3 p.m.

Evening hours: Hours are extended during peak registration periods.

[www.gavilan.edu/finaid/](http://www.gavilan.edu/finaid/)

Gavilan College participates in several financial aid programs that are designed to provide assistance to students with documented financial need. This aid is provided from several sources: federal, state and private agencies.

### Requirements for Financial Aid Applicants:

Financial aid applicants:

- Must demonstrate need according to the guidelines of each program
- Must be a U.S. citizen or eligible non-citizen
- Must be in good standing on a federal student loan or not owe a refund of student financial aid
- Must demonstrate eligibility to benefit from higher education
- Males must be registered with Selective Service
- Must maintain satisfactory academic progress.

Note: If you have been convicted of illegal drug use or sales you may be ineligible for some aid programs.

#### SATISFACTORY ACADEMIC PROGRESS (SAP) POLICY

The Gavilan College Financial Aid Office is required to measure your academic progress toward a Certificate, Associate, or Transfer Degree program. If you are not pursuing one of these programs, you are not eligible for financial aid. Your progress will be reviewed at least once per academic year.

If you are disqualified due to poor academic history, you must attend a SAP Policy Workshop. Stop by the Financial Aid Office to sign up for the SAP Policy Workshop.

### What Financial Aid Applications do I complete?

**BOG Application:** For CA residents who meet income guidelines. If eligible, your enrollment fees are waived for an entire year: summer 06, fall 06, and spring 07 terms. Complete the 2006-07 BOG Application

**FAFSA (Free Application for Federal Student Aid):** Determines your eligibility for federal and state grants as well as the fee waiver if you do not meet BOG income guidelines and are a CA resident. The FAFSA can be completed through paper application or online at [www.fafsa.ed.gov](http://www.fafsa.ed.gov). Be sure to add the Gavilan school code of 001202 so that the Financial Aid Office can receive your processed FAFSA. Complete the:

- 2006-07 FAFSA: if you will attend summer '07 session
- 2007-08 FAFSA: if you will attend the fall '07, spring '08, &/or summer '08 terms

**Cal Grant Application:** For CA residents who meet various criteria, including income and GPA. The Cal Grant Application with a March 2nd, 2007 deadline determines your eligibility for Cal Grants A and B. Filing an 07-08 FAFSA is required for Cal Grant consideration.

**Scholarship Applications:** See the financial aid office for institutional scholarships and private scholarship information/materials.

Links to these applications are available online, through the Financial Aid Office webpage: [www.gavilan.edu/finaid/](http://www.gavilan.edu/finaid/)

### Financial Aid Programs

#### FEE WAIVER:

Board of Governor's Fee Waiver/BOG Program – waives mandatory enrollment fees for eligible students. This fee waiver is for students who are California residents. The BOG application is included on pages 9-10 of this schedule.

#### FEDERAL AND STATE GRANTS:

- Federal Pell Grant
- Federal SEO Grant
- Federal Work Study Grant
- Cal Grant (B and C)
- Chafee Grant
- Child Development Grant
- EOPS Grant
- TRIO Grant
- CARE Grant



## FEDERAL WORK-STUDY GRANT:

Provides the student with an opportunity to earn money while gaining valuable work experience and is awarded based on financial need.

## SCHOLARSHIPS:

Scholarships are awarded on the basis of academic achievement and/or financial need. Eligibility varies and is set by the scholarship donor. Gavilan College Educational Foundation Scholarship application is due March 2nd. Other private scholarship applications with various deadlines throughout the school year are available in the Financial Aid Office. See the Financial Aid website at [www.gavilan.edu/finaid](http://www.gavilan.edu/finaid). We recommend you inquire about scholarships several times per semester as new scholarships are announced throughout the academic year as they become available.

## VETERAN AFFAIRS BENEFITS:

Gavilan College offers special assistance to student veterans and children of disabled veterans. Students having questions pertaining to eligibility, benefits, application procedures and other veteran matters should contact the Financial Aid Office at 408-848-4727.

## SUBSIDIZED STAFFORD LOAN:

Gavilan College participates in the Federal Family Educational Loan Program. If you are interested in applying for a Subsidized Stafford Loan, complete the FAFSA & attend an Entrance Loan Counseling Session. Applications for the Subsidized Stafford Loan are distributed at Loan Counseling Sessions.

## LOOK US UP ONLINE AT [WWW.GAVILAN.EDU/FIN Aid/](http://WWW.GAVILAN.EDU/FIN Aid/)

Complete the FAFSA at [www.fafsa.ed.gov](http://www.fafsa.ed.gov)

Online financial planning guide & budget counseling at [www.edwise.org](http://www.edwise.org)

Check your Stafford loan status at [www.elmresources.com](http://www.elmresources.com)

Online loan counseling at [www.edfund.org](http://www.edfund.org)

Selective service verification of enrollment at [www.sss.gov](http://www.sss.gov)

## Ability to Benefit

### NEED FINANCIAL AID BUT HAVE NO HIGH SCHOOL DIPLOMA?

Federal regulations require students who do not have a high school diploma, General Educational Development (GED) certificate, or California High School Proficiency Exam (CHSPE) and who are applying for financial aid, to take an Ability to Benefit assessment. If you have a high school diploma (or equivalent) from another country you are exempt.

The Ability to Benefit ACT Asset schedule is listed below. To sign up for a session, call or come by the Financial Aid Office: 408-848-4727 (SC124).

### ASSET Testing Schedule for Native English Speakers:

DAY	DATE	TIME	LOC
Friday	Jan 5	9-11	Room TBA
Friday	Jan 19	1-3	Room TBA
Friday	Feb 2	9-11	Room TBA
Wednesday	Feb 21	1-3	Room TBA
Friday	Mar 2	8-10	Room TBA
Friday	Mar 16	1-3	Room TBA
Friday	Mar 30	10-1	Room TBA
Friday	Apr 13	1-3	Room TBA
Friday	Apr 27	8-10	Room TBA
Friday	May 4	8-11	Room TBA
Friday	May 18	1-3	Room TBA

Times and locations subject to change and additional times may be added. Confirm time and location with the Assessment Office in LS 114 - 408-846-4992 prior to testing date.

### CELSA (Combined English Language Skills Assessment)

Students with limited English language skills who are enrolled in English as a Second Language (ESL) classes and do not have a high school diploma or GED and are applying for Financial Aid must take the CELSA assessment.

Call the Financial Aid Office (SC124) at 408-848-4727 for a referral. Then call the Assessment Office (LS114) at 408-846-4992 to schedule your appointment.

## GO RAMS!

## Spring Sports



Men's Baseball

Women's Softball

Co-ed Golf

Men's Basketball

Students wishing to participate in the intercollegiate athletic programs must be enrolled in and attending a minimum of 12 units during the first season of competition with nine units applying towards a degree program.

For more information, contact the Athletic Department at 848-4876.

Also check out:

Aerobics  
Bowling  
Cardio Fitness  
Dance  
Pilates  
Self Defense  
Soccer  
Swimming  
Volleyball  
Yoga

Gavilan Joint Community College  
Board Of Governors Fee Waiver Application (BOG)

SUMMER 06, FALL 06, SPRING 07 SESSIONS/SEMESTERS

PENDING PROCESSING

REASON:

This is an application to have your enrollment fees waived. This FEE WAIVER is for California residents only.

**Note:** Students who are exempted from paying nonresident tuition under Education Code Section 68130.5 (AB 540) are NOT California residents. If you are NOT a California resident you are not eligible for this fee waiver. Please do not complete this application and do not complete the FAFSA. We encourage you to apply for private scholarships through: [www.fastweb.com](http://www.fastweb.com) and [www.maldef.org](http://www.maldef.org). See the Financial Aid Office for additional private scholarships which do not have permanent residency and citizenship requirements.

**Note:** If you are a US citizen or if you have Permanent Residency status through the Department of Homeland Security, we encourage you to apply for additional financial aid (for books, rent, transportation and other costs) by completing the FREE APPLICATION FOR FEDERAL STUDENT AID (FAFSA) immediately. Complete the 2005-06 FAFSA if you'll be attending the 2006 Summer session. Complete the 2006-07 FAFSA if you'll be in school for: Fall 2006, Spring 2007, and/or Summer 2007. Contact the Financial Aid Office for more information. **The FAFSA is available at [www.fafsa.ed.gov](http://www.fafsa.ed.gov) or at the Financial Aid Office.** Please finish completing this Fee Waiver Application.

Name: \_\_\_\_\_ SSN# \_\_\_\_\_  
Last First Middle Initial

Address: \_\_\_\_\_ Telephone: (\_\_\_\_) \_\_\_\_\_ - \_\_\_\_\_  
City Zip Code

Date of Birth: \_\_\_\_/\_\_\_\_/19\_\_\_\_

HAS THE ADMISSIONS OR THE REGISTRAR'S OFFICE DETERMINED THAT YOU ARE A CALIFORNIA RESIDENT?  YES  NO

IMPLEMENTATION OF THE CALIFORNIA DOMESTIC PARTNER RIGHTS AND RESPONSIBILITIES ACT

The California Domestic Partner Rights and Responsibilities Act extends new rights, benefits, responsibilities and obligations to individuals in domestic partnerships registered with the California Secretary of State under Section 297 of the Family Code. If you are in a Registered Domestic Partnership (RDP), you will be treated as an Independent married student to determine eligibility for this Fee Waiver and will need to provide income and household information for your domestic partner. If you are a dependent student and your parent is in a Registered Domestic Partnership, you will be treated the same as a student with married parents and income and household information will be required for the parent's domestic partner.

**Note: These new provisions apply to state funded student financial aid ONLY, and not to federal student financial aid.**

Are you or your parent in a Registered Domestic Partnership with the California Secretary of State under Section 297 of the Family Code? (Answer "Yes" if you or your parent are separated from a Registered Domestic Partner but have **NOT FILED** a Notice of Termination of Domestic Partnership with the California Secretary of State's Office.)  Yes  No  
If you answered "Yes" to the question above treat the Registered Domestic Partner as a spouse. You are required to include your domestic partner's income and household information or your parent's domestic partner's income and household information in Questions 3, 6, 7, 8, 9, 10, 11, 12.

Student Marital Status:  Single  Married  Divorced  Separated  Widowed  Registered Domestic Partnership

DEPENDENCY STATUS

1. Were you born before January 1, 1983?  Yes  No
2. As of today, are you married or in a Registered Domestic Partnership? (Answer "Yes" if you are separated but not divorced or have not filed a termination notice to dissolve partnership.)  Yes  No
3. Do you have children who receive more than half of their support from you, or other dependents who live with you (other than your children and spouse) who receive more than half of their support from you, now and through June 30, 2006?  Yes  No
4. Are you an orphan or a ward of the court, or were you a ward of the court until your 18th birthday?  Yes  No
5. Are you a veteran of the U.S. Armed Forces?  Yes  No
  - ♦ If you answered "Yes" to any of the questions 1 - 5, you are considered an INDEPENDENT student and must provide income and household information about yourself (and your spouse or RDP if applicable). Skip to Question #8.
  - ♦ If you answered "No" to all questions 1 - 5, complete the following questions:
6. If your parent(s) or his/her RDP filed or will file a 2004 U.S. Income Tax Return, were you, or will you be claimed on their tax return as an exemption by either or both of your parents?  Won't File  Yes  No
7. Do you live with one or both of your parent(s) and/or his/her RDP?  Yes  No
  - ♦ If you answered "No" to questions 1 - 5 and "Yes" to either question 6 or 7, you must provide income and household information about your PARENT(S)/RDP. Please answer questions for a DEPENDENT student in the sections that follow.
  - ♦ If you answered "No" or "Parent(s) won't file" to question 6, and "No" to question 7, you are a dependent student for all student aid except this fee waiver. You may answer questions as an INDEPENDENT student on the rest of this application, but please try to get your PARENT information and file a FAFSA so you may be considered for other student aid. You cannot get other student aid without your parent(s) information.

METHOD A

8. Are you (the student ONLY) currently receiving monthly cash assistance from:  
TANF/CalWORKs?  Yes  No  
SSI/SSP (Supplemental Security Income/State Supplemental Program)?  Yes  No  
General Assistance?  Yes  No
9. If you are a dependent student, are your parent(s)/RDP receiving monthly cash assistance from TANF/CalWORKs or SSI/SSP as a primary source of income?  Yes  No

♦ If you answered "Yes" to question 8 or 9 you are eligible for a FEE WAIVER. Sign the Certification at the end of this form. You are required to show current proof of benefits. Ask the Financial Aid Office for the FAFSA to be eligible for other financial aid opportunities.



**METHOD B**

- 10. **DEPENDENT STUDENT:** How many persons are in your parent(s) household? (Include yourself, your parent(s), and anyone who lives with your parent(s) and receives more than 50% of their support from your parents, now and through June 30, 2006.) \_\_\_\_\_
- 11. **INDEPENDENT STUDENT:** How many persons are in your household? (Include yourself, your spouse, and anyone who lives with you and receives more than 50% of their support from you, now and through June 30, 2006.) \_\_\_\_\_
- 12. **2004 Income Information**

a. Adjusted Gross Income (If 2005 U.S. Income Tax Return was filed, enter the amount from Form 1040, line 34; 1040A, line 21; 1040EZ, line 4 or Telefile, line I).	<b>DEPENDENT STUDENT: PARENT(S)/ RDP INCOME</b>	<b>INDEPENDENT STUDENT: STUDENT (&amp; SPOUSE'S/ RDP) INCOME</b>
b. All other income (Include <b>ALL money</b> earned in 2005 that is not included in line (a) above. Include TANF benefits, disability, Social Security, child support. Include Earned Income Credit (Form 1040 Line 65a, 1040A Line 41a or 1040EZ Line 8a) and Additional Child Tax Credit (Form 1040 Line 67 or 1040A Line 42) if applicable.	\$ _____	\$ _____
TOTAL Income for 2005 (Sum of a + b) _____	\$ _____	\$ _____

The Financial Aid Office will review your income and let you know if you qualify for a FEE WAIVER under Method B. If you do not qualify using this simple method, you should file a FAFSA.

**SPECIAL CLASSIFICATIONS**

- 13. Do you have certification from the California Department of Veterans Affairs or the National Guard Adjutant General that you are eligible for a dependent's fee waiver? Submit certification.  Yes  No
- 14. Are you eligible as a recipient of the Congressional Medal of Honor or as a child of a recipient, or a dependent of a victim of the September 11, 2001 terrorist attack? Submit documentation from the Department of Veterans Affairs or the CA Victim Compensation and Government Claims Board.  Yes  No
- 15. Are you eligible as a dependent of a deceased law enforcement/fire suppression personnel killed in the line of duty? Submit documentation from the public agency employer of record and income information.  Yes  No

**If you answered "Yes" to question 13, 14, or 15, you are eligible for a FEE WAIVER. Sign the Certification at the end of this form.**

**CERTIFICATION FOR ALL APPLICANTS: READ THIS STATEMENT AND SIGN BELOW**

I hereby swear or affirm, under penalty of perjury, that all information on this form is true and complete to the best of my knowledge. **If asked by an authorized official, I agree to provide proof of this information, which may include a copy of my and my spouse/registered domestic partner and/or my parent's/registered domestic partner's 2005 U.S. Income Tax Return(s).** I also realize that any false statement or failure to give proof when asked may be cause for the denial, reduction, withdrawal, and/or repayment of my waiver. I authorize release of information regarding this application between the college, the college district, and the Chancellor's Office of the California Community Colleges.

\_\_\_\_\_  
*Applicant's Signature* *Date* *Parent Signature (Dependent Students Only)* *Date*

FOR OFFICE USE ONLY				
<input type="checkbox"/> BOGFW-A A1 <input type="checkbox"/> TANF/CalWORKS A2 <input type="checkbox"/> SSI/SSP A3 <input type="checkbox"/> GA	<input type="checkbox"/> BOGFW-B <input type="checkbox"/> BOGFW-C-Must attach: FAFSA Calculator Verification ISIR pg 1 w/EFC OR SAR w/Gavilan school code.	A4 <input type="checkbox"/> Special Classification <input type="checkbox"/> Veteran Dependent <input type="checkbox"/> National Guard Dep <input type="checkbox"/> Medal of Honor/or <input type="checkbox"/> 9/11 Dependent <input type="checkbox"/> Dep. of deceased law enforcement/fire personnel	RDP <input type="checkbox"/> Student <input type="checkbox"/> Parent	<input type="checkbox"/> Not eligible due to: <input type="checkbox"/> Non CA resident <input type="checkbox"/> FAFSA EFC exceeds student budget
Comments: _____				
DID STUDENT COMPLETE 06-07 FAFSA: <input type="checkbox"/> YES <input type="checkbox"/> NO <span style="float: right;">COMMENTS: _____</span>				
Certified by: _____ Date: _____ <span style="float: right;"><input type="checkbox"/> Forward to appropriate staff for database.</span>				
ENTERED IN "2006-07" BOG DATABASE" by: <span style="margin-left: 50px;">Anabel: A-E: _____</span> <span style="margin-left: 50px;">Dena: F-M: _____</span> <span style="float: right;">Nick: N-Z: _____</span>				



# Matriculation

## ADMISSIONS • ASSESSMENT • ORIENTATION • COUNSELING • FOLLOW-UP

Matriculation is a series of services that Gavilan College commits to provide for you. The purpose is to help you identify your educational goals and successfully complete them.

**Exemptions:** Sometimes a student does not want to take advantage of the matriculation services. That is a right you have. In order to be exempt from assessment and orientation you:

- must have an AA degree or higher
- must have accumulated fewer than 12 units in transfer courses
- must be presently enrolled in fewer than six units
- must not plan to earn a certificate or degree
- must complete a waiver form at the Admissions & Records Office. (Doing this will prevent you from participating in priority/early registration.)

You still have the right to use the other matriculation services. We encourage you to do so.

## Assessment

Placement/assessment testing will help ensure that students are enrolled in courses that match their abilities in language and computational skills. Students must have completed the eighth grade to be eligible for assessment services. Placement scores, together with other indicators of a student's abilities, are used by counselors to recommend appropriate course placements. Register for the assessment at the Admissions & Records Office in the Student Center.

***The assessment instruments used by Gavilan College for general assessment, the College Tests for English Placement (CTEP) and the Mathematics Diagnostic Testing Project (MDTP), are administered in English and are not intended for applicants to the English as a Second Language (ESL) program.***

Sessions begin promptly at the stated time. Check in begins one half hour prior to starting time. No one will be admitted after the session has begun.

Assessment requires:

- Valid picture ID \*
- Social security number required for scoring of exam
- 2 - #2 pencils (no mechanical pencils)
- No pagers or cell phones allowed in the testing room
- No watches allowed in the testing room.

\* A valid picture ID includes a California Driver's License, California ID, Passport, Student Body Card, Military ID or Alien Registration Card. Contact the Assessment Office (LS114) or call 408-846-4992 if you do not have a valid ID.

### Re-Assessment Sessions:

Students who have previously taken the assessment test may re-test after 30 days. You may re-assess once per semester. Stop by the Assessment Office (LS114) or call 408-846-4992 to confirm dates, times and locations.

Re-Assessment requires a copy of the student's previous test scores (test scores can be obtained from the Counseling Secretary - SC108).

Times and locations are subject to change. Additional times may be added. (Confirm dates and locations with the Admissions and Records Office or check online posting at [www.gavilan.edu/assessment](http://www.gavilan.edu/assessment).)

## Orientation

Orientation is one of the components of matriculation. It provides new students with an overview of instructional programs, support services, facilities and general graduation requirements. Completion will help students avoid making course choices that might complicate and lengthen the time required to reach their educational goals.

Gavilan College offers an online orientation. Click on the Orientation link on the Gavilan homepage ([www.gavilan.edu](http://www.gavilan.edu)) to complete the orientation or contact the Counseling Office at 408-848-4723.

You may choose to not participate in orientation by completing a waiver form at the Admissions & Records Office. Doing this will prevent you from participating in priority (early) registration.

### ORIENTATIONS are completed online.

Click on the Orientation link on the Gavilan homepage - [www.gavilan.edu](http://www.gavilan.edu)

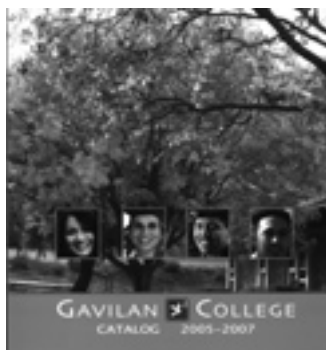

The College Catalog contains a complete description of all Gavilan College courses, student policies, and services. It can be purchased at the bookstore or viewed online at [www.gavilan.edu/catalog](http://www.gavilan.edu/catalog)

All new ESL students must go through the ESL assessment process. See page 32.

Todos los nuevos estudiantes de ESL deben tomar el examen de nivelación de ESL. Consulte la página 32.

# COUNSELING

Gavilan College provides a staff of full and part-time professional counselors to assist students in meeting educational, career and life goals. Counseling is available to students who are uncertain about their plans for the future, who are experiencing difficulty in making important decisions, or who have any other personal or social concerns. In addition, counselors make referrals to many community agencies. Students may seek the assistance of any counselor at Gavilan.

Photo ID required to obtain counseling services.

## Winter Intersession Counseling (counselors available for registration assistance only).

### Gavilan Main Campus (walk in):

Jan 3-4 & 8-11	8:00 am - 3:30 pm	<i>Counseling will be closed on Jan 5, 12 and 15</i>
Jan 16-19	8:00 am - 3:30 pm	
Jan 22-26	8:00 am - 3:30 pm	
Jan 29	8:00 am - 3:30 pm, 4:00-6:30 (by appt. ONLY after 4:00 pm)	

### Morgan Hill and Hollister sites (by appointment or drop-in):

Jan 9	Tu	11:00 am - 7:00 pm
Jan 10	W	11:00 am - 7:00 pm
Jan 23	Tu	11:00 am - 7:00 pm
Jan 24	W	11:00 am - 7:00 pm

Call 408-782-2873 for an appointment in Morgan Hill.  
Call 831-636-3783 for an appointment in Hollister.

## Spring Counseling

### Gavilan Main Campus (walk in and appointments):

Walk-in:	Mon-Fri	8:30 am-12:30 pm
Appointments:	Mon-Thur	8:00 am - 7:30 pm
	Fri	8:00 am - 3:30 pm

For more information call the Counseling Secretary: 408-848-4723.  
Counseling Office - SC 113 (in the Admissions building)

Morgan Hill site (by appointment): Phone 831-634-0917  
Hollister Briggs Building site (by appointment): Phone 408-782-0253

## Counselors by Department and Program

To schedule an appointment call the Counseling Secretary: 408-848-4723.  
Counseling Office - SC 113 (in the Student Center)

Dr. Rosa Sharboneau, <i>General Counseling/Transfer</i>	SC119
Dr. Tim Lister, <i>General Counseling</i>	SC106
Celia Marquez, <i>General Counseling/Puente Program</i>	SC105
Dr. Jesus Olivas, <i>General Counseling/Articulation</i>	SC104
Johanna Stewart, <i>General Counseling, ASB</i>	SC107b
Leslie Tenney, <i>General Counseling</i>	SC103
Candice Whitney, <i>General Counseling</i>	SC113
<b>Athletics:</b> Darlene Martin	848-4968 GY118
<b>DRC (Disability Resource Center):</b>	
Bruce Eastman	848-4865 LI117
Kelly O'Neill-Hinckley	848-4861 LI118
<b>EOPS/CalWORKS (Extended Opportunity Programs and Services):</b>	
Gary Cribb	848-4740 LI101a
Christina Garcia	848-4740 LI101a
<b>MESA:</b> Darlene Martin	848-4968 PH114
<b>TRIO:</b> Leticia Palacios	848-4707 SC161

# HIGH SCHOOL STUDENTS

## Concurrent Enrollment Procedures for High School Students

Students whose age or class level is equal to grades 9 - 12 may attend Gavilan College as part-time or summer session students for advanced scholastic, vocational, or physical educational courses in accordance with the following procedures:

A **Special Student Status Contract Form** is required prior to registering for classes. A new form must be completed each semester. The form is available in local high school counseling offices, from the Gavilan College Admissions & Records Office and is included in the center pages of this schedule. The form is also available online at [http://www.gavilan.cc.ca.us/admit/2003\\_hs\\_contract.pdf](http://www.gavilan.cc.ca.us/admit/2003_hs_contract.pdf)

Students enrolled in a public or private high school will be limited to a maximum of 6 units for fall or spring semesters and 5 during the summer term. Students in good standing, with a minimum 2.0 GPA, must submit a current transcript, complete the placement assessment, and have the written approval of a parent or legal guardian, a high school counselor or principal, and a Gavilan College counselor.

The campus center use fee, health fee, and student representation fee are waived for concurrently enrolled high school students.

## Your Gavilan College Counseling Appointment

High school students must review their completed contract with a Gavilan College counselor. Counseling Services are available at the Gavilan main campus. See counseling hours (left column) for dates and times.

Use the Registration Checklist (opposite) to prepare for your meeting. For more information, call the Counseling secretary: 408-848-4723. A photo ID is required to obtain counseling services.

High Step students are not required to see a Gavilan counselor. Please refer to steps for High Step students on page 14.

## High School students may co-enroll in the following:

All prerequisites and advisories apply

- Fall and Spring Semesters: **Transfer level (courses numbered 1-99)**
- Summer Session **All courses: Transfer and non-transfer level)**

All records of high school students attending Gavilan College are protected by the Federal Educational Rights and Privacy Act (FERPA) and may not be released to anyone without the written permission of the student.

## Need help buying books?

With an ASB card, you can apply for an ASB book loan (up to \$200) at the Financial Aid Office, Room SC124.

Buy an ASB card at the Admissions & Records Office, Room SC111.



## High School Students Concurrent Enrollment Registration Checklist

- #1 **Apply.** File a Gavilan College application at least 48 hours prior to registering for classes.
- #2 **Schedule and take an assessment placement test.** Sign up in person or call 408-848-4736.
- #3 **See your high school counselor.** Take your assessment test results and discuss possible courses. The course your counselor writes on the Special Student Status Contract Form is the course for which you will be enrolled, space permitting. Be sure the counselor signs your contract form. Directions to obtain the contract are listed in the concurrent enrollment section (page 12).
- #4 **Get a copy of your current high school transcript** from the Registrar at your high school and attach it to your contract form. The transcript must show that you are in good standing and that you have a grade point average of at least 2.00.
- #5 **Ask your parent or guardian to sign the contract.**
- #6 **Bring your transcript and signed contract** to a Gavilan College counselor during the enrollment period for high school students.
- #7 **Register for Gavilan classes.**
  - Enroll for a maximum of 6 semester units of transfer level courses during the fall and spring semesters or for 5 units of pre-collegiate or transfer courses during the summer term
  - Pay per unit enrollment fees only
  - Purchase a parking permit if you need one
  - Buy your books at the bookstore
- #8 **Enjoy your class!** You're earning college credit.

For more information, see the concurrent enrollment section (page 12).

### STUDENT

## Profile



#### **Kyle Fischer:**

I have wanted to be a game programmer for as long as I can remember and Gavilan has provided me the skills I need to obtain this career!

I found a mentor in Mr. VanTassel since the first computer programming course I signed up for at Gav the summer I graduated from 8th grade. I have taken continual classes year-round ever since, attending both high school and college at the same time. I earned Gavilan's Certificate of Programming Completion at 16.

Thanks to the knowledge I gained from these computer courses I was made the Web Master for my high school web site as well as Layout Editor for the school newspaper. I was able to graduate early from High School and will be finishing up my Associates degree in May 2007, enabling me at 18 to transfer as a Junior to a 4 year college. Gavilan has been great for me. I think if you know what you want to be or are just trying to find out, there are probably courses here that will help you get started.

P U E N T E

### Seniors! Plan ahead!

- Take the assessment and register by May!
- Placed in English 250 want to transfer? Puente may be for you.
- Learn about Mexican American/Latino Literature.
- College visits in Fall/Spring.
- Attend a Leadership Conference.
- Receive extra support from a community mentor.
- On-going academic, career and personal counseling until you transfer!

Meet with Puente Counselor/Coordinator Celia Marquez.  
Call 408-848-4723 to schedule an appointment.



## HIGH STEP Program High School Transfer Enrichment

Gavilan College, in conjunction with the Live Oak and Ann Sobrato High Schools in Morgan Hill and Gilroy High School will offer courses accepted at any university (such as Political Science/Government and US History 1 and 2) each spring and fall semester at the high school campuses. All students are required to take the placement assessment prior to enrolling. All concurrent enrollment documents are required. Please contact the Gavilan Assessment Office at 408-848-4992 or your high school counselor for more information and for a schedule of the placement assessment offered at the high school campuses.

### The Program:

- Start college while enrolled in High School!
- In two years earn a maximum of 12 college units.
- Courses conveniently offered at the high school.
- Meet college and university requirements while still in high school.

### The Benefits:

- Experience college level work.
- Reduce four-year university expense.
- Advance academically.
- Become competitive in the four-year college and university admission process.

### Who Can Participate?

- High School Juniors and Seniors.
- Minimum cumulative 2.0 GPA.
- Score at college level in reading, writing, and math.
- Ability to benefit from advanced scholastic work.

### Spring 2007 High Step offerings:

See the spring class listings for class descriptions.

#### Gilroy High School:

<b>sect. 4097</b>	<b>ART 14</b>	<b>Beginning Mural Painting</b>	
Gilroy (rm. H-3)	Wednesday & 2.3	3:15 pm - 7:20 pm	Dates: 1/31/07-5/23/07
<b>sect. 4802</b>	<b>PSYC 1A</b>	<b>Introduction to Psychology</b>	
Gilroy (rm. B-3)	Monday	3:10 pm - 6:20 pm	Dates: 2/5/07-5/21/07
<b>sect. 4787</b>	<b>POLS 1</b>	<b>Introduction to American Government</b>	
Gilroy (rm. B-E)	Tuesday	3:10 pm - 6:20 pm	Dates: 2/6/07-5/22/07

#### Live Oak High School:

<b>sect. 4883</b>	<b>CMUN 1A</b>	<b>Introduction to Public Speaking</b>	
Live Oak (rm. TBA)	Monday	3:30 pm - 6:40 pm	Dates: 2/5/07-5/21/07

#### Ann Sobrato High School:

<b>sect. 4062</b>	<b>AJ 10</b>	<b>Introduction to the Administration of Justice</b>	
Sobrato (rm. TBA)	Tuesday	3:30 pm - 6:30 pm	Dates: 2/6/07-5/22/07

Room assignments subject to change. Check online footnotes to confirm rooms.

## Course-to-Course Articulation Agreements\* for High School Students

### Gavilan College and District High Schools:

<u>High School Course</u>	<u>Gavilan College</u>	<u>Grade Criteria</u>
<b>Anzar High School - Aromas / San Juan Bautista</b>		
Algebra	Math 205	A or B
Advanced Algebra	Math 233	A or B

### Gilroy High School

Integrated Algebra 1 & 2	Math 205	A or B
Integrated Algebra 2 & 3	Math 233	A or B
Law Enforcement	AJ 10	A or B

### Live Oak High School - Morgan Hill

Computer Aided Drafting-ROP	CGD2 & CGD2R	C or better
Child Care-ROP	Child Develop. 1,21	A or B
Algebra I	Math 205	A or B
Algebra II	Math 233	A or B

### Mt. Madonna High School - Continuation High School Gilroy

Algebra I	Math 205	A or B
-----------	----------	--------

### San Benito High School - Hollister

Computer Aided Drafting-ROP	CGD2 & CGD2R	C or better
Careers with Children-ROP	Child Develop 21	A or B
Algebra 1A or Algebra II	Math 205	A or B
Algebra 2A	Math 233	A or B

\*Articulation agreements currently being reviewed. Check Admissions for further information

**High school contract students pay the per-unit enrollment fee. All credit earned is college credit.**

All records of high school students attending Gavilan are protected by the Federal Educational Rights and Privacy Act (FERPA) and may not be released to anyone without the written permission of the student.

## Recommended Math Course Placements For Area High School Students

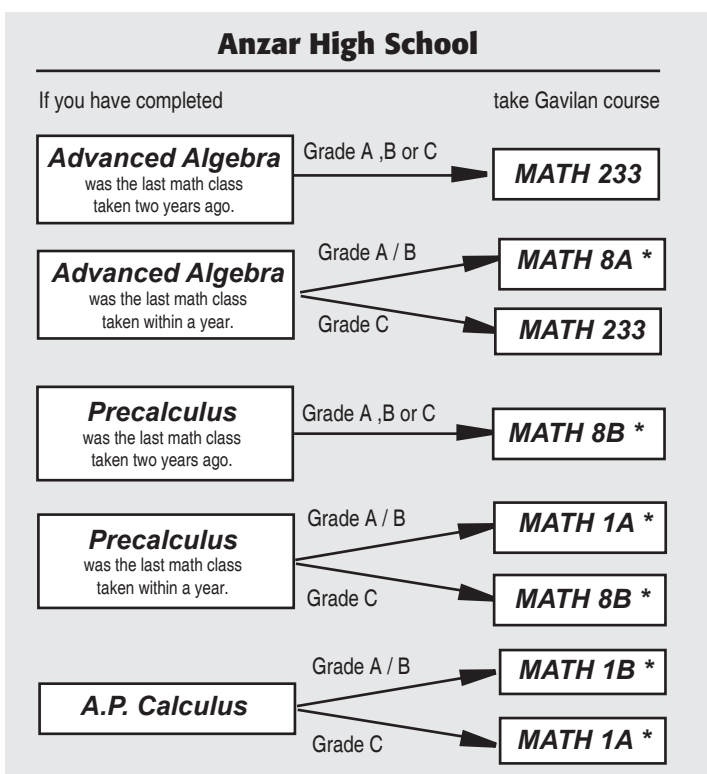
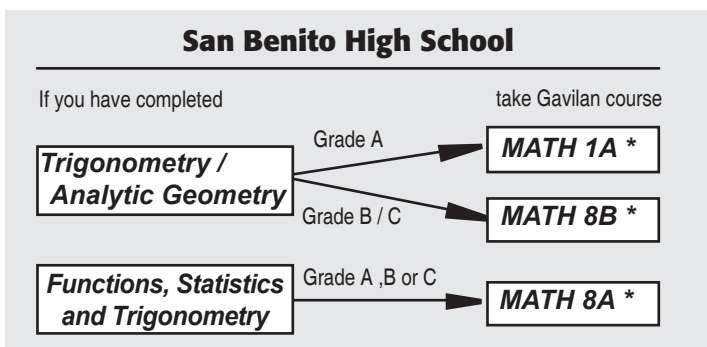
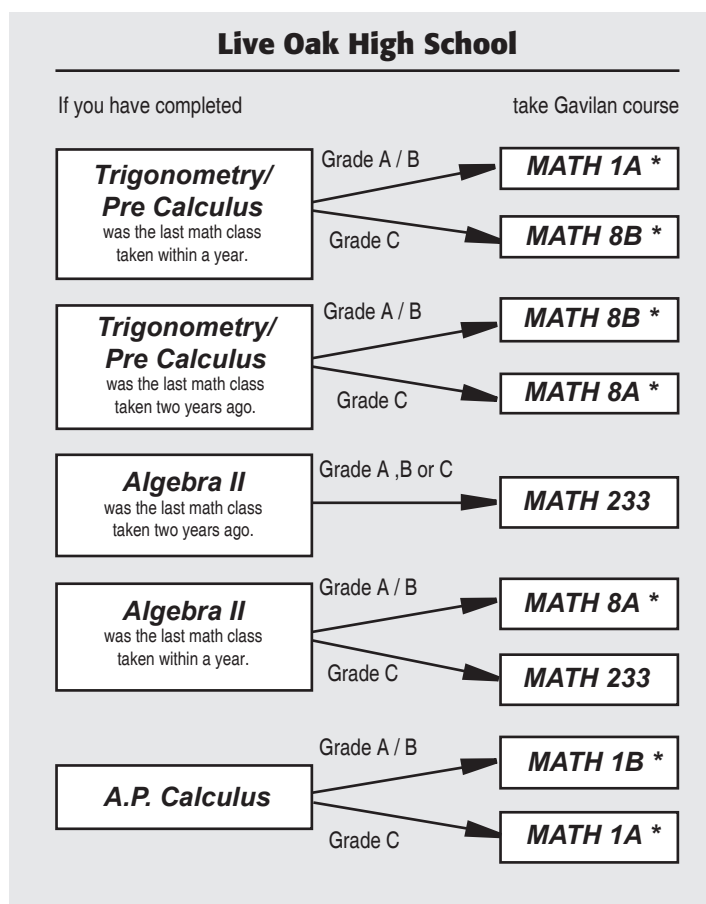
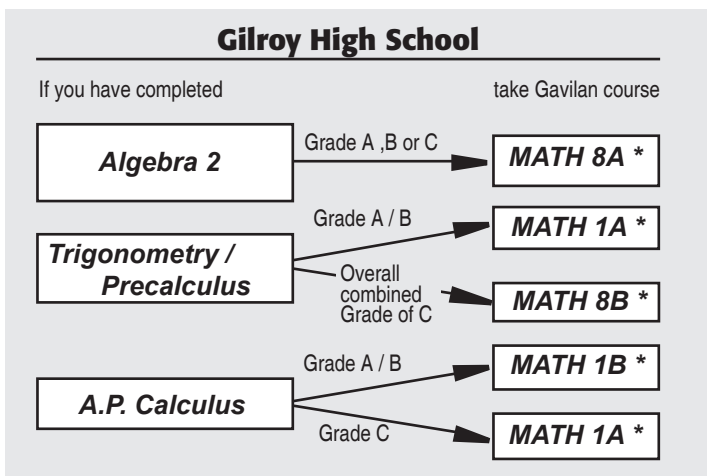

Multiple measures will be considered to determine your final course placement. Consult with a counselor to select the appropriate course.

\* Students eligible for these courses are also eligible for Math 5, 6, 7, 12 and 14.



## After School is Out TAKE a CLASS at GAVILAN!

Gavilan offers a selection of afternoon & evening classes at our three locations.

Receive college credit. Enroll for courses not available at high school.



# Transfer

## Complete your first two years of university coursework at Gavilan College.

Students planning to transfer to a four-year institution can generally complete the first two years of their college work at Gavilan College and enter the four-year institution with junior standing.

The requirements of universities vary. It is therefore advisable that students consult a counselor early in the semester for more detailed information about each university's specific requirements. *Due to recent changes in admissions policies at UCs and CSUs, working with a counselor is critical.*

### Transfer Credit

Official transcripts from institutions which are fully accredited by appropriate accrediting associations will be evaluated for transferable lower division coursework. Appropriate units and subject content will be applied to major and general education requirements to meet prerequisites or graduation requirements. Courses taken at other California Community Colleges, California State Universities or any University of California will be transferred to Gavilan with the same general education designation as that of the issuing institution.

Students who wish to transfer coursework from foreign institutions must submit official transcripts to a college-approved foreign evaluation service for translation and evaluation.

Coursework from a foreign institution cannot be used for certification to a four-year institution. Students should contact the institution to which they wish to transfer to inquire about the acceptance of foreign coursework.

### CLEP EXAMS

University of California does not grant credit for College Level Examination Program exams. CLEP credit CANNOT be used to certify IGETC. Some California State Universities will grant CLEP credit for certain areas and some will not grant credit at all. Transfer students are advised to contact the university they will be attending for specific information regarding CLEP credit.

### GENERAL EDUCATION RECIPROCITY AGREEMENT

The Gavilan Community College District has entered into a mutual agreement with seven other community Colleges to accept the general education of these colleges. The participating colleges are De Anza College (Cupertino), Evergreen Valley College (San Jose), Foothill College (Los Altos Hills), Gavilan College (Gilroy), Mission College (San Jose), Ohlone College (Fremont), San Jose City College (San Jose) and West Valley College (Saratoga).

Students who obtain a Certification of Completion of Associate Degree General Education or complete an associate degree at any of the participating colleges will have both their general education course work and graduation proficiencies accepted as completed at any one of the participating campuses.

### Courses Numbered 22, 23, 122, 123, 98, 198

These courses are also called "Independent Studies", "Special Studies", "Special Topics", "Internships", etc. Credit for variable topics courses is given only after a review of the scope and content of the course by the receiving institution. This usually occurs after transfer and may require recommendations from faculty. Check with a counselor to prevent surprises.

## Transfer Checklist

Are you preparing to transfer to a four year university? If so, planning now will guarantee a smooth and easy transition from Gavilan to the institution of your choice. Follow the recommended PLAN FOR SUCCESS:

### First Year at Gavilan:

#### FALL SEMESTER

- Meet with a counselor and inform him/her of your intent to transfer.
- Request a current copy of the general education pattern you wish to follow (IGETC or CSU)
- Refer to the Gavilan catalog for course descriptions.
- Begin to investigate possible major choices.
- Develop an educational plan with a counselor.
- Request that all high school and college transcripts be sent to Gavilan.

#### SPRING SEMESTER

- Meet with counselor to discuss academic progress and major choice.
- Update educational plan to include major preparation courses.
- Consider participating in student clubs, student government, etc.
- Identify at least 3 universities and check the required major preparation.
- Determine eligibility for an Associates Degree from Gavilan.

### Second Year at Gavilan:

#### FALL SEMESTER

- Meet with counselor to discuss course selections and to review educational plan.
- Verify completion of units, general education, and major preparation.
- Update educational plan, if necessary.
- Apply for scholarships and financial aid.
- Apply for college admissions.

#### SPRING SEMESTER

- Submit a Gavilan graduation petition.
- Read all of your correspondence from universities.
- Follow university instructions and meet deadlines.
- Keep copies of all correspondence
- Send official transcript showing work completed and courses in progress for spring.
- At the end of the semester, request two copies of your final transcripts (spring grades included) and a G.E. certification. One copy is sent to the university that you plan to attend and the second copy is for you to keep for your personal record.

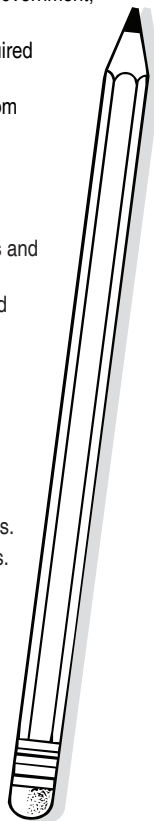

## Transfer Services

### ASSIST

ASSIST is a computerized student-transfer information system that can be accessed over the World Wide Web. It displays reports of how course credits earned at one California college or university can be applied when transferred to another. ASSIST provides the most accurate and up-to-date information available about student transfer in California. Visit the website at [www.assist.org](http://www.assist.org).

### CSU MENTOR

CSU Mentor is an online resource designed to help students and their families learn about the CSU system, select a CSU campus to attend, plan to finance higher education, and apply for admission. Personal data entered by the user is not released without the user's express consent and direction.

CSU Mentor is free to use. The student will only pay the application fee charged directly by the CSU campus when an application for admission is submitted.

Visit the website at [www.csumentor.org](http://www.csumentor.org).

### UC PATHWAYS

PATHWAYS, the University of California's online undergraduate admission information and application network.

- Information about financial aid and how to finance a UC education.
- Answers for Transfers
- UC campus Web sites, a list of links to the campuses for prospective students
- Transfer/Application Center
- Message Center - ask a question about undergraduate education or admission at UC

Visit the website at <http://www.ucop.edu/pathways>

## Transfer Agreements (TAAs)

A Transfer Admissions Agreement is a formal agreement between a student in attendance at Gavilan College and a receiving baccalaureate granting institution to which the student intends to transfer. The agreement guarantees admission to a transfer university a year in advance for the fall semester. It may also guarantee admission into a major.

Because the requirements of universities vary, it is advisable that students consult a counselor for more detailed information and to develop an educational plan.

Gavilan College has Transfer Admission Agreements with the following universities:

- UC Davis
- UC Merced
- UC Riverside
- UC Santa Cruz
- San Francisco State University
- San Jose State University
- University of Santa Clara
- CSU Monterey Bay

You do your part and they'll do theirs (admit you early!). Articulation agreements are also available online at [www.assist.org](http://www.assist.org). For eligibility requirements schedule a counseling appointment by calling 408-848-4723.

## Career/Transfer Resource Center

The center is located in SC102. Call 408-848-4818 for more information.

**Transfer Institute** See page 126.

# California Articulation Number System

The California Articulation Number (CAN) System provides a cross reference number for courses which have been evaluated by faculty and determined to be acceptable "in lieu of" each other. Only lower division, transferable, major preparation courses commonly taught on two- and four-year college and university campuses are included in the System.

The criteria for a campus to qualify to use a CAN Number includes written, faculty-approved articulation agreements on each course with a minimum of four public four-year California colleges and universities.

The CAN Number System is not a common numbering system. Each campus retains its own course numbers, prefixes and titles. The CAN (e.g., CAN ENGL 2) is listed parenthetically in catalog descriptions, class schedules and other publications as appropriate.

The CAN designation is assurance that the course or sequence of courses will be accepted in lieu of an identically designated CAN course or sequence at all participating campuses in California.

(CAN ENGL1A = CAN ENGL 1A at another college.)

## Visit the Career/Transfer Resource Center

**Services** are designed to assist you throughout your time at Gavilan College.

- ◆ Information on career outlook, training and educational opportunities
- ◆ Career Assessment using EUREKA and TRUE COLORS
- ◆ College Fair
- ◆ Transfer information
- ◆ Workshops
- ◆ Articulation agreements using ASSIST
- ◆ College and university catalogs
- ◆ Assistance with admission procedures and referral to academic counseling
- ◆ Library of career reference materials

Located in SC102, on the main campus  
For more information call 408-848-4818  
or visit the website at [www.gavilan.edu/transferctr](http://www.gavilan.edu/transferctr)

# 90 30

GAVILAN COLLEGE

and INDIANA UNIVERSITY

## IN A QUANDRY about how to earn your bachelor's degree?

You've thought about an **online** degree but worry about "diploma mills."

You love where you live and wouldn't **dream** of leaving.

You'd attend a four-year **college** but can't just pull up stakes.

You're earning your associate degree and want to go on for a **bachelor's**.

**Successfully complete** at least 30 of the 120 required hours/units through Indiana University.

### Sign up for the Independent

**Learner Online** Learn more about the General Studies Degree Program by signing up for the electronic newsletter, Independent Learner Online. To subscribe, send an e-mail to [gsd@indiana.edu](mailto:gsd@indiana.edu). Provide your name and e-mail address.

**Learn more.** Talk to your Gavilan College counselor. Call 408-848-4723 for an appointment. Call 1-800-334-1011 to talk directly to an IU staff member.

Visit <http://scs.indiana.edu/undergraddegrees/9030program.html>.

**Gavilan College and Indiana University** have joined forces so that you can earn a bachelor's degree from the nation's "**Hottest Big State School**"—without leaving home!

- ▲ Stay with your job, family, and friends in your home town.
- ▲ Pay Indiana in-state tuition.
- ▲ Start your bachelor's degree when your schedule permits, and work at your own pace.

### How 90 ► 30 Works

1. Earn 60 semester hours/units at your community college.
2. Apply for admission to IU. While you may apply to IU before earning an associate degree at Gavilan College, it is advisable to earn your degree before submitting your IU application.
3. Once admitted to IU, complete an additional 30 semester hours/units from Gavilan's curriculum.
4. Take your final 30 semester hours/units of upper-division courses via distance education at Indiana University, and join the thousands of students worldwide who have earned an IU Bachelor of General Studies.

### What is the Bachelor of General Studies?

The Indiana University School of Continuing Studies offers a Bachelor of General Studies that you can complete entirely at a distance. There are no oncampus residency requirements.

- ▲ Take online courses and/or correspondence courses.
- ▲ Pay the same tuition as Indiana residents – no matter where you live.
- ▲ Earn your bachelor's degree from a fully accredited, Big Ten university.

You must complete a minimum of 120 semester hours/units to earn the Bachelor of General Studies. You may transfer up to 90 semester hours/units toward your bachelor's degree, but you must successfully complete at least 30 of the 120 required hours/units through Indiana University.

As a general studies student, you pursue an interdisciplinary plan of study that encompasses arts and sciences:

- ▲ arts and humanities
- ▲ social and behavioral sciences
- ▲ mathematics and natural sciences

To graduate, you must have completed the required course work in these areas, plus an additional 66 semester hours/units of elective credit.

You interact with your IU instructors by e-mail, phone, fax, and postal mail, and receive academic counseling from experienced advisors who guide you through your course of study, as well as respond to your questions and concerns.

### Why Indiana University?

- ▲ Newsweek, AMERICA'S HOT COLLEGES 2006 identified Indiana University as the nation's "hottest big state school."
- ▲ Intel® named Indiana University the nation's top wireless university in 2004.
- ▲ Time magazine called Indiana University "College of the Year" in 2001.
- ▲ In 2002, 2003, 2004, and 2005, U.S. News & World Report recognized Indiana University programs designed to help freshmen succeed.

## Gavilan College Associate Degree Graduation Requirements

A Gavilan College Associate degree (AA or AS) is a combination of general education courses and a specific major selected from the Gavilan College catalog.

1. File a **Petition to Graduate** with the Admissions & Records Office by April 1 for a Spring or Summer graduation and October 1 to graduate at the end of Fall Semester. One petition must be filed for each Associate degree, Certificate of Completion, Certificate of Achievement or Award of Achievement the student expects to receive.
2. Students must earn an overall grade point average of 2.0 ("C") or higher for all work attempted and a grade of 2.0 "C" or higher in each major or certificate courses.
3. Complete a minimum of 18 units of coursework in a major. Specific major course requirements are listed in the college catalog.
4. Complete a minimum number of 60 semester units. Within the (60) unit requirement, the (9) units in Area A and B-4 must be completed with a grade of "C" or better in each course.
5. Complete the last 12 units, or a total of 48 units, at Gavilan College.

### Gavilan College AA/AS General Education Requirements (2006-2007)

Area	Semester Units
<p><b>A. COMMUNICATION IN THE ENGLISH LANGUAGE</b> <span style="float: right;"><b>6-9</b></span></p> <p>One course from each of these three areas:</p> <p><b>A-1 Oral Communication</b> – CMUN 1A, 5, 8 or 10</p> <p><b>A-2 Written Communication</b> – ENGL 1A or ENGL 250</p> <p><b>A-3 Reading</b> – ENGL 260 or SSCI 270A or SSCI 270 B with a grade of "C" or better, or demonstrate reading proficiency at the college level. (Competency may be verified by an approved test.)</p>	
<p><b>B. PHYSICAL UNIVERSE AND ITS LIFE FORMS</b> <span style="float: right;"><b>6-14</b></span></p> <p><b>The Physical or Life Science requirement will include at least one course that has a laboratory section.</b></p> <p>One course from each of these areas:</p> <p><b>B-1 Physical Science</b> – ASTR 1; <u>CHEM 1A, 1B, 12A, 12B, 30A, 30B</u>; <u>GEOG 1; GEOL 1, 13</u>; <u>PHYS 1, 2A, 2B, 4A, 4B, 4C</u>, PSCI 1, 2</p> <p><b>B-2 Life Science</b> – ANTH 1; <u>ECOL 1; BIO 1, 4, 5, 7, 8, 9, 10, 13, 15, 20</u></p> <p><b>B-3 Laboratory Activity</b> – Lab courses are underlined and are included in B-1 and B-2</p> <p><b>B-4 Mathematics</b> – Minimum of Math 205 or equivalent. (Competency may be verified by an approved test.)</p>	
<p><b>C. ARTS, FOREIGN LANGUAGE, LITERATURE AND PHILOSOPHY</b> <span style="float: right;"><b>5</b></span></p> <p>One course from each area:</p> <p><b>C-1 Fine and Performing Arts</b> – Art, Theatre Arts, Music (other than area 2); CMUN 2; HUM 10; Journalism (other than Journalism 10)</p> <p><b>C-2 Cultural History, Foreign Language, Philosophy</b> – ART 11; ART/HIST 21; ENGL 1B, 1C, 2A-F, 2H, 2I, 2J, 4A, 4B, 5A, 5B, 9A, 9B, 9C; HIST 1, 2, 3, 4A, 4B, 5, 6, 7A, 7B, 10, 12, 14, 18, 19; HUM 3, 4, 5, 10; JOUR/SOC 10; PHIL 1, 2, 3A, 3B, 4, 6A, 6B, 7A, 7B, 8, 15; any foreign language</p>	
<p><b>D. SOCIAL, POLITICAL, AND ECONOMIC INSTITUTIONS</b> <span style="float: right;"><b>9</b></span></p> <p>One course from area D-1, and two courses from area D-2:</p> <p><b>D-1 U.S. History and Political Institutions</b> (3 units) One course from HIST 1, 2, 5, 18, 19 or POLS 1</p> <p><b>D-2 Behavioral, Economic and Social Science</b> (6 units) Two courses from AJ 6, 10; ANTH 2, 3, 5, 8, 9, 10; General Business 1; CMUN 4; ECON 1, 2, 10; GEOG 2; HIST 1, 2, 3, 4A, 4B, 5, 6, 10, 12, 14, 18, 19; JOUR/SOC 10; POLS 1, 3, 4; AJ/CMUN/POLS/PSYC 6; POLS/PHIL 12; PSYC 1A, 1B; PSYC/CD 2, 3, 7; SOC 1A, 1B, 3, 4; SSCI 1</p>	
<p><b>E. LIFELONG UNDERSTANDING AND SELF-DEVELOPMENT</b> <span style="float: right;"><b>3</b></span></p> <p><b>E-1</b> One unit from any Physical Education activity class or Intercollegiate Sport *</p> <p><b>E-2</b> Minimum of two units from: AH 3, 30; AH/BIO 11; CSIS 1, 2, 6, 8, 45, 51; GUID 1/PSYC 5, GUID 6, 200; HE 1, 2; PHIL 3B, 6B, 8, 15; POLS/PSYC 27; PSYC/CD 2, 3; PSYC 41; SOC 21</p> <p>* Note: Some CSUs require two units of Physical Education, an additional unit is recommended.</p>	
<p><b>F. CULTURAL DIVERSITY</b> <span style="float: right;"><b>0-6</b></span></p> <p>Two courses from the following list; courses may also count under appropriate areas for other General Education requirements.</p> <p>AH 3, AH/BIO 11; ANTH 3, 5, 9, 10; ART 10A, 11, 20; ART/HIST 21; CD/PSYC 7; CMUN 4; ENGL 2B, 2E, 2H, 2I; GEOG 2; HIST 3, 5, 6, 10, 12; PHIL 6A, 15; POLS 3, 4; SOC 3; SPAN 9A, 12A, 12B; THEA 1</p>	

## Advanced Placement (AP)

Gavilan College grants up to six semester units of transfer credit for each College Board Advanced Placement (AP) Test on which a student receives a score of 3 or better. The AP results must be submitted to the Office of Admissions & Records with a request for evaluation.

Students receiving a score of 3, 4 or 5 on the Math and English AP exams will be exempted from the placement assessment test. AP units will not apply toward financial aid, nor can they be used to satisfy the residency unit requirement.

Advanced Placement credit will be awarded as follows:

Test	Score*	Equiv. Gav. College	Semester Units
American History	3,4,5	HIST 1,2	6
Art History	3,4,5	ART 1A, 1B	6
Biology	3,4,5	BIO 10	4
Chemistry	3,4	CHEM 30A	4
	5	CHEM 1A	5
Computer Science A	3,4,5	CSIS 45	3
Computer Science AB	3,4,5	CSIS 45,46	6
English Language & Composition	3,4,5	ENGL 1A	3
English Composition & Literature	3,4	ENGL 1A	3
English Composition & Literature	3,4	ENGL 1A	3
	5	ENGL 1A, 1B	6
(Max # Units in English= 6)			
Economics, Macro	3,4,5	ECON 1	3
Economics, Micro	3,4,5	ECON 2	3
Government & Politics:			
U.S.	3,4,5	POLS 1	3
Comparative	3,4,5	POLS 3	3
Math/Calc AB	3,4,5	MATH 1A	4
Math/Calc BC	3,4,5	MATH 1B	4
Math/Statistics	3,4,5	MATH 5	3
Music Theory	3,4,5	MUS 3A	3
Physics B	3,4,5	PHYS 2A	4
Physics C	3,4,5	PHYS 2B	4
Psychology	3,4,5	PSYC 1A	3
Spanish	3,4	SPAN 1B	5
	5	SPAN 2A	5

\* Scores of "3" may not be accepted for all courses by some 4 year colleges and universities.

## Articulation Agreements

Gavilan College has completed lower division course-to-course, major-to-major and general education agreements with all California State University (CSU), University of California (UC) and a number of private university campuses. These agreements ensure that participating universities will accept certain courses taken at Gavilan College to satisfy general education, major or elective university requirements.

The articulation officer, counselors and the Career/Transfer Resource Center staff have lists of participating institutions. Articulation agreements are also available online. See information on [www.assist.org](http://www.assist.org).

**Note: Educational plans for students preparing to transfer to any public or private institution can be developed.**

Please see your counselor for additional information and to view copies of specific transfer agreements. The Counseling Office is located in SC108. For more information call 408-848-4723.

## Intersegmental General Education Transfer Curriculum (IGETC)

The IGETC can be used by community college transfer students to fulfill lower division general education requirements for either the CSU or UC system without the need, after transfer, to take additional lower division general education courses, as long as your IGETC completion is certified at the community college. Obtain the Certification form from Admissions and Records.

**Students are strongly encouraged to complete all IGETC requirements prior to transfer.**

**PARTIAL IGETC** - If you are approaching readiness for transfer and, for good cause, are unable to complete one or two IGETC courses, you may be eligible to complete IGETC after transferring. Typical situations which constitute good causes for not completing one or two IGETC courses are illness, unavailable or cancelled courses, military service and unexpected hardships, such as family or employment problems, experienced in the final term before transfer.

If your petition for partial certification of IGETC is approved, you may be able to complete IGETC in one of the following ways:

- 1) Take a certified IGETC course, in the area to be completed, at any California community college, when you are not enrolled at a California State University or a University of California, such as during summer session.
- 2) Complete the requirement at a California community college while concurrently enrolled at UC or CSU. You will be subject to the UC or CSU campus rules regarding concurrent enrollment, so this option may not be available at your university campus.
- 3) Take a comparable course at the UC or CSU campus to which you will be transferring. This option is at the discretion of each campus, so it may not be a choice available to you.

You will be expected to complete IGETC before the beginning of the second full year of enrollment at your UC or CSU campus. Check with your campus advisor after you transfer for more information, including which options are available and which UC or CSU courses may be comparable to the IGETC courses remaining to be completed.

All UC and CSU campuses will accept IGETC with the exception of Fifth and Revelle Colleges at UC, San Diego. Since all majors are available at each of the five colleges at UC, San Diego, students will not be restricted in their choice of major if they use the IGETC.

A course cannot be used to satisfy more than one subject area of the IGETC (general education). However, major prerequisite courses can be used (double counted) to satisfy IGETC requirements.

CSU campuses' limitations on double counting of general education courses toward major preparations are not changed by IGETC.

Students who wish to be certified for both CSU and UC systems should take CMUN 1A, 8 or 10 in Area 1 for CSU and meet the foreign language requirement for UC. Completing both provides flexibility and choices.

The courses for all IGETC areas must be completed with a grade of "C" or better before IGETC can be certified. A grade of "C-" is not acceptable.

### See a counselor when you are:

- a first time student planning to transfer
- a first time student planning to obtain a AA/AS degree
- an undecided major
- a high school contract student
- an academic probation student
- taking over 17.99 units (spring/fall) or over 5.99 units (summer)
- have completed prerequisite courses at another college(s)
- an international student with an "F" Visa

## UC/CSU Intersegmental General Education Transfer Curriculum

### IGETC - 2006-2007

Completion of all the requirements in the IGETC will permit a student to transfer from a community college to the California State University or the University of California without the need, after transfer, to take additional lower-division general education courses to satisfy campus general education requirements. All areas must be satisfied and all courses must be completed with a grade of "C" or better before IGETC can be certified by Gavilan College's Admissions and Records Office. A "C-" is not acceptable. See the Gavilan catalog and a counselor for details. A student is strongly advised to complete a total of 60 transferable units before transferring. These will include the IGETC requirements, "major" prerequisites and elective units if needed.

*(Students should request an IGETC certification from the Office of Admissions & Records before transferring.)*

<p><b>AREA 1 – ENGLISH COMMUNICATION</b> <span style="float: right;"><b>9 units</b></span></p> <p><b>CSU</b> – Three courses required, one each from A, B and C  <b>UC</b> – Two courses required, one each from A and B  <b>A: English Composition</b> – ENGL 1A  <b>B: Critical Thinking</b> – ENGL 1C or PHIL 4  <b>C: Oral Communication</b> (CSU requirement only) – CMUN 1A, 5**, 8 or 10</p>
<p><b>AREA 2 – MATHEMATICAL CONCEPTS AND QUANTITATIVE REASONING</b> <span style="float: right;"><b>3 units</b></span></p> <p>One course: GBUS/ECON 11; MATH 1A, 1B, 1C, 2, 2C, 5, 6, 7, 8, 8A, 8B, 9<sup>o</sup>, 10<sup>o</sup>, 14; MATH/CSIS 26</p>
<p><b>AREA 3 – ARTS AND HUMANITIES</b> <span style="float: right;"><b>9 units</b></span></p> <p>Three courses, at least one in the Arts and one in Humanities  <b>Arts</b> – ART 1A, 1B, 6, 20; ART/HIST 21; MUS 1A, 1B; THEA 1, 3**, 7; HUM 6**  <b>Humanities</b> – ENGL 1B, 2A, 2B, 2C, 2D, 2E, 2H, 2I, 2J, 4A, 4B, 5A, 5B; HIST 1, 2, 3, 4A, 4B, 5, 6, 7A, 7B, 10, 12, 14, 18, 19; HUM 3, 4, 5, 10; PHIL 1, 3A, 3B, 6A, 6B, 7A, 7B, 8, 15; SPAN 2A, 2B</p>
<p><b>AREA 4 – SOCIAL AND BEHAVIORAL SCIENCES</b> <span style="float: right;"><b>9 units</b></span></p> <p>Three courses from at least two disciplines or an interdisciplinary sequence            ANTH 2, 3, 5, 10; CD/PSYC 2, 3; CMUN 4; ECON 1, 2, 10; GEOG 2; HIST 1, 2, 3, 4A, 4B, 5, 6, 10, 12, 14, 18, 19; JOUR/SOC 10; POLS 1, 3, 4; POLS/PHIL 12; PSYC 1A, 1B; SOC 1A, 1B, 3, 4; SSCI 1</p>
<p><b>AREA 5 – PHYSICAL AND BIOLOGICAL SCIENCES</b> <span style="float: right;"><b>7-9 units</b></span></p> <p>Two courses, (minimum of 7 units), one Physical Science course and one Biological Science course, one of which must include a lab (Lab courses are underlined)  <b>Physical Science</b> – ASTR 1; <u>CHEM 1A, 1B, 12A, 12B, 30A, 30B</u>; <u>GEOL1</u>; <u>GEOG1</u>; PSCI 1, 2**; <u>PHYS 1, 2A, 2B, 4A, 4B, 4C</u>  <b>Biological Sciences</b> – ANTH 1; <u>BIO 1, 4, 5, 7, 8, 9, 10, 13, 15</u>; <u>ECOL 1</u></p>
<p><b>Language other than English (UC requirement only)</b> – Complete two years of the same foreign language at high school level with a grade of "C" or better, <u>OR</u> earn a score of three or higher on the Foreign Language Advanced Placement exam <u>OR</u> complete up to the equivalent of SPAN 1B, JPN 1B** and FRNH 1B** or higher at Gavilan <u>OR</u> the equivalent at another college.</p>
<p><b>CSU Graduation Requirement in U.S. History, Constitution and American Ideals</b> – Not part of IGETC and you may NOT use the following courses to satisfy requirements for IGETC. (May be completed prior to transfer.)</p> <p>For the baccalaureate degree, one of the following combinations is required: HIST 1 &amp; 2, HIST 1 &amp; 19, HIST 2 &amp; 18; POLS 1 with either HIST 1, 2, 18 or 19.</p>
<p><b>Note: Transfer credit of certain courses (especially Science &amp; Math) may be limited by either UC or CSU or both. Consult with a counselor.</b></p> <p><b>Note:</b> University of California (UC) does not grant credit for College Level Examination Program (CLEP) exams. CLEP credit WILL NOT be used to certify IGETC. Some California State Universities (CSU) will grant credit for certain areas and some will not grant credit at all. Transfer students are advised to contact the university (CSU) they will be attending for specific information regarding CLEP credit.</p> <p>** Approved for fall, 2006            ☐ Approved retroactively for Fall, 1999</p> <p style="text-align: center;"><b>NOTE:</b> Courses listed under more than one discipline or area may be used only once to satisfy an area.</p>

## CSU General Education (Breadth) Requirements 2006-2007 certified by Gavilan College

Students transferring to the California State University system will qualify for admission as upper division transfers if they have completed 60 transferable units with a GPA of 2.0 ("C") or better (non-residents 2.4 or better). Within the 60 unit requirement, the 9 units in Area A (Communication), Area B-4 (Mathematics), and 18 additional semester units of general education coursework must be completed with a grade of 2.0 ("C") or better in each course.

Students who complete the following pattern will have satisfied the lower division General Education requirements for the California State University BA/BS degree. A minimum of 9 semester units of General Ed coursework must be completed at the upper division level after transfer; some CSU campuses require more than 9 units. See a counselor for further information.

Students completing the General Education Pattern below will not have to take any more lower division general education courses at the university provided they request a general education certification from the Office of Admissions and Records before transferring.

<p><b>AREA A – Communication in the English Language and Critical Thinking</b> <span style="float: right;"><b>9 units</b></span></p> <p>Select one course from each category. All courses must be completed with a grade of "C" or better.</p> <p><b>A-1 Oral Communication</b> – CMUN 1A, 5**, 8 or 10  <b>A-2 Written Communication</b> – ENGL 1A  <b>A-3 Critical Thinking</b> – PHIL 2, 4 or ENGL 1C</p>
<p><b>AREA B – Physical Universe and its Life Forms</b> <span style="float: right;"><b>9 units</b></span></p> <p>One course from each category. The Physical or Life Science course must include a laboratory.</p> <p><b>B-1 Physical Science</b> – ASTR 1; <u>CHEM 1A</u>, <u>1B</u>, <u>12A</u>, <u>12B</u>, <u>30A</u>, <u>30B</u>; <u>GEOG 1</u>; <u>GEOL 1</u>, 13; <u>PHYS 1</u>, <u>2A</u>, <u>2B</u>, <u>4A</u>, <u>4B</u>, <u>4C</u>; PSCI 1, 2**</p> <p><b>B-2 Life Science</b> – ANTH 1; <u>ECOL 1</u>; <u>BIO 1</u>, <u>4</u>, <u>5</u>, <u>7</u>, <u>8</u>, <u>9</u>, <u>10</u>, <u>13</u>, <u>15</u>, <u>20</u></p> <p><b>B-3 Laboratory Activity</b> – Lab courses are underlined and are included in B-1 and B-2</p> <p><b>B-4 Mathematics/Quantitative Reasoning</b> (Grade "C" or better) – GBUS/ECON 11, MATH 1A, 1B, 1C, 2, 2C, 5, 6, 7, 8, 8A, 8B, 9<sup>⊙</sup>, 10<sup>⊙</sup>, 12, 14; MATH/CSIS 26</p>
<p><b>AREA C – Arts, Literature, Philosophy and Foreign Language</b> <span style="float: right;"><b>9 units</b></span></p> <p>Required: <b>English 1B</b> and one course from C-1, and one course from C-2</p> <p><b>C-1 Arts – (Art, Dance, Music, Theatre)</b> - Minimum of 2 units from one of these courses – ART 1A, 1B, 2A, 3A, 6, 8A, 10A, 13, 14, 20; ART/CD 25A; ART/HIST 21; CMUN 2/THEA 4; HUM 6**, 10; MUS 1A, 1B, 3A, 4A; THEA 1, 3**, 7, 12A, 20**</p> <p><b>C-2 Humanities (Literature, Philosophy, Foreign Languages)</b> – ART 11; ART/HIST 21; ENGL 2A-F, 2H, 2I, 2J, 4A, 4B, 5A, 5B, 9A-C; Foreign Language: FRNH 1A**, 1B**, JPN 1A**<sup>⊙⊙</sup>, 1B**<sup>⊙⊙</sup>; SPAN 1A, 1B, 2A, 2B, 9A, 12A, 12B; HIST 1, 2, 3, 4A, 4B, 5, 6, 7A, 7B, 10, 12, 14, 18, 19; HUM 3, 4, 5, 10; JOUR /SOC10; PHIL 1, 3A, 3B, 6A, 6B, 7A, 7B, 8, 15</p>
<p><b>AREA D – Social, Political, and Economic Institutions</b> <span style="float: right;"><b>9 units</b></span></p> <p>Two requirements: select one course from Requirement 1, and 2 courses from Requirement 2.</p> <p><b>Requirement 1:</b> HIST 1, 2, 18, 19 or POLS 1 <b>Note:</b> For the baccalaureate degree, one of the following combinations is required: HIST 1 &amp; 2, HIST 1 &amp; 19, HIST 2 &amp; 18, POLS 1 with either HIST 1, 2 18 or 19.</p> <p><b>Requirement 2:</b></p> <p><b>D-1 Anthropology and Archeology</b> – ANTH 2, 3, 5, 8, 10  <b>D-2 Economics</b> – ECON 1, 2, 10  <b>D-3 Ethnic Studies</b> - CMUN 4; HIST 10, 12; SOC 3  <b>D-4 Gender Studies</b> – HIST 5, 6; SOC 4  <b>D-5 Geography</b> – GEOG 2  <b>D-6 History</b> – HIST 1, 2, 3, 4A, 4B, 5, 6, 10, 12, 14, 18, 19  <b>D-7 Interdisciplinary Social and Behavioral Science</b> – ANTH 9; CMUN 4; AJ/CMUN/POLS/PSYC 6; PSYC/CD 7; SSCI 1  <b>D-8 Political Science, Government, and Legal Institutions</b> – POLS 1, 3, 4; POLS/PHIL 12  <b>D-9 Psychology</b> – PSYC 1A, 1B; PSYC/CD 2, 3  <b>D-0 Sociology and Criminology</b> – SOC 1A, 1B, 3, 4; SOC/JOUR 10</p>
<p><b>AREA E – Lifelong Understanding and Self-Development</b> <span style="float: right;"><b>3 units</b></span></p> <p>1. Unit from any Physical Education activity course                  2. Two units from – AH 3; AH/BIO 11; GUID 6**; HE 1, 2; PSYC/CD 2 + 3 (acceptable for Area E only if taken in combination); PSYC 5/GUID 1; PSYC 41; SOC 21</p>
<p><b>Note: Transfer credit of certain courses (especially Science &amp; Math) may be limited by either UC or CSU or both. Consult with a counselor.</b></p> <p>** Approved for fall 2006                      ⊙ Approved retroactively for fall, 1999                      ⊙⊙ Approved retroactively for fall, 2005</p> <p style="text-align: right;">Courses listed under more than one discipline or area may be used only once to satisfy an area.</p>

# Student Life

## Associated Student Body (ASB)

The ASB is the official student organization on campus and provides the majority of student input and recommendations on critical campus issues to faculty, staff, administration and the Board of Trustees.

The **Student Senate** is a representative body of students who meet weekly to plan, implement and evaluate college activities and services that meet the needs of Gavilan College students. Any student who meets the requirements of the ASB's by-laws may become a voting member of the Student Senate. The elected and appointed officers provide a liaison between the students and academic departments and student services. The variety of leadership positions allows for different levels of involvement so that students can balance their academic and extracurricular loads effectively.

The political and practical leadership skills that students develop through the ASB are supplemented through a leadership course offered through the Political Science and Psychology Departments (POLS 27; PSYC 27). The curriculum includes practical skills that are applicable to college-related opportunities and other professional and personal environments. The curriculum is an interdisciplinary approach to contemporary leadership. This is an elective course that is transferrable to the CSU system and meets a GE requirement for the Gavilan College A.A./A.S. degree. Although the UC system does not accept the units for the class, it gives added consideration to those students who have been involved in student government and other college governance activities. Employers also look favorably upon a student's involvement in college leadership.

**ASB CARDS:** The benefits of buying a student body card are many. Revenue supports social and cultural activities on campus and provides the purchaser with discounts at athletic and cultural events and free bluebooks and scantrons (testing supplies) in the bookstore. Many businesses in Gilroy, Morgan Hill and Hollister offer discounts to card holders. Visit the ASB office in the Student Center - room 158 or call 408-848-4777.

## Publications

The **Gavilan Press**, an independent student newspaper, has provided students with a real world journalism experience and a public forum for their ideas and opinions since 1967. The newspaper covers events, issues and people that shape, reflect and define the college and the world. Call 408-848-4827 for more information.

The **Gavilan College Literary Journal** provides a forum for creative writers, helping to model and sustain the practice of writing poetry and prose. For more information call 408-846-4979.

## Rho Alpha Mu - Honor Society

Rho Alpha Mu is the Gavilan College chapter of Alpha Gamma Sigma, the California Community College Honor Scholarship Society. Its purpose is to recognize student scholarship, contribute to the social and cultural life of the campus and to provide and promote active involvement with the larger community through voluntary community service activities. Membership is open to all those with at least a 3.0 grade point average. There are a number of financial award possibilities for members in good standing. For more information call 408-846-4947.

## Theatre Productions

The **Monday Night Series** presents staged readings of new, controversial or unusual material free of charge at 6:30 Monday evenings in the Gavilan College Theatre. For more information call (408) 848-4860.

The **Summer Theatre Arts Repertory (STAR)** summer program trains children in dramatic performance. Students from the academic program serve as STAR leaders, often directing and producing plays for themselves. The Theatre program provides academic credit, production experience, and the opportunity for individual growth through the arts. For more information call 408-848-4764 or visit [www.gavilan.edu/star](http://www.gavilan.edu/star).

The **Gavilan College Theatre** offers a range of plays, including childrens' plays, musicals and Shakespearean productions. In addition to performing on stage, students learn backstage and technical production skills. For more information visit [www.gavilan.edu/theatre](http://www.gavilan.edu/theatre).



Part of the cast of Treasure Island

## ASB CLUBS

For more information call 408-848-4777.

Ambassadors  
A.S.B.  
Aneme  
Chi Sigma Lota  
(Administration of Justice)  
Cheerleading  
CDC Parenting Club  
COSMO  
Digital Media  
EOPS  
Gavilan Music  
Health Promotion  
GavTV  
International Club  
Latina Leadership Network  
Literary Club  
MANO (Men's Academic Network Organization)  
MESA (Math Engineering Science Achievement)  
Multicultural Club (TRIO)  
OUT  
Parent's Club  
Rho Alpha Mu  
TADA/Theatre Arts  
Teachers For Tomorrow  
The Gavilan Press/Student Newspaper



A variety of clubs and organizations have been established to provide opportunities for students to participate in scholastic, social, political, cultural and recreational pursuits. Club activities are coordinated and supported through the Student Senate. Students are encouraged to start clubs if they have a particular interest not represented currently on campus.



# General Information

## Attendance

Students who fail to attend the first class session may be dropped by the instructor. Generally, students missing one more class hour than the unit value for that course, without making prior arrangements, may be dropped without the possibility of credit. However, a student should not assume that he or she will be dropped by the instructor; it is the responsibility of the student to make sure that courses are officially dropped.

## Advisorles

Course advisory is recommended preparation for a course. It is not a prerequisite to taking a course but is strongly suggested that the advisory be met prior to enrollment as success in the course may depend upon having that skill or knowledge level. For example, a course advisory that reads "to be eligible for English 250 and English 260 in order to enroll in Psychology 1A" strongly recommends that you have successfully completed (with a "C" grade or better or a "credit") the previous courses, English 440 and English 260. This becomes critical in being able to read and understand college textbooks.

## Campus Safety and Crime Statistics

Contact the Gavilan College Security Dept. at 408-710-7490 (or dial "10" from any campus extension) to report criminal or potential criminal activity. For non-emergency calls, you may call the security office at 408-848-4703.

Campus safety information and crime statistics are available online at [www.gavilan.edu/safety](http://www.gavilan.edu/safety). If you would like a hard copy of this information, copies are available at Admissions and Records (SC111) and the Campus Security office (S/M bldg.) or call 408-848-4703 to have a copy mailed to you.

## Course Repetition

There are limitations on the number of times a student may repeat a course. All courses listed in this publication with no repeat notation following the description may be repeated only once if a grade of D, F, or NC was earned. A student may petition to repeat a course beyond the limitations listed providing there are extenuating circumstances such as verified cases of accidents, illness, or other circumstances beyond the control of the student or because there has been a significant lapse of time (3 years or more) since the student previously took the course.

To repeat a course in which the student has received a final grade of "C" or better a student files a Request to Repeat a Course Under Special Circumstances prior to registering for the course again. Units and grade points for the repeated course are not computed in the grade point average in this version of course repetition.

## Credit/No Credit, Letter Grade Option

For some courses, students have the option of selecting a final grade of Credit/No Credit or a traditional letter grade of "A", "B", "C", etc. Review the course description in this schedule to determine which courses are designated as having this option.

Before selecting a grading option, students should consider the following:

- Once the option has been selected, the student's decision is final and irreversible.
- To select one option over another, a student must complete the Grading Option form and file it with the Admissions & Records Office prior to the NRS (No Record Shown) date for the course. This date is either the end of the fourth week (for a

semester-long course) or 30% of the course meetings (for a short-term course.)

- If the student opts for a Cr/NC final grade, the units are not included in the semester GPA but are considered for the purposes of academic and progress probation and dismissal.
- A Cr/NC grade is not used in consideration of honors.
- A total of 20 units of Cr/NC graded units (not including those courses required by the major which are designated Cr/NC only) may be applied to an Associates's Degree or Certificate.
- The student should carefully consider the transferability of Cr/NC units to other institutions. Some universities may not accept any credit/no credit courses and others limit the amount of credit/no credit units that will be accepted. Please consult your counselor before selecting the credit/no credit option.

## Prerequisites and Co-requisites

A prerequisite is a course or skill level that is required before you can enroll in another particular course. For example, English 250 is a prerequisite for English 1A. Courses used to meet prerequisite requirements must have been completed with a "C" grade or better or "credit".

A co-requisite is a set of courses that you must take at the same time. For example, Math 209 is a co-requisite for Math 9.

If you believe that you have the equivalency of the prerequisite through another means (courses at another college, AP tests, work experience, etc.) speak with your counselor.

## CHALLENGING A PREREQUISITE

Students who believe that they have already fulfilled a prerequisite, or that a prerequisite has been improperly established or implemented, may challenge the prerequisite. The student is responsible for providing compelling evidence to substantiate the challenge based on one of the following:

- The prerequisite course has not been made reasonably available.
- The prerequisite was established in violation of regulation or in violation of the District-approved processes.
- The prerequisite is in violation of this Article.
- The prerequisite is discriminatory or is applied in a discriminatory manner.
- The student has the knowledge or ability to succeed in the course despite not meeting the prerequisite.

Challenge forms are available in the Admissions & Records Office or from a counselor and must be completed and returned to the Vice President of Instruction prior to the first day of classes.

## Transcripts

Transcripts of a student's permanent academic record are released ONLY with written authorization of the student. Telephone requests will not be accepted. The first two copies are free; there is a \$4 charge for each copy thereafter. Transcripts are normally sent out within five days of the request. This response time may be longer during busy periods such as the first two weeks of a new semester. Urgent requests cannot be honored during the late registration period but can normally be produced within an hour at a cost of \$7 per copy.

## DISCRIMINATION / HARASSMENT COMPLAINTS

Call Equal Opportunity Officer at 408-848-4715.

# Policies and Procedures

## Academic Freedom

It shall be the policy of the College to maintain and encourage full freedom for its faculty to teach, research and pursue knowledge subject to the applicable provisions of law.

In the exercise of this freedom the faculty member may, as provided in the U.S. and California Constitutions and other applicable laws, discuss his/her own subject or area of competence in the classroom, as well as any other relevant matters, including controversial matters, so long as he/she distinguishes between personal opinions and factual information.

Faculty shall be free from unlawful harassment or from unlawful interference or restrictions based on political views.

Faculty shall be free from any and all forms of electronic or other listening or recording devices, except with his/her express and non-continuing consent, except where allowed otherwise by law.

The Board shall not unlawfully inquire into, nor predicate any adverse action upon a faculty member's personal, political or organizational activities or preferences.

The Board shall not interfere with a faculty member's freedom of speech or use of materials in any teaching assignment, except as allowed by law.

The intent is to allow those activities protected by constitutional freedom of speech and other forms of academic freedom protected by the laws of the State of California and the laws of the United States.

## Open Enrollment

Unless specifically exempted by statute, every course, course section or class, the average daily attendance of which is to be reported for state aid shall be fully open to enrollment and participation by any person who has been admitted to the college and who meets all prerequisites. Class enrollment is limited by size of facility and program content. Gavilan College is in compliance with Section 504 of the Rehabilitation Act of 1973 and the Americans with Disabilities Act of 1990.

## American's With Disabilities Act (ADA) Compliance

If you have a verified disability and need academic materials in an alternate format or other services, contact the Disability Resource Center or the Vice President of Instruction and Student Services for assistance.

## Resources for Students with Disabilities

Students requiring academic or physical accommodations because of visual, physical, learning and/or other verified disabilities should contact the Disability Resource Center at 408-848-4865.

## Prohibition of Harassment and Hate Crimes

Reference: Education Code sections 212.5; 66252; 66281.5

The District is committed to providing an academic and work environment that respects the dignity of individuals and groups. The District shall be free of sexual harassment and all forms of sexual intimidation and exploitation. It shall also be free of other unlawful harassment and hate crimes, including those which are based on any of the following statuses; race, color, religion, ancestry, national origin, disability, sex (i.e., gender), sexual orientation, or the perception that a person has one or more of the foregoing characteristics.

## Non-Discrimination

The district is committed to equal opportunity in educational programs, employment, and all access to institutional programs and activities.

## Sexual Assault

Sexual assault is a crime regardless of when or where it occurs, or what the relationship is between the attacker and the victim. Gavilan College is committed to providing a safe environment for students and staff. Reports of sexual misconduct will be thoroughly investigated and the victim informed of the outcome.

If you, or someone you know, have been the victim of sexual assault, notify Campus Security 848-4703 or 710-7490. Confidential counseling is available on campus through Counseling 848-4723 or Student Health Services 848-4791.

Off campus confidential counseling is available at Community Solutions: (408)779-2115 and (831) 637-SAFE : (831) 637-7233.

## Title VI, Title IX, and ADA/Section 504/508

To file complaints in the following areas please contact the Equal Opportunity Officer, Joseph D. Keeler, Vice President of Administrative Services, HR101 (408-848-4715) or Shairon Williams, Director of Human Resources, HR103 (408-848-4753).

The areas are:

- Civil rights complaints (Title VI)
- Gender equity, sex discrimination/harassment complaints (Title IX)
- Persons with disabilities discrimination complaints (ADA/Section 504/508)

## Vocational English Skills

Limited English language skills will not be a barrier to admission to and participation in vocational education programs.

### Gavilan's Grade Policy

Grade	Grade Points	Definition
A	4	Excellent
A-	3.7	Excellent
B+	3.3	Good
B	3	Good
B-	2.7	Good
C+	2.3	Satisfactory
C	2	Satisfactory
D	1	Passing, Less Than Satisfactory
F	0	Failing
CR*	0	Credit - at least satisfactory, units awarded not counted in grade point average or in consideration of honors.
NC*	0	No Credit - less than satisfactory or failing, units not counted in grade point average.
I	0	Incomplete - incomplete academic work for unforeseeable, emergency and justifiable reasons after the last day to withdraw with a "w". Request for this grade must be initiated by the student. Work to be completed must not involve further class attendance or instruction. The Incomplete must be made up during the next term of attendance, summer excluded, within the next year.
W	0	Withdrew - withdrew from class after the NRS (No Record Shown) period and before the W deadline. Students withdrawing from courses after the W deadline must be awarded a letter grade or, if appropriate, request an incomplete (see above.)
MW	0	Military Withdrawal

\* To be used ONLY if final grade for a course is designated Credit/No Credit

## Drug Free Schools and Campuses Act

District Policy AP 3550 prohibits "the use, distribution, sale or possession of alcohol, narcotics, dangerous or illegal drugs or other controlled substances, as defined in California statutes, on District property or at any function sponsored by the District." Gavilan College complies with the Drug-Free Schools and Campuses Act of 1989 and the Drug-Free Workplace Act of 1988.

The college recognizes the legal drinking age of 21 years and enforces all state laws regulating the use of alcoholic beverages. All members of the campus community are subject to disciplinary action and/or criminal prosecution for the on-campus possession, use, sale or distribution (by either sale or gift) of any quantity of inappropriate prescription drugs, or controlled substances as defined by the State of California Health and Safety Code. Students found to be in violation of this policy may be subject to the Standards of Student Conduct and Discipline Procedures. If warranted, employees will also be subject to disciplinary sanction.

### For Free Confidential Assistance:

On-Campus:

- Counseling Center, 408-848-4723
- Student Health Services, 408-848-4791

Off-Campus:

- Alcoholics Anonymous, 408-374-8511; [www.AASanJose.org](http://www.AASanJose.org)
- Narcotics Anonymous, 408-998-4200
- National Council on Alcoholism & Drug Dependence 408-292-7292

Further detailed information on the risks associated with the use of alcohol and other drugs may be obtained from the Gavilan College website: [www.gavilan.edu](http://www.gavilan.edu). Click on Drug Free Schools and Campus Act of 1989 and the Drug Free Workplace Act of 1988.

### Health Consequences:

- Impaired learning due to poor concentration, fatigue, drowsiness, anxiety, altered perception, confusion, indifference, depersonalization, memory loss, panic attacks and drug-induced psychosis.
- Impaired judgment leading to driving under the influence of alcohol/other drugs, accidents, violent and abusive behavior, criminal acts, financial troubles, unwanted pregnancy, sexually transmitted diseases, acquaintance rape, attempted or accomplished suicide, permanent injury or death as a result of substance overdose.
- The use of intravenous drugs can result in hepatitis, tetanus, abscesses, and AIDS.
- The use of stimulants can lead to cardiac fibrillation, heart attack, seizures, respiratory arrest and death.
- The most common negative health consequences from occasional drinking are trauma incidents such as auto accidents and violent behavior which involve both the drinker and non-drinking victims.
- Long-term alcohol abuse can cause brain damage, cirrhosis of the liver, hepatitis, permanent coordination loss, ulcer disease, gastritis, pancreatitis, heart disease, stroke, anemia, sexual dysfunction, cancers and many other health problems.

### Legal Sanctions:

As a student, if you are under the influence of alcohol and/or other drugs, or if you are discovered selling or dispensing drugs on campus or at any college function, you can be suspended, expelled and criminally prosecuted.

If you are an employee at Gavilan College, you may be placed on probation, terminated and criminally prosecuted for the use, sale or possession of illegal drugs and/or alcohol on campus, or at college sponsored events.

For a first offense of driving under the influence of alcohol and/or drugs, you may serve 96 hours to six months in jail and pay a fine. It is unlawful for anyone with a blood alcohol content (BAC) level of .08 percent or above to drive a motor vehicle or ride a bicycle on a highway. For pot or marijuana (1 oz. or less), you can be fined up to \$100 and receive a criminal citation.

- For possession of marijuana (more than 1 oz.) you may receive up to 6 months in county jail, up to a \$500 fine, or both.
- For possession of cocaine you can be imprisoned in a state prison.
- For sales of any illegal drug you can be imprisoned in a state prison.
- Any person under the age of 21 years who has any alcoholic beverage in his or her possession on any street or highway or in any public place can be convicted of a misdemeanor.
- It is a misdemeanor crime to sell, give or furnish alcohol to anyone under 21 years of age.
- Carriers of motor vehicle insurance can increase premiums, cancel or deny renewal as a result of driving-under-the-influence convictions.

## Family Educational Rights and Privacy

In compliance with the Federal Family Education Rights and Privacy Act of 1974 (also known as the Buckley Amendment) and California Title V regulations (SB 182), Gavilan has adopted the following policy:

- Official academic, discipline and other necessary records are maintained on all students who have applied to attend Gavilan College.
- These records are maintained by and in the Admissions & Records Office and the Office of the Vice President of Student Services.
- These records will be released only upon the written authorization of the student upon payment of any or all fees and charges due the college, except as provided by law. Unless otherwise directed, the following directory of information may be released by Gavilan without written consent of the student:
  - name of the student
  - dates of attendance at Gavilan
  - date of graduation and degree or certificate awarded

Students who do not wish to have the above information released as directory information may notify the Admissions & Records Office in writing within the first week of each term. Copies of the complete federal and state regulations are available in the Vice President of Student Services Office and may be reviewed by students by appointment.

## Parking on Campus

Permits are available during all registration periods. All vehicles parked on the main campus are required to display a parking permit. Day permits are available from coin-operated machines located in parking lots A, E and at the south entrance to campus. Student parking is permitted in Lots A, C, E or H except where restricted to staff, guests, or the disabled. Parking Lot D is reserved for staff and disabled only. Guest parking permits are issued at the switchboard in Administration building. Disability parking is available in all lots to those displaying a placard from the Department of Motor Vehicles.

Student and staff parking is enforced by the campus security department and local law enforcement: Mon - Thurs: 7am-10 p.m and Fri: 7 am- 5 pm. All other spaces and areas are enforced at all times. A complete list of parking regulations is available at the main switchboard/reception area and outside the security office.

## Smoke-Free Buildings (BP 6500)

Smoking is prohibited inside all public buildings, within twenty five feet of all entrances/exits, operable windows or ventilation air intake. Smoking is also prohibited in all college-owned vehicles. Tobacco products shall not be sold on campus either through vending machines or campus establishments. Implementation of the campus smoke-free environment policy will be the responsibility of every student, faculty member, staff person and visitor on campus.

## Students' Problem Resolution Process

Procedures have been adopted to allow for student grievances against Gavilan staff members. The formal policy is available in the lobby of the Admissions Office, in the college catalog and on the Gavilan College website, [www.gavilan.edu](http://www.gavilan.edu). Students are encouraged to resolve issues informally by talking with college staff members.

# Student Services

## CalWORKs

CalWORKs helps students who receive public assistance to become self-sufficient through the provision of education, employment and supportive services. The program is administered through the Extended Opportunity Programs and Services (EOPS) Department for those who are currently receiving cash assistance. The occupational programs for CalWORKs students are linked to the demands of the local labor market and can assist students with a career track that will lead to a family-supporting income. The support services that CalWORKs provides include academic, personal and career counseling, textbooks, employment assistance and job placement and liaison with county departments of social services.

The EOPS/CalWORKs staff is friendly and supportive and will work with students to help them reach their goals. The office is located in L101 A & B, next to the library and is open Monday through Friday, 8 a.m. to 5 p.m. Interested students may call 408-848-4813.

## CARE

The Cooperative Agencies Resources for Education (CARE) is a special program designed to assist single parents who attend or would like to attend Gavilan College. CARE is a joint effort among the Department of Social Services, EOPS and Gavilan College. To be eligible for CARE, a student must be at least 18 years of age, head of household single parent/grandparent receiving cash assistance from the Department of Social Services, have at least one child under 14 years of age and be eligible for EOPS.

Services provided include:

Transfer and vocational education and counseling • Priority registration • Academic tutoring • Financial assistance with transportation, books, supplies, grants • Other support services

For additional information, call 408-848-4790 or visit the EOPS office located in L101 A & B.

## Career/Transfer Resource Center See ad on page 17.

## Child Development Center/Preschool

The Child Development Center provides care for preschool children in two state-funded programs for families whose monthly income meets eligibility criteria. In addition, a fee based preschool program is available to all parents. These programs serve children with disabilities and special needs as well as children who are limited or non-English speaking. The Center is the only facility in Gilroy that is accredited by the National Association for the Education of Young Children (NAEYC)

The Center is located above parking lot C and is open Monday - Friday. For more information, call 408-848-4815.

The Gavilan Community College district assumes no liability for loss of damage of student personal property.

## Disability Resource Center (DRC)

DRC provides a variety of services and classes in an effort to equalize educational opportunities for students with disabilities as they move toward their educational or vocational goals.

Services include:

Note taking • Academic, Career and Personal Counseling • Referral Services • Learning Skills Assessment • Vocational Classes • Academic and Educational Tutoring • Registration Assistance • Mobility Assistance • Vocational Aptitude Testing • Multi-media Educational Aids • Sign Language Interpreting • Job Training and Placement • Accommodations • Alternate Media Services

### DRC CLASSES OFFERED:

#### Guidance Courses:

Guid 530	Job Readiness
Guid 557	Learning Skills Assessment
Guid 558	Learning Skills Laboratory
Guid 560	Individualized Basic Skills Development
Guid 561	Writing Skills
Guid 562	Directed Study Lab in Arithmetic
Guid 563A/B	Directed Study Lab in Algebra
Guid 564	Directed Study Lab in Pre-Algebra

#### Adapted Physical Education:

PE 34/534	Adapted Aquatic Exercise
PE 35/535	Adapted Swimming for Total Fitness
PE 36/536	Adapted Physical Education
PE 38/538	Adapted Cardiovascular Conditioning and Training

#### Computer Science Classes:

CSIS 570	Computer Access Evaluation
CSIS 571	Computer Assisted Instruction
CSIS 572	Adaptive Computer Basics

**Vocational Preparation:** These programs are offered at three sites: Gavilan College, HOPE in Gilroy and HOPE in Hollister.

Students requiring accommodations or arrangements because of hearing, visual, or other disabilities should contact their instructor, counselor, or the Adapted Services Specialist at the Disability Resource Center located in LI 117. For more information call 408-848-4865.



## Health Insurance for students

Affordable year-round insurance is now available for community college students enrolled in a minimum of 6 units!

**\$100 deductible per year** (Visit Gavilan College's Health Nurse for a referral and the deductible is lowered to only \$50 per year!)

### Visit the doctor of your choice

**Benefits include:** hospitalization, emergency room visits, surgery, doctor's visits, treatment for mental and nervous conditions, prescription drug coverage, toll-free Nurse Advice Line.

For more information call 1-800-853-5899 or visit [somerton-inc.com/cclc](http://somerton-inc.com/cclc)

Sponsored by the Community College League of California

## Extended Opportunity Programs & Services (EOPS)

Extended Opportunity Programs and Services provides access and support services for low-income students facing social, economic and educational challenges.

The EOPS Program services include:

**Counseling:** Academic, career and vocational counseling • Personal problem-solving and crisis intervention • Vocational interest testing • Four-year college transfer assistance • Field trips to major four-year colleges • Community agency and emergency referrals

**Financial Assistance:** grants • book vouchers

**Specialized Workshops** for facilitating student success

**Other Services:** student computer center • one-on-one tutoring • book lending service • priority registration

The EOPS office is located in L101 A & B in the library and is open Monday through Friday, 8 a.m. to 5 p.m. Students who are interested may call 408-848-4740.

## First-Year Experience

Gavilan College offers a program for “first-time,” new students who want to strengthen their reading, writing and study skills while at the same time becoming familiar with the campus and its resources. Teachers and counselors work together to help students develop connections between the courses and their college experience. The goal is to help students build a strong foundation and place them on the road for college success. See class listings on page 58.

## Health Services

Gavilan College provides a full-time college nurse who provides health services, health information, health counseling and referrals.

Students receive confidential, personal health counseling for a variety of health concerns. Health Services provides first aid treatment, blood pressure screening, tuberculin skin testing for work/study students, HIV testing referrals, condoms and over-the-counter medications such as aspirin. Pamphlets and classes are available on nutrition, hepatitis, stress management, AIDS and other health topics provided in small group settings. Referrals for health conditions including alcohol and drug intervention are available. Health Services provides first aid kits throughout the campus and at the satellite sites, responds as a member of a team to campus emergencies on the main campus and provides information regarding outside health insurance for the college student.

Health Services is a comprehensive “one stop” center for a variety of health services located in the Admissions Building (SC 118.) Services are free and available Monday - Friday on the main campus in Gilroy. For additional information call 408-848-4791.

## Outreach and Recruitment Services

The services of the Outreach and Recruitment Office are designed to familiarize the community with the variety of programs and services available at Gavilan College. We will schedule tours of the campus or visits to a specific department, or provide information on academic, vocational and transfer opportunities. Outreach and Recruitment will also arrange for representatives from Gavilan to make presentations at your school or event.

For further information or to schedule a workshop, presentation or tour, please contact Outreach Services at outreach@gavilan.edu or call (408) 846-4993. Office location: BU 125.

## Puente

The mission of the Puente Program is to increase the number of educationally underserved students who plan to transfer to four-year colleges and universities, earn degrees and return to the community as leaders and mentors to future generations. Puente is open to all students.

**English Instruction:** Puente students take two consecutive writing classes, English 250 (Practical Writing) and English 1A (Composition). These classes provide a supportive and stimulating environment for Puente students to build confidence in their writing skills through an exploration of the Mexican American/Latino experience.

**Counseling:** Puente students work closely with their Puente counselor until they graduate, exploring career options, developing an academic educational plan and identifying lifetime goals. Students visit University of California and California State University campuses and attend an annual Puente student transfer conference.

All Puente students are also required to enroll in Guidance 6 (Life Skills for Higher Education) and Guidance 1 (Self-Assessment and Career Development).

**Mentors:** Each Puente student is matched with a mentor from the business or professional community. Mentors share with students their personal, academic and career experiences, and provide a window into “real-life” work environments. The network of trained Puente mentors provides many resources for the Puente students, their families, their colleges and their communities. If you are interested in more information please visit SC 105 or call 408-848-4807.

## Student-to-Student Mediation

Mediation services will provide students with an opportunity to problem-solve together in a safe environment. Trained student mediators will work with two or more students who are in conflict to reach mutually agreeable solutions. Mediation services are free and confidential.

Students wishing to become mediators can register for Introduction to Conflict Resolution (Psychology 6).

To obtain mediation services, contact the Counseling Department at 408-848-4723.

**Transfer Services** See Career/Transfer Resource Center ad - page 17.

## TRIO Student Support Services

The TRIO Student Support Services Program is funded by the Department of Education to specifically identify and support students who fit one of the following criteria: “first generation” college students, low income or students with verified disabilities. TRIO provides additional services such as academic counseling, tutoring, technology access, learning communities, cultural and social activities, and university visits.

TRIO is committed to increasing students’ success in math and English courses and creating a “sense of place” for those who sometimes feel isolated and disconnected during their college experience. If you are interested in more information please visit the TRIO Program in the Student Center (SC 160 & 161), or call 408-848-4707.

## Veteran Affairs Benefits

Gavilan College recognizes credit and grants credit to veterans and reservists for service and training completed in the Armed Forces. Gavilan College reports as credit for prior training only those prior units that are required for the student’s current objective at Gavilan College. Students having questions pertaining to eligibility for benefits, application procedures and other veteran matters should contact the Veteran Affairs official in the Financial Aid Office (SC124) or call 408-848-4727.

# Instructional Support & Labs

## Bookstore

Visit the Gavilan Bookstore on the Gilroy main campus early. Used books may be available at reduced cost. See ad on page 65.

## Computer Place

The Computer Place is a student service that supports student learning and academic success. Services provided include internet and email access, word processing, Spanish support software, scanning, free printing in black and white, minimal charge for color printing and transparencies. For more information, call 408-848-4729 or visit the lab in the Library (L168) Monday - Thursday, 8:00 am - 5 pm and Friday, 8:00 am to 2:00 pm.

## English as a Second Language (ESL) Computer Lab

The ESL Program has its own dedicated computer lab with a variety of software programs for all levels and classes. Students, at their convenience, practice and enhance language learned in class. The ESL lab is located in the Business Building (BU119.) Call 408-848-4856 for more information.

## Learning Communities

In learning community courses, you work and study with others so you'll be more successful in the course. Also, by linking two or more courses together, you'll begin to see greater connections between the disciplines. Research shows that when you take a learning community course, you become a stronger student and do better in your other college courses.

## Library

The Gavilan College Library delivers an array of print and electronic resources to the college community. Augmenting the 60,000 title printed book collection are 9,000+ e-books, and over 2,500 magazine titles, many available online in electronic databases. The Library staff prides itself on being a leader in information literacy projects and web-based instruction and has received several state grants supporting that effort. The Library faculty also teaches various courses on internet use, and works in tandem with other faculty in planning and revising courses with an information literacy component.

The Library homepage at [www.gavilan.edu/library/](http://www.gavilan.edu/library/) provides an online catalog of our book collection, links to various class websites and key online resources. The Library is open from Monday-Thursday, from 8:00 am - 6:00 pm and Friday from 8:00 am - 2:00 pm. For more information call 848-4810 (Circulation) or 848-4806 (Reference.)

## Math Lab

The math lab provides a place for students to practice math skills and receive individualized help with math problems at every level, from Basic Mathematics to Calculus. Students can work with math instructors, the math lab assistant or other students. Computers in the lab provide tutorial software as well as math software for Geometry, Statistics and Calculus projects. The Math Lab is located in the Physical Science Building (PH 101.) To download the daily schedule or for free math downloads, visit the website at <http://gavilan.edu/mathlab/>. For more information, call 408-848-4959.



Students learn better when they learn together!

In learning community courses, you work and study with others so you'll be more successful in the course. By linking two or more courses together, you'll see greater connections between the disciplines. Research shows that when you take a learning community course, you become a stronger student and do better in your other college courses.

## FIRST YEAR EXPERIENCE: Bridging Worlds and Navigating Frontiers

ENGL 250	Practical Writing
ENGL 260	Preparation for College Reading
GUID 1	Self-Assessment and Career Development

Four cohorts of classes will be offered. See page 87 to see which option best fits your schedule.

## CHILD DEVELOPMENT/ENGLISH: Playing with Learning: Understanding how kids grow.

Strengthen your reading and writing skills while studying children's development.

ENGL 250	Practical Writing
CD or PSYC 2	Early Child Development

See page 71 for details.

## ENGLISH: Speak Up! Speak Out! Voices at Home, in School and in the World

ENGL 420	Reading Improvement
ENGL 440	Basic Writing

Four cohorts of classes will be offered. See page 88 to see which option best fits your schedule.

## PUENTE: Focus on Mexican American/Latino literature.

ENGL 1A	Composition
GUID 1	Self-Assessment and Career Development

See page 84 for details.

## MATH: Close Encounters with Math and Science

MATH 233	Intermediate Algebra
MATH 201B	Math for Science & Engineering

or

MATH 205	Elementary Algebra
MATH 201A	Math for Science & Engineering

See page 100 for details.

## MESA

The MESA (Mathematics, Engineering, and Science Achievement) Undergraduate Program is a partnership between the University of California (UC) and California Community College Chancellor's Office. The program provides services to qualified students who are 1) majoring in math-based fields (i.e. CHEM, CSIS, ENGR), and 2) planning to transfer to 4-year universities in order to graduate with baccalaureate degrees and have financial need and are first generation college students. Open to all eligible students, MESA emphasizes participation by educationally underserved students. MESA provides a study center, Academic Excellence Workshops, tutoring, university trips, academic advising, workshops and more. The MESA Study Center is located in PH 105 - [www.gavilan.edu/mesa](http://www.gavilan.edu/mesa). For more information call 408-846-4968.

## Reading Lab

The Reading Lab supports the needs of students in reading classes with a special emphasis upon the English as a Second Language (ESL) classes. For more information, call 408-846-4980 or visit the lab in the Library (LI200a.) The lab is open Monday through Thursday 8:00 am - 3:00 pm; Friday 8:00 am - 12:00 pm.

## **LIBRARY DATABASES** <http://www.gavilan.edu/library>



Access Science  
CINAHL  
Country Watch  
CQ Encyclopedia of American Government  
CQ Historic Documents Series Online  
CQ Public Affairs Collection  
CQ Researcher  
Enciclopedia Universal en Espanol  
Encyclopedia Britannica  
Ethnic NewsWatch  
Literature Resource Center  
NetLibrary EBooks  
ProQuest Newspapers  
ProQuest Nursing Journals  
ProQuest Research Library  
RAND California  
Westlaw Campus Research

## **GET YOUR LIBRARY CARD NOW!**

Your library card gives you access to Library resources:

- Access to computers in the Library.
- Books, Ebooks, Reserve Materials and more.
- Access to all electronic databases, on campus or from home.

You can get your card in the library during our open hours. Library cards are available to registered Gavilan students, staff and faculty, as well as community residents with a valid photo identification.

## Transfer Institute

The Transfer Institute (TI) is a selective program designed for students who want to transfer to a public or private university in two years. Recent high school graduates who are academically prepared for college level work and students with placement in college level English and math are eligible.

The Transfer Institute will guide the student through the transfer process in the most efficient and effective means possible.

As a part of the Transfer Institute students will save time and money by completing the freshman and sophomore years at Gavilan College. Students will also meet and get to know other students who share their goals and ambitions.

Transfer Institute students receive:

- early registration
- a dedicated counselor to guide and monitor you through the transfer process
- pre-transfer events and activities with four-year universities
- access to activities designed to ensure your success at Gavilan College
- assistance with the identification of and preparation for a college major
- a two-year agreement guaranteeing transfer goals

A Transfer Institute application is on page 127 of this schedule of classes. Contact the Counseling Department at 408-848-4723 for more information.

## Tutoring Center

The Tutoring Center is a place where students with diverse academic needs gather together to receive learning assistance. The basic philosophy of the Tutoring Center is to assist students in the improvement of their learning skills and understanding of course content. This is accomplished by providing students with an opportunity to discuss processes and concepts, share ideas, give examples and practice, and summarize their findings in a collaborative environment. The goal of the Tutoring Center is to guide students to independent learning.

Day and evening tutoring services are free to all Gavilan College students. The Tutoring Center is located in the Library (LI 116.) Call 408-848-4838 for more information.

## Writing Center

The Gavilan College Writing Center fosters, celebrates and encourages writers.

Specially trained student assistants help writers start and strengthen class assignments as well as poetry, short stories, song lyrics, business letters and resumes.

The center offers space for writing discussions, meetings, workshops and study groups. Special events include activities with acclaimed writers from our Visiting Writers and Scholars in Residence programs. The center collaborates with faculty to increase the likelihood of students' academic success, providing links to assignments and effective research and writing strategies.

Call 408-848-4811 or drop by the center in the Library (LI 120) for information about scheduling. The center is open Monday - Wednesday, 8 a.m. - 6 p.m., Thursday, 8 a.m. - 8 p.m. and Friday, 8 a.m. - 1 p.m. (closed Thursdays from 2:30 - 4:30 p.m.)

# HOW TO USE THIS SCHEDULE

**Course Number**      **Course Title Description**      **Discipline**

**Prerequisites**      **BUSINESS, GENERAL**

*(Refer to the College Catalog for Advisories for most courses. See pages 24 of this schedule for an explanation of Advisories, Prerequisites and Co-requisites.)*

**Transferable**  
Includes:  
CSU, UC  
CSU-GE area designation  
IGETC area designation  
Gavilan AA/AS General Education designation  
CAN #: For more information, refer to the General Education/Course Credit Matrix on page 47 of the 2005-2007 Gavilan College Catalog.

**Section Number**      **Building/Room**      **Instructor**      **Semester Units**      **Class Hours per week**      **Footnotes**

**Evening & weekend Courses**  
*Listed in gray shade*

**Instructional Type**  
LEC Lecture  
LAB Laboratory  
L/L Lecture/Laboratory  
TV Telecourse  
CAI Computer Aided Instruction (online)

Sect.	Type	Room	Instructor	Hrs.	Units	Days	Begin-End	Ftnotes
0301	LEC	BU120	SMART	3.00	3.0	TuTh	0810A 0925A	
2118	LEC	BU119	STAFF	3.00	3.0	Th	0700P 0950P	1

**Footnotes**  
*Footnotes are listed following the courses*

## Schedule Legend

M	Monday
Tu	Tuesday
W	Wednesday
Th	Thursday
F	Friday
S	Saturday
Sun	Sunday
DHR	Daily Hours Required
&	Additional hours
&2	and 2 extra hours
FEX	Field Experience
TBA	to be arranged
CAI	Computer aided instruction (online)
TV	Telecourse
WEX	Work Experience
■	Gray shading indicates evening and weekend classes

## On-Campus Buildings

AL	Art Lecture
APE	Adaptive Physical Education
AR	Art
BOB	Business Offices
BU	Business
CD	Child Development Ctr.
CH	Chemistry
CHP	Chapel
CJ	Classrooms
CO	Cosmetology
GY	Gym
HOB	Health Occupations Bldg.
HR	Human Resources
HRC	Human Resources Conference Room
HU	Humanities
LI	Library
LS	Life Science
MAY	Mayock House
OE	Classrooms
PA	Police Academy
PH	Physical Science
SC	Student Center
S/M	Security/Maintenance
SS	Social Science
TH	Theatre

## Off-Campus Buildings

ANZ	Anzar High School, San Juan Bautista
AV	Aviation, Hollister Airport
COGMH	City of Gilroy (main hall, 7371 Hanna St.)
COGMR	City of Gilroy (meeting room)
GHR1	Gilroy Health Care and Rehabilitation, 8170 Murray Ave.
GHS	Gilroy High School
HARDIN	R. O. Hardin School in Hollister
HHH1	Hazel Hawkins Hospital 911 Sunset Drive Hollister, CA 95023
HOL	Hollister Briggs Bldg.
HOPE-G	Hope at Gilroy
HOPE-H	Hope at Hollister
HOLLCC	Hollister Comm. Center (Jovenes de Antano), 300 West St., Hollister
HVME1	Hacienda Valley Mobile Estates, 275 Burnett Ave., Morgan Hill
LOADCS	Live Oak Adult Day Care Services, 651 W. 6th St., Gilroy
LOHS	Live Oak High School
MHG	Morgan Hill Community & Cultural Center
OMC	Ochoa Migrant Camp
PHM1	Pacific Hills Manor 370 Noble Court Morgan Hill, CA 95037
PLY	Morgan Hill Playhouse, Monterey Highway and Dunne, Morgan Hill
RANCHO	Rancho Park Apartments, 1200 Rancho Drive, Hollister
SB	San Benito High School
SBCL	San Benito County Library, 470 5th St., Hollister, 95023
S.BRAT	Sobrato High School, Morgan Hill
SOBRTO	Sobrato Transitional Housing, Gilroy
SOLB7	Solorsano Middle School, Gilroy, room B-7
STFI	St. Francis, 7950 Church St., Gilroy, 95020
SV001-004	South Valley Middle School, Building I, 385 IOOF Ave., Gilroy
SVALLY	South Valley High School
VET	Veterans' Memorial Bldg., 649 San Benito St., Hollister
VG1	Village Green, 1520 Hecker Pass, Gilroy
VPRH	Valley Pines Retirement Home, 545 E. Main Ave., Morgan Hill, 95037
WEX	Work Experience
WM	Wheeler Manor, 651 W. 6th St., Gilroy
WME1	Woodland Mobile Estates 850 W. Middle Avenue Morgan Hill, CA 95037
YMCA	Morgan Hill YMCA, 17666 Crest Ave., Morgan Hill 95037



## ESL (English as a Second Language)

New students who want to take ESL classes at the Gilroy campus will register at the Admissions & Records Office for a placement assessment appointment when completing an application. Call 408-848-4737 or 408-848-4751 to make an appointment or come into Admissions & Records at the Gilroy main campus.

*Students interested in taking ESL courses in Hollister* should contact Judy Rodriguez at (831) 636-3783 or go to the Briggs Building in Hollister to schedule an assessment appointment.

### Who Should Take the ESL Assessment?

- Students who do not know any English.
- Students who know some English but have not received formal classes in the English language or who took ESL classes more than three years ago.
- Students who attended high school in this country for less than a year.
- Students who attended high school in this country for a few years but are unsure about their level of proficiency in English.



### Placement Assessment and Orientation for ESL Applicants

Students who want to enroll in ESL classes must:

- Complete a Gavilan College application at Admissions & Records or at the sites.
- Sign up for a testing appointment at Admissions & Records (Gilroy).
- Return for testing, which includes oral and written exams.

The interview information and the test results will be used to advise and place students into the ESL classes that best match their needs. Students will be ready to register for ESL classes at the end of this three-hour placement assessment appointment.

Orientation for new ESL students will be offered several times during the first two weeks of the semester and will be given in English and Spanish in the classroom setting. New students will be contacted for orientation by their ESL instructors.

## ESL (Inglés como Segunda Lengua)

Los nuevos estudiantes que deseen tomar clases de Inglés como Segunda Lengua (ESL) en Gilroy deben inscribirse en la Oficina de Admisiones y Archivos para hacer una cita y tomar la evaluación apropiada después de llenar una solicitud. Llame 408-848-4737 o 408-848-4751 hacer una cita o venga a la Oficina de Admisiones y Archivos en Gilroy.

*Para aquellos estudiantes que desean estudiar en Hollister*, deben hacer una cita para tomar el examen de nivelación en la oficina en Hollister en el Briggs Building o llamar al 831-636-3783.

### ¿Quién necesita tomar el examen de evaluación de ESL?

- Los estudiantes que no saben nada de inglés.
- Los estudiantes que saben un poco de inglés pero que no han tomado clases formalmente o que tomaron clases hace más de tres años.
- Los estudiantes que asistieron a la secundaria (high school) en este país por menos de un año.
- Los estudiantes que asistieron a la secundaria (high school) en este país por algunos años pero que no están seguros de su nivel de proficiencia en el inglés.

### Asesoramiento, Colocación y Orientación para Estudiantes ESL

Los estudiantes que deseen inscribirse en clases de ESL (Inglés como Segundo Idioma) deben hacer lo siguiente:

- Completar una solicitud de admisión en la Oficina de Admisiones y Archivos.
- Obtener una cita para el examen de nivelación en la Oficina de Admisiones y Archivos (Gilroy).
- Presentarse al examen de nivelación de acuerdo con la cita obtenida para tomar el examen escrito y oral.

Los resultados del examen y la información de la entrevista serán usados para recomendar y colocar a los estudiantes en las clases de Inglés como Segunda Lengua (ESL) que mejor les convengan. Los estudiantes estarán listos para inscribirse en las clases adecuadas al final de esta evaluación de tres horas. Los nuevos estudiantes en el Programa de Inglés como Segunda Lengua (ESL) recibirán una orientación sobre los servicios y regulaciones del Colegio Gavilán en sesiones ofrecidas durante las primeras dos semanas del semestre. Las orientaciones serán dadas en inglés y en español y los maestros se comunicarán con los nuevos estudiantes para asistirlos en seleccionar la sesión más conveniente.

# Información en Español

## La Misión

En un ambiente que fomenta creatividad y curiosidad intelectual, Gavilán "College" sirve a la comunidad ofreciendo experiencias de enseñanza de alta calidad y preparación para educación más avanzada, carreras técnicas y para servicio público, educación para toda la vida, y participación en una sociedad diversa y global.

## Polizas y Procedimientos

Pendiente a la Mesa Directiva.

### Formas Alternativas

El Catálogo y el Horario de Clases del Colegio Gavilán está disponible en formato de medios alternos.

Por favor de contactar El Centro de Recursos para Estudiantes con Incapacidades en (408) 848-4865 o la Oficina del Vicepresidente de Servicios de Estudiante en (408) 848-4738.

### Servicios para los Estudiantes con Incapacidades

Los estudiantes que requieren servicios o arreglos especiales debido a incapacidades auditivas, visuales o alguna otra incapacidad verificado deberán ponerse en contacto con su instructor, consejero, asesor El Centro de Recursos para Estudiantes con Incapacidades.

### No Discriminación

El Distrito está comprometido a proveer igualdad de oportunidades en programas educativos, empleo, y acceso a programas y actividades de la institución.

### Prohibición de Abuso y Ofensas por Discriminación

Referencia: Secciones 212.5; 66252; 66281.5 del Código Educativo

El Distrito está comprometido a proveer un ambiente de enseñanza y de trabajo que respete la dignidad de los individuos y grupos. El Distrito estará libre de ofensa y persecución sexual y todas la formas de intimidación sexual y abuso. También estará libre de otros abusos y ofensas por discriminación incluyendo aquellas ofensas basadas en cualquiera de los siguientes estados: raza, religión, ancestro, origen, impedimento, sexo (género), orientación sexual, o la percepción de que una persona tenga alguna de las características mencionadas.

### Cumplimiento de ADA

Si usted tiene un impedimento verificado y necesita materiales o servicios de estudio en un formato alternativo, contacte El Centro de Recursos para Estudiantes con Incapacidades (DRC) o al Vicepresidente de Servicios Educativos para obtener ayuda. Hay servicios para estudiantes con impedimentos verificados a través de DRC o a través del Vicepresidente de Servicios Educativos.

## Derechos Educativos y Privacidad

Gavilan College está en cumplimiento de los Derechos Educativos Federales y Acto de 1974 (también llamado el Buckley Amendment) y las regulaciones del Título V de California (SB 182). Las siguientes reglas están en efecto:

1. Toda la documentación académica, documentación relacionada con problemas disciplinarios, y cualquiera otra documentación oficial es mantenida para todos los estudiantes que han solicitado admisión a Gavilan College.
2. La documentación oficial es mantenida por y localizada en la Oficina de Admisiones y Registros.
3. La documentación oficial será proveida únicamente cuando la solicitud o permiso sea hecha por escrito por parte del estudiante previo pago de cualquier cargo o costo a la institución, excepto en los casos provistos en ley.
4. La siguiente información puede ser proveida por Gavilan College sin consentimiento escrito por parte del estudiante:
  - a. el nombre del estudiante
  - b. las fechas de matriculación/asistencia a Gavilan College
  - c. la fecha de graduación y título o certificado recibido

La entrega de cualquier otra información requerirá consentimiento escrito del estudiante, excepto en los casos previstos en ley. Los estudiantes pueden notificar su deseo por escrito a la Oficina de Admisiones y Registros durante la primera semana de cada sesión de estudios que no desean que los puntos enumerados en a), b) y c) pueden ser entregados.

5. Los estudiantes tienen derecho a revisar sus propios archivos y la documentación que esté en ellos. Cualquier objeción a éstos archivos debe ser presentada por escrito al Vicepresidente de Instrucción y Servicios al Estudiante. Las objeciones serán resueltas por dicho vicepresidente, y la resolución será inserta en el archivo del estudiante pero no entregada con el resto de la documentación. En caso de desacuerdo sobre éste punto, la Política de Quejas de la institución estará en efecto.

Copias de las regulaciones federales y estatales y del Proceso de Resolución de Problemas Estudiantiles son disponibles a través de la Oficina de Admisiones y Registros y pueden ser revisadas por los estudiantes haciendo una cita con el Vicepresidente de Instrucción y Servicios Estudiantiles o el Director de Admisiones y Registros. El Proceso de Resolución de Problemas Estudiantiles también está disponible en éste catálogo, online, y en el Manual Estudiantil.

## Habilidad en Inglés para Estudios Vocacionales

Habilidad limitada en Inglés no será obstáculo para ser admitido y participante en programas educativos vocacionales.

## Título VI, Título IX, y Norteamericanos con Impedimento/Sección 504/508

Para presentar una queja en cualquiera de las siguientes áreas, por favor comuníquese con el Oficial de Igualdad de Oportunidades, Joseph D. Keeler, Vicepresidente de Servicios Administrativos, HR 101 (408-848-4715) o Shairon Williams, Director de Recursos Humanos, HR103 (408-848-4753).

Las áreas son las siguientes: quejas por violación de derechos civiles (Título VI), quejas por violación de igualdad de género, discriminación sexual, o abuso (Título IX) y quejas por violación contra personas con impedimentos (ADA/Sección 504/508)

## Servicios Estudiantiles y Programas de Apoyo para la Instrucción

### Servicios de Asesoría

Inscribirse y tener éxito en clases a nivel post-secundario requieren dedicación y tiempo. A veces ocurren problemas personales y familiares que distraen a los estudiantes de sus tareas y clases y en estos casos, la única solución parece ser abandonar los estudios. Antes de tomar esta decisión tan difícil, por favor consulte a un consejero. Una buena plática puede ayudar a poner la situación en perspectiva, identificar posibles soluciones, y dar el apoyo necesario para hacer modificaciones necesarias en el horario y las clases. Gavilán College provee consejeros que hablan español y las citas con ellos pueden ser hechas para el día o para la tarde. No hay que pagar por este servicio. Por favor llame al 408-848-4723 para hacer una cita.

### Centro de Desarrollo de Niños

El Centro de Desarrollo de Niños provee cuidado para niños preescolares, en dos programas para familias con ingresos mensuales que satisfacen el criterio de elegibilidad. Estos programas sirven a niños con discapacidades y necesidades especiales y que no hablan inglés. Todos los programas requieren que los padres inviertan ciertas horas como voluntarios.

### El Centro de Recursos para Estudiantes con Incapacidades

El Centro de Recursos para Estudiantes con Incapacidades (DRC) ofrece asesoría individual para evaluar las destrezas de los estudiantes en las áreas de lectura, matemáticas, escritura, razonamiento, lenguaje oral, percepción y memoria. Los estudiantes que requieren servicios o arreglos especiales debido a incapacidades auditivas, visuales o alguna otra incapacidad deberán ponerse en contacto con su instructor, consejero, asesor o la oficina del DRC.

### Servicios de Ayuda Económica Para el Colegio

La ayuda económica para costos del colegio, están disponibles para estudiantes de cualquier tipo de ingreso.

#### OFICINA DE AYUDA ECONÓMICA

Oficina SC 124

Abierto: lunes-jueves: 8 a.m. a 5 p.m., viernes: 8 a.m. a 3 p.m.

Horario de la Tarde: Las horas son extendidas de 5 a 7 pm durante el período de matriculación.

#### CÓDIGO ESCOLAR DEL COLEGIO GAVILÁN ES: 001202

El colegio Gavilán participa en varios programas de ayuda económica, que están diseñados para proporcionar ayuda a los estudiantes de necesidad económica. Esta ayuda es proporcionada por diferentes instituciones incluyendo agencias federales, estatales y privadas.

Si está interesado en solicitar ayuda económica, adquiera una solicitud (FAFSA) en la oficina SC 124 o solicítela usando el Internet en la página [www.fafsa.ed.gov](http://www.fafsa.ed.gov). Si llena la solicitud usando el Internet, imprima y mande la página con su firma (signature page) o use su número secreto (PIN) para firmar la solicitud electrónicamente. Si desea aplicar para obtener su número secreto (PIN) ingrese a [www.PIN.ed.gov](http://www.PIN.ed.gov). Las solicitudes también se pueden obtener por medio de los Consejeros de las Preparatorias (High School), Centro de Carreras de la Preparatoria y Bibliotecas Públicas.

Los requisitos para ayuda económica de parte de FAFSA son:

- Tienen que comprobar que necesitan ayuda económica y que cumplen con las reglas de cada programa.
- Tienen que ser ciudadanos, o ser residentes permanentes de los EE.UU.
- Tienen que tener buen historial en préstamos estudiantiles, y no deber nada a la oficina de ayuda económica.
- Tienen que ser elegibles para recibir los beneficios de una educación superior.
- Hombres entre 18 y 25 años de edad tienen que registrarse en el servicio selectivo (militar).

NOTA: Si ha estado encarcelado por usar o vender drogas ilegales, puede ser no elegible para algunos programas de ayuda económica.

### PÓLIZA DE PROGRESO SATISFACTORIO ACADÉMICO (SAP)

La oficina de ayuda económica requiere medir su progreso académico hacia un certificado, asociado, o un programa de transferencia a la universidad. Si sus metas no son uno de estos programas, no califica para ayuda económica. Su progreso será evaluado por lo mínimo una vez por año.

Si ha sido descalificado, tiene que atender a la sección de (SAP). Vaya a la oficina de ayuda económica para que se registre.

### PROGRAMAS DE AYUDA ECONÓMICA

Ayuda Pagando la Matriculación: El programa (Board of Governor's Fee Waiver/ BOG), ayuda a pagar parte de la matriculación. Solamente para residentes de California. Es para estudiantes de bajo ingreso familiar. La solicitud para el BOG se encuentra en la página 23-24.

#### Becas Gratuitas Federales y Estatales:

- Federal Pell Grant
- Federal SEO Grant
- Cal Grant
- Chafee Grant
- Child Development Grant
- EOPS Grant
- TRIO Grant

Becas Federales de Trabajo y Estudio: Proporciona al estudiante la oportunidad de ganar dinero, mientras aumentan su experiencia de trabajo. Se proporciona la ayuda basándose en la necesidad del estudiante.

Becas Generales: La beca es otorgada basada en el mérito del estudiante y/o necesidad económica. Los requisitos varían y son proporcionados por el donador de la beca. Las solicitudes generales de becas en el Colegio Gavilán se vencen el 2 de Marzo. Becas adicionales tienen diferentes fechas de vencimiento durante el año escolar. Las solicitudes están disponibles en la oficina de ayuda económica. Se recomienda que pregunten sobre las becas varias veces por semestre, porque nuevas becas serán anunciadas en cuanto estén disponibles durante el año escolar.

Servicios Para Miembros de las Fuerzas Armadas (Veteranos): Colegio Gavilán ofrece asistencia especial a estudiantes que son veteranos o hijos de veteranos deshabilitados que asisten al colegio, para lograr una meta. Estudiantes que tengan preguntas sobre si califican, beneficios y el procedimiento de las solicitudes o cualquier otra inquietud sobre veteranos, por favor de contactar la oficina de ayuda económica al 408-848-4734.

**Préstamos Estudiantiles Federales:** Colegio Gavilán participa en el Federal Family Educational Loan Program. Préstamos estudiantiles federales, ofrecen un interés bajo y planes de pago flexibles. Si están interesados en solicitar un préstamo complete la FAFSA y atienda al taller de consejería de préstamo. Solicitudes para el préstamo serán distribuidas en el taller de consejería.

**Becas Privadas:** Becas privadas son fundadas por organizaciones y agencias privadas. Estos fondos se otorgan al estudiante dependiendo de las notas académicas o dependiendo de la necesidad económica del estudiante. Para ser considerado para una beca privada, el estudiante necesita completar una solicitud por cada beca privada a la que se aplique. Visite nuestra oficina para más información.

Solicitudes para la beca privada llamada "Gavilan College Scholarship Application" están disponibles en nuestra oficina.

#### VISÍTENOS EN LA PÁGINA DEL INTERNET A WWW.GAVILAN.EDU/FINAID

Complete la FAFSA en la página del Internet WWW.FAFSA.ED.GOV

Ayuda de planeamiento financiero y consejería de préstamos en la página WWW.EDWISE.ORG

Averigüe su estado de préstamo en la página WWW.EDFUND.ORG

Regístrate para Servicios Selectivos en la página WWW.SSS.GOV

Aplique para su número de identificación personal (PIN) en la página WWW.PIN.ED.GOV

Nunca es tarde para obtener tu GED. Revisa este nuevo curso GRATIS en la página 42.

¿Necesitas refrescar un poco tus habilidades de inglés para poder comunicarte con tus compañeros de trabajo? Revisa esta clase GRATIS de Inglés Vocacional en la página 42.

Para información sobre clases de ESL, refiérase a la página 90.

Revise la clase ESL 522 Lectura y Vocabulario ofrecida por primera vez en plan nocturno en el campus principal. Vea la página 90.

Revise la nueva clase para principiantes ofrecida en Morgan Hill en plan nocturno. Vea la página 90.

Para información sobre clases de destrezas básicas, refiérase a la página 88-89 (ENGL 420, 439, 440) y página 102 (MATH 400, 402).

## El Centro de Desarrollo Infantil del Colegio Gavilán

provee cuidado de niños hasta la edad de cinco años mientras que usted asiste a sus clases.

**(408) 848-4815**  
Acreditado por NAEYC

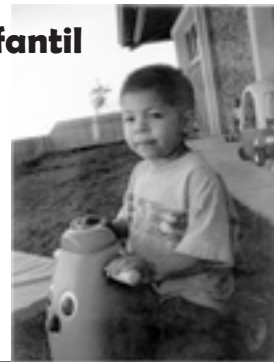

## CalWORKs

Programa de California de Oportunidad de Trabajo y Responsabilidad Hacia sus Niños

¡Vuelvase independiente a través de educación, empleo y servicios de sostenimiento!



El programa CalWORKs del Colegio de Gavilán, localizado en el cuarto LI101A, provee soporte a estudiantes que reciben asistencia pública. Para más información, llame a 408-848-4813 o 408-848-4740.

## ¿Necesita ayuda para comprar libros?

Si usted ya compro su tarjeta de Cuerpo Asociado de Estudiantes (ASB) usted podrá aplicar para prestamos (maximo \$200) para comprar libros, en la Oficina de Ayuda Financiera, cuarto SC124.

Usted puede comprar la tarjeta de ASB en la Oficina de Admisiones y Archivos, cuarto SC 111.



# Monday/Wednesday on the main campus

**8:10 a.m.**

4085	ART 2A	DESIGN	810A	1115A	AR103
4456	HIST 2	U.S. HISTORY	810A	925A	SS205
4004	ACCT 111	INTRO INCOME TAX	810A	935A	BU120
4186	CMUN 1A	INTRO PUBLIC SPEAK	810A	935A	TH127
4323	ENGL 1C	CRITIC REASON/WRITE	810A	935A	HU102
4727	PE 25	SOCCER	810A	935A	GY131G
4784	POLS 1	UNITED STATES INST.	810A	935A	SS210
4797	PSYC 1A	INTRO TO PSYCHOLOGY	810A	935A	SS214

**8:40 a.m.**

4093	ART 10A	CULT HIST CERAMICS	840A	1110A	AR101
------	---------	--------------------	------	-------	-------

**8:45 a.m.**

4148	BIO 15	SURVEY ANAT/PHYSIOL Lab: M	845A 1120A	1050A 225P	LS101 LS103
------	--------	-------------------------------	---------------	---------------	----------------

**9:00 a.m.**

4684	MUS 3B	HARMONY-THEORY	900A	1105A	TH130
4685	MUS 3C	HARMONY-THEORY	900A	1105A	TH130
4686	MUS 3D	HARMONY-THEORY	900A	1105A	TH130
4902	ACCT 20	FINANCIAL ACCT	900A	1105P	BU118

**9:45 a.m.**

4066	AJ 21	NARC/DRUG ABUSE	945A	1110A	BU120
4059	AJ6	INTRO CONFLICT RES	945A	1110A	SS205
4123	ART 117	MOTION GRAPHICS	945A	1110A	LI128
4194	CMUN 4	INTERCULTURAL COMM	945A	1110A	TH127
4195	CMUN 6	INTRO CONFLICT RES	945A	1110A	SS205
4304	ENGL 1A	COMPOSITION	945A	1110A	HU103
4317	ENGL 1B	COMPOSITION & LIT	945A	1110A	HU102
4369	ENGL 260	PREP/COLLEGE READNG	945A	1110A	SS203
4377	ENGL 420	READING IMPROVE Lab: M	945A 1255P	1110A 155P	CJ500 LI120
4462	HIST 12	CULT HIST/MEX-AMER	945A	1110A	SS210
4460	HIST 6	WOMEN/RECENT US HIS	945A	1110A	SS110
4682	MUS 1B	MUSIC HISTORY/LIT	945A	1110A	AL101
4778	PHIL 4	CRITICAL THINK/WRIT	945A	1110A	SS111
4789	POLS 3	COMPARATIVE GOVTS	945A	1110A	LI171
4791	POLS 6	INTRO CONFLICT RES	945A	1110A	SS205
4803	PSYC 1B	INTRO TO PSYCHOLOGY	945A	1110A	SS214
4809	PSYC 6	INTRO CONFLICT RES	945A	1110A	SS205
4842	THEA 16	INTRO TO TELEVISION	945A	1110A	LI144

**11:20 a.m.**

4419	GUID 1	SELF ASSESSMENT	1120A	1225P	CH102
4605	JOUR 18A	WRKNG ON THE N/PAPE	1120A	1225P	HU106
4609	JOUR 18B	WORK ON THE NEWSPAP	1120A	1225P	HU106
4613	JOUR 18C	WORK ON THE NEWSPAP	1120A	1225P	HU106
4617	JOUR 18D	WORK ON THE NEWSPAP	1120A	1225P	HU106
4079	ANTH 1	INTRO PHYSICAL ANTH	1120A	1245P	SS210
4095	ART 11	CREATIVITY/IMAGIN	1120A	1245P	AR103
4089	ART 6	ART APPRECIATION	1120A	1245P	AL101
4189	CMUN 1A	INTRO PUBLIC SPEAK	1120A	1245P	LI171/LS104
4201	CMUN 10	SMALL GROUP CMUN	1120A	1245P	TH127
4300	ECON 2	PRIN MICROECONOMICS	1120A	1245P	BU120
4307	ENGL 1A	COMPOSITION	1120A	1245P	HU103
4390	ENGL 440	BASIC WRITING Lab: W	1120A 1255P	1245P 155P	CJ500 LI120
4331	ENGL 9A	INTRO CREATIVE WRIT	1120A	1245P	SS111
4332	ENGL 9B	ADV CREATIVE WRITNG	1120A	1245P	SS111
4333	ENGL 9C	POETRY WRITING	1120A	1245P	SS111
4464	HUM 10	APPROACH CONT FILM	1120A	1245P	SS214
4719	PE 17	GOLF	1120A	1245P	GY200C
4720	PE 17	GOLF	1120A	1245P	GY200C
4744	PE 44	AEROBICS	1120A	1245P	GY131G

**11:20 a.m. cont.**

4818	SOC 3	SOC OF MINORITIES	1120A	1245P	SS205
4833	SSCI 270B	INTRO SOCIAL SCIENCE	1120A	1245P	SS110
4838	THEA 11	DANCE & MVMT/THEA	1120A	1245P	TH125
4845	THEA 19	TV / FILM ACTING	1120A	1245P	LI144
4060	AJ 10	INTRO ADMIN JUST	1120A	1250P	BU118
4688	MUS 4A	BEGINNING PIANO	1120A	125P	TH130
4606	JOUR 18A	WRKNG ON THE N/PAPE	1120A	150P	HU106
4607	JOUR 18A	WRKNG ON THE N/PAPE	1120A	150P	HU106
4608	JOUR 18A	WRKNG ON THE N/PAPE	1120A	150P	HU106
4610	JOUR 18B	WORK ON THE NEWSPAP	1120A	150P	HU106
4611	JOUR 18B	WORK ON THE NEWSPAP	1120A	150P	HU106
4612	JOUR 18B	WORK ON THE NEWSPAP	1120A	150P	HU106
4614	JOUR 18C	WORK ON THE NEWSPAP	1120A	150P	HU106
4615	JOUR 18C	WORK ON THE NEWSPAP	1120A	150P	HU106
4616	JOUR 18C	WORK ON THE NEWSPAP	1120A	150P	HU106
4618	JOUR 18D	WORK ON THE NEWSPAP	1120A	150P	HU106
4619	JOUR 18D	WORK ON THE NEWSPAP	1120A	150P	HU106
4620	JOUR 18D	WORK ON THE NEWSPAP	1120A	150P	HU106
4094	ART 10B	CERAMICS	1120A	225P	AR101
4086	ART 3A	DRAW/COMPOSITION	1120A	225P	AR102
4148	BIO 15	SURVEY ANAT/PHYSIOL Lab: M	1120A 1120A	225P 225P	LS103 LS103

**12:45 p.m.**

4879	CMUN 129	PRESENTATN GRAPHICS	1245P	200P	LI120
4878	CSIS 129	PRESENTATN GRAPHICS	1245P	200P	LI120

**12:55 p.m.**

4377	ENGL 420	READING IMPROVE Lab: M	1255P 1255P	155P 155P	LI120 LI120
4390	ENGL 440	BASIC WRITING Lab: W	1255P 1255P	155P 155P	LI120 LI120
4299	ECON 1	PRIN MACROECONOMICS	1255P	210P	BU120
4082	ANTH 3	INTRO CULTURAL ANTH	1255P	220P	SS205
4196	CMUN 8	INTERPERSONAL COMM	1255P	220P	TH127
4309	ENGL 1A	COMPOSITION	1255P	220P	CJ500
4375	ENGL 260	PREP/COLLEGE READNG	1255P	220P	SS203
4380	ENGL 420	READING IMPROVE Lab: M	1255P 230P	220P 330P	SS111 SS111
4381	ENGL 420	READING IMPROVE Lab: W	1255P 230P	220P 330P	SS111 SS111
4454	HIST 1	US HISTORY	1255P	220P	SS214
4459	HIST 2	U.S. HISTORY	1255P	220P	SS210
4689	MUS 4B	BEGINNING PIANO	1255P	220P	TH130
4690	MUS 5A	INTERMED PIANO	1255P	220P	TH130
4691	MUS 5B	INTERMED PIANO	1255P	220P	TH130
4692	MUS 5C	ADVANCED PIANO	1255P	220P	TH130
4693	MUS 5D	ADVANCED PIANO	1255P	220P	TH130
4717	PE 16	SWIMMING	1255P	220P	GY100P
4718	PE 16	SWIMMING	1255P	220P	GY100P
4723	PE 21	VOLLEYBALL	1255P	220P	GY131G
4751	PE 70	PILATES	1255P	220P	APE101
4780	PHIL 6A	COMPARATIVE RELIGIONS	1255P	220P	HU103
4821	SOC 21	MARRIAGE & FAMILY	1255P	220P	OE001
4841	THEA 14	STAGE PRODUCTION	1255P	220P	TH125
4885	THEA 14	STAGE PRODUCTION	1255P	220P	TH125
4886	THEA 14	STAGE PRODUCTION	1255P	220P	TH125
4002	ACCT 21	MANAGERIAL ACCT	1255P	300P	BU118
4699	MUS 12	VOCAL ENSEMBLE	1255P	300P	AL101
4700	MUS 14A	INSTRUMENTAL ENSEMBLE	1255P	300P	AL101
4701	MUS 14B	INSTRUMENTAL ENSEMBLE	1255P	300P	AL101
4702	MUS 14C	INSTRUMENTAL ENSEMBLE	1255P	300P	AL101
4703	MUS 14D	INSTRUMENTAL ENSEMBLE	1255P	300P	AL101
4119	ART 8A	DIGITAL PHOTOGRAPHY	1255P	325P	LI128
4627	JPN 1A	ELEMENTARY JAPANESE	1255P	325P	HU104
4418	GEOL 1	INTRO GEOLOGY L/L	1255P	405P	CH102

## Monday only - main campus

## 2:30 p.m.

4380	ENGL 420	READING IMPROVE Lab: M	230P	330P	SS111
4381	ENGL 420	READING IMPROVE Lab: W	230P	330P	SS111
4063	AJ 12	CRIMINAL PROCEDURE	230P	350P	BU120
4139	BIO 10	PRIN BIOLOGY L/L Lab: M	230P	350P	SS214
4140	BIO 10	PRIN BIOLOGY L/L Lab: M	230P	350P	SS214
4141	BIO 10	PRIN BIOLOGY L/L Lab: W	230P	350P	SS214
4142	BIO 10	PRIN BIOLOGY L/L Lab: W	230P	350P	SS214
4311	ENGL 1A	COMPOSITION	230P	355P	HU103
4326	ENGL 1C	CRITIC REASON/WRITE	230P	355P	CJ500
4801	PSYC 1A	INTRO TO PSYCHOLOGY	230P	405P	SS210
4643	MATH 5	INTRO STATISTICS	230P	435P	PH103

## 4:00 p.m.

4366	ENGL 250	PRACTICAL WRITING Lab: M	400P	525P	SS203
4367	ENGL 250	PRACTICAL WRITING Lab: W	400P	525P	SS203

## Evening

6103	ENGL 260	PREP/COLLEGE READNG	530P	655P	SS203
6089	ECON 11	BUS/ECON STATISTICS	600P	805P	BU118
6116	GBUS 11	BUS/ECON STATISTICS	600P	805P	BU118
6132	MATH 1A	CALC/ANAL GEOM I	630P	835P	CH109
6142	MATH 400	ELEM ARITHMETIC	630P	835P	SS206
6135	MATH 8A	FIRST HALF PRECALCULUS	630P	835P	PH102
6027	BIO 10	PRIN BIOLOGY L/L	630P	855P	LS102
6137	MATH 205	ELEM ALGEBRA	630P	900P	PH103
6102	ENGL 250	PRACTICAL WRITING	700P	905P	SS203

## 11:20 a.m.

4121	ART 108	DIGITAL MEDIA LAB	1110A	1245P	LI128
------	---------	-------------------	-------	-------	-------

## 2:30 p.m.

4197	CMUN 8	INTERPERSONAL COMM	230P	540P	TH127
------	--------	--------------------	------	------	-------

## Evening

6150	MUS 9A	GIUITAR	530P	840P	AL101
6158	MUS 23	INDEPENDENT STUDY	600P	850P	AL101
6032	BOT 181	MEDICAL BILLING	600P	910P	BS110
6037	CD 4	OBSERVING CHILDREN	600P	910P	CH102
6051	CMUN 11	BUSINESS CMUN	600P	910P	TH127
6151	MUS 9B	GIUITAR	600P	910P	AL101
6171	PSYC 1A	INTRO TO PSYCHOLOGY	600P	910P	SS214
6092	ENGL 1A	COMPOSITION	630P	940P	HU103
6118	GBUS 80	BUSINESS LAW	630P	940P	BU120
6144	MUS 4A	BEGINNING PIANO	630P	940P	TH130
6145	MUS 4B	BEGINNING PIANO	630P	940P	TH130
6146	MUS 5A	INTERMED PIANO	630P	940P	TH130
6147	MUS 5B	INTERMED PIANO	630P	940P	TH130
6148	MUS 5C	ADVANCED PIANO	630P	940P	TH130
6149	MUS 5D	ADVANCED PIANO	630P	940P	TH130
6163	PE 39	FENCING	630P	940P	GY131G
6169	POLS 1	UNITED STATES INST.	630P	940P	SS210
6174	RE 160	REAL ESTATE PRINC	630P	940P	SS205

## Wednesday only - main campus

## 9:45 a.m.

4039	AH 30	1ST AID/CPR	945A	1150A	LS104
4005	ACCT 120	COMPUTERIZED ACCTNG	945A	1240P	BU111

## 11:20 a.m.

4420	GUID 1	SELF ASSESSMENT	1120A	125P	SC154N
4421	GUID 1	SELF ASSESSMENT	1120A	125P	SC154N

## 3:30 p.m.

4813	PSYC 52	PEER COUNSELING	230P	435P	OE002
------	---------	-----------------	------	------	-------

## Evening

6098	ENGL 9A	INTRO CREATIVE WRIT	530P	840P	HU102
6099	ENGL 9B	ADV CREATIVE WRITNG	530P	840P	HU102
6100	ENGL 9C	POETRY WRITING	530P	840P	HU102
6046	CD 30B	TEACH PRAC&TECH. II	600P	910P	CH102
6180	SPAN 8B	CONVER SPANISH	600P	910P	HU105
6026	ASTR 1	INTRO GEN ASTRONOMY	630P	940P	LS101
6096	ENGL 1C	CRITIC REASON/WRITE	630P	940P	HU103
6097	ENGL 2C	INTRO FILM/FICTION	630P	940P	SS214
6161	MUS 98	SPECIAL TOPICS	730P	945P	AL101

Many additional classes with different starting and ending times are also available on these days.

Please see class descriptions within the discipline.

# Tuesday/Thursday on the main campus

**8:10 a.m.**

4160	CD 6	GAMES/RHYTHMS CHLD	810A	925A	APE120
4795	POLS 27	CONTEMP LEADERSHIP	810A	930A	LS101
4812	PSYC 27	CONTEMP LEADERSHIP	810A	930A	LS101
4064	AJ 14	CRIMINAL LAW	810A	935A	BU118
4084	ART 1B	ART HISTORY	810A	935A	AL101
4302	ENGL 1A	COMPOSITION	810A	935A	CJ500
4368	ENGL 260	PREP/COLLEGE READNG	810A	935A	HU102
4385	ENGL 440	BASIC WRITING Lab: Tu	810A	935A	SS203
			1010A	1110A	LI171
4386	ENGL 440	BASIC WRITING Lab: Th	810A	935A	SS203
			1010A	1110A	LI171
4645	MATH 6	CALCULUS BUS/SOC SC	810A	935A	PH102
4716	PE 6	GAMES/RHYTHMS CHLD	810A	935A	APE120
4777	PHIL 2	LOGIC	810A	935A	AR103
4785	POLS 1	UNITED STATES INST.	810A	935A	SS210
4798	PSYC 1A	INTRO TO PSYCHOLOGY	810A	935A	SS214

**9:00 a.m.**

4088	ART 3B	DRAW/COMPOSITION	900A	1105A	AR102
4683	MUS 3A	HARMONY-THEORY	900A	1105A	TH130
4687	MUS 4A	BEGINNING PIANO	900A	1105A	TH130

**9:45 a.m.**

4065	AJ 16	INTRO TO EVIDENCE	945A	1110A	BU118
4081	ANTH 3	INTRO CULTURAL ANTH	945A	1110A	SS205
4118	ART 77	INTRO DIGITAL MEDIA	945A	1110A	LI128
4161	CD 10	SPECIAL NEEDS CHILDREN	945A	1110A	CD127
4200	CMUN 10	SMALL GROUP CMUN	945A	1110A	TH127
4193	CMUN 2	ORAL READING	945A	1110A	LI144
4305	ENGL 1A	COMPOSITION	945A	1110A	HU103
4318	ENGL 1B	COMPOSITION & LIT	945A	1110A	CJ500
4352	ENGL 250	PRACTICAL WRITING Lab: Tu	945A	1110A	SS203
			835A	935A	LI120
4353	ENGL 250	PRACTICAL WRITING Lab: Th	945A	1110A	SS203
			835A	935A	LI120
4370	ENGL 260	PREP/COLLEGE READNG	945A	1110A	HU102
4371	ENGL 260	PREP/COLLEGE READNG	945A	1110A	HU102
4450	HE 1	HEALTH EDUCATION	945A	1110A	LS104
4458	HIST 2	U.S. HISTORY	945A	1110A	SS210
4779	PHIL 4	CRITICAL THINK/WRIT	945A	1110A	AR103
4814	SOC 1A	INTRO TO SOCIOLOGY	945A	1110A	SS214
4820	SOC 21	MARRIAGE & FAMILY	945A	1110A	SS110
4836	THEA 4	ORAL READING	945A	1110A	LI144
4837	THEA 7	INTRO TO THEATRE	945A	1110A	TH125
4782	PHYS 1	INTRO TO PHYSICS	945A	1250P	PH102

**11:20 a.m.**

4117	ART 75	PHOTOSHOP I	1120A	1240P	LI128
4083	ANTH 5	MAGIC/WITCH/RELIG	1120A	1245P	SS210
4157	CD 2	EARLY CHILD DEVELOP	1120A	1245P	LS104
4190	CMUN 1A	INTRO PUBLIC SPEAK	1120A	1245P	TH127
4308	ENGL 1A	COMPOSITION	1120A	1245P	CJ500
4319	ENGL 1B	COMPOSITION & LIT	1120A	1245P	CH102
4358	ENGL 250	PRACTICAL WRITING Lab: Tu	1120A	1245P	HU102
			835A	935A	SS111
4359	ENGL 250	PRACTICAL WRITING Lab: Th	1120A	1245P	HU102
			835A	935A	SS111
4373	ENGL 260	PREP/COLLEGE READNG	1120A	1245P	HU103
4374	ENGL 260	PREP/COLLEGE READNG	1120A	1245P	HU103
4329	ENGL 2J	MYTHOLOGY	1120A	1245P	SS111
4393	ENGL 440	BASIC WRITING Lab: Tu	1120A	1245P	SS203
			1255P	155P	LI171
4394	ENGL 440	BASIC WRITING Lab: Th	1120A	1245P	SS203
			1255P	155P	LI171
4453	HIST 1	US HISTORY	1120A	1245P	SS214
4661	MATH 205B	SECOND HALF ALGEBRA	1120A	1245P	SS206
4704	MUS 21	ELECTRONIC MUSIC	1120A	1245P	LI128
4694	MUS 8A	BEGINNING VOICE	1120A	1245P	TH130
4695	MUS 8B	BEGINNING VOICE	1120A	1245P	TH130
4696	MUS 8C	INTERMED VOICE	1120A	1245P	TH130

**11:20 a.m. cont.**

4697	MUS 8D	INTERMED VOICE	1120A	1245P	TH130
4752	PE 73	FITNESS THROUGH DANCE	1120A	1245P	APE101
4804	PSYC 2	EARLY CHILD DEVELOP	1120A	1245P	LS104
4817	SOC 1B	INTRO TO SOC/PROBLM	1120A	1245P	SS205
4061	AJ 10	INTRO ADMIN JUST	1120A	1250P	BU118
4298	ECON 1	PRIN MACROECONOMICS	1120A	1250P	BU120
4839	THEA 12A	ACTING: HIST/PRACT	1120A	125P	TH125
4840	THEA 12B	ACTING TECHNIQUES	1120A	125P	TH125
4087	ART 3A	DRAW/COMPOSITION	1120A	225P	AR102
4092	ART 8A	BEG B/W PHOTOGRAPHY	1120A	225P	AR103

**12:55 p.m.**

4416	GBUS 1	FUND OF BUSINESS	1255P	210P	BU120
4191	CMUN 1A	INTRO PUBLIC SPEAK	1255P	220P	TH127
4296	ECOL 1	CONS NATURAL RESOUR Lab: Tu	1255P	220P	LS101
			230P	535P	LS102
4297	ECOL 1	CONS NATURAL RESOUR Lab: Th	1255P	220P	LS101
			230P	535P	LS102
4310	ENGL 1A	COMPOSITION	1255P	220P	HU102
4325	ENGL 1C	CRITIC REASON/WRITE	1255P	220P	CJ500
4364	ENGL 250	PRACTICAL WRITING Lab: Tu	1255P	220P	SS203
			230P	330P	LI171
4365	ENGL 250	PRACTICAL WRITING Lab: Th	1255P	220P	SS203
			230P	330P	LI171
4382	ENGL 420	READING IMPROVE Lab: Tu	1255P	220P	SS111
			0230P	0330P	SS111
4383	ENGL 420	READING IMPROVE Lab: Th	1255P	220P	SS111
			0230P	0330P	SS111
4424	GUID 1	SELF ASSESSMENT	12:55P	2:00P	OE001
4455	HIST 1	US HISTORY	1255P	220P	SS210
4461	HIST 7B	HIST WESTERN CIVIL	1255P	220P	SS205
4465	HUM 10	APPROACH CONT FILM	1255P	220P	SS214
4604	JOUR 10	MASS MEDIA & SOCIET	1255P	220P	AL101
4646	MATH 7	FINITE MATHEMATICS	1255P	220P	PH102
4747	PE 62	YOGA	1255P	220P	APE101
4776	PHIL 1	INTRO PHILOSOPHY	1255P	220P	CH102
4806	PSYC 5	SELF ASSESSMENT	12:55P	2:00P	OE001
4819	SOC 10	MASS MEDIA & SOCIET	1255P	220P	AL101
4001	ACCT 20	FINANCIAL ACCT	1255P	300P	BU118
4843	THEA 17A	TV/VIDEO WORKSHOP	1255P	325P	LI144
4844	THEA 17B	TV/VIDEO WORKSHOP	1255P	325P	LI144
4184	CHEM 12B	ORGANIC CHEMISTRY	1255P	535P	LS102/CH101

**2:30 p.m.**

4098	ART 21	ANCIENT AMERICAS	230P	355P	SS205
4192	CMUN 1A	INTRO PUBLIC SPEAK	230P	355P	TH127
4320	ENGL 1B	COMPOSITION & LIT	230P	355P	HU102
4463	HIST 21	ANCIENT AMERICAS	230P	355P	SS205
4816	SOC 1A	INTRO TO SOCIOLOGY	230P	405P	SS210
4728	PE 27	BASKETBALL	230P	430P	GY131G
4640	MATH 1C	MULTIVARI CALCULUS	230P	435P	PH102

**4:00 p.m.**

4198	CMUN 8	INTERPERSONAL COMM	400P	525P	TH127
4312	ENGL 1A	COMPOSITION	400P	525P	HU102
4327	ENGL 1C	CRITIC REASON/WRITE	400P	525P	HU103

**Evening**

6164	PE 61	SWIM FOR FITNESS	515P	640P	GY100P
6104	ENGL 420	READING IMPROVE	530P	735P	SS203
6523	JPN 1B	ELEMENTARY JAPANESE	530P	800P	SS110
6017	ART 10A	CULT HIST CERAMICS	600P	830P	AR101
6024	ART 98	SPECIAL TOPICS	600P	850P	AR101
6018	ART 10B	CERAMICS	600P	910P	AR101
6048	CHEM 30A	ELEM CHEMISTRY L/L	600P	905P	CH109
6133	MATH 5	INTRO TO STATISTICS	630P	840P	LS101/PH101
6139	MATH 205B	SECOND HALF ALGEBRA	630P	835P	SS206
6143	MATH 402	PRE-ALGEBRA	630P	835P	PH102
6141	MATH 233	INTERMED ALGEBRA	630P	900P	PH103
6105	ENGL 440	BASIC WRITING	740P	945P	SS203

## Tuesday only - main campus

### 11:10 a.m.

4853	THEA 98	SPECIAL TOPICS	1110A	1200P	OE003
4854	THEA 98	SPECIAL TOPICS	1110A	1200P	OE003

### 12:55 p.m.

4034	AH 11	NUTRITION	1255P	400P	LS104
------	-------	-----------	-------	------	-------

### 2:30 p.m.

4129	ASTR 1	INTRO GEN ASTRONOMY	230P	540P	SS214
------	--------	---------------------	------	------	-------

### 4:10 p.m.

4035	AH 11	NUTRITION	410P	710P	LS104
------	-------	-----------	------	------	-------

### Evening

6003	ACCT 21	MANAGERIAL ACCT	545P	950P	BU120
6087	ECON 1	PRIN MACROECONOMICS	600P	910P	SS205
6121	HIST 4A	HIST WORLD SOCIETIES	600P	910P	SS210
6136	MATH 14	MATH/LIBERAL ARTS	600P	910P	LS102
6030	BIOT 104	BIOTECHNOLOGY SEMINAR	630P	730P	LS103
6181	SPAN 23	INDEPENDENT STUDY	630P	920P	HU103
6177	SOC 21	MARRIAGE & FAMILY	630P	940P	SS214

## Thursday only - main campus

### 9:35 a.m.

4185	CHEM 30B	ELEM ORG/BIOCHEM	945A	1250P	CH101
------	----------	------------------	------	-------	-------

### 12:55 p.m.

4031	AH 3	PERSON/LIFE CYCLE	1255P	400P	LS104
------	------	-------------------	-------	------	-------

### 2:30 p.m.

4334	ENGL 12A	TUTORING WRITERS	230P	400P	LI120
4336	ENGL 12B	TUTORING WRITERS	230P	400P	LI120
4338	ENGL 12C	TUTORING WRITERS	230P	400P	LI120
4335	ENGL 12A	TUTORING WRITERS	230P	435P	LI120
4337	ENGL 12B	TUTORING WRITERS	230P	435P	LI120
4339	ENGL 12C	TUTORING WRITERS	230P	435P	LI120

### 4:10 p.m.

4032	AH 3	PERSON/LIFE CYCLE	410P	710P	LS104
------	------	-------------------	------	------	-------

### Evening

6012	AJ 176	CRIMINAL STREET GANGS	600P	910P	SS210
6040	CD 12	COMPUTER ED TEACHER	600P	910P	LI171
6095	ENGL 1B	COMPOSITION & LIT	630P	940P	HU102
6175	RE 167	REAL ESTATE ECON	630P	940P	BU120
6519	HUM 4	INTRO AMER CINEMA	630P	940P	SS214

## Friday only classes

SECT	COURSE		TIME	ROOM
4867	ACCT 103	GEN OFFICE ACCT	900A-1210P	BU120
6502	ACCT 120	COMPUTERIZED ACCTNG	530P-840P	HOL3
6020	ART 25A	ART METHODS	400P-815P	HOL1
6021	ART 25B	CONCEPT ART METHODS	400P-815P	HOL1
4096	ART 12A	SCULPTURE	900A-105P	AR101
4122	ART 114	DIGITAL MEDIA PROD	1110A-115P	LI128
6521	CD 25A	ART METHODS	400P-815P	HOL1
6044	CD 25B	CONCEPT ART METHODS	400P-815P	HOL 1
4889	CSIS 2	COMPUTERS IN BUSNS	945A-1110A	BU111
4223	CSIS 2L	COMPUTRS/BUSNS LAB	945A-1110A	BU111
4229	CSIS 10	BASIC PROGRAMMING	945A-1145A	BU118
4241	CSIS 114	DIGITAL MEDIA PROD	1110A-115P	LI128
6515	CSIS 120	COMPUTER ACCOUNTING	530P-840P	HOL3
4243	CSIS 121	SPREADSHEET-MS EXCL	945A-1145P	BU118
4292	DM 114	DIGITAL MEDIA PROD	1110A-115P	LI128
4303	ENGL 1A	COMPOSITION	810A-1120A	HU103
4316	ENGL 1B	COMPOSITION & LIT	810A-1120A	HU102
4372	ENGL 260	PREP/COLLEGE READNG	1030A-140P	SS203
4422	GUID 1	SELF ASSESSMENT	1140A-145P	SS205
4423	GUID 1	SELF ASSESSMENT	1120A-125P	SS205
4649	MATH 201A	MATH FOR SCI & ENGR	920A-1020A	SS206
4650	MATH 201B	MATH SCI & ENGR	920A-1020A	PH103
4721	PE 19	BADMINTON	1040A-140P	GY131G

## Get College Credit for Working or Volunteering!



### Cooperative Work Experience

is available to day, evening, full-time and part-time students.

If your job or volunteer work is directly related to your education or occupational goals sign up for:

### CWE 190: Occupation Work Experience Education

If your job or volunteer work is not directly related to your educational goals sign up for:

### CWE 192: General Work Experience Education

Call 408-846-4993 for more information.

Many additional classes with different starting and ending times are also available on these days. Please see class descriptions within the discipline.



# NONCREDIT PROGRAM

This program is open to all students and currently offers classes in basic literacy, short-term vocational and other classes of interest to the community as well as Staff Wellness and Older Adult courses.

All classes are free of charge. There are no tests, no quizzes and no letter grades. Registration will take place in the Admissions & Records Office or on the first day of class. Students should contact the Noncredit Office directly with any questions or for further information at (408) 848-4859.

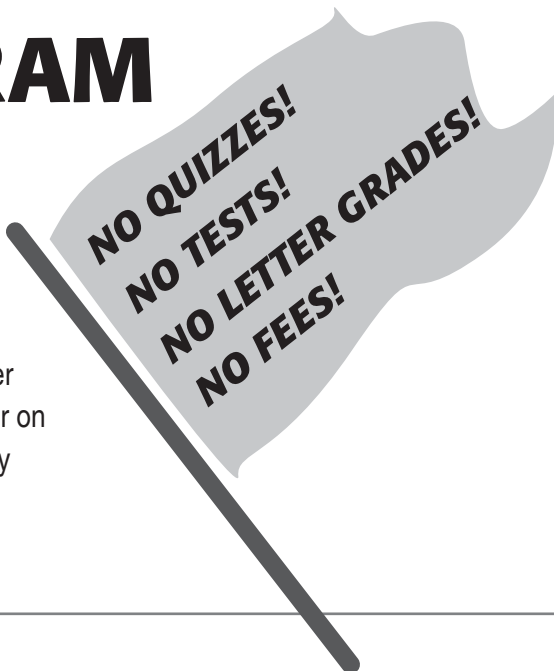

**NO QUIZZES!  
NO TESTS!  
NO LETTER GRADES!  
NO FEES!**

## Adults 55+

This program offers special interest classes to adults 55 and older. Our classes take place at various older adult facilities as well as Gavilan campuses to ensure positive enrollment and convenience for the students.

- Arts and Crafts
- Body Dynamics and the Aging Process
- Coping with Loss
- Creative Writing Workshop
- Film Classics
- Finding Book Treasures
- Internet Literacy for Older Adults
- Music Encounters
- The Joy of Listening to Music
- Journal Writing
- Music, Movement & Wellness
- Tai Chi for Arthritis and Other Illnesses
- The Theater Experience
- Writing Your Autobiography

More Older Adult classes coming soon!...

- Armchair Travels
- As Others See Americans
- Computer Literacy
- Topics for Seniors, Staying Well Informed

## Staff Wellness Program

This program is geared toward meeting the needs of our Gavilan College family. All classes are free of charge and are open to all staff members as well as the community.

- Tai Chi for Health
- Mindful Stress Reduction

Staff Wellness Coming soon!...

- Weight Control
- Workplace Fitness

## Parenting Program

- Parent Advocacy

## Basic Skills Program

- Citizenship
- GED Preparation
- Introduction to Online Gavilan

# SPRING NONCREDIT CLASSES

## ALLIED HEALTH

### AH 740 Tai Chi for Arthritis and Other Related Illnesses

**Transferable:** No

This course is designed for the maintenance of the physical and mental well-being of an older adult with arthritis and other related illnesses. Instruction will focus on the postures and movements of Tai Chi, a Chinese exercise regimen that has a slow paced movement that improves balance, coordination, breathing and builds strength and stamina. Activities are included that promote self-care and health awareness.

4054	LAB	PHM1	SWEENEY L	2.00	.0	TuTh	1000A-1100A
02/01/07 - 04/03/07 See Footnote: Above class meets Off Campus							
4055	LAB	PHM1	SWEENEY L	2.00	.0	TuTh	1000A-1100A
04/05/07 - 06/12/07 See Footnote: Above class meets Off Campus							
4056	LAB	HOLCC	ROTH R	1.00	.0	Th	1100A-1200P
02/01/07 - 06/07/07 See Footnote: Above class meets Off Campus							
4057	LAB	GHR1	ROTH R	2.00	.0	TuTh	0930A-1030A
02/06/07 - 04/05/07 See Footnote: Above class meets Off Campus							
4058	LAB	GHR1	ROTH R	2.00	.0	TuTh	0930A-1030A
04/17/07 - 06/14/07 See Footnote: Above class meets Off Campus							
4870	LAB	VPRH	ROTH R	1.00	.0	Th	0100P-0200P
02/01/07 - 06/07/07 See Footnote: Above class meets Off Campus							
4871	LAB	WM1	GERUSA R	2.00	.0	TuTh	1000A-1100A
02/01/07 - 04/03/07 See Footnote: Above class meets Off Campus							
4872	LAB	WM1	GERUSA R	1.00	.0	TuTh	1000A-1100A
04/05/07 - 06/12/07 See Footnote: Above class meets Off Campus							
6009	LAB	GHS	SMITH S	1.00	.0	S	1045A-1145A
02/03/07 - 06/02/07 See Footnote: Above class meets Off Campus							

### AH 742 Coping with Loss

**Transferable:** No

In this course, the older adult will learn that grief and loss are an integral part of the human experience and they are not alone and that grief is universal. Specific topics will include: the process of normal grieving, tools for effective coping, signs of depression, resiliency skills, and resources available in the community and redefining one's life after a loss.

4877	LEC	COGMR	DASS R	2.00	.0	Tu	0100P-0300P
02/06/07 - 03/27/07 See Footnote: Above class meets Off Campus							

## ART

### ART 760 Arts and Crafts I for Older Adults

**Transferable:** No

A general survey of arts and crafts with an emphasis on exercises and experiments with methods and materials, including: painting, drawing, color theory, composition and rendering, batik or tie-dye, quilting or needlepoint, crocheting or knitting and block printing.

4857	LAB	HVME1	GUPTA R	3.00	.0	F	0930A-1230P
02/02/07 - 06/15/07 See Footnote: Above class meets Off Campus							
4858	LAB	LOADCS	LAAGE D	3.00	.0	MW	1045A-1215P
01/29/07 - 06/13/07 See Footnote: Above class meets Off Campus							
4859	LAB	WM1	BARRETT S	3.00	.0	M	0100P-0400P
01/29/07 - 06/18/07 See Footnote: Above class meets Off Campus							

## ENGLISH

### ENGL 752 Journal Writing for Older Adults

**Transferable:** No

A class for older adults that will assist them in developing their writing skills through journal keeping. The students will discover the process of using structured exercises to write about their thoughts, feelings and stress responses in an effort to increase self-awareness and healthier living.

4876	LAB	COGMR	DASS R	2.00	.0	Tu	0300P-0500P
02/06/07 - 03/27/07 See Footnote: Above class meets Off Campus							

### ENGL 753 Writing Your Autobiography

**Transferable:** No

This class in creative writing for older adults will explore autobiography as a form of personal expression. Participants will put their experiences on paper. Learn the skills of autobiography including narrative structure, style, vocabulary, event recording and interpretation.

4875	LAB	MHG12	STAFF	4.00	.0	MW	0100P-0300P
04/02/07 - 05/02/07 See Footnote: Above class meets Off Campus							

### ENGL 754 Discover Your Family History for Older Adults

**Transferable:** No

This class will assist older adults in the research and writing of their family histories. They will collect names of relatives and establish relationships through primary, secondary and/or circumstantial evidence and/or documentation. Various sources for researching including Internet use will be encouraged.

4874	LAB	MHG5	STAFF	2.00	.0	MW	0100P-0300P
02/05/07 - 03/28/07 See Footnote: Above class meets Off Campus							

### ENGL 755 Art of Storytelling for Older Adults

**Transferable:** No

Bridge the generational gap and learn the ancient time-honored way of sharing cultural values and passing down history from one generation to the next. Storytelling is a valuable way to increase intergenerational understanding and unity and creates an opportunity for children and adults in the community to have their lives enriched by this creative activity. The class will provide training tips and the opportunity for older adults to volunteer their new skills in a community setting.

6505	LAB	SBCL	PIMENTEL A	1.10	.0	Th	0610P-0720P
02/01/07 - 06/07/07 See Footnote: Above class meets Off Campus							

## ENGL 756 GED Preparation

**Transferable:** No

This course is designed to prepare the student to pass the five General Education Development (GED) tests in Writing, Social Studies, Science, Literature and Mathematics. English grammar and usage, reading comprehension, writing, vocabulary and computational skills are emphasized. The course is designed for students who are 18 years of age or older and elect to take the High School Equivalency Examination.

6509	LAB	RANCHO	SEGOVIA M	3.00	.0	S	0100P-0400P
02/03/07 - 06/02/07 See Footnote: Above class meets Off Campus							
6510	LAB	SV001	STARR S	3.00	.0	S	0900A-1200P
02/03/07 - 06/02/07 See Footnote: Above class meets Off Campus							

## ENGLISH AS A SECOND LANGUAGE

### ESL 702A ESL Citizenship

**Transferable:** No

This course is designed for second language learners that want to prepare for the United States Citizenship test given by the Department of Immigration and U. S. Naturalization Services. The focus will be on communicative English skills and knowledge of American History and Government required for passing the test to become a citizen of the United States. Readings are at the high-beginning/low-intermediate ESL level and will focus on the historical period beginning in the 1600's on through to 1980.

6506	LEC	STFI	STUKER D	3.00	.0	MTh	0600P-0730P
01/29/07 - 06/14/07 See Footnote: Above class meets Off Campus							
6507	LEC	SOBRTO	GONZALES D	3.00	.0	TuTh	0600P-0730P
02/01/07 - 06/12/07 See Footnote: Above class meets Off Campus							
6508	LEC	RANCHO	SEGOVIA M	3.00	.0	W	0600P-0900P
01/31/07 - 06/06/07 See Footnote: Above class meets Off Campus							

### ESL 704A ESL for the Workplace

**Transferable:** No

This is part A of a content-based integrated skills course for ESL students who want to prepare for immediate entry into the job force. Students expand their language skills within the realm of the work world and specific vocational career of interest while also developing the soft skills needed in the workplace. This course is a combination of lecture, lab, and self-paced instruction.

4865	LAB	SV003	GONZALES D	10.00	.0	MTuWThF	0900A-1100A
01/29/07 - 05/31/07 See Footnote: Above class meets Off Campus							

## GUIDANCE

### GUID 710 Parent Advocacy

**Transferable:** No

This course is designed to help parents understand the transition from high school to college. Parents will develop techniques on how to better support their college student at home by creating a college going environment and increase potential involvement to enhance academic achievement. Parents will also develop a general understanding of the challenges and obstacles students face on a daily basis.

4888	LEC	LI100	GERUSA R	3.00	.0	MTuWTh	1230P-0330P
01/08/07 - 01/11/07							
6514	LEC	RANCHO	STAFF	2.00	.0	M	0600P-0800P
02/05/07 - 03/19/07 See Footnote: Above class meets Off Campus							

## HUMANITIES

### HUM 767 Film Classics

**Transferable:** No

This class is designed to study the facts, fantasy, history and trivia of classic and modern films. The background and history of each film and its performance will be compared and contrasted.

4860	LAB	HVME1	SWEENEY L	3.00	.0	W	0215P-0515P
01/31/07 - 05/09/07 See Footnote: Above class meets Off Campus							
4884	LAB	PLY	RICHARDS G	3.00	.0	W	1255P-0405P
01/31/07 - 06/06/07 See Footnote: Above class meets Off Campus							
4895	LAB	WM1	GERUSA R	3.00	.0	F	0100P-0400P
02/02/07 - 05/18/07 See Footnote: Above class meets Off Campus							

## LIBRARY

### LIB 730 Internet Literacy for Older Adults

**Transferable:** No

A class for older adults to learn email techniques, how to find information on their interests, news sources, and the skill of browsing online, as well as how best to use the local public library online services, online shopping, search strategies, and interactive games.

4633	LEC	SV002	HERNANDEZ A	4.00	.0	TuTh	0930A-1130A
02/06/07 - 03/06/07 See Footnote: Above class meets Off Campus							
4634	LEC	SV002	HERNANDEZ A	5.00	.0	TuTh	0930A-1130A
03/08/07 - 04/05/07 See Footnote: Above class meets Off Campus							
4635	LEC	MHG5	STAFF	4.00	.0	MW	1030A-1230P
02/05/07 - 03/07/07 Above class meets at Morgan Hill Community site							
4636	LEC	MHG5	STAFF	4.00	.0	MW	1030A-1230P
03/12/07 - 04/16/07 Above class meets at Morgan Hill Community site							
4637	LEC	HOL3	MENDEZ F	3.00	.0	MW	0130P-0300P
02/05/07 - 03/19/07 Above class meets at the Hollister Briggs site							
4638	LEC	HOL3	MENDEZ F	3.00	.0	MW	0130P-0300P
03/26/07 - 05/09/07 Above class meets at the Hollister Briggs site							

### LIB 731 Finding Book Treasures in Literature for Older Adults

**Transferable:** No

Older adults are guided in the reading of selected quality fiction and nonfiction to promote discussions of theme development, narrative techniques, social context and what makes good writing. Content varies from semester to semester and may include fiction, drama, poetry, essay, and biography. Readings selected may have particular relevance to older adults.

4855	LEC	MHG12	STAFF	2.00	.0	F	0100P-0300P
02/02/07 - 04/06/07 See Footnote: Above class meets Off Campus							

**LIB 732 Introduction to Online Gavilan**

**Transferable:** No

Introduction to the online classes and student services at Gavilan College. This course will show students how to log into their online courses, find lectures, assignments and exams, take part in online class discussions, submit attachments, and view their grades. The course will also cover all the online student services available to the distant student, including counseling, library resources, records and grades, financial aid, tutoring and technical support.

4864 ONLINE PARKER J 1.00 .0 DHR 0000-0000 38  
 01/31/07 - 05/25/07 This online class will be delivered entirely over the internet. After enrolling, start the class by going to <http://www.gavilan.edu/disted/>, click on your class link, and email the instructor at [jparker@gavilan.edu](mailto:jparker@gavilan.edu). Students who have not begun the class or contacted the instructor by 5 pm on the 3rd day of class will be dropped from the class.



**MUSIC**

**MUS 763 Music Encounters**

**Transferable:** No

A class for older adults that provides musical activities to stimulate and sustain their auditory function, discernment of sounds and manual dexterity. Students will enjoy music, new and old, by listening, singing, playing and creating music in a group setting.

4856	LEC	GHR1	MENDEZ F	1.00	.0	TuTh	0200P-0300P
02/06/07 - 05/03/07 See Footnote: Above class meets Off Campus							
4863	LEC	LOADCS	STAFF	1.00	.0	MW	0130P-0230P
01/29/07 - 04/30/07 See Footnote: Above class meets Off Campus							
4866	LEC	VPRH	SWEENEY L	2.00	.0	F	0100P-0300P
02/02/07 - 05/04/07 See Footnote: Above class meets Off Campus							
6503	LEC	GHS	ROBB P	2.00	.0	Tu	0730P-0945P
STAFF See Footnote: Above class meets Off Campus							
6504	LEC	SOLB7	STAFF	2.00	.0	W	0700P-0950P
See Footnote: Above class meets Off Campus							

**PHYSICAL EDUCATION:ADAPTED**

**PE 716 Music/Movement and Health**

**Transferable:** No

This course is designed to assist older adults in improving overall health through movement, music and relaxation techniques. Rhythmical movement will be adjusted to suit individual students mobility needs.

4773	LAB	GHR1	MENDONCA B	1.00	.0	MW	0200P-0300P
01/29/07 - 06/13/07 See Footnote: Above class meets Off Campus							
4774	LAB	HOLLCC	MENDEZ F	2.00	.0	Tu	1000A-1200P
02/06/07 - 06/12/07 See Footnote: Above class meets Off Campus							
4775	LAB	HVME1	MENDONCA B	2.00	.0	Th	1030A-1230P
02/01/07 - 06/07/07 See Footnote: Above class meets Off Campus							
4868	LAB	VPRH	ROTH R	1.00	.0	Tu	0100P-0300P
02/06/07 - 06/12/07 See Footnote: Above class meets Off Campus							
4869	LAB	YMCA	MENDONCA B	1.00	.0	TuF	1000A-1200P
02/02/07 - 06/15/07 See Footnote: Above class meets Off Campus							
4887	LAB	COGMR	MENDONCA B	1.00	.0	F	0100P-0300P
02/02/07 - 06/15/07 See Footnote: Above class meets Off Campus							

# Day of Beauty

for Men & Women

Includes:

- ✓ Hair cut & style
- ✓ Deep conditioning
- ✓ Scalp treatment
- ✓ Manicure
- ✓ Facial
- ✓ Eyebrow arch
- ✓ Makeup

*no substitutions*



only **\$30**  
w/o coupon - \$35

**DISCOUNTS**

Senior Citizens: 20% daily

Staff/Students: 10% daily

Discounts not applicable to DAILY

SPECIALS, Special perms or any service under \$6.00

**Spring/Fall hours**

Wed.-Fri. 10:30 am - 2:30 pm

**Summer hours**

Tu.-Th. 10:30 am - 3:30 pm

**DAILY SPECIALS**

**Wednesday:**

- Hair Cut ONLY - \$5
- Hair Cut & Style - \$10
- Hair Color - 20% off

**Thursday/Friday:**

- All Basic Perms - 20% off
- Plain Manicure & Pedicure - \$11

All work performed by students supervised by instructors  
 Discounts not applicable to daily specials, special color, special perms or any service under \$6. Not valid with any other discounts.

For appointments call 408-842-5055

## Off-Campus Buildings

- COGMR City of Gilroy (meeting room)
- GHR1 Gilroy Health Care and Rehabilitation, 8170 Murray Ave.
- GHS Gilroy High School
- HOL Hollister Briggs Bldg.
- HOLLCC Hollister Comm. Center (Jovenes de Antano), 300 West St., Hollister
- HVME1 Hacienda Valley Mobile Estates, 275 Burnett Ave., Morgan Hill
- LOADCS Live Oak Adult Day Care Services, 651 W. 6th St., Gilroy
- MHG Morgan Hill Community & Cultural Center
- PHM1 Pacific Hills Manor 370 Noble Court Morgan Hill, CA 95037
- PLY Morgan Hill Playhouse, Monterey Highway and Dunne, Morgan Hill
- RANCHO Rancho Park Apartments, 1200 Rancho Drive, Hollister
- SBCL San Benito County Library, 470 5th St., Hollister, 95023
- SOBRTO Sobrato Transitional Housing, Gilroy
- SOLB7 Solorsano Middle School, Gilroy, room B-7
- STFI St. Francis, 7950 Church St., Gilroy, 95020
- SV001-004 South Valley Middle School, Building I, 385 IOOF Ave., Gilroy
- VPRH Valley Pines Retirement Home, 545 E. Main Ave., Morgan Hill, 95037
- WM Wheeler Manor, 651 W. 6th St., Gilroy
- YMCA Morgan Hill YMCA, 17666 Crest Ave., Morgan Hill 95037

**Spring classes begin January 31, 2007  
REGISTER EARLY!**



# ROP Courses

Regional Occupational Program (ROP) training is offered to residents of Santa Clara and San Benito Counties by the Santa Clara County Office of Education. Some classes are offered at Gavilan College. In some of the classes, students may earn high school or college credit, and upon completion they may be eligible for advanced placement at Gavilan College. ROP provides students with training to secure jobs, upgrade skills, or prepare for advanced career education. Students must be 16 years of age or older to participate. Classes are free for both high school students and adults. Gavilan College fees are charged for Gavilan College credit. ROP classes may have additional fees for textbooks and supplies. For information on ROP courses taught at Gavilan College, call 408-848-4816.

Students enrolled in ROP classes do not qualify for Financial Aid.

## ROP Accounting

### General Office Accounting

**Advisory:** Eligible for Mathematics 205.

This course is designed to prepare students for entry-level office accounting positions. Emphasis is on practical accounting applications. This course has the option of a letter grade or credit/no credit. For college credit, enroll in Gavilan's ACCT 103.

Room	Instructor	Day	Time	Footnotes
BU118	COLLEGE A	F	0900A-1210A	96

### Introduction to Income Tax

**Advisory:** Eligible for English 250, English 260 and Mathematics 205.

A study of theory, philosophy, and principles of income tax law and procedures for computing the tax liability. It includes practice in solving typical individual tax problems. This course has the option of a letter grade or credit/no credit. For college credit, enroll in Gavilan's ACCT 111.

Room	Instructor	Day	Time	Footnotes
BU120	BARTAM	MW	0810A-0935A	96

### Computerized Accounting - QuickBooks

**Advisory:** CSIS 1 or CSIS 2 or the equivalent computer experience. ACCT 20 or ACCT 101 or ACCT 103 or ACCT 105 or the equivalent accounting experience.

An introduction to computer-assisted accounting. Hands-on use of a microcomputer menu-driven accounting package to do general ledger, sales journal, cash receipts journal, cash payments journal, purchases journal, payroll, receivables, payables and related financial reports. This course has the option of a letter grade or credit/no credit. Repeatable whenever a new software package is adopted. For college credit, enroll in Gavilan's ACCT 120 or CSIS 120.

Room	Instructor	Day	Time	Footnotes
BU111	BARTAM	W&1.4	0945A-1240P	25 35 96

## ROP Computer Applications

### Computer Office Applications

Two computer office application courses will be offered. The **afternoon** course will offer **intermediate** and **advanced** word processing. The **evening** course will offer **basic** word processing. Both courses offer business skills and concepts with hands-on experience. Software includes: Word, Excel, and PowerPoint.

Room	Instructor	Day	Time
HOL 3	HERNANDEZ A	TuTh	12:30 P-3:50 P
Above class meets at Hollister Briggs site			
L1171	OLES C	M	6:00 P- 9:20 P

### Computerized Accounting - QuickBooks

**Advisory:** CSIS 1 or CSIS 2 or the equivalent computer experience. ACCT 20 or ACCT 101 or ACCT 103 or ACCT 105 or the equivalent accounting experience.

An introduction to computer assisted accounting. Hands-on use of a microcomputer menu-driven accounting package to do general ledger, sales journal, cash receipts journal, cash payments journal, purchases journal, payroll, receivables, payables and related financial reports. This course has the option of a letter grade or credit/no credit. Repeatable whenever a new software package is adopted. For college credit, enroll in Gavilan's ACCT 120 or CSIS 120.

Room	Instructor	Day	Time	Footnotes
MHG5	BARTAM	M&1.4	0630P-0940P	25 35 96
Above class meets at Morgan Hill Community site				

## ROP Administrative Medical Assisting

### Medical Terminology

**Advisory:** Eligible for English 250 and English 260.

This course introduces fundamentals of medical word building used in the health profession (prefixes, word roots, suffixes and abbreviations) as well as review of body systems, with emphasis on analysis, definition, spelling and pronunciation. This course has the option of a letter grade or credit/no credit. For college credit, enroll in Gavilan's BOT 180.

Room	Instructor	Day	Time	Footnotes
BU120	KNAPP D	Th	0600P-0910P	96

### Medical Billing - MediSoft

**Advisory:** Eligible for English 250. Some computer experience.

This course in computerized billing procedures for a medical office uses MediSoft software. Students will learn the patient billing features of this software and complete a capstone simulation giving them hands-on realistic medical front office practice. This course has the option of a letter grade or credit/no credit. For college credit, enroll in Gavilan's BOT 181.

Room	Instructor	Day	Time	Footnotes
BU110	KNAPP D	M&1.4	0600P-0910P	35 96



## Short-term Training Program **ROP Dental Assisting**

Includes Radiology (X-Ray) Certification

January 29, 2007 - June 22, 2007  
Mon-Fri, 9:30 am - 3:00 pm

**Location:** ROP-South, 700 W. 6th St., Ste. L, Gilroy

**Registration:** Doors open at 7:30 am and registration begins promptly at 8:00 am

**Cost:** \$210 includes book and lab fee. Students must purchase lab coats.

Call (408) 842-0361 for more information.

*This course includes instruction in chairside assisting as well as x-ray certification.*

### Medical Office Procedures

**Prerequisite:** BOT 180 and CSIS 126 with credit or a grade of C or better or experience using Microsoft Word.

**Advisory:** Eligible for English 250 and Mathematics 402.

This specialized course includes medical office procedures, patient record management, coding/billing for private/government health insurance programs, and professional ethics. May be repeated three times for credit. This course has the option of a letter grade or credit/no credit. For college credit, enroll in Gavilan's BOT 182.

Room	Instructor	Day	Time	Footnotes
BU110	KNAPP D	W&1.4	0600P-0910P	35 96

### ROP Clinical Medical Assisting

### Advanced Clinical Medical Assisting

**Prerequisite:** AH 170 with a grade of C or better or equivalent. Equivalency determined by written and performance exams.

Course provides instruction and clinical experience in advanced concepts of clinical medical assisting including specialty procedures and treatments. For college credit, enroll in Gavilan's AH 171.

Room	Instructor	Day	Time	Footnotes
HOB114	KEARBAY A	TuWTh	0100P-0440P	96

### ROP Nursing Assistant

### Fundamentals of Nursing—Convalescent

**Prerequisites:** Eligible for English 250 and English 260. Clearance from the Department of Health Services (Form HS283), fingerprint card, and health clearance required prior to clinical placement.

A course to provide a basic introduction to patient care in the convalescent setting. Emphasizes principles, understanding and skills necessary to perform basic nursing procedures safely and effectively. Includes introduction to health care, planning, safety, infection control, personal care, basic procedures, rehabilitation, nutrition and clients' rights and needs. At the completion of this course students will qualify for state certification as a nursing assistant. For college credit, enroll in Gavilan's AH 180.

Room	Instructor	Day	Time	Footnotes
HOB114	MACHADO M	MTu	0900A-1200P	92 94 96
	MACHADO M	W	0630A-0130P	
HOB114	MACHADO M	MTu	0900A-1200P	92 94 96
	MACHADO M	Th	0630A-0130P	
HOB114	MACHADO M	MTu	0900A-1200P	92 94 96
	MACHADO M	F	0630A-0130P	

## Additional **ROP** sites in the Gavilan College District

All day classes offered at high school locations are part of the regular high school schedule. Adults are admitted on a space-available basis by contacting the high schools.

**ROP Instructional Services Gilroy**  
**408-842-0361**  
Dental Assisting

**Anzar High School**  
**408-623-7660**  
Audio Video Publishing  
Photography

**Gilroy High School**  
**408-847-2424**  
Auto Technology  
C.A.D. Drafting  
Commercial Photography  
Computer Bus. Application  
Criminal Justice  
Digital Design and Animation  
Horticulture-Ornamental  
Sports Medicine I & II  
Veterinary Medicine  
Visual Communications

**Live Oak High School**  
**408-201-6129 or 408-201-6111**

Agriculture Sales/Services  
Cabinet Making  
Careers with Children  
CISCO Networking  
Fashion Design  
Graphic Technology  
Photography, Commercial  
Technical Writing  
Veterinary Science  
Web Design

**San Andreas High School**  
**Call 831-637-9269**  
Computer Bus. Appl.

**San Benito High School**  
**831-637-5831, ext. 185**  
Ag. Fabrication-Construction  
Audio Video Publishing  
Auto Mechanics  
C.A.D. Drafting  
Cabinet Making  
Child Care  
Commercial Art  
Computer Accounting  
Computer Programming  
Computer Repair  
Computerized Bus. Appl.  
Food Service/Restaurant Careers  
Marketing  
Metals Fabrication  
Sports Medicine  
Technical Writing

**Sobrato High School**  
**408-201-6200**  
Ag Sales  
Biotechnology  
Commercial Photography  
Sports Medicine  
Veterinary Science  
Web Design  
Welding

# DISTANCE LEARNING

Distance education courses at Gavilan are offered in three different ways:

- Online courses
- Online Hybrid
- Telecourses



Hybrid - online  
and classroom



Telecourses

## Online Courses at Gavilan College

Online courses allow students who have access to a computer and modem to take college credit classes. Students need to have access to an individual email account and the World Wide Web. Students enrolled in these Internet-delivered classes will meet with their instructors and with their classmates through the Internet. The majority of coursework is done online. However, one or more on-campus meetings may be required. If this is a problem, you may contact your instructor for possible accommodations.

After enrolling, start the class by going to <http://www.gavilan.edu/disted/> and clicking on your class.

It is your responsibility to log into the class by the end of the fourth day (semester-long courses) or by the third day (short-term classes). Students who have not logged into the class by the deadline will be dropped from the course.

**Orientations:** We strongly recommend that students take one of the live orientations to online courses offered in the Gavilan Library. Please see the library homepage at: <http://www.gavilan.edu/library/> for a schedule of orientations or you may make a personal appointment with one of the librarians by calling 408-848-4806.

We encourage you to exercise the same kind of caution in a distance learning class as you would if you were taking an on-site class. Do not share personal information about yourself; do not give a stranger or new acquaintance your home phone number or address.

SECT	COURSE	DESCRIPTION	INSTRUCTOR	UNITS	BEGIN/END
<b>INTERSESSION</b>					
4892	CSIS 3	RESEARCH SKILLS	YOUNG D	2.0	1/03-2/23
4893	LIB 3	RESEARCH SKILLS	YOUNG D	2.0	1/03-2/23
<b>EARLY START</b>					
4881	CSIS 10	BASIC PROGRAMMING	VANTASSEL D	2.0	12/18-1/31
4882	CSIS 84	JAVASCRIPT PROGRAM	VANTASSEL D	2.0	12/18-1/31
<b>SPRING SEMESTER</b>					
4033	AH 3	PERSON/LIFE CYCLE	BEDELL K	3.0	1/31-5/25
4036	AH 11	NUTRITION	AKROP M	3.0	1/31-5/25
4080	ANTH 1	INTRO PHYSICAL ANTH	KLEIN D	3.0	1/31-5/25
4091	ART 6	ART APPRECIATION	EDBERG J	3.0	1/31-5/25
4124	ART 140	BASIC DIGITAL FILM/VIDEO	BEEDE R	1.0	1/31-5/25
4145	BIO 11	NUTRITION	AKROP M	3.0	1/31-5/25
4224	CSIS 5	C++ SCIENTIFIC PROG	VANTASSEL D	3.0	1/31-5/25
4225	CSIS 6	WEBPAGE AUTHORING I	HOWELL J	2.0	1/31-3/24
4230	CSIS 12	ASSEMBLY LANGUAGE	VANTASSEL D	3.0	2/05-5/21
4890	CSIS 12L	ASSEMBLY LANG LAB	VANTASSEL D	1.0	1/31-5/25
4231	CSIS 45	C++ PROGRAMMING I	VANTASSEL D	4.0	1/31-5/25
4232	CSIS 48	UNIX/LINUX OP. SYS	VANTASSEL D	4.0	1/31-5/25
4233	CSIS 51	VISUAL BASIC .NET	TARVIN J	4.0	1/31-5/25
4896	CSIS 54	PERL PROGRAMMING	HOWELL P	3.0	1/31-5/25
4891	CSIS 54L	PERL PROGRAMMING LB	HOWELL P	1.0	1/31-5/25
4260	CSIS 140	BASIC DIGITAL FILM/VIDEO	BEEDE R	1.0	1/31-5/25
4277	DM 6	WEBPAGE AUTHORING I	HOWELL J	2.0	1/31-3/24
4295	DM 140	BASIC DIGITAL FILM/VIDEO	BEEDE R	1.0	1/31-5/25
4313	ENGL 1A	COMPOSITION	HESSE D	3.0	1/31-5/25
4314	ENGL 1A	COMPOSITION	CHAFFIN C	3.0	1/31-5/25
4321	ENGL 1B	COMPOSITION & LIT	WISDOM K	3.0	1/31-5/25
4322	ENGL 1B	COMPOSITION & LIT	WARREN K	3.0	1/31-5/25
4328	ENGL 1C	CRITIC REASON/WRITE	CANDELARIA X	3.0	1/31-5/25
4330	ENGL 4B	BRITISH LITERATURE	JAMES R	3.0	1/31-5/25
4425	GUID 1	SELF ASSESSMENT	SHARBONEAU	2.0	1/31-5/25
4426	GUID 1	SELF ASSESSMENT	SHARBONEAU	2.0	1/31-5/25
4451	HE 2	HUMAN SEXUALITY	QUATRE S	3.0	2/01-5/25
4630	LIB 6	WEBPAGE AUTHORING I	HOWELL J	2.0	1/31-3/24
4864	LIB 732	INTRO TO ONLINE GAVILAN	PARKER J	0.0	1/31-5/25
4644	MATH 5	INTRO STATISTICS	HUBBARD M	3.0	1/31-5/25
4681	MUS 1A	MUSIC HISTORY/LIT	BENKMAN N	3.0	1/31-5/25
4788	POLS 1	INTRO AMERICAN GOVERNMENT	TURETZKY M	3.0	1/31-5/25
4796	PSCI 2	INTRO METEOROLOGY	VANTUYL A	3.0	1/31-5/25
4807	PSYC 5	SELF ASSESSMENT	SHARBONEAU	2.0	1/31-5/25
4808	PSYC 5	SELF ASSESSMENT	SHARBONEAU	2.0	1/31-5/25
4828	SPAN 12A	SPAN/SPAN SPEAKERS	SCHMIDT E	5.0	1/31-5/25
4829	SPAN 12B	SPAN/SPAN SPEAKERS	PEREZ D	5.0	1/31-5/25
<b>LATE START "CYBERSESSION"</b>					
4228	CSIS 8	INTRO TO INTERNET	VENABLE E	1.0	3/05-4/27
4044	AH 140	INFO COMP/HEALTH	MEADER S	2.0	3/26-5/21
4226	CSIS 6	WEBPAGE AUTHORING I	VENABLE E	2.0	3/26-5/21
4237	CSIS 84	JAVASCRIPT PROGRAM	STAFF	2.0	3/26-5/25
4278	DM 6	WEBPAGE AUTHORING I	VENABLE E	2.0	3/26-5/21
4631	LIB 6	WEBPAGE AUTHORING I	VENABLE E	2.0	3/26-5/21
4632	LIB 140	ONLINE HEALTH RESEARCH	MEADER S	2.0	3/26-5/21
4894	THEA 20	INTRO TO SCRIPTWRITING	ABAD M	3.0	3/19-5/25

## Hybrid Courses

Hybrid courses are a combination of traditional meetings and online meetings. Typically you will meet in a regular classroom once a week, and meet online once a week. You'll get the convenience of online courses, but have the advantage of meeting with your instructor and classmates too. See individual webpages for these classes for details.

SECT	COURSE	DESCRIPTION	INSTRUCTOR	UNITS	BEGIN/END
6016	ART 10A	CULTURAL HISTORY OF CERAMICS	GONZALES KC	3.0	2/03-5/19
6028	BIO 15	SURVEY ANAT/PHYSIOL	MORALES R	5.0	1/31-5/23
6051	CMUN 11	BUSINESS COMMUNICATION	WADDELL E	3.0	2/5-5/21
4221	CSIS 2	COMPUTERS IN BUSINESS - MS OFFICE	VENABLE E	4.0	2/6-5/22
4889	CSIS 2	COMPUTERS IN BUSINESS - MS OFFICE	VENABLE E	4.0	2/2-5/25
4790	POLS 4	INTRO/INTL RELATION	TURETZKY M	3.0	2/05-5/21
4835	THEA 3	EL TEATRO CAMPESINO	CARDINALLI J	3.0	3/19-5/25

Thinking of online courses at Gavilan College?

Take LIB 732 first!

### INTRODUCTION TO ONLINE GAVILAN

A FREE introduction to the world of online education, ONLINE!

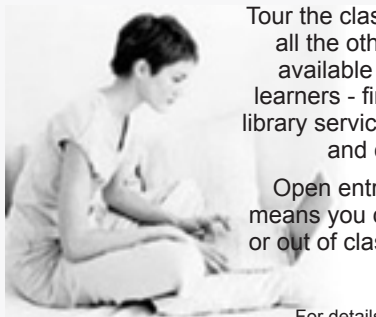

Tour the classroom and all the other services available to distance learners - financial aid, library services, tutoring and counseling.

Open entry/open exit means you can jump in or out of class any time you want.

For details see page 43.

## Telecourses at Gavilan College

Telecourses are presented through a set of videos, which means that students must have access to a television and vcr. The videos can be viewed on cable TV (Charter TV, channel 18) or on cassettes. There will be some required meetings for class; check the course listing for details.

If you have any questions, please call Jo Anne Howell, the Distance Learning Coordinator, at 408-848-4885, or email her at [jhowell@gavilan.edu](mailto:jhowell@gavilan.edu).

Telecourse delivery is through Gavilan Channel 18, Morgan Hill MHAT Channel 18 or video tape. \$22 materials fee payable at registration and \$25 refundable security deposit required.

### sect. 6519 HUM 4 INTRO TO AMER CINEMA

Instructor: Grant Richards  
SS 214 3 units TH 6:30 - 9:40 pm

This telecourse will have three required on-campus meetings: Thursdays, Feb. 1, March 22 and May 24, 2007. Orientation for the course will be provided at the first class meeting.

NOTE: You must attend the first session (orientation) in order to enroll in the following course.

## San Jose State University Telecourses at Gavilan College - Spring 2007

San Jose State University classes begin Wednesday, January 24, 2007. Last day of instruction: Tuesday, May 15.

There is a \$25 site fee per class to be paid to Gavilan College.

Classes meet in OE103.

To register for television classes or for more information on dates, times and admission fees, contact: Gavilan College 408-848-4719 or SJSU 408-924-3624.

SECT	TIME	COURSE	TIME	INSTRUCTOR
EDCO 286	M	Theory of Org. Change	4-6:45PM	Davidson-Cathey
EDCO 221	M	Research Sem in Education	7-9:45PM	Oliver
EDCO 267	T	Practice in Life Span Career	4-6:45PM	Ogimachi-Capizzi
EDCO 232	T	Law and Ethics for Counselors	7-9:45PM	Berta
EDCO 248	W	Dyn of Behavior & Dvlpmnt	4-6:45PM	Mratz
EDCO 215	W	Into to Counseling & Guidance	7-9:45PM	Mratz
EDCO 282	TH	Edu. Assessment for Counseling	4-6:45PM	Aptekar
EDCO 227	TH	Dynamic of Comm-School relations	7-9:45PM	Gonzalez



## Weekend Courses

The following courses are offered on weekend days at the Gavilan sites in Morgan Hill, Hollister and on the main campus. Students may register at any site, by telephone or in person. Spring courses are described beginning on page 58.

### Main Campus, Gilroy

SECT	COURSE	DESCRIPTION	UNITS	BEGIN	DAY	TIMES	ROOM
6007	AH 32	BASIC CARD/LIFE SUP	1.0	2/10-2/11	SAT/SUN	800A-500P	HOB114
6008	AH 32	BASIC CARD/LIFE SUP	1.0	3/03-3/04	SAT/SUN	800A-500P	HOB114
6016	ART 10A	CULT HIST CERAMICS	3.0	2/03-5/19	SAT	900A-1210P	AR101
6029	BIO 21	FIELD ECOLOGY	1.0	4/16-4/28	SAT	800A-600P	LS101
6047	CD 160	CHILD CARE 1ST AID	1.0	2/02-2/09	F	600P-910P	CD127
					SAT	900A-400P	CD127
6045	CD 28B	DEV LEARNING ACTIVI	1.0	4/27-5/05	F	600P-850P	CD127
					SAT	900A-400P	CD127
6513	CSIS 54	PERL PROGRAMMING	3.0	2/03-5/19	SAT	900A-1200P	BU110
6064	CSIS 54L	PERL PROGRAMMING LB	1.0	2/03-5/19	SAT	1200P-100P	BU110
6091	ENGL 1A	COMPOSITION	3.0	2/03-5/19	SAT	900A-1210P	HU102
6510	ENGL 756 <sup>*/**</sup>	GED PREPARATION	0.0	2/03-6/02	SAT	900A-1200P	SV001
6119	GUID 28	TUTORING TECHNIQUE	1.0	2/23-4/06	SAT	930A-230P	LI116
6162	PE 17	GOLF	0.5	3/31-5/19	SAT	900A-1200P	GY200C

\* Noncredit class. See pages 40-43.

\*\* Off campus location. See page 31.

### Morgan Hill and Hollister

6039	CD 11C	SUPERVISION OF ADLT	2.0	2/24-3/31	SAT	800A-400P	MHG4
6522	CD 5	CHILD/FAMILY/COMMUN	3.0	2/03-5/19	SAT	900A-300P	MHG11
6512	CMUN 129	PRESENTATN GRAPHICS	1.0	1/06-2/03	SAT	830A-1220P	MHG8
6058	CSIS 12	ASSEMBLY LANGUAGE	3.0	2/10-5/19	SAT	900A-1220P	MHG8
6518	CSIS 12L	ASSEMBLY LANG LAB	1.0	2/10-5/19	SAT	1200P-100P	MHG8
6059	CSIS 23	INDEPENDENT STUDY	1.0	2/04-5/20	SUN	400P-800P	MHG8
6071	CSIS 122	COMPUTER KEYBOARD	1.0	2/10-5/19	SAT	830A-1220P	MHG5
6070	CSIS 122	COMPUTER KEYBOARD	0.5	2/10-5/19	SAT	830A-1220P	MHG5
6076	CSIS 124	WINDOWS FUNDAMENTAL	1.0	2/17-3/17	SAT	830A-1220P	MHG5
6078	CSIS 126	WORD PROCESS-MS WRD	2.0	3/24-5/19	SAT	830A-1220P	MHG5
6511	CSIS 129	PRESENTATN GRAPHICS	1.0	1/06-2/03	SAT	830A-1220P	MHG8
6088	ECON 2	PRIN MICROECONOMICS	3.0	2/03-5/19	SAT	900A-1205P	MHG3
6090	ECON 14	PERSONAL FINANCE	3.0	2/03-5/19	SAT	800A-1105A	MHG12
6520	GBUS 14	PERSONAL FINANCE	3.0	2/03-5/19	SAT	800A-1105A	MHG12
6009	AH 740 <sup>*/**</sup>	TAI CHI ARTHRITIS	0.0	2/03-6/02	SAT	1045A-1145A	HHH1
6509	ENGL 756 <sup>*/**</sup>	GED PREPARATION	0.0	2/03-6/02	SAT	100P-400P	RANCHO

## Late Afternoon and Evening Courses

### Main Campus, Gilroy

SECT	COURSE	DAY	TIME	SECT	COURSE	DAY	TIME	SECT	COURSE	DAY	TIME
6003	ACCT 21	T	545P-950P	4366	ENGL 250	M W	400P-525P	* 6153	MUS 13	T	630P-940P
6012	AJ 176	T	600P-910P	4367	ENGL 250	M W	400P-525P	* 6154	MUS 14A	W	640P-950P
6017	ART 10A	T T	600P-830P	6102	ENGL 250	M W	700P-905P	* 6155	MUS 14B	W	640P-950P
6018	ART 10B	T T	600P-910P	6103	ENGL 260	M W	530P-655P	* 6156	MUS 14C	W	640P-950P
* 4097	ART 14	W	315P-720P	6104	ENGL 420	T T	530P-735P	* 6157	MUS 14D	W	640P-950P
6024	ART 98	T T	600P-850P	6105	ENGL 440	T T	740P-945P	6158	MUS 23	M	600P-850P
6031	BOT 180	T	600P-910P	* 4876	ENGL 752	T	300P-500P	* 6159	MUS 26	W	640P-950P
6032	BOT 181	M	600P-910P	* 6506	ESL 702A	M T	600P-730P	6161	MUS 98	W	730P-945P
6033	BOT 182	W	600P-910P	6116	GBUS 11	M W	600P-805P	* 6160	MUS 98	T	730P-945P
6037	CD 4	M	600P-910P	6118	GBUS 80	M	630P-940P	* 6504	MUS 763	W	700P-950P
6045	CD 28B	F	600P-850P	6121	HIST 4A	T	600P-910P	* 6503	MUS 763	T	730P-945P
6046	CD 30B	W	600P-910P	6519	HUM 4	T	630P-940P	* 6503	MUS 763	T	730P-945P
6047	CD 160	F	600P-910P	6523	JPN 1B	T T	530P-800P	6163	PE 39	M	630P-940P
6048	CHEM 30A	T	600P-905P	6132	MATH 1A	M W	630P-835P	4746	PE 46	MTWT	310P-400P
6048	CHEM 30A	T	600P-905P	6133	MATH 5	T	630P-730P	4745	PE 46	MTWT	310P-400P
4198	CMUN 8	T T	400P-525P			T	735P-840P	6164	PE 61	T T	515P-640P
6051	CMUN 11	M	600P-910P			T	630P-835P	4787	POLS 1	T	310P-620P
6054	CSIS 1	W	600P-950P	6135	MATH 8A	M W	630P-835P	6169	POLS 1	M	630P-940P
6055	CSIS 2L	T	600P-950P	6137	MATH 205	M W	630P-900P	* 4802	PSYC 1A	M	310P-620P
6056	CSIS 5	T	600P-950P	6139	MATH 205B	T T	630P-835P	6171	PSYC 1A	M	600P-910P
6060	CSIS 45	T	600P-950P	4668	MATH 233	MTWT	400P-510P	6174	RE 160	M	630P-940P
6065	CSIS 61	T	600P-950P	6141	MATH 233	T T	630P-900P	6175	RE 167	T	630P-940P
6516	CSIS 121	TWT	600P-950P	6142	MATH 400	M W	630P-835P	6177	SOC 21	T	630P-940P
6075	CSIS 122	T	600P-850P	6144	MUS 4A	M	630P-940P	6182	THEA 13A	MTWT	630P-940P
6074	CSIS 122	T	600P-850P	6145	MUS 4B	M	630P-940P	6183	THEA 13B	MTWT	630P-940P
* 6080	CSIS 126	W	600P-910P	6146	MUS 5A	M	630P-940P	6184	THEA 13C	MTWT	630P-940P
6083	CSIS 181	W	600P-950P	6147	MUS 5B	M	630P-940P	6185	THEA 13D	MTWT	630P-940P
6084	CSIS 182	T	600P-950P	6148	MUS 5C	M	630P-940P				
6087	ECON 1	T	600P-910P	6149	MUS 5D	M	630P-940P				
6089	ECON 11	M W	600P-805P	6150	MUS 9A	M	530P-840P				
6097	ENGL 2C	W	630P-940P	6151	MUS 9B	M	600P-910P				
				* 6152	MUS 12	T	630P-940P				

\* Off campus location, See page 31.

700 Series classes are Noncredit. See page 41.

### Morgan Hill

SECT	COURSE	DAY	TIME	SECT	COURSE	DAY	TIME
* 4062	AJ 10	T	330P-630P	6006	ACCT 120	M	630P-940P
6001	ACCT 20	T	550P-950P	6001	ACCT 20	T	550P-950P
6010	AJ 18	M	630P-940P	6010	AJ 18	M	630P-940P
6011	AJ 20	W	630P-940P	6011	AJ 20	W	630P-940P
6014	ART 1A	W	630P-940P	6014	ART 1A	W	630P-940P
6022	ART 74	T	630P-940P	6022	ART 74	T	630P-940P
6023	ART 75	T	630P-940P	6023	ART 75	T	630P-940P
6025	ASTR 1	T	630P-940P	6025	ASTR 1	T	630P-940P
6035	CD 1	M	630P-940P	6035	CD 1	M	630P-940P
6041	CD 1	T	600P-910P	6041	CD 1	T	600P-910P
6049	CMUN 10	W	630P-940P	6049	CMUN 10	W	630P-940P
6061	CSIS 48	M	600P-950P	6061	CSIS 48	M	600P-950P
6062	CSIS 51	T	600P-950P	6062	CSIS 51	T	600P-950P
6066	CSIS 74	T	630P-940P	6066	CSIS 74	T	630P-940P
6067	CSIS 75	T	630P-940P	6067	CSIS 75	T	630P-940P
6068	CSIS 120	M	630P-940P	6068	CSIS 120	M	630P-940P
6082	CSIS 128	W	600P-955P	6082	CSIS 128	W	600P-955P
6085	DM 74	T	630P-940P	6085	DM 74	T	630P-940P
6086	DM 75	T	630P-940P	6086	DM 75	T	630P-940P
6094	ENGL 1A	T	630P-940P	6094	ENGL 1A	T	630P-940P
6106	ESL 501A	M WT	600P-735P	6106	ESL 501A	M WT	600P-735P
* 6507	ESL 702A	T T	600P-730P	* 6507	ESL 702A	T T	600P-730P
* 6508	ESL 702A	W	600P-900P	* 6508	ESL 702A	W	600P-900P
* 6514	GUID 710	M	600P-800P	* 6514	GUID 710	M	600P-800P
6134	MATH 5	M W	630P-835P	6134	MATH 5	M W	630P-835P
6138	MATH 205	T T	630P-900P	6138	MATH 205	T T	630P-900P
6165	PE 62	M W	500P-625P	6165	PE 62	M W	500P-625P
6172	PSYC 1A	T	600P-910P	6172	PSYC 1A	T	600P-910P
6179	SPAN 8A	M	630P-940P	6179	SPAN 8A	M	630P-940P

\* Off campus location, See page 31.

700 Series classes are Noncredit. See page 41.

### Hollister

SECT	COURSE	DAY	TIME	SECT	COURSE	DAY	TIME
6004	ACCT 103	W	600P-910P	6004	ACCT 103	W	600P-910P
6502	ACCT 120	F	530P-840P	6502	ACCT 120	F	530P-840P
6020	ART 25A	F	400P-815P	6020	ART 25A	F	400P-815P
6036	CD 3	M	600P-910P	6036	CD 3	M	600P-910P
6038	CD 9	T	600P-910P	6038	CD 9	T	600P-910P
6042	CD 13	T	600P-910P	6042	CD 13	T	600P-910P
6521	CD 25A	F	400P-815P	6521	CD 25A	F	400P-815P
6050	CMUN 10	T	600P-910P	6050	CMUN 10	T	600P-910P
6053	CSIS 1	T	600P-950P	6053	CSIS 1	T	600P-950P
6515	CSIS 120	F	530P-840P	6515	CSIS 120	F	530P-840P
6069	CSIS 121	W	555P-955P	6069	CSIS 121	W	555P-955P
6072	CSIS 122	M	600P-850P	6072	CSIS 122	M	600P-850P
6073	CSIS 122	M	600P-850P	6073	CSIS 122	M	600P-850P
6077	CSIS 124	T	600P-950P	6077	CSIS 124	T	600P-950P
6517	CSIS 126	T	600P-950P	6517	CSIS 126	T	600P-950P
6093	ENGL 1A	T	630P-940P	6093	ENGL 1A	T	630P-940P

# Late Start/Short Term

The following courses are offered at Gavilan's sites in Morgan Hill, Hollister and on the main campus in Gilroy. Students may register at any location until the last working day before the course begins. Spring courses are described beginning on page 58.

### Hollister

SECT	COURSE	UNITS	DATES	DAYS	TIMES	ROOM
4255	CSIS 124	1.0	2/05-3/07	M W	1120A-125P	HOL3
6514	GUID 710 **	0.0	2/05-3/19	M	600P-800P	RANCHO
4637	LIB 730 *	0.0	2/05-3/19	M W	130P-300P	HOL3
4218	CSIS 1	2.0	2/05-4/04	M W	900A-1105A	HOL3
4251	CSIS 122	0.5	2/05-5/14	M W	1120A-125P	HOL3
6053	CSIS 1	2.0	2/06-4/03	Tu	600P-950P	HOL3
6077	CSIS 124	1.0	2/08-3/08	Th	600P-950P	HOL3
6502	ACCT 120	2.0	2/09-5/18	F	530P-840P	HOL3
6517	CSIS 126	2.0	3/15-5/17	Th	600P-950P	HOL3
6069	CSIS 121	2.0	3/21-5/09	W	555P-955P	HOL3
4638	LIB 730	0.0	3/26-5/09	M W	130P-300P	HOL3
4202	CMUN 129	1.0	4/18-5/16	M W	900A-1105A	HOL3
4258	CSIS 129	1.0	4/18-5/16	M W	900A-1105A	HOL3

\* Noncredit class. See pages 40-43.      \*\* Off campus location. See page 31.

### Morgan Hill

SECT	COURSE	UNITS	DATES	DAYS	TIMES	ROOM
054	AH 740 **	0.0	2/01-4/03	Tu Th	1000A-1100A	PHM1
4244	CSIS 121	2.0	2/01-4/26	Th	1120A-225P	MHG8
4855	LIB 731 *	0.0	2/02-4/06	F	100P-300P	MHG12
4866	MUS 763 **	0.0	2/02-5/04	F	100P-300P	VPRH
4635	LIB 730 *	0.0	2/05-3/07	M W	1030A-1230P	MHG5
4874	ENGL 754 *	0.0	2/05-3/28	M W	100P-300P	MHG5
4120	ART 85	2.0	2/06-5/01	Tu	1120A-225P	MHG8
4238	CSIS 85	2.0	2/06-5/01	Tu	1120A-225P	MHG8
4288	DM 85	2.0	2/06-5/01	Tu	1120A-225P	MHG8
6058	CSIS 12	3.0	2/10-5/19	SAT	900A-1200P	MHG8
6070	CSIS 122	0.5	2/10-5/19	SAT	830A-1220P	MHG5
6071	CSIS 122	1.0	2/10-5/19	SAT	830A-1220P	MHG5
6518	CSIS 12L	1.0	2/10-5/19	SAT	1200P-100P	MHG8
6076	CSIS 124	1.0	2/17-3/17	SAT	830A-1220P	MHG5
6039	CD 11C	2.0	2/24-3/31	SAT	800A-400P	MHG4
4636	LIB 730 *	0.0	3/12-4/16	M W	1030A-1230P	MHG5
6082	CSIS 128	2.0	3/14-5/16	W	600P-955P	MHG8
6078	CSIS 126	2.0	3/24-5/19	SAT	830A-1220P	MHG5
4875	ENGL 753 *	0.0	4/02-5/02	M W	100P-300P	MHG12
4055	AH 740 **	0.0	4/05-6/12	Tu Th	1000A-1100A	PHM1
4227	CSIS 8	1.0	5/03-5/22	Tu Th	1120A-1240P	MHG8

\* Noncredit class. See pages 40-43.      \*\* Off campus location. See page 31.

### Online

SECT	COURSE	UNITS	DATES
4228	CSIS 8	1.0	3/05-4/27
4835	THEA 3	3.0	3/19-5/25
4894	THEA 20	3.0	3/19-5/25
4044	AH 140	2.0	3/26-5/21
4226	CSIS 6	2.0	3/26-5/21
4278	DM 6	2.0	3/26-5/21
4632	LIB 140	2.0	3/26-5/21
4631	LIB 6	2.0	3/26-5/21
4237	CSIS 84	2.0	3/26-5/25

### Main Campus, Gilroy

SECT	COURSE	CLASS	UNITS	DATES	DAYS	TIMES	ROOM
4219	CSIS 1	COMPUTER LITERACY	2.0	2/01-3/22	Tu Th	900A-1105A	BU120
4871	AH 740 **	TAI CHI ARTHRITIS	0.0	2/01-4/03	Tu Th	1000A-1100A	WM1
6047	CD 160	CHILD CARE 1ST AID	1.0	2/02-2/09	SAT	900A-400P	CD127
6047	CD 160	CHILD CARE 1ST AID	1.0	2/02-2/09	F	600P-910P	CD127
4243	CSIS 121	SPREADSHEET-MS EXCL	2.0	2/02-3/23	F	945A-1145P	BU118
4895	HUM 767 **	FILM CLASSICS	0.0	2/02-5/18	F	100P-400P	WM1
4253	CSIS 124 **	WINDOWS FUNDAMENTAL	1.0	2/05-3/07	M W	900A-1100A	SV002
4879	CMUN 129	PRESENTATN GRAPHICS	1.0	2/05-3/12	M W	1245P-200P	LI120
4633	LIB 730 **	INTERNET LITERACY	0.0	2/06-3/06	Tu Th	930A-1130A	SV002
4877	AH 742 **	COPING WITH LOSS	0.0	2/06-3/27	Tu	100P-300P	COGMR
4876	ENGL 752 **	JOURNAL WRITING OA	0.0	2/06-3/27	Tu	300P-500P	COGMR
4057	AH 740 **	TAI CHI ARTHRITIS	0.0	2/06-4/05	Tu Th	930A-1030A	GHR1
4856	MUS 763 **	MUSIC ENCOUNTERS	0.0	2/06-5/03	Tu Th	200P-300P	GHR1
6056	CSIS 5	C++ SCIENTIFIC PROG	3.0	2/06-5/15	Tu	600P-950P	BU111
6007	AH 32	BASIC CARD/LIFE SUP	1.0	2/10-2/11	SUN	800A-500P	HOB114
6007	AH 32	BASIC CARD/LIFE SUP	1.0	2/10-2/11	SAT	800A-500P	HOB114
4254	CSIS 124	WINDOWS FUNDAMENTAL	1.0	2/12-4/30	M	900A-1110A	BU111
6079	CSIS 126	WORD PROCESS-MS WRD	2.0	2/12-5/14	M	1120A-1245P	BU111
6174	RE 160	REAL ESTATE PRINC	3.0	2/12-5/21	M	630P-940P	SS205
6080	CSIS 126 **	WORD PROCESS-MS WRD	2.0	2/21-5/16	W	600P-910P	SV002
6119	GUID 28	TUTORING TECHNIQUE	1.0	2/23-4/06	SAT	930A-230P	LI116
					F	100P-235P	SS111
6008	AH 32	BASIC CARD/LIFE SUP	1.0	3/03-3/04	SAT/SUN	800A-500P	HOB114
4634	LIB 730 **	INTERNET LITERACY	0.0	3/08-4/05	Tu Th	930A-1130A	SV002
4256	CSIS 126 **	WORD PROCESS-MS WRD	2.0	3/12-5/16	M W	900A-1100A	SV002
6054	CSIS 1	COMPUTER LITERACY	2.0	3/14-5/16	W	600P-950P	BU111
4746	PE 46	AGILITY/MOTOR DEV	0.5	3/19-5/24	MTuWTh	310P-400P	GY131G
6164	PE 61	SWIM FOR FITNESS	0.5	3/20-5/24	Tu Th	515P-640P	GY100P
4718	PE 16	SWIMMING	0.5	3/26-5/23	M W	1255P-220P	GY100P
4720	PE 17	GOLF	0.5	3/26-5/23	M W	1120A-1245P	GY200C
4220	CSIS 1	COMPUTER LITERACY	2.0	3/27-5/22	Tu Th	900A-1105A	BU120
4728	PE 27	BASKETBALL	0.5	3/27-5/24	Tu Th	230P-430P	GY131G
4229	CSIS 10	BASIC PROGRAMMING	2.0	3/30-5/18	F	945A-1145A	BU118
6162	PE 17	GOLF	0.5	3/31-5/19	SAT	900A-1200P	GY200C
4872	AH 740 **	TAI CHI ARTHRITIS	0.0	4/05-6/12	Tu Th	1000A-1100A	WM1
6029	BIO 21	FIELD ECOLOGY	1.0	4/16-4/28	M	630P-830P	LS101
					SAT	800A-600P	LS101
4058	AH 740	TAI CHI ARTHRITIS	0.0	4/17-6/14	Tu Th	930A-1030A	GHR1
6045	CD 28B	DEV LEARNING ACTIVI	1.0	4/27-5/05	F	600P-850P	CD127
					SAT	900A-400P	CD127

\* Noncredit class. See pages 40-43.      \*\* Off campus location. See page 31.

## Class lists by week days (MW, TuTh, M, Tu, W, Th, F)

See pages 36-39.

**save gas!  
save time!  
save energy!**

**Take 12 units of transferable  
General Education classes in  
the morning!**

**AT MORGAN HILL**

<u>SECT</u>	<u>COURSE</u>	<u>DESCRIPTION</u>	<u>UNITS</u>	<u>TIME</u>	<u>ROOM</u>
<b><u>Monday/Wednesday</u></b>					
4158	CD 3	CHILD GROWTH/DEV	3.0	1120A-1245P	MHG4
4159	CD 5	CHILD/FAMILY/COMMUN	3.0	945A-1110A	MHG4
315	ENGL 1B	COMPOSITION & LIT	3.0	810A-935A	MHG10
4357	ENGL 250	PRACTICAL WRITING	3.0	1120A-1245P	MHG11
			Lab: W	1255P-155P	MHG4
4356	ENGL 250	PRACTICAL WRITING	3.0	1120A-1245P	MHG11
			Lab: M	1255P-155P	MHG4
4452	HIST 1	US HISTORY	3.0	810A-935A	MHG4
4457	HIST 2	U.S. HISTORY	3.0	945A-1110A	MHG10
4805	PSYC 3	CHILD GROWTH/DEV	3.0	1120A-1245P	MHG4
<b><u>MTuWTh</u></b>					
4090	ART 6	ART APPRECIATION	3.0	1120A-1245P	MHG4
4188	CMUN 1A	INTRO PUBLIC SPEAK	3.0	945A-1110A	MHG3
4301	ENGL 1A	COMPOSITION	3.0	810A-935A	MHG4
4800	PSYC 1A	INTRO TO PSYCHOLOGY	3.0	1120A-1245P	MHG3
<b><u>Tuesday/Thursday</u></b>					
44652	MATH 205	ELEM ALGEBRA	5.0	945A-1055A	MHG13
4663	MATH 233	INTERMED ALGEBRA	5.0	945A-1055A	MHG11

**Two day  
Counseling Services**

available in Morgan Hill  
Appointment or drop-in

Call (408) 782-2873 to schedule  
an appointment.

**Morgan Hill  
Community and Cultural Center**

17060 Monterey Rd.  
Morgan Hill, CA 95037  
(408) 782-2873

Site Office Hours - See page 5.

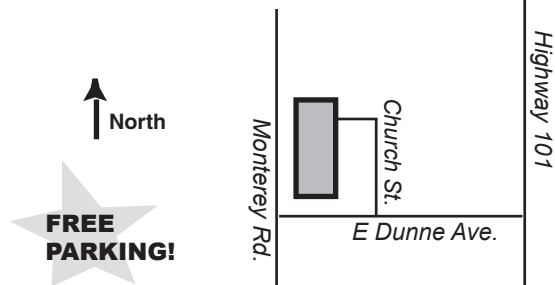

We are pleased to provide the following services for your convenience at the Morgan Hill Community Center satellite site:

- Admissions** Accept applications for admission  
Sell catalogs and distribute class schedules
- Registration and Records** Class registration  
Add/drops  
Assessment test results  
Unofficial grade print-outs  
Dispense forms: Transcript Requests, Repeated Course Requests, Prerequisite Challenge Forms, etc.
- Orientations** (online)
- Placement/Assessment** on site (check website for times and locations)
- CalWORKs** Academic planning
- Counseling** Academic and educational planning

- Financial Aid** Assistance with BOG Fee Waiver forms  
Assistance with financial aid information
- Bookstore** Order textbooks online at efollet.com  
Purchase scantrons and bluebooks
- Library** Provides research assistance via email and phone  
Search e-books and databases, and much more.
- Career/Transfer** College catalog library, EUREKA
- Computer Access**

Services for veterans and international students available at the main campus. All other services, including EOP&S, DRC, CARE, MESA, TRIO and the Tutoring Center available at the Gilroy main campus. Call 408-848-4800. Check catalog or website for complete listings - [www.gavilan.edu](http://www.gavilan.edu)

Gavilan College offers courses that meet in Morgan Hill and Hollister, on the weekend and start late in the semester. See course listings starting on page 58 (spring) and page 122 (summer) and consult a counselor for guidance. Students may register at any of our three sites, online or by telephone.

<u>SECT</u>	<u>COURSE</u>	<u>DESCRIPTION</u>	<u>UNITS</u>	<u>BEGIN-END</u>	<u>DAY</u>	<u>TIMES</u>	<u>ROOM</u>
6006	ACCT 120	COMPUTERIZED ACCTNG	2.0	2/05-5/21	M	630P-940P	MHG5
6001	ACCT 20	FINANCIAL ACCT	4.0	2/01-5/24	Th	550P-950P	MHG5
6010	AJ 18	CMUN/HUMAN RELATION	3.0	2/05-5/21	M	630P-940P	MHG3
6011	AJ 20	JUVENILE LAW/PROCED	3.0	1/31-5/23	W	630P-940P	MHG3
6013	ANTH 1	INTRO PHYSICAL ANTH	3.0	2/06-5/22	Tu	630P-940P	MHG10
6014	ART 1A	ART HISTORY	3.0	1/31-5/23	W	630P-940P	MHG11
4090	ART 6	ART APPRECIATION	3.0	2/01-5/24	Tu Th	1120A-1245P	MHG4
6022	ART 74	ADVANCED PHOTOSHOP	3.0	2/01-5/24	Th	630P-940P	MHG8
6023	ART 75	PHOTOSHOP I	3.0	2/06-5/22	Tu	630P-940P	MHG8
4120	ART 85	WEB DESIGN I: DREAM	2.0	2/06-5/01	Tu	1120A-225P	MHG8
6025	ASTR 1	INTRO GEN ASTRONOMY	3.0	2/06-5/22	Tu	630P-940P	MHG3
6035	CD 1	PRIN/PHIL EC EDUC	3.0	2/05-5/21	M	630P-940P	MHG10
6041	CD 1	PRIN/PHIL EC EDUC	3.0	2/06-5/22	Tu	600P-910P	MHG11
4158	CD 3	CHILD GROWTH/DEV	3.0	1/31-5/23	M W	1120A-1245P	MHG4
4159	CD 5	CHILD/FAMILY/COMMUN	3.0	2/05-5/23	M W	945A-1110A	MHG4
6522	CD 5	CHILD/FAMILY/COMMUN	3.0	2/03-5/19	SAT	900A-300P	MHG11
6039	CD 11C	SUPERVISION OF ADLT	2.0	2/24-3/31	SAT	800A-400P	MHG4
4188	CMUN 1A	INTRO PUBLIC SPEAK	3.0	2/01-5/22	Tu Th	945A-1110A	MHG3
6049	CMUN 10	SMALL GROUP CMUN	3.0	1/31-5/23	W	630P-940P	MHG10
6512	CMUN 129	PRESENTATN GRAPHICS	1.0	1/06-2/03	SAT	830A-1220P	MHG8
4227	CSIS 8	INTRO TO THE INTERNET	1.0	5/03-5/22	TuTh	1120A-1240P	MHG8
6058	CSIS 12	ASSEMBLY LANGUAGE	3.0	2/10-5/19	SAT	900A-1200P	MHG8
6518	CSIS 12L	ASSEMBLY LANG LAB	1.0	2/10-5/19	SAT	1200P-100P	MHG8
6059	CSIS 23	INDEPENDENT STUDY	1.0	2/04-5/20	SUN	400P-800P	MHG8
6061	CSIS 48	UNIX/LINUX OP.SYS	4.0	2/05-5/21	M	600P-950P	MHG8
6062	CSIS 51	VISUAL BASIC .NET	4.0	2/06-5/22	Tu	600P-950P	MHG5
6066	CSIS 74	ADVANCED PHOTOSHOP	3.0	2/01-5/24	Th	630P-940P	MHG8
6067	CSIS 75	PHOTOSHOP I	3.0	2/06-5/22	Tu	630P-940P	MHG8
4238	CSIS 85	WEB DESIGN I: DREAM	2.0	2/06-5/01	Tu	1120A-225P	MHG8
6068	CSIS 120	COMPUTER ACCOUNTING	2.0	2/05-5/21	M	630P-940P	MHG5
4244	CSIS 121	SPREADSHEET-MS EXCL	2.0	2/01-4/26	Th	1120A-225P	MHG8
6071	CSIS 122	COMPUTER KEYBOARD	1.0	2/10-5/19	SAT	830A-1220P	MHG5
6070	CSIS 122	COMPUTER KEYBOARD	0.5	2/10-5/19	SAT	830A-1220P	MHG5
6076	CSIS 124	WINDOWS FUNDAMENTAL	1.0	2/17-3/17	SAT	830A-1220P	MHG5
6078	CSIS 126	WORD PROCESS-MS WRD	2.0	3/24-5/19	SAT	830A-1220P	MHG5
6082	CSIS 128	DATABASE-MS ACCESS	2.0	3/14-5/16	W	600P-955P	MHG8
6511	CSIS 129	PRESENTATN GRAPHICS	1.0	1/06-2/03	SAT	830A-1220P	MHG8
6085	DM 74	ADVANCED PHOTOSHOP	3.0	2/01-5/24	Th	630P-940P	MHG8
6086	DM 75	PHOTOSHOP I	3.0	2/06-5/22	Tu	630P-940P	MHG8
4288	DM 85	WEB DESIGN I: DREAM	2.0	2/06-5/01	Tu	1120A-225P	MHG8
6088	ECON 2	PRIN MICROECONOMICS	3.0	2/03-5/19	SAT	900A-1205P	MHG3
4301	ENGL 1A	COMPOSITION	3.0	2/01-5/24	Tu Th	810A-935A	MHG4
6094	ENGL 1A	COMPOSITION	3.0	2/01-5/24	Th	630P-940P	MHG3
4315	ENGL 1B	COMPOSITION & LIT	3.0	1/31-5/23	M W	810A-935A	MHG10
4357	ENGL 250	PRACTICAL WRITING	3.0	1/31-5/23	M W	1120A-1245P	MHG11
					W	1255P-155P	MHG4
4356	ENGL 250	PRACTICAL WRITING	3.0	1/31-5/23	M W	1120A-1245P	MHG11
					M	1255P-155P	MHG4
6106	ESL 501A	SURVIVAL ESL I A	3.0	1/31-5/24	M WTh	600P-735P	MHG12
6520	GBUS 14	PERSONAL FINANCE	3.0	2/03-5/19	SAT	800A-1105A	MHG12
4452	HIST 1	US HISTORY	3.0	1/31-5/23	M W	810A-935A	MHG4
4457	HIST 2	U.S. HISTORY	3.0	1/31-5/23	M W	945A-1110A	MHG10
6134	MATH 5	INTRO STATISTICS	3.0	1/31-5/23	M W	630P-835P	MHG4
4652	MATH 205	ELEM ALGEBRA	5.0	1/31-5/24	MTuWTh	945A-1055A	MHG13
6138	MATH 205	ELEM ALGEBRA	5.0	2/06-5/22	Tu Th	630P-900P	MHG13
4663	MATH 233	INTERMED ALGEBRA	5.0	1/31-5/24	MTuWTh	945A-1055A	MHG11
6165	PE 62	YOGA	1.0	1/31-5/23	M W	500P-625P	MHG10
4800	PSYC 1A	INTRO TO PSYCHOLOGY	3.0	2/01-5/24	Tu Th	1120A-1245P	MHG3
6172	PSYC 1A	INTRO TO PSYCHOLOGY	3.0	2/01-5/24	Th	600P-910P	MHG10
4805	PSYC 3	CHILD GROWTH/DEV	3.0	1/31-5/23	M W	1120A-1245P	MHG4
6179	SPAN 8A	CONVER SPANISH	3.0	2/05-5/21	M	630P-940P	MHG11

For Noncredit classes in Morgan Hill, see page 41-43.

One day per month

**Counseling Services**

available at the Hollister site.

Call (831) 636-3783 to schedule an appointment.

**save gas!  
save time!  
save energy!**

**Take 12 units of transferable General Education at Hollister in the morning!**

**Hollister Briggs Building (San Benito County)**

Briggs Building  
365 Fourth St.  
Hollister, CA 95023  
(831) 636-3783

Site Office Hours: See page 5

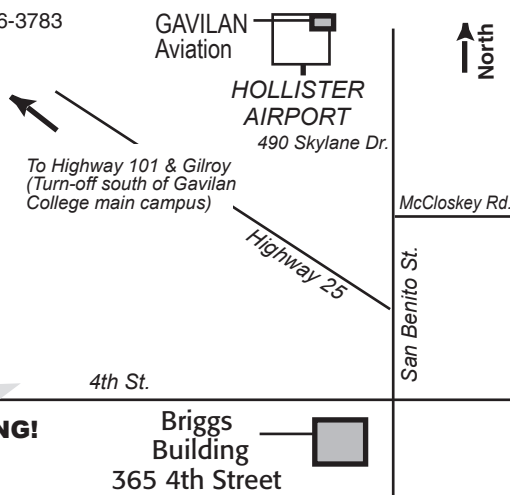

**Monday/Wednesday**

4187	CMUN 1A	INTRO PUBLIC SPEAK	3.0	810A-935A	HOL1
4199	CMUN 10	SMALL GROUP CMUN	3.0	945A-1110A	HOL1
4350	ENGL 250	PRACTICAL WRITING	3.0	945A-1110A	HOL4
				Lab: M 1115A-1215P	HOL4
4351	ENGL 250	PRACTICAL WRITING	3.0	945A-1110A	HOL4
				Lab: W 1115A-1215P	HOL4
4815	SOC 1A	INTRO TO SOCIOLOGY	3.0	1120A-1245P	HOL1

**Tuesday/Thursday**

4306	ENGL 1A	COMPOSITION	3.0	945A-1110A	HOL4
4324	ENGL 1C	CRITIC REASON/WRITE	3.0	945A-1110A	HOL5
4786	POLS 1	INTRO AMERICAN GOVERNMENT	3.0	945A-1110A	HOL1
4799	PSYC 1A	INTRO TO PSYCHOLOGY	3.0	1120A-1245P	HOL1

**Mon/Tues/Wed/Thurs**

4823	SPAN 1A	ELEMENTARY SPANISH	5.0	830A-940A	HOL2
4825	SPAN 1B	ELEMENTARY SPANISH	5.0	1000A-1110A	HOL6
4654	MATH 205	ELEM ALGEBRA	5.0	1120A-1230P	HOL6
4665	MATH 233	INTERMED ALGEBRA	5.0	1120A-1230P	HOL2

We are pleased to provide the following services for your convenience at the Hollister Briggs Building satellite site:

- Admissions** Accept applications for admission  
Sell catalogs and distribute class schedules
- Registration and Records** Class registration  
Add/drops  
Assessment test results  
Unofficial grade print-outs  
Dispense forms: Transcript Requests, Repeated Course Requests, Prerequisite Challenge Forms, etc.
- Orientations** (online)
- Placement Assessment** on site (check website for times and locations)
- Counseling** Academic and educational planning (One day per month, by appointment)
- Financial Aid** Assistance with BOG Fee Waiver forms  
Assistance with financial aid information
- Bookstore** Order textbooks online at efollet.com  
Purchase scantrons and bluebooks
- Library** Provides research assistance via email and phone  
Search e-books and databases, and much more.
- Career/Transfer** College catalog library, EUREKA
- Computer Access**

Services for veterans and international students available at the main campus. All other services, including EOP&S, DRC, CalWORKs, CARE, MESA, TRIO and the Tutoring Center available at the Gilroy main campus. Call 408-848-4800. Check catalog or website for complete listings - [www.gavilan.edu](http://www.gavilan.edu)

## Spring 2007 Schedule

Gavilan College offers courses that meet in Morgan Hill and Hollister, on the weekend and start late in the semester. See course listings starting on page 58 (spring) and page 122 (summer) and consult a counselor for guidance. Students may register at any of our three sites, online or by telephone.

<u>SECT</u>	<u>COURSE</u>	<u>DESCRIPTION</u>	<u>UNITS</u>	<u>BEGIN-END</u>	<u>DAY</u>	<u>TIMES</u>	<u>ROOM</u>	
6004	ACCT 103	GEN OFFICE ACCT	2.0	1/31-5/23	W	600P-910P	HOL1	
6502	ACCT 120	COMPUTERIZED ACCTNG	2.0	2/09-5/18	F	530P-840P	HOL3	
*/**	4056	AH 740	0.0	2/01-6/07	Th	1100A-1200P	HOLCC	
***	4072	AMT 101	7.5	1/18-5/25	DAILY	800A-1030A	AV102	
***	4073	AMT 111	13.5	1/18-5/25	DAILY	1030A-330P	AV102	
***	4074	AMT 121	14.0	1/18-5/25	TuWThF	830A-300P	AV102	
4880	ART 1B	ART HISTORY	3.0	1/31-5/23	M W	1255P-220P	HOL4	
6020	ART 25A	ART METHODS	3.0	2/02-5/25	F	400P-815P	HOL1	
6021	ART 25B	CONCEPT ART METHODS	3.0	2/02-5/25	F	400P-815P	HOL 1	
6036	CD 3	CHILD GROWTH/DEV	3.0	2/05-5/21	M	600P-910P	HOL2	
6038	CD 9	CHLD HLTH/NUTR/SAFE	3.0	2/06-5/22	Tu	600P-910P	HOL5	
6042	CD 13	INFANT/TODDLER CARE	3.0	2/01-5/24	Th	600P-910P	HOL5	
6521	CD 25A	ART METHODS	3.0	2/02-5/25	F	400P-815P	HOL1	
6044	CD 25B	CONCEPT ART METHODS	3.0	2/02-5/25	F	400P-815P	HOL 1	
4187	CMUN 1A	INTRO PUBLIC SPEAK	3.0	1/31-5/23	M W	810A-935A	HOL1	
4199	CMUN 10	SMALL GROUP CMUN	3.0	1/31-5/23	M W	945A-1110A	HOL1	
6050	CMUN 10	SMALL GROUP CMUN	3.0	1/31-5/25	Th	600P-910P	HOL1	
4202	CMUN 129	PRESENTATN GRAPHICS	1.0	4/18-5/16	M W	900A-1105A	HOL3	
6053	CSIS 1	COMPUTER LITERACY	2.0	2/06-4/03	Tu	600P-950P	HOL3	
4218	CSIS 1	COMPUTER LITERACY	2.0	2/05-4/04	M W	900A-1105A	HOL3	
6515	CSIS 120	COMPUTER ACCOUNTING	2.0	2/02-5/25	F	530P-840P	HOL3	
6069	CSIS 121	SPREADSHEET-MS EXCL	2.0	3/21-5/09	W	555P-955P	HOL3	
4252	CSIS 122	COMPUTER KEYBOARD	1.0	1/31-5/23	M W	1120A-125P	HOL3	
6073	CSIS 122	COMPUTER KEYBOARD	0.5	2/05-5/21	M	600P-850P	HOL3	
6072	CSIS 122	COMPUTER KEYBOARD	1.0	2/05-5/21	M	600P-850P	HOL3	
4251	CSIS 122	COMPUTER KEYBOARD	0.5	2/05-5/14	M W	1120A-125P	HOL3	
4250	CSIS 122	COMPUTER KEYBOARD	1.0	1/31-5/23	M W	900A-1105A	HOL3	
4249	CSIS 122	COMPUTER KEYBOARD	0.5	2/05-5/23	M W	900A-1105A	HOL3	
4255	CSIS 124	WINDOWS FUNDAMENTAL	1.0	2/05-3/07	M W	1120A-125P	HOL3	
6077	CSIS 124	WINDOWS FUNDAMENTAL	1.0	2/08-3/08	Th	600P-950P	HOL3	
6517	CSIS 126	WORD PROCESS-MS WRD	2.0	3/15-5/17	Th	600P-950P	HOL3	
4258	CSIS 129	PRESENTATN GRAPHICS	1.0	4/18-5/16	M W	900A-1105A	HOL3	
4306	ENGL 1A	COMPOSITION	3.0	2/01-5/22	Tu Th	945A-1110A	HOL4	
6093	ENGL 1A	COMPOSITION	3.0	2/06-5/22	Tu	630P-940P	HOL6	
4324	ENGL 1C	CRITIC REASON/WRITE	3.0	2/01-5/22	Tu Th	945A-1110A	HOL5	
4350	ENGL 250	PRACTICAL WRITING	3.0	1/31-5/23	M W	945A-1110A	HOL4	
4351	ENGL 250	PRACTICAL WRITING	3.0	1/31-5/23	M W	945A-1110A	HOL4	
					W	1115A-1215P	HOL4	
					Th	530P-940P	HOL6	
6101	ENGL 250	PRACTICAL WRITING	3.0	2/01-5/24	Th	530P-940P	HOL6	
6108	ESL 501A	SURVIVAL ESL I A	3.0	1/31-5/25	M W F	600P-735P	HOL6	
6110	ESL 501B	SURVIVAL ESL I B	3.0	1/31-5/25	M W F	745P-920P	HOL6	
6112	ESL 502B	SURVIVAL ESL II B	3.0	1/31-5/25	M W F	600P-735P	HOL4	
6114	ESL 503A	SURVIVAL ESL III A	3.0	1/31-5/25	M W F	745P-920P	HOL4	
4415	GBUS 1	FUND OF BUSINESS	3.0	1/31-5/23	M W	1240P-200P	HOL5	
4905	GEOG 1	PHYSICAL GEOGRAPHY	3.0	1/31-5/23	M W	945A-1215P	HOL5	
6120	HIST 2	U.S. HISTORY	3.0	1/31-5/23	W	630P-940P	HOL2	
*	4638	LIB 730	INTERNET LITERACY	0.0	3/26-5/09	M W	130P-300P	HOL3
*	4637	LIB 730	INTERNET LITERACY	0.0	2/05-3/19	M W	130P-300P	HOL3
4654	MATH 205	ELEM ALGEBRA	5.0	1/31-5/24	MTuWTh	1120A-1230P	HOL6	
6140	MATH 233	INTERMED ALGEBRA	5.0	2/01-5/22	Tu Th	600P-830P	HOL4	
4665	MATH 233	INTERMED ALGEBRA	5.0	1/31-5/24	MTuWTh	1120A-1230P	HOL2	
4698	MUS 9A	GUITAR	1.0	2/05-5/21	M	100P-405P	HOL2	
**	6167	PE 62	YOGA	1.0	2/01-5/24	Tu Th	500P-625P	VET218
*/**	4774	PE 716	MUSIC MOVE & HEALTH	0.0	2/06-6/12	Tu	1000A-1200P	HOLCC
6168	PHIL 2	LOGIC	3.0	1/31-5/23	W	600P-910P	HOL5	
4786	POLS 1	INTRO AMERICAN GOVERNMENT	3.0	2/01-5/24	Tu Th	945A-1110A	HOL1	
6170	PSCI 1	PRIN PHYS SCIENCE	3.0	2/06-5/22	Tu	630P-940P	HOL1	
4799	PSYC 1A	INTRO TO PSYCHOLOGY	3.0	2/01-5/24	Tu Th	1120A-1245P	HOL1	
6173	PSYC 3	CHILD GROWTH/DEV	3.0	2/05-5/21	M	600P-910P	HOL2	
4815	SOC 1A	INTRO TO SOCIOLOGY	3.0	1/31-5/23	M W	1120A-1245P	HOL1	
6176	SOC 4	SOC OF WOMEN & MEN	3.0	2/05-5/21	M	630P-940P	HOL5	
4823	SPAN 1A	ELEMENTARY SPANISH	5.0	1/31-5/24	MTuWTh	830A-940A	HOL2	
4825	SPAN 1B	ELEMENTARY SPANISH	5.0	1/31-5/24	MTuWTh	1000A-1110A	HOL6	
6178	SPAN 8A	CONVER SPANISH	3.0	2/05-5/21	M	600P-910P	HOL1	

\* Noncredit class

\*\* Class meets at an off-campus location. List on page 31.

\*\*\* Meets at Gavilan College Aviation Department, 490 Skylane Drive, Hollister Airport, Hollister. Aviation classes begin January 18, 2007.

# WINTER

# Interession 2007

January 3 - 26, 2007

## CALENDAR

### Interession Begins

Students must be registered before the start of the course.

**Wed, Jan 3**

### Refund Deadline

Fees, minus a \$10. processing fee will be refunded when term-long courses are officially dropped. Refunds are not "automatic" even when a course is cancelled. Students must complete the drop prior to 10:00 pm on January 4 and file a Request for Refund form with the Admissions and Records Office no later than 5:00 pm on Tuesday, January 9.

**Thurs, Jan 4  
at 10:00 PM**

### "NRS" Deadline

Courses dropped by this date do not appear on the student's permanent record (No Record Shown).

**Tues, Jan 9  
at 10:00 PM**

### Deadline for Grading Option

Last day to elect the Cr/NC grading option for designated courses.

**Tues, Jan 9  
at 10:00 PM**

### Martin Luther King Holiday

Campus closed

**Mon, Jan 15**

### "W" Deadline

Term-long courses dropped by this date appear on the student's record with a notation of "W" (Withdrawn)

**Fri, Jan 19  
at 10:00 PM**

### Final Exams

last scheduled day of course

### Last Day of Classes

**Fri, Jan 26**

### Final Grades Available

Official transcripts will not be available until the end of Spring 2007. Grade reports are available online at OLGA ([www.gavilan.edu](http://www.gavilan.edu)) or by phone at GavNOW (408-846-3729)

**Mon, Feb 5**

### CONTINUING STUDENTS

Registration open to all students who were enrolled for the fall 2006 semester except high school students.

Dec 4 - Jan 3: Register in person, online or by phone.

### NEW, CONTINUING OR RETURNING STUDENTS

Dec 11 - Jan 3: Register in person, online or by phone.

### HIGH SCHOOL CONTRACT STUDENTS

Dec 11 - Jan 3: Register in person. A counseling appointment is required.

## REGISTER in Person

### MAIN CAMPUS

- Dec 4 - 15: Mon - Thurs, 8 am - 4:30 pm, Fri, 9 am - 4:30 pm
- Dec 18 - 22: Mon - Thurs, 8 am - 6:00 pm, Fri, 9 am - 4:30 pm
- Dec 23 - Jan. 2: Closed for Christmas Holiday
- Jan 3: Tues, 8 am - 4:30 pm

### MORGAN HILL & HOLLISTER SITES

- Dec 4 - 22: Mon - Thurs, 8 am - 2 pm, 6 - 8 pm  
Fri, 8 am - 12 pm, 1 - 5 pm

The Morgan Hill and Hollister sites will be closed 12/23 - 1/6/07.

## REGISTER by...

**Phone** Call GavNOW at (408) 846-3729

**Online** Go to [www.gavilan.edu](http://www.gavilan.edu) and click on OLGA

- Dec 4 - Jan 3: Mon - Fri, 9 am - 10 pm



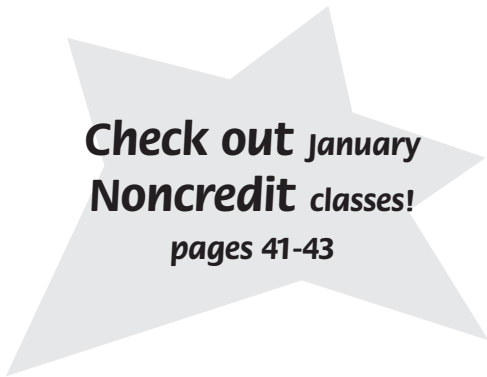

# Classes

## ALLIED HEALTH

### AH 32 Basic Cardiac Life Support

Transferable: CSU

Course designed to teach students skills in adult, child and infant cardiopulmonary resuscitation. Specifically designed for health professionals. Successful completion will result in certification by the American Heart Association or American Red Cross. This is a credit/no credit course. May be repeated up to three times for credit.

4040	LEC	HOB114	LOGAN C	18.00	1.0	WTh	0800A-0500P	11 32
01/24/07 - 01/25/07								

## ART

### ART 98 Special Topics - Teapot Workshop

Transferable: CSU; GAV-GE: C1

This course offers an opportunity to focus on a complex, sculptural form steeped in cultural traditions. The history, function and types of teapots will be discussed and demonstrated, with the development of a personal, contemporary statement by each student as a desired outcome. This class is appropriate for beginners or experienced students and has no prerequisites. For transfer status, check with a counselor. This course may have the option of a letter grade or credit/no credit.

6024	LEC	AR101	REKEDAL J	6.00	1.0	TuTh	0600P-0850P	
01/09/07 - 01/25/07								

**Footnotes contain valuable information pertaining to your class selection. Footnotes follow spring class listings.**

Sect. Type Room Instructor Hrs. Units Days Begin-End Footnotes

## BUSINESS OFFICE TECHNOLOGY

### BOT 191B Workplace Skills

Transferable: CSU

Workplace Skills teaches skills vital to workplace success. The topic for 191B is Team Building. Need not be taken in sequence. This is a credit/no credit course.

4156	LEC	L1100	GARCIA C	8.00	1.0	DAILY	0930A-1145A	25 88
01/09/07 - 01/16/07								

## COMMUNICATIONS

### CMUN 129 Presentation Graphics - MS PowerPoint

Advisory: CSIS 126 or word processing skills in the Windows environment.

Transferable: CSU

This introductory course in presentation graphics will use Microsoft Office's "PowerPoint" software to create a computerized presentation (slide show) with text and objects. This course is also listed as CSIS 129. This course has the option of a letter grade or credit/no credit. May be repeated three times for credit.

6512	LEC	MHG8	HAMPTON	4.0	1.0	S	0830A-1220P	11 25
01/06/07-02/03/07 Above class meets at the Morgan Hill Community site								

## COUNSELORS

**AVAILABLE FOR REGISTRATION ASSISTANCE ONLY DURING WINTER INTERSESSION GILROY, HOLLISTER, MORGAN HILL**

Gavilan Main Campus (walk in):

Jan 3-4 & 8-11	8:00 am - 3:30 pm
Jan 16-19	8:00 am - 3:30 pm
<i>Counseling will be closed on Jan 5, 12 and 15</i>	
Jan 22-26	8:00 am - 3:30 pm
Jan 29	8:00 am - 3:30 pm, 4:00-6:30 (appts. ONLY after 4:00 pm)

Morgan Hill and Hollister sites (by appointment or drop-in):

Jan 9	Tu	11:00 am - 7:00 pm
Jan 10	W	11:00 am - 7:00 pm
Jan 23	Tu	11:00 am - 7:00 pm
Jan 24	W	11:00 am - 7:00 pm

Call 408-782-2873 for an appointment in Morgan Hill.  
Call 831-636-3783 for an appointment in Hollister.



Sect. Type Room Instructor Hrs. Units Days Begin-End Footnotes

Sect. Type Room Instructor Hrs. Units Days Begin-End Footnotes

## COMPUTER SCIENCE & INFORMATION SYSTEMS

### CSIS 3 Internet and Information Competency

**Advisory:** Eligible for English 250 and 260.  
**Transferable:** CSU

Research and evaluation skills using the Internet and other electronic resources, as well as traditional printed materials. This course is also listed as LIB 3. This course has the option of a letter grade or credit/no credit. May be repeated once for credit.

4892 LEC ONLINE YOUNG D 4.60 2.0 DHR 0000-0000 11 25 38  
01/03/07-02/23/07 This online class will be delivered entirely over the internet. After enrolling, start the class by going to <http://www.gavilan.edu/disted/>, click on your class link, and email the instructor at [dyoung@gavilan.edu](mailto:dyoung@gavilan.edu). Students who have not begun the class or contacted the instructor by 5 pm on the 3rd day of class will be dropped from the class.



### CSIS 10 BASIC Programming

**Advisory:** CSIS 1 or CSIS 2 or equivalent experience.  
**Transferable:** CSU; UC

This course is an introduction to programming using BASIC. No previous programming background is assumed. This is a good class for those new to programming and recommended for non-programmers that want to take other programming classes. This course has the option of a letter grade or credit/no credit.

This class starts early. Check dates.

4881 DHR ONLINE VANTASSELD 4.6 2.0 DHR 0000-0000 11 38  
12/18/07-01/31/07 This online class will be delivered entirely over the internet. After enrolling, start the class by going to <http://www.gavilan.edu/disted/>, click on your class link, and email the instructor at [dvantassel@gavilan.edu](mailto:dvantassel@gavilan.edu). Students who have not begun the class or contacted the instructor by 5 pm on the 3rd day of class will be dropped from the class.



### CSIS 84 JavaScript Programming

**Advisory:** CSIS 6  
**Transferable:** CSU; UC

Fundamentals of JavaScript client-side programming for Web pages requiring data collection or other user interaction. Students will create Web pages that execute on the client (personal system) using JavaScript. This course may be repeated one time for credit. This course has the option of a letter grade or credit/no credit.

This class starts early. Check dates.

4882 DHR ONLINE VANTASSELD 4.6 2.0 DHR 0000-0000 11 38  
12/18/07-01/31/07 This online class will be delivered entirely over the internet. After enrolling, start the class by going to <http://www.gavilan.edu/disted/>, click on your class link, and email the instructor at [dvantassel@gavilan.edu](mailto:dvantassel@gavilan.edu). Students who have not begun the class or contacted the instructor by 5 pm on the 3rd day of class will be dropped from the class.



### CSIS 121 Spreadsheet - MS Excel

**Advisory:** CSIS 1 or CSIS 2 or equivalent computer experience.  
**Transferable:** CSU

Introduction to the computer spreadsheet software. A hands-on approach to learning terms, commands, and applications of a spreadsheet program. This course will help prepare students for taking the Excel MOUS (Microsoft Office User Specialist) exams. This course has the option of a letter grade or credit/no credit and may be repeated for credit when the software changes.

6516 LEC BU111 THOMPSON F 4.6 2.0 TWTh 0600P-0950P 11  
01/09/07-01/25/07

### CSIS 129 Presentation Graphics - MS PowerPoint

**Advisory:** CSIS 126 or word processing skills in the Windows environment.  
**Transferable:** CSU

This introductory course in presentation graphics will use Microsoft Office's "PowerPoint" software to create a computerized presentation (slide show) with text and objects. This course is also listed as CMUN 129. This course has the option of a letter grade or credit/no credit. May be repeated three times for credit.

6511 LEC MHG8 HAMPTON 4.0 1.0 S 0830A-1220P 11 25  
01/06/07-02/03/07 Above class meets at the Morgan Hill Community site

## GEOGRAPHY

### GEOG 1 Physical Geography

**Advisory:** Eligible for English 250 and English 260.  
**Transferable:** CSU; UC; CSU-GE: B1, B3; IGETC: 5A; GAV-GE: B1, B3; CAN: GEOG 2

An introductory study of the basic physical elements of geography including climate, land forms, soils, water, and natural vegetation. The laboratory will include the tools and methods of geographers.

4417 L/L CH102 WILLAHAN D 30.0 3.0 DAILY 0900A-0200P 1  
01/03/07-01/26/07

## GUIDANCE

### GUID 191B Workplace Skills

**Transferable:** CSU

Workplace Skills teaches skills vital to workplace success. The topic for 191B is team building. Need not be taken in sequence. This is a credit/no credit course.

4430 LEC LI100 GARCIA C 8.00 1.0 DAILY 0930A-1145A 25 88  
01/09/07-01/16/07

## LIBRARY

### LIB 3 Internet and Information Competency

**Advisory:** Eligible for English 250 and 260.  
**Transferable:** CSU

Research and evaluation skills using the Internet and other electronic resources, as well as traditional printed materials. This course is also listed as CSIS 3. This course has the option of a letter grade or credit/no credit. May be repeated once for credit.

4893 LEC ONLINE YOUNG D 4.60 2.0 DHR 0000-0000 11 25 38  
01/03/07-02/23/07 This online class will be delivered entirely over the internet. After enrolling, start the class by going to <http://www.gavilan.edu/disted/>, click on your class link, and email the instructor at [dyoung@gavilan.edu](mailto:dyoung@gavilan.edu). Students who have not begun the class or contacted the instructor by 5 pm on the 3rd day of class will be dropped from the class.



## PHYSICAL EDUCATION: ACTIVITIES

### PE 37 Softball

**Transferable:** CSU; UC; CSU-GE: E1; GAV-GE: E1

Coeducational activity designed for all skill levels. Rules, fundamentals, and strategy and game play will be included. May be repeated three times for credit. This course has the option of a letter grade or credit/no credit.

4739 LAB GY131G THOMPSON N 13.60 1.0 DAILY 0130P-0500P 11  
01/03/07-01/26/07

Sect. Type Room Instructor Hrs. Units Days Begin-End Footnotes

**PE 65 Baseball**

Transferable: CSU; UC; CSU-GE: E1; GAV-GE: E1

Course designed for students who desire to learn the fundamentals, mechanics, strategy, history and rules of the game of competitive baseball. Course is designed for students of all skill levels, ages, and both genders who wish to play or coach youth baseball. This course has the option of a letter grade or credit/no credit. May be repeated three times for credit.

4750 LAB GY131G ANDRADE N 13.60 1.0 DAILY 0100P-0430P 11  
01/03/07 - 01/26/07

**PHYSICAL EDUCATION: ADAPTED**

**PE 534 Adapted Aquatic Exercise**

Transferable: No

Designed to help individuals who by the nature of their disability such as wheelchair use, back injury, cardiovascular impairment, multiple sclerosis or other disabling condition require a specific aquatic exercise program that will contribute to their physical well being. May be repeated as necessary based on measurable progress as documented in the student's educational contract. This is a credit/no credit course.

4754 LAB GY100P ELLIS D 1.70 .5 MTuWTh 1115A-1250P 31 75  
01/03/07 - 01/25/07

**PE 536 Adapted Physical Education**

Transferable: No

An individualized program of adaptive physical education activities designed to meet the needs of students with physical disabilities. Develops an appreciation of physical activity as a regular planned contribution to one's overall well-being. May be repeated as necessary based on measurable progress as documented in the student's educational contract. This is a credit/no credit course.

4760 LAB APE108 ELLIS D 1.70 .5 MTuWTh 0935A-1105A 31 75  
01/03/07 - 01/25/07

**VOCATIONAL PREPARATION FOR DISABLED**

**AE 602 Vocational Training III**

Transferable: No

Practical training and on-the-job work experience for students with disabilities. This course also provides preparation for entry level employment utilizing a number of work alternatives and settings.

4021 LAB HOPE-G LOPEZ F 33.80 .0 DHR 0000-0000 31 63 75  
01/03/07 - 01/29/07 See Footnote: Above class meets Off Campus  
4022 LAB HOPE-H LOPEZ F 33.80 .0 DHR 0000-0000 31 51 75  
01/03/07 - 01/29/07 See Footnote: Above class meets Off Campus

**Classroom Locations: Refer to "How to Use This Schedule" on page 31.**

**Footnotes contain valuable information pertaining to your class selection. Footnotes follow spring class listings.**

**Faculty! Staff! Students!  
Working Parents! Community!**



**Gavilan College has the only accredited child care facility in Gilroy!**

NAEYC #430703716 & #434400444

**FEE-BASED SERVICE**

**6 wks - 5 yrs  
6:30 am - 6:00 pm**

**HALF-DAY PROGRAM** Parents do not have to be students!

Call the Child Development Center at 408-848-4815 for more information.

Gavilan's Child Development Center will accept payment from other subsidized programs (i.e., 4C's, Choices for Children) Personal payment also accepted.

***This class ends in February. See dates.***



**This class meets online**

**Become an Expert Researcher!**

Register for **LIB 3**  
**Internet & Information Competency**

Also listed as CSIS 3.

# SPRING 2007 CLASSES

**For listings of:**

Courses with additional fees . . . . . page 6  
 First Year Experience . . . . . page 87  
 Friday Only courses . . . . . page 39  
 Hollister classes . . . . . pages 52-53  
 Indiana University . . . . . page 18  
 Late Afternoon/Evening courses . . . . . page 48  
 Late-Start/Short-term courses . . . . . page 49  
 Morgan Hill classes . . . . . pages 50-51  
 Noncredit classes . . . . . pages 41-43  
 Online courses . . . . . page 46  
 Telecourses (Gavilan) . . . . . page 47  
 Telecourses (San Jose State University) . . . . . page 47  
 Transfer Institute . . . . . pages 126-127  
 Weekend courses . . . . . page 48  
 Final Exams . . . . . page 121



## Spring Classes

BIOT 104	Seminar in Biotechnology
GBUS 14	Personal Finance
CSIS 12	Assesmbly Language Programming
DM 111	Sound Design for Digital Media
ECON 14	Personal Finance
ENGL 2J	Mythology
ESL 565	Editing for ESL Writers
HIST 4A	History of World Societies, Before 1500
JPN 23	Independent Study
PE 73	Fitness Through Dance
RE 167	Real Estate Economics
SSCI 270B	Introduction to the Social Sciences

Sect. Type Room Instructor Hrs. Units Days Begin-End Footnotes

### ACCOUNTING

**ACCT 20 Financial Accounting**

**Advisory:** Eligible for English 250, English 260 and Mathematics 233. Microsoft Excel or other computer spreadsheet knowledge.  
**Transferable:** CSU; UC; CAN: BUS 2, BUS SEQ. A

An introduction to accounting principles and concepts. The course includes the application of accounting theory to accumulate and summarize financial data. This course has the option of a letter grade or credit/no credit.

4902	LEC	BU118	WOLOWITZ J	4.50	4.0	MW	0900A-1105P
4001	LEC	BU118	WOLOWITZ J	4.50	4.0	TuTh	1255P-0300P
6001	LEC	MHG5	BROWN B	4.50	4.0	Th	0550P-0950P

Above class meets at Morgan Hill Community site

**ACCT 21 Managerial Accounting**

**Advisory:** Accounting 20. Microsoft Excel or other computer spreadsheet knowledge.  
**Transferable:** CSU; UC; CAN: BUS 4, BUS SEQ. A

This course covers the internal uses of accounting information for managerial decision making. Includes coverage of managerial control, cost-volume-profit relationships, budgeting, cost accounting, and other related topics. This course has the option of a letter grade or credit/no credit.

4002	LEC	BU118	WOLOWITZ J	4.50	4.0	MW	1255P-0300P
6003	LEC	BU120	WOLOWITZ J	4.50	4.0	Tu	0545P-0950P

**ACCT 23 Independent Study**

**Required:** The study outline prepared by the student and the instructor must be filed with the department and the dean.  
**Transferable:** CSU

Designed to afford selected students specialized opportunities for exploring areas at the independent study level. The courses may involve extensive library work, research in the community, or special projects. May be repeated until six units of credit are accrued. This course has the option of a letter grade or credit/no credit.

4003	IND	BU129	WOLOWITZ J	3.40	1.0	DHR	0000-0000
------	-----	-------	------------	------	-----	-----	-----------

**ACCT 103 General Office Accounting**

**Advisory:** Eligible for Mathematics 205.  
**Transferable:** CSU

This course is designed to prepare students for entry-level office accounting positions. Emphasis is on practical accounting applications. This course has the option of a letter grade or credit/no credit.

4867	L/L	BU120	COLLEGE A	3.40	2.0	F	0900A-1210P 96
6004	L/L	HOL1	WILKINSON S	3.40	2.0	W	0600P-0910P

Above class meets at the Hollister Briggs site

Sect. Type Room Instructor Hrs. Units Days Begin-End Footnotes

Sect. Type Room Instructor Hrs. Units Days Begin-End Footnotes

**ACCT 111 Introduction to Income Tax**

**Advisory:** Eligible for English 250, English 260 and Mathematics 205.  
**Transferable:** CSU

A study of theory, philosophy, and principles of income tax law and procedures for computing the tax liability. It includes practice in solving typical individual tax problems. This course has the option of a letter grade or credit/no credit.

4004 LEC BU120 BARTAM 3.40 3.0 MW 0810A-0935A 96

**ACCT 120 Computerized Accounting - QuickBooks**

**Advisory:** CSIS 1 or CSIS 2 or the equivalent computer experience. ACCT 20 or ACCT 101 or ACCT 103 or ACCT 105 or the equivalent accounting experience.  
**Transferable:** CSU

An introduction to computer-assisted accounting. Hands-on use of a microcomputer menu-driven accounting package to do general ledger, sales journal, cash receipts journal, cash payments journal, purchases journal, payroll, receivables, payables and related financial reports. This course has the option of a letter grade or credit/no credit. Repeatable whenever a new software package is adopted. This course is also listed as CSIS 120.

4005 L/L BU111 BARTAM 4.40 2.0 W&1.4 0945A-1240P 25 35 96

6006 L/L MHG5 BARTAM 4.40 2.0 M&1.4 0630P-0940P 25 35  
Above class meets at Morgan Hill Community site

6502 L/L HOL 3 HARLOW T 4.40 2.0 F&1.4 0530P-0840P 25 35  
Above class meets at Hollister Briggs site

**ACCT 190 Occupational Work Experience/Accounting**

**Required:** Declared vocational major. Concurrent enrollment in seven or more units (including CWE units, except for summer school. For summer school, enrollment in one other class is required). Minimum 2.00 G.P.A.  
**Transferable:** CSU

College credit for learning experience obtained on the job in accordance with a training plan developed cooperatively between the employer, college and student. 75 hours per semester per unit or 60 hours per semester for unpaid experience. This is a credit/no credit course. May be taken for a maximum of 16 work experience units.

4006 WEX BU125 KERR L 5.60 1.0 DHR 0000-0000 16

4007 WEX BU125 KERR L 11.30 2.0 DHR 0000-0000 16

4008 WEX BU125 KERR L 16.90 3.0 DHR 0000-0000 16

4009 WEX BU125 KERR L 22.50 4.0 DHR 0000-0000 16

**Acting: see Theatre Arts**

**ADMINISTRATION OF JUSTICE**

**AJ 6 Introduction to Conflict Resolution**

**Advisory:** English 250 and English 260.  
**Transferable:** CSU; CSU-GE: D7; GAV-GE: D2

Introduction to Conflict Resolution introduces students to conflict resolution and mediation. Integrating theory and practice, students will assess core concepts about the causes and resolution of conflict, and will practice communication skills for conflict resolution. Students will examine how ethnicity, gender, and class affect power in conflict situations. They will be able to formulate appropriate conflict resolution strategies, and will develop and practice various basic co-mediation skills. This course has the option of a letter grade or credit/no credit. This course is also listed as POLS 6 and PSYC 6 and CMUN 6.

4059 LEC SS205 HALPER L 3.40 3.0 MW 0945A-1110A 25

**AJ 10 Introduction to the Administration of Justice**

**Advisory:** Eligible for English 250 and English 260.  
**Transferable:** CSU; UC; CAN: AJ 2

The history and philosophy of justice as it evolved throughout the world; in-depth study of the American system and various sub-systems; roles and role expectations of criminal justice agents in their interrelationships in society; concepts of crime causations, punishments and rehabilitation; ethics, education and training for professionalism in the social system.

4060 LEC BU118 SMITH S 3.40 3.0 MW 1120A-1250P

4061 LEC BU118 SMITH S 3.40 3.0 TuTh 1120A-1250P

4062 LEC S.BRAT STAFF 3.40 3.0 Tu 0330P-0630P 6

This class is part of the High Step program. It will be offered at Sobrato High School. Check online footnote for location. This class is open to all students. For more information, see a Gavilan counselor.

**AJ 12 Criminal Procedures**

**Advisory:** Eligible for English 250 and English 260.  
**Transferable:** CSU

Legal processes from pre-arrest, arrest through trial, sentencing and correctional procedures; a review of the history of case and common law; conceptual interpretations of law as reflected in court decisions; a study of case law methodology and case research as the decisions impact upon the procedures of the justice system.

4063 LEC BU120 SMITH S 3.40 3.0 MW 0230P-0350P

**AJ 14 Criminal Law**

**Advisory:** Eligible for English 250 and English 260.  
**Transferable:** CSU; UC; CAN: AJ 4

Historical development, philosophy of law and constitutional provisions; definitions, classifications of crime, and their applications to the system of administration of justice; legal research, review of case law, methodology, and concepts of law as a social force. Explores crimes against persons, property, and the state.

4064 LEC BU118 SMITH S 3.40 3.0 TuTh 0810A-0935A

**AJ 16 Introduction to Evidence**

**Advisory:** Eligible for English 250 and English 260.  
**Transferable:** CSU

Origin, development, philosophy and constitutional basis of evidence; constitutional and procedural considerations affecting arrest, search and seizure; kinds and degrees of evidence and rules governing admissibility; judicial decisions interpreting individual rights and case studies viewed from a conceptual level.

4065 LEC BU118 STAFF 3.40 3.0 TuTh 0945A-1110A



**ACCT/CSIS 120**  
**Computerized Accounting**

using *QuickBooks Pro*  
Business Accounting Software

Now offered in Morgan Hill and Hollister.

New morning class offered on the Gilroy main campus!

Content includes general ledger, sales journal, cash receipts journal, cash payments journal, purchases journal, payroll, receivables, payables and related financial reports.

**Footnotes contain valuable information pertaining to your class selection. Footnotes follow class listings.**

Sect. Type Room Instructor Hrs. Units Days Begin-End Footnotes

## AJ 18 Community and Human Relations

**Advisory:** Eligible for English 250 and English 260.  
**Transferable:** CSU; UC

The relationship of criminal justice agents and the community; causal and symptomatic aspects of community understanding; lack of cooperation and mistrust; study of behavioral causes; ways to develop and maintain amicable relationships.

6010	LEC	MHG3	JONES W	3.40	3.0	M	0630P-0940P
Above class meets at Morgan Hill Community site							

## AJ 20 Juvenile Law and Procedure

**Advisory:** Eligible for English 250 and English 260.  
**Transferable:** CSU

Techniques of handling juvenile offenders and victims; prevention and repression of delinquency; diagnosis and referral; organization of community resources. Juvenile law and juvenile court procedure.

6011	LEC	MHG3	JONES W	3.40	3.0	W	0630P-0940P
Above class meets at Morgan Hill Community site							

## AJ 21 Narcotics and Drug Abuse

**Advisory:** Eligible for English 250 and English 260.  
**Transferable:** CSU

Designed to explore the Administration of Justice system and drug problems: drug identification, drug user recognition, drug effects, narcotic enforcement, drug prosecution, drug treatment, rehabilitation and education.

4066	LEC	BU120	SMITHS S	3.40	3.0	MW	0945A-1110A
------	-----	-------	----------	------	-----	----	-------------

## AJ 176 Criminal Street Gangs

**Advisory:** Eligible for English 250 and English 260.  
**Transferable:** CSU

This course is designed to explore historical developments, origins, philosophy and current trends and activities in criminal street gangs within California; explore areas of violence, recruitment, drug use, graffiti and attire; emphasis placed on organization within gangs and racial backgrounds including types of solutions in the criminal justice system use to combat street gangs.

6012	LEC	SS210	PULIDO D	3.40	3.0	Th	0600P-0910P
------	-----	-------	----------	------	-----	----	-------------

## AJ 190 Occupational Work Experience/Administration of Justice

**Required:** Declared vocational major. Concurrent enrollment in seven or more units (including CWE units, except for summer school. For summer school, enrollment in one other class is required). Minimum 2.00 G.P.A.  
**Transferable:** CSU

College credit for learning experience obtained on the job in accordance with a training plan developed cooperatively between the employer, college and student. 75 hours per semester per unit or 60 hours per semester for unpaid experience. This is a credit/no credit course. May be taken for a maximum of 16 work experience units.

4068	WEX	BU125	KERR L	5.60	1.0	DHR	0000-0000	16
4069	WEX	BU125	KERR L	15.00	3.0	DHR	0000-0000	16
4070	WEX	BU125	KERR L	11.30	2.0	DHR	0000-0000	16
4071	WEX	BU125	KERR L	22.50	4.0	DHR	0000-0000	16

## Be Aware

You MAY NOT take courses that overlap (courses that meet at the same day and time)!

Sect. Type Room Instructor Hrs. Units Days Begin-End Footnotes

## ALLIED HEALTH

### AH 3 The Person in the Life Cycle

**Prerequisite:** Eligible for English 250 and English 260.  
**Transferable:** CSU; UC; CSU-GE: E2; GAV-GE: E2, F

Interaction of social, emotional, intellectual, and physical attributes related to the development and realization of human potential across the life span.

4031	LEC	LS104	LOGAN C	3.40	3.0	Th	1255P-0400P
------	-----	-------	---------	------	-----	----	-------------

4032	LEC	LS104	DUFRESNE	3.40	3.0	Th	0410P-0710P
------	-----	-------	----------	------	-----	----	-------------

4033	ONLINE	BEDELL K		3.40	3.0	DHR	0000-0000	38
------	--------	----------	--	------	-----	-----	-----------	----

 This online class will be delivered entirely over the internet. After enrolling, start the class by going to <http://www.gavilan.edu/disted/>, click on your class link, and email the instructor at [kbedell@gavilan.edu](mailto:kbedell@gavilan.edu). Students who have not begun the class or contacted the instructor by 5 pm on Friday, February 2 will be dropped from the class.

### AH 11 Nutrition

**Prerequisite:** Eligible for English 250 and English 260.  
**Advisory:** Chemistry 30A and Mathematics 205.  
**Transferable:** CSU; UC; CSU-GE: E2; GAV-GE: E2, F; CAN: FCS 2

This course is designed to meet the needs of the Allied Health student and the general education student alike. The major aim of this course is to help the student acquire relevant information about nutrition which they can use professionally and/or personally. The course will cover the practical aspects of normal nutrition, ways to promote sound eating habits throughout the life cycle, and physiological contribution nutrients make to body structure and function. This course is also listed as BIO 11.

4034	LEC	LS104	AKROP M	3.40	3.0	Tu	1255P-0400P	25
------	-----	-------	---------	------	-----	----	-------------	----

4035	LEC	LS104	AKROP M	3.40	3.0	Tu	0410P-0710P	25
------	-----	-------	---------	------	-----	----	-------------	----

4036	ONLINE	AKROP M		3.40	3.0	DHR	0000-0000	2538
------	--------	---------	--	------	-----	-----	-----------	------

 This online class will be delivered entirely over the internet. After enrolling, start the class by going to <http://www.gavilan.edu/disted/>, and email the instructor at [makrop@gavilan.edu](mailto:makrop@gavilan.edu). Students who have not begun the class or contacted the instructor by 5 pm on Monday, February 5 will be dropped from the class.

### AH 16 Intravenous Therapy/Blood Withdrawal

**Prerequisite:** Successful completion of Allied Health 64, Allied Health 44, (with a grade of C or better) or equivalent.  
**Transferable:** CSU

Theoretical applications and clinical experience to safely administer intravenous therapy. Principles and practices in intravenous therapy. (Approved by the Board of Vocational Nursing for certification in IV Therapy and Blood Withdrawal.) Approved for 36 hours of continuing education credit. (BRN #00892)

4037	LEC	HOB114	STUBBLEFIELD	7.00	2.0	MTuWTh	0900A-0400P	1155
06/04/06 - 06/14/06								

### AH 23 Independent Study

**Required:** The study outline prepared by the student and the instructor must be filed with the department and the dean.  
**Transferable:** CSU

Designed to afford selected students specialized opportunities for exploring areas at the independent study level. The courses may involve extensive library work, research in the community, or special projects. May be repeated until six units of credit are accrued. This course has the option of a letter grade or credit/no credit.

4038	IND	HOB104	BEDELL K	3.40	1.0	DHR	0000-0000	22
------	-----	--------	----------	------	-----	-----	-----------	----

Sect. Type Room Instructor Hrs. Units Days Begin-End Footnotes

**AH 30 Standard First Aid and Cardiopulmonary Resuscitation**

Transferable: CSU; UC; GAV-GE: E2

First aid training to prepare people to meet the needs of emergencies when medical assistance is delayed. Incorporates the techniques of cardiopulmonary resuscitation. Includes information on the care of wounds, fractures, burns, poisoning, shock, as well as elementary rescue transportation. A satisfactory grade qualifies the student for a Red Cross Standard First Aid card and the Red Cross CPR card. May be repeated three times for credit.

4039 LEC LS104 LOGAN C 2.30 2.0 W 0945A-1150A

**AH 32 Basic Cardiac Life Support**

Transferable: CSU

Course designed to teach students skills in adult, child and infant cardiopulmonary resuscitation. Specifically designed for health professionals. Successful completion will result in certification by the American Heart Association or American Red Cross. This is a credit/no credit course. May be repeated up to three times for credit.

6007 LEC HOB114 LOGAN C 18.00 1.0 SAT/SUN 0800A-0500P 11 32  
02/10/07 - 02/11/07

6008 LEC HOB114 LOGAN C 18.00 1.0 SAT/SUN 0800A-0500P 11 32  
03/03/07 - 03/04/07

**AH 44 Compensatory Nursing Practice**

Prerequisite: Successful completion of Allied Health 43 and an active valid, unrestricted California LVN license.

Transferable: CSU

Concepts and principles of the nursing process applied to preventive, remedial, supportive, rehabilitative, and teaching aspects in meeting the health needs of the patient requiring compensatory nursing interventions. Incorporates nursing concepts and experiences with all age groups, including senior adults.

4041 L/L HOB102 TURNER S 21.40 10.0 WTh 1010A-0100P 93  
BEDELL K  
TURNER S MTu 0210P-1000P  
STAFF

**AH 62 Medical-Surgical Nursing**

Prerequisite: Successful completion of Allied Health 61 with a grade of C or better or equivalent. Equivalency determined by written and performance exams.

Transferable: CSU

Course is designed to provide both theoretical and clinical experience in the care of adult, medical-surgical clients. This course will further refine basic nursing skills and introduce more complicated nursing situations. Content includes pre-operative and post-operative care of the client with pain, cancer, and care of the client with disorders of the musculoskeletal, integumentary, gastrointestinal, and respiratory systems. Related pharmacology is included.

4042 L/L HOB102 STUBBLEFIELD 23.70 11.0 WTh 0710A-1000A 93  
BEDELL K  
STUBBLEFIELD MTu 0630A-0200P  
BEDELL K

**AH 64 Medical-Surgical/Pediatric Nursing**

Prerequisite: Successful completion of AH 61, 62, and 63 with a grade of C or better or equivalent. Equivalency determined by written and performance exams.

Transferable: CSU

Course contains two components to provide theoretical and clinical experience in medical surgical and pediatric nursing. Content includes care of clients with disorders of the endocrine and neurosensory systems, mental illness, emergency nursing and care of the child, including preventive measures and health teaching. A leadership component is included to prepare the student for the realistic work assignment of the licensed vocational nurse. Related pharmacology is included.

4043 L/L HOB102 AMARO D 23.70 11.0 WTh 0110P-0400P 93  
BEDELL K  
AMARO D MTu 0630A-0200P  
BEDELL K 0200P-0930P

Sect. Type Room Instructor Hrs. Units Days Begin-End Footnotes

**AH 140 Online Health Research**

Transferable: CSU

A beginning course on how to find reliable, current health-related information, using the Internet and other electronic resources.

4044 LEC ONLINE MEADERS 4.60 2.0 DHR 0000-0000 11 25 38  
03/26/07-05/21/07

This online class will be delivered entirely over the internet. After enrolling, start the class by going to <http://www.gavilan.edu/disted/>, click on your class link, and email the instructor at [smeader@gavilan.edu](mailto:smeader@gavilan.edu). Students who have not begun the class or contacted the instructor by 5 pm on the third day of the class, will be dropped from the class.



**AH 171 Advanced Clinical Medical Assisting**

Prerequisite: AH 170 with a grade of C or better or equivalent. Equivalency determined by written and performance exams.

Transferable: CSU

Course provides instruction and clinical experience in advanced concepts of clinical medical assisting including specialty procedures and treatments.

4045 L/L HOB114 KEARBEY A 11.30 6.0 TuWTh 0110P-0440P 96

**AH 180 Fundamentals of Nursing--Convalescent**

Prerequisite: Eligible for English 250 and English 260. Clearance from the Department of Health Services (Form HS283), fingerprint card, and health clearance required prior to clinical placement.

Transferable: CSU

A course to provide a basic introduction to patient care in the convalescent setting. Emphasizes principles, understanding and skills necessary to perform basic nursing procedures safely and effectively. Includes introduction to health care, planning, safety, infection control, personal care, basic procedures, rehabilitation, nutrition and clients' rights and needs. At the completion of this course students will qualify for state certification as a nursing assistant.

4046 L/L HOB114 MACHADO M 14.70 8.0 MTu 0900A-1200P 92 94 96  
MACHADO M W 0630A-0130P  
4047 L/L HOB114 MACHADO M 14.70 8.0 MTu 0900A-1200P 92 94 96  
MACHADO M Th 0630A-0130P  
4048 L/L HOB114 MACHADO M 14.70 8.0 MTu 0900A-1200P 92 94 96  
MACHADO M F 0630A-0130P

**EOPS**  
MAKING DREAMS REALITY

Extended Opportunity Programs & Services

Provides an accessible and rewarding college experience to low-income students facing social, economic and educational disadvantages.

You may be eligible for the following services:

- Grant Money
- Priority Registration
- Counseling
- Book Vouchers
- Book Lending Library and many other services

408-848-4740  
Rms. L101A & L101B

Footnotes contain valuable information pertaining to your class selection. Footnotes follow class listings.

Sect. Type Room Instructor Hrs. Units Days Begin-End Footnotes

**AH 190 Occupational Work Experience/Allied Health**

**Required:** Declared vocational major. Concurrent enrollment in seven or more units (including CWE units, except for summer school. For summer school, enrollment in one other class is required). Minimum 2.00 G.P.A.

**Transferable:** CSU

College credit for learning experience obtained on the job in accordance with a training plan developed cooperatively between the employer, college and student. 75 hours per semester per unit or 60 hours per semester for unpaid experience. This is a credit/no credit course. May be taken for a maximum of 16 work experience units.

4049	WEX	HOB114	BEDELL K	5.60	1.0	TBA	0000-0000	76
4050	WEX	HOB114	BEDELL K	11.30	2.0	TBA	0000-0000	76
4051	WEX	HOB114	BEDELL K	16.90	3.0	TBA	0000-0000	76
4052	WEX	HOB114	BEDELL K	22.50	4.0	TBA	0000-0000	76

**Anatomy: see Biological Sciences**

**ANTHROPOLOGY**

**ANTH 1 Introduction to Physical Anthropology**

**Advisory:** English 250, English 260 and Mathematics 205.

**Transferable:** CSU; UC; CSU-GE: B2; IGETC: 5B; GAV-GE: B2; CAN: ANTH 2

Survey study of human biological, social and cultural development over the last several million years. The implications of evolutionary theory for the world today are also considered. Principal topics are evolutionary theory, Mendelian and molecular genetics, the fossil record, primatology, the nature of human diversity "race", and the question of continuing evolution.

4079	LEC	SS210	KLEIN D	3.40	3.0	MW	1120A-1245P	
4080		ONLINE	KLEIN D	3.40	3.0	DHR	0000-0000	38

 This online class will be delivered entirely over the internet. After enrolling, start the class by going to <http://www.gavilan.edu/disted/>, click on your class link, and email the instructor at [dklein@gavilan.edu](mailto:dklein@gavilan.edu). Students who have not begun the class or contacted the instructor by 5 pm on Monday, February 5 will be dropped from the class.

6013	LEC	MHG10	ETLER D	3.40	3.0	Tu	0630P-0940P	
Above class meets at Morgan Hill Community site								

**ANTH 3 Introduction to Cultural Anthropology**

**Advisory:** Eligible for English 250 and English 260.

**Transferable:** CSU; UC; CSU-GE: D1; IGETC: 4A; GAV-GE: D2, F; CAN: ANTH 4

The comparative study of human societies and cultures. Emphasis is placed on the analysis of small scale non-western societies. Specific topics include the nature of culture, the enculturation process, kinship systems and the cross-cultural analysis of religious, political and economic institutions. Culture change and the relevance of anthropology for understanding the modern world are also considered.

4081	LEC	SS205	KLEIN D	3.40	3.0	TuTh	0945A-1110A	
4082	LEC	SS205	KLEIN D	3.40	3.0	MW	1255P-0220P	

**ANTH 5 Magic, Witchcraft and Religion**

**Advisory:** English 250 and English 260.

**Transferable:** CSU; UC; CSU-GE: D1; IGETC: 4A; GAV-GE: D2

Cross cultural study of beliefs and practices with respect to the supernatural, health/wellness and healing, myth, ritual, witchcraft, magic, symbolism, altered states of consciousness, and revitalization. Also connection and reflection of cultural contexts in which they are found.

4083	LEC	SS210	KLEIN D	3.40	3.0	TuTh	1120A-1245P	
------	-----	-------	---------	------	-----	------	-------------	--

Sect. Type Room Instructor Hrs. Units Days Begin-End Footnotes

**ART**

**ART 1A Art History**

**Advisory:** Eligible for English 250 and English 260.

**Transferable:** CSU; UC; CSU-GE: C1; IGETC: 3A; GAV-GE: C1; CAN: ART 2, ART SEQ. A

A critical survey of the influences and development of painting, architecture, sculpture, and minor arts from pre-history to the Byzantine/Romanesque eras, including the art of primitive people.

6014	LEC	MHG11	STOLAR S	3.40	3.0	W	0630P-0940P	
Above class meets at Morgan Hill Community site								

**ART 1B Art History**

**Advisory:** Eligible for English 250 and English 260.

**Transferable:** CSU; UC; CSU-GE: C1; IGETC: 3A; GAV-GE: C1; CAN: ART 4, ART SEQ. A

The history of western painting, sculpture, architecture and minor arts from the Romanesque, the Gothic and Renaissance eras to the present.

4084	LEC	AL101	ROIZEN M	3.40	3.0	TuTh	0810A-0935A	1
4880	LEC	HOL 4	STAFF	3.40	3.0	MW	1255P-0220P	
Class meets at the Hollister Briggs site								

**ART 2A Two-Dimensional Design**

**Transferable:** CSU; UC; CSU-GE: C1; GAV-GE: C1; CAN: ART 14

An introduction to the basic elements and principles of two-dimensional design. Lettering and graphics applications of design are included. Traditional and experimental materials and techniques are applied to a variety of individual projects and exercises.

4085	L/L	AR103	THOMAS B	6.80	3.0	MW	0810A-1115A	1
------	-----	-------	----------	------	-----	----	-------------	---

**ART 3A Drawing and Composition**

**Transferable:** CSU; UC; CSU-GE: C1; GAV-GE: C1; CAN: ART 8

A course that can teach you how to draw. Students learn basic drawing skills through the exploration of a variety of drawing materials such as pencil, inks, charcoal and pastels; processes include doodling, gesture and schematic drawing.

4086	L/L	AR102	R2ROW	6.80	3.0	MW	1120A-0225P	1
4087	L/L	AR102	STOLAR S	6.80	3.0	TuTh	1120A-0225P	1

**ART 3B Drawing and Composition**

**Advisory:** Art 2A or 3A.

**Transferable:** CSU; UC; GAV-GE: C1

Drawing in pencil, ink, pastels and variety of experimental materials and processes. Cultural awareness and historical foundations are integrated with classroom explorations of expressive drawing. Students develop a variety of drawing approaches and a greater understanding of personal expression. May be repeated once for credit. This course has the option of a letter grade or credit/no credit.

4088	L/L	AR102	R2ROW	4.50	3.0	TuTh&2.3	0900A-1105A	
------	-----	-------	-------	------	-----	----------	-------------	--

**ART 6 Art Appreciation**

**Advisory:** English 250 and English 260.

**Transferable:** CSU; UC; CSU-GE: C1; IGETC: 3A; GAV-GE: C1

An illustrated lecture course that surveys and introduces the visual arts from historical to contemporary times, and teaches students the basic concepts of seeing and appreciating art.

4089	LEC	AL101	EDBERG J	3.40	3.0	MW	1120A-1245P	1
4090	LEC	MHG4	ROIZEN M	3.40	3.0	TuTh	1120A-1245P	
Above class meets at Morgan Hill Community site								

4091		ONLINE	EDBERG J	3.40	3.0	DHR	0000-0000	38
------	--	--------	----------	------	-----	-----	-----------	----

 This online class will be delivered entirely over the internet. After enrolling, start the class by going to <http://www.gavilan.edu/disted/>, click on your class link, and email the instructor at [jedberg@gavilan.edu](mailto:jedberg@gavilan.edu). Students who have not begun the class or contacted the instructor by 5 pm on Monday, February 5 will be dropped from the class.

Sect. Type Room Instructor Hrs. Units Days Begin-End Footnotes

**ART 8A Beginning Photography from Analog to Digital**

Transferable: CSU; UC; CSU-GE: C1; GAV-GE: C1; CAN: ART 18

A beginning photography course focused on the technical and historical aspects of photography from analog to digital. This course includes the development of personal artistic expression and visual perception through the use of various photographic medium. The course will include lectures and discussions about composition and content, analog and digital camera use, lighting and exposure, various photographic processes, and photographic presentation techniques. Alternative methods, mixed media and experimental forms of photography will also be discussed. Students will be required to provide their own camera, and film.

4092 L/L AR103 EDBERG J 6.80 3.0 TuTh 1120A-0225P

**ART 10A Cultural History of Ceramics**

Transferable: CSU; UC; CSU-GE: C1; GAV-GE: C1, F; CAN: ART 6

An introduction to the historical developments and cultural influences of ceramic art. Development of a personal expression is realized through the combination of historical elements, observation and actual creations in clay.

4093 L/L AR101 REKEDAL J 5.70 3.0 MW 0840A-1110A

6016 L/L AR101 GONZALES KC 3.40 3.0 S&2.3 0900A-1210P 54  
 This hybrid lecture/online class will be delivered partially over the internet. See the online syllabus for details. <http://www.gavilan.edu/disted/>. Mandatory open lab will be held on Saturday mornings.

6017 L/L AR101 GONZALES KC 5.70 3.0 TuTh 0600P-0830P

**ART 10B Ceramics**

Advisory: Art 10A

Transferable: CSU; UC; GAV-GE: C1

Emphasis on development of wheel throwing and advanced ceramic techniques. Glaze testing, clay body development, kiln stacking and firing are introduced. May be repeated three times for credit. This course has the option of a letter grade or credit/no credit.

4094 L/L AR101 REKEDAL J 6.80 3.0 MW 1120A-0225P

6018 L/L AR101 GONZALES KC 6.80 3.0 TuTh 0600P-0910P

**ART 11 Creativity, Imagination, and Innovation**

Advisory: English 250 and English 260.

Transferable: CSU; CSU-GE: C2; GAV-GE: C2, F

This course is designed to explore the variety of ways in which humans demonstrate their creative, imaginative and innovative abilities. This course will examine the creative process, visual literacy, the development of creative and imaginative performance and theories pertaining to insight, inspiration, intuition, originality and genius. This class draws on materials from a variety of sources including, biographies, intellectual histories, psychological studies, and educational research. Studies will include ideas and beliefs about creativity from a diverse range of disciplines and cultures. Students will be encouraged to explore and express their own creativity.

4095 LEC AR103 JUNCKER A 3.40 3.0 MW 1120A-1245P

**ART 12A Sculpture**

Transferable: CSU; UC; GAV-GE: C1; CAN: ART 12

An introduction to expressive and technical sculptural processes of selected media such as clay, plaster and wood. May be repeated once for credit. This course has the option of a letter grade or credit/no credit.

4096 L/L AR101 ALLEN F 4.40 2.0 F 0900A-0105P

**ART 14 Beginning Mural Painting**

Transferable: CSU; UC; CSU-GE: C1; GAV-GE: C1

Studio practice in the design, methods and materials of mural painting through the production of individual and collaborative murals. The course will also provide a historical survey of mural painting, from pre-historic cave painting to contemporary urban murals, with particular focus on the muralists of Mexico. May be repeated three times for credit. This course has the option of a letter grade or credit/no credit.

4097 L/L GHS R2ROW 4.50 3.0 W&2.3 0315P-0720P 84

This class is part of the High Step program. It will be offered at Gilroy High School, room H-3. This class is open to all students. For more information, see a Gavilan counselor.

**GET INVOLVED!**

Help paint murals in your own community!

**ART 14 Beginning Mural Painting**



This class offers studio practice in the design, methods and production of individual and collaborative murals and a historical survey of mural painting.

Satisfies CSU General Education (Area C-1) and the ARTS Gavilan College graduation requirement (AREA C-1)

**ART 21**  
**Ancient America:**  
**A History Through Art**



Also listed as History 21

ART 21 Satisfies the CSU Humanities requirement (AREA C-2) and the UC/CSU ARTS requirement under the IGETC pattern.

sect. 4098 Mon/Wed 12:55-2:20 pm Instructor: Enrique Luna

**Play dirty! Take ART 10A/B CERAMICS**



**No prerequisites required for ART 10B!**



ART 10A will also be offered as a hybrid lecture/online class. See class listing for details.

ART 10A fulfills the requirement for transfer to CSU and transfers as an elective to UC. ART 10A or 10B fulfill the Gavilan GE requirement for graduation.



Sect.	Type	Room	Instructor	Hrs.	Units	Days	Begin-End	Footnotes
-------	------	------	------------	------	-------	------	-----------	-----------

**ART 21 Ancient Americas: A History through Art****Advisory:** Eligible for English 250.**Transferable:** CSU; UC; CSU-GE: C1; IGETC: 3A; GAV-GE: C2, F

A critical survey of history through the arts of pre-Columbian natives of North, Central and South America. The course will cover major societies and events from the appearance of major civilizations through the initial colonization efforts of European nations. Due to the distinct history of the Americas, this course uses the arts - architecture, sculpture, ceramics and painting, among others - of ancient societies as a primary source material. This course has the option of a letter grade or credit/no credit. This course is also listed as HIST 21.

4098	LEC	SS205	LUNA E	3.40	3.0	TuTh	0230P-0355P	25
------	-----	-------	--------	------	-----	------	-------------	----

**ART 22 Field Work and Service****Required:** Learning contracts must be filled out and signed by the student and the supervising instructor.**Transferable:** CSU

Supervised field work within the college and with local agencies. Students serve in useful group activities in leadership roles prescribed for them by faculty or community agencies. A maximum of six units may be completed. This is a credit/no credit course.

4099	FEX	AR101	GONZALES KC	1.70	.5	DHR	0000-0000	
4100	FEX	AR104	EDBERG J	3.40	1.0	DHR	0000-0000	
4101	FEX	AR101	REKEDAL J	3.40	1.0	DHR	0000-0000	
4102	FEX	AR102	ROIZEN M	3.40	1.0	DHR	0000-0000	
4103	FEX	AR109	R2ROW	3.40	1.0	DHR	0000-0000	

**ART 23 Independent Study****Required:** The study outline prepared by the student and the instructor must be filed with the department and the dean.**Transferable:** CSU

Designed to afford selected students specialized opportunities for exploring areas at the independent study level. The courses may involve extensive library work, research in the community, or special projects. May be repeated until six units of credit are accrued. This course has the option of a letter grade or credit/no credit.

4104	IND	AR101	GONZALES KC	3.40	1.0	DHR	0000-0000	
4105	IND	AR102	STOLAR S	3.40	1.0	DHR	0000-0000	
4106	IND	AR104	EDBERG J	3.40	1.0	DHR	0000-0000	
4107	IND	AR104	EDBERG J	6.80	2.0	DHR	0000-0000	
4108	IND	AR101	REKEDAL J	3.40	1.0	DHR	0000-0000	
4109	IND	AR101	REKEDAL J	6.80	2.0	DHR	0000-0000	
4110	IND	AR101	ALLEN F	3.40	1.0	DHR	0000-0000	
4111	IND	AR102	ROIZEN M	3.40	1.0	DHR	0000-0000	
4112	IND	AR102	ROIZEN M	6.80	2.0	DHR	0000-0000	
4113	IND	AR109	R2ROW	3.40	1.0	DHR	0000-0000	
4114	IND	AR109	R2ROW	6.80	2.0	DHR	0000-0000	
4115	IND	AR102	STOLAR S	6.40	2.0	DHR	0000-0000	

**ART 25A Art Methods****Transferable:** CSU; CSU-GE: C1; GAV-GE: C1

Art methods and learning theory for those planning to work with preschool, elementary and secondary school students. Includes art therapy as well as gifted and special learner projects. Two dimensional work in printing, drawing, collage. Also listed as CD 25A.

6020	L/L	HOL1	MCGINNIS R	4.50	3.0	F&2.3	0400P-0815P	25
Above class meets at the Hollister Briggs site								

Sect.	Type	Room	Instructor	Hrs.	Units	Days	Begin-End	Footnotes
-------	------	------	------------	------	-------	------	-----------	-----------

**ART 25B Art Methods****Transferable:** CSU; GAV-GE: C1

Art methods, creativity and learning theory for those planning to work with preschool, elementary, and secondary school students. Includes art therapy as well as gifted and special learner projects. Three dimensional work in sculpture, bas relief, mobiles, paper mache', plaster, and various 3-D materials. Also listed as CD 25B.

6021	L/L	HOL1	MCGINNIS R	4.50	3.0	F&2.3	0400P-0815P	25
Above class meets at the Hollister Briggs site								

**ART 40 Art Gallery Assistance****Transferable:** CSU; GAV-GE: C1

Individualized course in art gallery exhibition techniques and procedures. Students assist in design, installation, publicity, cataloguing and removal of exhibitions in the college gallery. May be taken until 4 units are accrued.

4116	FEX	AR109	R2ROW	3.40	1.0	TBA	0000-0000	21
------	-----	-------	-------	------	-----	-----	-----------	----

**ART 74 Advanced Photoshop****Advisory:** CSIS 75 PhotoShop I**Transferable:** CSU; GAV-GE: C1

This course is for the PhotoShop-experienced student and explores PhotoShop's advanced features in depth. Students work on projects, which challenge their creativity and technical ability, and will be encouraged to develop complex projects for the web and for the printed page. May be repeated three times for credit. This course has the option of a letter grade or credit/no credit. This course is also listed as CSIS 74 and DM 74.

6022	LEC	MHG8	GRZAN R	3.40	3.0	Th	0630P-0940P	25
Above class meets at Morgan Hill Community site								

**ART 75 PhotoShop I****Advisory:** CSIS 124 (Windows Fundamentals), CSIS 2L**Transferable:** CSU; GAV-GE: C1

This course is based on the software Adobe PhotoShop. Students learn to scan photographs and manipulate them using PhotoShop tool box and special effects filters. They will learn to color correct photos; mask image using channels; create duotone, tritone, and quadtone images; prepare photos for use in printing and on the web. This course has the option of a letter grade or credit/no credit.

4117	L/L	LI128	BEEDER	5.70	3.0	TuTh&2	1120A-1240P	25 35
------	-----	-------	--------	------	-----	--------	-------------	-------

6023	L/L	MHG8	GRZAN R	5.70	3.0	Tu&2	0630P-0940P	8 25 35
Above class meets at Morgan Hill Community site								

**ART 77 Introduction to Digital Media****Advisory:** CSIS 124, CSIS 1, CSIS 2.2L, CSIS 3, or familiarity using the Macintosh or Windows operating systems.**Transferable:** CSU; UC; GAV-GE: C1

An introduction to the field of digital media, including history, social impact, concepts, career options and industry trends. Applying learned visual and aural design principles, students will explore the use of computer-based tools in the design and production of digital media by creating and editing digital images, sounds, video, animation and text. A comprehensive term project for publication on the web or CD ROM will be required. This course is also listed as CSIS 77 and DM 77. This course has the option of a letter grade or credit/no credit. May be repeated twice for credit.

4118	L/L	LI128	BEEDER	5.70	3.0	TuTh&2	0945A-1110A	25 35
------	-----	-------	--------	------	-----	--------	-------------	-------

## The Final Word!

Look for the Final Exams schedule on page 120 of this schedule.

Sect. Type Room Instructor Hrs. Units Days Begin-End Footnotes

Sect. Type Room Instructor Hrs. Units Days Begin-End Footnotes

**ART 80 Digital Photography**

**Advisory:** CSIS 1 or CSIS 2/2L or ART 8A or equivalent computer experience.  
**Transferable:** CSU; UC; GAV-GE: C1

The study of digital photography from digital camera to the computer-based printer or digital media. Artistic, theoretical, and technical aspects will be considered. Topics include information about types and purchasing of digital cameras; theory, mechanics, and art of digital imagery; digital darkroom; eccentricities of digital photo taking; stitching photos for virtual reality; and preparing digital images for print, World Wide Web and other digital media. This course has the option of a letter grade or credit/no credit. This course is also listed as DM 80 and CSIS 80.

4119 L/L LI128 EDBERG J 5.70 3.0 MW 1255P-0325P 25 35

**ART 85 Web Design I: Dreamweaver**

**Advisory:** CSIS 6 or basic knowledge of HTML.  
**Transferable:** CSU; GAV-GE: C1

Basic and intermediate principles of designing Web pages/sites using the Dreamweaver web design software and HTML. Emphasis will be on good design and the use of tables, frames, forms, rollovers, DHTML, XHTML, behaviors, and CSS. Also includes site maintenance and the integration of multimedia components such as graphics, sound, animation, and video. This course is for the content person to design, develop, and maintain effective Web sites. This course is also listed as CSIS 85 and DM 85. This course has the option of a letter grade or credit/no credit. May be repeated twice for credit.

4120 LEC MHG8 CONREY J 3.30 2.0 Tu 1120A-0225P 11 25  
 02/06/07-05/01/07 Above class meets at Morgan Hill Community site

**ART 108 Digital Media Lab**

**Advisory:** CSIS 1 or CSIS 2/2L or equivalent computer experience.  
**Transferable:** CSU; GAV-GE: C1

Supervised practice and individualized computer assisted learning of software applications and techniques commonly found in the design and production of digital media (e.g., digital art and imaging, digital photography, digital print, digital audio/video, web design/authoring, DVD/CD ROMs, animation). Supplements lecture courses. Open entry/exit, so may be added at anytime during the semester. This is a credit/no credit course. May be repeated three times for credit. Also listed as DM 108 and CSIS 108.

4121 LAB LI128 BEEDE R 1.70 .5 M 1110A-1245P 25 31

**ART 114 Digital Media Production**

**Advisory:** At least one of the following: ART 75, GBUS 80, CGD 2, JOUR 18A, MUS 21, CSIS 7, CSIS 71 OR CSIS 77. or students must possess equivalent skills from any one of the following areas: digital media, computer graphics, digital print, journalism (publishing), film, TV/video, drawing or illustration, web design/development, business/marketing, or programming.  
**Transferable:** CSU; GAV-GE: C1

A team oriented practicum that focuses on the application of learned skills to the production of digital media and digital print projects, such as web sites, CD ROM, and DVDs, Project development will be accomplished according to team derived master schedules. Lectures will be on project management, work coordination and production techniques, client-team interface, asset management and integration, budget estimate, testing, and copyright infringement. Please note that this is very much a team oriented class. This course has the option of a letter grade or credit/no credit. This course is also listed as CSIS 114 and DM 114.

4122 LEC LI128 BEEDE R 2.30 2.0 F 1110A-0115P 25

**ART 117 Motion Graphics/Special Effects**

**Advisory:** DM/ART/CSIS 113 or DM/ART/CSIS 140 or DM/ART/CSIS 77 or THEA 17A or basic knowledge of digital video/film editing.  
**Transferable:** CSU; UC; GAV-GE: C1

Study of the design of motion graphics and special effects used in digital video and film, web, multimedia, and interactive games. Includes video/graphics compositing techniques, 2D animation, basic 3D animation, and special effects commonly generated in digital post-production. Software such as Adobe After Effects or Apple's Motion will be used. May be repeated for credit. This course has the option of a letter grade or credit/non-credit. This course is also listed as CSIS 117 and DM 117.

4123 L/L LI128 BEEDE R 5.70 3.0 MW 0945A-1110A 25 31

**ART 140 Basic Digital Film/Video Production**

**Transferable:** CSU; UC; GAV-GE: C1

An on-line self-paced course covering the basics of film/video production and post production (editing) using "easy to use" computer software such as Apple's iMovie. Beneficial for students who are producing a video/film project as a requirement for another college course, extra skills development, or for self interest. Completion of the associated class or personal project in DVD format using either personal video equipment or the equipment in the Digital Media Studio is required. May be repeated twice for credit. This course has the option of a letter grade or credit/no credit. This course is also listed as DM 140 and CSIS 140.

4124 ONLINE BEEDE R 1.00 1.0 DHR 0000-0000 25 38  
 This online class will be delivered entirely over the internet. After enrolling, start the class by going to <http://www.gavilan.edu/disted/>, click on your class link, and email the instructor at [rbeede@gavilan.edu](mailto:rbeede@gavilan.edu). Students who have not begun the class or contacted the instructor by 5 pm on Monday, February 5 will be dropped from the class.

**ART 190 Occupational Work Experience/Commercial Art**

**Required:** Enrollment in a minimum of seven (7) units, including Cooperative Work Experience, during regular semesters; enrollment in at least one other class in summer session.  
**Transferable:** CSU; GAV-GE: C1

The application of learned theory, knowledge, and skills to a practical job setting related to the student's educational/occupational goal. Employment must be directly related to the student's college educational/occupational goal. Periodic interviews of the students and employers or their representatives will be required. Each student shall be assisted in the development of individualized performance objectives, toward which the learning experience shall be directed.

4125 WEX BU125 KERR L 5.60 1.0 DHR 0000-0000  
 4126 WEX BU125 KERR L 11.30 2.0 DHR 0000-0000  
 4127 WEX BU125 KERR L 16.90 3.0 DHR 0000-0000  
 4128 WEX BU125 KERR L 22.50 4.0 DHR 0000-0000



**GAVILAN  
COLLEGE  
BOOKSTORE**

**STUDENT CENTER**

- NEW BOOKS
- USED BOOKS (25% LESS THAN NEW)
- BOOK BUY BACK

RETURN Policy  
 Refunds given UP TO SEVEN DAYS from start of class.  
 Always have your receipt.  
 Always make sure new books have not been written in.  
 Shrink wrap sets should be returned with all enclosures.

GET OUT OF LINE • GET ON LINE

Order your textbooks @  
[www.gavilan.BKSTR.com](http://www.gavilan.BKSTR.com)

HOURS		SUMMER HOURS	
Mon - Tues	8:00 a.m. - 7:00 p.m.	Mon - Thur	8:00 a.m. - 3:00 p.m.
Wed - Thurs	8:00 a.m. - 5:00 p.m.	Friday	8:00 a.m. - 1:00 p.m.
Friday	8:00 a.m. - 1:00 p.m.		

408-848-4742

We accept all major credit cards and checks with ID

Sect. Type Room Instructor Hrs. Units Days Begin-End Footnotes

## ASTRONOMY

### ASTR 1 Introduction to General Astronomy

**Advisory:** Mathematics 205 and eligible for English 250 and English 260.  
**Transferable:** CSU; UC; CSU-GE: B1; IGETC: 5A; GAV-GE: B1

An introduction to the realm of astronomy and space science. Topics to be covered include the historical development of astronomy, the physics of gravitation and radiation, the solar system, stellar astronomy, galactic and extragalactic astronomy, and cosmology.

4129	LEC	SS214	BUMGARNER J	3.40	3.0	Tu	0230P-0540P
6025	LEC	MHG3	BUMGARNER J	3.40	3.0	Tu	0630P-0940P Above class meets at Morgan Hill Community site
6026	LEC	LS101	SNYDER J	3.40	3.0	W	0630P-0940P

**Athletics: see Physical Education (PE)**

## AVIATION MAINTENANCE TECHNOLOGY

AMT 101, AMT 111 and AMT 121 begin before the regular spring start date. See dates below.

### AMT 101 General Aircraft Technology

**Advisory:** Mathematics 205  
**Transferable:** CSU

This course will provide the student with a thorough understanding of the use of maintenance publications, maintenance forms and records with emphasis on A & P mechanic privileges and limitations. Basic electricity for aircraft from Ohm's Law through transistor theory will be taught as well as ground operation and servicing of aircraft.

4072	L/L	AV102	CONNALD	14.00	7.5	DAILY	0800A-1030A	1	5	28
01/18/07 - 05/25/07 Above class meets at the Hollister Airport										

### AMT 111 Airframe Structures

**Transferable:** CSU

Aircraft wood, fiberglass construction, fabric covering, testing and repair, aircraft inspection, painting techniques and procedures. Also the study of basic hydraulic systems of anti-skid systems, pneumatic, fixed landing and retractable landing gear systems. Basic aircraft systems familiarization along with advanced laboratory projects from topics covered in AMT 110 are a part of this course.

4073	L/L	AV102	HALL C	25.30	13.5	DAILY	1030A-0330P	1	5	28
01/18/07 - 05/25/07 Above class meets at the Hollister Airport										

### AMT 121 Aviation Powerplant Systems Technology

**Advisory:** Successful completion of AMT 120.  
**Transferable:** CSU

The theory of operation, maintenance, repair, and trouble-shooting procedures of powerplant systems and their relationship to the total powerplant package. To include lubrication, electrical, instrument, fuel metering, fire protection, starting, control systems, and the aerodynamics, theory and maintenance of propellers and their control systems.

4074	L/L	AV102	FLIPPENT	27.00	14.0	TuWThF	0830A-0300P	1	5	28
01/18/07 - 05/25/07 Above class meets at the Hollister Airport										

## DHR and TBA

mean that the class has a flexible schedule. For details, contact the instructor.

Sect. Type Room Instructor Hrs. Units Days Begin-End Footnotes

### AMT 190 Occupational Work Experience/Aviation

**Required:** Declared vocational major. Concurrent in seven or more units (including CWE units, except for summer school. For summer school, enrollment in one other class is required). Minimum 2.00 G.P.A.

**Transferable:** CSU

College credit for learning experience obtained on the job in accordance with a training plan developed cooperatively between the employer, college and student. 75 hours per semester per unit or 60 hours per semester for unpaid experience. This is a credit/no credit course. May be taken for a maximum of 16 units of work experience units.

4075	WEX	BU125	KERR L	5.60	1.0	DHR	0000-0000	16
4076	WEX	BU125	KERR L	11.30	2.0	DHR	0000-0000	16
4077	WEX	BU125	KERR L	16.90	3.0	DHR	0000-0000	16
4078	WEX	BU125	KERR L	22.50	4.0	DHR	0000-0000	

**Beauty School: see Cosmetology**

## BIOLOGICAL SCIENCE

### BIO 5 General Botany

**Prerequisite:** Mathematics 233 with a grade of 'C' or better.

**Advisory:** Biological Science 10, eligible for English 250 and English 260.

**Transferable:** CSU; UC; CSU-GE: B2, B3; IGETC: 5B; GAV-GE: B2, B3; CAN: BIOL 6, BIOL SEQ. A

This course is designed for students majoring in botany and/or its related disciplines. The course includes the study of the ecology, evolution, anatomy, physiology and systematics of plants as well as the use of plants in biotechnology and agriculture.

4134	L/L	LS103	MORALES R	6.80	4.0	TuTh	0810A-0935A	1
							M	0230P-0535P

### BIO 7 Human Anatomy

**Prerequisite:** Biological Science 10 or 15 with a grade of credit or C or better.

**Advisory:** Eligible for English 250, English 260 and Mathematics 205.

**Transferable:** CSU; UC; CSU-GE: B2, B3; IGETC: 5B; GAV-GE: B2, B3; CAN: BIOL 10, BIOL SEQ. B

A functional approach to the gross and microscopic structure of the major systems of the human body. Includes dissection in lab. A cadaver is observed in this course.

4135	L/L	LS103	STAFF	9.10	4.0	WF	1120A-1210P	1
							STAFF	1220P-0325P

### BIO 9 Human Physiology

**Prerequisite:** Biological Science 7 or 15 with a grade of credit or C or better.

**Advisory:** Chemistry 30A; eligible for English 250, English 260 and Mathematics 205.

**Transferable:** CSU; UC; CSU-GE: B2, B3; IGETC: 5B; GAV-GE: B2, B3; CAN: BIOL 12, BIOL SEQ. B

A study of the functions of the major organs and organ systems of the human body, emphasizing control at the cellular level, integration of systems and homeostasis of the human body. This course is also listed as Allied Health 9.

4136	L/L	LS101	MCKENNA M	7.90	5.0	WF	1120A-0125P	1		
							LS103	MCKENNA M	Th	0945A-1250P
4137	L/L	LS101	MCKENNA M	7.90	5.0	WF	1120A-0125P	1		
							LS103	SMITH M	Th	0415P-0720P
4138	L/L	LS101	MCKENNA M	7.90	5.0	WF	1120A-0125P	1		
							LS103	SMITH M	Th	0100P-0405P

## For on-campus child care

contact the Child Development Center at (408) 848-4815

Sect. Type Room Instructor Hrs. Units Days Begin-End Footnotes

**BIO 10 Principles of Biology**

**Advisory:** Eligible for English 250, English 260 and Mathematics 205.  
**Transferable:** CSU; UC; CSU-GE: B2, B3; IGETC: 5B; GAV-GE: B2, B3

An introductory biology course covering functions at the cellular and organismal levels. Includes study of the basic principles of metabolism, heredity, evolution and ecology. Primarily for non-biological science majors.

4139	L/L	SS214 LS102	APODACA M APODACA M	5.70 4.0	MW M	0230P-0350P 0810A-1015A	1
4140	L/L	SS214 LS102	APODACA M APODACA M	5.70 4.0	MW M	0230P-0350P 1040A-1245P	1
4141	L/L	SS214 LS102	APODACA M APODACA M	5.70 4.0	MW W	0230P-0350P 0810A-1015A	1
4142	L/L	SS214 LS102	APODACA M APODACA M	5.70 4.0	MW W	0230P-0350P 1040A-1245P	1
6027	L/L	LS102	GEMAR A	5.70 4.0	M W	0630P-0855P	

**BIO 11 Nutrition**

**Prerequisite:** Eligible for English 250 and English 260  
**Advisory:** Chemistry 30A and Mathematics 205  
**Transferable:** CSU; UC; CSU-GE: E2; GAV-GE: E2; CAN: FCS 2

This course is designed to meet the needs of the Allied Health student and the general education student alike. The major aim of this course is to help the student acquire relevant information about nutrition which they can use professionally and/or personally. The course will cover the practical aspects of normal nutrition, ways to promote sound eating habits throughout the life cycle, and physiological contribution nutrients make to body structure and function. This course is also listed as Allied Health 11.

4143	LEC	LS104	AKROP M	3.40 3.0	Tu	1255P-0400P	25
4144	LEC	LS104	AKROP M	3.40 3.0	Tu	0410P-0710P	25
4145		ONLINE	AKROP M	3.40 3.0	DHR	0000-0000	25 38

 This online class will be delivered entirely over the internet. After enrolling, start the class by going to <http://www.gavilan.edu/disted/>, click on your class link, and email the instructor at makrop@gavilan.edu. Students who have not begun the class or contacted the instructor by 5 pm on Monday, February 5 will be dropped from the class.

**BIO 15 Survey of Human Anatomy and Physiology**

**Advisory:** Biological Science 10, Eligible for English 250, English 260 and Mathematics 205.  
**Transferable:** CSU; UC; CSU-GE: B2, B3; IGETC: 5B; GAV-GE: B2, B3

An introductory study of the structure and function of the human body. Includes study at the cellular and organ system levels, emphasizing integration of systems. Note that a cadaver will be observed in this course. This course is also listed as Allied Health 15.

4146	L/L	LS101 LS103	MCKENNA M MORALES R	7.90 5.0	MW Tu	0845A-1050A 0100P-0405P	1 25 77
4147	L/L	LS101 LS103	MCKENNA M MCKENNA M	7.90 5.0	MW Tu	0845A-1050A 0945A-1250P	1 25 77
4148	L/L	LS101 LS103	MCKENNA M MCKENNA M	7.90 5.0	MW M	0845A-1050A 1120A-0225P	1 25 77

6028 L/L LS103 MORALES R 3.40 5.0 W&4.5 0600P-0905P 13  
 This hybrid lecture/online class will be delivered partially over the internet. See the online syllabus for details. <http://www.gavilan.edu/disted/>.

**BIO 21 Field Ecology**

**Advisory:** Eligible for English 250 and Math 205.  
**Transferable:** CSU

Introduces concepts in ecology, plant and animal identification, natural history, and habitat assessment in a field setting. The class will have a two hour meeting on a Monday evening to prepare for two outings on two successive Saturdays to local habitats. Camping is not required. Outings will be rescheduled in the case of inclement weather.

6029	LEC	LS101	WILLETT T WILLETT T WILLETT T	1.00 1.0	M SAT SAT	0630P-0830P 0800A-0600P 0800A-0600P	
------	-----	-------	-------------------------------------	----------	-----------------	---	--

04/16/07 - 04/28/07

# The Sky is the Limit!

at the **Gavilan Aviation Maintenance Technology Program**



- Unlimited employment opportunities
- Graduates can earn up to \$30/hour
- Internships available
- Accredited by the Federal Aviation Administration
- Receive both Airframe and Powerplant Licenses in 4 semesters
- Fast and easy commute to training program

For complete program information please contact the Aviation Department at the Hollister Airport (831) 637-1151 or the Technical and Public Services Division at Gavilan (408) 848-4719.

**Train for a Career in Biotechnology**

## San Joaquin Biotechnology Center



Biotechnology, two definitions...

- ◆ Application of living organisms or their products to enhance the human condition.
- ◆ Application of scientific advances in the life sciences to create commercial products and services.

**Careers for those with a biotechnology certificate or AA degree:**

- ◆ Assay analysts
- ◆ Laboratory assistant or technicians
- ◆ Manufacturing technician
- ◆ QA/QC technician

**In addition to the biotechnology industry, jobs for technicians can be found in:**

- ◆ Food processing
- ◆ Forensic labs
- ◆ Hospitals
- ◆ Research labs
- ◆ Seed companies
- ◆ Wineries



This semester take

**BIOT 104**  
Seminar in Biotechnology

See next page for class details.



[www.gavilan-sjbc.org](http://www.gavilan-sjbc.org)

**Footnotes contain valuable information pertaining to your class selection. Footnotes follow class listings.**

Sect. Type Room Instructor Hrs. Units Days Begin-End Footnotes

**BIO 23 Independent Study**

**Required:** The study outline prepared by the student and the instructor must be filed with the department and the dean.

**Transferable:** CSU

Designed to afford selected students specialized opportunities for exploring areas at the independent study level. The courses may involve extensive library work, research in the community, or special projects. May be repeated until six units of credit are accrued. This course has the option of a letter grade or credit/no credit.

4149	IND	LS109	MCKENNA M	6.80	2.0	DHR	0000-0000	22
4150	IND	LS110	MCKENNA M	3.40	1.0	DHR	0000-0000	22

**BIOTECHNOLOGY**



**BIOT 104 Seminar in Biotechnology**

**Transferable:** CSU

This course will survey careers in biotechnology and ethical issues in biotechnology.

6030	LEC	LS103	MORALES R	1.00	1.0	Tu	0630P-0730P	
------	-----	-------	-----------	------	-----	----	-------------	--

**Business Accounting: see Accounting**

**BUSINESS, GENERAL**

**GBUS 1 Fundamentals of Business**

**Advisory:** Eligible for English 250 and English 260.

**Transferable:** CSU; UC; GAV-GE: D2

This course introduces students to business and the array of opportunities that it offers. The course will help students recognize careers that will be of interest to them with consideration of their own skills and aptitudes. Different facets of business will be covered and students will learn about establishing their own business. This course has the option of a letter grade or credit/no credit.

4415	LEC	HOL5	ROSS Y	3.40	3.0	MW	1240P-0200P	
Above class meets at the Hollister Briggs site								
4416	LEC	BU120	STAFF	3.40	3.0	TuTh	1255P-0210P	

**GBUS 11 Statistics for Business and Economics**

**Prerequisite:** Mathematics 233.

**Transferable:** CSU; UC; CSU-GE: B4; IGETC: 2A; GAV-GE: B4

Statistical methods for business/economics analysis; descriptive statistics, inference, correlation and regression, probability, time series analysis. This course has the option of a letter grade or credit/no credit. This course is also listed as ECON 11.

6116	LEC	BU118	STAFF	4.50	4.0	MW	0600P-0805P	25
------	-----	-------	-------	------	-----	----	-------------	----



**GBUS 14 Personal Finance**

**Advisory:** Math 400

**Transferable:** CSU

This course is designed to assist individuals to analyze their financial affairs for lifelong decision making. Elements and concepts of financial planning and decision making in the areas of budgeting, taxes, borrowing, money management, insurance, investments, retirement, and estate planning will be examined. This course is also listed as ECON 14. This course has the option of a letter grade or credit/no credit.

6117	LEC	MHG12	STAFF	3.40	3.0	S	0800A-1105P	25
Above class meets at the Morgan Hill Community site								

Sect. Type Room Instructor Hrs. Units Days Begin-End Footnotes

**GBUS 80 Business Law**

**Advisory:** Eligible for English 250 and English 260.

**Transferable:** CSU; UC; CAN: BUS 12

Introduction to the law applicable to business institutions and their operations; social forces and their effect upon the development of law; sources of law, agencies for enforcement, and court procedure and administration agencies. Substantive law, that law which includes rights and duties, will include contracts, agency employment relationships, torts and crimes. This course has the option of a letter grade or credit/no credit.

6118	LEC	CH102	BANKS S	3.40	3.0	M	0630P-0940P	
------	-----	-------	---------	------	-----	---	-------------	--

**BUSINESS OFFICE TECHNOLOGY**

**BOT 112 Business Computations with Machines**

**Advisory:** Eligible for Mathematics 402.

**Transferable:** CSU

Self-paced course in the operation of the electronic printing calculator. This course provides theory and practice in business applications with emphasis on mathematical problem solving. This course has the option of a letter grade or credit/no credit.

4151	LAB	BU110	GAFFNEY S	1.70	.5	DHR	0000-0000	7 9
------	-----	-------	-----------	------	----	-----	-----------	-----

**BOT 180 Medical Terminology for the Office**

**Advisory:** Eligible for English 250 and English 260.

**Transferable:** CSU

This course introduces fundamentals of medical word building used in the health profession (prefixes, word roots, suffixes and abbreviations) as well as review of body systems, with emphasis on analysis, definition, spelling and pronunciation. This course had the option of a letter grade or credit/no credit.

6031	LEC	BU120	KNAPP D	3.40	3.0	Th	0600P-0910P	96
------	-----	-------	---------	------	-----	----	-------------	----

**BOT 181 Medical Billing - MediSoft**

**Advisory:** Eligible for English 250. Some computer experience.

**Transferable:** CSU

This course in computerized billing procedures for a medical office uses MediSoft software. Students will learn the patient billing features of this software and complete a capstone simulation giving them hands-on realistic medical front office practice. This course has the option of a letter grade or credit/no credit. May be repeated three times for credit.

6032	L/L	BU110	KNAPP D	4.40	2.0	M&1.4	0600P-0910P	35 96
------	-----	-------	---------	------	-----	-------	-------------	-------

**BOT 182 Medical Office Procedures**

**Prerequisite:** BOT 180 and CSIS 126 with credit or a grade of C or better or experience using Microsoft Word.

**Advisory:** Eligible for English 250 and Mathematics 402.

**Transferable:** CSU

This specialized course includes medical office procedures, patient record management, coding/billing for private/government health insurance programs, and professional ethics. May be repeated three times for credit. This course has the option of a letter grade or credit/no credit.

6033	L/L	BU110	KNAPP D	4.70	3.0	W&1.4	0600P-0910P	35 96
------	-----	-------	---------	------	-----	-------	-------------	-------

**Have you met the prerequisite?  
It's required!**

Sect. Type Room Instructor Hrs. Units Days Begin-End Footnotes

**BOT 190 Occupational Work Experience/Business Office Technology**

**Required:** Declared vocational major. Concurrent enrollment in seven or more units (including CWE units, except for summer school. For summer school enrollment in one other class is required). Minimum 2.00 G.P.A.

**Transferable:** CSU

College credit for learning experience obtained on the job in accordance with a training plan developed cooperatively between the employer, college and student. 75 hours per semester per unit or 60 hours per semester for unpaid experience. This is a credit/no credit course. May be taken for a maximum of 16 work experience units.

4152	WEX	BU125	KERR L	5.60	1.0	DHR	0000-0000	16
4153	WEX	BU125	KERR L	11.30	2.0	DHR	0000-0000	16
4154	WEX	BU125	KERR L	22.50	4.0	DHR	0000-0000	16
4155	WEX	BU125	KERR L	22.50	4.0	DHR	0000-0000	16

**Ceramics: see Art**

**CHEMISTRY**

**CHEM 1B General Chemistry**

**Prerequisite:** Chemistry 1A with a grade of C or better.

**Transferable:** CSU; UC; CSU-GE: B1, B3; IGETC: 5A; GAV-GE: B1, B3; CAN: CHEM 4, CHEM SEQ. A

This is the second semester of a year-long general chemistry course designed as a continuation of Chemistry 1A. Topics include solutions, thermodynamics, chemical kinetics, the equilibria of acids and bases, solubility systems, complex ions, electrochemistry, the chemistry of metals and nonmetals, as well as nuclear chemistry.

4183	L/L	CH109	CLARK D	7.90	5.0	MW	0945A-1110A	1
			CLARK D			F	1030A-1130A	
		CH101	CLARK D			Tu	0945A-1250P	

**CHEM 12B Organic Chemistry**

**Prerequisite:** Chemistry 12A

**Transferable:** CSU; UC; CSU-GE: B1, B3; IGETC: 5A; GAV-GE: B1, B3

This is the second semester of a year-long organic chemistry course designed as a continuation of Chemistry 12A. Topics include nomenclature, stereochemistry, mechanism, reactions, and spectroscopic studies of the various organic functional groups. Lecture and laboratory methods will focus on synthesis, isolation, purification, elucidation and identification of organic structures as well as instrumental methods and data interpretation.

4184	L/L	LS102	CLARK D	10.20	5.0	TuTh	1255P-0220P	
		CH101	CLARK D				0230P-0535P	

**CHEM 30A Elementary Chemistry**

**Advisory:** Mathematics 205; eligible for English 250 and English 260.

**Transferable:** CSU; UC; CSU-GE: B1, B3; IGETC: 5A; GAV-GE: B1, B3; CAN: CHEM 6, CHEM SEQ. B

This is a first semester chemistry course designed for majors preparing to take Chemistry 1A, nursing and allied health students as well as general education. The course will cover the principles of chemistry including properties of matter, energy, atomic theory, the Periodic Table, stoichiometry, elements and compounds, the properties of bonding molecular structure, chemical reactions, states of matter, acidic solutions and gases, as well as an introductory to organic chemistry.

6048	L/L	CH109	CLARK D	6.80	4.0	Tu	0600P-0905P	
		CH101	CLARK D			Th		

**ECON/GBUS 14 Personal Finance**

3 Units, 3 Lec



Learn to analyze your financial affairs for lifelong decision making!



- budgets
- taxes
- borrowing
- money management
- insurance
- investments
- retirement
- estate planning



**ECON 11/GBUS 11 Business Statistics**

4 UNITS

This class can be used for Math General Education requirements!



It also fulfills CSU and UC transfer requirements.



**Complete your year of Organic or General Chemistry here at Gavilan College!**

**CHEM 1B General Chemistry**

The second semester of a year-long General Chemistry course designed as a continuation of Chemistry 1A.

*Chem 1B is a prerequisite for Chem 12A (taught in the fall semester)*

**CHEM 12B Organic Chemistry**

The second semester of a year-long Organic Chemistry course designed as a continuation of Chemistry 12A.

Instructor for both courses: Dr. Dale Clark

These courses satisfy Science major prerequisites and the Physical Science requirement for transfer to both The California State University and the University of California Systems.

Sect. Type Room Instructor Hrs. Units Days Begin-End Footnotes

## CHEM 30B Elementary Organic and Biochemistry

**Prerequisite:** Chemistry 30A with a grade of C or better.

**Transferable:** CSU; UC; CSU-GE: B1, B3; IGETC: 5A; GAV-GE: B1, B3; CAN: CHEM 8, CHEM SEQ. B

This is the second semester of a year-long elementary chemistry course designed as a continuation of Chemistry 30A. It is designed for science majors, nursing and allied health students. The course will cover the principles of organic and biochemistry including hydrocarbons, alcohols, aldehydes and ketones, carboxylic acids, amines and amides, carbohydrates, lipids, proteins and their functions in physiological systems, as well as organic chemical reactions.

4185	L/L	LS103 CH101	CLARK D CLARK D	6.80	4.0	MW Th	0810A-0935A 0945A-1250P	1
------	-----	----------------	--------------------	------	-----	----------	----------------------------	---

## CHILD DEVELOPMENT

### CD 1 Principles and Philosophies of Early Childhood Education

**Advisory:** Eligible for English 250 and English 260.

**Transferable:** CSU

An overview of current educational theories and research, as well as an historical perspective on the development of early childhood education. Observations in schools are to be arranged.

6035	LEC	MHG10	SEGAL M	3.40	3.0	M	0630P-0940P
Above class meets at Morgan Hill Community site							

6041	LEC	MHG11	SHARPE E	3.40	3.0	Tu	0600P-0910P	34
Above class meets at Morgan Hill Community site. Esta sección sera enseñada en Español.								

### CD 2 Early Child Development

**Advisory:** Eligible for English 250 and English 260; transfer students consult with advisor.

**Transferable:** CSU; UC; CSU-GE: D9, E, ; IGETC: 4I; GAV-GE: D2

A systematic study of the child from prenatal life through the preschool years. The course integrates the basic concepts of physical, cognitive and psychosocial development at each major stage of life during this period. This course is also listed as PSYC 2. This course has the option of a letter grade or credit/no credit.

#### LEARNING COMMUNITY SECTIONS:

4898	LEC	LS104	CLABAUGH D	3.40	3.0	TuTh	1120A-1245P	25 36
This class is part of a Learning Community. Students enrolled must also enroll in ENGL 250, section 4360. See ad on following page.								

4900	LEC	LS104	CLABAUGH D	3.40	3.0	TuTh	1120A-1245P	25 36
This class is part of a Learning Community. Students enrolled must also enroll in ENGL 250, section 4361. See ad on following page.								

#### OTHER SECTION:

4157	LEC	LS104	CLABAUGH D	3.40	3.0	TuTh	1120A-1245P	25
------	-----	-------	------------	------	-----	------	-------------	----

### CD 3 Child Growth and Development During the School Years

**Advisory:** Eligible for English 250 and English 260; Child Development 2; transfer students consult with advisor.

**Transferable:** CSU; UC; CSU-GE: D9, E, ; IGETC: 4I; GAV-GE: D2

Continuation of the study of the principles of child development with emphasis on children from six years through adolescence. Includes developmental theories and topics relevant to these ages. This course is also listed as PSYC 3. This course has the option of a letter grade or credit/no credit.

4158	LEC	MHG4	SEGAL M	3.40	3.0	MW	1120A-1245P	25
Above class meets at Morgan Hill Community site								

6036	LEC	HOL2	BROWN R	3.40	3.0	M	0600P-0910P	25
Above class meets at the Hollister Briggs site								

Sect. Type Room Instructor Hrs. Units Days Begin-End Footnotes

### CD 4 Observing and Assessing Children

**Advisory:** Eligible for English 250 and English 260 and completion of CD2.

**Transferable:** CSU

Provides training in a variety of naturalistic and formal observation techniques, and discusses the use of standardized testing in children. Students learn to use formal observation tools, make a case study portfolio and give a parent conference. Observing children in classroom settings is required. This course has the option of a letter grade or credit/no credit.

6037	LEC	CH102	MUSCARI D	3.40	3.0	M	0600P-0910P
------	-----	-------	-----------	------	-----	---	-------------

### CD 5 Child, Family, and Community

**Advisory:** Eligible for English 250 and English 260.

**Transferable:** CSU

Patterns of child-rearing in contemporary society. Interaction of family, school and community. Significance of personal and social values in family life and community action. Individual and social resources for family life including health, welfare and improving child development.

4159	LEC	MHG4	SEGAL M	3.40	3.0	MW	0945A-1110A
Above class meets at Morgan Hill Community site							

6522	LEC	MHG11	SHARPE E	3.40	3.0	S	0900A-0300P	34 61
Above class meets at Morgan Hill Community site. Esta sección sera enseñada en Español.								

### CD 6 Games and Rhythms for Children

**Advisory:** Eligible for English 250 and English 260.

**Transferable:** CSU

Nature, function and organization of physical activities for the preschool and elementary school age child. Emphasis is given to the understanding of psychomotor development and spatial awareness. Designed for those planning to work with children. Also listed as Physical Education 6. This course has the option of a letter grade or credit/no credit.

4160	LEC	APE120	DODD S	3.40	3.0	TuTh	0810A-0925A
------	-----	--------	--------	------	-----	------	-------------

### CD 9 Child Health, Nutrition and Safety

**Advisory:** Eligible for English 250 and English 260.

**Transferable:** CSU

Health, Safety and Nutrition promotion in young children is studied. Course covers illness and accident prevention, quality food programs and community resources for health, safety and nutrition. Students will learn to promote making healthier choices by teaching hygiene, safety practices and nutritious food choices. Poison prevention, fire and earthquake safety and emergency preparedness is covered. Students learn to design lesson plans to teach children and their parents to make healthy, safe and nutritious choices. This course has the option of a letter grade or credit/no credit.

6038	LEC	HOL5	ALONZO S	3.40	3.0	Tu	0600P-0910P
Above class meets at the Hollister Briggs site							

### CD 10 Children with Special Needs

**Advisory:** Eligible for English 250 and English 260. Completion of CD 2.

**Transferable:** CSU

An introductory course in special education, which includes a survey of special needs such as learning disabilities, emotional disturbances, developmental delays, physical limitations, cognitive differences, and giftedness. Students will study the history of special education and legislation in the USA, ethical assessment and family-based intervention techniques, diversity and family issues, advocacy for special needs children, and the use of technology in special education environments. This course has the option of a letter grade or credit/no credit.

4161	LEC	CD127	CLABAUGH D	3.40	3.0	TuTh	0945A-1110A
------	-----	-------	------------	------	-----	------	-------------

Sect. Type Room Instructor Hrs. Units Days Begin-End Footnotes

**CD 11C Supervision of Adults: The Mentor Teacher**

**Advisory:** Prefer that students meet the requirements for the State Child Development Teacher Permit or completion of a college-level course of study in child development or early childhood education, or equivalent, or permission of instructor.  
**Transferable:** CSU

A study of the methods and principles of supervising adults in early childhood settings. Emphasis is on the role of the experienced classroom teacher who functions as a "mentor/supervisor" to teachers, aides, and other adults. This course meets the requirements for the State Child Development Permit Matrix: "2 unit adult supervision class" and the Mentor Teacher Program. Lectures, discussions, in class and out of class activities, role-play simulations, readings, individual and group assignments as well as videos and guest presenters will be used.

6039	LEC	MHG4	MALASPINA B	8.00	2.0	S	0800A-0400P	11 58	
02/24/07 - 03/31/07 Above class meets at Morgan Hill Community site									

**CD 12 Computer Education for Teachers**

**Advisory:** CSIS 122 Computer Keyboarding, or equivalent; English 250 with a grade of C or better.  
**Transferable:** CSU

The history, uses and development of computers in education. Basic computer skills and terminology will be taught in the context of teacher education. Students who successfully complete this course will understand general and specific skills and knowledge required to meet the Technology Standard for Multiple and Single Subject Credential Candidates. This course has the option of a letter grade or credit/no credit. This course is also listed as CSIS 9.

6040	LEC	LI171	CLABAUGH D	3.40	3.0	Th	0600P-0910P	25	
------	-----	-------	------------	------	-----	----	-------------	----	--

**CD 13 Infant and Toddler Development and Care**

**Advisory:** Eligible for English 250 and English 260. Child Development 2.  
**Transferable:** CSU

Students will study the developmental stages of growth specific to infants and toddlers and learn how to foster positive techniques for nurturing infants and toddlers in group settings. Students will study the RIE philosophy and learn how to observe children in child care and home day care settings. This course has the option of a letter grade or credit/no credit.

6042	LEC	HOL5	STAFF	3.40	3.0	Th	0600P-0910P	34	
Above class meets at the Hollister Briggs site. Esta sección sera enseñada en Español.									

**CD 22 Field Work and Service**

**Required:** Learning contracts must be filled out and signed by the student and the supervising instructor.  
**Transferable:** CSU

Supervised field work within the college and with local agencies. Students serve in useful group activities in leadership roles prescribed for them by faculty or community agencies. A maximum of six units may be completed.

4162	FEX	CD131	SEGAL M	3.40	1.0	TBA	0000-0000	21 73	
------	-----	-------	---------	------	-----	-----	-----------	-------	--

**CD 23 Independent Study**

**Required:** The study outline prepared by the student and the instructor must be approved by the department and the dean.  
**Transferable:** CSU

Designed to afford selected students specialized opportunities for exploring areas at the independent study level. The courses may involve extensive library work, research in the community, or special projects. May be repeated three times or until six units of credit are accrued. This course has the option of a letter grade or credit/no credit.

4163	IND	CD131	SEGAL M	3.40	1.0	TBA	0000-0000	22 73	
4164	IND	CD131	SEGAL M	6.40	2.0	DHR	0000-0000		

**CD 25A Art Methods**

**Transferable:** CSU; CSU-GE: C1; GAV-GE: C1

Art methods and learning theory for those planning to work with preschool, elementary and secondary students. Includes art therapy as well as gifted and special learner projects. Two dimensional work in printing, painting, drawing, collage. Also listed as ART 25A.

6521	L/L	HOL1	MCGINNIS R	4.50	3.0	F&2.3	0400P-0815P	25	
Above class meets at the Hollister Briggs site									



**Playing With Learning:  
Understanding How Kids Grow**

This learning community will strengthen students' reading and writing skills while studying children's development.

Students must enroll in both courses.

**ENGL 250 Practical Writing**

4360	L/L	HU102	CROOK E	4.40	3.0	MW	1255P-0220P	1 18 36	
		LI171	CROOK E			Tu	1255P-0155P		

**CD 2 Early Child Development**

4898	LEC	LS104	CLABAUGH D	3.40	3.0	TuTh	1120A-1245P	25	
------	-----	-------	------------	------	-----	------	-------------	----	--

\_\_\_\_\_ or \_\_\_\_\_

**ENGL 250 Practical Writing**

4903	L/L	HU102	CROOK E	4.40	3.0	MW	1255P-0220P	1 18 36	
		LI171	CROOK E			Tu	1255P-0155P		

**PSYC 2 Early Child Development**

4899	LEC	LS104	CLABAUGH D	3.40	3.0	TuTh	1120A-1245P	25	
------	-----	-------	------------	------	-----	------	-------------	----	--

\_\_\_\_\_ or \_\_\_\_\_

**ENGL 250 Practical Writing**

4361	L/L	HU102	CROOK E	4.40	3.0	MW	1255P-0220P	1 18 36	
		LI171	CROOK E			Th	1255P-0155P		

**CD 2 Early Child Development**

4900	LEC	LS104	CLABAUGH D	3.40	3.0	TuTh	1120A-1245P	25	
------	-----	-------	------------	------	-----	------	-------------	----	--

\_\_\_\_\_ or \_\_\_\_\_

**ENGL 250 Practical Writing**

4904	L/L	HU102	CROOK E	4.40	3.0	MW	1255P-0220P	1 18 36	
		LI171	CROOK E			Th	1255P-0155P		

**PSYC 2 Early Child Development**

4901	LEC	LS104	CLABAUGH D	3.40	3.0	TuTh	1120A-1245	25	
------	-----	-------	------------	------	-----	------	------------	----	--

*Rho Alpha Mu*  
**HONOR SOCIETY**



Gain eligibility for special scholarships and awards!

Must have a GPA of at least 3.0 for twelve units.

Meet other honors students!

Incoming freshmen with GPA of a least 3.5 in HS

Serve the community!

(408) 846-4947

**Footnotes contain valuable information pertaining to your class selection. Footnotes follow class listings.**



Sect. Type Room Instructor Hrs. Units Days Begin-End Footnotes

**CD 25B Art Methods**

Transferable: CSU; GAV-GE: C1

Art methods, creativity and learning theory for those planning to work with preschool, elementary, and secondary school students. Includes art therapy as well as gifted and special learner projects. Three dimensional work in sculpture, bas relief, mobiles, paper mache', plaster, and various 3-D materials. Also listed as ART 25B.

6044	L/L	HOL1	MCGINNIS R	4.50	3.0	F&2.3	0400P-0815P	25
Above class meets at the Hollister Briggs site								

**CD 28B Developmental Learning Activities for Family Child Care & Foster Care**

Transferable: CSU

A practical curriculum development course for child care providers. The course includes a brief overview of children's learning processes and practical activities. Students will study appropriate curriculum for infants, toddlers, preschool, and school-age children in all areas of development. Students will learn how to set up a family child care environment. This course has the option of a letter grade or credit/no credit

6045	LEC	CD127	ALONZO S	3.00	1.0	F	0600P-0850P	11
						S	0900A-0400P	
04/27/07 - 05/05/07								

**CD 30B Teaching Practices and Techniques II**

Advisory: Child Development 30A. Concurrent enrollment in CD 190.

Transferable: CSU

Continuation of CD 30A with emphasis on assessment, conferencing and planning skills. Completion of 30A and 30B fulfills State Child Development Permit requirements, and satisfies the associate degree student teaching requirements.

6046	LEC	CH102	SEGAL M	3.40	3.0	W	0600P-0910P	
------	-----	-------	---------	------	-----	---	-------------	--

**CD 160 Child Care First Aid and CPR**

Transferable: CSU

First aid training to prepare child care professionals to meet the needs of emergencies when medical assistance is delayed. Includes information on the prevention of childhood injuries and the prevention of communicable diseases including HIV/AIDS and the use of Universal Precautions. (Satisfies the California Community Care Licensing requirement for 15 hours of specialized health and safety training.) This is a credit/no credit course. May be repeated three times for credit.

6047	LEC	CD127	ALONZO S	3.00	1.0	F	0600P-0910P	11 57
						S	0900A-0400P	
02/02/07 - 02/09/07								

**CD 190 Occupational Work Experience/Child Development**

Required: Declared vocational major. Concurrent enrollment in seven or more units (including CWE units, except for summer school. For summer school, enrollment in one other class is required). Minimum 2.00 G.P.A.

Transferable: CSU

College credit for learning experience obtained on the job in accordance with a training plan developed cooperatively between the employer, college and student. 75 hours per semester per unit or 60 hours per semester for unpaid experience. This is a credit/no credit course. May be taken for a maximum of 16 work experience units.

4167	WEX	CD131	SEGAL M	5.60	1.0	TBA	0000-0000	14
4168	WEX	CD131	SEGAL M	11.30	2.0	TBA	0000-0000	14
4169	WEX	CD131	SEGAL M	16.90	3.0	TBA	0000-0000	14
4170	WEX	CD131	SEGAL M	22.50	4.0	TBA	0000-0000	14

**For on-campus child care**  
contact the Child Development Center at (408) 848-4815

Sect. Type Room Instructor Hrs. Units Days Begin-End Footnotes

**COMMUNICATIONS**

Gavilan Community College is now offering a Certificate of Achievement in Communication Studies to students who successfully complete 12 units of communication studies coursework. This certificate will inform future employers, college admissions offices and professional institutions that you have received specialized training in communication skills. This certificate can accompany any degree and enhance your qualifications for the job or university you desire.

Take this opportunity to learn skills that will increase your understanding of yourself, your relationships and your ability to communicate with other people. The Communication Studies Department welcomes you and encourages you to pursue this certificate and empower yourself.

**CMUN 1A Introduction to Public Speaking**

Advisory: Eligible for English 250 and English 260.

Transferable: CSU; UC; CSU-GE: A1; IGETC: 1C; GAV-GE: A1; CAN: SPCH 4

Basic principles of effective human communication and their function in contemporary public settings; emphasis is on the speech to inform, with special consideration given to fundamental communication skills, including organization, reasoning, explanation and listening.

4186	LEC	TH127	GIACALONE S	3.40	3.0	MW	0810A-0935A	
4187	LEC	HOL1	RISTRIM B	3.40	3.0	MW	0810A-0935A	
Above class meets at the Hollister Briggs site								
4188	LEC	MHG3	EHRLE D	3.40	3.0	TuTh	0945A-1110A	
Above class meets at Morgan Hill Community site								
4189	LEC	LS104	ANDRADE A	3.40	3.0	M	1120A-1245P	
		LI171				W	1120A-1245P	
4190	LEC	TH127	BESSION D	3.40	3.0	TuTh	1120A-1245P	
4191	LEC	TH127	BESSION D	3.40	3.0	TuTh	1255P-0220P	43
4192	LEC	TH127	PAULSON M	3.40	3.0	TuTh	0230P-0355P	
4883	LEC	LOHS	STAFF	3.40	3.0	M	0330P-0640P	69
This class is part of the High Step program. It will be offered at Live Oak High School. Check online footnote for location. This class is open to all students. For more information, see a Gavilan counselor.								

**CMUN 2 Oral Reading**

Advisory: Eligible for English 250 and English 260.

Transferable: CSU; UC; CSU-GE: C1; GAV-GE: C1

An introduction to the analysis, preparation and dramatic reading of literature, including classical and contemporary prose, poetry and drama. Students will prepare, analyze and orally present and interpret great works of drama and literature for an audience. This course is also listed as THEA 4.

4193	LEC	LI144	STAFF	3.40	3.0	TuTh	0945A-1110A	25
------	-----	-------	-------	------	-----	------	-------------	----

**CMUN 4 Intercultural Communication**

Transferable: CSU; UC; CSU-GE: D3, D7; IGETC: 4G; GAV-GE: D2, F

This course will explore the dynamics of communication as it applies to people from different cultures. Course content focuses on the application of theory and research to intercultural communication contexts. Increasing the awareness and understanding of diversity, the perception process, culture, verbal and non-verbal communication and the obstacles that prevent one from becoming a competent intercultural communicator will be examined.

4194	LEC	TH127	GIACALONE S	3.40	3.0	MW	0945A-1110A	
------	-----	-------	-------------	------	-----	----	-------------	--

**CMUN 6 Introduction to Conflict Resolution**

Advisory: English 250 and English 260.

Transferable: CSU; CSU-GE: D7; GAV-GE: D2

Introduction to Conflict Resolution introduces students to conflict resolution and mediation. Integrating theory and practice, students will assess core concepts about the causes and resolution of conflict, and will practice communication skills for conflict resolution. Students will examine how ethnicity, gender, and class affect power in conflict situations. They will be able to formulate appropriate conflict resolution strategies, and will develop and practice various basic co-mediation skills. This course has the option of a letter grade or credit/no credit. This course is also listed as POLS 6, AJ 6 and PSYC 6.

4195	LEC	SS205	HALPER L	3.40	3.0	MW	0945A-1110A	25
------	-----	-------	----------	------	-----	----	-------------	----

Sect. Type Room Instructor Hrs. Units Days Begin-End Footnotes

**CMUN 8 Interpersonal Communication**

Transferable: CSU; UC; CSU-GE: A1; IGETC: 1C; GAV-GE: A1

This course studies the communication process in an interpersonal (dyadic) setting. This class will explore the ways in which we can improve our communication with others. Verbal and nonverbal messages, self-concept, cultural differences, gender differences, perception, listening and conflict management will be explored.

4196	LEC	TH127	BESSON D	3.40	3.0	MW	1255P-0220P
4197	LEC	TH127	BESSON D	3.40	3.0	M	0230P-0540P
4198	LEC	TH127	PAULSON M	3.40	3.0	TuTh	0400P-0525P

**CMUN 10 Small Group Communication**

Advisory: Eligible for English 250 and English 260.

Transferable: CSU; UC; CSU-GE: A1; IGETC: 1C; GAV-GE: A1; CAN: SPCH 10

An introductory course that develops basic individual reasoning skills, insights and experiences in information-sharing, interacting, decision-making, problem-solving, resolution of disputes and other issues central to group processes.

4199	LEC	HOL1	RISTRIM B	3.40	3.0	MW	0945A-1110A	Above class meets at the Hollister Briggs site
4200	LEC	TH127	RISTRIM B	3.40	3.0	TuTh	0945A-1110A	
4201	LEC	TH127	BESSON D	3.40	3.0	MW	1120A-1245P	
6049	LEC	MHG10	COWAN D	3.40	3.0	W	0630P-0940P	Above class meets at Morgan Hill Community site
6050	LEC	HOL1	ANDRADE A	3.40	3.0	Th	0600P-0910P	Above class meets at the Hollister Briggs site

**CMUN 11 Business Communication**

Prerequisite: English 250.

Advisory: Communication 1A or English 1A.

Transferable: CSU

This course will explore business communication contexts by examining organizational cultures, strategic vision and goal setting, leadership managerial roles, and team building communication. Emphasis is placed on analytical and organizational skills, listening, nonverbal and verbal communication, public speaking communication methodology, and domestic and international relations through use of hybrid online and classroom environment for lecture and application.

6051	LEC	TH127	WADDELLE	3.40	3.0	M	0600P-0910P	13
------	-----	-------	----------	------	-----	---	-------------	----



This HYBRID lecture/online class will be delivered partially over the internet. See the online syllabus for details. <http://www.gavilan.edu/disted/>.

**CMUN 129 Presentation Graphics - MS Powerpoint**

Advisory: CSIS 126 or word processing skills in the Windows environment.

Transferable: CSU

This introductory course in presentation graphics will use Microsoft Office's "PowerPoint" software to create a computerized presentation with text and objects. This course has the option of a letter grade or credit/no credit. May be repeated three times for credit. This course is also listed as CSIS 129.

4202	LEC	HOL3	BRYSON M	4.60	1.0	MW	0900A-1105A	11 25	04/18/07 - 05/16/07 Above class meets at the Hollister Briggs site
4879	LEC	LI120	ANDRADE A	1.0	1.0	MW	1245P-0200P	11 25	02/05/07 - 03/12/07

**Computer Art: see ART 48A/B, CSIS or Digital Media**

**A counselor's signature is required**

if you take over 17.99 units (spring/fall) or over 5.99 units (summer). You do not need a counselor's signature to register for a class with a prerequisite that was successfully completed at Gavilan.

**Footnotes contain valuable information pertaining to your class selection. Footnotes follow class listings.**

**CMUN 129**

**Presentation Graphics - MS Powerpoint**

1 unit - 6 week course

Also listed as CSIS 129



Come on a voyage of self-discovery and become more culturally fluent.

Take...

**CMUN 4**

**Intercultural Communication**



- ☞ Learn about people from different cultures.
- ☞ Increase your awareness and understanding of diversity.
- ☞ Study verbal and nonverbal communication.
- ☞ Become a competent communicator in an intercultural society.

**CMUN 11 Business Communication**

Examine organizational cultures, strategic vision and goal setting, leadership managerial roles and team building communication.



Offered as a HYBRID lecture/online class

**Earn a Certificate of Achievement in Communication Studies**

Complete 12 units. Classes applicable:

- CMUN 1A
- CMUN 2
- CMUN 4
- CMUN 5
- CMUN 8
- CMUN 10
- CMUN 11
- CMUN 129

You're only four classes away. Get started today!



Contact Denise Besson-Silvia at 408-848-4831 for further information.

**CMUN 8 Interpersonal Communication**

Offering three sections to meet demand!

Study the ways in which we can improve our communication with others. Verbal and nonverbal messages, self-concept, cultural differences, gender differences, perception, listening and conflict management are explored.



Fulfills CSU and UC Oral Communication transfer requirements



The people of old had their own signals. Here's one that has meant "Attention" through all ages.

Sect. Type Room Instructor Hrs. Units Days Begin-End Footnotes

## COMPUTER GRAPHICS AND DESIGN

### CGD 1 Industrial Sketching and Problem Solving

**Advisory:** Eligible for English 250, English 260 and Mathematics 205.  
**Transferable:** CSU

Graphical problem solving techniques used by professional designers in various fields of application using both traditional freehand and the computer. Emphasis is on developing the mental ability to visualize objects/shapes and their manipulation. This is an open entry exit supervised class. Students may concurrently enroll in CGD 110 or GCD 2L. May be repeated three times for a total of 8 units.

4171 L/L LI126 PEACOCK R 4.40 2.0 Tu&2 0915A-1040P 73 99

### CGD 2 2D/3D Technical Computer Graphics I

**Advisory:** LIB 3 and MATH 404G.  
**Transferable:** CSU

Introduction and foundation to 2D and 3D visualization and manipulation using modeling, rendering, and animation processes. Emphasis is on individual students developing a personal style of problem solving and designing for a variety of design fields. Students work on cooperative group projects or individual assignments. This is an open entry/exit class and may be repeated once. May be repeated once for credit. This course has the option of a letter grade or credit/no credit.

4172 L/L LI126 PEACOCK R 9.10 4.0 MW&5 0915A-1040A 73 99

4173 L/L LI126 PEACOCK R 9.10 4.0 TuTh&5 0915A-1040A 73 99

### CGD 4 2D/3D Technical Computer Graphics II

**Advisory:** Completion of CGD 2 with a grade of C or better.  
**Transferable:** CSU

Intermediate to complex 2D/3D modeling of geometric objects including working drawings, rendering and animation activities. This class allows personal student development in imagination and inventive problem solving that can be related to various creative design fields. Students work in individual and cooperative group projects. This is an open entry/exit course.

4174 L/L LI126 PEACOCK R 10.10 4.0 MW&6 0115P-0330P 73 99

### CGD 6 Advanced Technical Computer Graphics

**Advisory:** Eligible for English 250, 260 and Mathematics 233.  
**Transferable:** CSU

Computer design in precision manufacturing. Applied geometry, mathematics for layout, and tolerancing. Advanced design processes and documentation for the designer. Students may concurrently enroll in CGD 110. An open entry/exit course.

4175 L/L LI126 PEACOCK R 9.10 4.0 MW&5 0115P-0330P 73 99

### CGD 8 Advanced Computer Graphics for Design Application I

**Advisory:** Eligible for English 250, 260 and Mathematics 233.  
**Transferable:** CSU

Application of computer graphics to specific technical design and graphic communication projects tailored to the student's major study area. An open entry/exit supervised class. This allows students an individual or a cooperative learning environment on selected projects. Students may concurrently enroll in CGD 110.

4176 L/L LI126 PEACOCK R 9.10 4.0 MW&5 1045A-1220P 73 99

## Less Grade Stress!!

Most CSIS and Business classes can be taken for letter grade or CR/NC. See Credit/No Credit Option Grading.

Sect. Type Room Instructor Hrs. Units Days Begin-End Footnotes

### CGD 9 Advanced Computer Graphics for Design Application II

**Advisory:** Satisfactory score on the English placement exam or a grade C or better in English 250, completion of Mathematics 233 or satisfactory Mathematics placement. Completion of CGD 2 and CGD 8 with a grade of C or better.  
**Transferable:** CSU

A course designed to the student's major study area using computer graphics. The student can combine various content areas for a specific application. An open entry/exit supervised class which allows for a shortened semester schedule with a corresponding increase in lab time. The student is allowed an individual or a cooperative environment on selected projects. Students may concurrently enroll in CGD 110 and CGD 4.

4177 L/L LI126 PEACOCK R 9.10 4.0 TuTh&5 1045A-1220P 31 73 99

### CGD 110 Computer Graphics Lab

**Advisory:** Concurrent enrollment in corresponding computer graphic and design classes.  
**Transferable:** CSU

Structured for students concurrently enrolled in computer graphics and art classes. Provides supervised practice and individualized computer assisted learning on software applications and techniques commonly found in the computer graphic design field. This is an open entry/exit class and may be repeated three times. This course has the option of a letter grade or credit/no credit.

4178 L/L LI126 PEACOCK R 3.40 1.0 TBA 0000-0000 31 73 99

4179 L/L LI126 PEACOCK R 6.80 2.0 TBA 0000-0000 31 73 99

4180 L/L LI126 PEACOCK R 10.10 3.0 TBA 0000-0000 31 73 99

4181 L/L LI126 PEACOCK R 13.50 4.0 TBA 0000-0000 31 73 99

### CGD 160 Technical Manual Desktop Publishing/Graphics

**Advisory:** Eligible for English 250, 260 and Mathematics 233. Familiarity with word processing, keyboarding, and DOS file management.  
**Transferable:** CSU

Combines graphic arts, CAD, and desktop software. Topics include graphic design, drawing, text managing, typography, image scanning, clip art, and technical document publication. This is an open entry/exit class.

4182 L/L LI126 PEACOCK R 9.10 4.0 MW&5 0115P-0330P

## COMPUTER SCIENCE & INFORMATION SYSTEMS

### CSIS 1 Computer Literacy - MS Office

**Advisory:** Eligible for English 250 and English 260; completion of CSIS 122.  
**Transferable:** CSU; UC; GAV-GE: E2; CAN: CSCI 2

An introduction to terminology, design, operation for the novice user. Student will gain experience using the Internet for searches and email. They will complete projects using various software including word processing, spreadsheets, database, presentation graphics, and integration. This course has the option of a letter grade or credit/no credit.

4218 LEC HOL3 BRYSON M 4.60 2.0 MW 0900A-1105A 11  
02/05/07 - 04/04/07 Above class meets at the Hollister Briggs site

4219 LEC BU120 MILLER K 4.60 2.0 TuTh 0900A-1105A 11  
02/01/07 - 03/22/07

4220 LEC BU120 MILLER K 4.60 2.0 TuTh 0900A-1105A 11  
03/27/07 - 05/22/07

6053 LEC HOL3 THOMPSON F 4.60 2.0 Tu 0600P-0950P 11  
02/06/07 - 04/03/07 Above class meets at the Hollister Briggs site

6054 LEC BU111 VENABLE E 4.60 2.0 W 0600P-0950P 11  
03/14/07 - 05/16/07



Sect. Type Room Instructor Hrs. Units Days Begin-End Footnotes

Sect. Type Room Instructor Hrs. Units Days Begin-End Footnotes

## CSIS 2 Computers in Business - MS Office

**Advisory:** Eligible for Mathematics 233, English 260 and English 250, and CSIS 122  
**Transferable:** CSU; GAV-GE: E2; CAN: BUS 6

Introduction to computerized business data processing, information management systems, computer hardware, office automation, telecommunications, computer languages, systems analysis and design; hands on experience with common business software packages including word processing, spreadsheets, data base management, presentation graphics as well as systems software and Internet applications. This course has the option of a letter grade or credit/no credit.

4221	L/L	BU111	VENABLE E	1.00	4.0	Tu&5.8	0945A-1110A	13
	This HYBRID lecture/online class will be delivered partially over the internet. See the online syllabus for details. <a href="http://www.gavilan.edu/disted/">http://www.gavilan.edu/disted/</a> .							
4889	L/L	BU111	VENABLE E	1.00	4.0	F&5.8	0945A-1110A	13
	This HYBRID lecture/online class will be delivered partially over the internet. See the online syllabus for details. <a href="http://www.gavilan.edu/disted/">http://www.gavilan.edu/disted/</a> .							

## CSIS 2L Computers in Business Lab - MS Office

**Transferable:** CSU

Computer Lab emphasizing business application in Microsoft Word, Excel, Access, Power Point and Integration. Internet searches are included. This course has the option of a letter grade or credit/no credit. Since supervised repetition and practice enhance skills/proficiencies, This course may be repeated once for credit.

4222	LAB	BU111	BRYSON M	3.40	1.0	Tu&2	0945A-1110A	35
4223	LAB	BU111	BRYSON M	3.40	1.0	F&2	0945A-1110A	35
6055	LAB	BU110	GAFFNEY S	3.40	1.0	Tu	0600P-0950P	

## CSIS 5 C++ Scientific Programming

**Prerequisite:** Mathematics 1A  
**Advisory:** Completion of CSIS 10.  
**Transferable:** CSU; UC; CAN: CSCI 4

An introduction to computer problem solving and programming using the C++ language for science and engineering majors. Students will write programs for a variety of scientific and mathematical applications. This course has the option of a letter grade or credit/no credit.

4224	ONLINE	VANTASSEL D	5.70	3.0	DHR	0000-0000	38
	This online class will be delivered entirely over the internet. After enrolling, start the class by going to <a href="http://www.gavilan.edu/disted/">http://www.gavilan.edu/disted/</a> , click on your class link, and email the instructor at <a href="mailto:dvantassel@gavilan.edu">dvantassel@gavilan.edu</a> . Students who have not begun the class or contacted the instructor by 5 pm on Monday, February 5 will be dropped from the class.						

6056	L/L	BU111	VANTASSEL D	5.70	3.0	Tu	0600P-0950P	
------	-----	-------	-------------	------	-----	----	-------------	--

## CSIS 6 Web Page Authoring I

**Advisory:** CSIS 1 or CSIS 2 or CSIS 3/LIB 3 advised.  
**Transferable:** CSU; GAV-GE: E2

An introduction to using Hypertext Mark-Up Language (HTML) and Extensible HTML (XHTML) to create web pages which can be uploaded and displayed on the World Wide Web. Students will use HTML/XHTML to create web pages with text in various sizes and colors, links to other sites, background color or patterns, graphics, tables and mailto links. Principles of design and color as they apply to screen presentations will be included. This course has the option of a letter grade or credit/no credit. May be repeated three times for credit. Also listed as LIB 6 and DM 6.

4225	ONLINE	HOWELL J	4.60	2.0	DHR	0000-0000	11 25 38
	01/31/07 - 03/24/07 This online class will be delivered entirely over the internet. After enrolling, start the class by going to <a href="http://www.gavilan.edu/disted/">http://www.gavilan.edu/disted/</a> , click on your class link, and email the instructor at <a href="mailto:jhowell@gavilan.edu">jhowell@gavilan.edu</a> . Students who have not begun the class or contacted the instructor by 5 pm on Monday, February 5 will be dropped from the class.						

4226	ONLINE	VENABLE E	4.60	2.0	DHR	0000-0000	11 25 38
	03/26/07 - 05/21/07 This online class will be delivered entirely over the internet. After enrolling, start the class by going to <a href="http://www.gavilan.edu/disted/">http://www.gavilan.edu/disted/</a> , click on your class link, and email the instructor at <a href="mailto:smeader@gavilan.edu">smeader@gavilan.edu</a> . Students who have not begun the class or contacted the instructor by 5 pm on the third day of the class, will be dropped from the class.						

## CSIS 8 Introduction to the Internet

**Advisory:** CSIS 124  
**Transferable:** CSU; GAV-GE: E2

This course will provide students the opportunity to learn to use the Internet and the World Wide Web. Topics to be covered include history of the Internet and development of the WWW, web browsers, search engines, tools to develop web pages, how to get connected and local Internet providers. This is a credit/no credit course. May be repeated three times for credit.

4227	LEC	MHG8	CONREY J	3.00	1.0	TuTh	1120A-1240P	11
				05/03/07 - 05/22/07 Above class meets at the Morgan Hill Community site				
4228	ONLINE	VENABLE E	2.50	1.0	DHR	0000-0000	11 38	
	03/05/07 - 04/27/07 This online class will be delivered entirely over the internet. After enrolling, start the class by going to <a href="http://www.gavilan.edu/disted/">http://www.gavilan.edu/disted/</a> , click on your class link, and email the instructor at <a href="mailto:evenable@gavilan.edu">evenable@gavilan.edu</a> . Students who have not begun the class or contacted the instructor by 5 pm on Monday, March 8 will be dropped from the class.							

## CSIS 9 Computer Education for Teachers

**Advisory:** CSIS 122 Computer Keyboarding, or equivalent; English 250 with a grade of C or better.  
**Transferable:** CSU

The history, uses and development of computers in education. Basic computer skills and terminology will be taught in context of teacher education. Students who successfully complete this course will understand general and specific skills and knowledge required to meet the Technology Standard for Multiple and Single Subject Credential Candidates. This course has the option of a letter grade or credit/no credit. This course is also listed as CD 12.

6057	LEC	LI171	CLABAUGH D	3.40	3.0	Th	0600P-0910P	25
------	-----	-------	------------	------	-----	----	-------------	----

## CSIS 10 BASIC Programming

**Advisory:** CSIS 1 or CSIS 2 or equivalent experience.  
**Transferable:** CSU; UC

This course is an introduction to programming using BASIC. No previous programming background is assumed. This is a good class for those new to programming and recommended for non-programmers that want to take other programming classes. This course has the option of a letter grade or credit/no credit.

4229		BU118	ROBINSON V	4.30	2.0	F&2	0945A-1145A	11
				03/30/07 - 05/18/07				

## CSIS 12 Assembly Language Programming

**Corequisite:** CSIS 12L Assembly Language Programming Lab  
**Advisory:** CSIS 45 (C++ Programming) or programming experience. Math 233 (Intermediate Algebra)  
**Transferable:** CSU; UC

Fundamentals of assembly language programming concepts and techniques. Topics include internal representation of data, arithmetic operations, logic statements, and general assembly language commands. Introduce low level language architecture including assemblers, linkage editors, and loaders. This course has the option of a letter grade or credit/no credit.

4230	ONLINE	VANTASSEL D	3.40	3.0	DHR	0000-0000	38
	This online class will be delivered entirely over the internet. After enrolling, start the class by going to <a href="http://www.gavilan.edu/disted/">http://www.gavilan.edu/disted/</a> , click on your class link, and email the instructor at <a href="mailto:dvantassel@gavilan.edu">dvantassel@gavilan.edu</a> . Students who have not begun the class or contacted the instructor by 5 pm on Monday, February 5 will be dropped from the class.						

6058	LEC	MHG8	VANTASSEL D	3.40	3.0	S	0900A-1200P	11
				02/10/07 - 05/19/07 Above class meets at Morgan Hill Community site				

# Campus under construction ROOM NUMBERS MAY CHANGE!

Check room numbers online before your first class.

Sect. Type Room Instructor Hrs. Units Days Begin-End Footnotes

## CSIS 12L Assembly Language Programming Lab

**Corequisite:** CSIS 12 Assembly Language Programming  
**Transferable:** CSU; UC

Supplemental practice in coursework associated with this course is provided. Concurrent enrollment in CSIS 12 is required. This is a credit/no credit course.

4890	ONLINE	VANTASSEL D	1.4	1.0	DHR	0000-0000	38
 This online class will be delivered entirely over the internet. After enrolling, start the class by going to <a href="http://www.gavilan.edu/disted/">http://www.gavilan.edu/disted/</a> , click on your class link, and email the instructor at <a href="mailto:jtarvin@gavilan.edu">jtarvin@gavilan.edu</a> . Students who have not begun the class or contacted the instructor by 5 pm on Monday, February 5 will be dropped from the class.							
6518	LAB	MHG 8	VANTASSEL D	1.4	1.0	SAT&2	1200P-0100P 11
02/10/07 05/19/07							

## CSIS 23 Independent Study

**Required:** The study outline prepared by the student and the instructor must be filed with the department and the dean.  
**Transferable:** CSU

Designed to afford selected students specialized opportunities for exploring areas at the independent study level. The courses may involve extensive library work, research in the community, or special projects. May be repeated until six units of credit are accrued. This course has the option of a letter grade or credit/no credit.

6059	IND	MHG8	VANTASSEL D	3.40	1.0	SUN&3.4	0400P-0800P 8
Above class meets at Morgan Hill Community site							

## CSIS 45 C++ Programming I

**Advisory:** CSIS 10 or equivalent. Math 205 (Elementary Algebra)  
**Transferable:** CSU; UC; GAV-GE: E2; CAN: CSCI 18

An introduction to the concepts and methods of computer programming using C++. Students will be introduced to procedural and object-oriented programming design methodology. Topics covered include variable and constant declarations, selection statements, repetition, functions and recursion, arrays, strings, pointers, and an introduction to classes and objects. This course will prepare students for the Programming II class. This course has the option of a letter grade or credit/no credit.

4231	ONLINE	VANTASSEL D	6.80	4.0	DHR	0000-0000	38
 This online class will be delivered entirely over the internet. After enrolling, start the class by going to <a href="http://www.gavilan.edu/disted/">http://www.gavilan.edu/disted/</a> , click on your class link, and email the instructor at <a href="mailto:dvantassel@gavilan.edu">dvantassel@gavilan.edu</a> . Students who have not begun the class or contacted the instructor by 5 pm on Monday, February 5 will be dropped from the class.							
6060	L/L	BU111	VANTASSEL D	6.80	4.0	Tu	0600P-0950P

## CSIS 48 UNIX/Linux Operating System

**Advisory:** CSIS 1 or CSIS 2 or equivalent computer experience.  
**Transferable:** CSU; UC

This course will provide the basics of the UNIX/Linux operating system, including the history and the use of UNIX/Linux with hands-on experience using commands and files. Topics to be covered include basic UNIX/Linux commands, text editing, files and directories, electronic mail, pipes and filters, and shell programming. This course has the option of a letter grade or credit/no credit.

4232	ONLINE	VANTASSEL D	6.80	4.0	DHR	0000-0000	38
 This online class will be delivered entirely over the internet. After enrolling, start the class by going to <a href="http://www.gavilan.edu/disted/">http://www.gavilan.edu/disted/</a> , click on your class link, and email the instructor at <a href="mailto:dvantassel@gavilan.edu">dvantassel@gavilan.edu</a> . Students who have not begun the class or contacted the instructor by 5 pm on Monday, February 5 will be dropped from the class.							
6061	L/L	MHG8	VANTASSEL D	6.80	4.0	M&2	0600P-0950P
Above class meets at Morgan Hill Community site							

Sect. Type Room Instructor Hrs. Units Days Begin-End Footnotes

## CSIS 51 Visual Basic .NET Programming

**Advisory:** CSIS 10 or equivalent.  
**Transferable:** CSU; UC; GAV-GE: E2

An introduction to the GUI software applications using Microsoft Visual Basic .NET. This course will give students the opportunity to learn how to create applications using Visual Basic programming in the .NET framework. This course will show the students to use forms, boxes, buttons, labels, menus, scroll bars, and drawing objects. This course will show the students how to develop professional looking and deployable Visual Basic .NET applications. This course has the option of a letter grade or credit/no credit. This course may be repeated three times for credit.

4233	ONLINE	TARVIN J	6.80	4.0	DHR	0000-0000	38
 This online class will be delivered entirely over the internet. After enrolling, start the class by going to <a href="http://www.gavilan.edu/disted/">http://www.gavilan.edu/disted/</a> , click on your class link, and email the instructor at <a href="mailto:jtarvin@gavilan.edu">jtarvin@gavilan.edu</a> . Students who have not begun the class or contacted the instructor by 5 pm on Monday, February 5 will be dropped from the class.							
6062	L/L	MHG5	TARVIN J	6.80	4.0	Tu&2	0600P-0950P
Above class meets at Morgan Hill Community site							

## CSIS 54 Perl Programming

**Corequisite:** CSIS 54L Perl Programming Lab  
**Advisory:** CSIS 45 C++ Programming or equivalent programming experience.  
**Transferable:** CSU; UC

Introduction to the interpreted language called PERL, the Practical Extraction and Report Language. Writing of programs that perform various tasks, including text, file and process manipulation. Semantics and syntax of the Perl language, including discussion of the practical kinds of problems that Perl can solve and provides examples. This course has the option of a letter grade or credit/no credit. Concurrent enrollment in CSIS 54L is required.

4896	ONLINE	HOWELL P	3.40	3.0	DHR	0000-0000	38
 This online class will be delivered entirely over the internet. After enrolling, start the class by going to <a href="http://www.gavilan.edu/disted/">http://www.gavilan.edu/disted/</a> , click on your class link, and email the instructor at <a href="mailto:phowell@gavilan.edu">phowell@gavilan.edu</a> . Students who have not begun the class or contacted the instructor by 5 pm on Monday, February 5 will be dropped from the class.							
6513	LEC	BU110	HOWELL P	3.40	3.0	S	0900A-1200P

## CSIS 54L Perl Programming Lab

**Corequisite:** CSIS 54 Perl Programming  
**Transferable:** CSU; UC

Supplemental practice in coursework associated with this course is provided. Concurrent enrollment in CSIS 54 is required.

4891	ONLINE	HOWELL P	3.40	1.0	DHR	0000-0000	38
 This online class will be delivered entirely over the internet. After enrolling, start the class by going to <a href="http://www.gavilan.edu/disted/">http://www.gavilan.edu/disted/</a> , click on your class link, and email the instructor at <a href="mailto:phowell@gavilan.edu">phowell@gavilan.edu</a> . Students who have not begun the class or contacted the instructor by 5 pm on Monday, February 5 will be dropped from the class.							
6064	LAB	BU110	HOWELL P	1.40	1.0	S&2	1200P-0100P

## CSIS 61 Introduction to Geographic Information Systems

**Advisory:** CSIS 1 or CSIS 2 or equivalent computer experience.  
**Transferable:** CSU; UC

The Geographic Information Systems (GIS) class introduces students to and teaches them how to use desktop GIS software. GIS is a computer-based data-processing tool used to analyze and manage spatial information that combines computers and geography. May be repeated three times for credit. This course has the option of a letter grade or credit/no credit.

6065	L/L	BU111	STAFF	6.80	4.0	Th&2	0600P-0950P
------	-----	-------	-------	------	-----	------	-------------

## CSIS 74 Advanced Photoshop

**Advisory:** CSIS 75 PhotoShop I  
**Transferable:** CSU; GAV-GE: C1

This course is for the PhotoShop-experienced student and explores PhotoShop's advanced features in depth. Students work on projects, which challenge their creativity and technical ability, and will be encouraged to develop complex projects for the web and for the printed page. May be repeated three times for credit. This course has the option of a letter grade or credit/no credit. This course is also listed as ART 74 and DM 74.

6066	LEC	MHG8	GRZAN R	3.40	3.0	Th	0630P-0940P
Above class meets at Morgan Hill Community site							

Sect. Type Room Instructor Hrs. Units Days Begin-End Footnotes

**CSIS 75 PhotoShop I - Adobe PhotoShop**

Advisory: CSIS 124 (Windows Fundamentals), CSIS 2L  
Transferable: CSU; GAV-GE: C1

This course is based on the software application Adobe PhotoShop. Students learn to scan photographs and manipulate them using Photoshop tool box and special effects filters. They will learn to correct photos; mask image using channels; create duotone, tritone, and quadtone images; prepare photos for use in printing and on the web. This course has the option of a letter grade or credit/no credit. May be repeated three times for credit. Students who repeat this course will learn new and advanced features. This course is also listed as DM 75.

4234	L/L	LI128	BEEDE R	5.70	3.0	TuTh&2	1120A-1240P	25 35
6067	L/L	MHG8	GRZAN R	5.70	3.0	Tu&2	0630P-0920P	8 25 35

Above class meets at Morgan Hill Community site

**CSIS 77 Introduction to Digital Media and its Tools**

Advisory: CSIS 124, CSIS 1, CSIS 2/2L, CSIS 3, or familiarity using the Macintosh or Windows operating system.  
Transferable: CSU; UC; GAV-GE: C1

An introduction to the field of digital media, including history, social impact, concepts, career options and industry trends. Applying learned visual and aural design principles, students will explore the use of computer-based tools in the design and production of digital media by creating and editing digital images, sounds, video, animation, and text. A comprehensive term project for publication on the web or CD ROM will be required. This course is also listed as ART 77 and DM 77. This course has the option of a letter grade or credit/no credit. May be repeated twice for credit.

4235	L/L	LI128	BEEDE R	5.70	3.0	TuTh&2	0945A-1110A	25 35
------	-----	-------	---------	------	-----	--------	-------------	-------

**CSIS 80 Digital Photography**

Advisory: CSIS 1 or CSIS 2/2L or ART 8A or equivalent computer experience.  
Transferable: CSU; UC; GAV-GE: C1

The study of digital photography from digital camera to the computer-based printer or digital media. Artistic, theoretical, and technical aspects will be considered. Topics include information about types and purchasing of digital cameras; theory, mechanics, and art of digital imagery; digital darkroom; eccentricities of digital photo taking; stitching photos for virtual reality; and preparing digital images for print, World Wide Web and other digital media. This course has the option of a letter grade or credit/no credit. This course is also listed as ART 80 and DM 80.

4236	L/L	LI128	EDBERG J	5.70	3.0	M&2	1245P-0325P	25 95
------	-----	-------	----------	------	-----	-----	-------------	-------

**CSIS 84 JavaScript Programming**

Advisory: CSIS 6  
Transferable: CSU; UC

Fundamentals of JavaScript client-side programming for Web pages requiring data collection or other user interaction. Students will create Web pages that execute on the client (personal system) using JavaScript. This course may be repeated one time for credit. This course has the option of a letter grade or credit/no credit.

4237	ONLINE	STAFF		4.60	2.0	DHR	0000-0000	11 38
03/26/07 - 05/25/07 This online class will be delivered entirely over the internet. After enrolling, start the class by going to <a href="http://www.gavilan.edu/disted/">http://www.gavilan.edu/disted/</a> , click on your class link, and email the instructor at xxx@gavilan.edu. Students who have not begun the class or contacted the instructor by 5 pm on Thursday, March 29 will be dropped from the class.								



**CSIS 85 Web Design I: Dreamweaver**

Advisory: CSIS 6 or basic knowledge of HTML.  
Transferable: CSU; GAV-GE: C1

Basic and intermediate principles of designing Web pages/sites using the Dreamweaver web design software and HTML. Emphasis will be on good design and the use of tables, frames, forms, rollovers, DHTML, XHTML, behaviors, and CSS. Also includes site maintenance and the integration of multimedia components such as graphics, sound, animation, and video. This course is for the content person to design, develop, and maintain effective Web sites. This course is also listed as ART 85 and DM 85. This course has the option of a grade or credit/no credit. May be repeated twice for credit.

4238	LEC	MHG8	CONREY J	3.30	2.0	Tu	1120A-0225P	11 25
02/06/07 - 05/01/07 Above class meets at Morgan Hill Community site								

Footnotes contain valuable information pertaining to your class selection. Footnotes follow class listings.

**CSIS 48 UNIX/Linux Operating System**



basic UNIX/Linux commands, test editing, files and directories, electronic pipes and filters

Now using Dreamweaver 8

**CSIS 85 Web Design I: Dreamweaver**

In this course you will learn to design, develop, and maintain effective Web sites.

DESIGN YOUR OWN WEB SITE!

Also listed as ART 85 & DM 85.

**CSIS 74 Advanced Photoshop CS2**



Learn the advanced features of **Photoshop CS2** and create professional artwork.

Also listed as ART 74 and DM 74.

Sign Up Now!

**CSIS 75 Photoshop I**

Learn to scan, correct and manipulate photos with *Adobe Photoshop CS2*

Sect. Type Room Instructor Hrs. Units Days Begin-End Footnotes

## CSIS 108 Digital Media Lab

**Advisory:** CSIS 1 or CSIS 2/2L or equivalent computer experience.  
**Transferable:** CSU; GAV-GE: C1

Supervised practice and individualized computer assisted learning of software applications and techniques commonly found in the design and production of digital media (e.g., digital art and imaging, digital photography, digital print, digital audio/video, web design/authoring, DVD/CD ROMs, animation). Supplements lecture courses. Open entry/exit, so may be added at anytime during the semester. This is a credit/no credit course. May be repeated three times for credit. Also listed as ART 108 and DM 108.

4239 LAB LI128 BEEDE R 1.70 .5 M 1110A-1245P 25 31

## CSIS 112 Keyboard Speed Building

**Advisory:** CSIS 122 or knowledge of keyboard with keyboarding speed of at least 25 wpm.  
**Transferable:** CSU

This self-paced course is designed for students who know the alphabetic keyboard by touch and who want to develop their keyboarding speed. Students will use a microcomputer to keyboard a series of straight-copy timings, which will enable them to achieve a high level of skill. This is a credit/no credit course. May be repeated once for a total of 1 unit.

4240 LAB BU110 GAFFNEY S 1.60 .5 DHR 0000-0000

## CSIS 114 Digital Media Production

**Advisory:** At least one of the following: ART 75, CGE 2, JOUR 18A, MUS 21, CSIS 7, CSIS 71, OR CSIS 77, or possess equivalent skills from any one of the following areas: digital media, computer graphics, digital print, film, TV/video, journalism (publishing), drawing or illustration, web design/ development, business/marketing, or programming.  
**Transferable:** CSU

A team oriented practicum that focuses on the application of learned skills to the production of digital media and digital print projects, such as web sites, CD ROM, and DVDs. Project development will be accomplished according to team derived master schedules. Lectures will be on project management, work coordination and production techniques, client-team interface, asset management and integration, budget estimates, testing, and copyright infringement. Please note that this is very much a team oriented class. This course has the option of a letter grade or credit/no credit. This course is also listed as ART 114 and DM 114.

4241 LEC LI128 BEEDE R 2.30 2.0 F 1110A-0115P 25

## CSIS 120 Computerized Accounting - QuickBooks

**Advisory:** CSIS 1 or CSIS 2 or the equivalent computer experience. ACCT 20 or ACCT 101 or ACCT 103 or ACCT 105 or the equivalent accounting experience.  
**Transferable:** CSU

An introduction to computer assisted accounting. Hands-on use of a microcomputer menu-driven accounting package to do general ledger, sales journal, cash receipts journal, cash payments journal, purchases journal, payroll, receivables, payables and related financial reports. This course has the option of a letter grade or credit/no credit. Repeatable whenever a new software package is adopted. This course is also listed as ACCT 120.

4242 LAB BU111 BARTAM 4.40 2.0 W&1.4 0945A-1240P 25 35

6068 LAB MHG5 BARTA M 4.40 2.0 M&1.4 0630P-0940P 25 35 96  
 Above class meets at Morgan Hill Community site

6515 L/L HOL 3 HARLOW T 4.40 2.0 F&1.4 0530P-0840P 25 35  
 Above class meets at Hollister Briggs site

## CSIS 121 Spreadsheet - MS Excel

**Advisory:** CSIS 1 or CSIS 2 or equivalent computer experience.  
**Transferable:** CSU

Introduction to the computer spreadsheet software. A hands-on approach to learning terms, commands, and applications of a spreadsheet program. This course will help prepare students for taking the Excel MOUS (Microsoft Office User Specialist) exams. This course has the option of a letter grade or credit/no credit and may be repeated for credit when the software changes.

4243 LEC BU118 ROBINSON V 2.60 2.0 F&2 0945A-1145P 11  
 02/02/07 - 03/23/07

4244 LEC MHG8 CONREY J 4.60 2.0 Th 1120A-0225P 11  
 02/01/07 - 04/26/07 Above class meets at Morgan Hill Community site

6069 LEC HOL3 LITTIG A 4.60 2.0 W 0555P-0955P 11  
 03/21/07 - 05/09/07 Above class meets at the Hollister Briggs site

Sect. Type Room Instructor Hrs. Units Days Begin-End Footnotes

## CSIS 122 Computer Keyboarding

**Transferable:** CSU

A self-paced course for students who wish to master the alphabetic and numeric keyboard on the computer. This course is designed for students who do not know the alphabetic keyboard by "touch" and for those who want to improve their ability to type straight copy with increased speed and accuracy. The course provides "hands-on" instruction to help students reach optimum computer keyboarding skills within a limited time. This is a credit/no credit course. Course may be repeated until 3 units are accrued.

4245 LAB BU110 GAFFNEY S 1.60 .5 day-time see instructor 7 9

4246 LAB BU110 GAFFNEY S 3.40 1.0 day-time see instructor 7 9

4247 LAB SV002 THOMPSON F 1.70 .5 MW 0900A-1100A  
 01/31/07 - 05/16/07 See Footnote: Above class meets Off Campus

4248 LAB SV002 THOMPSON F 3.40 1.0 MW 0900A-1100A  
 01/31/07 - 05/16/07 See Footnote: Above class meets Off Campus

4249 LAB HOL3 BRYSON M 1.70 .5 MW 0900A-1105A  
 Above class meets at the Hollister Briggs site

4250 LAB HOL3 BRYSON M 3.40 1.0 MW 0900A-1105A  
 Above class meets at the Hollister Briggs site

4251 LAB HOL3 BRYSON M 1.70 .5 MW 1120A-0125P  
 Above class meets at the Hollister Briggs site

4252 LAB HOL3 BRYSON M 3.40 1.0 MW 1120A-0125P  
 Above class meets at the Hollister Briggs site

6070 LAB MHG5 HAMPTON 4.60 .5 S 0830A-1220P  
 02/10/07 - 05/19/07 Above class meets at Morgan Hill Community site

6071 LAB MHG5 HAMPTON 4.00 1.0 S 0830A-1220P  
 02/10/07 - 05/19/07 Above class meets at Morgan Hill Community site

6072 LAB HOL3 HAMPTON 3.40 1.0 M 0600P-0850P  
 Above class meets at the Hollister Briggs site

6073 LAB HOL3 HAMPTON 1.60 .5 M 0600P-0850P  
 Above class meets at the Hollister Briggs site

6074 LAB BU110 GAFFNEY S 1.60 .5 Tu 0600P-0850P 7 9

6075 LAB BU110 GAFFNEY S 3.40 1.0 Tu 0600P-0850P 7 9

## CSIS 124 Windows Fundamentals

**Advisory:** Basic keyboarding skill.  
**Transferable:** CSU

This course provides fundamental information on the Windows environment for the computer. Introductory Windows operations and file management are covered. This is a credit/no credit course. This course may be repeated three times for credit.

4253 LEC SV002 THOMPSON F 4.00 1.0 MW 0900A-1100A 11  
 02/05/07 - 03/07/07 See Footnote: Above class meets Off Campus

4254 LEC BU111 MILAR E 1.50 1.0 M 0900A-1110A 11  
 02/12/07 - 04/30/07

4255 LEC HOL3 BRYSON M 4.60 1.0 MW 1120A-0125P 11  
 02/05/07 - 03/07/07 Above class meets at the Hollister Briggs site

6076 LEC MHG5 HAMPTON 4.00 1.0 S 0830A-1220P 11  
 02/17/07 - 03/17/07 Above class meets at Morgan Hill Community site

6077 LEC HOL3 HAMPTON 1.00 1.0 Th 0600P-0950P 11  
 02/08/07 - 03/08/07 Above class meets at the Hollister Briggs site



## Brush Up your Software Skills

Most Computer Applications classes are repeatable.

Sect. Type Room Instructor Hrs. Units Days Begin-End Footnotes

**CSIS 126 Word Processing - MS Word**

**Advisory:** Eligible for English 260 and basic keyboarding skills.  
**Transferable:** CSU

This introductory course for word processing with Windows is designed for business and non-business majors. Students will develop word processing skills to create a document, select and edit text, move and copy text, use the spelling, grammar, and thesaurus features, format text, and create headers, footnotes for a research paper. This course has the option of a letter grade or credit/no credit and may be repeated when the software changes.

4256	LEC	SV002	THOMPSON F	4.00	2.0	MW	0900A-1100A	11	
03/12/07 - 05/16/07 See Footnote: Above class meets Off Campus									
6078	LEC	MHG5	HAMPTON	4.00	2.0	S	0830A-1220P	11	
03/24/07 - 05/19/07 Above class meets at Morgan Hill Community site									
6079	LEC	BU111	MILAR E	2.30	2.0	M&2	1120A-1245P	11	
02/12/07 - 05/14/07									
6080	LEC	SV002	THOMPSON F	2.30	2.0	W	0600P-0910P	11	
02/21/07 - 05/16/07 See Footnote: Above class meets Off Campus									
6517	LEC	HOL3	HAMPTON	4.00	2.0	Th	0600P-0950P	11	
03/15/07 - 05/17/07 Above class meets at the Hollister Briggs site									

**CSIS 128 Database - MS Access**

**Advisory:** CSIS 1 or CSIS 2 or equivalent knowledge.  
**Transferable:** CSU

Introduction to Microsoft Access, a relational database management software tool. Students will learn to create and manage a database. This course will help prepare students for taking the Access MOUS (Microsoft Office User Specialist) exams. May be repeated three times for credit. This course has the option of a letter grade or credit/no credit.

6082	LEC	MHG8	CONREY J	4.60	2.0	W	0600P-0955P	11	
03/14/07 - 05/16/07 Above class meets at Morgan Hill Community site									

**CSIS 129 Presentation Graphics - MS PowerPoint**

**Advisory:** CSIS 126 or word processing skills in the Windows environment.  
**Transferable:** CSU

This introductory course in presentation graphics will use Microsoft Office's "PowerPoint" software to create a computerized presentation (slide show) with text and objects. This course is also listed as CMUN 129. This course has the option of a letter grade or credit/no credit. May be repeated three times for credit.

4258	LEC	HOL3	BRYSON M	4.60	1.0	MW	0900A-1105A	11	25
04/18/07 - 05/16/07 Above class meets at the Hollister Briggs site									
4878	LEC	LI120	ANDRADE A	1.0	1.0	MW	1245P-0200P	11	25
02/05/07 - 03/12/07									

**CSIS 140 Basic Digital Film/Video Production**

**Transferable:** CSU; UC; GAV-GE: C1

An on-line self-paced course covering the basics of film/video production and post production (editing) using "easy to use" computer software such as Apple's iMovie. Beneficial for students who are producing a video/film project as a requirement for another college course, extra skills development, or for self interest. Completion of the associated class or personal project in DVD format using either personal video equipment or the equipment in the Digital Media Studio is required. May be repeated twice for credit. This course has the option of a letter grade or credit/no credit. This course is also listed as ART 140 and DM 140.

4260	ONLINE	BEEDE R		1.00	1.0	DHR	0000-0000	25	38
This online class will be delivered entirely over the internet. After enrolling, start the class by going to <a href="http://www.gavilan.edu/disted/">http://www.gavilan.edu/disted/</a> , click on your class link, and email the instructor at <a href="mailto:rbeede@gavilan.edu">rbeede@gavilan.edu</a> . Students who have not begun the class or contacted the instructor by 5 pm on Monday, February 5 will be dropped from the class.									



**Services Available:**

Internet access ♦ Microsoft Office ♦ Spanish software  
 ♦ free printing in black and white ♦ minimal charge for  
 color printing ♦ scanning ♦ transparencies

Mon - Thurs: 8 am - 5 pm      Fri: 8 am - 2 pm

**BUSINESS/CSIS DEGREES & CERTIFICATES**



- Accounting
- Bioinformatics
- Business Computer Applications
- Business Economics
- Computer Networking
- Computer Programming
- General Business
- General Office
- Medical Office
- Programming for the Internet
- Scientific Programming
- UNIX Operating Systems
- Web Page Production Specialist



Consult the Gavilan Catalog for complete information or visit the website at [www.gavilan.edu](http://www.gavilan.edu)

**GRADUATION INFORMATION**



Call 408-848-4737 for details on the graduation process.

The deadline for filling out a petition for graduation for spring is April, 2007.

**Admissions & Records**





Sect. Type Room Instructor Hrs. Units Days Begin-End Footnotes

## CSIS 181 PC Hardware

**Advisory:** CSIS 124, CSIS 1 OR CSIS 2, or equivalent computer experience.  
**Transferable:** CSU

This course examines computing hardware, operating systems, and software applications from a technical side to enable students to select, install, maintain and optimize a computer system. This course will help prepare students to pursue the A+ Hardware Certification. This course has the option of a letter grade or credit/no credit.

6083	L/L	BU120	ROBINSON V	6.80	4.0	W	0600P-0950P	35
------	-----	-------	------------	------	-----	---	-------------	----

## CSIS 182 Operating Systems

**Advisory:** CSIS 1 or CSIS 2 or equivalent computer experience  
**Transferable:** CSU

This course will survey current computer operating systems such as Microsoft Windows 98, NT, 2000 and XP. Linux will also be covered. Topics include file system management, systems requirements, network systems integration, security, and regular maintenance procedures. This course has the option of a letter grade or credit/no credit.

6084	L/L	BU118	ROBINSON V	6.80	4.0	Tu	0600P-0950P	35
------	-----	-------	------------	------	-----	----	-------------	----

## CSIS 190 Occupational Work Experience/Computer Science

**Required:** Declared vocational major. Concurrent enrollment in seven or more units (including CWE units, except for summer school. For summer school, enrollment in one other class is required). Minimum 2.00 G.P.A.  
**Transferable:** CSU

College credit for learning experience obtained on the job in accordance with a training plan developed cooperatively between the employer, college and student. 75 hours per semester per unit or 60 hours per semester for unpaid experience. This is a credit/no credit course. May be taken for a maximum of 16 work experience units.

4261	WEX	BU125	KERR L	5.60	1.0	DHR	0000-0000	16
4262	WEX	BU125	KERR L	11.30	2.0	DHR	0000-0000	16
4263	WEX	BU125	KERR L	16.90	3.0	DHR	0000-0000	16
4264	WEX	BU125	KERR L	22.50	4.0	DHR	0000-0000	16

## CSIS 570 Computer Access Evaluation

**Advisory:** This course is intended for students with a verified disability who show a need for the use of adaptive computer programs and/or equipment or demonstrated academic deficit.  
**Transferable:** No

This course is intended to provide for in-depth computer access evaluation in order to determine an appropriate access environment for a student with a disability or multiple disabilities. This is a credit/no credit course. May be repeated as necessary based on measurable progress as documented in the student's Individual Education Plan or Student Educational Contract. This is an open entry, open exit course.

4265	LAB	LI105	MARINGER J	1.70	.5	day-time	see instructor	74 75
------	-----	-------	------------	------	----	----------	----------------	-------

## CSIS 571 Computer Assisted Instruction

**Advisory:** This course is intended for students with a verified disability who show a need for the use of adaptive computer programs and/or equipment or demonstrated academic deficit.  
**Transferable:** No

This course is an Assistive Computer Technology Lab designed for students who are eligible for Disabled Student Services. The course is designed to improve basic academic skills and/or cognitive processes through the use of appropriate software or to learn assistive devices designed to make computer accessible. Course content is based on individual educational plans which are developed for each student. This is a credit/no credit course. May be repeated as necessary based on measurable progress as documented in the student's Individual Education Plan or Student Educational Contract. This is an open entry, open exit course.

4266	LAB	LI105	MARINGER J	1.70	.5	day-time	see instructor	74 75
4267	LAB	LI105	MARINGER J	3.40	1.0	day-time	see instructor	74 75
4268	LAB	LI105	MARINGER J	6.80	2.0	day-time	see instructor	74 75

Sect. Type Room Instructor Hrs. Units Days Begin-End Footnotes

## CSIS 572 Adaptive Computer Basics

**Advisory:** This course is intended for students with a verified disability who show a need for the use of adaptive computer programs and/or equipment.  
**Transferable:** No

This course will include an introduction to the basic concept of how computers work, using the computer keyboard, word processing, computer ethics and presentation graphics. This course will be self-paced and adjusted so that students with learning, physical, or communicative disabilities can learn a number of adaptive devices designed to make computers accessible. This is a credit/no credit course. May be repeated as necessary based on measurable progress as documented in the student's Individual Education Plan or Student Educational Contract. This is an open entry, open exit course.

4269	L/L	LI105	MARINGER J	3.40	1.0	MW	1255P-0220P	74 75
------	-----	-------	------------	------	-----	----	-------------	-------

## Computerized Accounting: see ACCT 120

## COSMETOLOGY

### COS 200 Beginning Cosmetology

**Advisory:** Eligible for English 250, 260 and Mathematics 205.  
**Transferable:** No

Fundamental principles of the science/art of beauty culture including hair design, chemical services and cosmetic therapy.

4203	L/L	BU120	RAMIREZ G	28.10	12.0	F	0810A-0930A	27 29
		CO102	RAMIREZ G			TuWThF	0810A-0330P	

### COS 201 Intermediate Cosmetology

**Advisory:** Satisfactory completion of Cosmetology 200. Eligible for English 250, 260 and Mathematics 205.  
**Transferable:** No

Extended studies and techniques in tinting, bleaching, permanent waving, shaping, styling, acrylic nail, pedicuring, chemical straightening, soft perming, waxing, care of skin and make-up.

4204	L/L	CO102	HERNANDEZ R	28.10	12.0	TuWThF	0810A-0330P	27
------	-----	-------	-------------	-------	------	--------	-------------	----

### COS 202 Advanced Cosmetology

**Prerequisite:** Completion of COS 200 & 201.  
**Advisory:** Eligible for English 250, 260 and Mathematics 205.  
**Transferable:** No

Advanced techniques in tinting, lightening, hair design and cosmetic chemistry.

4205	L/L	CO102	KHANNA N	26.50	12.0	TuWThF	0810A-0330P	27
------	-----	-------	----------	-------	------	--------	-------------	----

### COS 203 Practicum

**Prerequisite:** Completion of COS 200, 201 and 202.  
**Advisory:** Eligible for English 250, 260 and Mathematics 205.  
**Transferable:** No

Advanced techniques in tinting, lightening, hair and design and cosmetic chemistry.

4206	L/L	CO102	KHANNA N	9.40	4.0	TuWThF	0810A-0330P	27
4207	L/L	CO102	KHANNA N	14.10	6.0	TuWThF	0810A-0330P	27
4208	L/L	CO102	ANDRE M	14.10	6.0	TuWThF	0810A-0330P	27
		HU104	ANDRE M			Tu	0100P-0330P	
4209	L/L	CO102	ANDRE M	4.60	2.0	TuWThF	0810A-0330P	
4210	L/L	CO102	ANDRE M	23.40	10.0	TuWThF	0810A-0330P	27
4211	L/L	CO102	KHANNA N	18.70	8.0	TuWThF	0810A-0330P	

Sect. Type Room Instructor Hrs. Units Days Begin-End Footnotes

Sect. Type Room Instructor Hrs. Units Days Begin-End Footnotes

**COS 205 State Board Review**

Advisory: Cosmetology 201.  
Transferable: No

State Board exam procedures and standards.

4212 LAB CO102 HERNANDEZR 5.50 2.0 M 0810A-0330P

**COS 223 Independent Study**

Required: The study outline prepared by the student and the instructor must be filed with the Department and the Area Dean.

Transferable: No

Designed to afford selected students specialized opportunities for exploring areas at the independent study level. The courses may involve extensive library work, research in the community, or special projects. May be repeated until six units of credit are accrued. This course has the option of a letter grade or credit/no credit.

4213 IND CO102 HERNANDEZR 6.80 2.0 DHR 0000-0000

**COS 290 Occupational Work Experience/Cosmetology**

Required: Declared vocational major. Concurrent enrollment in seven or more units (including CWE units, except for summer school. For summer school, enrollment in one other class is required). Minimum 2.00 G.P.A.

Transferable: No

College credit for learning experience obtained on the job in accordance with a training plan developed cooperatively between the employer, college and student. 75 hours per semester per unit or 60 hours per semester for unpaid experience. This is a credit/no credit course. May be taken for a maximum of 16 work experience units.

4214	WEX	BU125	KERR L	11.30	2.0	DHR	0000-0000	16
4215	WEX	BU125	KERR L	11.30	2.0	DHR	0000-0000	
4216	WEX	BU125	KERR L	16.90	3.0	DHR	0000-0000	
4217	WEX	BU125	KERR L	22.50	4.0	DHR	0000-0000	

**CPR: see Allied Health**

**Desktop Publishing: see CSIS or DM**

**DIGITAL MEDIA**

**DM 6 Web Page Authoring I**

Advisory: CSIS 1 or CSIS 2 or CSIS 3/LIB 3 advised.

Transferable: CSU; GAV-GE: E2

An introduction to using Hypertext Mark-Up Language (HTML) and Extensible HTML (XHTML) to create web pages which can be uploaded and displayed on the World Wide Web. Students will use HTML/XHTML to create web pages with text in various sizes and colors, links to other sites, background color or patterns, graphics, tables and mailto links. Principles of design and color as they apply to screen presentations will be included. This course has the option of a letter grade or credit/no credit. May be repeated three times for credit. Also listed as CSIS 6 and LIB 6.

4277 ONLINE HOWELL J 4.60 2.0 DHR 0000-0000 11 25 38

01/31/07 - 03/24/07 This online class will be delivered entirely over the internet. After enrolling, start the class by going to <http://www.gavilan.edu/disted/>, click on your class link, and email the instructor at [jhowell@gavilan.edu](mailto:jhowell@gavilan.edu). Students who have not begun the class or contacted the instructor by 5 pm on Monday, February 5 will be dropped from the class.

4278 ONLINE VENABLE E 4.60 2.0 DHR 0000-0000 11 25 38

03/26/07 - 05/21/07 This online class will be delivered entirely over the internet. After enrolling, start the class by going to <http://www.gavilan.edu/disted/>, click on your class link, and email the instructor at [evenable@gavilan.edu](mailto:evenable@gavilan.edu). Students who have not begun the class or contacted the instructor by 5 pm on Monday, February 5 will be dropped from the class.

**LEARN TO BUILD AND MAINTAIN COMPUTERS**



**CSIS 181, PC HARDWARE**

**CSIS 182, OPERATING SYSTEMS**

PREPARATION FOR A+ CERTIFICATION EXAMS  
(Get discounts on Exams)

Today 4 out of five camera sales are **DIGITAL**

step up to  
**Digital Photography**

ART/DM/CSIS 80

**Want to learn about Digital Media?**

We offer classes in:  
Audio/Video  
Photography  
Photoshop  
Design  
Production  
and much more!

**New for Summer!**  
The Institute for  
Digital Media  
Entertainment  
July 5-28

**STUDIO DM**  
Gavilan's state of the art Digital Media lab

Sect. Type Room Instructor Hrs. Units Days Begin-End Footnotes

**DM 23 Independent Study**

**Required:** The study outline prepared by the student and the instructor must be filed with the department and the dean.  
**Transferable:** CSU

Designed to afford selected students specialized opportunities for exploring areas at the independent study level. The courses may involve extensive library work, research in the community, or special projects. May be repeated until six units of credit are accrued. This course has the option of a letter grade or credit/no credit.

4280	IND	LI128	BEEDER	2.30	2.0	DHR	0000-0000	
4281	IND	LI128	BEEDER	1.00	1.0	DHR	0000-0000	

**DM 60 3D Animation I**

**Advisory:** Any of the following: DM 77, DM 75, DM 76, DM 110, CGD 2, ART 48A, ART 48B, or equivalent.  
**Transferable:** CSU

Fundamentals and aesthetics of digital 3D animation, including modeling, animation and rendering. Focus on computer animation tools and techniques including workflow and storyboarding. Builds a solid foundation for developing character animation, architecture walkthroughs, and special-effect sequences. This course has the option of a letter grade or credit/no credit.

4282	L/L	LI126	PEACOCKR	5.70	3.0	TuTh&2	1255P-0220P	20 35
------	-----	-------	----------	------	-----	--------	-------------	-------

**DM 61 3D Animation II**

**Advisory:** DM 60 or equivalent experience.  
**Transferable:** CSU

This class extends animation into character modeling, soundtrack synchronization, advanced shading, lighting, rendering and compositing techniques. May include topics such as particles, dynamics, and scripting. This course has the option of a letter grade or credit/no credit.

4283	L/L	LI126	PEACOCKR	5.70	3.0	W&2	1255P-0220P	35
------	-----	-------	----------	------	-----	-----	-------------	----

**DM 74 Advanced Photoshop**

**Advisory:** CSIS 75 PhotoShop I  
**Transferable:** CSU; GAV-GE: C1

This course is for the PhotoShop-experienced student and explores PhotoShop's advanced features in depth. Students work on projects, which challenge their creativity and technical ability, and will be encouraged to develop complex projects for the web and for the printed page. May be repeated three times for credit. This course has the option of a letter grade or credit/no credit. This course is also listed as ART 74 and CSIS 74.

6085	LEC	MHG8	GRZAN R	3.40	3.0	Th	0630P-0940P	25
Above class meets at Morgan Hill Community site								

**DM 75 PhotoShop I - Adobe PhotoShop**

**Advisory:** CSIS 124 (Windows Fundamentals), CSIS 2L  
**Transferable:** CSU; GAV-GE: C1

This course is based on the software application Adobe PhotoShop. Students learn to scan photographs and manipulate them using Photoshop tool box and special effects filters. They will learn to correct photos; mask image using channels; create duotone, tritone, and quadtone images; prepare photos for use in printing and on the web. This course has the option of a letter grade or credit/no credit. May be repeated three times for credit. Students who repeat this course will learn new and advanced features. This course is also listed as CSIS 75.

4284	L/L	LI128	BEEDER	5.70	3.0	TuTh&2	1120A-1240P	25 35
6086	L/L	MHG8	GRZAN R	5.70	3.0	Tu&2	0630P-0940P	8 25 35
Above class meets at Morgan Hill Community site								

**Don't go to the wrong city**

MHG = Morgan Hill Community Center site

HOL = Hollister Briggs Building site

Sect. Type Room Instructor Hrs. Units Days Begin-End Footnotes

**DM 77 Introduction to Digital Media and its Tools**

**Advisory:** CSIS 124, CSIS 1, CSIS 2/2L, CSIS 3, or familiarity using the Macintosh or Windows operating system.  
**Transferable:** CSU; UC; GAV-GE: C1

An introduction to the field of digital media, including history, social impact, concepts, career options and industry trends. Applying learned visual and aural design principles, students will explore the use of computer-based tools in the design and production of digital media by creating and editing digital images, sounds, video, animation, and text. A comprehensive term project for publication on the web or CD ROM will be required. This course is also listed as ART 77 and CSIS 77. This course has the option of a letter grade or credit/no credit. May be repeated twice for credit.

4285	L/L	LI128	BEEDER	5.70	3.0	TuTh&2	0945A-1110A	25 35
------	-----	-------	--------	------	-----	--------	-------------	-------

**DM 80 Digital Photography**

**Advisory:** CSIS 1 or CSIS 2/2L or ART 8A or equivalent computer experience.  
**Transferable:** CSU; UC; GAV-GE: C1

The study of digital photography from digital camera to the computer-based printer or digital media. Artistic, theoretical, and technical aspects will be considered. Topics include information about types and purchasing of digital cameras; theory, mechanics, and art of digital imagery; digital darkroom; eccentricities of digital photo taking; stitching photos for virtual reality; and preparing digital images for print, World Wide Web and other digital media. This course has the option of a letter grade or credit/no credit. This course is also listed as ART 80 and CSIS 80.

4286	L/L	LI128	EDBERG J	5.70	3.0	M&2	1255P-0315P	25 35 95
------	-----	-------	----------	------	-----	-----	-------------	----------

**DM 85 Web Design I: Dreamweaver**

**Advisory:** CSIS 6 or basic knowledge of HTML.  
**Transferable:** CSU; GAV-GE: C1

Basic and intermediate principles of designing Web pages/sites using the Dreamweaver web design software and HTML. Emphasis will be on good design and the use of tables, frames, forms, rollovers, DHTML, XHTML, behaviors, and CSS. Also includes site maintenance and the integration of multimedia components such as graphics, sound, animation, and video. This course is for the content person to design, develop, and maintain effective Web sites. This course is also listed as ART 85 and CSIS 85. This course has the option of a letter grade or credit/no credit. May be repeated twice for credit.

4288	LEC	MHG8	CONREY J	3.30	2.0	Tu	1120A-0225P	11 25
02/06/07 - 05/01/07 Above class meets at Morgan Hill Community site								

**DM 108 Digital Media Lab**

**Advisory:** CSIS 1 or CSIS 2/2L or equivalent computer experience.  
**Transferable:** CSU; GAV-GE: C1

Supervised practice and individualized computer assisted learning or software applications and techniques commonly found in the design and production of digital media (e.g., digital art and imaging, digital photography, digital print, digital audio/video, web design design/authoring, DVD/CD ROMs, animation). Supplements lecture courses. Open entry/exit, so may be added anytime during the semester. This is a credit/no credit course. Also listed as ART 108 and CSIS 108.

4289	LAB	LI128	BEEDER	6.80	2.0	DHR	0000-0000	
4290	LAB	LI128	BEEDER	1.70	.5	M	1110A-1245P	25 31



**DM 111 Sound Design for Digital Media**

**Advisory:** CSIS 1 or CSIS 2/2L or equivalent computer knowledge.  
**Transferable:** CSU

Study and practice of the techniques and aesthetics of sound design especially for digital media (i.e., digital video/film, DVD, video games, WWW, and presentations.) Recording (including live audio), mixing and processing of Foley effects, ADR, voice-overs, sound tracks, and narration. This is not a music composition course, but use of sampled and electronic music/loops for creating background music will also be studied. This course has the option of a letter grade or credit/no credit.

4291	L/L	LI128	BEEDER	5.70	3.0	MW&2	1120A-1245P	
------	-----	-------	--------	------	-----	------	-------------	--

Sect. Type Room Instructor Hrs. Units Days Begin-End Footnotes

**DM 114 Digital Media Production**

**Advisory:** At least one of the following: ART 75, CGE 2, JOUR 18A, MUS 21, CSIS 7, CSIS 71, OR CSIS 77. or possess equivalent skills from any one of the following areas: digital media, computer graphics, digital print, film, TV/video, journalism (publishing), drawing or illustration, web design/ development, business/marketing, or programming.  
**Transferable:** CSU

A team oriented practicum that focuses on the application of learned skills to the production of digital media and digital print projects, such as web sites, CD ROM, and DVDs. Project development will be accomplished according to team derived master schedules. Lectures will be on project management, work coordination and production techniques, client-team interface, asset management and integration, budget estimates, testing, and copyright infringement. Please note that this is very much a team oriented class. This course has the option of a letter grade or credit/no credit. This course is also listed as ART 114 and CSIS 114.

4292 LEC LI128 BEEDE R 2.30 2.0 F 1110A-0115P 25

**DM 117 Motion Graphics/Special Effects**

**Advisory:** DM/ART/CSIS 113 or DM/ART/CSIS 140 or DM/ART/CSIS 77 or THEA 17A or basic knowledge of digital video/film editing.  
**Transferable:** CSU; UC

Study of the design of motion graphics and special effects used in digital video and film, web, multimedia, and interactive games. Includes video/graphics compositing techniques, 2D animation, basic 3D animation, and special effects commonly generated in digital post-production. Software such as Adobe After Effects or Apple's Motion will be used. May be repeated for credit. This course has the option of a letter grade or credit/non-credit. This course is also listed as ART 117 and CSIS 117.

4293 L/L LI128 BEEDE R 5.70 3.0 MW&amp;2 0945A-1110A 25 31

**DM 140 Basic Digital Film/Video Production**

**Transferable:** CSU; UC; GAV-GE: C1

An on-line self-paced course covering the basics of film/video production and post production (editing) using "easy to use" computer software such as Apple's iMovie. Beneficial for students who are producing a video/film project as a requirement for another college course, extra skills development, or for self interest. Completion of the associated class or personal project in DVD format using either personal video equipment or the equipment in the Digital Media Studio is required. May be repeated twice for credit. This course has the option of a letter grade or credit/no credit. This course is also listed as ART 140 and CSIS 140.

4295 ONLINE BEEDE R 1.00 1.0 DHR 0000-0000 25 38

This online class will be delivered entirely over the internet. After enrolling, start the class by going to <http://www.gavilan.edu/disted/>, click on your class link, and email the instructor at [rbeede@gavilan.edu](mailto:rbeede@gavilan.edu). Students who have not begun the class or contacted the instructor by 5 pm on Monday, February 5 will be dropped from the class.

**Drama: See Theatre Arts****Early Childhood Education: See Child Development****Earth Science: See Geology, Geography****ECOLOGY****ECOL 1 Conservation of Natural Resources**

**Advisory:** Eligible for English 250 and English 260.

**Transferable:** CSU; UC; CSU-GE: B2, B3; IGETC: 5B; GAV-GE: B2, B3

This course examines the fundamentals of ecology (the study of the relationships between organisms and their environment) with special emphasis on human effects on the environment. Topics of discussion will include ecosystem dynamics, resources, pollution, population growth, and the clash between economic and political policy and the environment.

4296 L/L LS101 HUBBARD J 6.80 4.0 TuTh 1255P-0220P 1

LS102 HUBBARD J Tu 0230P-0535P

4297 L/L LS101 HUBBARD J 6.00 4.0 TuTh 1255P-0220P 1

LS102 HUBBARD J Th 0230P-0535P

**Footnotes contain valuable information pertaining to your class selection. Footnotes follow class listings.**

Sect. Type Room Instructor Hrs. Units Days Begin-End Footnotes

**ECONOMICS****ECON 1 Principles of Macroeconomics**

**Advisory:** Eligible for English 1A and Mathematics 233.

**Transferable:** CSU; UC; CSU-GE: D2; IGETC: 4B; GAV-GE: D2; CAN: ECON 2

Introduction to the principles of macroeconomics, social organization of the economy; supply and demand; the determinants of national income and production, economic growth, the global economy and trade, employment, prices, savings and investment; the nature and effectiveness of monetary and fiscal policy. This course has the option of a letter grade or credit/no credit.

4298 LEC BU120 MILLER K 3.40 3.0 TuTh 1120A-1250P

4299 LEC BU120 MILLER K 3.40 3.0 MW 1255P-0210P

6087 LEC SS205 MILLER K 3.40 3.0 Tu 0600P-0910P

**ECON 2 Principles of Microeconomics**

**Advisory:** Eligible for English 260, English 250 and Mathematics 233.

**Transferable:** CSU; UC; CSU-GE: D2; IGETC: 4B; GAV-GE: D2; CAN: ECON 4

Introduction to microeconomic principles and theory; supply, demand; product and factor price determination, resource allocation, costs, revenues, and profits under different competitive situations; international trade; government regulation and taxation. Note: Economics 1 is not a prerequisite for Economics 2. This course has the option of a letter grade or credit/no credit.

4300 LEC BU120 MILLER K 3.40 3.0 MW 1120A-1245P

6088 LEC MHG3 STAFF 3.40 3.0 S 0900A-1205P

Above class meets at Morgan Hill Community site

**ECON 11 Statistics for Business and Economics**

**Prerequisite:** Mathematics 233.

**Transferable:** CSU; UC; CSU-GE: B4; IGETC: 2A; GAV-GE: B4

Statistical methods for business/economics analysis; descriptive statistics, inference, correlation and regression, probability, time series analysis. This course has the option of a letter grade or credit/no credit. This course is also listed as GBUS 11.

6089 LEC BU118 STAFF 4.50 4.0 MW 0600P-0805P 25

**ECON 14 Personal Finance**

**Advisory:** Math 400

**Transferable:** CSU

This course is designed to assist individuals to analyze their financial affairs for lifelong decision making. Elements and concepts of financial planning and decision making in the areas of budgeting, taxes, borrowing, money management, insurance, investments, retirement, and estate planning will be examined. This course is also listed as GBUS 14. This course has the option of a letter grade or credit/no credit.

6090 LEC MHG 12 STAFF 3.40 3.0 S 0800A-1105P 25

Above class meets at the Morgan Hill Community site

**Education: see Child Development**

## Campus under construction

# ROOM NUMBERS MAY CHANGE!

Check room numbers online before your first class.

## Choose a **THEME** for your English class:

Find the number, by the course section number, that corresponds to a theme below.



- 1 Explore consumerism and wild alternatives.
- 2 Explore the great American classics.
- 3 Explore a little basic science and technology on the way to making you a competent, college-level writer.
- 4 Explore the great literature of the human condition, challenging you to respond to literary art, science fiction, music, tragedy and the joy of life and living.
- 5 Focus on defying social norms.
- 6 Focus on the environment, including where we live and what we eat.

- 7 Develop your understanding of our multicultural society through literature.
- 8 Play with learning: Understand how kids grow through reading and writing.
- 9 Focus on issues of childhood, growing up too fast, and the blurred line between the roles of adult/child.
- 10 Take a nature walk through the literature of the American West.
- 11 Take a journey into Southern literature.
- 12 Speak up and speak out: Develop your voice at home, at school, and in the world.
- 13 First Year Experience: Focus on bridging worlds and navigating frontiers.
- 14 Puente: Focus on Mexican American/Latino literature.
- 15 Learn to be a skeptic, ask questions, believe nothing for granted and have the courage of your convictions. Not for those convinced that all life's answers lie in the paranormal and supernatural.

## ENGLISH

### ENGL 1A Composition

**Prerequisite:** English 250 and English 260 or English 250 and SSCI 270A or English 250 and SSCI 270B with a grade of 'C' or better or satisfactory score on the English placement examination.

**Transferable:** CSU; UC; CSU-GE: A2; IGETC: 1A; GAV-GE: A2; CAN: ENGL 2, ENGL SEQ. A

This is a writing course which emphasizes expository writing, argumentative writing, and critical reading of expository prose. It is meant to train students in clear thinking and reasoned support of ideas. Students will be given the opportunity to read models of good expository and argumentative prose and learn the techniques of good writing. These include choosing appropriate subjects, developing restricted, unified, and precise theses and presenting supporting evidence in a logical, lucid, and effective manner. To achieve this end, students write no fewer than six essays and read at least five works, two of which are book length.

#### LEARNING COMMUNITY SECTION:

- 14 4305 LEC HU103 CANDELARIA X 3.40 3.0 TuTh 0945A-1110A 182  
The above class is part of a Puente learning community. You must enroll in ALL corequisite courses. See the ENGLISH - PUENTE (below)

#### OTHER SECTIONS:

4301	LEC	MHG4	JAMES R	3.40	3.0	TuTh	0810A-0935A	1
Above class meets at Morgan Hill Community site								
2	4302	LEC	CJ500	LUOMA D	3.40	3.0	TuTh	0810A-0935A 1
3	4303	LEC	HU103	SANDLER S	3.40	3.0	F	0810A-1120A 1
4	4304	LEC	HU103	SANDLER S	3.40	3.0	MW	0945A-1110A 1
5	4306	LEC	HOL4	SALVIN C	3.40	3.0	TuTh	0945A-1110A 1
Above class meets at the Hollister Briggs site								
	4307	LEC	HU103	WISDOM K	3.40	3.0	MW	1120A-1245P 1
	4308	LEC	CJ500	CONDON D	3.40	3.0	TuTh	1120A-1245P 1
	4309	LEC	CJ500	LAU D	3.40	3.0	MW	1255P-0220P 1
	4310	LEC	HU102	JACKSON S	3.40	3.0	TuTh	1255P-0220P 1
	4311	LEC	HU103	STAFF	3.40	3.0	MW	0230P-0355P 1
	4312	LEC	HU102	JACKSON S	3.40	3.0	TuTh	0400P-0525P 1
10	4313	ONLINE	HESSE D	3.40	3.0	DHR	0000-0000 1	
This online class will be delivered entirely over the internet. After enrolling, start the class by going to <a href="http://www.gavilan.edu/disted/">http://www.gavilan.edu/disted/</a> , click on your class link, and email the instructor at <a href="mailto:hesse@gavilan.edu">hesse@gavilan.edu</a> . Students who have not begun the class or contacted the instructor by 5 pm on Monday, February 5 will be dropped from the class.								
	4314	ONLINE	CHAFFIN C	3.40	3.0	DHR	0000-0000 1	
This online class will be delivered entirely over the internet. After enrolling, start the class by going to <a href="http://www.gavilan.edu/disted/">http://www.gavilan.edu/disted/</a> , click on your class link, and email the instructor at <a href="mailto:cchaffin@gavilan.edu">cchaffin@gavilan.edu</a> . Students who have not begun the class or contacted the instructor by 5 pm on Monday, February 5 will be dropped from the class.								
	6091	LEC	HU102	KOVACS M	3.40	3.0	S	0900A-1210P 1
3	6092	LEC	HU103	BRETT T	3.40	3.0	M	0630P-0940P 1
	6093	LEC	HOL6	PARKER V	3.40	3.0	Tu	0630P-0940P 1
Above class meets at the Hollister Briggs site								
	6094	LEC	MHG3	JACKSON J	3.40	3.0	Th	0630P-0940P 1
Above class meets at Morgan Hill Community site								

### ENGL 1B Composition and Literature

**Prerequisite:** English 1A with a grade of "C" or better.

**Transferable:** CSU; UC; CSU-GE: C ; IGETC: 3B; GAV-GE: C2; CAN: ENGL 4, ENGL SEQ. A

English 1B continues the work begun in 1A, but now the emphasis shifts to writing expository prose in conjunction with reading and analyzing imaginative literature. Students are to write as fledgling critics and use the text as a basis for other forms of reflection. The reading requirement includes short stories, poetry, drama, and at least two novels. Course work will also include fundamentals of research writing.

	4315	LEC	MHG10	JAMES R	3.40	3.0	MW	0810A-0935A 1
Above class meets at Morgan Hill Community site								
2	4316	LEC	HU102	LUOMA D	3.40	3.0	F	0810A-1120A 1
	4317	LEC	HU102	RICHARDS G	3.40	3.0	MW	0945A-1110A 1
2	4318	LEC	CJ500	LUOMA D	3.40	3.0	TuTh	0945A-1110A 1
	4319	LEC	CH102	RICHARDS G	3.40	3.0	TuTh	1120A-1245P 1
1	4320	LEC	HU102	JACKSON S	3.40	3.0	TuTh	0230P-0355P 1
	4321	ONLINE	WISDOM K	3.40	3.0	DHR	0000-0000 1	
This online class will be delivered entirely over the internet. After enrolling, start the class by going to <a href="http://www.gavilan.edu/disted/">http://www.gavilan.edu/disted/</a> , click on your class link, and email the instructor at <a href="mailto:kwisdom@gavilan.edu">kwisdom@gavilan.edu</a> . Students who have not begun the class or contacted the instructor by 5 pm on Monday, February 5 will be dropped from the class.								
	4322	ONLINE	WARREN K	3.40	3.0	DHR	0000-0000 1	
This online class will be delivered entirely over the internet. After enrolling, start the class by going to <a href="http://www.gavilan.edu/disted/">http://www.gavilan.edu/disted/</a> , click on your class link, and email the instructor at <a href="mailto:kwarren@gavilan.edu">kwarren@gavilan.edu</a> . Students who have not begun the class or contacted the instructor by 5 pm on Monday, February 5 will be dropped from the class.								
4	6095	LEC	HU102	BRETT T	3.40	3.0	Th	0630P-0940P 1



## ENGLISH - PUENTE

The Puente Project is a two-semester program that combines three components: writing, counseling and mentoring to support students to transfer to four-year universities and colleges. The Guidance 1 course focuses on self-assessment and career development. The English 1A course focuses on Mexican American/Latino literature. The program is open to all eligible students. For more information, call Celia Marquez, Puente Co-Coordinator at 408-848-4807.

### ENGL 1A Composition

4305 LEC HU103 CANDELARIA X 3.40 3.0 TuTh 0945A-1110A 18 82

### GUID 1 Self Assessment and Career Development

4419 LEC CH102 MARQUEZ C 2.30 2.0 M 1120A-1220P 50 82 89  
W 1120A-1225P

Sect. Type Room Instructor Hrs. Units Days Begin-End Footnotes

**ENGL 1C Critical Reasoning and Writing**

Prerequisite: English 1A with a grade of "C" or better.

Transferable: CSU; UC; CSU-GE: A3; IGETC: 1B; GAV-GE: C2

This course is designed to develop critical thinking, reading, and writing skills beyond the level achieved in English 1A. The emphasis is on critical analysis of arguments and the development of the ability to integrate the principles of critical thinking into essay writing.

4323	LEC	HU102	WISDOM K	3.40	3.0	MW	0810A-0935A	1
4324	LEC	HOL5	VILLARREAL A	3.40	3.0	TuTh	0945A-1110A	1
Above class meets at the Hollister Briggs site								
4325	LEC	CJ500	CONDON D	3.40	3.0	TuTh	1255P-0220P	1
4326	LEC	CJ500	LAU D	3.40	3.0	MW	0230P-0355P	1
4327	LEC	HU103	SOLTIS M	3.40	3.0	TuTh	0400P-0525P	1
4328	ONLINE	CANDELARIA X		3.40	3.0	DHR	0000-0000	1

This online class will be delivered entirely over the internet. After enrolling, start the class by going to <http://www.gavilan.edu/disted/>, click on your class link, and email the instructor at [xcandelaria@gavilan.edu](mailto:xcandelaria@gavilan.edu). Students who have not begun the class or contacted the instructor by 5 pm on Monday, February 5 will be dropped from the class.



6096	LEC	HU103	BRETT T	3.40	3.0	W	0630P-0940P	1
------	-----	-------	---------	------	-----	---	-------------	---

**ENGL 2C Introduction to Film and Fiction**

Prerequisite: Eligible for English 1A.

Transferable: CSU; UC; CSU-GE: C2; IGETC: 3B; GAV-GE: C2

This is a literature course in analysis of the novel and film as art forms. The student will read several novels, view the films based on the novels, and discuss the difference in techniques, both orally and in writing.

6097	LEC	SS214	RICHARDS G	3.40	3.0	W	0630P-0940P	
------	-----	-------	------------	------	-----	---	-------------	--

**NEW ENGL 2J Mythology**

Prerequisite: Eligible for English 1A.

Transferable: CSU; UC; CSU-GE: C2; IGETC: 3B; GAV-GE: C2

This course is a survey of myths from around the world, with an emphasis on literary analysis of the myths. The course covers the purposes and types of myths; the development of myths and mythological characters, the recurring elements of mythological structures, the influence of mythology on contemporary texts.

4329	LEC	SS111	CANDELARIA X	3.40	3.0	TuTh	1120A-1245P	
------	-----	-------	--------------	------	-----	------	-------------	--

**ENGL 4B British Literature - 1798 to Present**

Prerequisite: Eligible for English 1A.

Transferable: CSU; UC; CSU-GE: C2; IGETC: 3B; GAV-GE: C2; CAN: ENGL 10, ENGL SEQ. B

This course is a study of the masters of British literature, covering writers such as Wordsworth, Coleridge, Shelly, Keats, Tennyson, Browning, Bronte, Hardy, Hopkins, Yeats, Woolf, Joyce, Lawrence, Eliot, and Lessing. English 4B covers 1798 A.D. to the present. Note: This course need not be taken in sequence.

4330	ONLINE	JAMES R		3.40	3.0	DHR	0000-0000	38
------	--------	---------	--	------	-----	-----	-----------	----

This online class will be delivered entirely over the internet. After enrolling, start the class by going to <http://www.gavilan.edu/disted/>, click on your class link, and email the instructor at [rjames@gavilan.edu](mailto:rjames@gavilan.edu). Students who have not begun the class or contacted the instructor by 5 pm on Monday, February 5 will be dropped from the class.

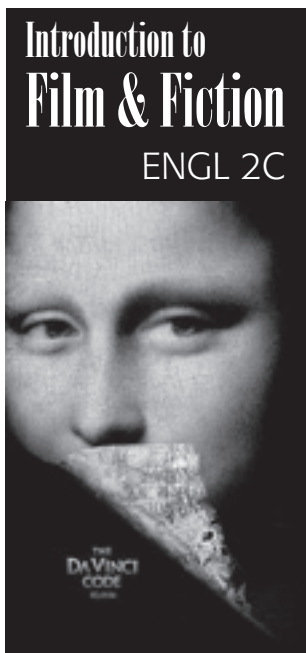

Instructor - Grant Richards

- The DaVinci Code*
- Pride and Prejudice*
- Million Dollar Baby*
- Mystic River*
- A History of Violence*
- Cold Mountain*
- Sideways*
- Motorcycle Diaries*
- Closer*
- Fight Club*
- Notebook*
- High Fidelity*
- The Shawshank Redemption*
- To Kill a Mockingbird*
- One Flew Over the Cuckoo's Nest*
- Chocolat*
- LA Confidential*
- Get Shorty and more!*

*This class can fulfill your IGETC humanities transfer requirement.*



**NEW ENGL 2J Mythology**

Instructor: Xochi Candelaria

This course offers an exploration of the major figures and themes of Greek, Aztec and African mythologies.

*Transferable to UC and CSU. Satisfies the Humanities requirement under both the CSU and IGETC GE patterns.*

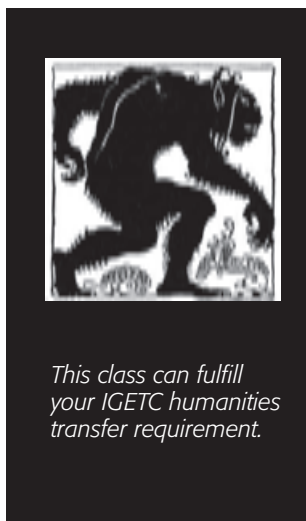

*This class can fulfill your IGETC humanities transfer requirement.*

**ENGL 4B**

**British Literature 1789 to Present**

Instructor: Robert James

Now offered Online

Have you met the prerequisite?  
**It's required!**

Footnotes contain valuable information pertaining to your class selection. Footnotes follow class listings.

Sect. Type Room Instructor Hrs. Units Days Begin-End Footnotes

**ENGL 9A Introduction to Creative Writing**

**Prerequisite:** Eligible for English 1A.

**Transferable:** CSU; UC; CSU-GE: C2; GAV-GE: C2; CAN: ENGL 6

This course includes the writing, reading, and critical discussions of various forms of poetry and fiction.

4331	LEC	SS111	SANDLERS	3.40	3.0	MW	1120A-1245P
6098	LEC	HU102	CANDELARIA X	3.40	3.0	W	0530P-0840P

**ENGL 9B Advanced Creative Writing**

**Prerequisite:** English 9A with a grade of credit or C or better.

**Transferable:** CSU; UC; CSU-GE: C2; GAV-GE: C2

This class is a continuation of English 9A, with the emphasis shifting to publication. The genre of non-fiction will be the primary focus, but the genres of fiction will also be taught at a more comprehensive level than in English 9A. The process of finding a market for one's work will be followed step by step. The class may compile and publish "Soaring", Gavilan's literary magazine, each spring semester.

4332	LEC	SS111	SANDLERS	3.40	3.0	MW	1120A-1245P
6099	LEC	HU102	CANDELARIA X	3.40	3.0	W	0530P-0840P

**ENGL 9C Poetry Writing**

**Prerequisite:** English 9A with a grade or credit or C or better.

**Transferable:** CSU; UC; CSU-GE: C2; GAV-GE: C2

This course includes the writing, reading, and critical discussions of various forms of poetry.

4333	LEC	SS111	SANDLERS	3.40	3.0	MW	1120A-1245P
6100	LEC	HU102	CANDELARIA X	3.40	3.0	W	0530P-0840P

**ENGL 12A Tutoring Writers: Training, Theory & Practice**

**Advisory:** Eligible for English 1A.

**Transferable:** CSU

Fundamentals of compositional theory, the writing process, peer-to-peer communication, interacting with faculty and educational institutions and effective responses to writing will be covered. In addition, students will gain an understanding of the basic history, methodology and practice of writing pedagogy while developing a writing community that aids in connecting them to their own writing practice.

4334	LEC	LI120	SMITH K	1.00	1.0	Th	0230P-0400P	13
4335	LEC	LI120	SMITH K	2.30	2.0	Th	0230P-0435P	13

Sect. Type Room Instructor Hrs. Units Days Begin-End Footnotes

**ENGL 12B Tutoring Writers: Training, Theory & Practice**

**Advisory:** Eligible for English 1A.

**Transferable:** CSU

Fundamentals of compositional theory, the writing process, peer-to-peer communication, interacting with faculty and educational institutions and effective responses to writing will be covered. In addition, students will gain an understanding of the basic history, methodology and practice of writing pedagogy while developing a writing community that aids in connecting them to their own writing practice.

4336	LEC	LI120	SMITH K	1.00	1.0	Th	0230P-0400P
4337	LEC	LI120	SMITH K	2.30	2.0	Th	0230P-0435P

**ENGL 12C Tutoring Writers: Training, Theory & Practice**

**Advisory:** Eligible for English 1A.

**Transferable:** CSU

Fundamentals of compositional theory, the writing process, peer-to-peer communication, interacting with faculty and educational institutions and effective responses to writing will be covered. In addition, students will gain an understanding of the basic history, methodology and practice of writing pedagogy while developing a writing community that aids in connecting them to their own writing practice.

4338	LEC	LI120	SMITH K	1.00	1.0	Th	0230P-0400P
4339	LEC	LI120	SMITH K	2.30	2.0	Th	0230P-0435P

**ENGL 23 Independent Study**

**Required:** The study outline prepared by the student and the instructor must be filed with the department and the dean.

**Transferable:** CSU

Designed to afford selected students specialized opportunities for exploring areas at the independent study level. The courses may involve extensive library work, research in the community, or special projects. May be repeated until six units of credit are accrued. This course has the option of a letter grade or credit/no credit.

4340	IND	HU111	RICHARDS G	3.40	1.0	DHR	0000-0000	22
4341	IND	HU112	CANDELARIA X	6.40	2.0	DHR	0000-0000	22
4342	IND	LI202	CROOK E	6.40	2.0	DHR	0000-0000	22
4343	IND	SS103	SALVIN C	6.40	2.0	DHR	0000-0000	22
4344	IND	SS109	WARREN K	3.40	1.0	DHR	0000-0000	22
4347	IND	LI120	SMITH K	6.40	2.0	DHR	0000-0000	22



Instructor: Xochiquezta Candelaria was raised in San Juan Bautista, CA and holds degrees from UC Berkeley and New York University. Her work has appeared in *The Nation*, *New England Review*, *Gulf Coast*, and other magazines.



Instructor: Scott Sandler is from Los Angeles, where he was managing editor of the *Northridge Review* for three years. He received his M.A. in English with a creative writing emphasis from the University of Southern Mississippi. Scott's work has been published in the *Santa Monica Review*, *Product*, and other magazines.

**English 9A, B, C**

**CREATIVE**  
*Writing*

*This class fulfills your CSU humanities transfer requirement.*

Sect. Type Room Instructor Hrs. Units Days Begin-End Footnotes

**ENGL 250 Practical Writing**

**Prerequisite:** English 440 or ESL 563 with a grade of 'C' or better or satisfactory score on the English placement examination.  
**Transferable:** No; GAV-GE: A2

This course covers writing clear, correct, effective essays and learning preliminary research skills.

**1**  
**2**  
**3** Your ENGL 250 class has a theme. See list on page 84.

**LEARNING COMMUNITY SECTIONS** Require co-requisites of English CD 2 or PSYC 2 - see ad on page 71:

3	4360	L/L	HU102 LI171	CROOK E CROOK E	4.40 3.0	MW Tu	1255P-0220P 1255P-0155P	1 18 36
3	4361	L/L	HU102 LI171	CROOK E CROOK E	4.40 3.0	MW Th	1255P-0220P 1255P-0155P	1 18 36
3	4903	L/L	HU102 LI171	CROOK E CROOK E	4.40 3.0	MW Tu	1255P-0220P 1255P-0155P	1 18 36
3	4904	L/L	HU102 LI171	CROOK E CROOK E	4.40 3.0	MW Th	1255P-0220P 1255P-0155P	1 18 36

**FIRST YEAR EXPERIENCE SECTIONS** Require co-requisites of English 260 & GUID 1. See ad:

1B	4358	L/L	HU102 SS111	HULL K HULL K	4.40 3.0	TuTh Tu	1120A-1245P 0835A-0935A	1 18 78
1B	4359	L/L	HU102 SS111	HULL K HULL K	4.40 3.0	TuTh Th	1120A-1245P 0835A-0935A	1 18 78
1B	4362	L/L	HU103 SS111	HULL K HULL K	4.40 3.0	TuTh F	1255P-0220P 0920A-1020P	1 18 78
1B	4363	L/L	HU103 SS111	HULL K HULL K	4.40 3.0	TuTh F	1255P-0220P 1030A-1130A	1 18 78

**OTHER SECTIONS:**

5	4348	L/L	SS203 LI171	GATEWOOD J GATEWOOD J	4.40 3.0	MW F	0810A-0935A 0810A-0910A	1 18
5	4349	L/L	SS203 LI171	GATEWOOD J GATEWOOD J	4.40 3.0	MW F	0810A-0935A 0920A-1020A	1 18
1	4350	L/L	HOL4	SALVIN C SALVIN C	4.40 3.0	MW M	0945A-1110A 1115A-1215P	1 18

Above class meets at the Hollister Briggs site.

1	4351	L/L	HOL4	SALVIN C SALVIN C	4.40 3.0	MW W	0945A-1110A 1115A-1215P	1 18
---	------	-----	------	----------------------	----------	---------	----------------------------	------

Above class meets at the Hollister Briggs site.

	4352	L/L	SS203 LI120	CAMOZZI A CAMOZZI A	4.40 3.0	TuTh Tu	0945A-1110A 0835A-0935A	1 18
--	------	-----	----------------	------------------------	----------	------------	----------------------------	------

	4353	L/L	SS203 LI120	CAMOZZI A CAMOZZI A	4.40 3.0	TuTh Th	0945A-1110A 0835A-0935A	1 18
--	------	-----	----------------	------------------------	----------	------------	----------------------------	------

5	4354	L/L	SS203 LI171	GATEWOOD J GATEWOOD J	4.40 3.0	MW F	1120A-1245P 1030A-1130A	1 18
---	------	-----	----------------	--------------------------	----------	---------	----------------------------	------

5	4355	L/L	SS203 LI171	GATEWOOD J GATEWOOD J	4.40 3.0	MW F	1120A-1245P 1140A-1240P	1 18
---	------	-----	----------------	--------------------------	----------	---------	----------------------------	------

	4356	L/L	MHG11 MHG4	STAFF STAFF	4.40 3.0	MW M	1120A-1245P 1255P-0155P	1 18
--	------	-----	---------------	----------------	----------	---------	----------------------------	------

Above class meets at Morgan Hill Community site.

	4357	L/L	MHG11 MHG4	STAFF STAFF	4.40 3.0	MW W	1120A-1245P 1255P-0155P	1 18
--	------	-----	---------------	----------------	----------	---------	----------------------------	------

Above class meets at Morgan Hill Community site.

	4364	L/L	SS203 LI171	CAMOZZI A CAMOZZI A	4.40 3.0	TuTh Tu	1255P-0220P 0230P-0330P	1 18
--	------	-----	----------------	------------------------	----------	------------	----------------------------	------

	4365	L/L	SS203 LI171	CAMOZZI A CAMOZZI A	4.40 3.0	TuTh Th	1255P-0220P 0230P-0330P	1 18
--	------	-----	----------------	------------------------	----------	------------	----------------------------	------

7	4366	L/L	SS203 LI171	STAFF STAFF	4.40 3.0	MW M	0400P-0525P 0245P-0345P	1 18
---	------	-----	----------------	----------------	----------	---------	----------------------------	------

7	4367	L/L	SS203 LI171	STAFF STAFF	4.40 3.0	MW W	0400P-0525P 0245P-0345P	1 18
---	------	-----	----------------	----------------	----------	---------	----------------------------	------

	6101	L/L	HOL6	PARKER V	4.40 3.0	Th	0530P-0940P	1 18
--	------	-----	------	----------	----------	----	-------------	------

Above class meets at the Hollister Briggs site

	6102	L/L	SS203	GRAY J	4.40 3.0	M W	0700P-0905P	1 18 48
--	------	-----	-------	--------	----------	-----	-------------	---------



**Is this your first year at Gavilan? Looking for a community of people like you? Then this learning community program is specially designed for you.** The first year of college can be challenging for many students. By studying and working together with your classmates and instructors, in this program you'll develop a strong network of support to help you succeed. You'll improve your reading and writing skills and also explore options for majors, transferring, and careers. Building a strong foundation in your first year will put you on the road to success throughout your college experience.

**The Program:** Students will take reading, writing and guidance together because these skills are needed to succeed in college classes.

**Bridging Worlds and Navigating Frontiers** is this semester's theme.

**The following classes are part of a First Year Experience learning community. You must enroll in all three courses.**

<b>ENGL 260</b>	<b>Preparation for College Reading</b>	4370 LEC	HU102	HOOPER J	3.40 3.0	TuTh	0945A-1110A	1 73
-----------------	--	----------	-------	----------	----------	------	-------------	------

<b>ENGL 250</b>	<b>Practical Writing</b>	4358 L/L	HU102 SS111	HULL K HULL K	4.40 3.0	TuTh Tu	1120A-1245P 0835A-0935A	1 18 78
-----------------	--------------------------	----------	----------------	------------------	----------	------------	----------------------------	---------

<b>GUID 1</b>	<b>Self-Assessment and Career Development</b>	4420 LEC	SC154N	WHITNEY C	2.30 2.0	W	1120A-0125P	85 89
---------------	---	----------	--------	-----------	----------	---	-------------	-------

\_\_\_\_\_ or \_\_\_\_\_

<b>ENGL 260</b>	<b>Preparation for College Reading</b>	4371 LEC	HU102	HOOPER J	3.40 3.0	TuTh	0945A-1110A	1 73
-----------------	--	----------	-------	----------	----------	------	-------------	------

<b>ENGL 250</b>	<b>Practical Writing</b>	4359 L/L	HU102 SS111	HULL K HULL K	4.40 3.0	TuTh Th	1120A-1245P 0835A-0935A	1 18 78
-----------------	--------------------------	----------	----------------	------------------	----------	------------	----------------------------	---------

<b>GUID 1</b>	<b>Self-Assessment and Career Development</b>	4421 LEC	SC154N	WHITNEY C	2.30 2.0	W	1120A-0125P	85 89
---------------	---	----------	--------	-----------	----------	---	-------------	-------

\_\_\_\_\_ or \_\_\_\_\_

<b>ENGL 260</b>	<b>Preparation for College Reading</b>	4373 LEC	HU103	HOOPER J	3.40 3.0	TuTh	1120A-1245P	1 73
-----------------	--	----------	-------	----------	----------	------	-------------	------

<b>ENGL 250</b>	<b>Practical Writing</b>	4362 L/L	HU103 SS111	HULL K HULL K	4.40 3.0	TuTh F	1255P-0220P 0920A-1020P	1 18 78
-----------------	--------------------------	----------	----------------	------------------	----------	-----------	----------------------------	---------

<b>GUID 1</b>	<b>Self-Assessment and Career Development</b>	4422 LEC	SS205	WHITNEY C	2.30 2.0	F	1140A-0145P	85 89
---------------	---	----------	-------	-----------	----------	---	-------------	-------

\_\_\_\_\_ or \_\_\_\_\_

<b>ENGL 260</b>	<b>Preparation for College Reading</b>	4374 LEC	HU103	HOOPER J	3.40 3.0	TuTh	1120A-1245P	1 73
-----------------	--	----------	-------	----------	----------	------	-------------	------

<b>ENGL 250</b>	<b>Practical Writing</b>	4363 L/L	HU103 SS111	HULL K HULL K	4.40 3.0	TuTh F	1255P-0220P 1030A-1130A	1 18 78
-----------------	--------------------------	----------	----------------	------------------	----------	-----------	----------------------------	---------

<b>GUID 1</b>	<b>Self-Assessment and Career Development</b>	4423 LEC	SS205	WHITNEY C	2.30 2.0	F	1140A-0145P	85 89
---------------	---	----------	-------	-----------	----------	---	-------------	-------



Sect. Type Room Instructor Hrs. Units Days Begin-End Footnotes

Sect. Type Room Instructor Hrs. Units Days Begin-End Footnotes

**ENGLISH - LEARNING COMMUNITIES**



The following groups of courses are learning communities. You must enroll in both complementary courses which have linked curriculum with the following theme: *Speak Up! Speak Out! Voices at Home, in School and in the World.*

**ENGL 420 Reading Improvement**

4376 L/L CJ500 WARREN K 4.40 3.0 MW 0945A-1110A 1 36  
LI120 WARREN K F 0910A-1010A

**ENGL 440 Basic Writing**

4389 L/L CJ500 WARREN K 4.40 3.0 MW 1120A-1245P 1 36 18  
LI120 WARREN K F 1020A-1120A

or

**ENGL 420 Reading Improvement**

4377 L/L CJ500 WARREN K 4.40 3.0 MW 0945A-1110A 1 36  
LI120 WARREN K M 1255P-0155P

**ENGL 440 Basic Writing**

4390 L/L CJ500 WARREN K 4.40 3.0 MW 1120A-1245P 1 36 18  
LI120 WARREN K W 1255P-0155P

or

**ENGL 420 Reading Improvement**

4379 L/L CJ500 SMITH K 4.40 3.0 MW 1120A-1245P 1 36  
LI120 SMITH K Th 1055A-1155A

**ENGL 440 Basic Writing**

4388 L/L CJ500 SMITH K 4.40 3.0 MW 0945A-1110A 1 18  
LI120 SMITH K Th 0945A-1045A

or

**ENGL 420 Reading Improvement**

4378 L/L CJ500 SMITH K 4.40 3.0 MW 1120A-1245P 1 36  
LI120 SMITH K Tu 1055A-1155A

**ENGL 440 Basic Writing**

4387 L/L CJ500 SMITH K 4.40 3.0 MW 0945A-1110A 1 18  
LI120 SMITH K Tu 0945A-1045A

**Your educational plan:**

You are expected to take the responsibility for scheduling an appointment with a counselor, preferably at least once a semester. The purpose of this appointment is to develop, review and update your educational plan to ensure that you are taking the appropriate courses to meet your educational goal.

**ENGL 260 Preparation for College Reading**

**Prerequisite:** Completion of English 420 or ESL 562 with a grade of 'C' or better or Assessment recommendation.  
**Transferable:** No; GAV-GE: A3

This is a course presenting strategies in the technique and practice of college level critical reading and thinking skills.

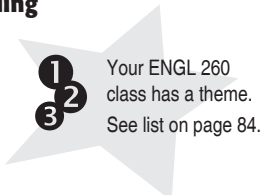

**LEARNING COMMUNITY SECTIONS:**

4370 LEC	HU102	HOOPER J	3.40	3.0	TuTh	0945A-1110A	1 73
Above class requires a co-requisite of First Year Experience English 250 and GUID 1							
4371 LEC	HU102	HOOPER J	3.40	3.0	TuTh	0945A-1110A	1 73
Above class requires a co-requisite of First Year Experience English 250 and GUID 1							
4373 LEC	HU103	HOOPER J	3.40	3.0	TuTh	1120A-1245P	1 73
Above class requires a co-requisite of First Year Experience English 250 and GUID 1							
4374 LEC	HU103	HOOPER J	3.40	3.0	TuTh	1120A-1245P	1 73
Above class requires a co-requisite of First Year Experience English 250 and GUID 1							

**OTHER SECTIONS:**

4368 LEC	HU102	TICE R	3.40	3.0	TuTh	0810A-0935A	1
4369 LEC	SS203	HOOPER J	3.40	3.0	MW	0945A-1110A	1
4372 LEC	SS203	JACKSON J	3.40	3.0	F	1030A-0140P	1
4375 LEC	SS203	HOOPER J	3.40	3.0	MW	1255P-0220P	1
6103 LEC	SS203	GRAY J	3.40	3.0	M W	0530P-0655P	1 48

**ENGL 420 Reading Improvement**

**Prerequisite:** Satisfactory score on the English placement examination.  
**Transferable:** No

This is a practical, "how to" course teaching various methods of learning and reading college material. Using group and individual instruction in vocabulary, comprehension, and study skills, the students will increase their ability to survive academically, to profit, grow and succeed in all college courses, and to enjoy reading and learning. Units earned in this course do not count toward the associate degree and/or certain certificate requirements.

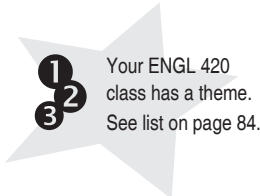

**LEARNING COMMUNITY SECTIONS:**

12 4376 L/L	CJ500	WARREN K	4.40	3.0	MW	0945A-1110A	1 36
	LI120	WARREN K			F	0910A-1010A	
12 4377 L/L	CJ500	WARREN K	4.40	3.0	MW	0945A-1110A	1 36
	LI120	WARREN K			M	1255P-0155P	
12 4379 L/L	CJ500	SMITH K	4.40	3.0	MW	1120A-1245P	1 36
	LI120	SMITH K			Th	1055A-1155A	
12 4378 L/L	CJ500	SMITH K	4.40	3.0	MW	1120A-1245P	1 36
	LI120	SMITH K			Tu	1055A-1155A	

**OTHER SECTIONS:**

4380 L/L	SS111	HIRASUNA S	4.40	3.0	MW	1255P-0220P	1
		HIRASUNA S			M	0230P-0330P	
4381 L/L	SS111	HIRASUNA S	4.40	3.0	MW	1255P-0220P	1
		HIRASUNA S			W	0230P-0330P	
4382 L/L	SS111	SOLTIS M	4.40	3.0	TuTh	1255P-0220P	1
		SOLTIS M			Tu	0230P-0330P	
4383 L/L	SS111	SOLTIS M	4.40	3.0	TuTh	1255P-0220P	1
		SOLTIS M			Th	0230P-0330P	
6104 L/L	SS203	GARDNER L	4.40	3.0	TuTh	0530P-0735P	1 48

Sect. Type Room Instructor Hrs. Units Days Begin-End Footnotes

Sect. Type Room Instructor Hrs. Units Days Begin-End Footnotes

**ENGL 439 Basic Grammar and Reading**

**Advisory:** Assessment recommendation.  
**Transferable:** No

This is a remediation course introducing basic reading and writing strategies, as well as study skills. Group and individual instruction will be used to build vocabulary, increase reading comprehension, develop study skills, and apply basic grammar to writing. Units earned in this course do not count toward the associate degree and/or certain certificate requirements. This is a credit/no credit course.

4384	L/L	LI120	TICE R	6.80	4.0	MW	0945A-1110A	
		SS111	TICE R			TuTh	0945A-1110A	

**ENGL 440 Basic Writing**

**Prerequisite:** Satisfactory score on the English placement examination.  
**Transferable:** No

This is an intensive study and application of basic grammar, sentence, and essay writing skills within the context of composing short essays. Units earned in this course do not count toward the associate degree and/or certain certificate requirements.

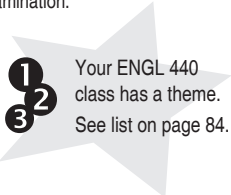

1 Your ENGL 440  
2 class has a theme.  
3 See list on page 84.

**LEARNING COMMUNITY SECTIONS:**

4387	L/L	CJ500	SMITH K	4.40	3.0	MW	0945A-1110A	1 18
		LI120	SMITH K			Tu	0945A-1045A	
4388	L/L	CJ500	SMITH K	4.40	3.0	MW	0945A-1110A	1 18
		LI120	SMITH K			Th	0945A-1045A	
4389	L/L	CJ500	WARREN K	4.40	3.0	MW	1120A-1245P	1 36 18
		LI120	WARREN K			F	1020A-1120A	
4390	L/L	CJ500	WARREN K	4.40	3.0	MW	1120A-1245P	1 36 18
		LI120	WARREN K			W	1255P-0155P	

**OTHER SECTIONS:**

4385	L/L	SS203	GIER J	4.40	3.0	TuTh	0810A-0935A	1 18
		LI171	GIER J			Tu	1010A-1110A	
4386	L/L	SS203	GIER J	4.40	3.0	TuTh	0810A-0935A	1 18
		LI171	GIER J			Th	1010A-1110A	
4391	L/L	HU102	CROOK E	4.40	3.0	MW	1120A-1245P	1 18
		LI171	CROOK E			Tu	1120A-1220P	
4392	L/L	HU102	CROOK E	4.40	3.0	MW	1120A-1245P	1 18
		LI171	CROOK E			Th	1120A-1220P	
4393	L/L	SS203	GIER J	4.40	3.0	TuTh	1120A-1245P	1 18
		LI171	GIER J			Tu	1255P-0155P	
4394	L/L	SS203	GIER J	4.40	3.0	TuTh	1120A-1245P	1 18
		LI171	GIER J			Th	1255P-0155P	
6105	L/L	SS203	GARDNER L	4.40	3.0	TuTh	0740P-0945P	1 18 48

**FACULTY Profile**

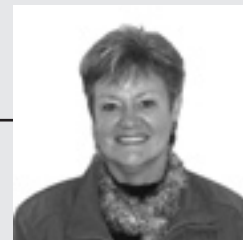

**Johanna Stewart:**

Johanna Stewart, Counselor/ASB Advisor (jstewart@gavilan.edu)  
Ms. Stewart has been a part-time counselor at Gavilan College. In her new role she will continue to counsel students, and will also serve as advisor to the Associated Student Body student governance organization. She holds an MA in Counseling Education from San Jose State University.

**Gavilan College**

**ENGLISH COMPOSITION COURSE SEQUENCE**

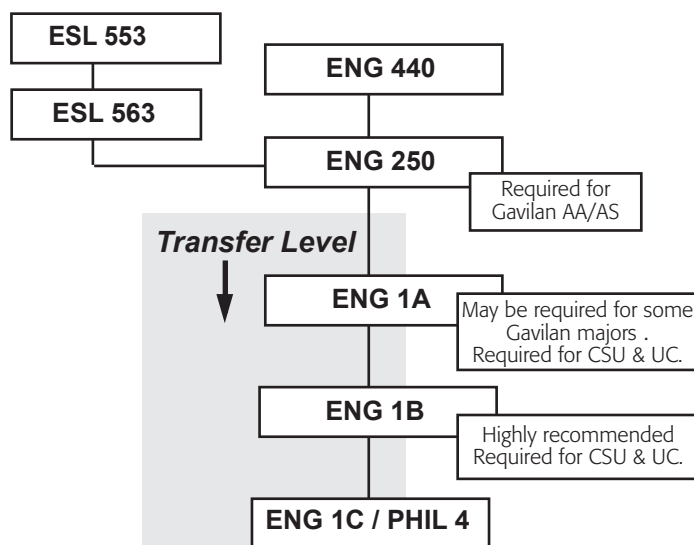

**Reading Course Sequence**

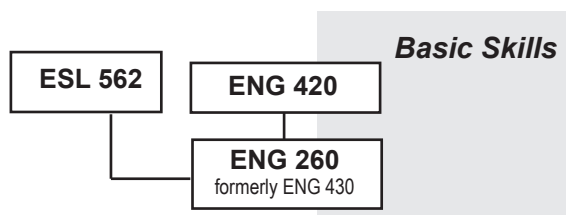

Multiple measures will be considered to determine your final course. Consult with a counselor to select the appropriate course placement.

**Footnotes contain valuable information pertaining to your class selection. Footnotes follow class listings.**

Sect. Type Room Instructor Hrs. Units Days Begin-End Footnotes

All new ESL students must go through the ESL assessment process. See page 32.

Todos los nuevos estudiantes de ESL deben tomar el examen de nivelación de ESL. Consulte la página 32.

## ENGLISH AS A SECOND LANGUAGE

Gavilan College ofrece cursos de Inglés como segundo idioma a todos los niveles, desde principiante hasta avanzado. Antes de inscribirse, los estudiantes deben hacer una cita para el examen de nivelación en la Oficina de Admisiones.

### ESL 501A Survival ESL I First Half

**Advisory:** ESL assessment recommendation

**Transferable:** No

This is the first half of a course in survival English for students with little or no oral or written English competency. It will give students basic vocabulary and familiarity in life skill areas such as the family, food, health, and occupations. The course integrates listening, speaking, reading, and writing. (ESL 501, 502, and 503 are sequential courses that may be taken in full form or in halves, preferably A before B.) This is a credit/no credit course.

6106	L/L	MHG12	PORCELLA A	5.70	3.0	M WTh	0600P-0735P
Above class meets at Morgan Hill Community site							

6107	L/L	HU101	GUZMAN D	5.70	3.0	TuWTh	0600P-0735P
------	-----	-------	----------	------	-----	-------	-------------

6108	L/L	HOL6	CISNEROS N	5.70	3.0	M WF	0600P-0735P
Above class meets at the Hollister Briggs site							

### ESL 501B Survival ESL I Second Half

**Advisory:** ESL 501A or ESL assessment recommendation

**Transferable:** No

This is a second half of a course in survival English for students with little or no oral or written English competency. It will give students basic vocabulary and familiarity in life skill areas such as the family, food, health, and occupations. The course integrates listening, speaking, reading, and writing. (ESL 501, 502, and 503 are sequential courses that may be taken in full form or in halves, preferably A before B.) This is a credit/no credit course.

6109	L/L	HU101	GUZMAN D	5.70	3.0	TuWTh	0745P-0920P
------	-----	-------	----------	------	-----	-------	-------------

6110	L/L	HOL6	CISNEROS N	5.70	3.0	M WF	0745P-0920P
Above class meets at the Hollister Briggs site							

### ESL 502A Survival ESL II First Half

**Advisory:** ESL 501 or ESL 501A and 501B or ESL assessment recommendation

**Transferable:** No

This is the first half of a second course in survival English for students with little oral or written English competency. It will give students expanded basic vocabulary and familiarity in life skill areas such as the weather, transportation, employment, and American holidays and customs. The course integrates listening, speaking, reading, and writing. (ESL 501, 502, and 503 are sequential courses that may be taken in full form or in halves, preferably A before B.) This is a credit/no credit course.

6111	L/L	HU104	LEE P	5.70	3.0	TuWTh	0600P-0735P
------	-----	-------	-------	------	-----	-------	-------------

### ESL 502B Survival ESL II Second Half

**Advisory:** ESL 501 or ESL 501A and 501B or ESL assessment recommendation

**Transferable:** No

This is the second half of the second course in survival English for students with little oral or written English competency. It will give students expanded basic vocabulary and familiarity in life skill areas such as weather, transportation, employment, and American holidays and customs. The course integrates listening, speaking, reading, writing. (ESL 501, 502, and 503 are sequential courses that may be taken in full form or in halves, preferably A before B.) This is a credit/no credit course.

6112	L/L	HOL4	DIEHL K	5.70	3.0	M WF	0600P-0735P
Above class meets at the Hollister Briggs site							

Sect. Type Room Instructor Hrs. Units Days Begin-End Footnotes

### ESL 503A Survival ESL III First Half

**Advisory:** ESL 502 or ESL 502A and 502B or ESL assessment recommendation

**Transferable:** No

This is the first half of a third course in survival English for students with beginning oral or written English competency. It will reinforce basic skills learned and continue to develop vocabulary and ease of communication in life skill areas such as the family, the larger community, health, employment, and leisure activities. The course integrates listening, speaking, reading, and writing. (ESL 501, 502, and 503 are sequential courses that may be taken in full form or in halves, preferably A before B.) This is a credit/no credit course.

6113	L/L	HU104	LEE P	5.70	3.0	TuWTh	0745P-0920P
------	-----	-------	-------	------	-----	-------	-------------

6114	L/L	HOL4	DIEHL K	5.70	3.0	M WF	0745P-0920P
Above class meets at the Hollister Briggs site							

### ESL 510A Basic ESL I

**Advisory:** Assessment Recommendation.

**Transferable:** No

This is an intensive, integrated-skill course for students with little English. Through listening, speaking, reading and writing activities, students learn to use the structures of English with increasing accuracy, while gaining basic life skills. This is a credit/no credit course.

4395	L/L	OE001	MORA J	12.90	8.0	F&2.3	0810A-1000A
			MORA J			MTuWTh&2	0810A-1015A

4396	L/L	OE001	POLIZZOTTO J	12.90	8.0	F&2.3	1025A-1215P
			POLIZZOTTO J			MTuWTh&2	1025A-1230P

### ESL 510B Basic ESL II

**Advisory:** ESL 510A or ESL assessment recommendation.

**Transferable:** No

This course is a continuation of ESL 510A. This is an intensive, integrated-skill program for students who function in a limited way in English. Through listening, speaking, reading and writing activities, students continue learning to use the structures of English with increasing accuracy, while gaining further basic life skills. This is a credit/no credit course.

4397	L/L	CH102	BAAMEUR K	12.90	8.0	F&2.3	0810A-1000A
			BAAMEUR K			MTuWTh&2	0810A-1015A

4398	L/L	OE002	WEXLER L	13.60	8.0	F&2.3	0925A-1115A
			WEXLER L			MTuWTh&2	0925A-1130A

### ESL 521 Beginning ESL Listening/Speaking

**Advisory:** ESL 510B or ESL Assessment Test Recommendation. Recommended concurrent enrollment in ESL 522 and 523.

**Transferable:** No

This course develops basic listening and speaking skills, moving from a functional survival context to academic readiness. Activities are directed at providing practice through listening exercises, role-play, pair work, small and large group discussion, interviews, and oral presentations.

4399	L/L	HU101	SANIDAD M	6.80	4.0	MW	0925A-1030A
			SANIDAD M			TuTh	0925A-1015A

### ESL 522 Beginning ESL Reading/Vocabulary

**Advisory:** ESL 510B or 510C or Assessment recommendation. Recommended concurrent enrollment in ESL 521 and 523.

**Transferable:** No

This course begins the development of reading skills and vocabulary through the application of different reading strategies to a variety of selections on topics of interest to academically-bound students.

4400	L/L	HU101	CARRILLO L	5.70	3.0	MW	1155A-1245P
			CARRILLO L			F	1155A-0100P

6115	L/L	LI100	SHELLEY A	5.70	3.0	TuWTh	0600P-0655P
			LI200				0705P-0740P

Sect. Type Room Instructor Hrs. Units Days Begin-End Footnotes

**ESL 523 Beginning ESL Grammar/Writing**

**Advisory:** ESL 510B or ESL Assessment Test recommendation. Recommended concurrent enrollment in ESL 521 and ESL 522.

**Transferable:** No

This is a beginning grammar/writing course for students with very basic grammar. The focus is on basic grammatical structures, punctuation and sentence skills.

4401 L/L HU104 CAMPBELL K 6.60 5.0 MWF 1040A-1130A  
CAMPBELL K TuTh 1040A-1145A

**ESL 531 Intermediate ESL Listening/Speaking I**

**Advisory:** ESL 521 or ESL Assessment Test Recommendation. Recommended concurrent enrollment in ESL 532 and 533.

**Transferable:** No

In this course, listening and speaking skills are developed through extended listening exercises, open-ended dialogues, pair and group discussions, oral interviews, and oral reports. Units earned in this course do not count toward the associate degree and/or certain certificate requirements.

4402 L/L HU101 WEXLER L 6.80 4.0 MW 0810A-0915A  
WEXLER L ThF 0810A-0900A

**ESL 532 Intermediate ESL Reading/Vocabulary I**

**Advisory:** ESL 522 or ESL Assessment Recommendation. Recommended concurrent enrollment in ESL 531 and 533.

**Transferable:** No

This course continues the development of reading skills and vocabulary through the application of different reading strategies to a variety of selections on topics of interest to academically-bound students.

4403 L/L OE002 CARRILLO L 5.70 3.0 TuTh 1155A-0120P

**ESL 533 Intermediate ESL Grammar/Writing I**

**Prerequisite:** ESL 523 with a grade of C or better or ESL Assessment Test recommendation.

**Corequisite:** Recommended concurrent enrollment in ESL 531 and ESL 532.

**Transferable:** No

This course involves the practice and refinement of sentence and paragraph skills, structure and punctuation. Students will learn basic use of the computer as a writing tool. Units earned in this course do not count toward the associate degree and/or certain certificate requirements.

4404 L/L LI100 LAWN B 6.60 5.0 MWF 1040A-1130A  
LAWN B TuTh 1040A-1145A

**ESL 541 Intermediate ESL Listening/Speaking II**

**Advisory:** ESL 531 or ESL Assessment Recommendation. Recommended concurrent enrollment in ESL 542 and 543.

**Transferable:** No

This course expands listening and speaking skills through extended listening exercises, open-ended dialogues, pair and group discussions, oral interviews, and oral reports. Students broaden vocabulary while listening to and speaking in both formal and informal, conversational and academic situations.

4405 L/L OE002 MAXWELL K 6.80 4.0 MW 0810A-0915A  
TuTh 0810A-0900A

**ESL 542 Intermediate ESL Reading/Vocabulary II**

**Advisory:** ESL 532 or ESL Assessment Recommendation. Recommended concurrent enrollment in ESL 541 and 543.

**Transferable:** No

This course begins the expansion of reading skills and vocabulary development through the application of different reading strategies to a variety of selections on topics of interest to academically-bound students including selections from literature.

4406 L/L OE002 WEXLER L 5.70 3.0 MW 1155A-1245P  
WEXLER L F 1155A-0100P

**OVERVIEW OF ESL COURSES**

L/S = Listening/Speaking  
R = Reading  
GW = Grammar/Writing

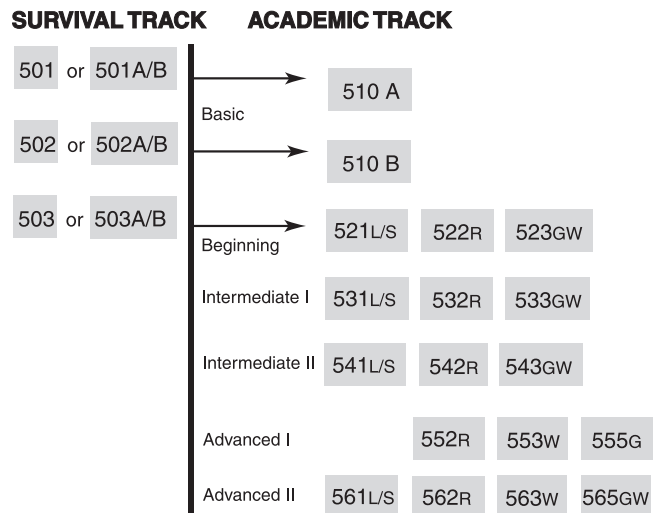

**SUPPLEMENTARY ESL COURSES:**

- ESL 546 Introduction to Computers/ESL
- ESL 556 Information Competency for ESL
- ESL 581 Pronunciation I
- ESL 582 Pronunciation II
- ESL 584 Culture through Film

ENGL 260 ENGL 250



**ESL 565 - EDITING FOR ESL WRITERS**

Do you want to write more clearly and avoid common ESL writing errors? Then check out our new Editing for ESL Writers class!



**Watch for NEW SUMMER ESL classes:**

**ESL 581 ESL PRONUNCIATION I and  
ESL 582 ESL PRONUNCIATION II**

Learn to speak more clearly and be better understood in two new ESL Pronunciation courses being offered this summer!

**ESL 584 CULTURE THROUGH FILM**

Learn more about American culture and improve your listening/speaking skills while watching movies in this new intermediate/advanced ESL class being offered this summer!

Sect. Type Room Instructor Hrs. Units Days Begin-End Footnotes

**ESL 543 Intermediate ESL Grammar/Writing II**

**Prerequisite:** ESL 533 with a grade of C or better or ESL assessment recommendation.  
**Corequisite:** Recommended concurrent enrollment in ESL 541 and ESL 542.  
**Transferable:** No  
 This course is a continuation of ESL 533. Units earned in this course do not count toward the associate degree and/or certain certificate requirements.

4407	L/L	LI100	LAWN B LAWN B	6.60 5.0	MWF TuTh	0925A-1015A 0925A-1030A
------	-----	-------	------------------	----------	-------------	----------------------------

**ESL 552 Advanced ESL Reading/Vocabulary I**

**Advisory:** ESL 542 or ESL Assessment Recommendation. Recommended concurrent enrollment in ESL 553 and/or ESL 555.  
**Transferable:** No  
 This course focuses on academic and critical thinking skills needed to increase reading comprehension and efficiency. Emphasis is on analyzing, making inferences, taking notes, supporting opinions, summarizing and expanding vocabulary. Readings are from academic texts and literature.

4408	LEC	LI100	LAWN B LAWN B	4.50 4.0	MTu ThF	1155A-1245P 1155A-0100P
------	-----	-------	------------------	----------	------------	----------------------------

**ESL 553 Advanced ESL Composition I**

**Prerequisite:** ESL 543 with a grade of C or better or ESL Assessment Test recommendation.  
**Corequisite:** Recommended concurrent enrollment in ESL 552 and ESL 555.  
**Transferable:** No  
 This course is a composition course for ESL students that develops college composition skills through a review of the parts and elements of the English paragraph and an introduction to the essay form. The course focuses on the development of a paragraph and expands to the writing of multiple paragraphs in an essay. Basic rhetorical patterns and methods of organization are covered using the multiple-draft approach to writing.

4409	L/L	LI100	SANIDAD M SANIDAD M	6.60 5.0	MWF TuTh	0810A-0900A 0810A-0915A
------	-----	-------	------------------------	----------	-------------	----------------------------

**ESL 555 Advanced ESL Grammar**

**Prerequisite:** ESL 543 with a grade of C or better or ESL Assessment Test Recommendation.  
**Advisory:** Recommended concurrent enrollment in ESL 553 and ESL 552.  
**Transferable:** No  
 This course is designed to help students improve their grammar usage so that they will be able to succeed in English composition courses. Students will enhance their writing skills by practicing with previously encountered basic structures as well as newly acquired more sophisticated ones.

4410	L/L	HU104	CAMPBELL K CAMPBELL K	6.60 5.0	MWF TuTh	0925A-1015A 0925A-1030A
------	-----	-------	--------------------------	----------	-------------	----------------------------

**ESL 562 Advanced ESL Reading/Vocabulary II**

**Advisory:** ESL 552 or ESL Assessment recommendation. Recommended concurrent enrollment in ESL 563.  
**Transferable:** No  
 This course prepares ESL students for mainstream college classes by reviewing a variety of reading skills, strategies, and topics from different academic disciplines. Students expand their academic vocabulary and read short stories or a novel for literary appreciation.

4411	LEC	HU104	CAMPBELL K CAMPBELL K	4.50 4.0	MTu ThF	0810A-0900A 0810A-0915A
------	-----	-------	--------------------------	----------	------------	----------------------------

**ESL 563 Advanced ESL Composition II**

**Prerequisite:** ESL 553 with a grade of "C" or better or ESL Assessment Test recommendation.  
**Advisory:** Recommended concurrent enrollment in ESL 561.  
**Transferable:** No  
 This course which is designed for ESL students, refines and further expands college composition skills through the writing of essays using the multiple-draft approach to writing. The course focuses on the structuring and development of an essay with the use of personal examples and/or outside sources. Students write in response to a variety of prompts and viewpoints on issues using different rhetorical patterns, and they are introduced to writing tasks used in academic disciplines other than English.

4412	L/L	HU104	TRACEY I TRACEY I	6.60 5.0	MWF TuTh	1155A-1245P 1155A-0100P
------	-----	-------	----------------------	----------	-------------	----------------------------

Sect. Type Room Instructor Hrs. Units Days Begin-End Footnotes



**ESL 565 Editing for ESL Writers**

Assessment recommendation.  
**Transferable:** No  
 This course is designed to help second language writers develop self-editing techniques to improve their writing. Students learn to identify and correct grammatical and usage errors in their writing as they become aware of general linguistic rules of English. Students learn to fix, and ultimately avoid, many of the errors commonly made by second language writers.

4413	L/L	HU101	MAXWELL K MAXWELL K	4.40 3.0	MW F	1040A-1130A 1040A-1145A
------	-----	-------	------------------------	----------	---------	----------------------------

**FRENCH**

**FRNH 1A Elementary French**

**Transferable:** CSU; UC; CSU-GE: C2; GAV-GE: C2  
 French 1A is a multi-skilled beginning level class with emphasis on understanding and speaking French. Students are introduced to the cultures and customs of various French-speaking countries.

4414	L/L	HU101	SANIDAD M	5.60 5.0	MTuWTh&2.8	1255P-0205P
------	-----	-------	-----------	----------	------------	-------------

**GEOGRAPHY**

see also CSIS 61 (Geographic Info. Systems)

**GEOG 1 Physical Geography**

**Advisory:** Eligible for English 250 and English 260.  
**Transferable:** CSU; UC; CSU-GE: B1, B3; IGETC: 5A; GAV-GE: B1, B3; CAN: GEOG 2  
 An introductory study of the basic physical elements of geography including climate, land forms, soils, water, and natural vegetation. The laboratory will include the tools and methods of geographers.

4905	L/L	HOL5	WILLAHAN D	5.60 3.0	MW	0945A-1215P
------	-----	------	------------	----------	----	-------------

Above class meets at Hollister Briggs site.

**GEOLOGY**

**GEO 1 Introduction to Geology**

**Advisory:** Eligible for English 250 and English 260.  
**Transferable:** CSU; UC; CSU-GE: B1, B3; IGETC: 5A; GAV-GE: B1, B3; CAN: GEOL 2  
 A study of the earth and the physical properties which modify the earth; minerals, rocks, geologic structures and processes.

4418	L/L	CH102	WILLAHAN D	6.80 4.0	MW	1255P-0405P 1
------	-----	-------	------------	----------	----	---------------

**GUIDANCE - PUENTE**

The Puente Project is a two-semester program that combines three components: writing, counseling and mentoring to support students to transfer to four-year universities and colleges. The Guidance 1 course focuses on self-assessment and career development. The English 1A course focuses on Mexican American/Latino literature. The program is open to all eligible students. For more information, call Celia Marquez, Puente Co-Coordinator at 408-848-4807.

**ENGL 1A Composition**

4305	LEC	HU103	CANDELARIA X	3.40 3.0	TuTh	0945A-1110A 1827
------	-----	-------	--------------	----------	------	------------------

**GUID 1 Self Assessment and Career Development**

4419	LEC	CH102	MARQUEZ C MARQUEZ C	2.30 2.0	M W	1120A-1220P 50 82 89 1120A-1225P
------	-----	-------	------------------------	----------	--------	-------------------------------------

Sect. Type Room Instructor Hrs. Units Days Begin-End Footnotes

**GUIDANCE**



**GUID 1 Self-Assessment and Career Development**

**Advisory:** Eligible for English 250 and English 260.  
**Transferable:** CSU; CSU-GE: E2; GAV-GE: E2

This course is designed to assist the student in learning more about personal values, personality, interests, exploration of career choice, and occupational opportunities through the use of various personal assessment instruments. The delivery options for this course also include online and self-paced formats. This course is also listed as PSYC 5.

**FIRST YEAR EXPERIENCE SECTIONS:**

4420	LEC	SC154N	WHITNEY C	2.30	2.0	W	1120A-0125P	85	89
This class requires co-requisites of First Year Experience English 250 and 260. See ad on this page.									
4421	LEC	SC154N	WHITNEY C	2.30	2.0	W	1120A-0125P	85	89
This class requires co-requisites of First Year Experience English 250 and 260. See ad on this page.									
4422	LEC	SS205	WHITNEY C	2.30	2.0	F	1140A-0145P	85	89
This class requires co-requisites of First Year Experience English 250 and 260. See ad on this page.									
4423	LEC	SS205	WHITNEY C	2.30	2.0	F	1140A-0145P	85	89
This class requires co-requisites of First Year Experience English 250 and 260. See ad on this page.									

**LEARNING COMMUNITY SECTION:**

4419	LEC	CH102	MARQUEZ C	2.30	2.0	M	1120A-1220P	50	82 89
			MARQUEZ C			W	1120A-1225P		

The above class is part of a Puente learning community. You must enroll in ALL corequisite courses. See the GUIDANCE - PUENTE section on page 92.

**OTHER SECTIONS:**

4424	LEC	OE001	TENNEY L	2.30	2.0	Tu	1255P-0200P	25	89
			TENNEY L			Th	1255P-0155P		
4425	ONLINE	SHARBONEAU		2.30	2.0	DHR	0000-0000	25	38 89
				This online class will be delivered entirely over the internet. After enrolling, start the class by going to <a href="http://www.gavilan.edu/disted/">http://www.gavilan.edu/disted/</a> , click on your class link, and email the instructor at <a href="mailto:rsharboneau@gavilan.edu">rsharboneau@gavilan.edu</a> . Students who have not begun the class or contacted the instructor by 5 pm on Monday, February 5 will be dropped from the class.					
4426	ONLINE	SHARBONEAU		2.30	2.0	DHR	0000-0000	25	38 89
				This online class will be delivered entirely over the internet. After enrolling, start the class by going to <a href="http://www.gavilan.edu/disted/">http://www.gavilan.edu/disted/</a> , click on your class link, and email the instructor at <a href="mailto:rsharboneau@gavilan.edu">rsharboneau@gavilan.edu</a> . Students who have not begun the class or contacted the instructor by 5 pm on Monday, February 5 will be dropped from the class.					

**GUID 22 Field Work and Service**

**Required:** Learning contracts must be filled out and signed by the student and the supervising instructor.

**Transferable:** CSU

Supervised field work within the college and with local agencies. Students serve in useful group activities in leadership roles prescribed for them by faculty or community agencies. A maximum of six units may be completed. This is a credit/no credit course.

4427	FEX	LI117	EASTMAN B	3.40	1.0	day-time	see instructor	22	73
------	-----	-------	-----------	------	-----	----------	----------------	----	----

**GUID 28 Tutoring Techniques**

**Advisory:** English 250.

**Transferable:** CSU

This course is designed to train students in effective tutoring skills, introduction to how people learn, teaching to modalities, and techniques of working with student anxiety. This course has the option of a letter grade or credit/no credit.

6119	L/L	LI116	RODERICK D	3.00	1.0	S	0930A-0230P	11	19 37
		LI120	RODERICK D			F	0100P-0235P		
02/23/07 - 04/06/07 This class meets seven Fridays, February 23 – April 6, 2007. There is only ONE Saturday meeting (March 3, 2007) that will meet in LI 116.									

**Is this your first year at Gavilan? Looking for a community of people like you? Then this learning community program is specially designed for you.** The first year of college can be challenging for many students. By studying and working together with your classmates and instructors, in this program you'll develop a strong network of support to help you succeed. You'll improve your reading and writing skills and also explore options for majors, transferring, and careers. Building a strong foundation in your first year will put you on the road to success throughout your college experience.

**The Program:** Students will take reading, writing and guidance together because these skills are needed to succeed in college classes.

**Bridging Worlds and Navigating Frontiers** is this semester's theme.

**The following classes are part of a First Year Experience learning community. You must enroll in all three courses.**

**ENGL 260 Preparation for College Reading**

4370	LEC	HU102	HOOPER J	3.40	3.0	TuTh	0945A-1110A	1	73
------	-----	-------	----------	------	-----	------	-------------	---	----

**ENGL 250 Practical Writing**

4358	L/L	HU102	HULL K	4.40	3.0	TuTh	1120A-1245P	1	18 78
		SS111	HULL K			Tu	0835A-0935A		

**GUID 1 Self-Assessment and Career Development**

4420	LEC	SC154N	WHITNEY C	2.30	2.0	W	1120A-0125P	85	89
------	-----	--------	-----------	------	-----	---	-------------	----	----

\_\_\_\_\_ or \_\_\_\_\_

**ENGL 260 Preparation for College Reading**

4371	LEC	HU102	HOOPER J	3.40	3.0	TuTh	0945A-1110A	1	73
------	-----	-------	----------	------	-----	------	-------------	---	----

**ENGL 250 Practical Writing**

4359	L/L	HU102	HULL K	4.40	3.0	TuTh	1120A-1245P	1	18 78
		SS111	HULL K			Th	0835A-0935A		

**GUID 1 Self-Assessment and Career Development**

4421	LEC	SC154N	WHITNEY C	2.30	2.0	W	1120A-0125P	85	89
------	-----	--------	-----------	------	-----	---	-------------	----	----

\_\_\_\_\_ or \_\_\_\_\_

**ENGL 260 Preparation for College Reading**

4373	LEC	HU103	HOOPER J	3.40	3.0	TuTh	1120A-1245P	1	73
------	-----	-------	----------	------	-----	------	-------------	---	----

**ENGL 250 Practical Writing**

4362	L/L	HU103	HULL K	4.40	3.0	TuTh	1255P-0220P	1	18 78
		SS111	HULL K			F	0920A-1020P		

**GUID 1 Self-Assessment and Career Development**

4422	LEC	SS205	WHITNEY C	2.30	2.0	F	1140A-0145P	85	89
------	-----	-------	-----------	------	-----	---	-------------	----	----

\_\_\_\_\_ or \_\_\_\_\_

**ENGL 260 Preparation for College Reading**

4374	LEC	HU103	HOOPER J	3.40	3.0	TuTh	1120A-1245P	1	73
------	-----	-------	----------	------	-----	------	-------------	---	----

**ENGL 250 Practical Writing**

4363	L/L	HU103	HULL K	4.40	3.0	TuTh	1255P-0220P	1	18 78
		SS111	HULL K			F	1030A-1130A		

**GUID 1 Self-Assessment and Career Development**

4423	LEC	SS205	WHITNEY C	2.30	2.0	F	1140A-0145P	85	89
------	-----	-------	-----------	------	-----	---	-------------	----	----

**Footnotes contain valuable information pertaining to your class selection. Footnotes follow class listings.**

Sect. Type Room Instructor Hrs. Units Days Begin-End Footnotes

**GUID 29 Tutoring Lab**

**Advisory:** Completion of, or concurrent enrollment in Guidance 28.  
**Transferable:** CSU

This course will allow students to gain valuable experience in the field of teaching. Students will practice the skills they have learned in Guidance 28. Guidance 29 may be repeated for a maximum of 2.0 units per semester and a maximum course total of 8.0 units. This is a credit/no credit course.

4428	LAB	LI116	RODERICK D	3.40	1.0	DHR	0000-0000	31
4429	LAB	LI116	RODERICK D	6.80	2.0	DHR	0000-0000	31

**GUID 250 Supervised Tutoring**

**Transferable:** No

Laboratory class emphasizing college learning skills, appropriate study techniques, and learning assistance utilizing one-on-one or small group tutorial.

Students accessing services in a learning support lab will be automatically enrolled in the appropriate noncredit Guidance 250 section. GUID 250 is a noncredit class and will not appear on a student's transcript.

**GUID 530 Job Readiness**

**Transferable:** No

This course is designed to provide a comprehensive, well-organized approach to assist individuals with the identification of occupational choices and the development of job readiness skills necessary to obtain and maintain employment in a competitive or supported work setting. May be repeated twice for credit. This course has the option of a letter grade or credit/no credit.

4441	LAB	BU117	FRANKLIN L	3.40	3.0	TuTh	0945A-1110A	75
------	-----	-------	------------	------	-----	------	-------------	----

**GUID 557 Learning Skills Assessment**

**Transferable:** No

This course provides an assessment of the students' cognitive/perceptual abilities and basic skills academic achievement. The assessment results are used to determine the students' eligibility for Learning Disabilities Services, to develop individual educational plans, and/or to improve the students' understanding of their own learning strengths and weaknesses. The assessment is conducted on a one-to-one basis by appointment. Units earned in this course do not count toward the associate degree and/or certificate requirements. This is a credit/no credit course.

4442	LAB	LI117	FRIEDMAN M STAFF	1.00	.5	day-time	see instructor	2 31
------	-----	-------	---------------------	------	----	----------	----------------	------

**GUID 558 Learning Skills Laboratory**

**Advisory:** Completion of Guidance 557 or demonstrated academic deficit.  
**Transferable:** No

The Learning Skills Laboratory is designed to assist students who are eligible to receive Learning Disabilities Services and/or have demonstrated academic deficits. The course content is individualized and based on Individual Educational Plans and Educational Contracts which are developed for each student. Students receive supplemental instruction, academic support, and learning strategy suggestions appropriate for their individual cognitive, perceptual, and academic strengths and weaknesses. Units earned do not count towards the associated degree and/or certificate requirements. This is a credit/no credit course.

4443	LAB	LI116	FRIEDMAN M STAFF	3.40	1.0	day-time	see instructor	12 31
4444	LAB	LI116	FRIEDMAN M STAFF	6.80	2.0	day-time	see instructor	12 31
4445	LAB	LI116	FRIEDMAN M STAFF	1.70	.5	day-time	see instructor	12 31

Sect. Type Room Instructor Hrs. Units Days Begin-End Footnotes

**GUID 561 Writing Skills**

**Advisory:** Completion of Guidance 557 or demonstrated deficit in written language achievement.  
**Transferable:** No

This course is designed to teach basic writing skills to students who have demonstrated difficulty mastering written language and who are eligible to receive Learning Disability Services. Material is presented in a concrete, multi-sensory manner, and the class includes opportunity for immediate practice, repetition, and review. The course content includes grammar, sentence structure, and punctuation. Units earned do not count toward the associate degree and/or certificate requirements.

4446	LAB	BU117	MARINGER J	2.20	1.0	TuTh	1120A-1245P	12
------	-----	-------	------------	------	-----	------	-------------	----

**GUID 562 Directed Study Lab in Arithmetic**

**Corequisite:** Concurrent enrollment in MATH 400.

**Advisory:** Completion of GUID 557 and/or a demonstrated deficit in arithmetic.  
**Transferable:** No

This course is designed for students who have demonstrated difficulty in mastering arithmetic and who are eligible to receive Learning Disability Services. Course content parallels Mathematics 400. Material is presented in a concrete, multi-sensory manner, and the lab allows opportunity for immediate practice, questions, repetition, and review. Units earned do not count toward the associate degree and/or certificate requirements. This is a credit/no credit course.

4447	LAB	SS216	BURGMAN,L	3.40	1.0	TuTh	1120A-1245P	12
------	-----	-------	-----------	------	-----	------	-------------	----

**GUID 563B Directed Study Lab in Algebra**

**Corequisite:** Concurrent enrollment in MATH 205B is required.

**Advisory:** Completion of GUID 557 or demonstrated deficit in mathematics.  
**Transferable:** No

This course is designed for students who have demonstrated difficulty mastering elementary algebra and who are eligible to receive Learning Disability Services. Course content parallels Mathematics 205B. Material is presented in a concrete, multi-sensory manner, and the lab allows opportunity for immediate practice, questions, repetition, and review. This is a credit/no credit course.

4448	LAB	APE121 APE120	FRIEDMAN M FRIEDMAN M	4.50	1.0	MW	1120A-1245P	12
------	-----	------------------	--------------------------	------	-----	----	-------------	----

**GUID 564 Directed Study Lab in Pre-Algebra**

**Corequisite:** Concurrent enrollment in MATH 402.

**Advisory:** Completion of Guidance 557 and/or a demonstrated deficit in Mathematics.  
**Transferable:** No

This course is designed for students who are eligible to receive Learning Disability Services and/or who have demonstrated difficulty in mastering pre-algebra. The course content parallels Mathematics 402. The material is presented in a concrete, multi-sensory manner, and the lab environment allows opportunity for immediate practice questions, repetition and review. Units earned do not count towards the associate degree and/or certificate requirements. This is a credit/no credit course.

4449	L/L	BU117	BURGMAN,L	3.40	1.0	MW	1120A-1245P	12
------	-----	-------	-----------	------	-----	----	-------------	----

Sect. Type Room Instructor Hrs. Units Days Begin-End Footnotes

## HEALTH EDUCATION

### HE 1 Health Education

**Advisory:** Eligible for English 250 and English 260.  
**Transferable:** CSU; UC; CSU-GE: E2; GAV-GE: E2

This course focuses on attaining individual awareness, critical-thinking skills and self-responsibility relating to personal health. The interaction of individual physical, psychological, social, emotional, spiritual and environmental factors in determining health status is developed through integration of major concepts. This course has the option of a letter grade or credit/no credit.

4450 LEC LS104 DODD S 3.40 3.0 TuTh 0945A-1110A

### HE 2 Human Sexuality

**Advisory:** Eligible for English 250 and English 260  
**Transferable:** CSU; UC; CSU-GE: E2; GAV-GE: E2

Assists students in gaining increased knowledge, appreciation, and respect for their own sexuality, as well as others. Approved by the Board of Registered Nursing for 54 hours of continuing education credit (Provider #00892).

4451 ONLINE QUATRE S 3.40 3.0 DHR 0000-0000 38  
 This online class will be delivered entirely over the internet. After enrolling, start the class by going to <http://www.gavilan.edu/disted/>, click on your class link, and email the instructor at [squatre@gavilan.edu](mailto:squatre@gavilan.edu). Students who have not begun the class or contacted the instructor by 5 pm on Monday, February 5 will be dropped from the class.



## HISTORY

### HIST 1 United States History through Reconstruction

**Advisory:** Eligible for English 250 and English 260.  
**Transferable:** CSU; UC; CSU-GE: C2, D6; IGETC: 3B, 4F, 7B; GAV-GE: C2, D2; CAN: HIST 8, HIST SEQ. B

History of the United States from the time before European contact with the Americas through Reconstruction. Emphasis will be placed on distinctive patterns of political, economic, social, intellectual, and geographic developments within their global context. At the conclusion of the course, the student should understand major themes in the history of the United States, and be able to explain various ways in which ideas about federal vs. state power, ethnicity, class, and gender divisions have influenced the nation's development. This course has the option of a letter grade or credit/no credit.

4452 LEC MHG4 MOSHER C 3.40 3.0 MW 0810A-0935A  
 Above class meets at Morgan Hill Community site  
 4453 LEC SS214 HALPER L 3.40 3.0 TuTh 1120A-1245P  
 4454 LEC SS214 HALPER L 3.40 3.0 MW 1255P-0220P  
 4455 LEC SS210 HALPER L 3.40 3.0 TuTh 1255P-0220P

### HIST 2 United States History Reconstruction to the Present

**Advisory:** Eligible for English 250 and English 260.  
**Transferable:** CSU; UC; CSU-GE: C2, D6; IGETC: 3B, 4F, 7B; GAV-GE: C2, D2; CAN: HIST 10, HIST SEQ. B

History of the United States from Reconstruction to the present. Emphasis will be placed on distinctive patterns of political, economic, social, intellectual, and geographic developments within their global context. At the conclusion of the course, the student should understand major themes in the history of the United States, and be able to explain various ways in which ideas about federal vs. state power, ethnicity, class, and gender divisions have influenced the nation's development. This course has the option of a letter grade or credit/no credit.

4456 LEC SS205 WOOD D 3.40 3.0 MW 0810A-0925A  
 4457 LEC MHG10 MOSHER C 3.40 3.0 MW 0945A-1110A  
 Above class meets at Morgan Hill Community site  
 4458 LEC SS210 LUNA E 3.40 3.0 TuTh 0945A-1110A  
 4459 LEC SS210 LUNA E 3.40 3.0 MW 1255P-0220P  
 6120 LEC HOL2 LUNA E 3.40 3.0 W 0630P-0940P  
 Above class meets at the Hollister Briggs site

Sect. Type Room Instructor Hrs. Units Days Begin-End Footnotes



### HIST 4A History of World Societies, Before 1500

**Advisory:** English 250 and English 260.  
**Transferable:** CSU; UC; CSU-GE: C2, D6; IGETC: 3B, 4F; GAV-GE: C2, D2

A study of major elements in the development of and interactions between world societies, from the first organization of community to the dawn of the Renaissance. Students will comparatively analyze social, cultural, geographic, economic, demographic, technological, environmental, and political developments that moved humans from nomadic to agri-technological and urban lives. This course has the option of a letter grade or credit/no credit.

6121 LEC SS210 HALPER L 3.40 3.0 Tu 0600P-0910P

### HIST 6 Women's Lives in Recent United States History

**Advisory:** English 250  
**Transferable:** CSU; UC; CSU-GE: C2, D4, D6; IGETC: 3B, 4F; GAV-GE: C2,

The class examines the construction of womanhood in the US during the twentieth century. The class explores the effects of gender, ethnicity, class, and sexual orientation upon women's experiences. Students will study the contributions of various individual women and groups of women in creating the modern United States, and will analyze social, political, economic, and cultural forces affecting women to both join and resist movements for social change. Students will also learn to apply contemporary feminist theory to traditional historical approaches.

4460 LEC SS110 WOOD D 3.40 3.0 MW 0945A-1110A

## STAFF Profile



### Judy Rodriguez:

I am the instructional site manager for the Gavilan College Hollister Site, which is located in the Briggs Building on Fourth and San Benito Street in Hollister. I am a life-long resident of Hollister, speak English and Spanish, and have worked at Gavilan College for nine and half years.

My doors are always open to students who need help filling out their admission application or financial aid paperwork. Being part of the first generation in my family to attend college, I remember how helpful people were when I was entering college. I want students to have that same experience when they come into my office. It is true that we learn by example; I like to think that being positive toward students will, in return, help them feel positive towards their education.

Gavilan College Hollister currently offers Academic Counseling once a month, Career Transfer Center Services and Cal-works. We also offer an ESL program. As the youngest of eight children, my parents often needed me to act as a translator, so I have a great appreciation for this program. It gives students the opportunity to better themselves in their communities.

Prior to working for Gavilan, I worked at San Benito High School and San Andreas High School. After receiving my Associate's Degree in Business, I realized that my place was in education where I could help students achieve their academic dreams. I believe in service with a smile.

In the future, as the number of Gavilan students from Hollister grows, we plan to expand the number of student services and courses we offer locally so that students will be able reach their academic goals in the same city in which they work and live.



Sect. Type Room Instructor Hrs. Units Days Begin-End Footnotes

## HIST 7B History of Western Civilization

**Advisory:** Eligible for English 250 and English 260.

**Transferable:** CSU; UC; CSU-GE: C2; IGETC: 3B; GAV-GE: C2; CAN: HIST 4, HIST SEQ. A

A study of major elements in western heritage from Renaissance Europe to the present. Emphasis is on ideas, attitudes and institutions basic to western civilization of enduring interest.

4461 LEC SS205 KIERD 3.40 3.0 TuTh 1255P-0220P

## HIST 12 Cultural History of the Mexican American

**Advisory:** Eligible for English 250 and English 260.

**Transferable:** CSU; UC; CSU-GE: C2, D3, D6; IGETC: 4F, 3B; GAV-GE: D2,

The Mexican American experience as influenced by society in the United States. Emphasis will be on the historical and contemporary contributions made by the Indian, Spanish, Mexican, and Mexican American. Emphasis will also be on the social, economic, and political milieu of the Mexican American within the context of the American society. This course has the option of a letter grade or credit/no credit.

4462 LEC SS210 LUNA E 3.40 3.0 MW 0945A-1110A

## HIST 21 Ancient Americas: A History through Art

**Advisory:** Eligible for English 250.

**Transferable:** CSU; UC; CSU-GE: C1, C2; IGETC: 3A; GAV-GE: C2, F

A critical survey of history through the arts of pre-Columbian natives of North, Central and South America. The course will cover major societies and events from the appearance of major civilizations through the initial colonization efforts of European nations. Due to the distinct history of the Americas, this course uses the arts - architecture, sculpture, ceramics and painting, among others - of ancient societies as a primary source material. This course has the option of a letter grade or credit/no credit. This course is also listed as ART 21.

4463 LEC SS205 LUNA E 3.40 3.0 TuTh 0230P-0355P 25

## HUMANITIES

## HUM 4 Introduction to American Cinema

**Advisory:** English 440

**Transferable:** CSU; UC; CSU-GE: C2; IGETC: 3B; GAV-GE: C2

This introductory course in film studies is a survey of the American film industry as an art form, as an industry, and as a system of representation and communication. The course explores how Hollywood films work technically, aesthetically, and culturally to reinforce and challenge America's national self-image.

6519 TV/LEC SS214 RICHARDS G 3.40 3.0 Th 0630P-0940P 60



Course delivery is through Gavilan Channel 18, Morgan Hill MHAT Channel 18 or video tape (\$25 refundable security deposit required payable to the instructor + \$22 materials fee payable at registration.) This telecourse will have three required on-campus meetings: Thursdays, Feb. 1, March 22 and May 24, 2007. Orientation for the course will be provided at the first class meeting.

## HUM 10 Approaches to Contemporary Film

**Advisory:** Eligibility for English 250 and 260.

**Transferable:** CSU; UC; CSU-GE: C1, C2; IGETC: 3B; GAV-GE: C1, C2

Approaches to Contemporary Film examines theories of film criticism as they apply to films from 1960 to the present. Students learn technical, visual, classical, historical, cultural, ideological, and aesthetic approaches to film and sample from a representative list of foreign and domestic movies. Special emphasis is given to new voices from non-American sources and to emerging voices in American cinema.

4464 LEC SS214 RICHARDS G 3.40 3.0 MW 1120A-1245P

4465 LEC SS214 RICHARDS G 3.40 3.0 TuTh 1255P-0220P

Sect. Type Room Instructor Hrs. Units Days Begin-End Footnotes

## HUM 23 Independent Study

**Required:** The study outline prepared by the student and the instructor must be filed with the department and the dean.

**Transferable:** CSU

Designed to afford selected students specialized opportunities for exploring areas at the independent study level. The courses may involve extensive library work, research in the community, or special projects. May be repeated until six units of credit are accrued. This course has the option of a letter grade or credit/no credit.

4466 IND HU111 RICHARDS G 3.40 1.0 DHR 0000-0000 22

## Information Science: see CSIS

## JAPANESE

## JPN 1A Elementary Japanese

**Transferable:** CSU; UC; CSU-GE: C2; GAV-GE: C2

Beginning course with emphasis on understanding and speaking Japanese; introduction to reading and writing Japanese. This course will also introduce students to Japanese culture and institutions. This course has the option of a letter grade or credit/no credit.

4627 L/L HU104 SAKAI T 5.60 5.0 MW&2.8 1255P-0325P

## JPN 1B Elementary Japanese

**Prerequisite:** Japanese 1A or equivalent.

**Transferable:** CSU; UC; CSU-GE: C2; IGETC: 6A; GAV-GE: C2

Continue Japanese 1A with an emphasis on understanding, speaking, reading, and writing Japanese. This course will continue to introduce students to Japanese culture and institutions. This course has the option of a letter grade or credit/no credit.

6523 L/L SS110 SAKAI T 5.60 5.0 TuTh&2.8 0530P-0800P 20



## JPN 23 Independent Study

**Required:** The study outline prepared by the student and the instructor must be filed with the department and the dean.

**Transferable:** CSU

Designed to afford selected students specialized opportunities for exploring areas at the independent study level. The course may involve extensive library work, research in the community, or special projects. May be repeated until six units of credit are accrued. This course has the option of a letter grade or credit/no credit.

4629 IND SS110 SAKAI T 6.80 2.0 DHR 0000-0000

## Don't forget

A counselor's signature is required if you take over 17.99 units (spring/fall) or over 5.99 units (summer).

You do not need a counselor's signature to register for a class with a prerequisite that was successfully completed at Gavilan.

Sect. Type Room Instructor Hrs. Units Days Begin-End Footnotes

**JOURNALISM**

**JOUR 10 Mass Media and Society**

**Advisory:** English 250, English 260.

**Transferable:** CSU; UC; CSU-GE: C2, D0; IGETC: 4J; GAV-GE: C2, D2; CAN: JOUR 4

This course helps students understand the 20th century revolution in mass media by focusing on the history, economics and social impact of the newspaper, book publishing, magazine, film, television, public relations, advertising and music industries. Students will study audience, propaganda and mass communication theory; and discuss new technology, ethnic media in the United States, ethical issues and attempts to regulate or control the media. Honors students will complete more in-depth analysis of media issues and will finish a media-related research project. This course is also listed as SOC 10. This course has the option of a letter grade or credit/no credit.

4604 LEC AL101 VILLARREALA 3.40 3.0 TuTh 1255P-0220P

**JOUR 18A Working on the Newspaper**

**Advisory:** Eligible for English 1A. Typing ability.

**Transferable:** CSU; GAV-GE: C1

Students interview, write, photograph and do computer assisted design and graphics for the college newspaper, the Gavilan Press. In doing this, they provide the community with an important first amendment forum, learn and educate about the first amendment rights and responsibilities, and acquire journalistic skills, ethics, and habits.

4605 LAB HU106 GUERRAZZI D 2.30 2.0 MW 1120A-1225P 1

4606 LAB HU106 GUERRAZZI D 5.70 3.0 MW 1120A-0150P 1

4607 LAB HU106 GUERRAZZI D 5.70 4.0 MW&3.4 1120A-0150P 1

4608 LAB HU106 GUERRAZZI D 5.70 5.0 MW&6.8 1120A-0150P 1

**JOUR 18B Working on the Newspaper**

**Advisory:** Journalism 18A.

**Transferable:** CSU; GAV-GE: C1

Students interview, write, photograph and do computer assisted design and graphics for the college newspaper, the Gavilan Press. In doing this, they provide the community with an important first amendment forum, learn and educate about the first amendment rights and responsibilities and acquire journalistic skills, ethics and habits.

4609 LAB HU106 GUERRAZZI D 2.30 2.0 MW 1120A-1225P 1

4610 LAB HU106 GUERRAZZI D 5.70 3.0 MW 1120A-0150P 1

4611 LAB HU106 GUERRAZZI D 5.70 4.0 MW&3.4 1120A-0150P 1

4612 LAB HU106 GUERRAZZI D 5.70 5.0 MW&6.8 1120A-0150P 1

**JOUR 18C Working on the Newspaper**

**Advisory:** Journalism 18B.

**Transferable:** CSU; GAV-GE: C1

Students interview, write, photograph and do computer assisted design and graphics for the college newspaper, the Gavilan Press. In doing this, they provide the community with an important first amendment forum, learn and educate about the first amendment rights and responsibilities and acquire journalistic skills, ethics and habits.

4613 LAB HU106 GUERRAZZI D 2.30 2.0 MW 1120A-1225P 1

4614 LAB HU106 GUERRAZZI D 5.70 3.0 MW 1120A-0150P 1

4615 LAB HU106 GUERRAZZI D 5.70 4.0 MW&3.4 1120A-0150P 1

4616 LAB HU106 GUERRAZZI D 5.70 5.0 MW&6.8 1120A-0150P 1



**HIST 4A**

**History of World Societies, Before 1500**



Study the development of and interactions between world societies, from the first organization of community to the dawn of the Renaissance.

*This course satisfies the following requirements:*

*Areas C or D of the Gavilan AA/AS Degree and the transfer requirement for CSU, and Area 3-B requirement under the IGETC pattern for transfer to CSU or UC.*

**STUDENT Profile**



**Tim Holliday:**

As a returning student, I have spent the last couple of years deciding what I wanted to do with my life. With help from Gavilan instructors and the Disability Resource Center, I have continued working towards my educational goals in pursuit of a career. When I first began at Gavilan, I majored in Computer Networking.

While taking Spanish with Mr. Albert Marquez, he asked me to run the sound board for his Music Ensemble class. Though I had very little experience, I got hooked on sound editing and production. With Mr. Marquez leading Bach to Blues, he eventually asked me to run the sound board for the annual event. After working with Mr. Marquez, alongside Art Juncker and the Music Ensemble class, I changed my major to Digital Media. Since summer 2006, I've been an active volunteer for CMAP and GavTV and continue to be involved in Bach to Blues along with other campus and community events.

**Footnotes contain valuable information pertaining to your class selection. Footnotes follow class listings.**

Sect. Type Room Instructor Hrs. Units Days Begin-End Footnotes

Sect. Type Room Instructor Hrs. Units Days Begin-End Footnotes

**JOUR 18D Working on the Newspaper**

Advisory: Journalism 18C.

Transferable: CSU; GAV-GE: C1

Students interview, write, photograph and do computer assisted design and graphics for the college newspaper, the Gavilan Press. In doing this, they provide the community with an important first amendment forum, learn and educate about the first amendment rights and responsibilities and acquire journalistic skills, ethics and habits.

4617	LAB	HU106	GUERRAZZID	2.30	2.0	MW	1120A-1225P	1
4618	LAB	HU106	GUERRAZZID	5.70	3.0	MW	1120A-0150P	1
4619	LAB	HU106	GUERRAZZID	5.70	4.0	MW&3.4	1120A-0150P	1
4620	LAB	HU106	GUERRAZZID	5.70	5.0	MW&6.8	1120A-0150P	1

**JOUR 22 Field Work and Service**

Required: Learning contracts must be filled out and signed by the student and the supervising instructor.

Transferable: CSU; GAV-GE: C1

Supervised field work within the college and with local agencies. Students serve in useful group activities in leadership roles prescribed for them by faculty or community agencies. A maximum of six units may be completed. This is a credit/no credit course.

4621	IND	HU107	GUERRAZZID	3.40	1.0	TBA	0000-0000	21
------	-----	-------	------------	------	-----	-----	-----------	----

**JOUR 23 Independent Study**

Required: The study outline prepared by the student and the instructor must be filed with the department and the dean.

Transferable: CSU; GAV-GE: C1

Designed to afford selected students specialized opportunities for exploring areas at the independent study level. The courses may involve extensive library work, research in the community, or special projects. May be repeated until six units of credit are accrued. This course has the option of a letter grade or credit/no credit.

4622	IND	HU106	GUERRAZZID	6.40	2.0	DHR	0000-0000	22
------	-----	-------	------------	------	-----	-----	-----------	----

**JOUR 190 Occupational Work Experience/Journalism**

Required: Enrollment in a minimum of seven (7) units, including Cooperative Work Experience, during regular semesters; enrollment in at least one other class in summer session.

Transferable: CSU

The application of learned theory, knowledge, and skills to a practical job setting related to the student's educational/occupational goal. Employment must be directly related to the student's college educational/occupational goal. Periodic interviews of the students and employers or their representatives will be required. Each student shall be assisted in the development of individualized performance objectives, toward which the learning experience shall be directed.

4623	WEX	BU125	KERR L	5.60	1.0	DHR	0000-0000
4624	WEX	BU125	KERR L	11.30	2.0	DHR	0000-0000
4625	WEX	BU125	KERR L	16.90	3.0	DHR	0000-0000
4626	WEX	BU125	KERR L	22.50	4.0	DHR	0000-0000

**Don't go to the wrong city**

MHG = Morgan Hill Community Center site

HOL = Hollister Briggs Building site

**JPA Fire Technology and JPA Law Enforcement**

see ad below:

**Careers in**  
 Law Enforcement • Fire Technology  
 Probation Officer • Dispatcher  
 Corrections Officer • Juvenile Hall Counselor

Gavilan College is a member of the South Bay Regional Public Safety Training consortium. This consortium is funded by all colleges regionally to provide vocational specific training which may require special facilities, special training conditions or is presented outside of the schedules of regular college classes. For more information call 408-270-6458.

**Law Enforcement: see also Administration of Justice**

**LIBRARY**

**LIB 6 Web Page Authoring I**

Advisory: CSIS 1 or CSIS 2 or CSIS/LIB 3 advised.

Transferable: CSU; GAV-GE: E2

A introduction to using Hypertext Mark-Up Language (HTML) and Extensible HTML (XHTML) to create web pages which can be unloaded and displayed on the World Wide Web. Students will use HTML/XHTML to create web pages with text in various sizes and colors, links to other sites, background color or patterns, graphics, tables, and mailto links. Principles of design and color as they apply to screen presentations will be included. This course has the option a letter grade or credit/no credit. May be repeated three times for credit. Also listed as CSIS 6 and DM 6.

4630 ONLINE HOWELL J 4.60 2.0 DHR 0000-0000 11 25 38  
 01/31/07 - 03/24/07 This online class will be delivered entirely over the internet. After enrolling, start the class by going to <http://www.gavilan.edu/disted/>, click on your class link, and email the instructor at [jhowell@gavilan.edu](mailto:jhowell@gavilan.edu). Students who have not begun the class or contacted the instructor by 5 pm on Monday, February 5 will be dropped from the class.

4631 ONLINE VENABLE E 4.60 2.0 DHR 0000-0000 11 25 38  
 03/26/07 - 05/21/07 This online class will be delivered entirely over the internet. After enrolling, start the class by going to <http://www.gavilan.edu/disted/>, click on your class link, and email the instructor at [smeader@gavilan.edu](mailto:smeader@gavilan.edu). Students who have not begun the class or contacted the instructor by 5 pm on the third day of the class, will be dropped from the class.

**LIB 140 Online Health Research**

Transferable: CSU

A beginning course on how to find reliable and current health-related information, using the internet and other electronic resources.

4632 ONLINE MEADERS S 4.60 2.0 DHR 0000-0000 11 25 38  
 03/26/07-05/21/07 This online class will be delivered entirely over the internet. After enrolling, start the class by going to <http://www.gavilan.edu/disted/>, click on your class link, and email the instructor at [smeader@gavilan.edu](mailto:smeader@gavilan.edu). Students who have not begun the class or contacted the instructor by 5 pm on the third day of the class, will be dropped from the class.

**Mass Media: see JOUR 10**

Sect. Type Room Instructor Hrs. Units Days Begin-End Footnotes

**MATHEMATICS**

**MATH 1A Single-Variable Calculus and Analytic Geometry**

**Prerequisite:** Mathematics 10 or Mathematics 8B with a grade of 'C' or better.  
**Transferable:** CSU; UC; CSU-GE: B4; IGETC: 2A; GAV-GE: B4; CAN: MATH 18, MATH SEQ. B  
 Limits and continuity, analyzing the behavior and graphs of functions, derivatives, implicit differentiation, higher order derivatives, related rates and optimization word problems, Newton's Method, Fundamental Theorem of Calculus, and definite and indefinite integrals.

6132	LEC	CH109	JUKLH	4.50	4.0	MW	0630P-0835P	1
------	-----	-------	-------	------	-----	----	-------------	---

**MATH 1B Single-Variable Calculus and Analytic Geometry**

**Prerequisite:** Mathematics 1A with a grade of 'C' or better.  
**Transferable:** CSU; UC; CSU-GE: B4; IGETC: 2A; GAV-GE: B4; CAN: MATH 20, MATH SEQ. B  
 This course is a standard second semester Calculus course covering methods of integration, applications of the integral, differential equations, parametric and polar equations, and sequences and series.

4639	LEC	PH102	DACHKOVA E	4.50	4.0	F	1250P-0150P	1 15
			DACHKOVA E			MW	1255P-0220P	

**MATH 1C Multivariable Calculus**

**Prerequisite:** Mathematics 1B with a grade of 'C' or better.  
**Transferable:** CSU; UC; CSU-GE: B4; IGETC: 2A; GAV-GE: B4; CAN: MATH 22, MATH SEQ. C  
 A standard third semester Calculus course covering functions of several variables, vectors, surfaces, vector-valued functions, partial derivatives, multiple and line integrals, Green's Theorem, Stokes' Theorem, and the Divergence Theorem.

4640	LEC	PH102	DWYER M	4.50	4.0	TuTh	0230P-0435P	15
------	-----	-------	---------	------	-----	------	-------------	----

**MATH 5 Introduction to Statistics**

**Prerequisite:** Mathematics 233 with a grade of 'C' or better.  
**Transferable:** CSU; UC; CSU-GE: B4; IGETC: 2A; GAV-GE: B4; CAN: STAT 2  
 Descriptive analysis and presentation of either single-variable data or bivariate data, probability distributions, normal probability distributions, sample variability, statistical inferences involving one and two populations, analysis of variance, linear correlation and regression analysis. Statistical computer software will be extensively integrated as a tool in the description and analysis of data.

4641	LEC	SS206	GUENTHER J	4.40	3.0	TuTh	0810A-0935A	1
		PH101	GUENTHER J			F	0810A-0910A	
4642	LEC	LS101	BUTTERWORTH	4.40	3.0	TuTh	1120A-1245P	1
		PH101	BUTTERWORTH			F	1140A-1240P	
4643	LEC	PH103	JUKLH	4.40	3.0	MW	0230P-0435P	
4644		ONLINE	HUBBARD M	4.40	3.0	DHR	0000-0000	38 53

 This online class will be delivered primarily over the internet. After enrolling, start the class by going to <http://www.gavilan.edu/disted/>, click on your class link, and email the instructor at [mhubbard@gavilan.edu](mailto:mhubbard@gavilan.edu). Students who have not begun the class or contacted the instructor by 5 pm on Monday, February 5 will be dropped from the class. Class will meet on Saturday, Feb. 3, from 12-2 pm in PH 103 plus three additional meetings - dates to be announced.

6133	LEC	LS101	LITTIG A	4.40	3.0	Tu	0630P-0730P	1 15
		PH101	LITTIG A			Tu	0735P-0840P	
		LS101	LITTIG A			Th	0630P-0835P	

6134 LEC MHG4 VIARENGO A 4.40 3.0 MW 0630P-0835P 1  
 Above class meets at Morgan Hill Community site

**Be Aware**

If your goal is a MULTIPLE SUBJECT CREDENTIAL, you may need MATH 12, Math for Elementary Teachers.



**Make Something Happen!**

**Learn Something New!**

- ◆ Earn units toward a Media Arts Degree
- ◆ Learn new writing, research and design skills
- ◆ Get published and build a portfolio of your work
- ◆ Gain work experience that will help you land a good job
- ◆ Become part of a team
- ◆ Support free speech at Gavilan College!

**JOUR 10 Mass Media & Society**

*What impact do mass media have on our society and on our world?*

**JOUR 18A-D Working on the Newspaper**

*Become a staff member of The Gavilan Press, Gavilan's independent student newspaper.*

 **Tutoring Center**  
[www.gavilan.edu/tutor](http://www.gavilan.edu/tutor) 408-848-4838  
 Located in LI 116



**Free tutoring is available in a variety of subjects.**

*Work with a peer tutor and fellow students to develop a better understanding of course content.*

**Fall/Spring Semester:**

Mon. - Thurs.: 8:00 a.m. - 7:45 p.m.  
 Fri.: 8:00 a.m. - 4:00 p.m.

**Summer Session:**

Call for hours

Debbie Roderick, Tutoring Program Coordinator

Sect. Type Room Instructor Hrs. Units Days Begin-End Footnotes

## MATH 6 Calculus for Business/Social Science

**Prerequisite:** Mathematics 233 with a grade of 'C' or better.

**Transferable:** CSU; UC; CSU-GE: B4; IGETC: 2A; GAV-GE: B4; CAN: MATH 34

This course applies the fundamental principles and techniques of calculus to problems in business, economics, the life sciences and the social sciences. Topics will include limits, and differentiation and integration of linear, quadratic, polynomial, exponential and logarithmic functions. This course is not intended for students majoring in engineering, the physical sciences or math. Using a calculator is required. Graphing calculator is recommended.

4645 LEC PH102 LOCKHART L 3.40 3.0 TuTh 0810A-0935A

## MATH 7 Finite Mathematics

**Prerequisite:** Mathematics 233 with a grade of 'C' or better.

**Transferable:** CSU; UC; CSU-GE: B4; IGETC: 2A; GAV-GE: B4; CAN: MATH 12

Systems of linear equations and matrices, introduction to linear programming, finance, counting techniques and probability, properties of probability and applications of probability.

4646 LEC PH102 DRESCH M 3.40 3.0 TuTh 1255P-0220P 1 15

## MATH 8A First Half of Precalculus

**Prerequisite:** Mathematics 233 with a grade of 'C' or better.

**Transferable:** CSU; UC; CSU-GE: B4; IGETC: 2A; GAV-GE: B4

Math 8A prepares the student for the study of calculus by providing important skills in algebraic manipulation, interpretation, and problem solving at the college level. Topics will include basic algebraic concepts, complex numbers, equations and inequalities of the first and second degree, functions, and graphs, linear and quadratic equations, polynomial functions, exponential and logarithmic functions, systems of equations, matrices and determinants, right triangle trigonometry, and the Law of Sines and Cosines.

4647 LEC LS101 WAGMAN K 4.50 4.0 F 0920A-1020A 1 15  
WAGMAN K TuTh 0945A-1110A

6135 LEC PH102 STAFF 4.50 4.0 MW 0630P-0835P 1 15

Sect. Type Room Instructor Hrs. Units Days Begin-End Footnotes

## MATH 8B Second Half of Precalculus

**Prerequisite:** Mathematics 8A with a grade of 'C' or better.

**Advisory:** Math 208 Survey of Practical Geometry.

**Transferable:** CSU; UC; CSU-GE: B4; IGETC: 2A; GAV-GE: B4

Math 8B prepares students for the study of calculus by providing important skills in algebraic manipulation, interpretation, and problem solving at the college level. Topics will include trigonometric functions, identities, inverse trigonometric functions, and equations; applications of trigonometry, vectors, complex numbers, polar and parametric equations; conic sections; sequences, series, counting principles, permutations, mathematical induction; analytic geometry, and an introduction to limits.

4648 LEC PH103 DWYER M 4.50 4.0 F 1250P-0150P 15  
SS206 DWYER M MW 1255P-0220P

## MATH 14 Math for the Liberal Arts

**Prerequisite:** Math 233 with a grade of 'C' or better.

**Transferable:** CSU; UC; CSU-GE: B4; IGETC: 2A; GAV-GE: B4

Survey of selected topics from contemporary mathematics to introduce the student to mathematical thinking for the non-specialist. Topics include systems of numeration, algebraic modeling, linear programming, trigonometry, math of finance, probability and statistics, and an introduction to calculus.

6136 LEC LS102 KERCHEVAL S 3.40 3.0 Tu 0600P-0910P 1

## MATH 201A Math for Science and Engineering

**Corequisite:** Enrollment in appropriate section of Math 205 which is part of a learning community.

**Transferable:** No

This course will provide a combination of math study skills, introduction to scientific equipment and technology for mathematics, analysis of data from various branches of science, one or more field trips, investigation of educational plans and program choices at the transfer level.

4649 LEC SS206 DRESCH M 1.00 1.0 F 0920A-1020A

The above class is part of a learning community. You must enroll in corequisite courses. See MATHEMATICS - LEARNING COMMUNITY ad below.

## MATH 201B Math for Science and Engineering

**Corequisite:** Enrollment in appropriate section of Math 233 which is part of a learning community.

**Transferable:** No

This course will provide a combination of math study skills, introduction to scientific equipment and technology for mathematics, collection and analysis of data from various branches of science, one or more field trips, investigation of science careers and program choices at the transfer level.

4650 LEC PH103 DWYER M 1.00 1.0 F 0920A-1020A

The above class is part of a learning community. You must enroll in corequisite courses. See MATHEMATICS - LEARNING COMMUNITY ad below.



## Close Encounters with Math and Science

- Have you ever thought about a career in science, engineering, or math, but doubted your ability to get through the math classes required?
- Are you looking for a supportive environment to help you with your math?
- Have you ever wondered how math applies to real world problems?
- Would you like to gain some hands-on experience with tools and techniques of science?



Then these Learning Communities are for you! Sign up for:

**MATH 233 Intermediate Algebra** sect. 4664 MTuWTh 945A-1055A

**MATH 201B Math for Science & Engineering** sect. 4650 F 920A-1020A

OR

**MATH 205 Elementary Algebra** sect. 4653 MTuWTh 945A-1055A

**MATH 201A Math for Science & Engineering** sect. 4649 F 920A-1020A

For more information about this exciting new program contact math instructor Marlene Dwyer in Ph110, call (408) 848-4897, or email mdwyer@gavilan.edu

Sect. Type Room Instructor Hrs. Units Days Begin-End Footnotes

**MATH 205 Elementary Algebra**

**Prerequisite:** MATH 402 with a grade of 'C' or better or assessment test recommendation.  
**Transferable:** No; GAV-GE: B4

This course is a standard beginning algebra course, including algebraic expressions, linear equations and inequalities in one variable, graphing, equations and inequalities in two variables, integer exponents, polynomials, rational expressions and equations, radicals and rational exponents, and quadratic equations. Mathematics 205, 205A and 205B, and 206 have similar course content. This course may not be taken by students who have completed Mathematics 205B or 206 with a grade of "C" or better. This course may be taken for Mathematics 205B credit (2.5 units) by those students who have successfully completed Mathematics 205A with a grade of "C" or better.

**LEARNING COMMUNITY SECTION:**

4653	LEC	SS206	DRESCH M	5.60	5.0	MTuWTh	0945A-1055A	1
The above class is part of a learning community. You must enroll in corequisite courses. See MATHEMATICS - LEARNING COMMUNITY ad on page 100.								

**OTHER SECTIONS:**

4651	LEC	PH103	DWYER M DWYER M	5.60	5.0	MWF TuTh	0810A-0900A 0810A-0915A	1
Above class meets at Morgan Hill Community site								
4652	LEC	MHG13	KERCHEVAL S	5.60	5.0	MTuWTh	0945A-1055A	1
Above class meets at Morgan Hill Community site								
4654	LEC	HOL6	FULLER G	5.60	5.0	MTuWTh	1120A-1230P	1
Above class meets at the Hollister Briggs site								
4655	LEC	PH103	STAFF	5.60	5.0	MTuWTh	1120A-1230P	1
4656	LEC	CH109	WAGMAN K	5.60	5.0	MTuWTh	1255P-0205P	1
4657	LEC	CH109	WAGMAN K	5.60	5.0	MTuWTh	0230P-0335P	1
6137	LEC	PH103	ARID A	5.60	5.0	M W	0630P-0900P	1
6138	LEC	MHG13	KING K	5.60	5.0	TuTh	0630P-0900P	1
Above class meets at Morgan Hill Community site								

**MATH 205A First Half of Elementary Algebra**

**Prerequisite:** Effective Fall 2005: MATH 402 with a grade of 'C' or better or assessment test recommendation.

**Advisory:** Concurrent enrollment in Guidance 563A is advised.

**Transferable:** No; GAV-GE: B4

This course is the first half of the Elementary Algebra course. It will cover signed numbers, evaluation of expressions, ratios and proportions, solving linear equations, and applications. Graphing of lines, the slope of a line, graphing linear equations, solving systems of equations, basic rules of exponents, and operations on polynomials will be covered.

4658	LEC	SS206	DACHKOVA E	4.50	2.5	MW	1120A-1245P	1
		PH103	DACHKOVA E			F	1140A-1240P	1
4659	LEC	SS206	LOCKHART L	4.50	2.5	TuTh	1255P-0220P	1
			LOCKHART L			F	1250P-0150P	1

**MATH 205B Second Half of Elementary Algebra**

**Prerequisite:** Math 205A with a grade of 'C' or better.

**Advisory:** Concurrent enrollment in Guidance 563B is advised.

**Transferable:** No; GAV-GE: B4

This course contains the material covered in the second half of the Elementary Algebra Course. It will cover factoring, polynomials, solving quadratic equations by factoring, rational expressions and equations, complex fractions, radicals and radical equations, solving quadratic equations by completing the square and the quadratic formula. Application problems are integrated throughout the topics.

4660	LEC	SS206	LOCKHART L LOCKHART L	4.50	2.5	MW	0810A-0935A 0810A-0910A	1
4661	LEC	SS206	LOCKHART L	4.50	2.5	TuTh	1120A-1245P	1
		SS206	LOCKHART L			F	1140A-1240P	1
6139	LEC	SS206	GROVER MJ	4.50	2.5	TuTh	0630P-0835P	1

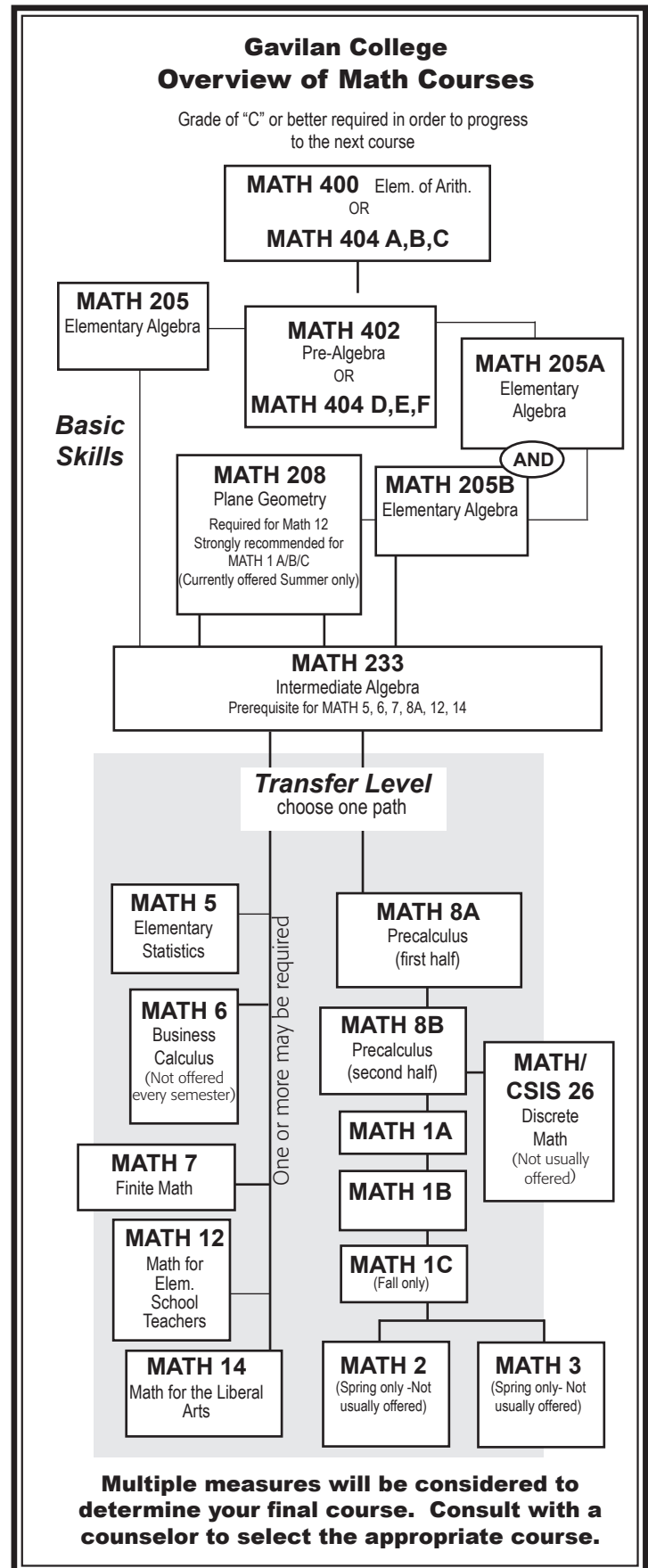

Footnotes contain valuable information pertaining to your class selection. Footnotes follow class listings.

Sect. Type Room Instructor Hrs. Units Days Begin-End Footnotes

**MATH 233 Intermediate Algebra**

**Prerequisite:** Mathematics 205 or Mathematics 205A and 205B or Mathematics 206 with a grade of 'C' or better.

**Transferable:** No; GAV-GE: B4

Review of basic concepts, linear equations and inequalities, graphs and functions, systems of linear equations, polynomials and polynomial functions, factoring, rational expressions and equations, roots, radicals, and complex numbers, solving quadratic equations, exponential and logarithmic functions, and problem solving strategies.

**LEARNING COMMUNITY SECTION:**

4664 LEC PH103 DWYER M 5.60 5.0 MTuWTh 0945A-1055A 1  
 The above class is part of a learning community. You must enroll in corequisite courses. See MATHEMATICS - LEARNING COMMUNITY ad on page 100.

**OTHER SECTIONS:**

4662	LEC	CH109	DRESCH M DRESCH M	5.60 5.0	MWF TuTh	0810A-0900A 0810A-0915A	1
4663	LEC	MHG11	BUTTERWORTH	5.60 5.0	MTuWTh	0945A-1055A	1
Above class meets at Morgan Hill Community site							
4665	LEC	HOL2	GUENTHER J	5.60 5.0	MTuWTh	1120A-1230P	1
Above class meets at the Hollister Briggs site							
4666	LEC	CH109	JUKL H	5.60 5.0	MTuWTh	1120A-1230P	1 15
4667	LEC	PH103	LEER	5.60 5.0	MTuWTh	1255P-0205P	
4668	LEC	SS206	VIARENGO A	5.60 5.0	MTuWTh	0400P-0510P	
6140	LEC	HOL4	BATES R	5.60 5.0	TuTh	0600P-0830P	1
Above class meets at the Hollister Briggs site							
6141	LEC	PH103	LOCKHART L	5.60 5.0	TuTh	0630P-0900P	1

**MATH 400 Elements of Arithmetic**

**Transferable:** No

Essential arithmetic operations, whole numbers, integers, fractions, decimals, ratio, proportion, percent, applications of arithmetic, and critical thinking, as well as math-specific study skills. Units earned in this course do not count toward the associate degree and/or other certain certificate requirements.

4669	L/L	LS103 PH103	DACHKOVA E DACHKOVA E	4.40 3.0	MW F	0945A-1110A 1030A-1130A	1
4670	L/L	LS102	DACHKOVA E DACHKOVA E	4.40 3.0	TuTh F	0945A-1110A 0920A-1020A	1
6142	L/L	SS206	STAFF	4.40 3.0	M W	0630P-0835P	1

**MATH 402 Pre-Algebra**

**Prerequisite:** Completion of Math 400 with a 'C' or better, or assessment test recommendation.

**Transferable:** No

This course covers operations with integers, fractions and decimals and associated applications, percentages, ratio, and geometry and measurement, critical thinking and applications. Elementary algebra topics such as variables, expressions, and solving equations are introduced.

4671	L/L	LS102	FULLER G FULLER G	4.40 3.0	TuTh F	0810A-0935A 0810A-0910A	1
4672	L/L	PH102 CH109	JUKL H JUKL H	4.40 3.0	MW TuTh	0945A-1050A 0945A-1035A	1
4673	L/L	LS102	STAFF STAFF	4.40 3.0	MW F	1255P-0220P 1250P-0150P	1
6143	L/L	PH102	ARID A	4.40 3.0	TuTh	0630P-0835P	1

Sect. Type Room Instructor Hrs. Units Days Begin-End Footnotes

**MATH 404A-G Self-Paced Basic Math**

These classes involve both lecture and hands-on computer components. All sections are open for late registration.

**Transferable:** No

This course is a remedial, modular, self-paced course. Application and critical thinking skills are developed in each module. Module A covers operations with whole numbers, equivalent fractions, multiplying and dividing fractions. Module B covers adding and subtracting fractions, and operations with decimals. Module C covers ratio and proportion, percent, and units of measurement. Module D reviews fractions, decimals, percentages, and covers operations with integers, and working with variables. Module E covers real numbers, fractions, exponents, scientific notation, and order of operations. Module F covers expressions, polynomials, and equations. Module G covers geometric figures, perimeter and area, surface area and volume, triangles and parallelograms, and similar figures. This course has the option of a letter grade or credit/no credit.

**MATH 404A Self-Paced Basic Math**

4674	L/L	PH101	DACHKOVA E	1.30 1.0	Tu Th F	1255P-0225P 1255P-0325P 1250P-0150P	179
------	-----	-------	------------	----------	---------------	---	-----

**MATH 404B Self-Paced Basic Math**

4675	L/L	PH101	DACHKOVA E	1.30 1.0	Tu Th F	1255P-0225P 1255P-0325P 1250P-0150P	179
------	-----	-------	------------	----------	---------------	---	-----

**MATH 404C Self-Paced Basic Math**

4676	L/L	PH101	DACHKOVA E	1.30 1.0	Tu Th F	1255P-0225P 1255P-0325P 1250P-0150P	179
------	-----	-------	------------	----------	---------------	---	-----

**MATH 404D Self-Paced Basic Math**

4677	L/L	PH101	DACHKOVA E	1.30 1.0	Tu Th F	1255P-0225P 1255P-0325P 1250P-0150P	179
------	-----	-------	------------	----------	---------------	---	-----

**MATH 404E Self-Paced Basic Math**

4678	L/L	PH101	DACHKOVA E	1.30 1.0	Tu Th F	1255P-0225P 1255P-0325P 1250P-0150P	179
------	-----	-------	------------	----------	---------------	---	-----

**MATH 404F Self-Paced Basic Math**

4679	L/L	PH101	DACHKOVA E	1.30 1.0	Tu Th F	1255P-0225P 1255P-0325P 1250P-0150P	179
------	-----	-------	------------	----------	---------------	---	-----

**MATH 404G Self-Paced Basic Math**

4680	L/L	PH101	DACHKOVA E	1.30 1.0	Tu Th F	1255P-0225P 1255P-0325P 1250P-0150P	179
------	-----	-------	------------	----------	---------------	---	-----

**Medical Terminology: see Business**

**Have you met the prerequisite?  
It's required!**

Sect. Type Room Instructor Hrs. Units Days Begin-End Footnotes

**MUSIC**

**MUS 1A Music History and Literature**

**Advisory:** Eligible for English 250 and English 260.

**Transferable:** CSU; UC; CSU-GE: C1; IGETC: 3A; GAV-GE: C1; CAN: MUS 8

A survey of the development of music in western civilization including representative composers from the Medieval to the present. Music 1A will study the music and styles from the Medieval to the Romantic period.

4681 ONLINE BENKMAN N 3.40 3.0 DHR 0000-0000 38

This online class will be delivered entirely over the internet. After enrolling, start the class by going to <http://www.gavilan.edu/disted/>, click on your class link, and email the instructor at [nbenkman@gavilan.edu](mailto:nbenkman@gavilan.edu). Students who have not begun the class or contacted the instructor by 5 pm on Monday, February 5 will be dropped from the class.



**MUS 1B Music History and Literature**

**Advisory:** Eligible for English 250 and English 260.

**Transferable:** CSU; UC; CSU-GE: C1; IGETC: 3A; GAV-GE: C1

A survey of the development of music in western civilization including representative composers from the Medieval period to the present. Music 1B will study the music and styles from late Romanticism to the present.

4682 LEC AL101 AMIRKHANIAN 3.40 3.0 MW 0945A-1110A

**MUS 3A Harmony - Theory - Musicianship**

**Advisory:** Must be taken in sequence.

**Transferable:** CSU; UC; CSU-GE: C1; GAV-GE: C1

Fundamentals of music, beginning harmony.

4683 L/L TH130 JUNCKER A 4.50 4.0 TuTh&2.3 0900A-1105A

**MUS 3B Harmony - Theory - Musicianship**

**Advisory:** Must be taken in sequence.

**Transferable:** CSU; UC; GAV-GE: C1

Fundamentals of music, beginning harmony.

4684 L/L TH130 JUNCKER A 4.50 4.0 MW&2.3 0900A-1105A

**MUS 3C Intermediate Harmony - Theory**

**Advisory:** Music 3B

**Transferable:** CSU; UC; GAV-GE: C1

Continuation of Music 3AB. Chromatic harmony, analysis and composition.

4685 L/L TH130 JUNCKER A 4.50 4.0 MW&2.3 0900A-1105A

**MUS 3D Intermediate Harmony - Theory**

**Advisory:** Music 3C

**Transferable:** CSU; UC; GAV-GE: C1

Continuation of Music 3C. Analysis and composition.

4686 L/L TH130 JUNCKER A 4.50 4.0 MW&2.3 0900A-1105A

**MUS 4A Beginning Piano**

**Advisory:** Must be taken in sequence.

**Transferable:** CSU; UC; CSU-GE: C1; GAV-GE: C1

Introduction to music fundamentals and keyboard technique. Development of beginning keyboard skills including note reading in bass and treble clef, fingering, rhythm, key signatures, primary chords and inversions.

4687 L/L TH130 AMIRKHANIAN 4.60 3.0 TuTh 0900A-1105A

4688 L/L TH130 AMIRKHANIAN 4.60 3.0 MW 1120A-0125P

6144 L/L TH130 MELLO S 4.60 3.0 M&2.3 0630P-0940P

**Footnotes contain valuable information pertaining to your class selection. Footnotes follow class listings.**

**FACULTY**

*Profile*



**Maria Amirkhanian:**

Award winning concert pianist, Maria Amirkhanian, comes to Gavilan College with a wealth of teaching experience backed by a lifetime of live musical performances that have spanned the globe.

Growing up in a musical family, Dr. Amirkhanian started playing piano at an early age. At the tender age of five, she began her studies at the Tchaikovsky School of music in the now former Soviet Union. Coming to the United States in the early 90's, she attended CSU, Fresno and received her Master's degree. She later completed her doctorate at the Moscow Conservatory of Music in Russia.

Take a music class with Dr. Amirkhanian at Gavilan College, or come see her play live at the Gavilan College "Bach to Blues" concert on March 9 or March 17 with the South Valley Symphony!

**FREE TUTORING!**

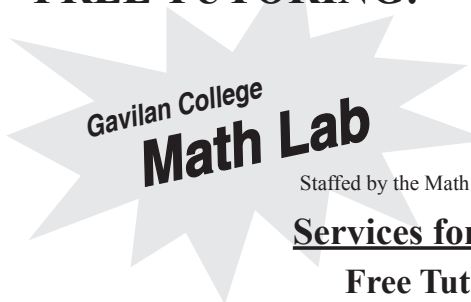

Gavilan College  
**Math Lab**

Staffed by the Math Department

**Services for Gavilan Students:**

**Free Tutoring for MATH**  
**Free Computer Assistance**

**PH101**

For daily schedule or for free Math downloads, check our website - <http://www.gavilan.edu/mathlab/>

**THERE'S A TV STATION AT GAVILAN**



**Community Media Access Partnership (CMAP) manages the four community TV channels in Gilroy, Hollister and San Juan Bautista. Any resident can submit a video to air, or you can learn how to use CMAP's video equipment and make a TV show.**

**Channel 17 City View**

**Channel 18 GavTV**

**Channel 19 EdTV**

**Channel 20 Public Access**

**INTERESTED? CHECK OUT OUR WEBSITE: [WWW.MYCMAP.ORG](http://WWW.MYCMAP.ORG) OR DROP BY OUR FACILITY IN L-139!**



Sect. Type Room Instructor Hrs. Units Days Begin-End Footnotes

**MUS 4B Beginning Piano**

Advisory: Music 4A  
Transferable: CSU; UC; GAV-GE: C1

Continuation of Music 4A.

4689	L/L	TH130	AMIRKHANIAN	3.30	2.0	MW	1255P-0220P
6145	L/L	TH130	MELLO S	3.30	2.0	M	0630P-0940P

**MUS 5A Intermediate Piano**

Advisory: Music 4B  
Transferable: CSU; UC; GAV-GE: C1

Development of intermediate keyboard skills through means of scales, chords, and technical studies. Continuation of music fundamentals and beginning keyboard harmony; introduction of easier classical and standard piano literature.

4690	L/L	TH130	AMIRKHANIAN	3.30	2.0	MW	1255P-0220P
6146	L/L	TH130	MELLO S	3.30	2.0	M	0630P-0940P

**MUS 5B Intermediate Piano**

Advisory: Music 5A  
Transferable: CSU; UC; GAV-GE: C1

Development of intermediate keyboard skills through means of scales, chords and technical studies. Continuation of music fundamentals and beginning keyboard harmony; introduction of easier classical and standard piano literature.

4691	L/L	TH130	AMIRKHANIAN	3.30	2.0	MW	1255P-0220P
6147	L/L	TH130	MELLO S	3.30	2.0	M	0630P-0940P

**MUS 5C Advanced Piano**

Advisory: Music 5B  
Transferable: CSU; UC; GAV-GE: C1

Development of advanced keyboard skills through means of scales, chords and technical studies. Continuation of music fundamentals and keyboard harmony; introduction of moderately difficult classical and standard piano literature.

4692	L/L	TH130	AMIRKHANIAN	3.30	2.0	MW	1255P-0220P
6148	L/L	TH130	MELLO S	3.30	2.0	M	0630P-0940P

**MUS 5D Advanced Piano**

Advisory: Music 5C  
Transferable: CSU; UC; GAV-GE: C1

Development of advanced keyboard skills through means of scales, chords and technical studies. Continuation of music fundamentals and keyboard harmony; introduction of moderately difficult classical and standard piano literature.

4693	L/L	TH130	AMIRKHANIAN	3.30	2.0	MW	1255P-0220P
6149	L/L	TH130	MELLO S	3.30	2.0	M	0630P-0940P

**MUS 8A Beginning Voice**

Advisory: Continues in sequence or by demonstrated proficiency.  
Transferable: CSU; UC; GAV-GE: C1

Development of techniques in the art of singing and interpreting serious music in various styles. Study of the basic techniques of tone production, breathing and related skills. Basic repertoire development.

4694	L/L	TH130	PRUITT N	2.30	2.0	TuTh	1120A-1245P
------	-----	-------	----------	------	-----	------	-------------

Sect. Type Room Instructor Hrs. Units Days Begin-End Footnotes

**MUS 8B Beginning Voice**

Advisory: Music 8A or demonstrated proficiency.  
Transferable: CSU; UC; GAV-GE: C1

Development of techniques in the art of singing and interpreting serious music in various styles. Study of the basic techniques of tone production, breathing and related skills. Basic repertoire development.

4695	L/L	TH130	PRUITT N	2.30	2.0	TuTh	1120A-1245P
------	-----	-------	----------	------	-----	------	-------------

**MUS 8C Intermediate Voice**

Advisory: Music 8B or demonstrated proficiency.  
Transferable: CSU; UC; GAV-GE: C1

Development of techniques in the art of singing and interpreting serious music in various styles. Study of the basic techniques of tone production, breathing and related skills. Basic repertoire development.

4696	L/L	TH130	PRUITT N	2.30	2.0	TuTh	1120A-1245P
------	-----	-------	----------	------	-----	------	-------------

**MUS 8D Intermediate Voice**

Advisory: Music 8C or demonstrated proficiency.  
Transferable: CSU; UC; GAV-GE: C1

Development of techniques in the art of singing and interpreting serious music in various styles. Study of the basic techniques of tone production, breathing and related skills. Basic repertoire development.

4697	L/L	TH130	PRUITT N	2.30	2.0	TuTh	1120A-1245P
------	-----	-------	----------	------	-----	------	-------------

**MUS 9A Guitar**

Advisory: Students must provide their own guitars.  
Transferable: CSU; UC; GAV-GE: C1

An introduction to playing the guitar. Basic staff notation, correct fingering and chord arpeggios are covered. Emphasis is also placed on developing musical listening skills. Students must provide their own guitars. May be repeated once for credit.

4698	LAB	HOL2	MONTOYA T	3.30	1.0	M	0100P-0405P
Above class meets at the Hollister Briggs site							
6150	LAB	AL101	MONTOYA T	3.30	1.0	M	0530P-0840P

**MUS 9B Guitar**

Advisory: Music 9A; students must provide their own guitars.  
Transferable: CSU; UC; GAV-GE: C1

An introduction to playing the guitar. Basic staff notation, correct fingering and chord arpeggios are covered. Emphasis is also placed on developing musical listening skills. Students must provide their own guitars. May be repeated once for credit.

6151	LAB	AL101	MONTOYA T	3.30	1.0	M	0600P-0910P
------	-----	-------	-----------	------	-----	---	-------------

**MUS 12 Vocal Ensemble**

Transferable: CSU; UC; GAV-GE: C1

The day Vocal Ensemble will focus on individual and group performance of popular and alternative commercial music, and will rehearse and perform with a backup band. The evening Vocal Ensemble will study, rehearse and perform choral music in a broad spectrum of musical genre and styles. Included will be the study of vocal and rehearsal techniques as they relate to ensemble performance. Course may be repeated three times for credit.

4699	L/L	AL101	JUNCKER A	4.40	2.0	MW	1255P-0300P
6152	L/L	GHS	ROBB P	4.40	2.0	Tu	0630P-0940P 67
See Footnote: Above class meets at the Gilroy High School music room							

Sect. Type Room Instructor Hrs. Units Days Begin-End Footnotes

**MUS 13 Concert Choir**

**Advisory:** Previous choral experience is preferred but not required. The student should have the ability to match a given pitch.

**Transferable:** CSU; UC; GAV-GE: C1

The Concert Choir will study, rehearse and perform choral music from the 15th century to the present in a variety of musical styles with emphasis on the larger choral works and their preparation for public concert. Course may be repeated three times for credit.

6153	L/L	GHS	ROBB P	4.40	2.0	Tu&1	0630P-0940P	67
------	-----	-----	--------	------	-----	------	-------------	----

See Footnote: Above class meets at the Gilroy High School music room

**MUS 14A Instrumental Ensemble**

**Transferable:** CSU; GAV-GE: C1

Instruction for the experienced musician with emphasis on the study and performance of a wide variety of musical styles from Renaissance to 20th century music for traditional ensembles, and extensive consideration of contemporary commercial and alternative repertoire, and performance techniques for popular ensembles.

4700	L/L	AL101	MARQUES A	4.40	2.0	MW	1255P-0300P
6154	L/L	SOLB7	QUARTUCCIO A	4.40	2.0	W&1	0640P-0950P

**MUS 14B Instrumental Ensemble**

**Transferable:** CSU; GAV-GE: C1

Instruction for the experienced musician with emphasis on the study and performance of a wide variety of musical styles from Renaissance to 20th century music for traditional ensembles, and extensive consideration of contemporary commercial and alternative repertoire, and performance techniques for popular ensembles.

4701	L/L	AL101	MARQUES A	4.40	2.0	MW	1255P-0300P
6155	L/L	SOLB7	QUARTUCCIO A	4.40	2.0	W&1	0640P-0950P

**MUS 14C Instrumental Ensemble**

**Transferable:** CSU; GAV-GE: C1

Instruction for the experienced musician with emphasis on the study and performance of a wide variety of musical styles from Renaissance to 20th century music for traditional ensembles, and extensive consideration of contemporary commercial and alternative repertoire, and performance techniques for popular ensembles.

4702	L/L	AL101	MARQUES A	4.40	2.0	MW	1255P-0300P
6156	L/L	SOLB7	QUARTUCCIO A	4.40	2.0	W&1	0640P-0950P

**MUS 14D Instrumental Ensemble**

**Transferable:** CSU; GAV-GE: C1

Instruction for the experienced musician with emphasis on the study and performance of a wide variety of musical styles from Renaissance to 20th century music for traditional ensembles, and extensive consideration of contemporary commercial and alternative repertoire, and performance techniques for popular ensembles.

4703	L/L	AL101	MARQUES A	4.40	2.0	MW	1255P-0300P
6157	L/L	SOLB7	QUARTUCCIO A	4.40	2.0	W&1	0640P-0950P

**MUS 21 Electronic Music/Sound Design**

**Advisory:** Eligible for English 250, 260 and Mathematics 205.

**Transferable:** CSU; GAV-GE: C1

Fundamentals of electronic music synthesis using computers. Midi sequencing, digital sound processing, sampling, digital multi-track recording utilizing the college's state of the art midi studio. May be repeated three times for credit.

4704	L/L	LI128	JUNCKER A	3.40	3.0	TuTh&2.3	1120A-1245P
------	-----	-------	-----------	------	-----	----------	-------------



*The most fun you'll ever have in a class!*

**MUS 12  
Vocal Ensemble**

**MUS 14A  
Instrumental Ensemble**

- Play:
- Rock & Roll
  - Jazz
  - Blues
  - Top Hits
  - Classics
  - Your original songs!

Arrange a personal tour!

Call 408-846-4993.

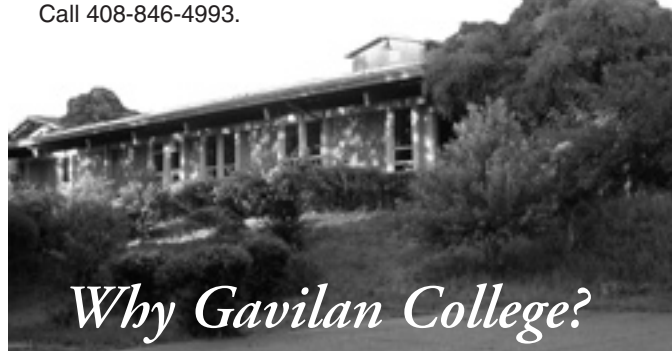

*Why Gavilan College?*

- Complete first two years of college coursework
- Easy transfer to UC, CSU and private universities
- Transfer agreements with UC, CSU and private universities
- Excellent faculty/helpful staff
- Small classes
- Beautiful campus
- No Silicon Valley commute
- Close to home
- Affordable

**Footnotes contain valuable information pertaining to your class selection. Footnotes follow class listings.**

Sect. Type Room Instructor Hrs. Units Days Begin-End Footnotes

**MUS 22 Field Work and Service**

**Required:** Learning contracts must be filled out and signed by the student and the supervising instructor.

**Transferable:** CSU

Supervised field work within the college and with local agencies. Students serve in useful group activities in leadership roles prescribed for them by faculty or community agencies. A maximum of six units may be completed. This is a credit/no credit course.

4705	FEX	GHS	ROBB P	3.40	1.0	DHR	0000-0000	21	67
See Footnote: Above class meets at the Gilroy High School music room.									
4706	FEX	AL101	QUARTUCCIO A	3.40	1.0	DHR	0000-0000	21	

**MUS 23 Independent Study**

**Required:** The study outline prepared by the student and the instructor must be filed with the department and the dean.

**Transferable:** CSU

Designed to afford selected students specialized opportunities for exploring areas at the independent study level. The courses may involve extensive library work, research in the community, or special projects. May be repeated until six units of credit are accrued. This course has the option of a letter grade or credit/no credit.

4707	IND	TH130	MELLO S	3.40	1.0	DHR	0000-0000	22	
4708	IND	GHS	ROBB P	3.40	1.0	DHR	0000-0000	22	67
See Footnote: Above class meets at the Gilroy High School music room.									
4709	IND	AL101	QUARTUCCIO A	3.40	1.0	DHR	0000-0000	22	
4710	IND	TH130	JUNCKER A	3.40	1.0	DHR	0000-0000	22	
4711	IND	AL102	JUNCKER A	6.80	2.0	DHR	0000-0000	22	
4712	IND	AL101	PRUITT N	3.40	1.0	DHR	0000-0000	22	
4713	IND	AL101	PRUITT N	6.80	2.0	DHR	0000-0000	22	
4714	IND	TH130	AMIRKHANIAN	3.40	1.0	DHR	0000-0000	22	
4715	IND	TH130	AMIRKHANIAN	6.80	2.0	DHR	0000-0000	22	
6158	IND	AL101	MONTOYA T	3.40	1.0	M&3.4	0600P-0850P	22	

**MUS 26 Symphony**

**Advisory:** Demonstrated proficiency on individual's instrument and ability to read music.

**Transferable:** CSU; UC; GAV-GE: C1

Study and performance of orchestral literature. Individual and sectional skills development. Perform in public concerts each semester. May be repeated until a maximum of 8 units are accrued.

6159	L/L	SOLB7	QUARTUCCIO A	4.40	2.0	W&1	0640P-0950P		
------	-----	-------	--------------	------	-----	-----	-------------	--	--

**MUS 98 Special Topics**

**Transferable:** CSU; GAV-GE: C1

Special topics courses examine current problems or issues of interest to students within a specific discipline area. For topical content information, consult with appropriate department chairperson. For transfer status, check with a counselor. This course may have the option of a letter grade or credit/no credit.

6160	LEC	GHS	ROBB P	1.00	1.0	Tu	0730P-0945P	67	
See Footnote: Above class meets at the Gilroy High School music room.									
6161	LEC	AL101	QUARTUCCIO A	1.00	1.0	W	0730P-0945P		

**Nursing: see Allied Health**

**Nutrition: see Biological Sciences**

**Performing Arts: see Theatre Arts (THEA)**

Sect. Type Room Instructor Hrs. Units Days Begin-End Footnotes

**PHILOSOPHY**

**PHIL 1 Introduction to Philosophy**

**Advisory:** Eligible for English 1A.

**Transferable:** CSU; UC; CSU-GE: C2; IGETC: 3B; GAV-GE: C2; CAN: PHIL 2

Philosophy 1 is intended as a survey of the major areas and traditions of philosophy. The course examines central and significant questions about the meaning of life, who determines what is morally right or wrong, the ideal society, the various notions social justice, what is reality, and many other ideas. In pursuing these questions, students will be asked to read texts from writers around the world, both contemporary and ancient, discuss current events, and apply 'theory' to movies such as "The Matrix" trilogy, novels, and any other relevant application of the student's own choice.

4776	LEC	CH102	HODGE E	3.40	3.0	TuTh	1255P-0220P		
------	-----	-------	---------	------	-----	------	-------------	--	--

**PHIL 2 Logic**

**Advisory:** Eligible for English 1A.

**Transferable:** CSU; UC; CSU-GE: A3; GAV-GE: C2; CAN: PHIL 6

Philosophy 2 is intended as a survey of the primary approaches to argumentation and what has been traditionally called 'correct' reasoning. Students will learn techniques of both deductive and inductive argumentation, basic symbolic logic, how to spot a fallacy, as well as how to apply these techniques to other aspects of their lives outside of the classroom. While logic is often quite formal, the goal is to see the practical application of this discipline. Students will become acquainted with the cultural variations to reasoning in addition to the standard Western focal approach.

4777	LEC	AR103	HODGE E	3.40	3.0	TuTh	0810A-0935A		
6168	LEC	HOL5	JOHNSTON M	3.40	3.0	W	0600P-0910P		
Above class meets at the Hollister Briggs site									

**PHIL 6A Comparative Religions**

**Advisory:** Eligible for English 1A.

**Transferable:** CSU; UC; CSU-GE: C2; IGETC: 3B; GAV-GE: C2, F

Religion is a topic that ignites controversy -- most societies engage in religious practices, believe strongly in that tradition, and find a sense of identity within it. The controversy arises when differences are misunderstood, misrepresented, or placed in a hierarchy of assumed supremacy of one religion as superior to others. In this class, students explore the underlying commonality of various religious traditions, explore the uniqueness of the religions with which they are unfamiliar, and learn to see that diversity among beliefs doesn't have to create hostility. Students will explore religions from Indigenous Peoples throughout the world, East Asia (e.g. India), China, the Middle East, as well as some more recent trends in religion.

4780	LEC	HU103	HODGE E	3.40	3.0	MW	1255P-0220P		
------	-----	-------	---------	------	-----	----	-------------	--	--

**PHIL 4 Critical Thinking and Writing**

**Prerequisite:** English 1A

**Transferable:** CSU; UC; CSU-GE: A3; IGETC: 1B; GAV-GE: C2

This course is designed to introduce the relationship between critical thinking and critical writing in a way that will be both enjoyable to the student and helpful in other aspects of life. The student will learn techniques of critical thinking, paying close attention to the current events, movies and popular media, music lyrics, as well as the textbook. Students will learn to identify deductive and inductive arguments and be able to evaluate their strength, create a strong argument of their own on a given topic, as well become experts in the area of critical analysis. The goal is to enable students to become strong, well informed, articulate members of the community as well as individuals with an empowered sense of self as an agent of change.

4778	LEC	SS111	HODGE E	3.40	3.0	MW	0945A-1110A		
4779	LEC	AR103	HODGE E	3.40	3.0	TuTh	0945A-1110A		

Sect. Type Room Instructor Hrs. Units Days Begin-End Footnotes

**PHIL 6A Comparative Religions**

**Advisory:** Eligible for English 1A.

**Transferable:** CSU; UC; CSU-GE: C2; IGETC: 3B; GAV-GE: C2, F

Religion is a topic that ignites controversy -- most societies engage in religious practices, believe strongly in that tradition, and find a sense of identity within it. The controversy arises when differences are misunderstood, misrepresented, or placed in a hierarchy of assumed supremacy of one religion as superior to others. In this class, students explore the underlying commonality of various religious traditions, explore the uniqueness of the religions with which they are unfamiliar, and learn to see that diversity among beliefs doesn't have to create hostility. Students will explore religions from Indigenous Peoples throughout the world, East Asia (e.g. India), China, the Middle East, as well as some more recent trends in religion.

4780 LEC HU103 HODGE E 3.40 3.0 MW 1255P-0220P

**PHIL 23 Independent Study**

**Required:** The study outline prepared by the student and the instructor must be filed with the department and the dean.

**Transferable:** CSU

Designed to afford selected students specialized opportunities for exploring areas at the independent study level. The courses may involve extensive library work, research in the community, or special projects. May be repeated until six units of credit are accrued. This course has the option of a letter grade or credit/no credit.

4781 IND SS106 HODGE E 3.40 1.0 DHR 0000-0000

**Photography: see Art, CSIS or Digital Media**

**PHYSICAL EDUCATION: ACADEMIC**

**PE 6 Games and Rhythms for Children**

**Advisory:** Eligible for English 250 and English 260.

**Transferable:** CSU; GAV-GE: E1

Nature, function and organization of physical activities for the pre-school and elementary school age child. Emphasis is given to the understanding of psychomotor development and spatial awareness. Designed for those planning to work with children. Also listed as Child Development 6. This course has the option of a letter grade or credit/no credit.

4716 LEC APE120 DODD S 3.40 3.0 TuTh 0810A-0935A 25

**PHYSICAL EDUCATION: ACTIVITIES**

**PE 16 Swimming**

**Transferable:** CSU; UC; CSU-GE: E1; GAV-GE: E1

Coeducational activity designed for all skill levels. The course teaches the techniques of a variety of strokes and includes conditioning activities. Instruction is tailored to meet individual and group needs. May be repeated three times for credit. This course has the option of a letter grade or credit/no credit.

4717 LAB GY100P DODD S 3.40 1.0 MW 1255P-0220P

4718 LAB GY100P DODD S 3.40 .5 MW 1255P-0220P 11  
03/26/07 - 05/23/07

**PE 17 Golf**

**Transferable:** CSU; UC; CSU-GE: E1; GAV-GE: E1

Coeducational activity designed for all skill levels; fundamentals, techniques, rules and etiquette of golf. May be repeated three times for credit. This course has the option of a letter grade or credit/no credit.

4719 LAB GY200C ANDRADE N 3.40 1.0 MW 1120A-1245P 49

4720 LAB GY200C ANDRADE N 3.40 .5 MW 1120A-1245P 11 49  
03/26/07 - 05/23/07

6162 LAB GY200C KRAUSE S 3.40 .5 S 0900A-1200P 11 43 49  
03/31/07 - 05/19/07

**PE 19**

**BADMINTON is back!**

**PE 73**

**FITNESS THROUGH DANCE**



**PE 24 Individualized Weight Training**  
**PE 64 Cardiovascular Fitness**

**Spring Semester Fitness Center Lab Hours**

Day	MWF	7:00 am - 2:00 pm
	TuTh	9:30 am - 1:30 pm
Eve.	MTuWTh	4:30 pm - 6:30 pm

- Section hours by arrangement
- ✦ 1.7 to 3.4 weekly hours
  - ✦ .5 or 1.0 unit
  - ✦ Fitness Center (GYM 123)



**Open Lab Class Format**  
Designed for individualized strength or cardiovascular fitnee programs in an open lab setting using a variety of exercise equipment.

**Students should check in the first week of the semester during lab hours.**

Students should be aware that there are inherent risks involved in any physical exercise. Students are strongly advised to consult a physician prior to participating in any physical education activity.

**PE Activities** Classes can be taken for letter grade or CR/NC.

Sect. Type Room Instructor Hrs. Units Days Begin-End Footnotes

## PE 19 Badminton

Transferable: CSU; UC; CSU-GE: E1; GAV-GE: E1

Coeducational activity designed for beginning and intermediate badminton students; rules, etiquette and fundamentals of badminton. May be repeated three times for credit. This course has the option of a letter grade or credit/no credit.

4721 LAB GY131G LANGOJ 3.40 1.0 F 1040A-0140P

## PE 20 Bowling

Transferable: CSU; UC; CSU-GE: E1; GAV-GE: E1

Coeducational activity designed for beginning and intermediate bowlers; fundamentals and techniques of bowling. Scoring, bowling etiquette, terminology and team bowling are included. May be repeated three times for credit. This course has the option of a letter grade or credit/no credit.

4722 LAB GIBOWL LANGOJ 3.40 1.0 TuTh 0810A-0935A 62  
See Footnote: Above class meets Off Campus

## PE 21 Volleyball

Transferable: CSU; UC; CSU-GE: E1; GAV-GE: E1

Coeducational activity designed for beginning and intermediate volleyball students; rules, strategy and fundamentals of volleyball. May be repeated three times for credit. This course has the option of a letter grade or credit/no credit.

4723 LAB GY131G STAFF 3.40 1.0 MW 1255P-0220P

## PE 23 Independent Study

Required: The study outline prepared by the student and the instructor must be filed with the department and the dean.

Transferable: CSU

Designed to afford selected students specialized opportunities for exploring areas at the independent study level. The courses may involve extensive library work, research in the community, or special projects. May be repeated until six units of credit are accrued. This course has the option of a letter grade or credit/no credit.

4724 IND GY116 DODD S 6.40 2.0 DHR 0000-0000 22

## PE 24 Individualized Weight Training

Transferable: CSU; UC; CSU-GE: E1; GAV-GE: E1

An open laboratory for those who desire an individualized strength program using exercise machines and free weights. May be repeated three times for credit. This course has the option of a letter grade or credit/no credit.

4725 LAB GY123 DODD S 3.40 1.0 day-time see ad 87

4726 LAB GY123 DODD S 1.70 .5 day-time see ad 87

## PE 25 Soccer

Transferable: CSU; UC; CSU-GE: E1; GAV-GE: E1

Co-educational activity designed for all skill levels. Fundamentals, strategy and rules of the game are included. May be repeated three times for credit. This course has the option of a letter grade or credit/no credit.

4727 LAB GY131G ESPINOZA J 3.40 1.0 MW 0810A-0935A

## PE 27 Basketball

Transferable: CSU; UC; CSU-GE: E1; GAV-GE: E1

Co-educational activity designed for all skill levels. Fundamentals, strategy and rules of the game are included. May be repeated three times for credit. This course has the option of a letter grade or credit/no credit.

4728 LAB GY131G ADDISON T 3.40 .5 TuTh 0230P-0430P 11  
03/27/07 - 05/24/07

Sect. Type Room Instructor Hrs. Units Days Begin-End Footnotes

## PE 39 Fencing

Transferable: CSU; UC; CSU-GE: E1; GAV-GE: E1

This course will explore the offensive and defensive fencing skills with a foil. May be repeated three times credit. This course has the option of a letter grade or credit/no credit.

6163 LAB GY131G DECESARE J 3.40 1.0 M 0630P-0940P 44

## PE 44 Aerobics

Transferable: CSU; UC; CSU-GE: E1; GAV-GE: E1

A program of aerobic fitness. Includes various forms of exercise to improve health, heart, and body composition. May be repeated three times for credit. This course has the option of a letter grade or credit/no credit.

4744 LAB GY131G THOMPSON N 3.40 1.0 MW 1120A-1245P

## PE 46 Agility and Motor Development

Transferable: CSU; UC; CSU-GE: E1; GAV-GE: E1

An activity class designed to improve and increase agility and motor development through various exercise and exercise programs. May be repeated three times for credit. This course has the option of a letter grade or credit/no credit.

4745 LAB GY131G LANGOJ 3.40 1.0 MTuWTh 0310P-0400P

4746 LAB GY131G LANGOJ 3.40 .5 MTuWTh 0310P-0400P 11  
03/19/07 - 05/24/07

## PE 61 Swim for Fitness

Transferable: CSU; UC; CSU-GE: E1; GAV-GE: E1

Designed to develop endurance and swimming skills in order to maintain good cardiovascular/physical fitness. Intermediate swimming ability recommended. May be repeated three times for credit. This course has the option of a letter grade or credit/no credit.

6164 LAB GY100P DODD S 3.40 .5 TuTh 0515P-0640P 11  
03/20/07 - 05/24/07

## PE 62 Yoga

Transferable: CSU; UC; CSU-GE: E1; GAV-GE: E1

Co-educational activity designed for beginning yoga students. A program designed to improve flexibility and reduce stress, by learning a series of postures and focusing on proper breathing techniques. May be repeated three times for credit. This course has the option of a letter grade or credit/no credit.

4747 LAB APE101 MUSCARI D 3.40 1.0 TuTh 1255P-0220P

6165 LAB MHG10 WATSON M 3.40 1.0 M W 0500P-0625P  
Above class meets at Morgan Hill Community site

6167 LAB VET218 MUSCARI D 3.40 1.0 TuTh 0500P-0625P 41  
See Footnote: Above class meets at the Veteran's Memorial Bldg., Hollister

## PE 64 Individualized Cardiovascular Fitness

Transferable: CSU; UC; CSU-GE: E1; GAV-GE: E1

A fitness program which develops cardiovascular endurance through an individualized open lab format. May be repeated three times for credit. This course has the option of a letter grade or credit/no credit.

4748 LAB GY123 DODD S 3.40 1.0 day-time see ad 87

4749 LAB GY123 DODD S 1.70 .5 day-time see ad 87

## PE 70 Pilates

Transferable: CSU; UC; CSU-GE: E1; GAV-GE: E1

This class utilizes the Pilates exercise system focused on improving flexibility and strength for the total body through a series of controlled movements. May be repeated three times for credit. This course has the option of a letter grade or credit/no credit.

4751 LAB APE101 MUSCARI D 3.40 1.0 MW 1255P-0220P

Sect. Type Room Instructor Hrs. Units Days Begin-End Footnotes



**PE 73 Fitness Through Dance**

Transferable: CSU; UC; CSU-GE: E1; GAV-GE: E1

Conditioning the body through the use of various dances and/or dance steps. This course is designed to strengthen and tone the body, assist in weight loss, and increase endurance. May be repeated three times for credit. This course has the option of a letter grade or credit/no credit.

4752 LAB APE101 WAGGONER K 3.40 1.0 TuTh 1120A-1245P



**ALUMNI** *Profile*

**Sabrina Murphy:**

My freshmen year of college I attended a private 4- year school. The college was not worth a \$30,000 tuition. I wasn't crazy about my decision to go to Gavilan College because I didn't think it would be possible for me to get picked up by a Division I school for basketball. Once I started going to Gavilan college I realized how great it was. It was so close to home and inexpensive. I was receiving better education at Gavilan College than I had at the 4-year school.

I was a member of the women's basketball team at Gavilan College and played well enough to receive an honorable mention from the league. I averaged 13 points per game and was invited to attend the Sophomore Showcase in San Diego. This event has the best players in California and they play against each other on teams in front of scouts from different universities across the U.S.

I graduated Gavilan College with my AA in Liberal Studies and was able to continue my education at San Jose State where I was able to also be a member of the women's basketball team. My junior year at state I walked on to the team and commuted back and forth from my home in Hollister. My senior year I received a full scholarship for basketball and I graduated in May with a BA in Psychology and a minor in Sociology.

Gavilan College helped me save money and gave me the same (if not better) education than a private institution. If I had to redo my education, I would have attended Gavilan College for two years instead of one. My advice to students now (since I occasionally substitute teach and coach the girls team at Anchor Point Christian School in Gilroy) is to go to a junior college like Gavilan College first to save money. There is no point in paying astronomical amounts of money for the first two years of college.

**PHYSICAL EDUCATION: ADAPTED**

**PE 34 Adapted Aquatic Exercise**

Transferable: CSU; UC; CSU-GE: E1; GAV-GE: E1

Designed to help individuals who by the nature of their disability such as wheelchair use, back injury, cardiovascular impairment, multiple sclerosis or other disabling condition require a specific aquatic exercise program that will contribute to their physical well-being. May be repeated as necessary based on measurable progress as documented in the student's educational contract. This course has the option of a letter grade or credit/no credit.

4729 LAB GY100P ELLIS D 3.40 1.0 MW 0810A-0935A 90 75

4730 LAB GY100P ELLIS D 3.40 1.0 MW 1120A-1245P 90 75  
CRETIN A

4731 LAB GY100P ELLIS D 3.40 1.0 TuTh 1120A-1245P 90 75  
CRETIN A

**PE 35 Adapted Swimming for Total Fitness**

Transferable: CSU; UC; CSU-GE: E1; GAV-GE: E1

An individualized program of activities designed for students with physical disabilities to improve flexibility and range-of-motion, increase joint movement, improve circulation, and improve control of body movement through water adjustment and activities. Develops an appreciation of physical activity as a regular planned contribution to one's overall well-being. May be repeated as necessary based on measurable progress as documented in the student's educational contract. This course has the option of a letter grade or credit/no credit.

4732 LAB GY100P ELLIS D 3.40 1.0 MW 0810A-0935A 90 75

4733 LAB GY100P ELLIS D 3.40 1.0 TuTh 1120A-1245P 90 75  
CRETIN A

4734 LAB GY100P ELLIS D 3.40 1.0 MW 1255P-0220P 90 75

**PE 36 Adapted Physical Education**

Transferable: CSU; UC; CSU-GE: E1; GAV-GE: E1

An individualized program of adaptive physical education activities designed to meet the needs of students with physical disabilities. Develops an appreciation of physical activity as a regular planned contribution to one's overall well-being. May be repeated as necessary based on measurable progress as documented in the student's educational contract. This course has the option of a letter grade or credit/no credit.

4735 LAB APE108 ELLIS D 3.40 1.0 TuTh 0945A-1110A 90 75  
APE120 ELLIS D  
APE121 ELLIS D

4736 LAB APE108 ELLIS D 3.40 1.0 MW 0945A-1120A 90 75  
APE120 ELLIS D  
APE121 ELLIS D

4737 LAB APE108 ELLIS D 3.40 1.0 MW 1120A-1245P 90 75

4738 LAB APE108 ELLIS D 3.40 1.0 TuTh 1255P-0220P 90 75  
APE120 ELLIS D  
APE121 ELLIS D

**BACH TO BLUES**  
**March 9, 2007**  
 7 pm in the Gavilan College Theater



Performers include:  
 Nate Pruitt  
 John Garcia  
 Maria Amirkhanian  
 Albert Marques  
 Art Juncker with the Gavilan Ensemble  
 Candace Fazio  
 The Marian Filice Piano Competition winner

Theatre Arts Box Office: 408-846-4973

Presented by Gavilan College in association with  
 South Valley Symphony

Footnotes contain valuable information pertaining to your class selection. Footnotes follow class listings.

Sect. Type Room Instructor Hrs. Units Days Begin-End Footnotes

**PE 38 Adapted Cardiovascular Conditioning & Training**

Transferable: CSU; UC; CSU-GE: E1; GAV-GE: E1

Prescribed exercises in weight training, stretching and cardiovascular conditioning for those individuals that have been disabled through stroke, cardiovascular accident, arthritis, multiple sclerosis, or other condition. May be repeated as necessary based on measurable progress as documented in the student's educational contract. This course has the option of a letter grade or credit/no credit.

4740	LAB	APE108 APE120 APE121	ELLIS D ELLIS D ELLIS D	3.40	1.0	MW	0945A-1110A	90 75
4741	LAB	APE108 APE120 APE121	ELLIS D ELLIS D ELLIS D	3.40	1.0	TuTh	0945A-1110A	90 75
4742	LAB	APE108 APE120 APE121	ELLIS D ELLIS D ELLIS D	3.40	1.0	MW	1120A-1245P	90 75
4743	LAB	APE108 APE120 APE121	ELLIS D ELLIS D ELLIS D	3.40	1.0	TuTh	1255P-0220P	90 75

**PE 534 Adapted Aquatic Exercise**

Transferable: No

Designed to help individuals who by the nature of their disability such as wheelchair use, back injury, cardiovascular impairment, multiple sclerosis or other disabling condition require a specific aquatic exercise program that will contribute to their physical well being. May be repeated as necessary based on measurable progress as documented in the student's educational contract. This is a credit/no credit course.

4753	LAB	GY100P	ELLIS D	3.40	1.0	MW	0810A-0935A	90 75
4755	LAB	GY100P	ELLIS D	3.40	1.0	MW	1120A-1245P	90 75
4756	LAB	GY100P	ELLIS D CRETIN A	3.40	1.0	TuTh	1120A-1245P	90 75

**PE 535 Adapted Swimming for Total Fitness**

Transferable: No

An individualized program of activities designed for students with physical disabilities to improve flexibility and range-of-motion, increase joint movement, improve circulation, and improve control of body movement through water adjustment and activities. Develops an appreciation of physical activity as a regular planned contribution to one's overall well-being. May be repeated as necessary based on measurable progress as documented in the student's educational contract. This course is credit/no credit.

4757	LAB	GY100P	ELLIS D	3.40	1.0	MW	0810A-0935A	90 75
4758	LAB	GY100P	ELLIS D CRETIN A	3.40	1.0	TuTh	1120A-1245P	90 75
4759	LAB	GY100P	ELLIS D	3.40	1.0	MW	1255P-0220P	90 75

**Your educational plan:**

You are expected to take the responsibility for scheduling an appointment with a counselor, preferably at least once a semester. The purpose of this appointment is to develop, review and update your educational plan to ensure that you are taking the appropriate courses to meet your educational goal.

Sect. Type Room Instructor Hrs. Units Days Begin-End Footnotes

**PE 536 Adapted Physical Education**

Transferable: No

An individualized program of adaptive physical education activities designed to meet the needs of students with physical disabilities. Develops an appreciation of physical activity as a regular planned contribution to one's overall well-being. May be repeated as necessary based on measurable progress as documented in the student's educational contract. This is a credit/no credit course.

4761	LAB	LOADCS	CRETIN A	3.40	1.0	MW	0930A-1055A	70 90 75
See Footnote: Above class meets Off Campus								
4762	LAB	APE108 APE120 APE121	ELLIS D ELLIS D ELLIS D	3.40	1.0	MW	0945A-1110A	90 75
4763	LAB	APE108 APE120 APE121	ELLIS D ELLIS D ELLIS D	3.40	1.0	TuTh	0945A-1110A	90 75
4764	LAB	HOLLCC	CRETIN A	3.40	1.0	MW	1120A-1245P	68 90 75
See Footnote: Above class meets Off Campus								
4765	LAB	APE108	ELLIS D	3.40	1.0	MW	1120A-1245P	90 75
4766	LAB	APE108 APE120 APE121	ELLIS D ELLIS D ELLIS D	3.40	1.0	TuTh	1255P-0220P	90 75

**PE 538 Adapted Cardiovascular Conditioning & Training**

Transferable: No

Prescribed exercises in weight training, stretching and cardiovascular conditioning for those individuals that have been disabled through stroke, cardiovascular accident, arthritis, multiple sclerosis, or other condition. May be repeated as necessary based on measurable progress as documented in the student's educational contract. This is a credit/no credit course.

4767	LAB	APE108 APE120 APE121	ELLIS D ELLIS D ELLIS D	3.40	1.0	MW	0945A-1110A	90 75
4768	LAB	APE108 APE120 APE121	ELLIS D ELLIS D ELLIS D	3.40	1.0	TuTh	0945A-1110A	90 75
4769	LAB	LOADCS	CRETIN A	3.40	1.0	TuTh	0945A-1110A	70 75
See Footnote: Above class meets Off Campus								
4770	LAB	APE108 APE120 APE121	ELLIS D ELLIS D ELLIS D	3.40	1.0	MW	1120A-1245P	90 75
4771	LAB	APE108 APE120 APE121	ELLIS D ELLIS D ELLIS D	3.40	1.0	TuTh	1255P-0220P	90 75

**PE 547 Back Rehabilitation**

Advisory: Doctor, physical therapist, and/or chiropractor referral required for entrance into class.

Transferable: No

A course designed for the individuals with back injuries which last several months or longer. The course is geared toward education, motivation, and a supervised program geared toward self-improvement and prevention for the back's well-being. The class will emphasize a wide variety of stretching and relaxation techniques as well as breathing exercises and nutritional practices for stress reduction and its relationship to one's back health as well as total wellness. This class is not designed to replace physical therapy, but to complement it and to continue once physical therapy has been terminated. This class is offered on an open/entry open/exit basis.

4772	LAB	LOADCS	MARINGER J	1.00	1.0	F	1000A-1100A	70 31 75
------	-----	--------	------------	------	-----	---	-------------	----------

Sect. Type Room Instructor Hrs. Units Days Begin-End Footnotes

## INTERCOLLEGIATE ATHLETICS

**ATH 35 Basketball**

Transferable: CSU; UC; CSU-GE: E1; GAV-GE: E1

This course provides practice and competition in intercollegiate basketball. May be repeated three times for credit. This course has the option of a letter grade or credit/no credit.

4130 LAB GY131G ADDISON T 10.00 1.0 DAILY 0230P-0430P 11  
01/31/07 - 03/09/07**ATH 36 Golf**

Transferable: CSU; UC; CSU-GE: E1; GAV-GE: E1

This course provides practice and competition in intercollegiate golf. May be repeated three times for credit. This course has the option of a letter grade or credit/no credit.

4131 LAB GY200C KRAUSE S 10.00 2.0 DAILY 0230P-0430P

**ATH 38 Baseball**

Transferable: CSU; UC; CSU-GE: E1; GAV-GE: E1

This course provides practice and competition in intercollegiate baseball for men. May be repeated three times for credit. This course has the option of a letter grade or credit/no credit.

4132 LAB GY131G ANDRADE N 10.00 2.0 DAILY 0230P-0430P

**ATH 45 Softball**

Transferable: CSU; UC; CSU-GE: E1; GAV-GE: E1

This course provides practice and competition in intercollegiate softball for women. May be repeated three times for credit. This course has the option of a letter grade or credit/no credit.

4133 LAB GY131G THOMPSON N 10.00 2.0 DAILY 0230P-0430P

## PHYSICAL SCIENCE

**PSCI 1 Principles of Physical Science**

Advisory: Mathematics 205 and eligible for English 250 and 260.

Transferable: CSU; UC; CSU-GE: B1; IGETC: 5A; GAV-GE: B1

An introduction to the physical sciences for the non-science major. Attention is focused on fundamental laws of nature, their development and relation to the physical world.

6170 LEC HOL1 SNYDER J 3.40 3.0 Tu 0630P-0940P  
Above class meets at the Hollister Briggs site**PSCI 2 Introduction to Meteorology**

Advisory: MATH 205.

Transferable: CSU; UC; CSU-GE: B1; IGETC: 5A; GAV-GE: B1

An introductory course in Meteorology that is both descriptive and analytical on the physical principles affecting the earth's weather. Topics covered include the nature of the atmosphere, solar energy, heat, temperature, pressure, stability, moisture, wind, storms, severe weather and forecasting. The course introduces climatology as a scientific study and will look at the earth's climatic history, current research in climate modeling and the possibility of global climate change.

4796 ONLINE VANTUYLA 3.40 3.0 DHR 0000-0000

This online class will be delivered entirely over the internet. After enrolling, start the class by going to <http://www.gavilan.edu/disted/>, click on your class link, and email the instructor at [avantuyla@gavilan.edu](mailto:avantuyla@gavilan.edu). Students who have not begun the class or contacted the instructor by 5 pm on Monday, February 5 will be dropped from the class.

## CSIS 61

## Geographic Information Systems

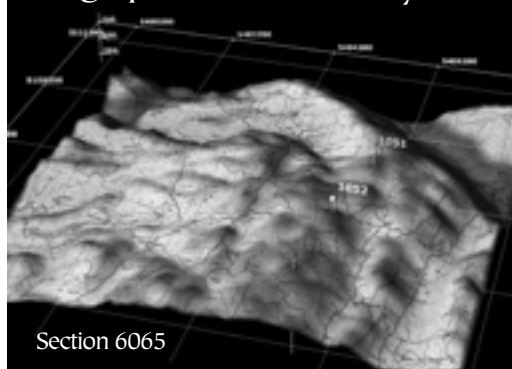

What do Administration of Justice, Biology, Business, Ecology, Economics, Geography, Geology, History, Landscaping, Public Health, Urban Planning, and Zoology have in common? **GIS!**

Offered Thursday evenings, 6-9:50 pm  
in BU III (on the Gilroy main campus)



MESA

MATHEMATICS • ENGINEERING • SCIENCE ACHIEVEMENT

- ◆ Are you a math based major? (BIO, CSIS, Architecture, etc.)
- ◆ Do you want to transfer to a 4-year university?
- ◆ Do you have financial need? You may be eligible!

Gavilan's MESA Program is now accepting applications. MESA students are entitled to workshops, academic advising, field trips, tutoring and more!

For more information call 408-848-4887 or visit the MESA Study Center in PH 105.

◆ [www.gavilan.edu/MESA](http://www.gavilan.edu/MESA) ◆

## MATH ♦ ENGINEERING ♦ SCIENCE MAJORS

**PLANNING TO TRANSFER?**

Admission for these majors is very competitive

4-year universities stress preparation for the major over completion of general education major.

High-unit majors do not need to fulfill all general education requirements

You do not need to get an AA or AS degree to transfer

You should plan your sequential courses early.

can help you plan your courses to complete major preparation prior to transfer. Go to [www.assist.org](http://www.assist.org) and see a counselor to develop an educational plan.



Sect. Type Room Instructor Hrs. Units Days Begin-End Footnotes

**PHYSICS**

**PHYS 1 Introduction to Physics**

**Advisory:** Mathematics 205.

**Transferable:** CSU; UC; CSU-GE: B1, B3; IGETC: 5A; GAV-GE: B1, B3

This course is an introduction to the fundamental physical principles that control the world around us. Students will explore the fundamental principles of physics, their historical development, their application to everyday phenomena, and their impact upon political, social, and environmental issues. Laboratory exercises will explore the everyday world.

4782 L/L PH102 LEE R 6.80 4.0 TuTh 0945A-1250P 1

**PHYS 2B General Physics**

**Prerequisite:** Physics 2A

**Advisory:** Eligible for English 250 and English 260

**Transferable:** CSU; UC; CSU-GE: B1, B3; IGETC: 5A; GAV-GE: B1, B3; CAN: PHYS 4, PHYS SEQ. A

An introduction to the principles of physics using algebra and trigonometry. Topics include electricity and magnetism, light and optics, modern physics, and an introduction to relativity.

4783 L/L PH102 LEE R 6.80 4.0 MW 1120A-1245P 1  
 LEE R F 1140A-1240P  
 LEE R W 0230P-0435P

**Physiology: see Biological Sciences**

**POLITICAL SCIENCE**

**POLS 1 Introduction to American Government**

**Advisory:** Eligible for English 250 and English 260.

**Transferable:** CSU; UC; CSU-GE: D8; IGETC: 4H, 7A; GAV-GE: D1, D2; CAN: GOVT 2

Explores the development of American political institutions and their utilization in dealing with issues arising at the international, national and state levels. Emphasis is placed on those problems which have defined our federal system of government. California government and appropriate state institutions will be included as a vital part of our federal system of government.

4784 LEC SS210 TURETZKY M 3.40 3.0 MW 0810A-0935A

4785 LEC SS210 TURETZKY M 3.40 3.0 TuTh 0810A-0935A

4786 LEC HOL1 KIERD 3.40 3.0 TuTh 0945A-1110A  
 Above class meets at the Hollister Briggs site

4787 LEC GHS STAFF 3.40 3.0 Tu 0310P-0620P 86

This class is part of the High Step program. It will be offered at Gilroy High School, room BE. This class is open to all students. For more information, see a Gavilan counselor.

4788 ONLINE TURETZKY M 3.40 3.0 DHR 0000-0000 38

 This online class will be delivered entirely over the internet. After enrolling, start the class by going to <http://www.gavilan.edu/disted/>, click on your class link, and email the instructor at [mturetzky@gavilan.edu](mailto:mturetzky@gavilan.edu). Students who have not begun the class or contacted the instructor by 5 pm on Monday, February 5 will be dropped from the class.

6169 LEC SS210 TURETZKY M 3.40 3.0 M 0630P-0940P

**POLS 3 Introduction to Comparative Politics**

**Advisory:** Eligible for English 250 and English 260.

**Transferable:** CSU; UC; CSU-GE: D8; IGETC: 4H; GAV-GE: D2, F

Comparative survey of political institutions and processes around the globe. Selected nations may include, but are not restricted to: the United Kingdom, France, Germany, Japan, Russia, India, Nigeria, and Mexico.

4789 LEC LI171 TURETZKY M 3.40 3.0 MW 0945A-1110A

Sect. Type Room Instructor Hrs. Units Days Begin-End Footnotes

**POLS 4 Introduction to International Relations**

**Transferable:** CSU; UC; CSU-GE: D8; IGETC: 4H; GAV-GE: D2, F

This course provides an introduction to key contemporary international problems and the means to analyze them. Major parts of the course cover such topics as war and peace, foreign policymaking, the international economy, and future trends in world politics.

4790 ONLINE TURETZKY M 3.0 DHR 0000-0000 13

 This hybrid lecture/online class will be delivered partially over the internet. See the online syllabus for details. <http://www.gavilan.edu/disted/>.

**POLS 6 Introduction to Conflict Resolution**

**Advisory:** English 250 and English 260.

**Transferable:** CSU; CSU-GE: D7; GAV-GE: D2

Introduction to Conflict Resolution introduces students to conflict resolution and mediation. Integrating theory and practice, students will assess core concepts about the causes and resolution of conflict, and will practice communication skills for conflict resolution. Students will examine how ethnicity, gender, and class affect power in conflict situations. They will be able to formulate appropriate conflict resolution strategies, and will develop and practice various basic co-mediation skills. This course has the option of a letter grade or credit/no credit. This course is also listed as AJ 6 and PSYC 6 and CMUN 6.

4791 LEC SS205 HALPER L 3.40 3.0 MW 0945A-1110A 25

**POLS 22 Field Work and Service**

**Required:** Learning contracts must be filled out and signed by the student and the supervising instructor.

**Transferable:** CSU

Supervised field work within the college and with local agencies. Students serve in useful group activities in leadership roles prescribed for them by faculty or community agencies. A maximum of six units may be completed. This is a credit/no credit course.

4792 FEX SS107 TURETZKY M 3.40 1.0 DHR 0000-0000 21

**POLS 23 Independent Study**

**Required:** The study outline prepared by the student and the instructor must be filed with the department and the dean.

**Transferable:** CSU

Designed to afford selected students specialized opportunities for exploring areas at the independent study level. The courses may involve extensive library work, research in the community, or special projects. May be repeated until six units of credit are accrued. This course has the option of a letter grade or credit/no credit.

4793 IND SS107 TURETZKY M 3.40 1.0 DHR 0000-0000 22

4794 IND SS107 TURETZKY M 6.40 2.0 DHR 0000-0000 22

**POLS 27 Contemporary Leadership**

**Advisory:** Eligible for English 250 and English 260.

**Transferable:** CSU; GAV-GE: E2

A cross-disciplinary approach to the theory and practice of leadership. Includes effective communication styles including issues related to gender and culture. Class includes topics on ethics, power, and how to run effective meetings including the use of parliamentary procedure. Skills directly applicable to work, personal and college environments. May be repeated for a maximum of 10 units. Also listed as PSYC 27.

4795 L/L LS101 STEWART J 4.60 3.0 TuTh&2 0810A-0930A 25

Sect. Type Room Instructor Hrs. Units Days Begin-End Footnotes

## PSYCHOLOGY

**PSYC 1A Introduction to Psychology****Advisory:** Eligible for English 250 and English 260.**Transferable:** CSU; UC; CSU-GE: D9; IGETC: 4I; GAV-GE: D2; CAN: PSY 2

The nature, scope, methods, presuppositions, history, and fields of psychology together with the scientific study of factors influencing human behavior, human development, perception, learning, memory, emotion, personality, frustration, and psychotherapy.

4797 LEC SS214 OLERC 3.40 3.0 MW 0810A-0935A

4798 LEC SS214 HINNG 3.40 3.0 TuTh 0810A-0935A

4799 LEC HOL1 OLERC 3.40 3.0 TuTh 1120A-1245P

Above class meets at Hollister Briggs site

4800 LEC MHG3 LEACH K 3.40 3.0 TuTh 1120A-1245P

Above class meets at Morgan Hill Community site

4801 LEC SS210 OLERC 3.40 3.0 MW 0230P-0405P

4802 LEC GHS LEACH K 3.40 3.0 M 0310P-0620P 84

This class is part of the High Step program. It will be offered at Gilroy High School, room B3. This class is open to all students. For more information, see a Gavilan counselor.

6171 LEC SS214 CAMPILLI J 3.40 3.0 M 0600P-0910P

6172 LEC MHG10 OLERC 3.40 3.0 Th 0600P-0910P

Class meets at the Morgan Hill Community site

**PSYC 1B Introduction to Psychology****Advisory:** Psychology 1A**Transferable:** CSU; UC; CSU-GE: D9; IGETC: 4I; GAV-GE: D2

Continuation of Psychology 1A. This course stresses the biological basis of behavior including: neuroanatomy, the senses, perception, learning, thinking, and psychological disorders.

4803 LEC SS214 OLERC 3.40 3.0 MW 0945A-1110A

**PSYC 2 Early Child Development****Advisory:** Eligible for English 250 and English 260.**Transferable:** CSU; UC; CSU-GE: D9, E ; IGETC: 4I; GAV-GE: D2

A systematic study of the child from prenatal life through the preschool years. The course integrates the basic concepts of physical, cognitive and psychosocial development at each major stage of life during this period. This course is also listed as CD 2. This course has the option of a letter grade or credit/no credit.

**LEARNING COMMUNITY SECTIONS:**

4899 LEC LS104 CLABAUGH D 3.40 3.0 TuTh 1120A-1245P 25 36

This class is part of a Learning Community. Students enrolled are encouraged to also take ENGL 250, section 4903. See ad on page 71.

4901 LEC LS104 CLABAUGH D 3.40 3.0 TuTh 1120A-1245P 25 36

This class is part of a Learning Community. Students enrolled are encouraged to also take ENGL 250, section 4904. See ad on page 71.

**OTHER SECTION:**

4804 LEC LS104 CLABAUGH D 3.40 3.0 TuTh 1120A-1245P 25

**PSYC 3 Child Growth and Development During the School Years****Advisory:** Eligible for English 250 and English 260; Psychology 2.**Transferable:** CSU; UC; CSU-GE: D9, E ; IGETC: 4I; GAV-GE: D2

Continuation of the study of child development with emphasis on children from six years of age through adolescence. Includes developmental theories and topics relevant to these ages. This course is also listed as CD 3. This course has the option of a letter grade or credit/no credit.

4805 LEC MHG4 SEGAL M 3.40 3.0 MW 1120A-1245P 25

Above class meets at Morgan Hill Community site

6173 LEC HOL2 BROWN R 3.40 3.0 M 0600P-0910P 25

Above class meets at the Hollister Briggs site

**Footnotes contain valuable information pertaining to your class selection. Footnotes follow class listings.**

**FACULTY Profile****Carlton Oler, PhD:**

Psychology Instructor (coler@gavilan.edu)

Since 2004, Dr. Oler has been Associate Professor of Psychology & Counseling at Alabama A&M University, teaching at both the undergraduate and graduate levels, and at Oakwood College in Huntsville, Alabama (where he had earlier taught from 1994-2000.) Prior to that he worked as a Clinical Psychologist at the Weems Community Mental Health Center, Meridian, MS, as a Postdoctoral Clinical Psychology Resident, Department of Psychiatry, Kaiser Permanente Medical Center, Oakland, CA. His experience also includes years in private practice and numerous clinical settings.

Interested in counseling? social work?  
improving your communication skills?  
a degree in Interpersonal Communications?



## Psychology 52 Peer Counseling

Transferable to CSU

**5 great reasons to take this POLS 6!**

- 1. It's rewarding.** You help people solve real problems.
- 2. It's interesting.** Every case is different.
- 3. It pays off.** In your work, school, and relationships.
- 4. It's great for your resume,** demonstrating your teamwork.
- 5. It's changing the world.** Growing numbers of people solve conflict peacefully and cooperatively.

**Great reasons! Great skills! Great class!****Political Science 6****Introduction to Conflict Resolution**

You can also register for AJ 6, CMUN 6 or PSYC 6.

(AJ 6 provides elective credit for AJ majors)

This class fulfills Gavilan general education and CSU transfer requirements.

Sect. Type Room Instructor Hrs. Units Days Begin-End Footnotes

**PSYC 5 Self-Assessment and Career Development**

**Advisory:** Eligible for English 250 and English 260.  
**Transferable:** CSU; CSU-GE: E2; GAV-GE: E2

A course designed to assist the student in learning more about personal values, personality, interests, exploration of career choice, and occupational opportunities through the use of various personal assessment instruments. The delivery options for this course include online and self-paced formats. This course is also listed as GUID 1.

4806 LEC OE001 TENNEY L 2.30 2.0 Tu 1255P-0200P 25 89  
 TENNEY L Th 1255P-0155P

4807 ONLINE SHARBONEAU 2.30 2.0 DHR 0000-0000 25 38 89  
 This online class will be delivered entirely over the internet. After enrolling, start the class by going to <http://www.gavilan.edu/disted/>, click on your class link, and email the instructor at [rsharboneau@gavilan.edu](mailto:rsharboneau@gavilan.edu). Students who have not begun the class or contacted the instructor by 5 pm on Monday, February 5 will be dropped from the class.

4808 ONLINE SHARBONEAU 2.30 2.0 DHR 0000-0000 25 38 89  
 This online class will be delivered entirely over the internet. After enrolling, start the class by going to <http://www.gavilan.edu/disted/>, click on your class link, and email the instructor at [rsharboneau@gavilan.edu](mailto:rsharboneau@gavilan.edu). Students who have not begun the class or contacted the instructor by 5 pm on Monday, February 5 will be dropped from the class.

**PSYC 6 Introduction to Conflict Resolution**

**Advisory:** English 250 and English 260.  
**Transferable:** CSU; CSU-GE: D7; GAV-GE: D2

Introduction to Conflict Resolution introduces students to conflict resolution and mediation. Integrating theory and practice, students will assess core concepts about the causes and resolution of conflict, and will practice communication skills for conflict resolution. Students will examine how ethnicity, gender, and class affect power in conflict situations. They will be able to formulate appropriate conflict resolution strategies, and will develop and practice various basic co-mediation skills. This course has the option of a letter grade or credit/no credit. This course is also listed as AJ 6 and POLS 6 and CMUN 6.

4809 LEC SS205 HALPERL 3.40 3.0 MW 0945A-1110A 25

**PSYC 22 Field Work and Service**

**Required:** Learning contracts must be filled out and signed by the student and the supervising instructor.  
**Transferable:** CSU

Supervised field work within the college and with local agencies. Students serve in useful group activities in leadership roles prescribed for them by faculty or community agencies. A maximum of six units may be completed. This is a credit/no credit course.

4810 FEX SS109 HINNG 3.40 1.0 DHR 0000-0000 21

**PSYC 23 Independent Study**

**Required:** The study outline prepared by the student and the instructor must be filed with the department and the dean.  
**Transferable:** CSU

Designed to afford selected students specialized opportunities for exploring areas at the independent study level. The courses may involve extensive library work, research in the community, or special projects. May be repeated until six units of credit are accrued. This course has the option of a letter grade or credit/no credit.

4811 IND SS109 HINNG 6.40 2.0 DHR 0000-0000 22

**PSYC 27 Contemporary Leadership**

**Advisory:** Eligible for English 250 and English 260.  
**Transferable:** CSU; GAV-GE: E2

A cross-disciplinary approach to the theory and practice of leadership. Includes effective communication styles including issues related to gender and culture. Class includes topics on ethics, power, and how to run effective meetings including the use of parliamentary procedure. Skills directly applicable to work, personal and college environments. May be repeated for a maximum of 10 units. Also listed as POLS 27.

4812 L/L LS101 STEWART J 4.60 3.0 TuTh&2 0810A-0930A 25

Sect. Type Room Instructor Hrs. Units Days Begin-End Footnotes

**PSYC 52 Peer Counseling**

**Advisory:** Eligible for English 250 and English 260.  
**Transferable:** CSU

An overview of the principles, skills, and methods used in peer counseling. Course emphasizes using communication skills, goal setting, intervention techniques and evaluation for peer counselors and others.

4813 LEC OE002 LISTERT 2.30 2.0 W 0230P-0435P

**Public Speaking: see Communications**

**REAL ESTATE**

**RE 160 Real Estate Principles**

**Advisory:** English 250, English 260 and Mathematics 205.  
**Transferable:** CSU

The fundamental course covering an introduction to the field of real estate. Provides understanding, background and terminology necessary for advanced specialized courses. Will meet requirements for the Real Estate Sales License.

6174 LEC SS205 LITTIG A 3.40 3.0 M 0630P-0940P

 **RE 167 Real Estate Economics**

**Advisory:** Real Estate 160  
**Transferable:** CSU

An introduction to the causes and effects of value fluctuations in real estate, the nature of land economics and development of residential, commercial, industrial, recreational and special purpose properties. The student will study the principles of capitalism, community growth patterns, taxes, and other related economic concepts. This course may be used for the California Broker's License.

6175 LEC BU120 FRIMANN S 3.40 3.0 Th 0630P-0940P

**Skin Care: see COS 220, 221**

**SOCIAL SCIENCES, GENERAL**

 **SSCI 270B Introduction to the Social Sciences**

**Prerequisite:** Completion of English 420 with a grade of 'C' or better or Assessment recommendation.

**Advisory:** Eligible for English 250.  
**Transferable:** No; GAV-GE: A3

An introduction to key concepts, principles, frameworks and issues in the major social science disciplines of psychology, sociology, and anthropology for students wishing to get a broad overview. Development of techniques and practice in research, reasoning, writing, topical reading, and critical analytical skills germane to the understanding of individuals, groups, and societies will be emphasized so students will build skills to think critically about contemporary policies and practices of groups, societies, and governments. This course has the option of a letter grade or credit/no credit.

4833 LEC SS110 HIRASUNA S 3.40 3.0 MW 1120A-1245P

**Be Aware**

You MAY NOT take courses that overlap (courses that meet at the same day and time)!

Sect. Type Room Instructor Hrs. Units Days Begin-End Footnotes

**SOCIOLOGY**

**SOC 1A Introduction to Sociology**

**Advisory:** Eligible for English 250 and English 260.

**Transferable:** CSU; UC; CSU-GE: D0; IGETC: 4J; GAV-GE: D2; CAN: SOC 2

Analysis of the structure and dynamics of human society focusing on the development of culture, the socialization process, group behavior, social inequality, deviance, sexism, racism, and ageism, major social institutions, and human ecology. Emphasizes contemporary American society.

4814	LEC	SS214	MOORE M	3.40	3.0	TuTh	0945A-1110A
4815	LEC	HOL1	BALES N	3.40	3.0	MW	1120A-1245P Above class meets at the Hollister Briggs site
4816	LEC	SS210	VILLARREAL A	3.40	3.0	TuTh	0230P-0405P

**SOC 1B Introduction to Sociology: Social Problems**

**Advisory:** Sociology 1A

**Transferable:** CSU; UC; CSU-GE: D0; IGETC: 4J; GAV-GE: D2; CAN: SOC 4

Sociology 1B is a course centering on the application of sociological concepts to the analysis of human ecology, social movements, social change, deviance and other selected social problems. Emphasis is placed on the study and analysis of problems in contemporary American society.

4817	LEC	SS205	MOORE M	3.40	3.0	TuTh	1120A-1245P
------	-----	-------	---------	------	-----	------	-------------

**SOC 3 Sociology of Minorities**

**Advisory:** Eligible for English 250 and English 260.

**Transferable:** CSU; UC; CSU-GE: D0; IGETC: 4J; GAV-GE: D2, F

The study of selected American ethnic/"racial" minorities from a sociohistorical perspective. Focus is on understanding the reasons for, and the solutions to, problems relating to majority/minority relations.

4818	LEC	SS205	CERVANTES E	3.40	3.0	MW	1120A-1245P
------	-----	-------	-------------	------	-----	----	-------------

**SOC 4 Sociology of Women and Men**

**Advisory:** Eligible for English 250 and English 260.

**Transferable:** CSU; UC; CSU-GE: D0, D4; IGETC: 4J; GAV-GE: D2

Analysis of the nature of women's and men's traditional and changing roles in society including development of women's and men's potential, relationships in marriage, influence of mass media, employment practices, legal provisions and women's and men's liberation.

6176	LEC	HOL5	FAUTT M	3.40	3.0	M	0630P-0940P Above class meets at the Hollister Briggs site
------	-----	------	---------	------	-----	---	---

**SOC 10 Mass Media and Society**

**Advisory:** English 250, English 260

**Transferable:** CSU; UC; CSU-GE: C2, D0; IGETC: 4J; GAV-GE: C2, D2

This course helps us understand the 20th century revolution in mass media by focusing on the history, economics and social impact of the newspaper, book publishing, magazine, film, television, public relations, advertising and music industries. We will study audience, propaganda and mass communication theory; we will discuss new technology, ethnic media in the U.S., ethical issues and attempts to regulate or control the media. Honors students will complete more in-depth analysis of media issues, and will finish a media-related research project. This course is also listed as JOUR 10. This course has the option of a letter grade or credit/no credit.

4819	LEC	AL101	VILLARREAL A	3.40	3.0	TuTh	1255P-0220P
------	-----	-------	--------------	------	-----	------	-------------

Sect. Type Room Instructor Hrs. Units Days Begin-End Footnotes

**SOC 21 Marriage and the Family**

**Advisory:** Eligible for English 250 and English 260.

**Transferable:** CSU; CSU-GE: E2; GAV-GE: E2

Survey of information on preparation for marriage, including dating, courtship, engagement, mate selection, adjustment and parenthood. Time will also be spent on the study of families and how they function.

4820	LEC	SS110	HINN G	3.40	3.0	TuTh	0945A-1110A
4821	LEC	OE001	NAVA S	3.40	3.0	MW	1255P-0220P
6177	LEC	SS214	FAUTT M	3.40	3.0	Tu	0630P-0940P

**SPANISH**

**SPAN 1A Elementary Spanish**

**Transferable:** CSU; UC; CSU-GE: C2; GAV-GE: C2; CAN: SPAN 2, SPAN SEQ. A

Beginning course with emphasis on understanding and speaking Spanish; introduction to reading and writing Spanish. This course will also introduce students to Hispanic culture and institutions.

4822	L/L	HU105	MARQUES A	5.60	5.0	MTuWTh&2.8	0820A-0930A
4823	L/L	HOL2	PEREZ D	5.60	5.0	MTuWTh&2.8	0830A-0940A Above class meets at the Hollister Briggs site
4824	L/L	HU105	PEREZ D	5.60	5.0	MTuWTh&2.8	1255P-0205P

**SPAN 1B Elementary Spanish**

**Advisory:** Spanish 1A or equivalent.

**Transferable:** CSU; UC; CSU-GE: C2; IGETC: 6A; GAV-GE: C2; CAN: SPAN 4, SPAN SEQ. A

Continuation of Spanish 1A. Further development of the four skills of understanding, speaking, reading and writing Spanish. This course will continue to emphasize the study of Hispanic culture and institutions.

4825	L/L	HOL6	PEREZ D	5.60	5.0	MTuWTh&2.8	0945A-1055A Above class meets at the Hollister Briggs site
4826	L/L	HU105	MARQUES A	5.60	5.0	MTuWTh&2.8	1120A-1230P

**SPAN 2B Intermediate Spanish**

**Advisory:** Spanish 2A or equivalent.

**Transferable:** CSU; UC; CSU-GE: C2; IGETC: 3B; GAV-GE: C2; CAN: SPAN 10, SPAN SEQ. B

Review of basic structures and grammar with greater emphasis on vocabulary and idioms. Introduction to literature as it reflects the characteristics of Hispanic societies. Greater emphasis on composition as a medium of expression.

4827	L/L	HU105	MARQUES A	5.60	5.0	MTuWTh&2.8	0945A-1055A
------	-----	-------	-----------	------	-----	------------	-------------

**SPAN 8A Conversational Spanish**

**Transferable:** CSU; GAV-GE: C2

This course is a beginning Spanish course, focusing on the Spanish sound system, basic grammar and vocabulary, and cultural elements. Although emphasis is on listening and speaking, basic reading and writing skills will be developed.

6178	LEC	HOL1	POLO I	3.40	3.0	M	0600P-0910P Above class meets at the Hollister Briggs site
6179	LEC	MHG11	LEMO S C	3.40	3.0	M	0630P-0940P Above class meets at Morgan Hill Community site

- SUMMER 2007 - **STUDY AND TRAVEL IN SPAIN** - JUNE 3-30 -

Attend the Orientation: Saturday, Feb 24 at 9:30 am in HU105 on the Gilroy main campus.

Earn up to 5 units. Study the language and culture while living with a host family in Seville, Spain.

For more information visit the website at [www.gavilan.edu/spanish](http://www.gavilan.edu/spanish), call Albert Marques at 408-848-4794 or email [amarques@gavilan.edu](mailto:amarques@gavilan.edu)

Sect. Type Room Instructor Hrs. Units Days Begin-End Footnotes

**SPAN 8B Conversational Spanish**

Advisory: Spanish 8A or equivalent.  
Transferable: CSU; GAV-GE: C2

This course requires knowledge of Spanish pronunciation, basic vocabulary, and present tense grammar. More advanced grammar and vocabulary, and cultural elements will be taught in the development of listening, speaking, basic reading and writing skills.

6180	LEC	HU105	LEMOS C	3.40	3.0	W	0600P-0910P
------	-----	-------	---------	------	-----	---	-------------

**SPAN 12A Spanish for Spanish Speakers**

Advisory: Basic Spanish reading and writing skills.  
Transferable: CSU; UC; CSU-GE: C2; GAV-GE: C2, F

Through comparative analysis of selected literary works, the course develops an awareness of cultural and literary contributions from Mexico and other Spanish speaking societies. The course is taught in Spanish with emphasis on composition as a medium of expression.

4828	ONLINE	SCHMIDT E	8.40	5.0	DHR	0000-0000	38
------	--------	-----------	------	-----	-----	-----------	----

This online class will be delivered entirely over the internet. After enrolling, start the class by going to <http://www.gavilan.edu/disted/>, click on your class link, and email the instructor at [eschmidt@gavilan.edu](mailto:eschmidt@gavilan.edu). Students who have not begun the class or contacted the instructor by 5 pm on Monday, February 5 will be dropped from the class.

**SPAN 12B Spanish for Spanish Speakers**

Advisory: Basic Spanish speaking skills.  
Transferable: CSU; UC; CSU-GE: C2; GAV-GE: C2, F

Continuation of 12A; through comparative analysis of selected literary works, the course develops an awareness of cultural and literary contributions from Mexico and other Spanish speaking societies. The course is taught in Spanish with emphasis on composition as a medium of expression.

4829	ONLINE	PEREZ D	8.40	5.0	DHR	0000-0000	
------	--------	---------	------	-----	-----	-----------	--

This online class will be delivered entirely over the internet. After enrolling, start the class by going to <http://www.gavilan.edu/disted/>, click on your class link, and email the instructor at [dperez@gavilan.edu](mailto:dperez@gavilan.edu). Students who have not begun the class or contacted the instructor by 5 pm on Monday, February 5 will be dropped from the class.

**SPAN 23 Independent Study**

Required: The study outline prepared by the student and the instructor must be filed with the department and the dean.  
Transferable: CSU

Designed to afford selected students specialized opportunities for exploring areas at the independent study level. The courses may involve extensive library work, research in the community, or special projects. May be repeated until six units of credit are accrued. This course has the option of a letter grade or credit/no credit.

4830	IND	HU108	PEREZ D	6.80	2.0	DHR	0000-0000	21
4831	IND	HU110	MARQUES A	6.80	2.0	DHR	0000-0000	21
4832	IND	HU108	PEREZ D	3.40	1.0	DHR	0000-0000	
6181	IND	HU103	MAGUNA J	6.80	2.0	Tu&6.8	0630P-0920P	21

**Speech: see Communications**  
**Statistics: see Mathematics**

**Don't forget**

A counselor's signature is required if you take over 17.99 units (spring/fall) or over 5.99 units (summer).

You do not need a counselor's signature to register for a class with a prerequisite that was successfully completed at Gavilan.

Sect. Type Room Instructor Hrs. Units Days Begin-End Footnotes

**THEATRE ARTS / TELEVISION**

**THEA 3 El Teatro Campesino**

Advisory: Eligible for English 250 and English 260.  
Transferable: CSU; UC; CSU-GE: C1; GAV-GE: C1

Reading, viewing and discussing the work of writer/director Luis Valdez and El Teatro Campesino (The Farmworkers Theatre) is the focus of this course. It traces the historical development of the theatrical company from its creation in 1965 to the present. Students will read acts, plays and view theatrical productions performed by El Teatro Campesino. This course has the option of a letter grade or credit/no credit.

4835	LEC/online	CARDINALLI J	3.40	3.0	DHR	0000-0000	11 13
------	------------	--------------	------	-----	-----	-----------	-------

03/19/07-05/25/07 This HYBRID lecture/online class will be delivered partially over the internet. See the online syllabus for details. <http://www.gavilan.edu/disted/>.  
This class will require attendance at three (3) theatre productions during the semester.

**THEA 4 Oral Reading**

Advisory: Eligible for English 250 and English 260.  
Transferable: CSU; UC; CSU-GE: C1; GAV-GE: C1

An introduction to the analysis, preparation and dramatic reading of literature, including classical and contemporary prose, poetry and drama. Students prepare, analyze and orally present and interpret great works of drama and literature for an audience. This course is also listed as CMUN 2.

4836	LEC	L1144	STAFF	3.40	3.0	TuTh	0945A-1110A	25
------	-----	-------	-------	------	-----	------	-------------	----

**THEA 7 Introduction to Theatre**

Transferable: CSU; UC; CSU-GE: C1; IGETC: 3A; GAV-GE: C1

This learning experience examines how theatre productions are staged and created. Elements of theatrical production including: writing, producing, directing, designing, and acting will be explored.

4837	LEC	TH125	HAEHL J	3.40	3.0	TuTh	0945A-1110A
------	-----	-------	---------	------	-----	------	-------------

**THEA 11 Dance and Movement for the Theatre**

Transferable: CSU; UC; GAV-GE: C1

Introduction to basic dance, period movement, stage combat and mime techniques suitable for the performing arts. This course has the option of a letter grade or credit/no credit. May be repeated three times for credit.

4838	L/L	APE101	STAFF	3.30	2.0	MW	1120A-1245P
------	-----	--------	-------	------	-----	----	-------------

**THEA 12A Acting: History and Practice**

Transferable: CSU; UC; CSU-GE: C1; GAV-GE: C1; CAN: DRAM 8

An introduction to the historical development of acting as a practice of human cultural expression. Students will acquire a vocabulary for theatre performance as an art form and analyze dramatic works in a historical context. Practice of basic acting concepts, character analysis, preparation and performances of monologues and scenes will be required in the course.

4839	L/L	TH125	HAEHL J	5.60	3.0	TuTh	1120A-0125P
------	-----	-------	---------	------	-----	------	-------------

**THEA 12B Acting Techniques**

Advisory: Theatre Arts 12A.  
Transferable: CSU; UC; GAV-GE: C1

Techniques for creating characterizations for performance. Various acting approaches will be examined through research, discussion and acting exercises. This course has the option of a letter grade or credit/no credit. May be repeated two times for credit.

4840	L/L	TH125	HAEHL J	4.40	2.0	TuTh	1120A-0125P
------	-----	-------	---------	------	-----	------	-------------

Sect. Type Room Instructor Hrs. Units Days Begin-End Footnotes

**THEA 13A Actor's Workshop**

Transferable: CSU; UC; GAV-GE: C1

Audition, rehearsal and performance of a theatrical production for public performance.

6182	LAB	TH125	HAEHL J	10.10	3.0	MTuWTh	0630P-0940P	11
------	-----	-------	---------	-------	-----	--------	-------------	----

**THEA 13B Actor's Workshop**

Transferable: CSU; UC; GAV-GE: C1

Audition, rehearsal and performance of a theatrical production for public performance.

6183	LAB	TH125	HAEHL J	10.10	3.0	MTuWTh	0630P-0940P	11
------	-----	-------	---------	-------	-----	--------	-------------	----

**THEA 13C Actor's Workshop**

Advisory: THEA 13B.

Transferable: CSU; UC; GAV-GE: C1

Audition, rehearsal and performance of a theatrical production for public performance.

6184	LAB	TH125	HAEHL J	10.00	3.0	MTuWTh	0630P-0940P	11
------	-----	-------	---------	-------	-----	--------	-------------	----

**THEA 13D Actor's Workshop**

Advisory: Theatre Arts 13C

Transferable: CSU; UC; GAV-GE: C1

Audition, rehearsal and performance of a theatrical production for public performance.

6185	LAB	TH125	HAEHL J	10.10	3.0	MTuWTh	0630P-0940P	11
------	-----	-------	---------	-------	-----	--------	-------------	----

**THEA 14 Stage Production**

Advisory: Eligible for English 250 and English 260.

Transferable: CSU; UC; GAV-GE: C1

An individualized course in technical theatre production for the performing arts. Areas of study include: scenery, lighting, props, costumes, sound, make-up, public relations/box office management or stage management. May be repeated until a maximum of 9 units are accrued.

4841	LAB	TH125	HAEHL J	3.40	1.0	MW	1255P-0220P
4885	LAB	TH125	HAEHL J	3.40	2.0	MW&3.4	1255P-0220P
4886	LAB	TH125	HAEHL J	3.40	3.0	MW&6.7	1255P-0220P

**THEA 16 Introduction to Television**

Advisory: Eligible for English 250 and 260.

Transferable: CSU; GAV-GE: C1

An introductory course on the history of television as a major communications tool. Students will learn skills for effective script writing, production techniques, and post-production procedures.

4842	LEC	LI144	GUERRAZZID	3.40	3.0	MW	0945A-1110A
------	-----	-------	------------	------	-----	----	-------------

**THEA 17A Television and Video Workshop**

Advisory: Theatre Arts 16 Intro to TV or consent of instructor.

Transferable: CSU; GAV-GE: C1

An introduction to television and video technology, including pre-production, production and post-production techniques such as: camera work, studio equipment, lighting, audio plus off-line and on-line editing.

4843	L/L	LI144	FRAZIER J	5.70	3.0	TuTh	1255P-0325P
------	-----	-------	-----------	------	-----	------	-------------

**THEA 17B Television and Video Workshop**

Advisory: Completion of Theatre Arts 17A.

Transferable: CSU; GAV-GE: C1

Emphasis placed on production and post-production techniques in video production. Student knowledge and skills are increased by participating in live to tape projects. May be repeated twice for credit.

4844	LEC	LI144	FRAZIER J	5.70	3.0	TuTh	1255P-0325P
------	-----	-------	-----------	------	-----	------	-------------

**Footnotes contain valuable information pertaining to your class selection. Footnotes follow class listings.**



See live Theatrical productions at the Playhouse in San Juan Bautista!

**Instructor: Joe Cardinali**

March 19 - May 25

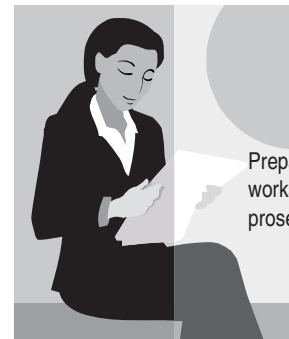

**THEA 4** 3 units  
**Oral Reading**

Prepare, analyze and orally present and interpret great works of drama including classical and contemporary prose, poetry and drama and literature for an audience!

Satisfies the CSU transfer requirement for Area C-1 and the Gavilan College GE requirement for Area C-1

also listed as CMUN 2

**THEA 12A**  
**Acting: History & Practice**

**THEA 12B**  
**Acting Techniques**

The acting class will focus on acting techniques used in performing classical theater. We will study and perform scenes & monologues from various periods in Theater History including classical Greece, the English Renaissance and the Neoclassic period in France.



Transfer to:  
CSU; UC;  
GAV-GE: C1



*Enter the world of  
live entertainment!!!*

**THEA 13 A-D**  
**Actor's Workshop**  
*presents*

**Lend Me a Tenor** by Ken Ludwig

This lively & zany farce is written in the style of the classic Marx Brother films. Fun and laughs for everyone!

Transfer to:  
CSU; UC;  
GAV-GE: C1

*Artistic Direction by John Lawton Haehl*

*For more information email jlawtonhaehl@gavilan.edu*

Sect. Type Room Instructor Hrs. Units Days Begin-End Footnotes

**THEA 19 Television and Film Acting**

Transferable: CSU; UC; GAV-GE: C1

Theory and practice of acting for film and television. Students will learn basic performance techniques for the camera. Learning experiences include projects in broadcasting, reporting, commercials, public service announcements (psa), comedy and drama. This course has the option of a letter grade or credit/no credit. May be repeated three times for credit.

4845 L/L LI144 ABAD M 5.70 3.0 MW 1120A-1245P

**THEA 20 Introduction to Scriptwriting**

Advisory: English 250

Transferable: CSU

An introductory course on script development, writing and formatting for broadcast television and film production. This course has the option of a letter grade or credit/no credit.

4894 LEC ONLINE ABAD M 3.40 3.0 DHR 0000-0000 11 38

 03/19/07-05/25/07 This online class will be delivered entirely over the internet. After enrolling, start the class by going to <http://www.gavilan.edu/disted/>, click on your class link, and email the instructor at [mabad@gavilan.edu](mailto:mabad@gavilan.edu). Students who have not begun the class or contacted the instructor by 5 pm on the 3rd day of class will be dropped from the class.

**THEA 22 Field Work and Service**

Required: Learning contracts must be filled out and signed by the student and the supervising instructor.

Transferable: CSU

Supervised field work within the college and with local agencies. Students serve in useful group activities in leadership roles prescribed for them by faculty or community agencies. A maximum of six units may be completed. This is a credit/no credit course.

4846 FEX TH125 ABAD M 3.40 1.0 DHR 0000-0000 21

**THEA 23 Independent Study**

Required: The study outline prepared by the student and the instructor must be filed with the department and the dean.

Transferable: CSU

Designed to afford selected students specialized opportunities for exploring areas at the independent study level. The courses may involve extensive library work, research in the community, or special projects. May be repeated until six units of credit are accrued. This course has the option of a letter grade or credit/no credit.

4847 IND TH125 ABAD M 3.40 1.0 DHR 0000-0000 22

4848 IND TH125 ABAD M 6.80 2.0 DHR 0000-0000 22

4849 IND TH125 FRAZIER J 3.40 1.0 DHR 0000-0000 22

4850 IND TH125 FRAZIER J 6.80 2.0 DHR 0000-0000 22

4851 IND TH125 HAEHL J 3.40 1.0 DHR 0000-0000 22

4852 IND TH125 HAEHL J 6.80 2.0 DHR 0000-0000 22

**THEA 98 Special Topics – GavTV Channel 18**

Transferable: CSU

Special topics courses examine current problems or issues of interest to students within a specific discipline area. For topical content information, consult with the appropriate department chairperson. For transfer status, check with a counselor. This course may have the option of a letter grade or credit/no credit.

4853 LEC OE003 ABAD M 1.00 1.0 Tu 1110A-1200P

4854 LEC OE003 ABAD M 2.30 2.0 Tu 1110A-1200P

**Campus under construction  
ROOM NUMBERS MAY CHANGE!**

Check room numbers online before your first class.

Sect. Type Room Instructor Hrs. Units Days Begin-End Footnotes

**VOCATIONAL PREPARATION FOR DISABLED**

**AE 600 Vocational Training I**

Transferable: No

Prevocational skills for adults with impaired cognitive functioning. Entry level work preparation is emphasized. Skills taught include basic work routine orientation, communication skills, job ability assessment, and self-management skills.

4010 LAB LI204 FRANKLIN L 33.80 .0 DHR 0000-0000 31 75

4011 LAB HOPE-G MERRILL BROWN C SATO K 33.80 .0 DHR 0000-0000 31 63 75

See Footnote: Above class meets Off Campus

4012 LAB HOPE-H BROWN C 33.80 .0 DHR 0000-0000 31 51 75

See Footnote: Above class meets Off Campus

4013 LAB LI171 SATO K 2.00 .0 TuTh 0900A-1000A 31 75

4014 LAB LI117 MERRILL BROWN C 7.00 .0 W 0900A-0400P 31 75

4015 LAB MHG10 MERRILL 4.00 .0 M 0910A-0100P 31

4016 LAB GY131G SATO K 2.00 .0 TuTh 1010A-1110A 31 75

4017 LAB APE120 BROWN C APE121 BROWN C 2.00 .0 TuTh 1120A-1225P 31 75

**AE 602 Vocational Training III**

Transferable: No

Practical training and on-the-job work experience for students with disabilities. This course also provides preparation for entry level employment utilizing a number of work alternatives and settings.

4018 LAB HOPE-H SATO K 33.80 .0 DHR 0000-0000 31 51 75

See Footnote: Above class meets Off Campus

4019 LAB LI204 FRANKLIN L 33.80 .0 DHR 0000-0000 31 75

4020 LAB HOPE-G BROWN C MERRILL 33.80 .0 DHR 0000-0000 31 63 75

See Footnote: Above class meets Off Campus

**AE 603 Vocational Training IV**

Transferable: No

AE 603 is a job readiness course which provides opportunities for individuals with disabilities to participate in service-learning activities and job readiness training leading to job development and placement in a community setting.

4023 L/L SS216 FRANKLIN L 3.40 .0 W 0945A-1255P 31 75

**AE 605 Vocational Training VI**

Transferable: No

This course is designed for students with disabilities. The purpose of this course is to improve the student's ability to participate in the community, by increasing independence through acquisition of survival vocabulary, structured practice in functional reading utilizing phonics and content recognition, and increased enjoyment in reading for pleasure. Opportunities will be provided for oral reading of high interest-low reading level life experience stories written or revised specifically for adults with limited reading skills.

4024 L/L BU117 BROWN C 1.50 .0 Th 1255P-0220P 31 75

**AE 613 Independence Training IV**

Transferable: No

This course is designed for students with disabilities. The purpose of this course is to improve the student's ability to build math competencies related to independence in daily living and the work site. The focus of the class is basic computation, consumer awareness, money management, banking and purchasing.

4025 L/L BU117 BROWN C 1.50 .0 Tu 1255P-0220P 31 75

**AE 636 Adapted Physical Education**

**Advisory:** Students must be able to document a physical disability.  
**Transferable:** No

An individualized program of adapted physical education activities designed to meet the needs of students who are physically limited or disabled. The course assists in the development and appreciation of physical activity as a regular planned contribution to one's overall well-being. This course is for the non-matriculating student, is not graded and is without college credit.

4026	LAB	GY999	ELLIS D	3.40	.0	DHR	0000-0000	31 75 90
4027	LAB	LOADCS	CRETIN A	3.40	.0	MW	0930A-1055A	70 31 75
See Footnote: Above class meets Off Campus								
4028	LAB	LOADCS	CRETIN A	3.40	.0	TuTh	0945A-1110A	70 31 75
See Footnote: Above class meets Off Campus								
4029	LAB	LOADCS	MARINGER J	1.00	.0	F	1000A-1100A	70 31 75
02/23/07 - 05/25/07 See Footnote: Above class meets Off Campus								
4030	LAB	HOLLCC	CRETIN A	3.40	.0	MW	1120A-1245P	68 31 75
See Footnote: Above class meets Off Campus								

**Word Processing: see CSIS**

**WORK EXPERIENCE**

**CWE 190 Occupational Work Experience**

**Required:** Declared vocational major. Concurrent enrollment in seven or more units (including CWE units, except for summer school. For summer school, enrollment in one other class is required). Minimum 2.00 G.P.A.

**Transferable:** CSU

Occupational work experience for students who have a job related to their major. A training plan is developed cooperatively between the employer, college and student. (CR/NC grading) 75 hours per semester paid work = 1 unit. 60 hours non-paid (volunteer) work per semester = 1 unit. May be taken for a maximum total of 16 units.

4270	WEX	BU125	KERR L	5.60	1.0	TBA	0000-0000	16
4271	WEX	BU125	KERR L	11.30	2.0	TBA	0000-0000	16
4272	WEX	BU125	KERR L	16.90	3.0	TBA	0000-0000	16
4273	WEX	BU125	KERR L	22.50	4.0	TBA	0000-0000	16

**CWE 192 General Work Experience Education**

**Required:** Concurrent enrollment in seven or more units (including CWE units, except for summer school. For summer school, enrollment in one other class is required) Minimum 2.00 G.P.A.

**Transferable:** CSU

General work experience for students who have a job unrelated to their major. General work experience is supervised employment which is intended to assist students in acquiring desirable work habits, attitudes and career awareness. A training plan is developed cooperatively between the employer, college and student. (CR/NC grading) 75 hours per semester paid work = 1 unit. 60 hours non-paid (volunteer) work per semester = 1 unit. May be taken for a maximum of 16 units.

4274	WEX	BU125	KERR L	3.40	1.0	TBA	0000-0000	16
See Footnote: Above class meets Off Campus								
4275	WEX	BU125	KERR L	6.40	2.0	TBA	0000-0000	16
See Footnote: Above class meets Off Campus								
4276	WEX	BU125	KERR L	10.10	3.0	TBA	0000-0000	16
See Footnote: Above class meets Off Campus								

**FACULTY Profile**



**Dr. John Lawton Haehl:**

John Lawton Haehl is a fifth generation Californian and a proud graduate of the San Francisco Public Unified School System. Dr. Haehl holds BAs in English and Theatre from UC Berkeley where he participated in numerous productions as a designer and performer. While working on his Doctorate at UC Davis, he received many awards including the Professors for the Future Honors Fellowship from Graduate Studies, as well as the prestigious Outstanding Teaching Award from the Academic Senate. Dr. Haehl has taught courses in theatre and costume design at UCD, Santa Rosa Junior College, Solano Community College, and The Sewing Workshop in San Francisco.

An award winning designer, Dr. Haehl's portfolio includes productions for UC Berkeley, UC Davis, Solano Community Theatre, Napa Valley Rep., Solo Opera Company, the San Francisco Actors Ensemble and SRT (Santa Rosa Junior College). This year he received an Elly award for his designs for Disney's Beauty & the Beast, and was also awarded an Arty Award for his work with Solano Youth Theatre. Dr. Haehl is delighted to join the Gavilan community and has recently moved to the Gilroy area with his wife, Kristina.



*Be a part of the cameras, lights, action. Enroll in:*

- THEA 14** Stage Production
- THEA 16** Introduction to Television
- THEA 17A/B** Television and Video Workshop
- THEA 19** Television and Film Acting



**Get Involved!**  
Sign up for

**THEA 98 - GAVTV 18**

- Learn all aspects of TV programming
- Be a studio production crew member
- Produce and create your own GAV-TV program

2 Sections - see class listing on page 118.

For more information call Executive Producer Marilyn Abad-Cardinalli at 408-848-4764 or visit [www.gavilan.edu](http://www.gavilan.edu) click on GavTV 18.



- Footnote #1 Tutorial help is offered for this class. See your instructor.
- Footnote #2 Make appointment with Disability Resource Center (DRC) Office.
- Footnote #3 Locational painting sessions followed by functional critiques.
- Footnote #4 Students should consider concurrent enrollment in CGD 110 lab class for 1 unit requiring 3 hours of additional lab per week.
- Footnote #5 Basic hand tools required. Details at the first class meeting.
- Footnote #6 This class is part of the High Step program. It will be offered at Ann Sobrato High School. Check online footnote for location. This class is open to all students. For more information, see a Gavilan counselor.
- Footnote #7 Orientation required. Schedule available in BU 110.
- Footnote #8 Morgan Hill Community Center/Computer Lab hours (TBA).
- Footnote #9 Gavilan Business/Computer Lab hours in BU 110 for students are: Mon/Wed/Thur & FRI from 9 am - 2 pm & Tues from 9 am - 3 pm & Tues Evening from 6:00 - 9:25 pm.
- Footnote #10 Hollister Briggs/Computer Lab hours (TBA).
- Footnote #11 Short-term classes meet on specified dates.
- Footnote #12 Recommended for students with verified learning disability.
- Footnote #13 This HYBRID lecture/online class will be delivered partially over the internet. See the online syllabus for details. <http://www.gavilan.edu/disted/>.
- Footnote #14 In order to obtain Field Work Credit for the Occupational Work Experience placement, students must enroll in this class.
- Footnote #15 The instructor will be using and supporting a TI-83 Plus graphing calculator in all classroom demonstrations.
- Footnote #16 Mandatory course orientation will be conducted Tuesday February 20 or Friday February 23, 2007 from 12-1 p.m. in SC 154N. Students need to attend one of the two meetings. Please contact Lynda Kerr, CWE Coordinator at (408) 846-4993 for more information.
- Footnote #17 Meets at Anzar High School, 2000 San Juan Hwy., San Juan Bautista.
- Footnote #18 This class has a department exam on Saturday, May 12, 2007 from 9 -11 am.
- Footnote #19 Please contact Debbie Roderick at the Tutoring Center in LI 116 or call (408) 848-4838 upon enrolling in this class.
- Footnote #20 This course is pending approval for general education (CSU-GE and IGETC). Please see a counselor for more information.
- Footnote #21 Field Work and Service: May be repeated three times for credit.
- Footnote #22 Independent Study: The Dean must approve the study outline prepared by the student and instructor. May be repeated three times for credit.
- Footnote #23 Students must purchase a uniform, lab coat, shoes and a skin care kit; (approximately \$500). This does not include books and classroom materials.
- Footnote #24 Students must furnish gloves and safety glasses... approximately \$20.
- Footnote #25 Dually listed course. Refer to Gavilan College Catalog.
- Footnote #26 Students will pay approximately \$20 in ball/equipment rental.
- Footnote #27 Students must purchase a cosmetology kit, manikin and uniform (approximately \$500). This does not include books and classroom materials.
- Footnote #28 Meets at Gavilan College Aviation Department, 490 Skylane Drive, Hollister Airport, Hollister.
- Footnote #29 This course is co-taught by two instructors.
- Footnote #30 Class meets reduced contact hours for reduced units.
- Footnote #31 Open entry-open exit.
- Footnote #32 \$12 course material fee. Additional \$3.00 due upon completion for certification card.
- Footnote #33 Classes meet 1/2 regular hours, receiving .5 unit value.
- Footnote #34 This class is taught in Spanish. (Esta clase sera enseña en español.)
- Footnote #35 "&" means additional lab hours are required.
- Footnote #36 This class is part of a learning community. You must enroll in both courses.
- Footnote #37 This class meets seven Fridays, February 23 – April 6, 2007. There is only ONE Saturday meeting (March 3, 2007) that will meet in LI 116.
- Footnote #38 This online class will be delivered entirely over the Internet. After enrolling, start the class by going to <http://www.gavilan.edu/disted/>, click on your class link and email your instructor.
- Footnote #39 \*\*\*\*\*
- Footnote #40 This class will be taught in English and Spanish for ESL students. (Esta clase se enseña en inglés y español.)
- Footnote #41 Meets at the Veteran's Memorial Bldg., 649 San Benito St., Hollister, room 218.
- Footnote #42 There will be an in-person orientation the first week of classes. Details will be sent to registrants by email.
- Footnote #43 Class meets at Eagle Ridge Golf Course.
- Footnote #44 Equipment will be provided. A \$6.00 user fee will be charged, payable to the instructor.
- Footnote #45 Meets at Hazel Hawkins Hospital, 911 Sunset Drive, Hollister.
- Footnote #46 \*\*\*\*\*
- Footnote #47 Meets at San Benito High School, 1220 Monterey Street, Hollister.
- Footnote #48 This class is part of a learning community. You are encouraged to enroll in a complementary course with linked curriculum.
- Footnote #49 A facility use fee will be charged. Details at first meeting.
- Footnote #50 Students taking this class will need to complete 10 hours of mentoring.
- Footnote #51 Meets at HOPE Workshop, 2300 Technology Parkway, Hollister.
- Footnote #52 Class meets at 7:30 a.m. in PH101 for first class session.
- Footnote #53 Class will meet on Saturday, Feb. 3, 2007 from 12-2 pm in PH 103 plus three additional meetings - dates to be announced.
- Footnote #54 This hybrid lecture/online class will be delivered partially over the internet. See the online syllabus for details. <http://www.gavilan.edu/disted/>. Mandatory open lab will be held on Saturday mornings.
- Footnote #55 \$150.00 course materials fee, payable at registration.
- Footnote #56 Meets at Britton School, 80 W. Central Avenue, Morgan Hill.
- Footnote #57 \$12 course material fee.
- Footnote #58 This CD class meets 6 Saturdays, Feb 24, March 3, 10, 17, 24 and 31, 2007 from 8:00 am - 4:00 pm at the Morgan Hill Community Center.
- Footnote #59 Meets at Employment Training Center, (formerly Weibe Manufacturing Bldg.), 1131 San Felipe Rd., Hollister.
- Footnote #60 Course delivery is through Gavilan Channel 18, Morgan Hill MHAT Channel 18 or video tape (\$25 refundable security deposit required payable to the instructor + \$22 materials fee payable at registration.) This telecourse will have three required on-campus meetings: Thursdays, Feb. 1, March 22 and May 24, 2007. Orientation for the course will be provided at the first class meeting. (HUM 4)
- Footnote #61 This CD class is taught on specific Saturdays at the Morgan Hill Community Center. The dates are Feb. 10, 24, March 10, 24, April 21, May 5 and 19.
- Footnote #62 Meets at Gilroy Bowl, 7554 Monterey Street, Gilroy. A facility use fee of \$1.50 per session required.
- Footnote #63 Meets at HOPE Workshop, 8855 Murray Avenue, Gilroy.
- Footnote #64 Meets at Gilroy High School, 750 West Tenth Street, Gilroy.
- Footnote #65 This class is part of the High Step program. It will be offered at Gilroy High School, room H-3. This class is open to all students. For more information, see a Gavilan counselor.
- Footnote #66 Dates to be announced, see instructor.
- Footnote #67 This class meets in the choir room of Gilroy High School.
- Footnote #68 Meets at Hollister Community Center, 300 West Street, Hollister.
- Footnote #69 This class is part of the High Step program. It will be offered at Live Oak High School. Check online footnote for location. This class is open to all students. For more information, see a Gavilan counselor.
- Footnote #70 Meets at Live Oak Adult Day Care, 651 West Sixth Street, Gilroy.
- Footnote #71 This section of CD 190 is for students working as tutors in elementary school settings.
- Footnote #72 AJ class not recommended for high school students.
- Footnote #73 This class requires a co-requisite of First Year Experience GUID 1 and English 250.
- Footnote #74 May be repeated based on measurable progress as documented in the Student's IEP Plan. (DRC)
- Footnote #75 Special registration procedures.
- Footnote #76 Please contact the Allied Health Department at (408) 848-4883 for more information.
- Footnote #77 Course will include the viewing of a cadaver.
- Footnote #78 This class requires a co-requisite of First Year Experience GUID 1 and English 260.
- Footnote #79 This class involves both lecture and hands-on computer assisted software. A lab fee of \$60.00 must be paid to the instructor during the first class meeting. Materials included in the lab fee take the place of a textbook. MATH 404, A-C is the equivalent of MATH 400. MATH 404, D-F is the equivalent of MATH 402.
- Footnote #80 Recommended for students participating in the EOP&S program.
- Footnote #81 Recommended for students participating in TRIO program.
- Footnote #82 This class is part of a Puente learning community. You must enroll in ALL courses.
- Footnote #83 Recommended for students participating in CalWORKs Program.
- Footnote #84 This class is part of the High Step program. It will be offered at Gilroy High School, room B-3. This class is open to all students. For more information, see a Gavilan counselor.
- Footnote #85 This class requires a co-requisite of First Year Experience English 250 and English 260.
- Footnote #86 This class is part of the High Step program. It will be offered at Gilroy High School, room BE. This class is open to all students. For more information, see a Gavilan counselor.
- Footnote #87 Students should check in the first week of the semester during lab hours. Visit the Fitness Center (GYM 123)
- Footnote #88 This class is designed for students participating in the CalWORKs program.
- Footnote #89 \$12.00 fee will be charged for career assessment materials.
- Footnote #90 Recommended for students with verified physical limitations.
- Footnote #91 \$25 refundable security deposit required for video rental. More details at first class meeting.
- Footnote #92 Health and fingerprint clearance required prior to clinical placement. Uniform, shoes, watch, and stethoscope required.
- Footnote #93 \$100.00 course materials fee, payable at registration.
- Footnote #94 Clinical in Morgan Hill or Hollister, as assigned.
- Footnote #95 \$20 materials fee. Payable at registration.
- Footnote #96 ROP class. Either college credit or ROP certificate.
- Footnote #97 Mandatory Puente orientation will be conducted on Wednesday, August 30, 2006, from 9 am - 1 pm in CH102. (Fall only)
- Footnote #98 \$5 course materials fee. Details at first class meeting.
- Footnote #99 Computer lab work can be done both in lab and off-site

\*\*\*\*\* indicates this footnote number not being used this term.

# SUMMER SESSION 2007 CLASS PREVIEW

## June 18 - July 27, 2007

Summer Session calendar dates subject to change. Check the Summer Calendar in the Gavilan College Summer/Fall 2007 Schedule of Classes.

*Look for the*

### Summer Session Registration Schedule

IN THE GAVILAN COLLEGE SUMMER/FALL SCHEDULE OF CLASSES. Look for it in your mailbox and online at [www.gavilan.edu](http://www.gavilan.edu) in early MAY

#### ADMINISTRATION OF JUSTICE

AJ 10 Introduction to the Administration of Justice

#### ALLIED HEALTH

AH 3 The Person in the Life Cycle  
AH 11 Nutrition  
AH 32 Basic Cardiac Life Support

#### ANTHROPOLOGY

ANTH 1 Introduction to Physical Anthropology  
ANTH 3 Introduction to Cultural Anthropology

#### ART

ART 1B Art History  
ART 6 Art Appreciation  
ART 10A Cultural History of Ceramics  
ART 10B Ceramics  
ART 23 Independent Study  
ART 25A Art Methods  
ART 25B Art Methods  
ART 98 Special Topics  
ART 108 Digital Media Lab

#### AVIATION MAINTENANCE TECHNOLOGY

AMT 123 Independent Study

#### BIOLOGICAL SCIENCE

BIO 10 Principles of Biology  
BIO 11 Nutrition  
BIO 15 Survey of Human Anatomy and Physiology

#### CHEMISTRY

CHEM 30A Elementary Chemistry

#### CHILD DEVELOPMENT

CD 2 Early Child Development  
CD 3 Child Growth and Development During the School Years  
CD 16 Exploring Mathematics with Children  
CD 17 Exploring Science with Children  
CD 20 Children's Language and Literature  
CD 25A Art Methods  
CD 25B Art Methods  
CD 28A Child Dev & Guidance for Family Child Care/Foster Care  
CD 28B Dev Learning Activities for Family Child Care & Foster Care  
CD 160 Child Care First Aid and CPR

#### COMMUNICATIONS

CMUN 1A Introduction to Public Speaking  
CMUN 10 Small Group Communication  
CMUN 129 Presentation Graphics - MS Powerpoint

#### COMPUTER SCIENCE & INFORMATION SYSTEMS

CSIS 1 Computer Literacy - MS Office  
CSIS 6 Web Page Authoring I  
CSIS 7 Web Page Authoring II  
CSIS 8 Introduction to the Internet  
CSIS 10 BASIC Programming  
CSIS 45 C++ Programming I  
CSIS 108 Digital Media Lab  
CSIS 122 Computer Keyboarding  
CSIS 124 Windows Fundamentals  
CSIS 126 Word Processing - MS Word  
CSIS 129 Presentation Graphics - MS PowerPoint  
CSIS 134 Intermediate Excel  
CSIS 570 Computer Access Evaluation  
CSIS 571 Computer Assisted Instruction

**COSMETOLOGY**

COS 207	Contemporary Styling
COS 223	Independent Study

**DIGITAL MEDIA**

DM 6	Web Page Authoring I
DM 7	Web Page Authoring II
DM 108	Digital Media Lab

**ENGLISH**

ENGL 1A	Composition
ENGL 1B	Composition and Literature
ENGL 1C	Critical Reasoning and Writing
ENGL 250	Practical Writing
ENGL 260	Preparation for College Reading
ENGL 420	Reading Improvement
ENGL 440	Basic Writing

**ENGLISH AS A SECOND LANGUAGE**

ESL 501A	Survival ESL I First Half
ESL 501B	Survival ESL I Second Half
ESL 502B	Survival ESL II Second Half
ESL 546	Introduction to Computers for ESL Students
ESL 581	ESL Pronunciation I
ESL 582	ESL Pronunciation II
ESL 584	Culture Through Film

**GEOLOGY**

GEOL 1	Introduction to Geology
--------	-------------------------

**GUIDANCE**

GUID 1	Self-Assessment and Career Development
GUID 22	Field Work and Service
GUID 250	Supervised Tutoring
GUID 557	Learning Skills Assessment
GUID 558	Learning Skills Laboratory

**HEALTH EDUCATION**

HE 1	Health Education
------	------------------

**HISTORY**

HIST 1	United States History through Reconstruction
HIST 2	United States History Reconstruction to the Present

**LIBRARY**

LIB 6	Web Page Authoring I
-------	----------------------



**ESL 584 Culture through Film**

Learn more about American culture and improve your listening/speaking skills while watching movies in this new intermediate/advanced ESL class!



Do you want to speak more clearly and be better understood? Then check out our two new ESL PRONUNCIATION courses!



**ESL 581/582**

**ESL PRONUNCIATION I & II**

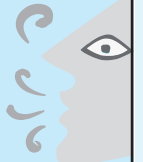

**REGISTER TODAY!**

By Phone (408) 612-2056  
 Online [www.gavilan.edu/star](http://www.gavilan.edu/star)  
 Email [stargav@gavilan.edu](mailto:stargav@gavilan.edu)



**SPRING STAR**

March 3, 10, 17, 24, 31 2007  
 5 Saturdays- \$100  
 Ages 9-16  
 9:00 am - 12:00 pm

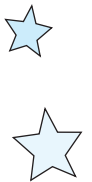

**STAR GILROY**

JUNE 25-JULY 21 2007  
 4 Weeks - \$525  
 Performances on July 20 & 21  
 Ages 7-16  
 9:00 am - 4:00 pm



**STAR SAN JUAN BAUTISTA**

JULY 24-AUG. 11- 2007  
 3 weeks - \$395  
 Ages 10-16  
 9:00 am - 4:00 pm, M-F



**STAR VIDEO**

JUNE 25-JULY 13 2007  
 3 Weeks- \$395  
 Ages 12-16  
 9:00 am - 4:00 pm, M-F



**MATHEMATICS**

MATH 5	Introduction to Statistics
MATH 8A	First Half of Precalculus
MATH 205	Elementary Algebra
MATH 208	Plane Geometry
MATH 233	Intermediate Algebra
MATH 402	Pre-Algebra
MATH 414	Basic Math Skills

**PHILOSOPHY**

PHIL 2	Logic
--------	-------

**PHYSICAL EDUCATION: ACTIVITIES**

PE 16	Swimming
PE 17	Golf
PE 21	Volleyball
PE 24	Individualized Weight Training
PE 27	Basketball
PE 37	Softball
PE 46	Agility and Motor Development
PE 61	Swim for Fitness
PE 62	Yoga
PE 64	Individualized Cardiovascular Fitness
PE 65	Baseball
PE 66	Dance Fundamentals
PE 70	Pilates
PE 73	Fitness through Dance

**PHYSICAL EDUCATION: ADAPTED**

PE 34	Adapted Aquatic Exercise
PE 35	Adapted Swimming for Total Fitness
PE 36	Adapted Physical Education
PE 38	Adapted Cardiovascular Conditioning & Training
PE 534	Adapted Aquatic Exercise
PE 535	Adapted Swimming for Total Fitness
PE 536	Adapted Physical Education
PE 538	Adapted Cardiovascular Conditioning & Training

**PHYSICAL SCIENCE**

PSCI 1	Principles of Physical Science
--------	--------------------------------

**POLITICAL SCIENCE**

POLS 1	Introduction to American Government
--------	-------------------------------------

**PSYCHOLOGY**

PSYC 1A	Introduction to Psychology
PSYC 2	Early Child Development
PSYC 3	Child Growth and Development During the School Years
PSYC 5	Self-Assessment and Career Development

**REAL ESTATE**

RE 165	Legal Aspects of Real Estate
--------	------------------------------

**SOCIOLOGY**

SOC 1A	Introduction to Sociology
SOC 3	Sociology of Minorities

**SPANISH**

SPAN 1A	Elementary Spanish
SPAN 1B	Elementary Spanish
SPAN 2A	Intermediate Spanish
SPAN 2B	Intermediate Spanish
SPAN 8A	Conversational Spanish
SPAN 8B	Conversational Spanish
SPAN 8C	Conversational Spanish
SPAN 8D	Conversational Spanish
SPAN 23	Independent Study
SPAN 98	Special Topics

**THEATRE ARTS / DRAMA**

THEA 1	Theatre History
THEA 23	Independent Study

**VOCATIONAL PREPARATION FOR DISABLED**

AE 600	Vocational Training I
AE 602	Vocational Training III
AE 636	Adapted Physical Education

**Summer Online Classes**

For more information call (408) 848-4885.

AH 11	NUTRITION
ANTH 1	INTRO PHYSICAL ANTH
ART 6	ART APPRECIATION
BIO 11	NUTRITION
CD 2	EARLY CHILD DEVELOP
CD 3	CHILD GROWTH/DEV
CD 19	INTRO CAREERS/CHLDN
CSIS 8	INTRO TO INTERNET
CSIS 10	BASIC PROGRAMMING
CSIS 45	C++ PROGRAMMING I
ENGL 1A	COMPOSITION
ENGL 1B	COMPOSITION & LIT
ENGL 1C	CRITIC REASON/WRITE
GUID 1	SELF ASSESSMENT
HE 1	HEALTH EDUCATION
LIB 732	INTRO TO ONLINE GAVILAN
POLS 1	INTRO AMERICAN GOVERNMENT
PSYC 2	EARLY CHILD DEVELOP
PSYC 3	CHILD GROWTH/DEV
PSYC 5	SELF ASSESSMENT
THEA 1	THEATRE HISTORY

# QUICK REFERENCE

Gavilan College offers courses that meet in Morgan Hill and Hollister, on the weekend and start late in the term.

## Morgan Hill Courses

Morgan Hill Community and Cultural Center  
17060 Monterey Rd.  
Morgan Hill, CA 95037  
(408) 782-2873

CD 20	CHILDREN'S LAN/LIT
CD 28B	DEV LEARNING ACTIVI
CD 28C	ADMIN CHLD CARE HOM
CD 28C	ADMIN CHLD CARE HOM
CSIS 6	WEBPAGE AUTHORIZING I
CSIS 7	WEB PAGE AUTHOR II
CSIS 10	BASIC PROGRAMMING
CSIS 134	INTERMEDIATE EXCEL
DM 6	WEBPAGE AUTHORIZING I
DM 7	WEB PAGE AUTHOR II
LIB 6	WEBPAGE AUTHORIZING I
MATH 5	INTRO STATISTICS
MATH 233	INTERMED ALGEBRA
PSYC 1A	INTRO TO PSYCHOLOGY
SOC 1A	INTRO TO SOCIOLOGY

## Hollister Courses (San Benito County)

Briggs Building  
365 Fourth St.  
Hollister, CA 95023  
(831) 636-3783

AH 740	TAI CHI ARTHRITIS
AMT 123	INDEPENDENT STUDY
AMT 123	INDEPENDENT STUDY
CMUN 1A	INTRO PUBLIC SPEAK
CSIS 1	COMPUTER LITERACY
ENGL 1A	COMPOSITION
ENGL 250	PRACTICAL WRITING
ESL 501A	SURVIVAL ESL I A
LIB 730	INTERNET LITERACY
MATH 205	ELEM ALGEBRA
MATH 233	INTERMED ALGEBRA

## Campus under construction ROOM NUMBERS MAY CHANGE!

Check room number online before your first class.



Providing lifelong learning opportunities to people of all ages!

- Short-term
- Not-for-credit

Have fun with Ballroom Dancing. Learn quick tips in Word, Excel, QuickBooks. Explore your creativity in Drawing and Painting.

**Want to make money?** For more information or to teach for us, go to our website at [www.gavilan.edu/ce](http://www.gavilan.edu/ce) and click on Community Education or call us at (408) 847-2514, ext. 1.

### Need training for your employees?

Want to provide Professional Development opportunities for your staff and managers?

**Contract Education** can help! Whether you are looking for ESL or Supervision, Workplace Spanish or Leadership Skills, we can help. Call us at (408) 847-2514, ext. 3.

## Study and travel this summer! Learn Spanish in Spain!



June 3-30

Earn up to 5 units

Study the language and culture while living with a host family in Seville, Spain

Cost: Approximately \$1,500 plus airfare for a 4-week program.

Attend the Orientation:  
Saturday, Feb 24 at 9:30 am in HU105 on the Gilroy main campus

For more information, visit the website at [www.gavilan.edu/spanish](http://www.gavilan.edu/spanish) or call Albert Marques at (408) 848-4794 or email [amarques@gavilan.edu](mailto:amarques@gavilan.edu)



## What is the Transfer Institute?

The Transfer Institute (TI) is a Gavilan College program that guides you through the transfer process in the most efficient and effective means possible. As a part of the Transfer Institute you will save time and money by completing your freshman and sophomore years at Gavilan. You will also meet and get to know other students who share your goals and ambition.

## Who is eligible?

- Recent high school graduates who are academically prepared for college level work.
- Students with placement in *college level English & math*.

## How do I apply for the Transfer Institute?

- Complete a Transfer Institute application in April prior to high school graduation.
- Take a Gavilan College placement test.
- Complete a Gavilan College admissions application and
- Submit a High School transcript.

*Limited spaces are available - apply early!*

## Transfer Institute Services:

Your success is dependent on your attendance in enrolled classes, completion of course assignments and participation in Transfer Institute support services.

The following are some of the many Transfer Institute services available that will ensure your academic and transfer success:

- Early connections with university admission representatives.
- Assistance with completing your transfer applications.
- Development of your personal TI agreement that identifies academic services, support services and activities essential to your transfer planning and success.
- Development of an individual Educational Plan by trained and knowledgeable counseling faculty that charts courses needed for completion of general education and major preparation.
- Documented evaluation of courses completed at other colleges that transfer to and satisfy university requirements.
- Semester-by-semester feedback on transfer progress.
- Transfer information updates and event announcements to keep you connected with and prepared for the university experience.
- Assistance with finding sources of financial aid and educational financial planning.
- Opportunities to participate in university field trips.
- Workshops to assist with the transfer process.
- Eligibility assistance with all participating TAA's (Transfer Admissions Agreements.)

## Transfer Institute Benefits:

Transfer Institute students receive:

- Early Registration.
- A dedicated counselor to guide and monitor you through the transfer process.
- Pre-transfer events and activities with four-year universities.
- Access to activities designed to ensure your success at Gavilan College.
- Assistance with the identification of and preparation for a college major.
- A two-year agreement guaranteeing your transfer goals.

**Applications for the fall 2007 Transfer Institute will be accepted beginning in April 2007.**

For more information, call (408) 848-4723 or visit the website at [www.gavilan.edu/transfer](http://www.gavilan.edu/transfer)

Transfer Institute application: see following page.

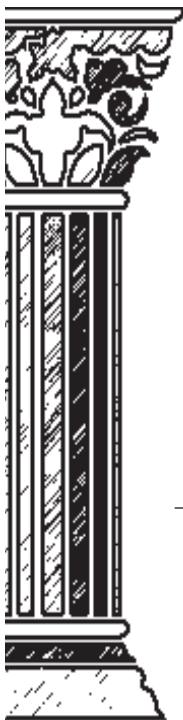



### APPLICATION - Spring 2007

Name: \_\_\_\_\_ Social Security #: \_\_\_\_\_ - \_\_\_\_\_ - \_\_\_\_\_  
 Address: \_\_\_\_\_ Phone: (\_\_\_\_\_) \_\_\_\_\_ - \_\_\_\_\_  
 City: \_\_\_\_\_ Cell Phone: \_\_\_\_\_  
 Zip Code: \_\_\_\_\_ Email: \_\_\_\_\_

I would like to transfer to: \_\_\_\_\_ California State University \_\_\_\_\_ University of California  
 \_\_\_\_\_ Private College/University \_\_\_\_\_ Not sure which system

Are you working while attending college? \_\_\_\_\_ Yes (# of hours per week \_\_\_\_\_) \_\_\_\_\_ No

Are you eligible for financial aid? \_\_\_\_\_ Yes \_\_\_\_\_ No \_\_\_\_\_ Don't Know

High School Graduate? \_\_\_\_\_ Yes \_\_\_\_\_ No \_\_\_\_\_ GED Year Graduated: \_\_\_\_\_

Name of High School: \_\_\_\_\_ City: \_\_\_\_\_ State: \_\_\_\_\_

Major: \_\_\_\_\_ Currently Undecided: \_\_\_\_\_

Please describe your career goal: \_\_\_\_\_  
 \_\_\_\_\_

Please describe why you want to be in the Transfer Institute: \_\_\_\_\_  
 \_\_\_\_\_

For office use only	College Level: English 1A and Transfer Level Math:
Placement/Assessment Scores:	_____ Reading _____ Writing _____ Math

**Intent to Register:**

I agree to make a full commitment to the Transfer Institute. This commitment includes the following:

- Complete 30 transferable units in an Academic Year
- Work with a counselor on a regular basis.
- Participate in Transfer Institute activities
- Sign a Transfer Institute agreement.

**Student Signature:** \_\_\_\_\_ **Date:** \_\_\_\_\_

**IMPORTANT, PLEASE RETURN TO:**



**Gavilan College Counseling Department**  
**5055 Santa Teresa Blvd.**  
**Gilroy, CA 95020**

**COMMUNITY-BASED ART**

**Art 14: Introduction to Murals**  
 Sect. 4097, 3 units  
 Wednesday, 3:15 pm - 7:20 pm  
 Instructor: r2row  
 Satisfies CSU General Education Area c-1

**MAKING A DIFFERENCE**

for more info:  
[art4service.org](http://art4service.org)

**NO ART EXPERIENCE NEEDED**

Join us!

**FREE!!**

Monday evenings for the

# Monday Night Series

6:30 p.m.

Gavilan College Theater

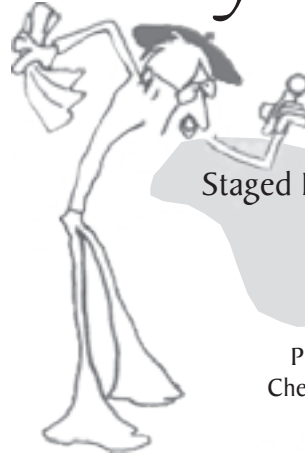

Staged Readings of Scripts, Plays and Literature!

Presented by Gavilan Theatre Arts  
 Check the Theater Department Website for play titles and dates.

**GAVFEST 2007**  
 SPRING FESTIVAL  
 AND OPEN HOUSE

APRIL 21, 2007  
 10 A.M. - 3 P.M.  
**ADMISSION IS FREE!**

MUSIC, FOOD, ART, CRAFTS,  
 SPORTS, "GAVILAND" KIDS AREA, SOCCER  
 TOURNAMENT, BATTLE OF THE BANDS,  
 BOAT RACES AND LOTS MORE!

**Science Alive!**  
 Conference

February 10, 2007

Hands-on Math, Science and Computer  
 Workshops for Kids (grades 5-8)  
 Education and Financial Aid  
 Workshops for Parents

[www.gavilan.edu/sciencealive](http://www.gavilan.edu/sciencealive)



# MAIN CAMPUS, GILROY

5055 Santa Teresa Blvd.  
 Gilroy, CA 95020  
 408-848-4800 or  
 831-637-1158 (from Hollister)



## Key to Gavilan College

Administration	SC
Admissions & Records	SC
Art Gallery	LI
Art Lecture	AL
ASB	SC
Assessment Center	LS
Athletics Office	GY/AP
Bookstore	SC
Business Office	BOB
Cafeteria	SC
CalWORKs	LI
Career/Transfer Center	SC
Cashier	BOB
Child Development Center	CD
Children's Preschool	CD
CMAP	LI
Community Ed	CJ
Computer Graphics & Design	LI
Counseling Offices	SC
Disability Resource Center	LI
English/ESL	HU
EOPS/Special Services	LI
Financial Aid Office	SC
Information/Switchboard	SC
Lounges, North and South	SC
Math Lab	PH
MESA	PH
Music	TH
Noncredit Program	LS
Nursing	HOB
Payroll	BOB
Physical Education	GY/AP
Police Academy	PA
Public Information Office	TH
ROP	BU
Security	S/M
Student Health Nurse	SC
Student Senate Office	SC
TRIO Program	SC
Tutoring Center Services	LI
TV Studio	LI

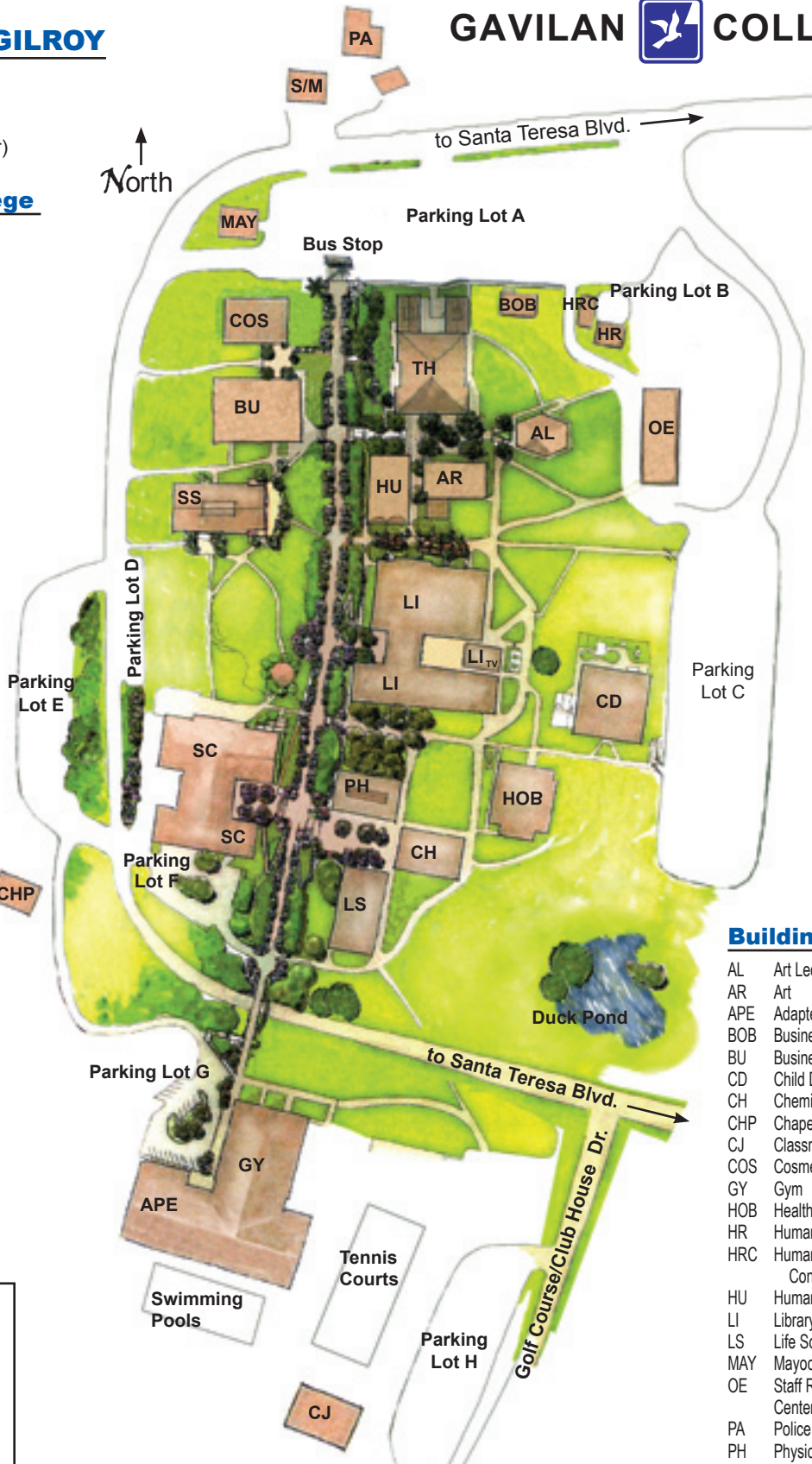

## Building Guide

AL	Art Lecture
AR	Art
APE	Adapted Physical Education
BOB	Business Office Building
BU	Business
CD	Child Development
CH	Chemistry
CHP	Chapel
CJ	Classrooms, Community Ed.
COS	Cosmetology
GY	Gym
HOB	Health Occupations Bldg.
HR	Human Resources
HRC	Human Resources Conference Center
HU	Humanities
LI	Library
LS	Life Science
MAY	Mayock House
OE	Staff Resource Center/Classrooms
PA	Police Academy
PH	Physical Science
SC	Student Center
S/M	Security/Maintenance
SS	Social Science
TH	Theater

## Parking Lots

A	Student / Staff / Disabled Access
B	Staff / Disabled Access / Visitor
C	Student / Staff / Disabled Access
D	Staff / Disabled Access
E	Student / Staff / Motorcycle
F	Staff / Disabled Access / Visitor / Motorcycle
G	Staff / Disabled Access
H	Student / Staff / Disabled Access

**DONT GO TO THE WRONG CITY!**

**MHG = Morgan Hill**

**HOL = Hollister**