

CRN Type Room Instructor Hrs. Units Days Begin-End

ECON 2 Principles of Microeconomics

Transferable: CSU, UC; CSU-GE:D2, IGETC:4B; GAV-GE:D2; CAN:ECON4

Introduction to microeconomic principles and theory; supply, demand; product and factor price determination, resource allocation, costs, revenues, and profits under different competitive situations; international trade; government regulation and taxation. Note: Economics 1 is not a prerequisite for Economics 2. This course has the option of a letter grade or pass/no pass. **ADVISORY:** Eligible for English 260, English 250 and Mathematics 233.

10946	Lec	PB5	Truongson B	3.6	3.0	TR	1250-0220
10891	Lec	HU102	Shokou A	3.3	3.0	T	0600-0905

Education: see Child Development

ENGLISH

ENGL 1A Composition

Transferable: CSU, UC; CSU-GE:A2, IGETC:1A; GAV-GE:A2; CAN:ENGL2, ENGL SEQ A

This is a writing course which emphasizes expository writing, argumentative writing, and critical reading of expository prose. It is meant to train students in clear thinking and reasoned support of ideas. Students will be given the opportunity to read models of good expository and argumentative prose and learn the techniques of good writing. These include choosing appropriate subjects, developing restricted, unified, and precise theses and presenting supporting evidence in a logical, lucid, and effective manner. To achieve this end, students write no fewer than six essays and read at least five works, two of which are book length. **PREREQUISITE:** English 250 and English 260 or English 250 and SSCI 270A or English 250 and SSCI 270B with a grade of 'C' or better or satisfactory score on the English placement examination.

10107	Lec	HU103	Pirani A	3.2	3.0	MW	0810-0930	
10108	Lec	MHG3	Bragger M	3.2	3.0	MW	0810-0930 Above class meets at Morgan Hill Community site.	
10111	Lec	SS203	Allison M	3.3	3.0	F	0900-1205	
10124	Lec	HOL5	Mora G	3.3	3.0	F	0900-1205 Above class meets at the Hollister Briggs site.	
10110	Lec	SS203	Condon D	3.2	3.0	TR	0945-1105	
10109	Lec	PH102	Mora G	3.2	3.0	MW	1120-1240	
12	10112	Lec	HOL5	Salvin C	3.2	3.0	TR	1120-1240 Above class meets at the Hollister Briggs site.
10113	Lec	SS111	Osikomaiya J	3.2	3.0	MW	1250-0210	
13	10114	Lec	SS111	Hirasuna S	3.2	3.0	TR	1250-0210
10115	Lec	HU103	Osikomaiya J	3.2	3.0	MW	0230-0350	
10116	Lec	HU103	Allison M	3.2	3.0	TR	0400-0520	
5	10120	Lec	HOL1	Brett T	3.3	3.0	W	0600-0905 Above class meets at the Hollister Briggs site.
10122	Lec	HU103	Pirani A	3.3	3.0	R	0600-0905	
10119	Lec	MHG11	Kovacs M	3.3	3.0	M	0630-0935 Above class meets at Morgan Hill Community site.	
10123	Lec	HU102	Jahan H	3.3	3.0	M	0600-0905	

2 10117 ONLINE Luoma D 3.0
You must have an email account to take this course. Start your course by going to www.gavilan.edu/disted. Unless you have made prior arrangements with the instructor, you MUST log on by 11:59 pm on the first day of the semester. Late adds must login within 24 hours of adding this course. If you miss the deadline you may be dropped. For help, contact your instructor or email disted@gavilan.edu.

10118 ONLINE Chaffin C 3.0
You must have an email account to take this course. Start your course by going to www.gavilan.edu/disted. Unless you have made prior arrangements with the instructor, you MUST log on by 11:59 pm on the first day of the semester. Late adds must login within 24 hours of adding this course. If you miss the deadline you may be dropped. For help, contact your instructor or email disted@gavilan.edu.

10121 ONLINE Crook E 3.0
You must have an email account to take this course. Start your course by going to www.gavilan.edu/disted. Unless you have made prior arrangements with the instructor, you MUST log on by 11:59 pm on the first day of the semester. Late adds must login within 24 hours of adding this course. If you miss the deadline you may be dropped. For help, contact your instructor or email disted@gavilan.edu.

Choose a **THEME** for your English class:

Find the number, by the course section number, that corresponds to a theme below.

- 1 Explore American consumerism and wild alternatives.
- 2 Explore the great American classics.
- 3 Explore diversity, equality, and tolerance in the Freedom Writer's Diary and American life today.
- 4 Explore the great literature of the human condition, challenging you to respond to literary art, science fiction, music, tragedy and the joy of life and living.
- 5 Explore the exciting realm of science and discover who we are, how we got here, and learn about the scientists and explorers who got us here while learning to write with panache, flair and accuracy.
- 6 Learn to think, to think courageously, to think intelligently and to think for yourself through challenging the pseudoscientific, the paranormal, the make-believe world of nutty beliefs and scams.
- 7 First Year Experience: Use what we discover through our brains, bodies and spirits to create, in a classroom where we practice thinking like scientists, literary critics and artists.
- 8 Take a different look at the wars we all think we know, through the literature and personal accounts of writers such as John Steinbeck, Eve Ensler and Lousi DeBernais.
- 9 Learning Community: Explore the theme of Nurturing Childhood in a dynamic, supportive learning environment using writing, discussion, and discovery to identify nurturance as an important part of family life and community action.
- 10 First Year Experience: Explore the issues of Peace and Conflict through reading and writing.
- 11 Puente: Develop writing skills through an emphasis on Chicano/Latino literature.
- 12 Investigate environmental issues, particularly those connected to what we eat and where we live.
- 13 Develop expository writing skills in response to literary works from a rich diversity of American cultures.
- 14 Read and write in a class of Fantasy and Folklore.



The Puente Project is a two-semester program that combines three components: writing, counseling and mentoring to support students to transfer to four-year universities and colleges. The Guidance 1 course focuses on self assessment and career development. The English 250 course focuses on Mexican American/Latino literature. The program also includes a student leadership conference, university visits and mentor/student socials. The program is open to all eligible students. For more information, call Celia Marquez, Puente Co-Coordinator at 408-848-4807.

Required: Complete a program application with the Puente Counselor prior to registration. Students must attend a mandatory Puente Welcome on Wednesday, August 26, from 8:30 am - 1 pm in SS206.

GUID 1 CRN 10819 LS106 Marquez C MW 1120A-1240P
Students will need to complete 10 hours of mentoring.

Choose one of the ENGL 250 courses listed below:

ENGL 250	CRN 10158	PH102 LI120	Sandler S Sandler S	TuTh T	1120A -1240P 1255P - 0145P
ENGL 250	CRN 10159	PH102 LI120	Sandler S Sandler S	TR R	1120A - 1240P 1255P - 0145P

CRN Type Room Instructor Hrs. Units Days Begin-End

ENGL 1B Composition and Literature

Transferable: CSU, UC; CSU-GE:C, IGETC:3B; GAV-GE:C2; CAN:ENGL4, ENGL SEQ A

English 1B continues the work begun in 1A, but now the emphasis shifts to writing expository prose in conjunction with reading and analyzing imaginative literature. Students are to write as fledgling critics and use the text as a basis for other forms of reflection. The reading requirement includes short stories, poetry, drama, and at least two novels. Course work will also include fundamentals of research writing. PREREQUISITE: English 1A with a grade of "C" or better.

10128	Lec	HU103	Jahan H	3.3	3.0	F	0900-1205
10127	Lec	HU103	Crook E	3.2	3.0	TR	0945-1105
10129	Lec	SS111	Richards G	3.2	3.0	TR	1120-1240
10130	Lec	SS203	Oral M	3.2	3.0	MW	1250-0210
10131	Lec	HU102	Jahan H	3.2	3.0	MW	0230-0350
10133	Lec	HOL4	Mora G	3.2	3.0	MW	0400-0520 Above class meets at the Hollister Briggs site.
10132	Lec	HU102	Brett T	3.3	3.0	R	0600-0905
10125	ONLINE		Raimondo J	3.0			You must have an email account to take this course. Start your course by going to www.gavilan.edu/disted . Unless you have made prior arrangements with the instructor, you MUST log on by 11:59 pm on the first day of the semester. Late adds must login within 24 hours of adding this course. If you miss the deadline you may be dropped. For help, contact your instructor or email disted@gavilan.edu .
10126	ONLINE		Warren K	3.0			You must have an email account to take this course. Start your course by going to www.gavilan.edu/disted . Unless you have made prior arrangements with the instructor, you MUST log on by 11:59 pm on the first day of the semester. Late adds must login within 24 hours of adding this course. If you miss the deadline you may be dropped. For help, contact your instructor or email disted@gavilan.edu .
10134	ONLINE		Raimondo J	3.0			You must have an email account to take this course. Start your course by going to www.gavilan.edu/disted . Unless you have made prior arrangements with the instructor, you MUST log on by 11:59 pm on the first day of the semester. Late adds must login within 24 hours of adding this course. If you miss the deadline you may be dropped. For help, contact your instructor or email disted@gavilan.edu .

Be Aware

You MAY NOT take courses that overlap (courses that meet at the same day and time)!

CRN Type Room Instructor Hrs. Units Days Begin-End

ENGL 1C Critical Reasoning and Writing

Transferable: CSU, UC; CSU-GE:A3, IGETC:1B; GAV-GE:C2

This course is designed to develop critical thinking, reading, and writing skills beyond the level achieved in English 1A. The emphasis is on critical analysis of arguments and the development of the ability to integrate the principles of critical thinking into essay writing. PREREQUISITE: English 1A with a grade of "C" or better.

10136	Lec	SS203	Condon D	3.2	3.0	TR	0810-0930
10137	Lec	MHG11	Luoma D	3.2	3.0	MW	1120-1240 Above class meets at Morgan Hill Community site.
10138	Lec	HU102	Luoma D	3.2	3.0	TR	0400-0520
10139	Lec	SS203	Brett T	3.3	3.0	M	0600-0905
10135	ONLINE		Chaffin C	3.0			You must have an email account to take this course. Start your course by going to www.gavilan.edu/disted . Unless you have made prior arrangements with the instructor, you MUST log on by 11:59 pm on the first day of the semester. Late adds must login within 24 hours of adding this course. If you miss the deadline you may be dropped. For help, contact your instructor or email disted@gavilan.edu .
10140	ONLINE		Allison M	3.0			You must have an email account to take this course. Start your course by going to www.gavilan.edu/disted . Unless you have made prior arrangements with the instructor, you MUST log on by 11:59 pm on the first day of the semester. Late adds must login within 24 hours of adding this course. If you miss the deadline you may be dropped. For help, contact your instructor or email disted@gavilan.edu .

ENGL 2C Introduction to Film and Fiction

Transferable: CSU, UC; CSU-GE:C2, IGETC:3B; GAV-GE:C2

This is a literature course in analysis of the novel and film as art forms. The student will read several novels, view the films based on the novels, and discuss the difference in techniques, both orally and in writing. PREREQUISITE: Eligible for English 1A.

10197	Lec	SS214	Richards G	3.3	3.0	W	0630-0935
-------	-----	-------	------------	-----	-----	---	-----------

ENGL 2E Introduction to Women Writers

Transferable: CSU, UC; CSU-GE:C2, IGETC:3B; GAV-GE:C2, F

This is a transfer literature class which examines the history of women as writers and distinguishes themes in women's literature using the tools of literary criticism. PREREQUISITE: Eligible for English 1A.

10240	Lec	SS111	Salvin C	3.2	3.0	MW	1120-1240
-------	-----	-------	----------	-----	-----	----	-----------

Have you met the prerequisite?
It's required!

English 9A, B, C

CREATIVE Writing



Instructor: Karen Warren received her BA & MA at San Francisco State University.

"I love watching my students get engaged as writers and thinkers," says Karen Warren. "I know how much many of them sacrifice to get an education, and I'm privileged to help make it possible." Ms. Warren has taught English at Gavilan College for the past thirteen years and previously at Cabrillo College and the University of California Santa Cruz. Since graduation from the Creative Writing program at San Francisco State University, Karen has written plays, poetry, fiction, and memoir. She also enjoys creating digital stories with photographs, video, and audio components.

This class fulfills your CSU humanities transfer requirement.



Instructor: Michael Kovacs received his B.A. in English from UC, Berkeley, and his M.A. in English with an emphasis in American literature from Stanford University.

Michael is from the Bay Area, and currently lives in San Jose, CA and New Mexico. He has published and presented papers on the Beat Generation writer Jack Kerouac and Fresno-based writer William Saroyan. Michael is currently writing a personal memoir.

CRN Type Room Instructor Hrs. Units Days Begin-End

ENGL 5A Survey of American Literature - 1620 to 1865

Transferable: CSU; UC; CSU-GE: C2; IGETC: 3B; GAV-GE: C2; CAN: ENGL 14, ENGL SEQ. C
This course is a study of the masters of American literature covering the years 1620 to 1865 A.D. **PREREQUISITE:** Eligible for English 1A.

10228 ONLINE Sandler S 3.0

You must have an email account to take this course. Start your course by going to www.gavilan.edu/disted. Unless you have made prior arrangements with the instructor, you **MUST** log on by 11:59 pm on the first day of the semester. Late adds must login within 24 hours of adding this course. If you miss the deadline you may be dropped. For help, contact your instructor or email disted@gavilan.edu.

ENGL 9A Introduction to Creative Writing

Transferable: CSU, UC; CSU-GE:C2; GAV-GE:C2; CAN:ENGL6

This course includes the writing, reading, and critical discussions of various forms of poetry and fiction. **PREREQUISITE:** Eligible for English 1A.

10229 Lec SS216 Warren K 3.2 3.0 TR 1120-1240

10230 Lec HU102 Kovacs M 3.3 3.0 W 0600-0905

ENGL 9B Advanced Creative Writing

Transferable: CSU, UC; CSU-GE:C2; GAV-GE:C2

This class is a continuation of English 9A, with the emphasis shifting to publication. The genre of non-fiction will be the primary focus, but the genres of fiction will also be taught at a more comprehensive level than in English 9A. The process of finding a market for one's work will be followed step by step. The class may compile and publish "Soaring", Gavilan's literary magazine, each spring semester. **PREREQUISITE:** English 9A with a grade of credit or C or better.

10231 Lec SS216 Warren K 3.2 3.0 TR 1120-1240

10232 Lec HU102 Kovacs M 3.3 3.0 W 0600-0905

ENGL 9C Poetry Writing

Transferable: CSU, UC; CSU-GE:C2; GAV-GE:C2

This course includes the writing, reading, and critical discussions of various forms of poetry. **PREREQUISITE:** English 9A with a grade of credit or C or better.

10233 Lec SS216 Warren K 3.2 3.0 TR 1120-1240

10234 Lec HU102 Kovacs M 3.3 3.0 W 0600-0905

ENGL 12A Tutoring Writers: Training/Theory & Practice

Transferable: CSU

Fundamentals of compositional theory, the writing process, peer-to-peer communication, interacting with faculty and educational institutions and effective responses to writing will be covered. In addition, students will gain an understanding of the basic history, methodology and practice of writing pedagogy while developing a writing community that aids in connecting them to their own writing practice. **ADVISORY:** Eligible for English 1A.

Required: Students enrolling in CRN below must attend an intensive week-long seminar the week prior to the start of fall semester:

08/24/09 - 08/27/09 LI120 Smith K MTWR 0930-0230

10098 Lec LI120 Smith K 2.3 3.0 M 0230-0435

ENGL 12B Tutoring Writers: Training/Theory & Practice

Transferable: CSU

Fundamentals of compositional theory, the writing process, peer-to-peer communication, interacting with faculty and educational institutions and effective responses to writing will be covered. In addition, students will gain an understanding of the basic history, methodology and practice of writing pedagogy while developing a writing community that aids in connecting them to their own writing practice. **ADVISORY:** Eligible for English 1A.

Required: Students enrolling in CRNs below must attend an intensive week-long seminar the week prior to the start of fall semester:

08/24/09 - 08/27/09 LI120 Smith K MTWR 0930-0230

10141 Lec LI120 Smith K 1.3 2.0 M 0230-0335

10100 Lec LI120 Smith K 2.3 3.0 M 0230-0435

Discover
women's
literature from
around the
globe!

CRN #10240
Monday/Wednesday
11:20 am - 12:40 pm
Instructor -Christina Salvin

ENGL 2E

Introduction to Women Writers



Satisfies the humanities requirement under the IGETC, the CSU-GE Breadth and the AA/AS Degree patterns.

Introduction to Film & Fiction ENGL 2C



CRN #10197
Wednesday
6:30 pm - 9:35 pm
Instructor - Grant Richards

*The DaVinci Code
Pride and Prejudice
Million Dollar Baby
Mystic River
A History of Violence
Cold Mountain
Sideways
Motorcycle Diaries
Closer
Fight Club
Notebook
High Fidelity
The Shawshank Redemption
To Kill a Mockingbird
One Flew Over the Cuckoo's Nest
Chocolat
LA Confidential
Get Shorty
and more!*

This class can fulfill your IGETC humanities transfer requirement.

ENGL 5A Survey of American Literature

CRN 10228
with Scott Sandler



Satisfies the humanities requirement under the IGETC, the CSU-GE Breadth and the AA/AS Degree patterns.

Offered 

CRN Type Room Instructor Hrs. Units Days Begin-End

ENGL 12C Tutoring Writers: Training/Theory & Practice

Transferable: CSU

Fundamentals of compositional theory, the writing process, peer-to-peer communication, interacting with faculty and educational institutions and effective responses to writing will be covered. In addition, students will gain an understanding of the basic history, methodology and practice of writing pedagogy while developing a writing community that aids in connecting them to their own writing practice. ADVISORY: Eligible for English 1A.

Required: Students enrolling in CRNs below must attend an intensive week-long seminar the week prior to the start of fall semester:

08/24/09 - 08/27/09	LI120	Smith K	MTWR	0930-0230
10102 Lec	LI120	Smith K	1.3 2.0 M	0230-0335
10103 Lec	LI120	Smith K	2.3 3.0 M	0230-0435

ENGL 12D Tutoring Writers: Training, Theory & Practice

Transferable: CSU

Fundamentals of compositional theory, the writing process, peer-to-peer communication, interacting with faculty and educational institutions and effective responses to writing will be covered. In addition, students will gain an understanding of the basic history, methodology and practice of writing pedagogy while developing a writing community that aids in connecting them to their own writing practice. ADVISORY: Eligible for English 1A.

Required: Students enrolling in CRNs below must attend an intensive week-long seminar the week prior to the start of fall semester:

08/24/09 - 08/27/09	LI120	Smith K	MTWR	0930-0230
10105 Lec	LI120	Smith K	1.3 2.0 M	0230-0335
10106 Lec	LI120	Smith K	2.3 3.0 M	0230-0435

ENGL 23 Independent Study

Transferable: CSU

Designed to afford selected students specialized opportunities for exploring areas at the independent study level. The courses may involve extensive library work, research in the community, or special projects. May be repeated until six units of credit are accrued. This course has the option of a letter grade or pass/no pass. REQUIRED: The study outline prepared by the student and the instructor must be filed with the department and the dean.

10142 IND	LI119	Smith K	1.0
10144 IND	SS109	Warren K	1.0
10143 IND	LI119	Smith K	2.0

CRN Type Room Instructor Hrs. Units Days Begin-End

ENGL 250 Practical Writing

Transferable: No; GAV-GE:A2

This course covers writing clear, correct, effective essays and learning preliminary research skills. PREREQUISITE: English 440 or ESL 563 with a grade of 'C' or better or satisfactory score on the English placement examination.

1 2 3 Your ENGL 250 class has a theme. See list on page 91.

10145 Lec	HU102	Oral M	3.2 3.0 MW	0810-0930
Lab	LI171	Oral M	1.0 M	0945-1035
10146 Lec	HU102	Oral M	3.2 3.0 MW	0810-0930
Lab	LI171	Oral M	1.0 W	0945-1035
10147 Lec	HU102	STAFF S	3.2 3.0 TR	0810-0930
Lab	LI171	STAFF S	1.0 F	0810-0900
10148 Lec	HU102	STAFF S	3.2 3.0 TR	0810-0930
Lab	LI171	STAFF S	1.0 F	0910-1000
10151 Lec	HU102	Salvin C	3.2 3.0 MW	0945-1105
Lab	LI120	Salvin C	1.0 M	0845-0935
10152 Lec	HU102	Salvin C	3.2 3.0 MW	0945-1105
Lab	LI120	Salvin C	1.0 W	0845-0935
10153 Lec	HOL5	Salvin C	3.2 3.0 TR	0945-1105
Lab	HOL3	Salvin C	1.0 T	0845-0935
Above class meets at the Hollister Briggs site.				
10154 Lec	HOL5	Salvin C	3.2 3.0 TR	0945-1105
Lab	HOL3	Salvin C	1.0 R	0845-0935
Above class meets at the Hollister Briggs site.				
10155 Lec	HU102	STAFF S	3.2 3.0 TR	0945-1105
Lab	LI171	STAFF S	1.0 F	1010-1100
10157 Lec	HU102	STAFF S	3.2 3.0 TR	0945-1105
Lab	LI171	STAFF S	1.0 F	1110-1200
10160 Lec	HU103	White S	3.2 3.0 MW	1250-0210
Lab	LI171	White S	1.0 F	1210-0100
10162 Lec	HU103	White S	3.2 3.0 MW	1250-0210
Lab	LI171	White S	1.0 F	0110-0200

continued

Be Aware

You MAY NOT take courses that overlap (courses that meet at the same day and time)!

ENGLISH COMPOSITION AND READING COURSE SEQUENCE

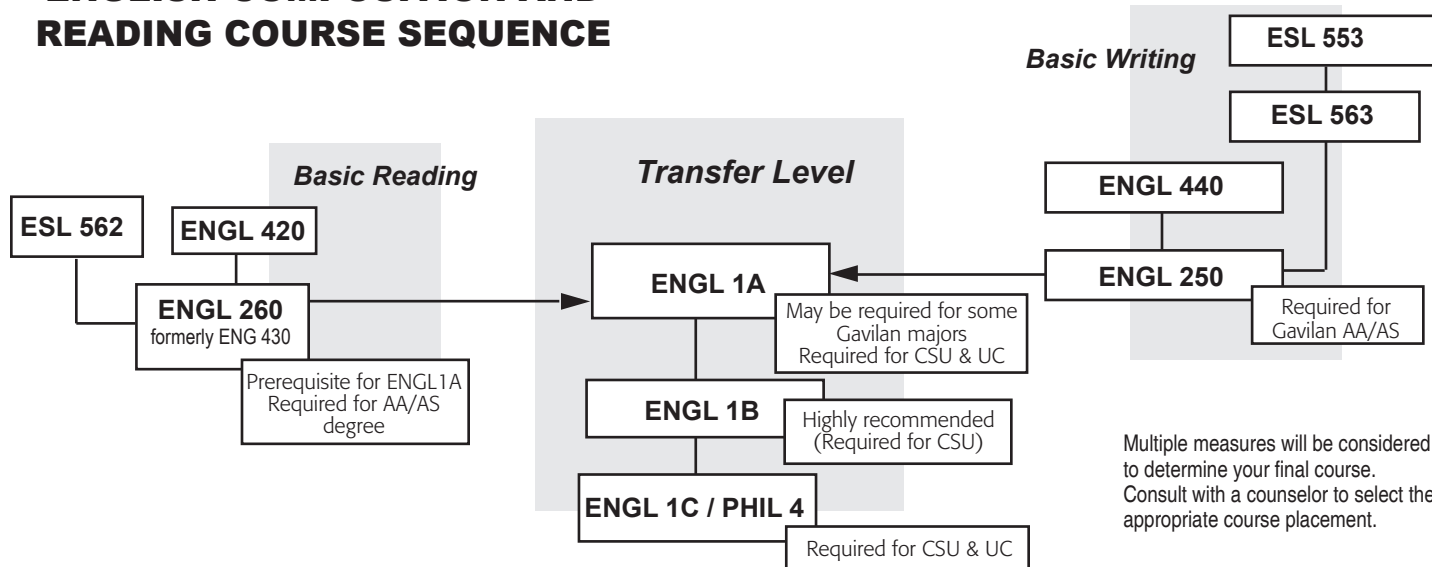

CRN	Type	Room	Instructor	Hrs.	Units	Days	Begin-End
10166	Lec	HU102	Hooper J	3.2	3.0	TR	0230-0350
	Lab	LI120	Hooper J	1.0		T	0400-0450
10168	Lec	HU102	Hooper J	3.2	3.0	TR	0230-0350
	Lab	LI120	Hooper J	1.0		R	0400-0450
10164	Lec	SS203	Estrada-Mack T	3.2	3.0	MW	0400-0520
	Lab	LI120	Estrada-Mack T	1.0		M	0530-0620
10165	Lec	SS203	Estrada-Mack T	3.2	3.0	MW	0400-0520
	Lab	LI120	Estrada-Mack T	1.0		W	0530-0620
10169	Lec	HU103	Arora S	3.2	3.0	MW	0700-0820
	Lab	LI120	Arora S	1.0		M	0830-0920
10170	Lec	HU103	Arora S	3.2	3.0	MW	0700-0820
	Lab	LI120	Arora S	1.0		W	0830-0920
10173	Lec	MHG12	STAFF S	3.2	3.0	TR	0700-0820
	Lab	MHG12	STAFF S	1.0		T	0830-0920
Above class meets at Morgan Hill Community site.							
10175	Lec	MHG12	STAFF S	3.2	3.0	TR	0700-0820
	Lab	MHG12	STAFF S	1.0		R	0830-0920
Above class meets at Morgan Hill Community site.							

LATE START ENGL 250 CLASSES:

10936	Lec	SS111	Gatewood J	6.8	3.0	TR	0230-0540
	Lab	LI120	Gatewood J	2.0		F	0100-0250
10/26/09 - 12/19/09 Above late-start class meets for eight weeks during the second half of the semester.							
10937	Lec	SS111	Gatewood J	6.8	3.0	TR	0230-0540
	Lab	LI120	Gatewood J	2.0		F	0300-0450
10/26/09 - 12/19/09 Above late-start class meets for eight weeks during the second half of the semester.							

LEARNING COMMUNITY ENGL 250 CLASSES:

10149	Lec	MHG4	Sandler S	3.2	3.0	TR	0910-1030
	Lab	MHG4	Sandler S	1.0		T	0810-0900
Above class meets at Morgan Hill Community site. This class is part of a Learning Community if you enroll you must also enroll in CD 5, CRN 10485.							
10150	Lec	MHG4	Sandler S	3.2	3.0	TR	0910-1030
	Lab	MHG4	Sandler S	1.0		R	0810-0900
Above class meets at Morgan Hill Community site. This class is part of a Learning Community if you enroll you must also enroll in CD 5, CRN 10485.							

FIRST YEAR EXPERIENCE ENGL 250 CLASSES:

10179	Lec	HU102	Hooper J	3.2	3.0	MW	1120-1240
	Lab	LI120	Hooper J	1.0		M	1010-1100
This class is part of a First Year Experience learning community. If you enroll you must also enroll in ENGL 260 CRN # 10189.							
10180	Lec	HU102	Hooper J	3.2	3.0	MW	1120-1240
	Lab	LI120	Hooper J	1.0		W	0230-0320
This class is part of a First Year Experience learning community. If you enroll you must also enroll in ENGL 260 CRN# 10921.							
10182	Lec	HU102	Smith K	3.2	3.0	TR	1250-0210
	Lab	LI120	Smith K	1.0		T	1010-1100
This class is part of a First Year Experience learning community. If you enroll you must also enroll in ENGL 260 CRN# 10190.							
10183	Lec	HU102	Smith K	3.2	3.0	TR	1250-0210
	Lab	LI120	Smith K	1.0		R	1010-1100
This class is part of a First Year Experience learning community. If you enroll you must also enroll in ENGL 260 CRN # 10922.							

PUEENTE LEARNING COMMUNITY ENGL 250 CLASSES:

10158	Lec	PH102	Sandler S	3.2	3.0	TR	1120-1240
	Lab	LI120	Sandler S	1.0		T	1255-0145
Students enrolled in this class will participate in the PUEENTE program and will need to complete 10 hours of mentoring. Required: Complete an application with the PUEENTE counselor prior to registration. This class is part of a Learning Community. Students must also enroll in GUID 1, CRN 10819. Students must attend a mandatory Puente Welcome on Wednesday, August 26, from 8:30 am - 1 pm in SS206. See ad on page 91.							
10159	Lec	PH102	Sandler S	3.2	3.0	TR	1120-1240
	Lab	LI120	Sandler S	1.0		R	1255-0145
Students enrolled in this class will participate in the PUEENTE program and will need to complete 10 hours of mentoring. Required: Complete an application with the PUEENTE counselor prior to registration. This class is part of a learning community. Students must also enroll in GUID 1, CRN 10819. Students must attend a mandatory Puente Welcome on Wednesday, August 26, from 8:30 am - 1 pm in SS206. See ad on page 91.							

Get College Credit for Working or Volunteering!

**Cooperative Work Experience**

is available to day, evening, full-time and part-time students.

If your job or volunteer work is directly related to your education or occupational goals sign up for:

CWE 190: Occupation Work Experience Education

If your job or volunteer work is not directly related to your educational goals sign up for:

CWE 192: General Work Experience Education

Call 408-848-4813 or email ssweeney@gavilan.edu for more information.

CRN Type Room Instructor Hrs. Units Days Begin-End**ENGL 260 Preparation for College Reading**

Transferable: No; GAV-GE:A3

This is a course presenting strategies in the technique and practice of college level critical reading and thinking skills. PREREQUISITE: Completion of English 420 or ESL 562 with a grade of 'C' or better or Assessment recommendation.

10187	Lec	HU103	Collins J	3.2	3.0	TR	0810-0930
10196	Lec	HOL2	Hull K	3.3	3.0	F	0900-1205
Above class meets at the Hollister Briggs site.							
10184	Lec	SS111	Hull K	3.2	3.0	MW	0945-1105
10195	Lec	HU102	Tracey I	3.3	3.0	F	1010-0115
10186	Lec	SS203	Hull K	3.2	3.0	MW	1120-1240
10188	Lec	MHG12	Hooper J	3.2	3.0	TR	0530-0650
Above class meets at Morgan Hill Community site.							
10961	Lec	HU103	Arora S	3.2	3.0	MW	0530-0650

1 Your ENGL 260 class has a theme.
2
3 See list on page 91.

FIRST YEAR EXPERIENCE ENGL 260 CLASSES:

10190	Lec	HU102	Smith K	3.2	3.0	TR	1120-1240
This class is part of a First Year Experience learning community. If you enroll you must also enroll in ENGL 250 CRN# 10182.							
10922	Lec	HU102	Smith K	3.2	3.0	TR	1120-1240
This class is part of a First Year Experience learning community. If you enroll in you must also enroll in ENGL 250 CRN #10183. Above class meets at the Hollister Briggs site.							
10189	Lec	HU102	Hooper J	3.2	3.0	MW	1250-0210
This class is part of a First Year Experience learning community. If you enroll you must also enroll in ENGL 250 CRN # 10179.							
10921	Lec	HU102	Hooper J	3.2	3.0	MW	1250-0210
This class is part of a First Year Experience learning community. If you enroll you must also enroll in ENGL 250 CRN# 10180.							

CRN Type Room Instructor Hrs. Units Days Begin-End

ENGL 420 Reading Improvement

Transferable: No

This is a practical, "how to" course teaching various methods of learning and reading college material. Using group and individual instruction in vocabulary, comprehension, and study skills, the students will increase their ability to survive academically, to profit, grow and succeed in all college courses, and to enjoy reading and learning. Units earned in this course do not count toward the associate degree and/or certain certificate requirements. PREREQUISITE: Satisfactory score on the English placement examination.

10198	Lec	SS203	Tracey I	3.2	3.0	MW	0810-0930
	Lab	SS110	Tracey I	1.0		F	0810-0900
10199	Lec	SS203	Tracey I	3.2	3.0	MW	0810-0930
	Lab	SS110	Tracey I	1.0		F	0910-1000
10207	Lec	SS111	Hirasuna S	3.2	3.0	TR	0945-1105
	Lab	LI120	Hirasuna S	1.0		T	1120-1210
10208	Lec	SS111	Hirasuna S	3.2	3.0	TR	0945-1105
	Lab	LI120	Hirasuna S	1.0		R	1120-1210
10209	L/L	HOL5	Parker V	4.6	3.0	TR	0530-0735

Above class meets at the Hollister Briggs site.

FIRST YEAR EXPERIENCE ENGL 420 CLASSES:

10202	Lec	HU103	Warren K	3.2	3.0	MW	0945-1105
	Lab	LI171	Warren K	1.0		T	1010-1100

This class is part of a First Year Experience Learning Community. If you enroll in this class you must also enroll in ENGL 440, # 10213.

10203	Lec	HU103	Warren K	3.2	3.0	MW	0945-1105
	Lab	SS216	Warren K	1.0		M	0100-0150

This class is part of a First Year Experience Learning Community. If you enroll in this class you must also enroll in ENGL 440, #10211.

③

10200	Lec	SS203	Roscher J	3.2	3.0	TR	1120-1240
	Lab	SS216	Roscher J	1.0		T	1010-1100

This class is part of a First Year Experience learning community. If you enroll you must also enroll in ENGL 440 CRN # 10219.

③

10201	Lec	SS203	Roscher J	3.2	3.0	TR	1120-1240
	Lab	SS216	Roscher J	1.0		R	1010-1100

This class is part of a First Year Experience learning community. If you enroll you must also enroll in ENGL 440 CRN # 10218.

ENGL 439 Basic Grammar and Reading

Transferable: No

This is a remediation course introducing basic reading and writing strategies, as well as study skills. Group and individual instruction will be used to build vocabulary, increase reading comprehension, develop study skills, and apply basic grammar to writing. Units earned in this course do not count toward the associate degree and/or certain certificate requirements. This is a pass/no pass course. ADVISORY: Assessment recommendation.

10210	Lec	PB4A	White S	3.2	4.0	MW	0945-1105
	Lab	SS111	White S	3.3		F	0900-1205

**ENGL 749
WRITER'S
WORKSHOP**

Instructor: Kimberly Smith

Wednesday, 1:30 - 4:30 pm
480 Eighth Street, Gilroy in the
Family Academy Room.

See listing in the Noncredit
section beginning on page 127

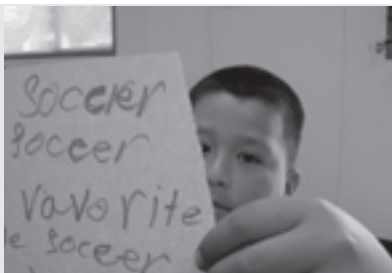

We help learners of all ages!

- Free tutoring for kids, teens and parents.
- Fun writing games and prompts.
- A relaxed and friendly atmosphere.

1st Year Experience

is a program in place in many schools across the country. These programs are in response to much research supporting smaller schools, interdisciplinary studies, and community building. So what is FYE? At Gavilan, this program links fundamental courses together. By studying and working together with your classmates and instructors, you will develop a stronger network of support. Students who enroll in FYE often report higher GPA, increased involvement in school, more friends, greater ability to meet goals, and stronger critical thinking, reading, and writing abilities.

Mark your calendars! This semester we are also offering two Friday First Year Seminars from 1-3:30 on Friday, September 25 and Friday, October 23.

The following classes are part of a First Year Experience learning community. You must enroll in both courses.

ENGL 250 Practical Writing

10179	Lec	HU102	Hooper J	3.2	3.0	MW	1120-1240
	Lab	LI120	Hooper J	1.0		M	1010-1100

and

ENGL 260 Preparation for College Reading

10189	Lec	HU102	Hooper J	3.2	3.0	MW	1250-0210
-------	-----	-------	----------	-----	-----	----	-----------

or

ENGL 250 Practical Writing

10180	Lec	HU102	Hooper J	3.2	3.0	MW	1120-1240
	Lab	LI120	Hooper J	1.0		W	0230-0320

and

ENGL 260 Preparation for College Reading

10921	Lec	HU102	Hooper J	3.2	3.0	MW	1250-0210
-------	-----	-------	----------	-----	-----	----	-----------

or

ENGL 250 Practical Writing

10182	Lec	HU102	Smith K	3.2	3.0	TR	1250-0210
	Lab	LI120	Smith K	1.0		T	1010-1100

and

ENGL 260 Preparation for College Reading

10190	Lec	HU102	Smith K	3.2	3.0	TR	1120-1240
-------	-----	-------	---------	-----	-----	----	-----------

or

ENGL 250 Practical Writing

10183	Lec	HU102	Smith K	3.2	3.0	TR	1250-0210
	Lab	LI120	Smith K	1.0		R	1010-1100

and

ENGL 260 Preparation for College Reading

10922	Lec	HU102	Smith K	3.2	3.0	TR	1120-1240
-------	-----	-------	---------	-----	-----	----	-----------

Don't forget

A counselor's signature is required if you take over 17.99 units (spring/fall) or over 5.99 units (summer).

You do not need a counselor's signature to register for a class with a prerequisite that was successfully completed at Gavilan.

Classroom Locations: Refer to "How to Use This Schedule" on page 5.

FIRST YEAR EXPERIENCE cont.

Is this your first year at Gavilan? Looking for a community of people like you? Then this learning community program is specially designed for you. The first year of college can be challenging for many students. By studying and working together with your classmates and instructors, in this program you'll develop a strong network of support to help you succeed. You'll improve your reading and writing skills and also explore options for majors, transferring, and careers. Building a strong foundation in your first year will put you on the road to success throughout your college experience.



The Program: Students will take reading and writing together because these skills are needed to succeed in college classes.

The following classes are part of a First Year Experience learning community. You must enroll in both courses.

ENGL 420 Reading Improvement

10203	Lec	HU103	Warren K	3.2	3.0	MW	0945-1105
	Lab	SS216	Warren K	1.0		M	0100-0150

and

ENGL 440 Basic Writing

10211	Lec	HU103	Warren K	3.2	3.0	MW	1120-1240
	Lab	LI120	Warren K	1.0		W	0100-0150

_____ or _____

ENGL 420 Reading Improvement

10202	Lec	HU103	Warren K	3.2	3.0	MW	0945-1105
	Lab	LI171	Warren K	1.0		T	1010-1100

and

ENGL 440 Basic Writing

10213	Lec	HU103	Warren K	3.2	3.0	MW	1120-1240
	Lab	LI171	Warren K	1.0		R	1010-1100

_____ or _____

ENGL 420 Reading Improvement

10201	Lec	SS203	Roscher J	3.2	3.0	TR	1120-1240
	Lab	SS216	Roscher J	1.0		R	1010-1100

and

ENGL 440 Basic Writing

10218	Lec	SS203	Roscher J	3.2	3.0	TR	1250-0210
	Lab	LI120	Roscher J	1.0		T	0230-0320

_____ or _____

ENGL 420 Reading Improvement

10200	Lec	SS203	Roscher J	3.2	3.0	TR	1120-1240
	Lab	SS216	Roscher J	1.0		T	1010-1100

and

ENGL 440 Basic Writing

10219	Lec	SS203	Roscher J	3.2	3.0	TR	1250-0210
	Lab	LI120	Roscher J	1.0		R	0230-0320

ENGL 440 Basic Writing

Transferable: No

This is an intensive study and application of basic grammar, sentence, and essay writing skills within the context of composing short essays. Units earned in this course do not count toward the associate degree and/or certain certificate requirements. PREREQUISITE: Satisfactory score on the English placement examination.

10220	Lec	SS111	Bragger M	3.2	3.0	TR	0810-0930
	Lab	LI120	Bragger M	1.0		F	0810-0900
10221	Lec	SS111	Bragger M	3.2	3.0	TR	0810-0930
	Lab	LI120	Bragger M	1.0		F	0910-1000
10214	Lec	SS203	Crook E	3.2	3.0	MW	0945-1105
	Lab	LI120	Crook E	1.0		M	1120-1210
10215	Lec	SS203	Crook E	3.2	3.0	MW	0945-1105
	Lab	LI120	Crook E	1.0		W	1120-1210
10216	Lec	HU103	Crook E	3.2	3.0	TR	1120-1240
	Lab	LI171	Crook E	1.0		R	1250-0140
10217	Lec	HU103	Crook E	3.2	3.0	TR	1120-1240
	Lab	LI171	Crook E	1.0		T	1250-0140

10225	Lec	SS111	Diehl K	3.2	3.0	MW	0530-0650
	Lab	LI120	Diehl K	1.0		M	0700-0750

10226	Lec	SS111	Diehl K	3.2	3.0	MW	0530-0650
	Lab	LI120	Diehl K	1.0		W	0700-0750

10222	Lec	HOL5	Parker V	3.2	3.0	TR	0745-0905
	Lab	HOL5	Parker V	1.0		T	0910-1000

Above class meets at the Hollister Briggs site.

10223	Lec	HOL5	Parker V	3.2	3.0	TR	0745-0905
	Lab	HOL5	Parker V	1.0		R	0910-1000

Above class meets at the Hollister Briggs site.

FIRST YEAR EXPERIENCE ENGL 440 CLASSES:

10211	Lec	HU103	Warren K	3.2	3.0	MW	1120-1240
	Lab	LI120	Warren K	1.0		W	0100-0150

This class is part of a First Year Experience Learning Community. If you enroll you must also enroll in ENGL 420, # 10203.

10213	Lec	HU103	Warren K	3.2	3.0	MW	1120-1240
	Lab	LI171	Warren K	1.0		R	1010-1100

This class is part of a First Year Experience Learning Community. If you enroll you must also enroll in ENGL 420, # 10202.

10218	Lec	SS203	Roscher J	3.2	3.0	TR	1250-0210
	Lab	LI120	Roscher J	1.0		T	0230-0320

This class is part of a First Year Experience learning community. If you enroll you must also enroll in ENGL 420 CRN # 10201.

10219	Lec	SS203	Roscher J	3.2	3.0	TR	1250-0210
	Lab	LI120	Roscher J	1.0		R	0230-0320

This class is part of a First Year Experience learning community. If you enroll you must also enroll in ENGL 420 CRN # 10200.

ENGLISH AS A SECOND LANGUAGE

All new ESL students must go through the ESL assessment process. See page 134.

Todos los nuevos estudiantes de ESL deben tomar el examen de nivelación de ESL. Consulte la página 134.

ESL 501 Survival ESL I

Transferable: No

This is a course in survival English for students with little or no oral or written English competency. It will give students basic vocabulary and familiarity in life skill areas such as the family, food, health, and occupations. The course integrates listening, speaking, reading, and writing. (ESL 501, 502, and 503 are sequential courses that may be taken in full form or in halves, preferably A before B.) This is a pass/no pass course. ADVISORY: ESL assessment recommendation

10063	L/L	HOL4	STAFF S	10.0	6.0	MTWRF	1115-0110
-------	-----	------	---------	------	-----	-------	-----------

Above class meets at the Hollister Briggs site.

CRN Type Room Instructor Hrs. Units Days Begin-End

ESL 503 Survival ESL III

Transferable: No

This is a third course in survival English for students with beginning oral or written English competency. It will reinforce basic skills learned and continue to develop vocabulary and ease of communication in life skill areas such as the family, the larger community, health, employment, and leisure activities. The course integrates listening, speaking, reading, and writing. (ESL 501, 502, and 503 are sequential courses that may be taken in full form or in halves, preferably A before B.) This is a pass/no pass course. ADVISORY: ESL 502 or ESL 502A and ESL 502B or ESL assessment recommendation.

10064 L/L HOL4 Howel J 10.0 6.0 MTWRF 0910-1105
Above class meets at the Hollister Briggs site.

ESL 510A Basic ESL I

Transferable: No

This is an intensive, integrated-skill course for students with little English. Through listening, speaking, reading and writing activities, students learn to use the structures of English with increasing accuracy, while gaining basic life skills. ADVISORY: ESL Assessment Recommendation.

10065 L/L CJ500 Cisneros N 9.0 9.0 MTWRF 0950-1120
ARR TBA 2.0
10066 L/L CJ500 Polizzotto J 9.0 9.0 MTWRF 0810-0940
ARR TBA 2.0

ESL 510B Basic ESL II

Transferable: No

This course is a continuation of ESL 510A. This is an intensive, integrated-skill program for students who function in a limited way in English. Through listening, speaking, reading and writing activities, students continue learning to use the structures of English with increasing accuracy, while gaining further basic life skills. ADVISORY: ESL 510A or ESL assessment recommendation.

10067 L/L CJ500 Baameur K 9.0 9.0 MTWRF 1130-0100
ARR TBA 2.0

ESL 521 Beginning ESL Listening/Speaking

Transferable: No

This course develops basic listening and speaking skills, moving from a functional survival context to academic readiness. Activities are directed at providing practice through listening exercises, role-play, pair work, small and large group discussion, interviews, and oral presentations. ADVISORY: ESL 510B or ESL Assessment Test Recommendation. Recommended concurrent enrollment in ESL 522 and 523.

10068 L/L LI100 Lawn B 4.2 4.0 MWF 1100-1210
ARR TBA 1.0

ESL 522 Beginning ESL Reading/Vocabulary

Transferable: No

This course begins the development of reading skills and vocabulary through the application of different reading strategies to a variety of selections on topics of interest to academically-bound students. ADVISORY: ESL 510B or 510C or Assessment recommendation. Recommended concurrent enrollment in ESL 521 and 523.

10242 Lec HU101 Guzman D 3.2 3.0 TR 0945-1105

ESL 523 Beginning ESL Grammar/Writing

Transferable: No

This is a beginning grammar/writing course for students with very basic grammar. The focus is on basic grammatical structures, punctuation and sentence skills. ADVISORY: ESL 510B or ESL Assessment Test recommendation. Recommended concurrent enrollment in ESL 521 and ESL 522.

10069 L/L HU104 Wexler L 5.2 5.0 MTWR 0810-0915
ARR TBA 1.0

CRN Type Room Instructor Hrs. Units Days Begin-End

ESL 527 Integrated Reading-Writing I

Transferable: No

This is the first course in a series of integrated skills courses designed to develop the reading, writing and grammar skills of ESL students. This beginning course focuses on vocabulary development, basic reading strategies and comprehension, basic grammar and beginning writing skills (sentence level and basic paragraphs.) The aim of this course is to assist beginning level students in becoming more literate while participating in holistic reading and writing activities based on engaging multicultural topics. PREREQUISITE: ESL 510B or ESL 503, or ESL assessment recommendation.

10094 Lec HU104 Shelley A 6.0 6.0 TR 0630-0930

10095 Lec HOL6 Staff 5.7 6.0 MWF 0630-0805
Above class meets at the Hollister Briggs site.

ESL 531 Intermediate ESL Listening/Speaking I

Transferable: No

In this course, listening and speaking skills are developed through extended listening exercises, open-ended dialogues, pair and group discussions, oral interviews, and oral reports. PREREQUISITE: ESL 521 with a grade of 'C' or better or ESL Assessment Recommendation. Recommended concurrent enrollment in ESL 532 and 533.

10251 Lec HU101 Sanidad M 4.2 4.0 MWF 0945-1055
ARR TBA 1.0

ESL 532 Intermediate ESL Reading/Vocabulary I

Transferable: No

This course continues the development of reading skills and vocabulary through the application of different reading strategies to a variety of selections on topics of interest to academically-bound students. PREREQUISITE: ESL 522 with a grade of 'C' or better or ESL assessment recommendation. Recommended concurrent enrollment in ESL 531 and 533.

10078 Lec LI100 Wexler L 3.2 3.0 TR 1100-1220

ESL 533 Intermediate ESL Grammar/Writing I

Transferable: No

This course involves the practice and refinement of sentence and paragraph skills, structure and punctuation. Students will learn basic use of the computer as a writing tool. PREREQUISITE: ESL 523 with a grade of C or better or ESL Assessment Test recommendation. ADVISORY: Recommended concurrent enrollment in ESL 531 and ESL 532.

10084 L/L LI100 Lawn B 5.2 5.0 MTWR 1225-0130
ARR TBA 1.0

ESL 537 Integrated Reading/Writing II

Transferable: No

This is the second course in a series of integrated skills courses designed to continue the development of reading, writing and grammar skills of low-intermediate ESL students. The course focuses on vocabulary development through the application of different reading strategies to a variety of selections of topics of interest to academically-bound students. It also involves the practice and refinement of sentence and paragraph skills, structure and pronunciation. PREREQUISITE: ESL 523 and ESL 522, or ESL 527, or ESL Assessment Recommendation.

10862 Lec HU101 Guzman D 6.0 6.0 TR 0630-0930

ESL 541 Intermediate ESL Listening/Speaking II

Transferable: No

This course expands listening and speaking skills through extended listening exercises, open-ended dialogues, pair and group discussions, oral interviews, and oral reports. Students broaden vocabulary while listening to and speaking in both formal and informal, conversational and academic situations. PREREQUISITE: ESL 531 with a grade of 'C' or better or ESL assessment recommendation. Recommended concurrent enrollment in ESL 542 and 543.

10253 Lec HU104 Wexler L 4.2 4.0 MWF 1225-0135
ARR TBA 1.0

Please help protect Gavilan's park-like setting by properly disposing of litter and recycling.

CRN Type Room Instructor Hrs. Units Days Begin-End

ESL 542 Intermediate ESL Reading/Vocabulary II

Transferable: No

This course begins the expansion of reading skills and vocabulary development through the application of different reading strategies to a variety of selections on topics of interest to academically-bound students including selections from literature. PREREQUISITE: ESL 532 with a grade of 'C' or better or ESL Assessment Recommendation. Recommended concurrent enrollment in ESL 541 and 543.

10261 Lec HU101 Carillo L 3.2 3.0 TR 0810-0930

ESL 543 Intermediate ESL Grammar/Writing II

Transferable: No

This course involves the expansion of sentence and paragraph skills, structure, and punctuation. Students will learn basic use of the computer as a writing tool. PREREQUISITE: ESL 533 with a grade of C or better or ESL assessment recommendation. ADVISORY: Recommended concurrent enrollment in ESL 541 and ESL 542.

10085 L/L HU104 Campbell K 5.2 5.0 TWR 0945-1050
ARR TBA 1.0

ESL 546 Introduction to Computers for ESL Students

Transferable: No

Introduction to basic computer hardware functions and terminology; overview of Windows operating environment and word processing for ESL students. ADVISORY: CSIS 122. Eligible for Gavilan College ESL Program Intermediate.

10086 L/L PB14 Cisneros N 1.0 1.0 W 1130-1220

ESL 552 Advanced ESL Reading/Vocabulary I

Transferable: No

This course focuses on academic and critical thinking skills needed to increase reading comprehension and efficiency. Emphasis is on analyzing, making inferences, taking notes, supporting opinions, summarizing and expanding vocabulary. Readings are from academic texts and literature. PREREQUISITE: ESL 542 with a grade of 'C' or better or ESL assessment recommendation. Recommended concurrent enrollment in ESL 553 and 554.

10262 Lec PH102 Wexler L 4.2 4.0 MWF 0945-1055

ESL 553 Advanced ESL Composition I

Transferable: No

This course is a composition course for ESL students that develops college composition skills through a review of the parts and elements of the English paragraph and an introduction to the essay form. The course focuses on the development of a paragraph and expands to the writing of multiple paragraphs in an essay. Basic rhetorical patterns and methods of organization are covered using the multiple-draft approach to writing. PREREQUISITE: ESL 543 with a grade of C or better or ESL Assessment Test recommendation. ADVISORY: Recommended concurrent enrollment in ESL 552 and ESL 554.

10090 Lec LI100 Cisneros N 5.2 5.0 MTWR 0810-0915
ARR TBA 1.0

ESL 554 Advanced ESL Grammar I

Transferable: No

This course is designed to help students improve their grammar usage so that they will be able to expand their use of grammar structures in oral and written communication. Students begin the study of more sophisticated grammar structures such as past and future perfect, passive voice, and modal auxiliaries for past time, and they review perfect and modals for present and future time. Students will enhance their understanding of grammar by comparing and contrasting new and previously encountered structures and better appreciate the subtleties of English grammar. PREREQUISITE: ESL 543 with a grade of 'C' or better or ESL Assessment Test Recommendation. ADVISORY: Recommended concurrent enrollment in ESL 552 and ESL 553.

10091 L/L HU104 Campbell K 5.2 5.0 MTRF 1110-1215
ARR TBA 1.0

ESL 562 Advanced ESL Reading/Vocabulary II

Transferable: No

This course prepares ESL students for mainstream college classes by reviewing a variety of reading skills, strategies, and topics from different academic disciplines. Students expand their academic vocabulary and read short stories or a novel for literary appreciation. PREREQUISITE: ESL 552 with a grade of 'C' or better or ESL assessment recommendation. Recommended concurrent enrollment in ESL 561 and/or ESL 564 and ESL 563.

10263 Lec HU101 Campbell K 4.2 4.0 MWF 0810-0920

OVERVIEW of ESL COURSES

NON CREDIT

LIFE SKILLS

ESL 777	ESL 778
ESL 779	ESL 780
ESL 781	ESL 782

VOCATIONAL

VESL ESL 704A/B

To move from noncredit to credit ESL classes students must take an ESL assessment.

CREDIT

SURVIVAL TRACK

ACADEMIC TRACK

ESL 501	→	Basic	510A		
ESL 502	→		510B		
ESL 503	→	Beginning	521 L/S	522R	523GW
		Intermediate I	531 L/S	532R	533GW
		Intermediate II	541 L/S	542R	543GW
		Advanced I		552R	553W 554G
		Advanced II	561 L/S	562R	563W 564G

SUPPLEMENTARY ESL COURSES:

- ESL 546 Intro Computers/ESL
- ESL 556 Intro Competency/ESL
- ESL 581 Pronunciation I
- ESL 582 Pronunciation II
- ESL 584 Culture through Film
- ESL 585 Editing for ESL Writers

ENGL 260 ENGL 250

ACADEMIC PROGRAMS or VOCATIONAL PROGRAMS

GRADUATION INFORMATION



Call 408-848-4737 for details about the graduation process.

The deadline for filling out a petition for graduation for fall is Monday, October 12th.

Admissions & Records

CRN Type Room Instructor Hrs. Units Days Begin-End

ESL 563 Advanced ESL Composition II

Transferable: No

This course, which is designed for ESL students, refines and further expands college composition skills through the writing of essays using the multiple-draft approach to writing. The course focuses on the structuring and development of an essay with the use of personal examples. Students write in response to a variety of prompts using different rhetorical patterns such as classification, cause/effect, and comparison/contrast. PREREQUISITE: ESL 553 with a grade of "C" or better or ESL Assessment Test recommendation. ADVISORY: Recommended concurrent enrollment in ESL 562 and ESL 564.

10092	Lec ARR	LI100	Lawn B TBA	5.2 1.0	5.0	TWRF	0945-1050
-------	------------	-------	---------------	------------	-----	------	-----------

ESL 564 Advanced ESL Grammar II

Transferable: No

This course is designed to expand grammar usage to include adjective, noun, and adverb clauses in oral and written communication. Students learn the meaning and use of clause connectors and are introduced to conditionals, both real and unreal. These grammar structures constitute some of the most complex structures in English and expose students to a rich variety of structures that can effectively enhance their oral and written expression. PREREQUISITE: ESL 554 with a grade of 'C' or better or ESL Assessment Recommendation. ADVISORY: Recommended concurrent enrollment in ESL 562 and ESL 563.

10093	L/L ARR	HU101	Sanidad M TBA	5.2 1.0	5.0	MTWR	1110-1215
-------	------------	-------	------------------	------------	-----	------	-----------

Film: see ENGL 2C, HUM 3, 4

Foreign Languages: See Chinese (CHN), French (FRNH), Japanese (JPN) and Spanish (SPAN)

FRENCH

FRNH 1A Elementary French

Transferable: CSU, UC; CSU-GE:C2, IGETC:6A; GAV-GE:C2

French 1A is a multi-skilled beginning level class with emphasis on understanding and speaking French. Students are introduced to the cultures and customs of various French-speaking countries.

10588	Lec	SS110	Sanidad M	5.2	5.0	MTWR	0810-0915
-------	-----	-------	-----------	-----	-----	------	-----------

FRNH 2A Intermediate French

Transferable: CSU

In French 2A, students further develop skills acquired in first year French: they review grammatical structures and expand their vocabulary; they increase their communicative ability through the reading and discussion of excerpts of French literature and cultural texts of various francophone countries and written composition. PREREQUISITE: French 1B or equivalent.

10591	L/L	LI100	Maxwell K	6.4	5.0	MTWR	0230-0350
-------	-----	-------	-----------	-----	-----	------	-----------

FRNH 8A Conversational French

Transferable: CSU

This beginning course emphasizes the sound system, pronunciation, and conversational skills used in everyday French but also covers vocabulary building and grammar as well. Students are introduced to the culture of a letter grade or pass/no pass.

10598	Lec	LI100	Maxwell K	3.3	3.0	T	0600-0905
-------	-----	-------	-----------	-----	-----	---	-----------

FRNH 23 Independent Study

Transferable: CSU

Designed to afford selected students specialized opportunities for exploring areas at the independent study level. The courses may involve extensive library work, research in the community, or special projects. May be repeated until six units of credit are accrued. This course has the option of a letter grade or pass/no pass. REQUIRED: The study outline prepared by the student and the instructor must be filed with the department and the dean.

10595	Ind	SS104	Sanidad M	2.0			
-------	-----	-------	-----------	-----	--	--	--

CRN Type Room Instructor Hrs. Units Days Begin-End

GEOGRAPHY

Geography: see also CSIS 61 (Geographic Info. Systems)

GEOG 1 Physical Geography

Transferable: CSU, UC; CSU-GE:B1, B3, IGETC:5A; GAV-GE:B1, B3; CAN:GEOG2

An introductory study of the basic physical elements of geography including climate, land forms, soils, water, and natural vegetation. The laboratory will include the tools and methods of geographers. ADVISORY: Eligible for English 250 and English 260.

10010	L/L	MHG12	Willahan D	5.4	3.0	TR	0945-1210
-------	-----	-------	------------	-----	-----	----	-----------

Above class meets at Morgan Hill Community site.

GEOLOGY

GEOG 1 Introduction to Geology

Transferable: CSU, UC; CSU-GE:B1, B3, IGETC:5A; GAV-GE:B1, B3; CAN:GEOG2

A study of the earth and the physical properties which modify the earth; minerals, rocks, geologic structures and processes. ADVISORY: Eligible for English 250 and English 260.

10362	L/L	SS206	Willahan D	6.6	4.0	TR	1250-0355
-------	-----	-------	------------	-----	-----	----	-----------

Government: see Political Science
Graphic Arts: see Art, CSIS, Digital Media

GUIDANCE

GUID 1 Self-Assessment and Career Development

Transferable: CSU; CSU-GE:E2; GAV-GE:E2

This course is designed to assist the student in learning more about personal values, personality, interests, exploration of career choice, and occupational opportunities through the use of various personal assessment instruments. The delivery options for this course also include online and self-paced formats. This course is also listed as PSYC 5. ADVISORY: Eligible for English 250 and English 260. \$12 fee will be charged for career assessment materials.

10833	Lec	CH105	Artega B	13.6	3.0	MTWR	0830-1140
-------	-----	-------	----------	------	-----	------	-----------

07/27/09 - 08/20/09

10810	Lec	CJ500	Godley J	3.2	3.0	TR	0105-0225
-------	-----	-------	----------	-----	-----	----	-----------

10812	Lec	HOL2	Lopez A	3.2	3.0	MW	0230-0350
-------	-----	------	---------	-----	-----	----	-----------

Above class meets at the Hollister Briggs site.

10813	Lec	SBHS-194	Caffiero J	3.2	3.0	MW	0400-0520
-------	-----	----------	------------	-----	-----	----	-----------

This class is part of the High Step Program. It will be offered at San Benito High School, room 194. This class is open to all students. For more information, see a Gavilan counselor.

10814	ONLINE	Sharboneau R		3.0			
-------	--------	--------------	--	-----	--	--	--

You must have an email account to take this course. Start your course by going to www.gavilan.edu/disted. Unless you have made prior arrangements with the instructor, you MUST log on by 11:59 pm on the first day of the semester. Late adds must login within 24 hours of adding this course. If you miss the deadline you may be dropped. For help, contact your instructor or email disted@gavilan.edu.

10458	ONLINE	Tenney L		3.0			
-------	--------	----------	--	-----	--	--	--

You must have an email account to take this course. Start your course by going to www.gavilan.edu/disted. Unless you have made prior arrangements with the instructor, you MUST log on by 11:59 pm on the first day of the semester. Late adds must login within 24 hours of adding this course. If you miss the deadline you may be dropped. For help, contact your instructor or email disted@gavilan.edu.

PUENTE LEARNING COMMUNITY GUID 1 CLASSES:

10819	Lec	LS106	Marquez C	3.2	3.0	MW	1120-1240
-------	-----	-------	-----------	-----	-----	----	-----------

Students enrolled in this class will participate in the PUENTE program and will need to complete 10 hours of mentoring. Required: Complete an application with the PUENTE counselor prior to registration. This class is part of a learning community. Students must also enroll in ENGL 250, CRN 10158 or 10159. Students must attend a mandatory Puente Welcome on Wednesday, August 26, from 8:30 am - 1 pm in SS206. See ad on page 91.

CRN Type Room Instructor Hrs. Units Days Begin-End

GUID 6 Life Skills for Higher Education

Transferable: CSU, UC; CSU-GE:E2; GAV-GE:E2

Evaluation and application of academic study methods to achieve subject matter mastery. Development of critical thinking skills, and application of reading, writing, note taking and test taking methods to improve personal strategies. Exploration of personal lifestyle and health factors, including the causes and management of stress, as it relates to academic success. Assessment of academic and career goals, selection of majors, and development of education plans. Topics covered include creative and realistic goal setting, academic and life management, college and community resources, library and Internet use, time management, and techniques to reduce math and science anxiety. This class will address a multitude of cultural learning styles, with emphasis on attaining professional, personal and academic goals in a diverse society. Topics from developmental psychology, learning theory and personality theory. ADVISORY: Eligible for English 250 and English 260.

10818 Lec PB3 TBA 2.3 2.0 M 0810-1015

GUID 22 Field Work and Service

Transferable: CSU

Supervised field work within the college and with local agencies. Students serve in useful group activities in leadership roles prescribed for them by faculty or community agencies. A maximum of six units may be completed. This is a pass/no pass course. REQUIRED: Learning contracts must be filled out and signed by the student and the supervising instructor.

10537 Fld Ex LI117 STAFF S 1.0 day/time - see instructor
Contact the Disability Resource Center (DRC) office.

GUID 28 Tutoring Techniques

Transferable: CSU

This course is designed to train students in effective tutoring skills, introduction to how people learn, teaching to modalities, and techniques of working with student anxiety. This course has the option of a letter grade or pass/no pass. ADVISORY: English 250.

10815 Lec PB4A Cribb G 3.0 1.0 TR 0815-0930
09/01/09 - 10/08/09

GUID 29 Tutoring Lab

Transferable: CSU

This course will allow students to gain valuable experience in the field of teaching. Students will practice the skills they have learned in Guidance 28. Guidance 29 may be repeated for a maximum of 2.0 units per semester and a maximum course total of 8.0 units. This is a pass/no pass course. ADVISORY: Completion of, or concurrent enrollment in Guidance 28.

10816 Lab LI116 King D 1.0
Open-entry, open-exit class.
10817 Lab LI116 King D 2.0
Open-entry, open-exit class.

GUID 530 Job Readiness

Transferable: No

This course is designed to provide a comprehensive, well-organized approach to assist individuals with the identification of occupational choices and the development of job readiness skills necessary to obtain and maintain employment in a competitive or supported work setting. May be repeated twice for credit. This course has the option of a letter grade or pass/no pass.

10538 Lec APE120/121 Franklin L 3.2 3.0 MW 0945-1105

GUID 550 Supervised Tutoring

Transferable: No

Laboratory class emphasizing college learning skills, appropriate study techniques, and learning assistance utilizing one-one-one or small group tutorial.

10914 Lab Computer Place
10915 Lab Digital Media Lab
10916 Lab Health Occupations Lab
10917 Lab Math Lab
10918 Lab Tutoring Center
10919 Lab Tutoring Center
10920 Lab Writing Center



**C'est Chic!
Learn French!**

Two new 3 unit classes!

FRNH 2A Elementary French

CRN 10591
Monday-Thursday
2:30-3:50 pm
Instructor: Kitty Maxwell

Prerequisite: French 1B or equivalent
You are eligible if you have successfully completed two years of high school French.
This course satisfies the general education Humanities (Area C-2) requirement under the AA/AS Degree and transfers to CSU as an elective.

FRNH 8A Conversational French

CRN 10598
Tuesday
6:00-9:05 pm
Instructor: Kitty Maxwell

No Prerequisites!
This course satisfies the general education Humanities (Area C-2) requirement under the AA/AS Degree and transfers to CSU as an elective.



The Puente Project is a two-semester program that combines three components: writing, counseling and mentoring to support students to transfer to four-year universities and colleges. The Guidance 1 course focuses on self assessment and career development. The English 250 course focuses on Mexican American/Latino literature. The program also includes a student leadership conference, university visits and mentor/student socials. The program is open to all eligible students. For more information, call Celia Marquez, Puente Co-Coordinator at 408-848-4807.

Required: Complete a program application with the Puente Counselor prior to registration. Students must attend a mandatory Puente Welcome on Wednesday, August 26, from 8:30 am - 1 pm in SS206.

GUID 1 CRN 10819 LS106 Marquez C MW 1120A-1240P
Students will need to complete 10 hours of mentoring.

Choose one of the ENGL 250 courses listed below:

ENGL 250 CRN 10158 PH102 Sandler S TuTh 1120A -1240P
LI120 Sandler S T 1255P - 0145P
ENGL 250 CRN 10159 PH102 Sandler S TR 1120A - 1240P
LI120 Sandler S R 1255P - 0145P

Your educational plan:

You are expected to take the responsibility for scheduling an appointment with a counselor, preferably at least once a semester. The purpose of this appointment is to develop, review and update your educational plan to ensure that you are taking the appropriate courses to meet your educational goal.

CRN Type Room Instructor Hrs. Units Days Begin-End

GUID 557 Learning Skills Assessment

Transferable: No

This course provides an assessment of the students' cognitive/perceptual abilities and basic skills academic achievement. The assessment results are used to determine the students' eligibility for Learning Disabilities Services, to develop individual educational plans, and/or to improve the students' understanding of their own learning strengths and weaknesses. The assessment is conducted on a one-to-one basis by appointment. Units earned in this course do not count toward the associate degree and/or certificate requirements. This is a pass/no pass course.

10539 Lab LI117 Burgman L .5 day/time - see instructor
Overson R

Open Entry-Open Exit. Make an appointment with the Disability Resource Center (DRC) office.

GUID 558 Learning Skills Laboratory

Transferable: No

The Learning Skills Laboratory is designed to assist students who are eligible to receive Learning Disabilities Services and/or have demonstrated academic deficits. The course content is individualized and based on Student Educational Contracts which are developed for each student. Students receive supplemental instruction, academic support, and learning strategy suggestions appropriate for their individual cognitive, perceptual, and academic strengths and weaknesses. Units earned do not count towards the associate degree and/or certificate requirements. This is a pass/no pass course. ADVISORY: Completion of Guidance 557 or demonstrated academic deficit.

Mandatory course orientation for the following classes will be conducted Tuesday, September 8 from 8:30-9:30 AM in the DRC Learning Skills Lab LI 117, Wednesday, September 9 from 12:30-1:30 PM in the DRC Learning Skills Lab LI 117, and Thursday, September 10 from 5:30-6:30 PM in the DRC Learning Skills Lab LI 117. Students need to attend one of the three meetings. Please contact Robert Overson at: roverson@gavilan.edu or (408) 846-4924.

10541 Lab LI116 Overson R .5 day/time - see instructor
Burgman L

Open Entry-Open Exit

10543 Lab LI116 Overson R 1.0 day/time - see instructor
Burgman L

Open Entry - OpenExit

10545 Lab LI116 Overson R 2.0 day/time - see instructor
Burgman L

Open Entry - Open Exit

GUID 561 Writing Skills

Transferable: No

This course is designed to teach basic writing skills to students who have demonstrated difficulty mastering written language and who are eligible to receive Learning Disability Services. Material is presented in a concrete, multi-sensory manner, and the class includes opportunity for immediate practice, repetition, and review. The course content includes grammar, sentence structure, and punctuation. Units earned do not count toward the associate degree and/or certificate requirements. This course has the option of a letter grade or pass/no pass. ADVISORY: Completion of Guidance 557 or demonstrated deficit in written language achievement. Recommended for students with verified learning disability.

10547 L/L PB4A Maringer J 2.0 1.0 TR 1250-0150

GUID 562 Directed Study Lab in Arithmetic

Transferable: No

This course is designed for students who have demonstrated difficulty in mastering arithmetic and who are eligible to receive Learning Disability Services. Course content parallels Mathematics 400. Material is presented in a concrete, multi-sensory manner, and the lab allows opportunity for immediate practice, questions, repetition, and review. Units earned do not count toward the associate degree and/or certificate requirements. This is a pass/no pass course. COREQUISITE: Concurrent enrollment in MATH 400. ADVISORY: Completion of GUID 557 and/or a demonstrated deficit in arithmetic. Recommended for students with verified learning disability.

10548 Lab PB4A Burgman L 3.2 1.0 TR 1120-1240

CRN Type Room Instructor Hrs. Units Days Begin-End

GUID 563A Directed Study Lab in Algebra

Transferable: No

This course is designed for students who have demonstrated difficulty mastering elementary algebra and who are eligible to receive Learning Disability Services. Course content parallels Mathematics 205A. Material is presented in a concrete, multi-sensory manner, and the lab allows opportunity for immediate practice, questions, repetition, and review. This is a pass/no pass course. COREQUISITE: Concurrent enrollment in MATH 205A is required. ADVISORY: Completion of GUID 557 or demonstrated deficit in mathematics. Recommended for students with verified learning disability.

10549 Lab APE120/121 Overson R 3.2 1.0 MW 1120-1240
ARR TBA 1.0

GUID 563B Directed Study Lab in Algebra

Transferable: No

This course is designed for students who have demonstrated difficulty mastering elementary algebra and who are eligible to receive Learning Disability Services. Course content parallels Mathematics 205B. Material is presented in a concrete, multi-sensory manner, and the lab allows opportunity for immediate practice, questions, repetition, and review. This is a pass/no pass course. COREQUISITE: Concurrent enrollment in MATH 205B is required. ADVISORY: Completion of GUID 557 or demonstrated deficit in mathematics. Recommended for students with verified learning disability.

10607 Lab APE120/121 Overson R 3.2 1.0 TR 0945-1105
ARR TBA 1.0

GUID 564 Directed Study Lab in Pre-Algebra

Transferable: No

This course is designed for students who are eligible to receive Learning Disability Services and/or who have demonstrated difficulty in mastering pre-algebra. The course content parallels Mathematics 402. The material is presented in a concrete, multi-sensory manner, and the lab environment allows opportunity for immediate practice questions, repetition and review. Units earned do not count towards the associate degree and/or certificate requirements. This is a pass/no pass course. COREQUISITE: Concurrent enrollment in MATH 402. ADVISORY: Completion of Guidance 557 and/or a demonstrated deficit in Mathematics. Recommended for students with verified learning disability.

10620 Lab PB4A Burgman L 3.2 1.0 MW 1120-1240

HEALTH EDUCATION

HE 1 Health Education

Transferable: CSU, UC; CSU-GE:E2; GAV-GE:E2

This course focuses on attaining individual awareness, critical-thinking skills and self-responsibility relating to personal health. The interaction of individual physical, psychological, social, emotional, spiritual and environmental factors in determining health status is developed through integration of major concepts. This course has the option of a letter grade or pass/no pass. ADVISORY: Eligible for English 250 and English 260.

10404 Lec LS106 Dodd S 3.2 3.0 TR 0945-1105

10406 Lec MHG12 Dodd S 3.3 3.0 W 0600-0905
Above class meets at Morgan Hill Community site.

10405 ONLINE Quatre S 3.0

You must have an email account to take this course. Start your course by going to www.gavilan.edu/disted. Unless you have made prior arrangements with the instructor, you MUST log on by 11:59 pm on the first day of the semester. Late adds must login within 24 hours of adding this course. If you miss the deadline you may be dropped. For help, contact your instructor or email disted@gavilan.edu.

Don't forget

A counselor's signature is required if you take over 17.99 units (spring/fall) or over 5.99 units (summer).

You do not need a counselor's signature to register for a class with a prerequisite that was successfully completed at Gavilan.

Have you met the prerequisite?

It's required!

Classroom Locations: Refer to "How to Use This Schedule" on page 5.

Check out *Classes offered at the satellite sites...*
Hollister classes - page 60. Morgan Hill classes - page 62.

CRN Type Room Instructor Hrs. Units Days Begin-End

HE 2 Human Sexuality

Transferable: CSU, UC; CSU-GE:E2; GAV-GE:E2

Assists students in gaining increased knowledge, appreciation, and respect for their own sexuality, as well as others. Approved by the Board of Registered Nursing for 54 hours of continuing education credit (Provider #00892). ADVISORY: Eligible for English 250 and English 260

10383 Lec LS106 Logan C 3.2 3.0 MW 0945-1105

10376 ONLINE Quatre S 3.0

 You must have an email account to take this course. Start your course by going to www.gavilan.edu/disted. Unless you have made prior arrangements with the instructor, you MUST log on by 11:59 pm on the first day of the semester. Late adds must login within 24 hours of adding this course. If you miss the deadline you may be dropped. For help, contact your instructor or email disted@gavilan.edu.

10378 ONLINE Quatre S 3.0

 You must have an email account to take this course. Start your course by going to www.gavilan.edu/disted. Unless you have made prior arrangements with the instructor, you MUST log on by 11:59 pm on the first day of the semester. Late adds must login within 24 hours of adding this course. If you miss the deadline you may be dropped. For help, contact your instructor or email disted@gavilan.edu.

HISTORY

HIST 1 United States History through Reconstruction

Transferable: CSU, UC; CSU-GE:C2, D6, IGETC:3B, 4F, 7B; GAV-GE:C2, D2; CAN:HIST8, HIST SEQ B

History of the United States from the time before European contact with the Americas through Reconstruction. Emphasis will be placed on distinctive patterns of political, economic, social, intellectual, and geographic developments within their global context. At the conclusion of the course, the student should understand major themes in the history of the United States, and be able to explain various ways in which ideas about federal vs. state power, ethnicity, class, and gender divisions have influenced the nation's development. This course has the option of a letter grade or pass/no pass. ADVISORY: Eligible for English 250 and English 260.

10012 Lec SS214 Halper L 3.2 3.0 TR 0945-1105

10013 Lec MHG12 Mosher C 3.2 3.0 MW 0945-1105
Above class meets at Morgan Hill Community site.

10014 Lec HOL2 Luna E 3.2 3.0 TR 0945-1105
Above class meets at the Hollister Briggs site.

10011 Lec SS214 Halper L 3.2 3.0 MW 0230-0350

10015 Lec SS214 Halper L 3.3 3.0 R 0600-0905

HIST 2 United States History Reconstruction to the Present

Transferable: CSU, UC; CSU-GE:C2, D6, IGETC:3B, 4F, 7B; GAV-GE:C2, D2; CAN:HIST10, HIST SEQ B

History of the United States from Reconstruction to the present. Emphasis will be placed on distinctive patterns of political, economic, social, intellectual, and geographic developments within their global context. At the conclusion of the course, the student should understand major themes in the history of the United States, and be able to explain various ways in which ideas about federal vs. state power, ethnicity, class, and gender divisions have influenced the nation's development. This course has the option of a letter grade or pass/no pass. ADVISORY: Eligible for English 250 and English 260.

10019 Lec MHG12 Mosher C 3.2 3.0 MW 0810-0930
Above class meets at Morgan Hill Community site.

10023 Lec SS214 Luna E 3.2 3.0 MW 0945-1105

10020 Lec HOL2 Luna E 3.2 3.0 TR 1120-1240
Above class meets at the Hollister Briggs site.

10022 Lec SS214 Kier D 3.2 3.0 TR 1120-1240

10017 Lec HOL2 Luna E 3.3 3.0 T 0600-0905
Above class meets at the Hollister Briggs site.

10018 ONLINE Guardino L 3.0

 You must have an email account to take this course. Start your course by going to www.gavilan.edu/disted. Unless you have made prior arrangements with the instructor, you MUST log on by 11:59 pm on the first day of the semester. Late adds must login within 24 hours of adding this course. If you miss the deadline you may be dropped. For help, contact your instructor or email disted@gavilan.edu.

Day of Beauty

for Men & Women

Includes:

- ✓ Hair cut & style
- ✓ Deep conditioning
- ✓ Scalp treatment
- ✓ Manicure
- ✓ Facial
- ✓ Eyebrow arch
- ✓ Makeup

no substitutions

only **\$30**
w/o coupon - \$35



DISCOUNTS

Senior Citizens: 20% daily

Staff/Students: 10% daily

Discounts not applicable to DAILY SPECIALS, Special perms or any service under \$6.00

Spring/Fall hours

Wed.-Fri. 10:00 am - 2:30 pm

Summer hours

Tu.-Th. 10:30 am - 3:30 pm

DAILY SPECIALS

Wednesday:

Hair Cut ONLY - \$5.50

Hair Cut & Style - \$10

Thursday/Friday:

All Basic Perms - 20% off

Plain Manicure & Pedicure - \$11

Wednesday/Friday:

Hair Color - 20% off

All work performed by students supervised by instructors.

Discounts not applicable to daily specials, special color, special perms or any service under \$6. Not valid with any other discounts.

For appointments call 408-842-5055

CRN Type Room Instructor Hrs. Units Days Begin-End

HIST 3 History of California

Transferable: CSU, UC; CSU-GE:C2, D6, IGETC:3B, 4F; GAV-GE:C2, D2, F

A study of California's history from pre-contact with Europeans to the present day. Social, cultural, economic, political and environmental issues will be explored towards an understanding of California's history. ADVISORY: Eligible for English 1A and English 260.

10024 Lec SS110 Halper L 3.2 3.0 MW 1120-1240

This service learning section involves community work. See page 64 for details.

HIST 4B History of World Societies 1500 to Present

Transferable: CSU, UC; CSU-GE:C2, D6, IGETC:3B, 4F; GAV-GE:C2, D2

A study of major elements in the development of and interactions between world societies, from the dawn of the Renaissance to the modern day. Students will comparatively analyze the social, cultural, geographic, economic, demographic, technological, environmental, and political developments that moved humans from the Middle Ages to the modern era. This course has the option of a letter grade or pass/no pass. ADVISORY: English 250 and English 260.

10025 Lec SS205 Mosher C 3.3 3.0 W 0600-0905

HIST 5 Women's Lives in Early United States History

Transferable: CSU, UC; CSU-GE:C2, D4, D6, IGETC:3B, 4F; GAV-GE:C2, D1, D2, F

This survey course begins with pre-contact peoples and extends to the end of the nineteenth century. The class examines the construction of womanhood through United States history, and the effects of gender, ethnicity, class, and sexual orientation upon women's experiences. Students will study the contributions of various individual women and groups of women in creating the modern United States, and will analyze social, political, economic, and cultural forces affecting women to both join and resist movements for social change. Students will also learn to apply contemporary feminist theory to traditional historical approaches. This course has the option of a letter grade or pass/no pass. ADVISORY: Eligible for English 250 and English 260.

10021 Lec SS214 Guardino L 3.3 3.0 F 0810-1115

This service learning section involves community work. See page 64 for details.

CRN Type Room Instructor Hrs. Units Days Begin-End

HIST 7A History of Western Civilization

Transferable: CSU, UC; CSU-GE:C2, IGEC:3B; GAV-GE:C2; CAN:HIST2, HIST SEQ A

A study of major elements in Western heritage from the ancient world to the eighteenth century. Course will survey intellectual, political, social, economic and cultural development of the Western World. ADVISORY: English 250 and English 260.

10030 Lec SS205 Kier D 3.2 3.0 TR 0810-0930

HIST 12 Cultural History of the Mexican American

Transferable: CSU, UC; CSU-GE:C2, D3, D6, IGEC:3B, 4F; GAV-GE:D2, F

The Mexican American experience as influenced by society in the United States. Emphasis will be on the historical and contemporary contributions made by the Indian, Spanish, Mexican, and Mexican American. Emphasis will also be on the social, economic, and political milieu of the Mexican American within the context of the American society. This course has the option of a letter grade or pass/no pass. ADVISORY: Eligible for English 250 and English 260.

10016 Lec SS214 Luna E 3.2 3.0 MW 1250-0210

HIST 21 Ancient Americas: A History through Art

Transferable: CSU, UC; CSU-GE:C1, C2, IGEC:3A; GAV-GE:C2, F

A critical survey of history through the arts of pre-Columbian natives of North, Central and South America. The course will cover major societies and events from the appearance of major civilizations through the initial colonization efforts of European nations. Due to the distinct history of the Americas, this course uses the arts - architecture, sculpture, ceramics and painting, among others - of ancient societies as a primary source material. This course has the option of a letter grade or pass/no pass. This course is also listed as ART 21. ADVISORY: Eligible for English 250.

10481 Lec HOL5 STAFFS 3.2 3.0 MW 0230-0350
Above class meets at the Hollister Briggs site.

HUMANITIES

HUM 3 Introduction to the Cinema

Transferable: CSU, UC; CSU-GE:C2, IGEC:3B; GAV-GE:C2

This course provides an introduction to the cinema. It includes a view of the inventors and the technological developments that led to the modern motion picture; an historical perspective on the growth and development of cinema including significant films that contributed to its establishment as an art form, a study of film genres such as the comedy, the musical, and the western; the technology of image and sound; and a look at the basic techniques of filmmakers when they attempt to convey meaning. ADVISORY: Eligible for English 250 and 260.

10237 Lec SS214 Richards G 3.2 3.0 MW 1120-1240

10238 Lec SS214 Richards G 3.2 3.0 TR 1250-0210

HUM 4 Introduction to American Cinema

Transferable: CSU, UC; CSU-GE:C2, IGEC:3B; GAV-GE:C2

This introductory course in film studies is a survey of the American film industry as an art form, as an industry, and as a system of representation and communication. The course explores how Hollywood films work technically, aesthetically, and culturally to reinforce and challenge America's national self-image. ADVISORY: English 440

10239 ONLINE Richards G 3.0

You must have an email account to take this course. Start your course by going to www.gavilan.edu/disted. Unless you have made prior arrangements with the instructor, you MUST log on by 11:59 pm on the first day of the semester. Late adds must login within 24 hours of adding this course. If you miss the deadline you may be dropped. For help, contact your instructor or email disted@gavilan.edu.

HUM 23 Independent Study

Transferable: CSU

Designed to afford selected students specialized opportunities for exploring areas at the independent study level. The courses may involve extensive library work, research in the community, or special projects. May be repeated until six units of credit are accrued. This course has the option of a letter grade or pass/no pass. REQUIRED: The study outline prepared by the student and the instructor must be filed with the department and the dean.

10235 Ind HU111 Richards G 1.0

10236 Ind HU111 Richards G 2.0

CRN Type Room Instructor Hrs. Units Days Begin-End

INDUSTRIAL TECHNOLOGY

IT 115 Industrial Safety

Transferable: CSU

This course is an introduction to the construction industry. It will cover the basic skill sets required to earn an entry-level position in various trades in construction. Students will learn basic math, vocabulary, blue print reading and safety skills along with the soft skills required to gain employment. This course has the option of a letter grade or pass/no pass. ADVISORY: Eligible for English 250 and English 260.

10800 Lec PB4A Wright D 3.3 3.0 R 0600-0905

Information Science: see CSIS

JAPANESE

JPN 1A Elementary Japanese

Transferable: CSU, UC; CSU-GE:C2; GAV-GE:C2

Beginning course with emphasis on understanding and speaking Japanese; introduction to reading and writing Japanese. This course will also introduce students to Japanese culture and institutions. This course has the option of a letter grade or pass/no pass.

10643 L/L SS111 Sakai T 5.4 5.0 MW 0230-0455
ARR TBA 2.0

JOURNALISM

JOUR 10 Mass Media and Society

Transferable: CSU, UC; CSU-GE:C2, D0, IGEC:4J; GAV-GE:C2, D2; CAN:JOUR4

This course helps students understand the 20th century revolution in mass media by focusing on the history, economics and social impact of the newspaper, book publishing, magazine, film, television, public relations, advertising and music industries. Students will study audience, propaganda and mass communication theory; and discuss new technology, ethnic media in the United States, ethical issues and attempts to regulate or control the media. Honors students will complete more in-depth analysis of media issues and will finish a media-related research project. This course is also listed as SOC 10. This course has the option of a letter grade or pass/no pass. ADVISORY: English 250, English 260.

10051 Lec SS205 Janes J 3.2 3.0 MW 0810-0930

JOUR 16A Writing for Media

Transferable: CSU; GAV-GE:C1; CAN:JOUR2

Fundamentals of journalistic writing and analysis of news values and news writing. Stresses organization and structure of news stories; the language and style of news writing; the basic lead and story types for print and broadcast media. ADVISORY: Typing skill; English 1A eligibility.

10599 Lec HU106 Foley J 3.2 3.0 MW 0810-0930

JOUR 18A Working on the Newspaper

Transferable: CSU; GAV-GE:C1

Students interview, write, photograph and do computer assisted design and graphics for the college newspaper, The Gavilan Press. In doing this, they provide the community with an important first amendment forum, learn and educate about the first amendment rights and responsibilities, and acquire journalistic skills, ethics, and habits. ADVISORY: Eligible for English 1A. Typing ability.

10605 Lab HU106 Janes J 2.6 2.0 MW 0230-0335

10613 Lab HU106 Janes J 5.4 3.0 MW 0230-0455

10614 Lab HU106 Janes J 5.4 4.0 MW 0230-0455
ARR TBA 3.3

10615 Lab HU106 Janes J 5.4 5.0 MW 0230-0455
ARR TBA 6.6

CRN Type Room Instructor Hrs. Units Days Begin-End

JOUR 18B Working on the Newspaper

Transferable: CSU; GAV-GE:C1

Students interview, write, photograph and do computer assisted design and graphics for the college newspaper, The Gavilan Press. In doing this, they provide the community with an important first amendment forum, learn and educate about the first amendment rights and responsibilities and acquire journalistic skills, ethics and habits. ADVISORY: Journalism 18A.

10616	Lab	HU106	Janes J	2.6	2.0	MW	0230-0335
10617	Lab	HU106	Janes J	5.4	3.0	MW	0230-0455
10619	Lab ARR	HU106	Janes J TBA	5.4 3.3	4.0	MW	0230-0455
10621	Lab ARR	HU106	Janes J TBA	5.4 6.6	5.0	MW	0230-0455

JOUR 18C Working on the Newspaper

Transferable: CSU; GAV-GE:C1

Students interview, write, photograph and do computer assisted design and graphics for the college newspaper, The Gavilan Press. In doing this, they provide the community with an important first amendment forum, learn and educate about the first amendment rights and responsibilities and acquire journalistic skills, ethics and habits. ADVISORY: Journalism 18B.

10623	Lab	HU106	Janes J	2.6	2.0	MW	0230-0335
10625	Lab	HU106	Janes J	5.4	3.0	MW	0230-0455
10626	Lab ARR	HU106	Janes J TBA	5.4 3.3	4.0	MW	0230-0455
10628	Lab ARR	HU106	Janes J TBA	5.4 6.6	5.0	MW	0230-0455

JOUR 18D Working on the Newspaper

Transferable: CSU; GAV-GE:C1

Students interview, write, photograph and do computer assisted design and graphics for the college newspaper, The Gavilan Press. In doing this, they provide the community with an important first amendment forum, learn and educate about the first amendment rights and responsibilities and acquire journalistic skills, ethics and habits. ADVISORY: Journalism 18C.

10632	Lab	HU106	Janes J	2.6	2.0	MW	0230-0335
10633	Lab	HU106	Janes J	5.4	3.0	MW	0230-0455
10634	Lab ARR	HU106	Janes J TBA	5.4 3.3	4.0	MW	0230-0455
10635	Lab ARR	HU106	Janes J TBA	5.4 6.6	5.0	MW	0230-0455

JOUR 22 Field Work and Service

Transferable: CSU; GAV-GE:C1

Supervised field work within the college and with local agencies. Students serve in useful group activities in leadership roles prescribed for them by faculty or community agencies. A maximum of six units may be completed. This is a pass/no pass course. REQUIRED: Learning contracts must be filled out and signed by the student and the supervising instructor.

10640	Fld Ex	HU106	Janes J		.5		
-------	--------	-------	---------	--	----	--	--

JOUR 23 Independent Study

Transferable: CSU; GAV-GE:C1

Designed to afford selected students specialized opportunities for exploring areas at the independent study level. The courses may involve extensive library work, research in the community, or special projects. May be repeated until six units of credit are accrued. This course has the option of a letter grade or pass/no pass. REQUIRED: The study outline prepared by the student and the instructor must be filed with the department and the dean.

10642	Ind	HU106	Janes J		2.0		
-------	-----	-------	---------	--	-----	--	--

Sign up early!



Looking for work in the construction fields?

IT 115 Industrial Safety

Thursday evenings, 6:00 -9:05 pm
CRN 10800

Learn:

- ⇒ Entry level math
- ⇒ field related vocabulary
- ⇒ safety skills

To take this class for Gavilan credit, register in person or online.

For information about ROP noncredit registration call 408-848-4816.

Make Something Happen!

Learn Something New!



- ◆ Work in print and online
- ◆ Earn units toward a Media Arts Degree
- ◆ Learn new writing, research and design skills
- ◆ Get published and build a portfolio of your work
- ◆ Gain work experience that will help you land a good job
- ◆ Become part of a team
- ◆ Support free speech at Gavilan College!

JOUR 10 Mass Media & Society

What impact do mass media have on our society and on our world?

JOUR 18A-D Working on the Newspaper

Become a staff member of The Gavilan Press, Gavilan's independent student newspaper, in print and online!

The Final Word!

Look for the Final Exams schedule on page 133 of this schedule.

CRN Type Room Instructor Hrs. Units Days Begin-End

JOUR 190 Occupational Work Experience/Journalism

Transferable: CSU

The application of learned theory, knowledge, and skills to a practical job setting related to the student's educational/occupational goal. Employment must be directly related to the student's college educational/occupational goal. Periodic interviews of the students and employers or their representatives will be required. Each student shall be assisted in the development of individualized performance objectives, toward which the learning experience shall be directed. REQUIRED: Enrollment in a minimum of seven (7) units, including Cooperative Work Experience, during regular semesters; enrollment in at least one other class in summer session.

Mandatory course orientation for the following classed will be conducted Tuesday October 6, 2009 from 530 pm-630 pm the North/South Lounge, Wednesday, October 7, 2009 from 430 pm -530 pm in the North/South Lounge and Thursday October 8, 2009 from 8 am to 9 am in the North/South Lounge. Students need to attend one of the three meetings. Please contact Susan Sweeney, CWVE Coordinator at (408) 848-4813 for more information.

10864	Wrk Ex	LI101A	Sweeney S	1.0
10865	Wrk Ex	LI101A	Sweeney S	2.0
10973	Wrk Ex	LI101A	Sweeney S	3.0
10974	Wrk Ex	LI101A	Sweeney S	4.0

JPA Fire 10865 Wrk Ex LI101A Sweeney S 2.0

Technology
and

JPA Law Enforcement
see ad below:



Careers in

Law Enforcement • Fire Technology

Probation Officer • Dispatcher

Corrections Officer • Juvenile Hall Counselor

Gavilan College is a member of the South Bay Regional Public Safety Training consortium. This consortium is funded by all colleges regionally to provide vocational specific training which may require special facilities, special training conditions or is presented outside of the schedules of regular college classes. For more information call 408-270-6458.

Law Enforcement: see also Administration of Justice

LIBRARY

LIB 3 Research Skills

Transferable: CSU

Research and evaluation skills using the Internet and other electronic resources, as well as traditional printed materials. Also listed as CSIS 3. This course has the option of a letter grade or pass/no pass. May be repeated once for credit. ADVISORY: Eligible for English 250 and 260.

10806	ONLINE	Meador S	2.0
-------	--------	----------	-----

10/14/09 - 12/08/09 You must have an email account to take this course. Start your course by going to www.gavilan.edu/disted. Unless you have made prior arrangements with the instructor, you MUST log on by 11:59 pm on the first day of class. Late adds must login within 24 hours of adding this course. If you miss the deadline you may be dropped. For help, contact your instructor or email disted@gavilan.edu.

Don't be confused!
There are new codes
to designate days

R means Thursday!
U means Sunday!

CRN Type Room Instructor Hrs. Units Days Begin-End

LIB 6 Web Page Authoring I

Transferable: CSU; GAV-GE:E2

A introduction to using Hypertext Mark-Up Language (HTML) and Extensible HTML (XHTML) to create web pages which can be uploaded and displayed on the World Wide Web. Students will use HTML/XHTML to create web pages with text in various sizes and colors, links to other sites, background color or patterns, graphics, tables, and mailto links. Principles of design and color as they apply to screen presentations will be included. This course has the option a letter grade or pass/no pass. May be repeated three times for credit. Also listed as CSIS 6 and DM 6. ADVISORY: CSIS 1 or CSIS 2 or CSIS/LIB 3 advised.

10313	ONLINE	Howell J	2.0
-------	--------	----------	-----

09/03/09 - 10/26/09 You must have an email account to take this course. Start your course by going to www.gavilan.edu/disted. Unless you have made prior arrangements with the instructor, you MUST log on by 11:59 pm on the first day of class. Late adds must login within 24 hours of adding this course. If you miss the deadline you may be dropped. For help, contact your instructor or email disted@gavilan.edu.

10317	ONLINE	Howell J	2.0
-------	--------	----------	-----

10/19/09 - 12/12/09 You must have an email account to take this course. Start your course by going to www.gavilan.edu/disted. Unless you have made prior arrangements with the instructor, you MUST log on by 11:59 pm on the first day of class. Late adds must login within 24 hours of adding this course. If you miss the deadline you may be dropped. For help, contact your instructor or email disted@gavilan.edu.

MANAGEMENT

MGMT 102 Retail Management

Transferable: CSU

Principles and practices used in management of retail businesses such as foods, motels, service stations, and direct channels. Includes site selection, layout, organization, staffing, positioning, customer service, promotional techniques, and all aspects of the critical buying function. This course has the option of a letter grade or pass/no pass. ADVISORY: Eligible for English 250 and English 260.

10893	Lec	HOL4	Kurtz S	3.3	3.0	W	0600-0905
-------	-----	------	---------	-----	-----	---	-----------

Above class meets at the Hollister Briggs site.

MARKETING

MKTG 100 Principles of Marketing

Transferable: CSU

An introduction to the economic and social problems involved with moving goods and services from the producer to the consumer. This course covers topics such as marketing institutions, channels of distribution, pricing, and government relationships. This course has the option of a letter grade or pass/no pass. ADVISORY: Eligible for English 250 and English 260.

10949	Lec	MHG4	Taylor J	3.3	3.0	U	0400-0705
-------	-----	------	----------	-----	-----	---	-----------

Above class meets at Morgan Hill Community site.

MASS COMMUNICATIONS & TELEVISION

see also JOURNALISM



MCTV 16 Television History and Practice

Transferable: CSU, UC

This course examines theories, history and development of television technology and current distribution practices. Programming genres and production techniques are analyzed, evaluated and compared with other societies as tools of mass communication. This course is also listed as THEA 16. ADVISORY: Eligible for English 250 and 260.

10953	Lec	LI140	Abad M	3.2	3.0	MW	1120-1240
-------	-----	-------	--------	-----	-----	----	-----------



MCTV 17A Television and Video Workshop

Transferable: CSU, UC

An introduction to television and video technology, including pre-production, production and post-production techniques such as: camera work, studio equipment, lighting, audio plus off-line and on-line editing. This course is also listed as THEA 17A. ADVISORY: Theatre Arts 16 Intro to TV or consent of instructor.

10954	L/L	LI140	Frazier J	5.4	3.0	TR	1250-0315
-------	-----	-------	-----------	-----	-----	----	-----------

Classroom Locations: Refer to "How to Use This Schedule" on page 5.

CRN Type Room Instructor Hrs. Units Days Begin-End



MCTV 17B Television and Video Workshop

Transferable: CSU, UC

Emphasis placed on production and post-production techniques in video production. Student knowledge and skills are increased by participating in live to tape projects. May be repeated twice for credit. This course is also listed as THEA 17B. ADVISORY: Completion of Theatre Arts 17A.

10955 Lec LI140 Frazier J 5.4 3.0 TR 1250-0315



MCTV 19 Television and Film Acting

Transferable: CSU, UC

Theory and practice of acting for film and television. Students will learn basic performance techniques for the camera. Learning experiences include projects in broadcasting, reporting, commercials, public service announcements (psa), comedy and drama. This course has the option of a letter grade or pass/no pass. May be repeated three times for credit. This course is also listed as THEA 19.

10956 L/L LI140 STAFFS 3.2 3.0 TR 1120-1240

MATHEMATICS

MATH 1A Single-Variable Calculus and Analytic Geometry

Transferable: CSU, UC; CSU-GE:B4, IGETC:2A; GAV-GE:B4; CAN:MATH18, MATH SEQ BC

Limits and continuity, analyzing the behavior and graphs of functions, derivatives, implicit differentiation, higher order derivatives, related rates and optimization word problems, Newton's Method, Fundamental Theorem of Calculus, and definite and indefinite integrals. PREREQUISITE: Mathematics 10 or Mathematics 8B with a grade of 'C' or better.

10364 Lec SS206 Wagman K 4.8 4.0 MWF 1250-0210

MATH 1B Single-Variable Calculus and Analytic Geometry

Transferable: CSU, UC; CSU-GE:B4, IGETC:2A; GAV-GE:B4; CAN:MATH20, MATH SEQ BC

This course is a standard second semester Calculus course covering methods of integration, applications of the integral, differential equations, parametric and polar equations, and sequences and series. PREREQUISITE: Mathematics 1A with a grade of 'C' or better.

10365 Lec PH102 Dachkova E 4.6 4.0 TR 0600-0805

MATH 5 Introduction to Statistics

Transferable: CSU, UC; CSU-GE:B4, IGETC:2A; GAV-GE:B4; CAN:STAT2

Descriptive analysis and presentation of either single-variable data or bivariate data, probability, probability distributions, normal probability distributions, sample variability, statistical inferences involving one and two populations, analysis of variance, linear correlation and regression analysis. Statistical computer software will be extensively integrated as a tool in the description and analysis of data. PREREQUISITE: Mathematics 233 with a grade of 'C' or better. The instructor will be using and supporting a TI-83 Plus graphing calculator in all classroom demonstrations.

10432 L/L PH103 Dwyer M 3.2 3.0 TR 1120-1240
L/L PH101 Dwyer M 1.6 F 1120-1210

10431 L/L PH103 Jukl H 2.3 3.0 M 0230-0435
L/L PH103 Jukl H 1.3 W 0230-0335
L/L PH101 Jukl H 1.0 W 0345-0435

10433 L/L CH102 Littig A 4.6 3.0 TR 0600-0805

10434 L/L MHG13 Viarengo A 2.3 3.0 M 0600-0805
L/L MHG8 Viarengo A 2.3 W 0600-0805
Above class meets at Morgan Hill Community site.

10435 ONLINE Haussermann J 3.0



You must have an email account to take this course. Start your course by going to www.gavilan.edu/disted. Unless you have made prior arrangements with the instructor, you MUST log on by 11:59 pm on the first day of the semester. Late adds must login within 24 hours of adding this course. If you miss the deadline you may be dropped. For help, contact your instructor or email disted@gavilan.edu.

Be Aware

You MAY NOT take courses that overlap (courses that meet at the same day and time)

NEW PROGRAM

Retail Management Certificate Coming Soon! (pending approval)



The certificate is composed of ten courses which may be offered in a combination of face to face and distance learning formats. Future courses include:



- Principles of Marketing
- Introduction to Supervision
- Management Techniques
- Human Resources Management
- Leadership/Human Relations in Business

MKTG 100 - Principles of Marketing is the first course in the certificate.

CRN 10949 Sunday 4-7:05 pm in Morgan Hill

Contact the office of Technical and Public Services at 408-848-4719 for additional information.



FREE TUTORING!

Services for Gavilan Students:

Free Tutoring for MATH
Free Computer Assistance

For daily schedule or for free Math downloads, check our website - <http://www.gavilan.edu/math/mathlab/index.html/>

Staffed by the Math Department

CRN Type Room Instructor Hrs. Units Days Begin-End

MATH 7 Finite Mathematics

Transferable: CSU, UC; CSU-GE:B4, IGETC:2A; GAV-GE:B4; CAN:MATH12

Systems of linear equations and matrices, introduction to linear programming, finance, counting techniques and probability, properties of probability and applications of probability. PREREQUISITE: Mathematics 233 with a grade of 'C' or better.

10436 Lec LS102 Lockhart L 3.2 3.0 TR 0810-0930

MATH 8A First Half of Precalculus

Transferable: CSU, UC; CSU-GE:B4, IGETC:2A; GAV-GE:B4

Math 8A prepares the student for the study of calculus by providing important skills in algebraic manipulation, interpretation, and problem solving at the college level. Topics will include basic algebraic concepts, complex numbers, equations and inequalities of the first and second degree, functions, and graphs, linear and quadratic equations, polynomial functions, exponential and logarithmic functions, systems of equations, matrices and determinants, right triangle trigonometry, and the Law of Sines and Cosines. PREREQUISITE: Mathematics 233 with a grade of 'C' or better. The instructor will be using and supporting TI-83 Plus graphing calculator in all classroom demonstrations.

10437 Lec SS206 Nari J 4.2 4.0 TRF 0945-1055

10438 Lec PH103 Lee R 4.2 4.0 MWF 1250-0200

CRN Type Room Instructor Hrs. Units Days Begin-End

MATH 8B Second Half of Precalculus

Transferable: CSU, UC; CSU-GE:B4, IGETC:2A; GAV-GE:B4

Math 8B prepares students for the study of calculus by providing important skills in algebraic manipulation, interpretation, and problem solving at the college level. Topics will include trigonometric functions, identities, inverse trigonometric functions, and equations; applications of trigonometry, vectors, complex numbers, polar and parametric equations; conic sections; sequences, series, counting principles, permutations, mathematical induction; analytic geometry, and an introduction to limits. PREREQUISITE: Mathematics 8A with a grade of 'C' or better. ADVISORY: Math 208 Survey of Practical Geometry.

10439	Lec	CH102	Maisch F	4.6	4.0	MW	0600-0805
-------	-----	-------	----------	-----	-----	----	-----------

MATH 12 Mathematics for Elementary Teachers

Transferable: CSU, UC; CSU-GE:B4; GAV-GE:B4

This course is intended for students preparing for a career in elementary school teaching. Emphasis will be on the structure of the real number system, numeration systems, elementary number theory, and problem solving techniques. Technology will be integrated throughout the course. PREREQUISITE: High School Geometry and Math 233 (Intermediate Algebra), or, Math 208 (Plane Geometry) and Math 233 (Intermediate Algebra). All courses must be completed with a grade of 'C' or better.

10363	Lec	MHG10	Kercheval S	3.3	3.0	M	0630-0935
Above class meets at Morgan Hill Community site.							

MATH 201B Math for Science and Engineering

Transferable: No

This course will provide a combination of math study skills, introduction to scientific equipment and technology for mathematics, collection and analysis of data from various branches of science, one or more field trips, investigation of science careers and program choices at the transfer level. COREQUISITE: Enrollment in appropriate section of Math 233 which is part of a learning community.

10366	Lec	SS206	Dresch M	1.0	1.0	F	1120-1210
This class is part of a Learning Community. If you enroll in this class you must also enroll in Math 233, CRN #10400.							

MATH 205 Elementary Algebra

Transferable: No; GAV-GE:B4

This course is a standard beginning algebra course, including algebraic expressions, linear equations and inequalities in one variable, graphing, equations and inequalities in two variables, integer exponents, polynomials, rational expressions and equations, radicals and rational exponents, and quadratic equations. Mathematics 205, 205A and 205B, and 206 have similar course content. This course may not be taken by students who have completed Mathematics 205B or 206 with a grade of "C" or better. This course may be taken for Mathematics 205B credit (2.5 units) by those students who have successfully completed Mathematics 205A with a grade of "C" or better. PREREQUISITE: MATH 402 with a grade of 'C' or better or assessment test recommendation.

10367	Lec	PH103	Knight R	5.0	5.0	MTWRF	0810-0905
10369	Lec	PH103	Dresch M	5.2	5.0	MTWR	0945-1050

↳ continued

CRN Type Room Instructor Hrs. Units Days Begin-End

10372	Lec	CH105	Wagman K	5.2	5.0	MTWR	1120-1225
10379	Lec	LS101	Kim D	2.6	5.0	MW	1250-0155
	Lec	PH103	Kim D	2.6		TR	1250-0155
10370	Lec	CH105	Fassler J	5.2	5.0	MTWR	1250-0155
10371	Lec	HOL5	Knight R	5.2	5.0	MTWR	1250-0155
Above class meets at the Hollister Briggs site.							
10368	Lec	MHG13	Kercheval S	5.2	5.0	MTWR	1250-0155
Above class meets at Morgan Hill Community site.							
10373	Lec	CH105	Ward S	5.2	5.0	MTWR	0410-0515
10374	Lec	HOL4	Bates R	5.4	5.0	TR	0600-0825
Above class meets at the Hollister Briggs site.							
10375	Lec	MHG13	Butterworth Y	5.4	5.0	TR	0600-0825
Above class meets at Morgan Hill Community site.							

MATH 205A First Half of Elementary Algebra

Transferable: No; GAV-GE:B4

This course is the first half of the Elementary Algebra course. It will cover signed numbers, evaluation of expressions, ratios and proportions, solving linear equations, and applications. Graphing of lines, the slope of a line, graphing linear equations, solving systems of equations, basic rules of exponents, and operations on polynomials will be covered. PREREQUISITE: Effective Fall 2005: MATH 402 with a grade of 'C' or better or assessment test recommendation. ADVISORY: Concurrent enrollment in Guidance 563A is advised.

10380	Lec	LS101	Lawson D	4.2	2.5	MWF	0810-0920
10381	Lec	PH102	Lockhart L	4.2	2.5	TRF	1250-0200
10382	Lec	PH102	Buchanan M	9.2	2.5	MTWR	0230-0435
09/01/09 - 10/24/09							
10384	Lec	PH103	Arid A	4.6	2.5	MW	0600-0805

MATH 205B Second Half of Elementary Algebra

Transferable: No; GAV-GE:B4

This course contains the material covered in the second half of the Elementary Algebra Course. It will cover factoring, polynomials, solving quadratic equations by factoring, rational expressions and equations, complex fractions, radicals and radical equations, solving quadratic equations by completing the square and the quadratic formula. Application problems are integrated throughout the topics. PREREQUISITE: Math 205A with a grade of 'C' or better. ADVISORY: Concurrent enrollment in Guidance 563B is advised.

10386	Lec	LS103	Fassler J	4.2	2.5	MWF	1120-1230
10387	Lec	PH102	Buchanan M	9.2	2.5	MTWR	0230-0435
10/26/09 - 12/19/09							

Be Aware
If your goal is a MULTIPLE SUBJECT CREDENTIAL,
you may need MATH 12, Math for Elementary
Teachers.

Close Encounters with Math and Science



- Have you ever wondered how math applies to real world problems?
- Are you looking for a supportive environment to help with your math?
- Have you ever thought about a career in science, engineering or math, but doubted your ability to get through the math class required?
- Would you like to finally understand how to solve word problems?

Then this Learning Community is for you! Sign up for:

MATH 201B Math for Science and Engineering

10366	Lec	SS206	Dresch M	1.0	1.0	F	1120-1210
-------	-----	-------	----------	-----	-----	---	-----------

MATH 233 Intermediate Algebra

10400	Lec	SS206	Dresch M	5.2	5.0	MTWR	1120-1225
-------	-----	-------	----------	-----	-----	------	-----------



For more information about this exciting new program, contact math instructor Marla Dresch in LS112, call (408) 846-4915 or email mdresch@gavilan.edu.

CRN Type Room Instructor Hrs. Units Days Begin-End

MATH 233 Intermediate Algebra

Transferable: No; GAV-GE:B4

Review of basic concepts, linear equations and inequalities, graphs and functions, systems of linear equations, polynomials and polynomial functions, factoring, rational expressions and equations, roots, radicals, and complex numbers, solving quadratic equations, exponential and logarithmic functions, and problem solving strategies. Mathematics 233, 233A, and 233B have similar course content. This course may not be taken by students who have completed Mathematics 233B with a grade of 'C' or better. This course may be taken for Mathematics 233B credit (2.5) units by those students who have successfully completed Mathematics 233A with a grade of 'C' or better. PREREQUISITE: Mathematics 205 or Mathematics 205A and 205B or Mathematics 206 with a grade of 'C' or better. The instructor will be using and supporting TI-83 Plus graphing calculator in all classroom demonstrations.

LEARNING COMMUNITY MATH 233 CLASS:

10400 Lec SS206 Dresch M 5.2 5.0 MTWR 1120-1225
This class is part of a Learning Community. If you enroll in this class you must also enroll in Math 201B, CRN # 10366.

10388 Lec CH102 Lee R 5.0 5.0 MTWRF 0810-0905

10390 Lec SS206 Dwyer M 2.6 5.0 MW 0945-1050
CH105 TR 0945-1050

10392 Lec PH103 Kim D 3.2 5.0 MW 1120-1240
Lec PH103 Kim D 2.0 F 1040-1240

10395 Lec CH102 Nari J 5.2 5.0 MTWR 1250-0155

10389 Lec MHG10 Potter R 5.2 5.0 MTWR 1250-0155
Above class meets at Morgan Hill Community site.

10391 Lec HOL1 Malokas J 5.2 5.0 MTWR 1250-0155
Above class meets at the Hollister Briggs site.

10396 Lec SS206 Grover M 5.2 5.0 MTWR 0410-0515

10397 Lec PH103 Grover M 5.4 5.0 TR 0600-0825

MATH 233A First Half of Intermediate Algebra

Transferable: No

The course will start with a review of basic concepts and then cover the following topics with an emphasis on applications and problem solving strategies: solving linear equations; solving linear, compound, and absolute value inequalities; equations and graphs of lines; functions and function notation including composition of functions; solving systems of linear equations and inequalities; an introduction to matrices and Cramer's rule; operations with polynomials; factoring polynomials; and solving polynomial equations. PREREQUISITE: Completion of Mathematics 205 or the equivalent with a grade of 'C' or better.

10401 Lec CH105 Bass J 4.2 2.5 TRF 0810-0920

10403 Lec CH102 Fuller G 4.2 2.5 MWF 0945-1055

10412 Lec LS101 Wolff L 4.6 2.5 MW 0230-0435
09/01/09 - 10/24/09

10412 Lec CH102 Wolff L 4.6 TR 0230-0435

10410 Lec LS101 Lockhart L 4.6 2.5 TR 0600-0805

MATH 233B Second Half of Intermediate Algebra

Transferable: No

This course will start with a review factoring polynomials, and then cover the following topics with an emphasis on applications and problem solving strategies: solving polynomial equations by factoring; adding, subtracting, multiplying, dividing and simplifying rational expressions and solving rational equations; adding, subtracting, multiplying, dividing and simplifying roots, radicals and complex numbers and solving radical equations; the various methods of solving quadratic equations and inequalities; graphing quadratic functions; and working with exponential and logarithmic functions, equations and expressions. PREREQUISITE: Completion of MATH 233A with a grade of 'C' or better.

10416 Lec LS102 Dachkova E 4.2 2.5 TRF 1120-1230

10414 Lec LS101 Wolff L 4.6 2.5 MW 0230-0435
CH102 Wolff L 4.6 TR 0230-0435

10/26/09 - 12/19/09

**Gavilan College
Overview of Math Courses**

Grade of "C" or better required in order to progress to the next course

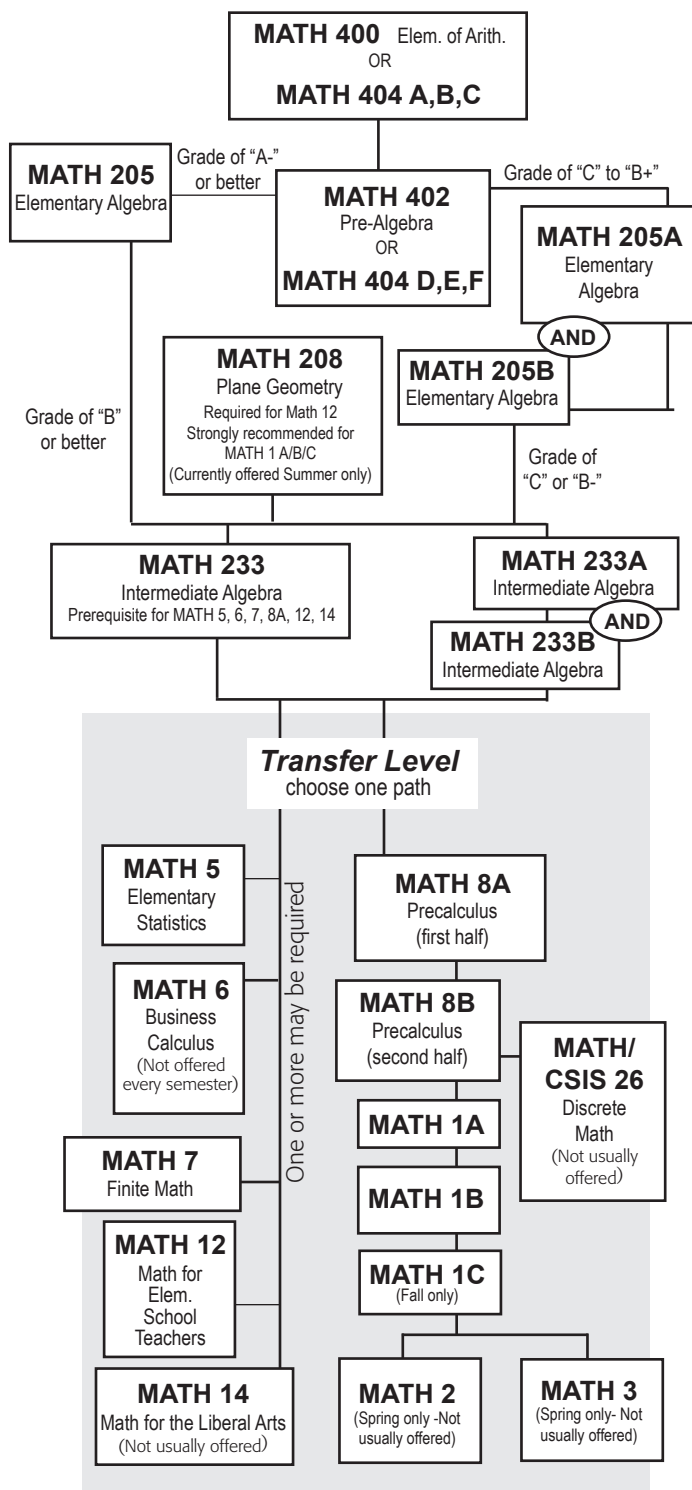

Multiple measures will be considered to determine your final course. Consult with a counselor to select the appropriate course.

Have you met the prerequisite? **It's required!**

CRN Type Room Instructor Hrs. Units Days Begin-End

MATH 400 Elements of Arithmetic

Transferable: No

Essential arithmetic operations, whole numbers, integers, fractions, decimals, ratio, proportion, percent, applications of arithmetic, and critical thinking, as well as math-specific study skills. Units earned in this course do not count toward the associate degree and/or other certain certificate requirements.

10417	L/L	SS206	Fuller G	4.0	3.0	MTWR	0810-0905
10418	L/L	LS103	Potter R	3.2	3.0	MW	0945-1105
	L/L	LS103	Potter R	1.0		F	0945-1035
10419	L/L	SS206	Arid A	4.6	3.0	TR	0600-0805

MATH 402 Pre-Algebra

Transferable: No

This course covers operations with integers, fractions and decimals and associated applications, percentages, ratio, and geometry and measurement, critical thinking and applications. Elementary algebra topics such as variables, expressions, and solving equations are introduced. PREREQUISITE: Completion of Math 400 with a 'C' or better, or assessment test recommendation.

10420	L/L	PH102	STAFF S	4.0	3.0	MTWR	0810-0905
10421	L/L	LS101	Lockhart L	3.2	3.0	TR	1120-1240
	L/L	LS101	Lockhart L	1.0		F	1200-1250
10422	L/L	CH105	Ward S	4.2	3.0	TRF	0230-0340
10423	L/L	PH102	Littig A	4.6	3.0	MW	0600-0805

MATH 404A-G Self-Paced Basic Math

Transferable: No

This course is a remedial, modular, self-paced course. Application and critical thinking skills are developed in each module. Module A covers operations with whole numbers, equivalent fractions, multiplying and dividing fractions. Module B covers adding and subtracting fractions, and operations with decimals. Module C covers ratio and proportion, percent, and units of measurement. Module D reviews fractions, decimals, percentages, and covers operations with integers, and working with variables. Module E covers real numbers, fractions, exponents, scientific notation, and order of operations. Module F covers expressions, polynomials, and equations. Module G covers geometric figures, perimeter and area, surface area and volume, triangles and parallelograms, and similar figures. This course has the option of a letter grade or pass/no pass. This course involves both lecture and hands-on computer assisted software. All sections are open for late registration. Math 404 A-C is the equivalent of Math 400.

These classes involve both lecture and hands-on computer components. All sections are open for late registration.

MATH 404A	10424	L/L	PH101	Dachkova E	5.6	1.0	TR	1250-0320
MATH 404B	10425	L/L	PH101	Dachkova E	5.6	1.0	TR	1250-0320
MATH 404C	10426	L/L	PH101	Dachkova E	5.6	1.0	TR	1250-0320
MATH 404D	10427	L/L	PH101	Dachkova E	5.6	1.0	TR	1250-0320
MATH 404E	10428	L/L	PH101	Dachkova E	5.6	1.0	TR	1250-0320
MATH 404F	10429	L/L	PH101	Dachkova E	5.6	1.0	TR	1250-0320
MATH 404G	10430	L/L	PH101	Dachkova E	5.6	1.0	TR	1250-0320

Medical Terminology: see Business

Don't forget

A counselor's signature is required if you take over 17.99 units (spring/fall) or over 5.99 units (summer).

You do not need a counselor's signature to register for a class with a prerequisite that was successfully completed at Gavilan.

CRN Type Room Instructor Hrs. Units Days Begin-End

MUSIC

MUS 1A Music History and Literature

Transferable: CSU, UC; CSU-GE:C1; IGETC:3A; GAV-GE:C1; CAN:MUS8

A survey of the development of music in western civilization including representative composers from the Medieval to the present. Music 1A will study the music and styles from the Medieval to the Romantic period. ADVISORY: Eligible for English 250 and English 260.

10677	Lec	AL101	Juncker A	3.2	3.0	TR	0810-0930
-------	-----	-------	-----------	-----	-----	----	-----------

MUS 3A Harmony - Theory - Musicianship

Transferable: CSU, UC; CSU-GE:C1; GAV-GE:C1

Fundamentals of music, beginning harmony. ADVISORY: Must be taken in sequence.

10690	L/L	AL101	Juncker A	4.6	4.0	MW	1120-0125
-------	-----	-------	-----------	-----	-----	----	-----------

MUS 3B Harmony - Theory - Musicianship

Transferable: CSU, UC; GAV-GE:C1

Fundamentals of music, beginning harmony. ADVISORY: Must be taken in sequence.

10691	L/L	AL101	Juncker A	4.6	4.0	MW	1120-0125
-------	-----	-------	-----------	-----	-----	----	-----------

MUS 4A Beginning Piano

Transferable: CSU, UC; CSU-GE:C1; GAV-GE:C1

Introduction to music fundamentals and keyboard technique. Development of beginning keyboard skills including note reading in bass and treble clef, fingering, rhythm, key signatures, primary chords and inversions. ADVISORY: Must be taken in sequence.

10692	L/L	AL102	Amirkhanian M	4.6	3.0	MW	0900-1105
10693	L/L	AL102	Amirkhanian M	4.6	3.0	TR	0900-1105
10695	L/L	AL102	Amirkhanian M	3.2	3.0	MW	1120-1240
10694	L/L	AL102	Mello S	4.3	3.0	M	0530-0935

MUS 4B Beginning Piano

Transferable: CSU, UC; GAV-GE:C1

Continuation of Music 4A. ADVISORY: Music 4A

10696	L/L	AL102	Amirkhanian M	3.2	2.0	TR	1120-1240
10697	L/L	AL102	Mello S	4.3	2.0	M	0530-0935

MUS 5A Intermediate Piano

Transferable: CSU, UC; GAV-GE:C1

Development of intermediate keyboard skills through means of scales, chords, and technical studies. Continuation of music fundamentals and beginning keyboard harmony; introduction of easier classical and standard piano literature. ADVISORY: Music 4B

10698	L/L	AL108	Amirkhanian M	3.2	2.0	TR	1120-1240
10699	L/L	AL102	Mello S	4.3	2.0	M	0530-0935

MUS 5B Intermediate Piano

Transferable: CSU, UC; GAV-GE:C1

Development of intermediate keyboard skills through means of scales, chords and technical studies. Continuation of music fundamentals and beginning keyboard harmony; introduction of easier classical and standard piano literature. ADVISORY: Music 5A

10700	L/L	AL102	Amirkhanian M	3.2	2.0	TR	1120-1240
10701	L/L	AL102	Mello S	4.3	2.0	M	0530-0935

MUS 5C Advanced Piano

Transferable: CSU, UC; GAV-GE:C1

Development of advanced keyboard skills through means of scales, chords and technical studies. Continuation of music fundamentals and keyboard harmony; introduction of moderately difficult classical and standard piano literature. ADVISORY: Music 5B

10702	L/L	AL102	Amirkhanian M	3.2	2.0	TR	1120-1240
10703	L/L	AL102	Mello S	4.3	2.0	M	0530-0935

Classroom Locations: Refer to "How to Use This Schedule" on page 5.