

Choose a **THEME** for your English class:

Find the number, by the course section number, that corresponds to a theme below.



- 1 Explore American consumerism and wild alternatives.
- 2 Explore the great American classics.
- 3 Explore how literature can both forge new entry points and maintain existing boundaries between individuals and communities. Focus on images of race, ethnicity, gender and sexuality in classic plays, American poetry and modern fiction.
- 4 Explore the great literature of the human condition, challenging you to respond to literary art, science fiction, music, tragedy and the joy of life and living.
- 5 Explore a little basic science and technology on the way to becoming a competent, college-level writer.

- 6 Investigate environmental issues, particularly those connected to what we eat and where we live.
- 7 Delve into Chicano/Latino literature.
- 8 Delve into the theme of overcoming hardships.
- 9 Enjoy reading and writing the personal journey.
- 10 Enjoy reading and writing the hero.
- 11 Puente: Focus on Mexican American/Latino literature.
- 12 Learn to be a skeptic, ask questions, take nothing for granted and have the courage of your convictions. Not for those convinced that all life's answers lie in the paranormal and supernatural.
- 13 Explore issues of war and coming of age.
- 14 Investigate urgent social issues through contemporary literature.
- 15 Take a different look at the wars we all think we know, through the literature and personal accounts of writers such as John Steinbeck, Eve Ensler and Lousi DeBernais.

ENGLISH

ENGL 1A Composition

Transferable: CSU, UC; CSU-GE:A2; IGETC:1A; GAV-GE:A2; CAN:ENGL2, ENGL SEQ A

This is a writing course which emphasizes expository writing, argumentative writing, and critical reading of expository prose. It is meant to train students in clear thinking and reasoned support of ideas. Students will be given the opportunity to read models of good expository and argumentative prose and learn the techniques of good writing. These include choosing appropriate subjects, developing restricted, unified, and precise theses and presenting supporting evidence in a logical, lucid, and effective manner. To achieve this end, students write no fewer than six essays and read at least five works, two of which are book length. **PREREQUISITE:** English 250 and English 260 or English 250 and SSCI 270A or English 250 and SSCI 270B with a grade of 'C' or better or satisfactory score on the English placement examination.

Tutorial help is offered for ENGL 1A classes. See your instructor.

10042	Lec	SS203	Pirani A	3.20	3.0	MW	0810A-0930A
10043	Lec	MHG3	McMillen J	3.20	3.0	TR	0810A-0930A
Above class meets at Morgan Hill Community site.							
10046	Lec	SS203	Mora G	3.20	3.0	MW	0945A-1105A
10047	Lec	PB14	Condon D	3.20	3.0	TR	0945A-1105A
10048	Lec	SS203	Jackson S	3.30	3.0	F	0945A-1250P
10050	Lec	HOL6	Mora G	3.20	3.0	MW	0230P-0350P
Above class meets at the Hollister Briggs site.							
10051	Lec	PB14	Salvin C	3.20	3.0	MW	1120A-1240P
10052	Lec	SS203	Jackson S	3.20	3.0	TR	1250P-0210P
10053	Lec	SS203	Draegan K	3.20	3.0	MW	0230P-0350P
10055	Online N/A		Wisdom K		3.0		

This online class will be delivered entirely over the Internet. After enrolling, start the class by going to <http://www.gavilan.edu/disted>, and log into the system. Students who have not logged in by 5 pm on the 3rd day may be dropped from the class.

This online class will be delivered entirely over the Internet. After enrolling, start the class by going to <http://www.gavilan.edu/disted>, and log into the system. Students who have not logged in by 5 pm on the 3rd day may be dropped from the class.

This HYBRID lecture/online class will be delivered partially over the Internet. See the online syllabus for details. <http://www.gavilan.edu/disted/>

This HYBRID lecture/online class will be delivered partially over the Internet. See the online syllabus for details. <http://www.gavilan.edu/disted/>

10054 Lec PB14 Jackson S 3.20 3.0 TR 0400P-0520P

2 10057 Lec MHG10 Luoma D 3.30 3.0 T 0600P-0905P
Above class meets at Morgan Hill Community site.

5 10060 Lec HOL1 Brett T 3.30 3.0 W 0600P-0905P
Above class meets at the Hollister Briggs site.

10066 Lec SS203 Pirani A 3.30 3.0 R 0600P-0905P

2 10076 Lec PB14 Luoma D 3.30 3.0 M 0600P-0905P

ENGL 1B Composition and Literature

Transferable: CSU, UC; CSU-GE:C; IGETC:3B; GAV-GE:C2; CAN:ENGL4, ENGL SEQ A

English 1B continues the work begun in 1A, but now the emphasis shifts to writing expository prose in conjunction with reading and analyzing imaginative literature. Students are to write as fledgling critics and use the text as a basis for other forms of reflection. The reading requirement includes short stories, poetry, drama, and at least two novels. Course work will also include fundamentals of research writing. **PREREQUISITE:** English 1A with a grade of "C" or better.

Tutorial help is offered for ENGL 1B classes. See your instructor.

10077 Online N/A Wisdom K 3.0
 This online class will be delivered entirely over the Internet. After enrolling, start the class by going to <http://www.gavilan.edu/disted>, and log into the system. Students who have not logged in by 5 pm on the 3rd day may be dropped from the class. Tutorial help is offered for this class. See your instructor.

10079 Online N/A Warren K 3.0
 This online class will be delivered entirely over the Internet. After enrolling, start the class by going to <http://www.gavilan.edu/disted>, and log into the system. Students who have not logged in by 5 pm on the 3rd day may be dropped from the class. Tutorial help is offered for this class. See your instructor.

3 10083 Lec PB3 Smith K 3.20 3.0 TR 0945A-1105A

10084 Lec PB14 Osikomaiya J 3.30 3.0 F 1100A-0205P

10085 Lec SS203 Crook E 3.20 3.0 MW 1120A-1240P

14 10091 Lec HOL4 Salvin C 3.20 3.0 TR 1120A-1240P
Above class meets at the Hollister Briggs site.

3 10086 Lec PB14 Smith K 3.20 3.0 TR 1250P-0210P

15 10087 Lec PB14 Oral M 3.20 3.0 MW 0230P-0350P

4 10089 Lec SS203 Brett T 3.30 3.0 T 0600P-0905P

ENGL 1C Critical Reasoning and Writing

Transferable: CSU, UC; CSU-GE:A3; IGETC:1B; GAV-GE:C2

This course is designed to develop critical thinking, reading, and writing skills beyond the level achieved in English 1A. The emphasis is on critical analysis of arguments and the development of the ability to integrate the principles of critical thinking into essay writing. **PREREQUISITE:** English 1A with a grade of "C" or better.

Tutorial help is offered for ENGL 1C classes. See your instructor.

10092 Online N/A Candelaria X 3.0
 This online class will be delivered entirely over the Internet. After enrolling, start the class by going to <http://www.gavilan.edu/disted>, and log into the system. Students who have not logged in by 5 pm on the 3rd day may be dropped from the class. Tutorial help is offered for this class. See your instructor.

10097 Lec LS106 Condon D 3.20 3.0 TR 0810A-0930A

10099 Lec MHG11 Luoma D 3.20 3.0 MW 1120A-1240P
Above class meets at Morgan Hill Community site.

10101 Lec PB3 Candelaria X 3.20 3.0 TR 0400P-0520P

12 10104 Lec SS110 Brett T 3.30 3.0 M 0600P-0905P

CRN	Type	Room	Instructor	Hrs.	Units	Days	Begin-End
-----	------	------	------------	------	-------	------	-----------

ENGL 2B Introduction to Multi-Cultural Literature

Transferable: CSU, UC; CSU-GE:C2; IGETC:3B; GAV-GE:C2, F

Students will examine the concept of ethnicity in the context of contemporary American multi-ethnic literature: Native American, Hispanic American, Black American, Asian American. Students will critique this literature using the accepted elements of literary criticism. They will read and analyze selections from each literature and explain their results in journals, oral presentations, a research project and examinations. PREREQUISITE: Eligible for English 1A.

10109	Lec	SS216	Warren K	3.20	3.0	TR	1120A-1240P
-------	-----	-------	----------	------	-----	----	-------------

ENGL 2C Introduction to Film and Fiction

Transferable: CSU, UC; CSU-GE:C2; IGETC:3B; GAV-GE:C2

This is a literature course in analysis of the novel and film as art forms. The student will read several novels, view the films based on the novels, and discuss the difference in techniques, both orally and in writing. PREREQUISITE: Eligible for English 1A.

10106	Lec	SS214	Richards G	3.30	3.0	W	0630P-0935P
-------	-----	-------	------------	------	-----	---	-------------

ENGL 4A British Literature - 449 to 1798 A.D.

Transferable: CSU, UC; CSU-GE:C2; IGETC:3B; GAV-GE:C2; CAN:ENGL8, ENGL SEQ B

This course is a study of the masters of British literature. In English 4A the student studies the years 449 through 1798 A.D. PREREQUISITE: Eligible for English 1A.

10111	Lec	PH102	Sandler S	3.20	3.0	MW	1120A-1240P
-------	-----	-------	-----------	------	-----	----	-------------

ENGL 9A Introduction to Creative Writing

Transferable: CSU, UC; CSU-GE:C2; GAV-GE:C2; CAN:ENGL6

This course includes the writing, reading, and critical discussions of various forms of poetry and fiction. PREREQUISITE: Eligible for English 1A.

10113	Lec	SS216	Tice R	3.20	3.0	MW	1250P-0210P
-------	-----	-------	--------	------	-----	----	-------------

10140	Lec	PB14	Candelaria X	3.30	3.0	W	0530P-0835P
-------	-----	------	--------------	------	-----	---	-------------

ENGL 9B Advanced Creative Writing

Transferable: CSU, UC; CSU-GE:C2; GAV-GE:C2

This class is a continuation of English 9A, with the emphasis shifting to publication. The genre of non-fiction will be the primary focus, but the genres of fiction will also be taught at a more comprehensive level than in English 9A. The process of finding a market for one's work will be followed step by step. The class may compile and publish "Soaring", Gavilan's literary magazine, each spring semester. PREREQUISITE: English 9A with a grade of credit or C or better.

10115	Lec	SS216	Tice R	3.20	3.0	MW	1250P-0210P
-------	-----	-------	--------	------	-----	----	-------------

10141	Lec	PB14	Candelaria X	3.30	3.0	W	0530P-0835P
-------	-----	------	--------------	------	-----	---	-------------

ENGL 9C Poetry Writing

Transferable: CSU, UC; CSU-GE:C2; GAV-GE:C2

This course includes the writing, reading, and critical discussions of various forms of poetry. PREREQUISITE: English 9A with a grade of credit or C or better.

10116	Lec	SS216	Tice R	3.20	3.0	MW	1250P-0210P
-------	-----	-------	--------	------	-----	----	-------------

10142	Lec	PB14	Candelaria X	3.30	3.0	W	0530P-0835P
-------	-----	------	--------------	------	-----	---	-------------

Don't forget

A counselor's signature is required if you take over 17.99 units (spring/fall) or over 5.99 units (summer).

You do not need a counselor's signature to register for a class with a prerequisite that was successfully completed at Gavilan.

Have you met the prerequisite?
It's required!

CRN	Type	Room	Instructor	Hrs.	Units	Days	Begin-End
-----	------	------	------------	------	-------	------	-----------

ENGL 12A Tutoring Writers: Training/Theory & Practice

Transferable: CSU

Fundamentals of compositional theory, the writing process, peer-to-peer communication, interacting with faculty and educational institutions and effective responses to writing will be covered. In addition, students will gain an understanding of the basic history, methodology and practice of writing pedagogy while developing a writing community that aids in connecting them to their own writing practice. ADVISORY: Eligible for English 1A.

Required. Students enrolling in CRNs below must attend an intensive week-long seminar the week prior to the start of fall semester:

08/25/07 - 08/28/07	LI120	SMITH K		MTWR	0930A-0230P
---------------------	-------	---------	--	------	-------------

10143	Lec	LI120	Smith K	2.30	1.0	M	0230P-0435P
-------	-----	-------	---------	------	-----	---	-------------

10144	Lec	LI120	Smith K	2.30	2.0	M	0230P-0435P
-------	-----	-------	---------	------	-----	---	-------------

10145	Lec	LI120	Smith K	2.30	3.0	M	0230P-0435P
-------	-----	-------	---------	------	-----	---	-------------

ENGL 12B Tutoring Writers: Training/Theory & Practice

Transferable: CSU

Fundamentals of compositional theory, the writing process, peer-to-peer communication, interacting with faculty and educational institutions and effective responses to writing will be covered. In addition, students will gain an understanding of the basic history, methodology and practice of writing pedagogy while developing a writing community that aids in connecting them to their own writing practice. ADVISORY: Eligible for English 1A.

Required. Students enrolling in CRNs below must attend an intensive week-long seminar the week prior to the start of fall semester:

08/25/07 - 08/28/07	LI120	SMITH K		MTWR	0930A-0230P
---------------------	-------	---------	--	------	-------------

10146	Lec	LI120	Smith K	2.30	1.0	M	0230P-0435P
-------	-----	-------	---------	------	-----	---	-------------

10148	Lec	LI120	Smith K	2.30	2.0	M	0230P-0435P
-------	-----	-------	---------	------	-----	---	-------------

10150	Lec	LI120	Smith K	2.30	3.0	M	0230P-0435P
-------	-----	-------	---------	------	-----	---	-------------

ENGL 12C Tutoring Writers: Training/Theory & Practice

Transferable: CSU

Fundamentals of compositional theory, the writing process, peer-to-peer communication, interacting with faculty and educational institutions and effective responses to writing will be covered. In addition, students will gain an understanding of the basic history, methodology and practice of writing pedagogy while developing a writing community that aids in connecting them to their own writing practice. ADVISORY: Eligible for English 1A.

Required. Students enrolling in CRNs below must attend an intensive week-long seminar the week prior to the start of fall semester:

08/25/07 - 08/28/07	LI120	SMITH K		MTWR	0930A-0230P
---------------------	-------	---------	--	------	-------------

10151	Lec	LI120	Smith K	2.30	1.0	M	0230P-0435P
-------	-----	-------	---------	------	-----	---	-------------

10153	Lec	LI120	Smith K	2.30	2.0	M	0230P-0435P
-------	-----	-------	---------	------	-----	---	-------------

10155	Lec	LI120	Smith K	2.30	3.0	M	0230P-0435P
-------	-----	-------	---------	------	-----	---	-------------

ENGL 12D Tutoring Writers: Training, Theory & Practice

Transferable: CSU

Fundamentals of compositional theory, the writing process, peer-to-peer communication, interacting with faculty and educational institutions and effective responses to writing will be covered. In addition, students will gain an understanding of the basic history, methodology and practice of writing pedagogy while developing a writing community that aids in connecting them to their own writing practice. ADVISORY: Eligible for English 1A.

Required. Students enrolling in CRNs below must attend an intensive week-long seminar the week prior to the start of fall semester:

08/25/07 - 08/28/07	LI120	SMITH K		MTWR	0930A-0230P
---------------------	-------	---------	--	------	-------------

10156	Lec	LI120	Smith K	2.30	1.0	M	0230P-0435P
-------	-----	-------	---------	------	-----	---	-------------

10158	Lec	LI120	Smith K	2.30	2.0	M	0230P-0435P
-------	-----	-------	---------	------	-----	---	-------------

10160	Lec	LI120	Smith K	2.30	3.0	M	0230P-0435P
-------	-----	-------	---------	------	-----	---	-------------

ENGL 23 Independent Study

Transferable: CSU

Designed to afford selected students specialized opportunities for exploring areas at the independent study level. The courses may involve extensive library work, research in the community, or special projects. May be repeated until six units of credit are accrued. This course has the option of a letter grade or pass/no pass. REQUIRED: The study outline prepared by the student and the instructor must be filed with the department and the dean.

10183	Ind	LI119	Smith K		1.0		
-------	-----	-------	---------	--	-----	--	--

10185	Ind	LI119	Smith K		2.0		
-------	-----	-------	---------	--	-----	--	--

10999	Ind	SS109	Warren K		1.0		
-------	-----	-------	----------	--	-----	--	--

CRN Type Room Instructor Hrs. Units Days Beg: -End

ENGL 250 Practical Writing

Transferable: No; GAV-GE:A2

This course covers writing clear, correct, effective essays and learning preliminary research skills. PREREQUISITE: English 440 or ESL 563 with a grade of 'C' or better or satisfactory score on the English placement examination.

CRN	Type	Room	Instructor	Hrs.	Units	Days	Beg: -End
10186	Lec	PB14	Sandler S	3.20	3.0	MW	0810A-0930A If you enroll in this class you must enroll in CRN 10187 or 10188. This service learning course section involves community work
10187	Lab	LI120	Sandler S	1.00		T	0810A-0900A If you enroll in this class you must enroll in CRN 10186.
10188	Lab	LI120	Sandler S	1.00		R	0810A-0900A If you enroll in this class you must enroll in CRN 10186.
10199	Lec	PB14	Osikomaiya J	3.20	3.0	TR	0810A-0930A If you enroll in this class you must enroll in CRN 10201 or 10202.
10201	Lab	LI171	Osikomaiya J	1.00		F	0810A-0900A If you enroll in this class you must enroll in CRN 10199.
10202	Lab	LI171	Osikomaiya J	1.00		F	0910A-1000A If you enroll in this class you must enroll in CRN 10199.
10374	Lec	MHG11	McMillen J	3.20	3.0	TR	0945A-1105A Above class meets at Morgan Hill Community site. If you enroll in this class you must enroll in CRN 10375 or 10376.
10375	Lab	MHG11	McMillen J	1.00		T	1115A-1205P Above class meets at Morgan Hill Community site. If you enroll in this class you must enroll in CRN 10374.
10376	Lab	MHG11	McMillen J	1.00		R	1115A-1205P Above class meets at Morgan Hill Community site. If you enroll in this class you must enroll in CRN 10374.
10378	Lec	PB14	Salvin C	3.20	3.0	MW	0945A-1105A If you enroll in this class you must enroll in CRN 10379 or 10380.
10379	Lab	LI120	Salvin C	1.00		M	0845A-0935A If you enroll in this class you must enroll in CRN 10378.
10380	Lab	LI120	Salvin C	1.00		W	0845A-0935A If you enroll in this class you must enroll in CRN 10378.
10382	Lec	HOL6	Salvin C	1.60	3.0	T	0945A-1105A
		HOL3	Salvin C	1.60		R	0945A-1105A
							Above class meets at the Hollister Briggs site. If you enroll in this class you must enroll in CRN 10383 or 10386.
10383	Lab	HOL2	Salvin C	1.00		T	0845A-0935A If you enroll in this class you must enroll in CRN 10382.
10386	Lab	HOL2	Salvin C	1.00		R	0845A-0935A If you enroll in this class you must enroll in CRN 10382.
10389	Lec	SS203	Richards G	3.20	3.0	TR	0945A-1105A If you enroll in this class you must enroll in CRN 10390 or 10392.
10390	Lab	LI120	Richards G	1.00		T	1120A-1210P If you enroll in this class you must enroll in CRN 10389.
10392	Lab	LI120	Richards G	1.00		R	1120A-1210P If you enroll in this class you must enroll in CRN 10389.
10397	Lec	PB14	Oral M	3.20	3.0	MW	1250P-0210P If you enroll in this class you must enroll in CRN 10398 or 10399.
10398	Lab	LI171	Oral M	1.00		F	1210P-0100P If you enroll in this class you must enroll in CRN 10397.
10399	Lab	LI171	Oral M	1.00		F	0110P-0200P If you enroll in this class you must enroll in CRN 10397.
10404	Lec	PB3	Candelaria X	3.20	3.0	TR	0230P-0350P If you enroll in this class you must enroll in CRN 10405 or 10406.
10405	Lab	LI120	Candelaria X	1.00		T	0130P-0220P If you enroll in this class you must enroll in CRN 10404.
10406	Lab	LI120	Candelaria X	1.00		R	0130P-0220P If you enroll in this class you must enroll in CRN 10404.

1 2 3 Your ENGL 250 class has a theme. See list on page 77.

continued

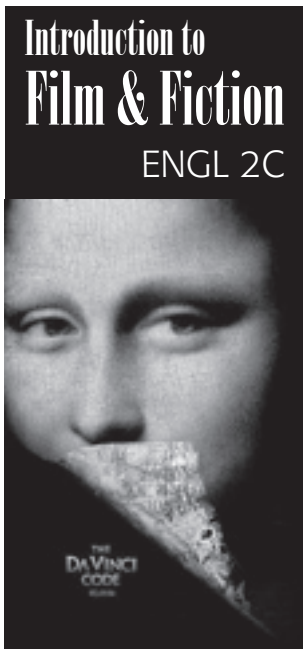

CRN # 10106
Wednesday
6:30 pm - 9:35 pm
Instructor - Grant Richards

- The DaVinci Code*
- Pride and Prejudice*
- Million Dollar Baby*
- Mystic River*
- A History of Violence*
- Cold Mountain*
- Sideways*
- Motorcycle Diaries*
- Closer*
- Fight Club*
- Notebook*
- High Fidelity*
- The Shawshank Redemption*
- To Kill a Mockingbird*
- One Flew Over the Cuckoo's Nest*
- Chocolat*
- LA Confidential*
- Get Shorty*
and more!

This class can fulfill your IGETC humanities transfer requirement.

Introduction to Multi-Cultural Literature

Explore our multicultural history, culture, and society through literature.

- Mexican American
- Asian American
- African American
- Native American
- Short stories, novels, poetry plays and film

3 units
Transfer: CSU/UC

ENGL 2B



CRN # 10109
TuTh 11:20 am - 12:40 pm
Instructor: Karen Warren



This class can fulfill your IGETC humanities transfer requirement.

ENGL 4A

British Literature 499 to 1798 A.D.

CRN # 10111
MW 11:20 pm - 12:40 pm
Instructor: Scott Sandler

CRN Type Room Instructor Hrs. Units Days Begin-End

ENGL 250 Practical Writing *continued from previous page...*

10400	Lec	SS203	Draegan K	3.20	3.0	MW	0400P-0520P
If you enroll in this class you must enroll in CRN 10401 or 10402.							
10401	Lab	LI120	Draegan K	1.00		M	0530P-0620P
If you enroll in this class you must enroll in CRN 10400.							
10402	Lab	LI120	Draegan K	1.00		W	0530P-0620P
If you enroll in this class you must enroll in CRN 10400.							
10407	Lec	SS203	Gardner L	3.20	3.0	MW	0600P-0720P
If you enroll in this class you must enroll in CRN 10408 or 10410.							
10408	Lab	SS203	Gardner L	1.00		M	0730P-0820P
If you enroll in this class you must enroll in CRN 10407.							
10410	Lab	SS203	Gardner L	1.00		W	0730P-0820P
If you enroll in this class you must enroll in CRN 10407.							
10449	Lec	MHG13	Gardner L	3.20	3.0	TR	0700P-0820P
Above class meets at Morgan Hill Community site. If you enroll in this class you must enroll in CRN 10450 or 10451.							
10450	Lab	MHG13	Gardner L	1.00		T	0830P-0920P
Above class meets at Morgan Hill Community site. If you enroll in this class you must enroll in CRN 10449.							
10451	Lab	MHG13	Gardner L	1.00		R	0830P-0920P
Above class meets at Morgan Hill Community site. If you enroll in this class you must enroll in CRN 10449.							

continued

Have you met the prerequisite?
It's required!

ENGLISH COMPOSITION AND READING COURSE SEQUENCE

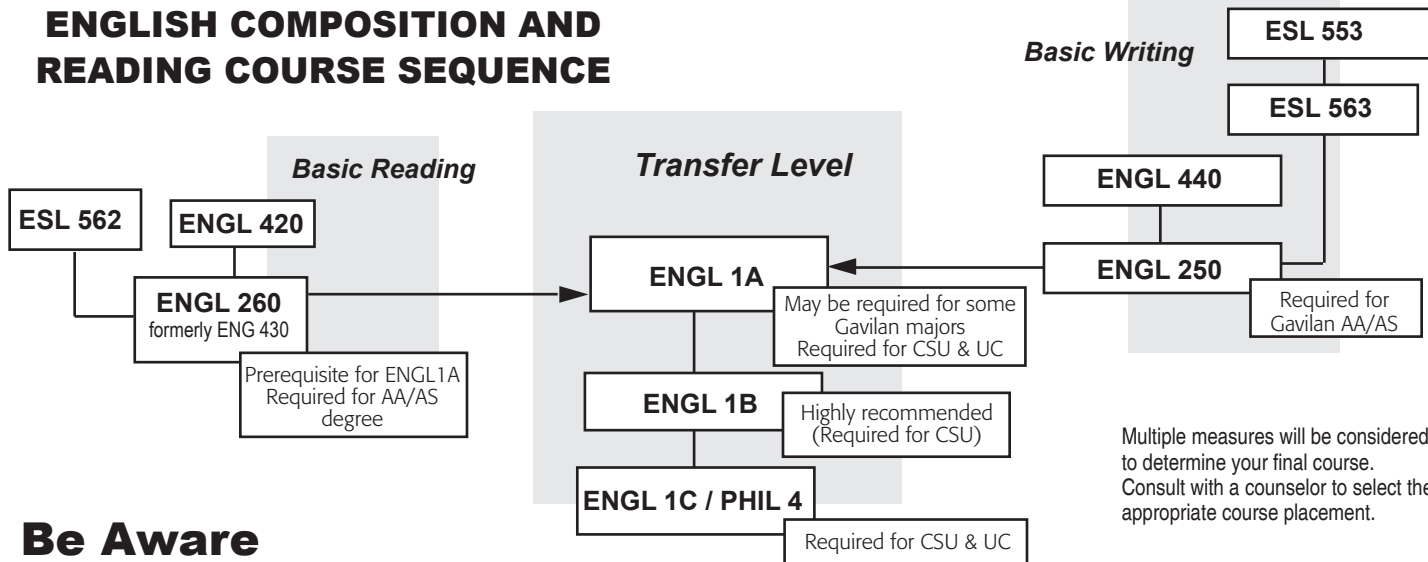

Be Aware

You MAY NOT take courses that overlap (courses that meet at the same day and time)!

Beginning with the summer and fall 2008 enrollment period social security numbers will no longer be used as student identifiers. Find your new Gavilan Student ID and choose a log-on PIN by going to www.gavilan.edu and clicking on the Self-Service Banner icon. You will use your new ID and PIN to log into Self-Service Banner and register for summer and fall classes.

Need a Book Loan?

With an ASB card you can apply for an ASB book loan (up to \$300) at the Financial Aid Office, room SC124. Buy an ASB card at the Admissions & Records Office, room SC111.



CRN Type Room Instructor Hrs. Units Days Begin-End

FIRST YEAR EXPERIENCE ENGL 250 CLASSES See ad on page 83.

10946	Lec	PB3	Warren K	3.20	3.0	MW	0945A-1105A
If you enroll in this class you must enroll in CRN 10947 or 10948. This class is part of a First Year Experience learning community. You must enroll in ENGL 260: CRN 10949.							
10947	Lab	LI120	Warren K	1.00		T	0945A-1035A
If you enroll in this class you must enroll in CRN 10946.							
10948	Lab	LI120	Warren K	1.00		R	0945A-1035A
If you enroll in this class you must enroll in CRN 10946.							
10942	Lec	PB3	Warren K	3.20	3.0	MW	1120A-1240P
If you enroll in this class you must enroll in CRN 10943 or CRN 10944. This class is part of a First Year Experience learning community. You must also enroll in ENGL 260, CRN 10945.							
10943	Lab	LI120	Warren K	1.00		M	0110P-0200P
If you enroll in this class you must enroll in CRN 10942.							
10944	Lab	LI120	Warren K	1.00		W	0110P-0200P
If you enroll in this class you must enroll in CRN 10942.							

PUENTE LEARNING COMMUNITY CLASS

10393	Lec	SS203	Sandler S	3.20	3.0	TR	1120A-1240P
Students enrolling in this class will participate in the PUENTE Program. Students must attend a mandatory Puente Welcome on Monday, August 25, 2008, 8:30 am - 1:00 pm in SS206. REQUIRED: Complete an application with the Puente Counselor prior to registration. This class is part of a learning community. Students must also enroll in GUID 6, CRN 10952 plus an English lab (either CRN 10395 or 10396).							
10395	Lab	LI171	Sandler S	1.00		T	1255P-0145P
If you enroll in this class you must enroll in CRN 10393.							
10396	Lab	LI171	Sandler S	1.00		R	1255P-0145P
If you enroll in this class you must enroll in CRN 10393.							

CRN Type Room Instructor Hrs. Units Days Begin-End

ENGL 260 Preparation for College Reading

Transferable: No; GAV-GE:A3

This is a course presenting strategies in the technique and practice of college level critical reading and thinking skills. PREREQUISITE: Completion of English 420 or ESL 562 with a grade of 'C' or better or Assessment recommendation.

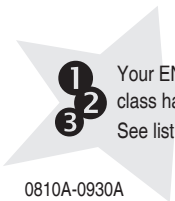

Your ENGL 260 class has a theme. See list on page 77.

10950	Lec	SS203	Hirasuna S	3.20	3.0	TR	0810A-0930A
10951	Lec	HOL1	Hull K	3.30	3.0	F	0900A-1205P Above class meets at the Hollister Briggs site.
10454	Lec	CH101	Hooper J	3.20	3.0	MW	0945A-1105A
10456	Lec	SS206	Candelaria X	3.20	3.0	TR	1120A-1240P
10455	Lec	PB3	Hooper J	3.20	3.0	MW	1250P-0210P
10457	Lec	MHG13	Francis M	3.20	3.0	TR	0530P-0650P Above class meets at Morgan Hill Community site.

FIRST YEAR EXPERIENCE ENGL 260 CLASSES See ad on page 83.

10945	Lec	PB3	Hull K	3.20	3.0	MW	1120A-1240P This class is part of a First Year Experience learning community. If you enroll in this class you must also enroll in ENGL 250: CRN 10942.
10949	Lec	PB3	Hull K	3.20	3.0	MW	0945A-1105A This class is part of a First Year Experience Learning community. If you enroll in this class you must enroll in ENGL 250: CRN 10946.

ENGL 420 Reading Improvement

Transferable: No

This is a practical, "how to" course teaching various methods of learning and reading college material. Using group and individual instruction in vocabulary, comprehension, and study skills, the students will increase their ability to survive academically, to profit, grow and succeed in all college courses, and to enjoy reading and learning. Units earned in this course do not count toward the associate degree and/or certain certificate requirements. PREREQUISITE: Satisfactory score on the English placement examination.

10458	Lec	SS111	Tracey I	3.20	3.0	MW	0810A-0930A If you enroll in this class you must enroll in CRN 10459 or 10461.
10459	Lab	SS110	Tracey I	1.00		F	0810A-0900A If you enroll in this class you must enroll in CRN 10458.
10461	Lab	SS110	Tracey I	1.00		F	0910A-1000A If you enroll in this class you must enroll in CRN 10458.
10468	Lec	SS111	Raimondo J	3.20	3.0	TR	1250P-0210P If you enroll in this class you must enroll in CRN 10469 or 10471.
10469	Lab	LI171	Raimondo J	1.00		T	1150A-1240P If you enroll in this class you must enroll in CRN 10468.
10471	Lab	LI171	Raimondo J	1.00		R	1150A-1240P If you enroll in this class you must enroll in CRN 10468.
10472	L/L	HOL6	Parker V	4.60	3.0	TR	0530P-0735P Above class meets at the Hollister Briggs site.

FIRST YEAR EXPERIENCE ENGL 420 CLASSES Depending on which two Lec/Lab CRNs you take, you will be required to also take two specific Lec/Lab ENGL 440 CRNs. See ad on page 82.

10462	Lec	PB3	Hooper J	3.60	3.0	TR	1250P-0210P If you enroll in this class you must enroll in CRN 10463 or 10464.
10463	Lab	SS216	Hooper J	1.00		T	0230P-0320P If you enroll in this class you must enroll in CRN 10462.
10464	Lab	SS216	Hooper J	1.00		R	0230P-0320P If you enroll in this class you must enroll in CRN 10462.
10465	Lec	PH102	Hooper J	3.20	3.0	TR	1120A-1240P If you enroll in this class you must enroll in CRN 10466 or 10467.
10466	Lab	SS216	Hooper J	1.00		M	1120A-1210P If you enroll in this class you must enroll in CRN 10465.
10467	Lab	SS216	Hooper J	1.00		W	1120A-1210P If you enroll in this class you must enroll in CRN 10465.

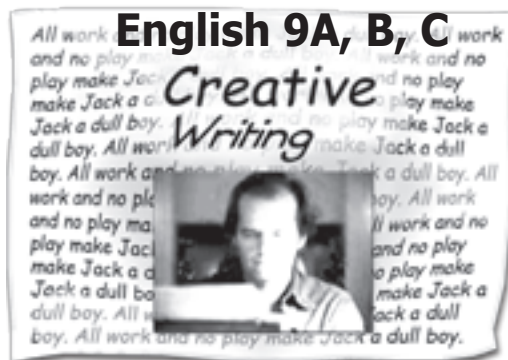

Scene from The Shining

Creative Writing classes allow students to express themselves through writing in a variety of modes: fiction, poetry, drama, and creative non-fiction.

Students will work both individually and in collaborative group activities, as well as respond to each other's work through supportive classroom workshops. Over the course of the semester, students will generate enough material to create a portfolio of their own work.

CRNs 10140, 10141, 10142
Wednesday evening
from 5:30 pm - 8:35 pm
with Xochi Candelaria

CRNs 10113, 10115, 10116
Monday/Wednesday
from 12:50 am - 2:10 pm
with Richard E. Tice

This class fulfills your CSU humanities transfer requirement.

ENGL 749

WRITER'S WORKSHOP

CRN 10968
Tuesday, 2:30 - 4:00 pm
or
CRN 10969
Wednesday, 3:00 - 4:30 pm
Instructor: Kimberly Smith

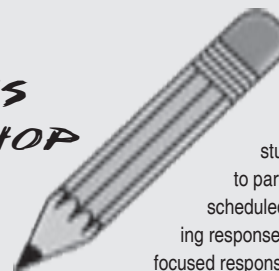

See page 112 for course listing.

Sign up for this open enrollment class that allows community members and students from all disciplines to participate in a regularly scheduled, instructor-facilitated writing response group. Activities include focused response to participants' writing, generative writing games and prompts and interaction with visiting writers and scholars.



The Puente Project combines three components: writing, counseling and mentoring to support students to transfer to four-year universities and colleges. The Guidance 6 course focuses on life skills for higher education and transfer. The English 250 course focuses on Mexican American/Latino literature. The program is open to all eligible students and includes a student leadership conference, university visits and mentor/student socials. For more information, call Celia Marquez, Puente Co-Coordinator at 408-848-4807.

Required: Complete a program application with the Puente Counselor prior to registration. Students must attend a mandatory Puente Welcome on Monday, August 25, 2008, 8:30 am - 1:00 pm in SS206.

ENGL 250	CRN:10393	SS203	SANDLER S	TuTh	1120A-1240P
Choose one lab:					
	CRN: 10395	LI171	SANDLER S	Tu	1255P-0145P
	or CRN: 10396	LI171	SANDLER S	Th	1255P-0145P
GUID 6	CRN: 10952	LS106	MARQUEZ C	W	1120A-0125P
	Additional meeting required on Mondays from 1120 am - 1210 pm in LS106.				

CRN Type Room Instructor Hrs. Units Days Begin-End

ENGL 439 Basic Grammar and Reading

Transferable: No

This is a remediation course introducing basic reading and writing strategies, as well as study skills. Group and individual instruction will be used to build vocabulary, increase reading comprehension, develop study skills, and apply basic grammar to writing. Units earned in this course do not count toward the associate degree and/or certain certificate requirements. This is a pass/no pass course. ADVISORY: Assessment recommendation.

10474	Lec	SS205	Tice R	3.20	4.0	MW	0945A-1105A
	Lab	LI120	Tice R	3.30	4.0	F	0900A-1205P

ENGL 440 Basic Writing

Transferable: No

This is an intensive study and application of basic grammar, sentence, and essay writing skills within the context of composing short essays. Units earned in this course do not count toward the associate degree and/or certain certificate requirements. PREREQUISITE: Satisfactory score on the English placement examination.

8	10476	Lec	SS111	Gatewood J	3.20	3.0	MW	1250P-0210P
		If you enroll in this class you must enroll in CRN 10477 or 10478.						

	10477	Lab	LI120	Gatewood J	1.00		F	1210P-0100P
		If you enroll in this class you must enroll in CRN 10476.						

	10478	Lab	LI120	Gatewood J	1.00		F	0110P-0200P
		If you enroll in this class you must enroll in CRN 10476.						

8	10479	Lec	PH102	Gatewood J	3.20	3.0	MW	0945A-1105A
		If you enroll in this class you must enroll in CRN 10480 or 10481.						

	10480	Lab	LI171	Gatewood J	1.00		F	1010A-1100A
		If you enroll in this class you must enroll in CRN 10479.						

	10481	Lab	LI171	Gatewood J	1.00		F	1110A-1200P
		If you enroll in this class you must enroll in CRN 10479.						

	10489	Lec	SS111	Raimondo J	3.20	3.0	TR	0810A-0930A
		If you enroll in this class you must enroll in CRN 10490 or 10492.						

	10490	Lab	LI171	Raimondo J	1.00		T	1010A-1100A
		If you enroll in this class you must enroll in CRN 10489.						

	10492	Lab	LI171	Raimondo J	1.00		R	1010A-1100A
		If you enroll in this class you must enroll in CRN 10489.						

	10493	Lec	HOL6	Parker V	3.20	3.0	TR	0745P-0905P
		Above class meets at the Hollister Briggs site. If you enroll in this class you must enroll in CRN 10495 or 10495.						

	10494	Lab	HOL6	Parker V	1.00		T	0910P-1000P
		Above class meets at the Hollister Briggs site. If you enroll in this class you must enroll in CRN 10493.						

	10495	Lab	HOL6	Parker V	1.00		R	0910P-1000P
		Above class meets at the Hollister Briggs site. If you enroll in this class you must enroll in CRN 10493.						

9	10496	Lec	SS111	Arora S	3.20	3.0	MW	0530P-0650P
		If you enroll in this class you must enroll in CRN 10498 or 10497.						

	10497	Lab	SS111	Arora S	1.00		M	0700P-0750P
		If you enroll in this class you must enroll in CRN 10496.						

	10498	Lab	SS111	Arora S	1.00		W	0700P-0750P
		If you enroll in this class you must enroll in CRN 10496.						

FIRST YEAR EXPERIENCE ENGL 440 CLASSES Depending on which two Lec/Lab CRNs you take, you will be required to also take two specific Lec/Lab ENGL 420 CRNs. See ad on this page.

10	10482	Lec	PH102	Withers M	3.20	3.0	TR	0945A-1105A
		If you enroll in this class you must enroll in CRN 10483 or 10484.						

	10483	Lab	SS216	Withers M	1.00		R	1250P-0140P
		If you enroll in this class you must enroll in CRN 10482.						

	10484	Lab	SS216	Withers M	1.00		T	1250P-0140P
		If you enroll in this class you must enroll in CRN 10482.						

10	10485	Lec	PB3	Withers M	3.20	3.0	TR	1120A-1240P
		If you enroll in this class you must enroll in CRN 10487 or 10488.						

	10487	Lab	LI120	Withers M	1.00		T	0230P-0320P
		If you enroll in this class you must enroll in CRN 10485.						

	10488	Lab	LI120	Withers M	1.00		R	0230P-0320P
		If you enroll in this class you must enroll in CRN 10485.						



is a program in place in many schools across the country. These programs are in response to much research supporting smaller schools, interdisciplinary studies, and community building. So what is FYE? At Gavilan, this program links fundamental courses together. By studying and working together with your classmates and instructors, you will develop a stronger network of support. Students who enroll in FYE often report higher GPA, increased involvement in school, more friends, greater ability to meet goals, and stronger critical thinking, reading, and writing abilities.

Mark your calendars! This semester we are also offering two Friday First Year Seminars from 1-3:30 on September 26 and October 24.

The following classes are part of a First Year Experience learning community. You must enroll in both courses.

ENGL 420 Reading Improvement

#10462	Lec	PB3	Hooper J	3.60	3.0	TuTh	1250P-0210P
#10463	Lab	SS216	Hooper J	1.00		Tu	0230P-0320P

ENGL 440 Basic Writing

#10485	Lec	PB3	Withers M	3.20	3.0	TuTh	1120A-1240P
#10488	Lab	LI120	Withers M	1.00		Th	0230P-0320P

_____ or _____

ENGL 420 Reading Improvement

#10462	Lec	PB3	Hooper J	3.60	3.0	TuTh	1250P-0210P
#10464	Lab	SS216	Hooper J	1.00		Th	0230P-0320P

ENGL 440 Basic Writing

#10485	Lec	PB3	Withers M	3.20	3.0	TuTh	1120A-1240P
#10487	Lab	LI120	Withers M	1.00		Tu	0230P-0320P

_____ or _____

ENGL 420 Reading Improvement

#10465	Lec	PH102	Hooper J	3.20	3.0	TuTh	1120A-1240P
#10466	Lab	SS216	Hooper J	1.00		M	1120A-1210P

ENGL 440 Basic Writing

#10482	Lec	PH102	Withers M	3.20	3.0	TuTh	0945A-1105A
#10484	Lab	SS216	Withers M	1.00		T	1250P-0140P

_____ or _____

ENGL 420 Reading Improvement

#10465	Lec	PH102	Hooper J	3.20	3.0	TuTh	1120A-1240P
#10467	Lab	SS216	Hooper J	1.00		W	1120A-1210P

ENGL 440 Basic Writing

#10482	Lec	PH102	Withers M	3.20	3.0	TuTh	0945A-1105A
#10483	Lab	SS216	Withers M	1.00		Th	1250P-0140P

Less Grade Stress!!

Many CSIS and BUS classes may be taken for either a letter grade or on a pass/no pass basis. Make your choice when registering or until the NRS deadline (October 3). See Pass/No Pass Grading Option on page 130 for more details.

Classroom Locations: Refer to "How to Use This Schedule" on page 6.



FIRST YEAR EXPERIENCE cont.

Is this your first year at Gavilan? Looking for a community of people like you? Then this learning community program is specially designed for you. The first year of college can be challenging for many students. By studying and working together with your classmates and instructors, in this program you'll develop a strong network of support to help you succeed. You'll improve your reading and writing skills and also explore options for majors, transferring, and careers. Building a strong foundation in your first year will put you on the road to success throughout your college experience.

The Program: Students will take reading and writing together because these skills are needed to succeed in college classes.

The following classes are part of a First Year Experience learning community. You must enroll in both courses.

ENGL 250 Practical Writing

#10942	LEC	PB3	WARREN K	3.20	3.0	MW	1120A-1240P
Choose a lab:							
# 10943	LAB	LI120	WARREN K	1.00		M	0110P-0200P
# 10944	LAB	LI120	WARREN K	1.00		W	0110P-0200P

and

ENGL 260 Preparation for College Reading

10945	Lec	PB3	Hull K	3.20	3.0	MW	1120A-1240P
-------	-----	-----	--------	------	-----	----	-------------

or

ENGL 250 Practical Writing

# 10946	LEC	PB3	WARREN K	3.20	3.0	MW	945A-1105A
Choose a lab:							
# 10947	LAB	LI120	WARREN K	1.00		Tu	0945A-1035A
# 10948	LAB	LI120	WARREN K	1.00		Th	0945A-1035A

and

ENGL 260 Preparation for College Reading

# 10949	LEC	PB3	HULL K	3.20	3.0	MW	945A-1105A
---------	-----	-----	--------	------	-----	----	------------

CRN Type Room Instructor Hrs. Units Days Begin-End

ENGLISH AS A SECOND LANGUAGE

All new ESL students must go through the ESL assessment process. See page 134.

Todos los nuevos estudiantes de ESL deben tomar el examen de nivelación de ESL. Consulte la página 134.

ESL 501 Survival ESL I

Transferable: No

This is a course in survival English for students with little or no oral or written English competency. It will give students basic vocabulary and familiarity in life skill areas such as the family, food, health, and occupations. The course integrates listening, speaking, reading, and writing. (ESL 501, 502, and 503 are sequential courses that may be taken in full form or in halves, preferably A before B.) This is a pass/no pass course. ADVISORY: ESL assessment recommendation

10992	L/L	HOL6	Diehl K	8.40	6.0	MWF	0810A-1040A
	L/L	HOL6	Diehl K	1.60		T	0810A-0930A

Above class meets at the Hollister Briggs site.

ESL 502 Survival ESL II

Transferable: No

This is a second course in survival English for students with little oral or written English competency. It will give students expanded basic vocabulary and familiarity in life skill areas such as the weather, transportation, employment, and American holidays and customs. The course integrates listening, speaking, reading, and writing. (ESL 501, 502, and 503 are sequential courses that may be taken in full form or in halves, preferably A before B.) This is a pass/no pass course. ADVISORY: ESL 501 or ESL 501A and 501B or ESL assessment recommendation

10786	L/L	HOL4	Maxwell K	10.00	6.0	MTWRF	0910A-1105A
-------	-----	------	-----------	-------	-----	-------	-------------

Above class meets at the Hollister Briggs site.

ESL 503 Survival ESL III

Transferable: No

This is a third course in survival English for students with beginning oral or written English competency. It will reinforce basic skills learned and continue to develop vocabulary and ease of communication in life skill areas such as the family, the larger community, health, employment, and leisure activities. The course integrates listening, speaking, reading, and writing. (ESL 501, 502, and 503 are sequential courses that may be taken in full form or in halves, preferably A before B.) This is a pass/no pass course. ADVISORY: ESL 502 or ESL 502A and ESL 502B or ESL assessment recommendation.

10787	L/L	HOL2	Guzman D	10.00	6.0	MTWRF	1115A-0110P
-------	-----	------	----------	-------	-----	-------	-------------

Above class meets at the Hollister Briggs site.

ESL 510A Basic ESL I

Transferable: No

This is an intensive, integrated-skill course for students with little English. Through listening, speaking, reading and writing activities, students learn to use the structures of English with increasing accuracy, while gaining basic life skills. This is a pass/no pass course. ADVISORY: ESL Assessment Recommendation.

10520	L/L	CJ500	Campbell K	9.00	9.0	MTWRF	1000A-1130A
	ARR		TBA	2.00			
10524	L/L	CJ500	Polizzotto J	9.00	9.0	MTWRF	0810A-0940A
	ARR		TBA	2.00			

ESL 510B Basic ESL II

Transferable: No

This course is a continuation of ESL 510A. This is an intensive, integrated-skill program for students who function in a limited way in English. Through listening, speaking, reading and writing activities, students continue learning to use the structures of English with increasing accuracy, while gaining further basic life skills. This is a pass/no pass course. ADVISORY: ESL 510A or ESL assessment recommendation.

10526	L/L	PB12	Baameur K	9.00	9.0	MTWRF	1115A-1245P
	ARR		TBA	2.00			

CRN Type Room Instructor Hrs. Units Days Begin-End

ESL 521 Beginning ESL Listening/Speaking

Transferable: No

This course develops basic listening and speaking skills, moving from a functional survival context to academic readiness. Activities are directed at providing practice through listening exercises, role-play, pair work, small and large group discussion, interviews, and oral presentations. ADVISORY: ESL 510B or ESL Assessment Test Recommendation. Recommended concurrent enrollment in ESL 522 and 523.

10527	L/L ARR	PB13	Wexler L TBA	4.20 2.30	4.0	MWF	0810A-0920A
-------	------------	------	-----------------	--------------	-----	-----	-------------

ESL 522 Beginning ESL Reading/Vocabulary

Transferable: No

This course begins the development of reading skills and vocabulary through the application of different reading strategies to a variety of selections on topics of interest to academically-bound students. ADVISORY: ESL 510B or 510C or Assessment recommendation. Recommended concurrent enrollment in ESL 521 and 523.

10535	L/L ARR	PB13	Cisneros N TBA	3.20 2.40	3.0	TR	0810A-0930A
10785	L/L	PB12	Shelley A	5.60	3.0	TR	0630P-0900P

ESL 523 Beginning ESL Grammar/Writing

Transferable: No

This is a beginning grammar/writing course for students with very basic grammar. The focus is on basic grammatical structures, punctuation and sentence skills. ADVISORY: ESL 510B or ESL Assessment Test recommendation. Recommended concurrent enrollment in ESL 521 and ESL 522.

10536	L/L ARR	PB13	Wexler L TBA	5.20 1.00	5.0	MTWR	1115A-1220P
-------	------------	------	-----------------	--------------	-----	------	-------------

ESL 531 Intermediate ESL Listening/Speaking I

Transferable: No

In this course, listening and speaking skills are developed through extended listening exercises, open-ended dialogues, pair and group discussions, oral interviews, and oral reports. Units earned in this course do not count toward the associate degree and/or certain certificate requirements. ADVISORY: ESL 521 or ESL Assessment Test Recommendation. Recommended concurrent enrollment in ESL 532 and 533.

10773	L/L ARR	PB12	Cisneros N TBA	4.20 2.00	4.0	MWF	0945A-1055A
-------	------------	------	-------------------	--------------	-----	-----	-------------

ESL 532 Intermediate ESL Reading/Vocabulary I

Transferable: No

This course continues the development of reading skills and vocabulary through the application of different reading strategies to a variety of selections on topics of interest to academically-bound students. ADVISORY: ESL 522 or ESL Assessment Recommendation. Recommended concurrent enrollment in ESL 531 and 533.

10774	L/L ARR	PB13	Cisneros N TBA	3.20 2.00	3.0	TR	0945A-1105A
-------	------------	------	-------------------	--------------	-----	----	-------------

ESL 533 Intermediate ESL Grammar/Writing I

Transferable: No

This course involves the practice and refinement of sentence and paragraph skills, structure and punctuation. Students will learn basic use of the computer as a writing tool. Units earned in this course do not count toward the associate degree and/or certain certificate requirements. PREREQUISITE: ESL 523 with a grade of C or better or ESL Assessment Test recommendation. COREQUISITE: Recommended concurrent enrollment in ESL 531 and ESL 532.

10775	L/L ARR	LI100	Lawn B TBA	5.20 1.00	5.0	MTWR	1225P-0130P
-------	------------	-------	---------------	--------------	-----	------	-------------

CRN Type Room Instructor Hrs. Units Days Begin-End

ESL 541 Intermediate ESL Listening/Speaking II

Transferable: No

This course expands listening and speaking skills through extended listening exercises, open-ended dialogues, pair and group discussions, oral interviews, and oral reports. Students broaden vocabulary while listening to and speaking in both formal and informal, conversational and academic situations. ADVISORY: ESL 531 or ESL Assessment Recommendation. Recommended concurrent enrollment in ESL 542 and 543.

10776	L/L ARR	PB13	Sanidad M TBA	4.20 2.00	4.0	MWF	1225P-0135P
-------	------------	------	------------------	--------------	-----	-----	-------------

ESL 542 Intermediate ESL Reading/Vocabulary II

Transferable: No

This course begins the expansion of reading skills and vocabulary development through the application of different reading strategies to a variety of selections on topics of interest to academically-bound students including selections from literature. ADVISORY: ESL 532 or ESL Assessment Recommendation. Recommended concurrent enrollment in ESL 541 and 543.

10777	L/L ARR	LI100	Carrillo L TBA	3.20 2.00	3.0	TR	0810A-0930A
-------	------------	-------	-------------------	--------------	-----	----	-------------

ESL 543 Intermediate ESL Grammar/Writing II

Transferable: No

This course is a continuation of ESL 533. Units earned in this course do not count toward the associate degree and/or certain certificate requirements. PREREQUISITE: ESL 533 with a grade of C or better or ESL assessment recommendation. COREQUISITE: Recommended concurrent enrollment in ESL 541 and ESL 542.

10778	L/L ARR	LI100	Lawn B TBA	5.20 1.00	5.0	TWRF	0945A-1050A
-------	------------	-------	---------------	--------------	-----	------	-------------

ESL 546 Introduction to Computers for ESL Students

Transferable: No

Introduction to basic computer hardware functions and terminology; overview of Windows operating environment and word processing for ESL students. ADVISORY: CSIS 122. Eligible for Gavilan College ESL Program Intermediate.

10784	L/L	BU119	Sanidad M	1.00	1.0	M	1115A-1205P
-------	-----	-------	-----------	------	-----	---	-------------

ESL 552 Advanced ESL Reading/Vocabulary I

Transferable: No

This course focuses on academic and critical thinking skills needed to increase reading comprehension and efficiency. Emphasis is on analyzing, making inferences, taking notes, supporting opinions, summarizing and expanding vocabulary. Readings are from academic texts and literature. ADVISORY: ESL 542 or ESL Assessment Recommendation. Recommended concurrent enrollment in ESL 553 and/or ESL 555.

10779	Lec	PB13	Sanidad M	4.20	4.0	MWF	0945A-1055A
-------	-----	------	-----------	------	-----	-----	-------------

ESL 553 Advanced ESL Composition I

Transferable: No

This course is a composition course for ESL students that develops college composition skills through a review of the parts and elements of the English paragraph and an introduction to the essay form. The course focuses on the development of a paragraph and expands to the writing of multiple paragraphs in an essay. Basic rhetorical patterns and methods of organization are covered using the multiple-draft approach to writing. PREREQUISITE: ESL 543 with a grade of C or better or ESL Assessment Test recommendation. COREQUISITE: Recommended concurrent enrollment in ESL 552 and ESL 554.

10780	L/L ARR	PB12	Campbell K TBA	5.20 1.00	5.0	MTWR	0810A-0915A
-------	------------	------	-------------------	--------------	-----	------	-------------

What is a **CRN**?

CRN stands for Course Reference Number. This is the number (used to be called section) that you will use to register for your classes.

CRN Type Room Instructor Hrs. Units Days Begin-End

ESL 554 Advanced ESL Grammar I

Transferable: No

This course is designed to help students improve their grammar usage so that they will be able to expand their use of grammar structures in oral and written communication. Students begin the study of more sophisticated grammar structures such as past and future perfect, passive voice, and modal auxiliaries for past time, and they review perfect and modals for present and future time. Students will enhance their understanding of grammar by comparing and contrasting new and previously encountered structures and better appreciate the subtleties of English grammar. **PREREQUISITE:** ESL 543 with a grade of 'C' or better or ESL Assessment Test Recommendation. **ADVISORY:** Recommended concurrent enrollment in ESL 552 and ESL 553.

10781	L/L	SS111	Cisneros N	5.20	5.0	TWRF	1115A-1220P
	ARR		TBA	1.00			

ESL 562 Advanced ESL Reading/Vocabulary II

Transferable: No

This course prepares ESL students for mainstream college classes by reviewing a variety of reading skills, strategies, and topics from different academic disciplines. Students expand their academic vocabulary and read short stories or a novel for literary appreciation. **ADVISORY:** ESL 552 or ESL Assessment recommendation. Recommended concurrent enrollment in ESL 563.

10782	Lec	LI100	Lawn B	4.20	4.0	MWF	1105A-1215P
-------	-----	-------	--------	------	-----	-----	-------------

ESL 563 Advanced ESL Composition II

Transferable: No

This course, which is designed for ESL students, refines and further expands college composition skills through the writing of essays using the multiple-draft approach to writing. The course focuses on the structuring and development of an essay with the use of personal examples. Students write in response to a variety of prompts using different rhetorical patterns such as classification, cause/effect, and comparison/contrast. **PREREQUISITE:** ESL 553 with a grade of "C" or better or ESL Assessment Test recommendation. **ADVISORY:** Recommended concurrent enrollment in ESL 562 and ESL 564.

10783	L/L	SS111	Wexler L	5.20	5.0	TWRF	0945A-1050A
	ARR		TBA	1.00			

NEW ESL 585 Editing for ESL Writers

Transferable: No

This course is designed to help second language writers develop self-editing techniques to improve their writing. Students learn to identify and correct grammatical and usage errors in their writing as they become aware of general linguistic rules of English. Students learn to fix, and ultimately avoid, many errors commonly made by second language writers. **ADVISORY:** ESL 554 or ESL Assessment Recommendation.

10995	L/L	LI100	Howell J	3.20	3.0	MW	0810A-0930A
	ARR		TBA	1.00			

Film: see ENGL 2C, HUM 3, 4, 10

Foreign Language: See French (FRNH), Italian (ITAL), Japanese (JPN) and Spanish (SPAN)

FRENCH

FRNH 1A Elementary French

Transferable: CSU, UC; CSU-GE:C2; IGETC:6A; GAV-GE:C2

French 1A is a multi-skilled beginning level class with emphasis on understanding and speaking French. Students are introduced to the cultures and customs of various French-speaking countries.

10634	L/L	HU101	Sanidad M	5.20	5.0	MTWR	0230P-0335P
	ARR			2.8			

*C'est Chic!
Learn French!*



FRNH 1A
Elementary French

CRN 10634
Monday-Thursday
2:30-3:35
Instructor: Mary Ann Sanidad

This course satisfies the general education Humanities (Area C-2) requirement under the AA/AS Degree and the CSU-GE Breadth pattern, and the first half of the language requirement for UC.

**OVERVIEW
of ESL
COURSES**

NON CREDIT	
LIFE SKILLS	VOCATIONAL
ESL 777	ESL 778
ESL 779	ESL 780
ESL 781	ESL 782
VESL ESL 704A/B	
To move from noncredit to credit ESL classes students must take an ESL assessment.	

CREDIT

SURVIVAL TRACK

ACADEMIC TRACK

ESL 501	→	Basic	510A		
ESL 502	→		510B		
ESL 503	→	Beginning	521 L/S	522R	523GW
		Intermediate I	531 L/S	532R	533GW
		Intermediate II	541 L/S	542R	543GW
		Advanced I		552R	553W 554G
		Advanced II	561 L/S	562R	563W 564G

**SUPPLEMENTARY
ESL COURSES:**

- ESL 546 Intro Computers/ESL
- ESL 556 Intro Competency/ESL
- ESL 581 Pronunciation I
- ESL 582 Pronunciation II
- ESL 584 Culture through Film
- ESL 585 Editing for ESL Writers

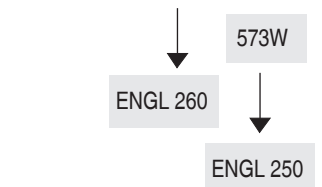

ACADEMIC PROGRAMS or VOCATIONAL PROGRAMS

CRN Type Room Instructor Hrs. Units Days Begin-End

FRNH 23 Independent Study

Transferable: CSU

Designed to afford selected students specialized opportunities for exploring areas at the independent study level. The courses may involve extensive library work, research in the community, or special projects. May be repeated until six units of credit are accrued. This course has the option of a letter grade or pass/no pass. REQUIRED: The study outline prepared by the student and the instructor must be filed with the department and the dean.

10636 Ind SS104 Sanidad M 2.0

GEOGRAPHY

see also CSIS 61 (Geographic Info. Systems)

GEOG 1 Physical Geography

Transferable: CSU, UC; CSU-GE:B3, B1; IGETC:5A; GAV-GE:B1, B3; CAN:GEOG2

An introductory study of the basic physical elements of geography including climate, land forms, soils, water, and natural vegetation. The laboratory will include the tools and methods of geographers. ADVISORY: Eligible for English 250 and English 260.

10216 L/L MHG12 Willahan D 5.40 3.0 TR 0945A-1210P
Above class meets at Morgan Hill Community site.

GEOLOGY

GEOL 1 Introduction to Geology

Transferable: CSU, UC; CSU-GE:B3, B1; IGETC:5A; GAV-GE:B1, B3; CAN:GEOG2

A study of the earth and the physical properties which modify the earth; minerals, rocks, geologic structures and processes. ADVISORY: Eligible for English 250 and English 260.

10797 L/L SS206 Willahan D 6.60 4.0 TR 1250P-0355P

Government: see Political Science
Graphic Arts: see Art, CSIS, Digital Media

GUIDANCE

GUID 1 Self-Assessment and Career Development

Transferable: CSU; CSU-GE:E2; GAV-GE:E2

This course is designed to assist the student in learning more about personal values, personality, interests, exploration of career choice, and occupational opportunities through the use of various personal assessment instruments. The delivery options for this course also include online and self-paced formats. This course is also listed as PSYC 5. ADVISORY: Eligible for English 250 and English 260. \$12 fee will be charged for career assessment materials.

10010 Lec APE120/121 Godley J 2.30 2.0 W 0810A-1015A

10011 Lec HOL 1 Lopez A 2.30 2.0 W 0230P-0435P
Above class meets at the Hollister Briggs site.

10013 Lec SBHS-194 TBA 2.30 2.0 M 0315P-0520P
This class is part of the High Step Program. It will be offered at San Benito High School, room 194. This class is open to all students. For more information, see a Gavilan counselor.

10668 Lec CJ500 Godley J 2.30 2.0 R 1250P-0255P

10661 Online N/A Sharboneau R 2.0
 This online class will be delivered entirely over the Internet. After enrolling, start the class by going to <http://www.gavilan.edu/disted>, and log into the system. Students who have not logged in by 5 pm on the 3rd day may be dropped from the class.

10673 Online N/A Sharboneau R 2.0
 This online class will be delivered entirely over the Internet. After enrolling, start the class by going to <http://www.gavilan.edu/disted>, and log into the system. Students who have not logged in by 5 pm on the 3rd day may be dropped from the class.

CRN Type Room Instructor Hrs. Units Days Begin-End

GUID 6 Life Skills for Higher Education

Transferable: CSU, UC; CSU-GE:E2; GAV-GE:E2

Evaluation and application of academic study methods to achieve subject matter mastery. Development of critical thinking skills, and application of reading, writing, note taking and test taking methods to improve personal strategies. Exploration of personal lifestyle and health factors, including the causes and management of stress, as it relates to academic success. Assessment of academic and career goals, selection of majors, and development of education plans. Topics covered include creative and realistic goal setting, academic and life management, college and community resources, library and Internet use, time management, and techniques to reduce math and science anxiety. This class will address a multitude of cultural learning styles, with emphasis on attaining professional, personal and academic goals in a diverse society. Topics from developmental psychology, learning theory and personality theory. ADVISORY: Eligible for English 250 and English 260.

10016 Lec APE120/121 Tenney L 2.30 2.0 M 0810A-1015A

10952 Lec LS106 Marquez C 2.30 2.0 W 1120A-0125P
Additional weekly meeting required on Mondays from 11:20 am - 12:10 pm in LS106.

Students enrolling in this class will participate in the PUENTE Program. Students must attend a mandatory Puente Welcome on Monday, August 25, 2008, 8:30 am - 1:00 pm in SS206. REQUIRED: Complete an application with the Puente Counselor prior to registration. This class is part of a learning community. Students must also take English 250, CRN 10393 plus an ENGL 250 lab (either CRN 10395 or 10396).

GUID 22 Field Work and Service

Transferable: CSU

Supervised field work within the college and with local agencies. Students serve in useful group activities in leadership roles prescribed for them by faculty or community agencies. A maximum of six units may be completed. This is a pass/no pass course. REQUIRED: Learning contracts must be filled out and signed by the student and the supervising instructor.

10017 Fld Ex LI117 Eastman B 1.0 day/time - see instructor

GUID 28 Tutoring Techniques

Transferable: CSU

This course is designed to train students in effective tutoring skills, introduction to how people learn, teaching to modalities, and techniques of working with student anxiety. This course has the option of a letter grade or pass/no pass. ADVISORY: English 250.

10971 Lec SS111 King D 2.00 1.0 F 1100A-1240P
Lec LI116 King D 4.00 S 0930A-0130P

09/19/08 - 10/31/08 Please contact Debbie King at the Tutoring Center in LI 116 or call (408) 848-4838 upon enrolling in this class. This class meets seven Fridays, Sept. 9 - Oct. 31 and ONLY ONE Saturday, Sept. 27.

GUID 29 Tutoring Lab

Transferable: CSU

This course will allow students to gain valuable experience in the field of teaching. Students will practice the skills they have learned in Guidance 28. Guidance 29 may be repeated for a maximum of 2.0 units per semester and a maximum course total of 8.0 units. This is a pass/no pass course. ADVISORY: Completion of, or concurrent enrollment in Guidance 28.

10954 Lab LI116 King D 1.0 Open entry-open exit.

10955 Lab LI116 King D 2.0 Open entry-open exit.

GUID 250 Supervised Tutoring

Transferable: No

Laboratory class emphasizing college learning skills, appropriate study techniques, and learning assistance utilizing one-on-one or small group tutorial. Guid 250 is a non-credit class and will not appear on a student's transcript.

10002 Lab LI120 TBA Writing Center

10003 Lab LI116 TBA Tutoring Center

10004 Lab LI116 TBA Tutoring Center

10005 Lab LI168 TBA Computer Place

10006 Lab PH101 TBA Math Lab

10007 Lab HOB104 TBA Allied Health

10008 Lab LI126 TBA Digital Media

10009 Lab LI128 TBA Digital Media

CRN Type Room Instructor Hrs. Units Days Begin-End



GUID 251 College Survival Skills

Transferable: No

A course designed to assist students to adjust to the college environment and the learning process. This course will concentrate on the personal and academic skills necessary for educational success. This is a pass/no pass course.

10991 Lec CJ500 TBA 2.30 1.0 M 1250P-0255P
09/29/08 - 11/17/08

GUID 530 Job Readiness

Transferable: No

This course is designed to provide a comprehensive, well-organized approach to assist individuals with the identification of occupational choices and the development of job readiness skills necessary to obtain and maintain employment in a competitive or supported work setting. May be repeated twice for credit. This course has the option of a letter grade or pass/no pass.

10019 L/L APE120/121 Franklin L 3.20 3.0 TR 0945A-1105A

GUID 557 Learning Skills Assessment

Transferable: No

This course provides an assessment of the students' cognitive/perceptual abilities and basic skills academic achievement. The assessment results are used to determine the students' eligibility for Learning Disabilities Services, to develop individual educational plans, and/or to improve the students' understanding of their own learning strengths and weaknesses. The assessment is conducted on a one-to-one basis by appointment. Units earned in this course do not count toward the associate degree and/or certificate requirements. This is a pass/no pass course.

10983 Lab LI117 Overson R .5 day/time - see instructor
Burgman L

Open entry - open exit.

GUID 558 Learning Skills Laboratory

Transferable: No

The Learning Skills Laboratory is designed to assist students who are eligible to receive Learning Disabilities Services and/or have demonstrated academic deficits. The course content is individualized and based on Student Educational Contracts which are developed for each student. Students receive supplemental instruction, academic support, and learning strategy suggestions appropriate for their individual cognitive, perceptual, and academic strengths and weaknesses. Units earned do not count towards the associate degree and/or certificate requirements. This is a pass/no pass course. ADVISORY: Completion of Guidance 557 or demonstrated academic deficit.

The following classes are open entry-open exit

10023 Lab LI116 Overson R/Burgman L .5 day/time - see instructor
10025 Lab LI116 Overson R/Burgman L 1.0 day/time - see instructor
10204 Lab LI116 Overson R/Burgman L 2.0 day/time - see instructor

GUID 561 Writing Skills

Transferable: No

This course is designed to teach basic writing skills to students who have demonstrated difficulty mastering written language and who are eligible to receive Learning Disability Services. Material is presented in a concrete, multi-sensory manner, and the class includes opportunity for immediate practice, repetition, and review. The course content includes grammar, sentence structure, and punctuation. Units earned do not count toward the associate degree and/or certificate requirements. This course has the option of a letter grade or pass/no pass. ADVISORY: Completion of Guidance 557 or demonstrated deficit in written language achievement. Recommended for students with verified learning disability.

10206 L/L BU117 Maringer J 2.00 1.0 MW 1120A-1220P

GUID 562 Directed Study Lab in Arithmetic

Transferable: No

This course is designed for students who have demonstrated difficulty in mastering arithmetic and who are eligible to receive Learning Disability Services. Course content parallels Mathematics 400. Material is presented in a concrete, multi-sensory manner, and the lab allows opportunity for immediate practice, questions, repetition, and review. Units earned do not count toward the associate degree and/or certificate requirements. This is a pass/no pass course. CO-REQUISITE: Concurrent enrollment in MATH 400. ADVISORY: Completion of GUID 557 and/or a demonstrated deficit in arithmetic. Recommended for students with verified learning disability.

10208 Lab BU117 Burgman L 3.20 1.0 TR 1120A-1240P



Service Learning
for community social change

Would you like to raise your grades, connect class material with the real world, and help somebody else as you become culturally competent in your own community? **Try a Service Learning class!** These classes allow you to work at a community non-profit partner agency as part of your coursework, and help you see how academic material applies in your own community!

The following fall 2008 courses at Gavilan will offer Service Learning:

ANTH 3	Intro to Cult Anth	CRN 10213	3 units	MW	230P-350P
ART 14	Beg Mural Painting	CRN 10563	3 units	F	0900A-0105P + 2 arranged hours per week
CMUN 10	Small Group Comm	CRN 10626	3 units	MW	0810A-0930A
		CRN 10627	3 units	TR	0945A-1105A
		CRN 10625	3 units	T	0230P-0535P
ENGL 250	Practical Writing	CRN 10186	3 units	MW	0810A-0930A
HIST 3	Hist of California	CRN 10245	3 units	TR	1250P-0210P
HIST 5	Women's Lives in US History	CRN 10248	3 units	MW	1120A-1240P
POLS 1	Intro to Am Gov	CRN 10272	3 units	TR	0230P-0350P
SOC 1B	Intro to Sociology	CRN 10349	3 units	MW	1250P-0210P
		CRN 10352	3 units	TR	1250P-0210P
THEA 23	Independent Study	CRN 10769	1 unit		
		CRN 10770	2 units		

For Independent Study: The study outline prepared by the student and the instructor must be filed with the department and the dean.



The Puente Project combines three components: writing, counseling and mentoring to support students to transfer to four-year universities and colleges. The Guidance 6 course focuses on life skills for higher education and transfer. The English 250 course focuses on Mexican American/Latino literature. The program is open to all eligible students and includes a student leadership conference, university visits and mentor/student socials. For more information, call Celia Marquez, Puente Co-Coordinator at 408-848-4807.

Required: Complete a program application with the Puente Counselor prior to registration. Students must attend a mandatory Puente Welcome on Monday, August 25, 2008, 8:30 am - 1:00 pm in SS206.

ENGL 250	CRN: 10393	SS203	SANDLER S	TuTh	1120A-1240P
Choose one lab:	CRN: 10395	LI171	SANDLER S	Tu	1255P-0145P
	or CRN: 10396	LI171	SANDLER S	Th	1255P-0145P

GUID 6 CRN: 10952 LS106 MARQUEZ C W 1120A-0125P
Additional meeting required on Mondays from 1120 am - 1210 pm in LS106.

CRN Type Room Instructor Hrs. Units Days Begin-End

GUID 563A Directed Study Lab in Algebra

Transferable: No

This course is designed for students who have demonstrated difficulty mastering elementary algebra and who are eligible to receive Learning Disability Services. Course content parallels Mathematics 205A. Material is presented in a concrete, multi-sensory manner, and the lab allows opportunity for immediate practice, questions, repetition, and review. This is a pass/no pass course. COREQUISITE: Concurrent enrollment in MATH 205A is required. ADVISORY: Completion of GUID 557 or demonstrated deficit in mathematics. Recommended for students with verified learning disability.

10212	Lab	APE120/121	Overson R	3.20	1.0	MW	1120A-1240P
	ARR		TBA	1.00			

GUID 564 Directed Study Lab in Pre-Algebra

Transferable: No

This course is designed for students who are eligible to receive Learning Disability Services and/or who have demonstrated difficulty in mastering pre-algebra. The course content parallels Mathematics 402. The material is presented in a concrete, multi-sensory manner, and the lab environment allows opportunity for immediate practice questions, repetition and review. Units earned do not count towards the associate degree and/or certificate requirements. This is a pass/no pass course. COREQUISITE: Concurrent enrollment in MATH 402. ADVISORY: Completion of Guidance 557 and/or a demonstrated deficit in Mathematics. Recommended for students with verified learning disability.

10978	Lab	BU117	Burgman L	3.20	1.0	MW	0945A-1105A
-------	-----	-------	-----------	------	-----	----	-------------

Information Science: see CSIS

HEALTH EDUCATION

HE 1 Health Education

Transferable: CSU, UC; CSU-GE:E2; GAV-GE:E2

This course focuses on attaining individual awareness, critical-thinking skills and self-responsibility relating to personal health. The interaction of individual physical, psychological, social, emotional, spiritual and environmental factors in determining health status is developed through integration of major concepts. This course has the option of a letter grade or pass/no pass. ADVISORY: Eligible for English 250 and English 260.

10529	Lec	LS106	Dodd S	3.20	3.0	TR	0945A-1105A
-------	-----	-------	--------	------	-----	----	-------------

10530 Online N/A Quatre S 3.0
 This online class will be delivered entirely over the Internet. After enrolling, start the class by going to <http://www.gavilan.edu/disted>, and log into the system. Students who have not logged in by 5 pm on the 3rd day may be dropped from the class.

10531	Lec	HOL5	Dodd S	3.30	3.0	W	0600P-0905P
-------	-----	------	--------	------	-----	---	-------------

Above class meets at the Hollister Briggs site.

HE 2 Human Sexuality

Transferable: CSU, UC; CSU-GE:E2; GAV-GE:E2

Assists students in gaining increased knowledge, appreciation, and respect for their own sexuality, as well as others. Approved by the Board of Registered Nursing for 54 hours of continuing education credit (Provider #00892). ADVISORY: Eligible for English 250 and English 260

10533	Lec	LS106	Logan C	3.20	3.0	MW	0945A-1105A
-------	-----	-------	---------	------	-----	----	-------------

10532 Online N/A Quatre S 3.0
 This online class will be delivered entirely over the Internet. After enrolling, start the class by going to <http://www.gavilan.edu/disted>, and log into the system. Students who have not logged in by 5 pm on the 3rd day may be dropped from the class.

CRN Type Room Instructor Hrs. Units Days Begin-End

HISTORY

HIST 1 United States History through Reconstruction

Transferable: CSU, UC; CSU-GE:D6, C2; IGETC:3B, 4F, 7B; GAV-GE:C2, D2; CAN:HIST8, HIST SEQ B

History of the United States from the time before European contact with the Americas through Reconstruction. Emphasis will be placed on distinctive patterns of political, economic, social, intellectual, and geographic developments within their global context. At the conclusion of the course, the student should understand major themes in the history of the United States, and be able to explain various ways in which ideas about federal vs. state power, ethnicity, class, and gender divisions have influenced the nation's development. This course has the option of a letter grade or pass/no pass. ADVISORY: Eligible for English 250 and English 260.

10219	Lec	SS214	Halper L	3.20	3.0	TR	0945A-1105A
-------	-----	-------	----------	------	-----	----	-------------

10221	Lec	SS110	Mosher C	3.20	3.0	MW	0945A-1105A
-------	-----	-------	----------	------	-----	----	-------------

10222	Lec	HOL1	Luna E	3.20	3.0	TR	1120A-1240P
-------	-----	------	--------	------	-----	----	-------------

Above class meets at the Hollister Briggs site.

10217	Lec	SS210	Halper L	3.20	3.0	MW	0230P-0350P
-------	-----	-------	----------	------	-----	----	-------------

10236	Lec	SS214	Halper L	3.30	3.0	R	0600P-0905P
-------	-----	-------	----------	------	-----	---	-------------

HIST 2 United States History Reconstruction to the Present

Transferable: CSU, UC; CSU-GE:D6, C2; IGETC:7B, 3B, 4F; GAV-GE:D2, C2; CAN:HIST10, HIST SEQ B

History of the United States from Reconstruction to the present. Emphasis will be placed on distinctive patterns of political, economic, social, intellectual, and geographic developments within their global context. At the conclusion of the course, the student should understand major themes in the history of the United States, and be able to explain various ways in which ideas about federal vs. state power, ethnicity, class, and gender divisions have influenced the nation's development. This course has the option of a letter grade or pass/no pass. ADVISORY: Eligible for English 250 and English 260.

10238 Online N/A Guardino L 3.0
 This online class will be delivered entirely over the Internet. After enrolling, start the class by going to <http://www.gavilan.edu/disted>, and log into the system. Students who have not logged in by 5 pm on the 3rd day may be dropped from the class.

10239	Lec	SS205	Mosher C	3.20	3.0	MW	0810A-0930A
-------	-----	-------	----------	------	-----	----	-------------

10240	Lec	HOL2	Luna E	3.20	3.0	TR	0945A-1105A
-------	-----	------	--------	------	-----	----	-------------

Above class meets at the Hollister Briggs site.

10241	Lec	SS214	Luna E	3.20	3.0	MW	1250P-0210P
-------	-----	-------	--------	------	-----	----	-------------

10237	Lec	HOL2	Luna E	3.30	3.0	T	0600P-0905P
-------	-----	------	--------	------	-----	---	-------------

Above class meets at the Hollister Briggs site.

HIST 3 History of California

Transferable: CSU, UC; CSU-GE:D6, C2; IGETC:4F, 3B; GAV-GE:C2, D2, F

A study of California's history from pre-contact with Europeans to the present day. Social, cultural, economic, political and environmental issues will be explored towards an understanding of California's history. ADVISORY: Eligible for English 1A and English 260.

10245	Lec	SS110	Halper L	3.20	3.0	TR	1250P-0210P
-------	-----	-------	----------	------	-----	----	-------------

This service learning course section involves community work

HIST 4B History of World Societies 1500 to Present

Transferable: CSU, UC; CSU-GE:C2, D6; IGETC:3B, 4F; GAV-GE:C2, D2

A study of major elements in the development of and interactions between world societies, from the dawn of the Renaissance to the modern day. Students will comparatively analyze the social, cultural, geographic, economic, demographic, technological, environmental, and political developments that moved humans from the Middle Ages to the modern era. This course has the option of a letter grade or pass/no pass. ADVISORY: English 250 and English 260.

10243	Lec	SS205	Mosher C	3.30	3.0	M	0600P-0905P
-------	-----	-------	----------	------	-----	---	-------------

What is a CRN?

CRN stands for Course Reference Number. This is the number (used to be called section) that you will use to register for your classes.

CRN Type Room Instructor Hrs. Units Days Begin-End

HIST 5 Women's Lives in Early United States History

Transferable: CSU, UC; CSU-GE:D4, C2, D6; IGETC:4F, 3B; GAV-GE:C2, D1, D2, F
 This survey course begins with pre-contact peoples and extends to the end of the nineteenth century. The class examines the construction of womanhood through United States history, and the effects of gender, ethnicity, class, and sexual orientation upon women's experiences. Students will study the contributions of various individual women and groups of women in creating the modern United States, and will analyze social, political, economic, and cultural forces affecting women to both join and resist movements for social change. Students will also learn to apply contemporary feminist theory to traditional historical approaches. This course has the option of a letter grade or pass/no pass. **ADVISORY:** Eligible for English 250 and English 260.

10248 Lec SS205 Halper L 3.20 3.0 MW 1120A-1240P
 This service learning course section involves community work

HIST 7A History of Western Civilization

Transferable: CSU, UC; CSU-GE:C2; IGETC:3B; GAV-GE:C2; CAN:HIST2, HIST SEQ A
 A study of major elements in Western heritage from the ancient world to the eighteenth century. Course will survey intellectual, political, social, economic and cultural development of the Western World. **ADVISORY:** English 250 and English 260.

10249 Lec SS205 Kier D 3.20 3.0 TR 0810A-0930A

HIST 12 Cultural History of the Mexican American

Transferable: CSU, UC; CSU-GE:D6, D3, C2; IGETC:4F, 3B; GAV-GE:D2, F
 The Mexican American experience as influenced by society in the United States. Emphasis will be on the historical and contemporary contributions made by the Indian, Spanish, Mexican, and Mexican American. Emphasis will also be on the social, economic, and political milieu of the Mexican American within the context of the American society. This course has the option of a letter grade or pass/no pass. **ADVISORY:** Eligible for English 250 and English 260.

10250 Lec SS214 Luna E 3.20 3.0 MW 0945A-1105A

HIST 21 Ancient Americas: A History through Art

Transferable: CSU, UC; CSU-GE:C1, C2; IGETC:3A; GAV-GE:F
 A critical survey of history through the arts of pre-Columbian natives of North, Central and South America. The course will cover major societies and events from the appearance of major civilizations through the initial colonization efforts of European nations. Due to the distinct history of the Americas, this course uses the arts - architecture, sculpture, ceramics and painting, among others - of ancient societies as a primary source material. This course has the option of a letter grade or pass/no pass. This course is also listed as ART 21. **ADVISORY:** Eligible for English 250.

10568 Lec HOL5 Martinez E 3.20 3.0 TR 0230P-0350P
 Above class meets at the Hollister Briggs site.

HIST 23 Independent Study

Transferable: CSU
 Designed to afford selected students specialized opportunities for exploring areas at the independent study level. The courses may involve extensive library work, research in the community, or special projects. May be repeated until six units of credit are accrued. This course has the option of a letter grade or pass/no pass. **REQUIRED:** The study outline prepared by the student and the instructor must be filed with the department and the dean.

10254 Ind SS112 Luna E 1.0



Brush Up your Software Skills

Most Computer Applications classes are repeatable.

CRN Type Room Instructor Hrs. Units Days Begin-End

HUMANITIES

HUM 3 Introduction to the Cinema

Transferable: CSU, UC; CSU-GE:C2; IGETC:3B; GAV-GE:C2
 This course provides an introduction to the cinema. It includes a view of the inventors and the technological developments that led to the modern motion picture; an historical perspective on the growth and development of cinema including significant films that contributed to its establishment as an art form, a study of film genres such as the comedy, the musical, and the western; the technology of image and sound; and a look at the basic techniques of filmmakers when they attempt to convey meaning. **ADVISORY:** Eligible for English 250 and 260.

10501 Lec SS214 Richards G 3.20 3.0 MW 1120A-1240P
 10502 Lec SS214 Richards G 3.20 3.0 TR 1250P-0210P

HUM 4 Introduction to American Cinema

Transferable: CSU, UC; CSU-GE:C2; IGETC:3B; GAV-GE:C2
 This introductory course in film studies is a survey of the American film industry as an art form, as an industry, and as a system of representation and communication. The course explores how Hollywood films work technically, aesthetically, and culturally to reinforce and challenge America's national self-image. **ADVISORY:** English 440

10555 Online N/A Richards G 3.0
 This online class will be delivered entirely over the Internet. After enrolling, start the class by going to <http://www.gavilan.edu/disted>, and log into the system. Students who have not logged in by 5 pm on the 3rd day may be dropped from the class.

HUM 23 Independent Study

Transferable: CSU
 Designed to afford selected students specialized opportunities for exploring areas at the independent study level. The courses may involve extensive library work, research in the community, or special projects. May be repeated until six units of credit are accrued. This course has the option of a letter grade or pass/no pass. **REQUIRED:** The study outline prepared by the student and the instructor must be filed with the department and the dean.

10504 Ind HU111 Richards G 1.0
 10505 Ind HU111 Richards G 2.0