



Fall 2008

REGISTRATION

WHEN?

PRIORITY REGISTRATION FOR CONTINUING STUDENTS

May 5 - 9

NEW TRANSFER INSTITUTE STUDENTS

May 12 - 11

NEW, RETURNING* & HIGH SCHOOL CONTRACT STUDENTS

May 12 - Sept 2

High School Contract Students: May 10 - Aug. 29

LATE REGISTRATION (New, Continuing, Returning or High School Students)

Sept 3 - 9

OPEN ENTRY & LATE-START CLASSES

Consult the "Short-term Courses & Late Start Course List" online. Students must be registered before the first day of a late-start course.

* A **"returning" student** is a student who has been absent from Gavilan College for a semester or more.

REGISTER IN PERSON

WHERE?

MAIN CAMPUS

May 5 - 30 Mon-Thurs, 8 am - 4:30 pm; Fri, 9 am - 4:30 pm

Note: No in-person registration on Monday, May 26 (Memorial Day Holiday)

June 2 - Aug 15 Mon-Thurs, 8 am - 5 pm; Fri, 9 am - 11:30 am

Note: No in-person registration on Friday, July 4 (Independence Day Holiday)

Aug 18 - 22 Mon - Thurs, 8 am - 6 pm, Fri 9 am - 11:30 am

Aug 25 - 29 Mon - Thurs, 8 am - 7 pm; Fri, 9 am - 4:30 pm

Note: No in-person registration on Monday, Sept 1 (Labor Day Holiday) or Tuesday, Sept. 2 (Staff Development Day)

Sept 3 - 9 Mon - Thurs, 8 am - 7 pm, Fri, 8 am - 4:30 pm

MORGAN HILL AND HOLLISTER SITES

May 5 - 22 Mon-Thurs: 8 am - 8 pm, Fri: 8 am - 5 pm

May 27 - June 13 Mon-Thurs: 8 am - 5:30 pm, Fridays 8 am - 12 noon

June 16 - July 25 Mon-Thurs. 8 am - 8 pm; Fri. 8 am - 12 noon

July 28 - Sept 9 8 am to 5:30 p.m. M - Th., Fri. 8 am - 12 noon.

Notes: Sites are open on Fridays beginning May 30 from 8 am to 12 noon.

May 23 - Closed for Graduation

May 26 - Closed for Memorial Day

July 4 - Friday - Closed for Independence Day Holiday

July 11 - Hollister site will be closed

Register Online if:

1. You are a continuing student or have submitted an application to the Admissions & Records Office or at one of the sites at least 48 hours prior to registering.
2. You have no "holds".
3. You are signing up for courses with prerequisites that you have successfully completed at Gavilan or have been verified by placement assessment or evaluation of official transcripts from another college.
4. You are not in "dismissed" status.

APPLY & REGISTER ONLINE!

Go to www.gavilan.edu
and click on the Self-Service Banner icon

Beginning with the summer 2008 enrollment period, social security numbers will no longer be used as student identifiers. Find your new Gavilan Student ID and choose a log-on PIN by going to www.gavilan.edu and clicking on the Self-Service Banner icon. You will use your new ID and PIN to log into Self-Service Banner and register for summer and fall classes.

- ✓ Register/Add/Drop Classes
- ✓ Check Class Availability and Fees
- ✓ Choose Pass/No Pass Options
- ✓ Purchase Parking Permits or Student ID Cards
- ✓ Check Prerequisites
- ✓ Print an Unofficial Transcript
- ✓ Check out classes sorted by day, start date, method of instruction and more on the web!

CREDIT CARDS accepted:

American Express, Discover, MasterCard or Visa

Online Help

During in-person registration hours- (408) 848-4733



NEW - Pay in person with credit card or electronic check at the Admissions & Records office or at either site or by calling toll-free 1-866-255-1801.

Registration fee payment schedule

see page 7.

Policies have changed regarding:

- ◆ repeatability of classes
- ◆ calculation of grades after multiple repeats
- ◆ withdrawal policy
- ◆ naming of Certificates

Check the Catalog online at www.gavilan.edu/catalog

Fall Semester Calendar - see page 4

You are eligible to ATTEND GAVILAN COLLEGE if:

- ◆ You are a high school graduate or
- ◆ You have passed the GED or
- ◆ You are 18 years of age or older or
- ◆ You have passed the California High School Proficiency exam or
- ◆ You are currently enrolled in high school. High School students may enroll with Special Student Status by completing a High School Contract form.

PLACEMENT/ASSESSMENT testing will help ensure that students are enrolled in courses that match their abilities in language and computational skills. Students must have completed the eighth grade to be eligible for assessment services. Placement scores, together with other indicators of a student's abilities, are used by counselors to determine appropriate course placements.

If you have attended another college and completed math and English courses within the past two years, you do not need Gavilan's placement assessment unless you wish to take it or it is required by your major.

See a COUNSELOR if:

- ◆ you are a first time student planning to transfer
- ◆ you are a first time student planning to obtain an AA/AS degree
- ◆ you are undecided about a major
- ◆ you are a high school contract student
- ◆ you are an academic probation student or in a "disqualified" status
- ◆ you are an international student
- ◆ you are taking over 17.99 units (spring/fall) or over 5.99 units (summer)
- ◆ you have completed prerequisite courses at another college
- ◆ your class has a prerequisite that was not successfully completed at Gavilan

Getting Started

ADDING AND DROPPING COURSES

Students may add and/or drop courses

- **online** (Click on the Self-Service Banner icon at www.gavilan.edu).
- **in person** on the main campus or at the Morgan Hill or Hollister sites.

A student who stops attending a course and does not officially drop is **not** automatically dropped by the instructor and may receive a final grade of "F".

CLASS CONFLICTS

In the event of a class conflict, students must FIRST receive written approval from instructor(s) noting that they are aware there is a class conflict and how work/time will be made up (where applicable).

ADD CODES

are obtained from an instructor during late registration for closed (full) classes.

They must be used by Tuesday, September 9...

...until 7 pm for in person registration or

...until 12 midnight for online registration (Self-Service Banner)

New Students Registration Checklist

In order to be exempt from assessment and orientation you must:

- ◆ have an AA degree or higher or
- ◆ have accumulated fewer than 12 units in transfer courses or
- ◆ be presently enrolled in fewer than six units or
- ◆ not plan to earn a certificate or degree.

Opt out by completing a waiver form at the Admissions & Records Office. Doing this will prevent you from participating in priority/early registration.

- 1) APPLICATION** File at least two working days before registering. Go to www.gavilan.edu and click on the link for Gavilan's online application.
- 2) PLACEMENT/ASSESSMENT TEST** Sign up in person or by calling (408) 846-4992 or (408) 846-4954.
 - a. If you have attended another college you may submit placement test scores from that college to a counselor for evaluation.
 - b. Results are posted approximately 24 hours after test completion.
 - c. If you do not dispute the results of your placement exams, you may register for classes without seeing a counselor.
- 3) ORIENTATION** online or in person
- 4) REQUEST A TRANSCRIPT** from your high school if you graduated within the past five years and have not yet attended college. Request a transcript from any colleges you have attended.
- 5) SEE A COUNSELOR**
- 6) REGISTER FOR CLASSES** go online to www.gavilan.edu and click on Self-Service Banner to find your Gavilan ID number and select a user ID and PIN. Register!
- 7) PAY FEES** in person or by calling 1-866-255-1801 (toll free). See payment deadline chart on page 7.

OUR MISSION *In an environment that cultivates creativity, stimulates curiosity and emphasizes student learning, Gavilan College serves its community by providing high quality educational and support services that prepare students for transfer, technical and public service careers, life-long learning and participation in a diverse global society.*

CONTENTS

Register for Fall Classes.	inside front
Getting Started.	1
Telephone Numbers.	3
Fall Semester Calendar.	4
Administrators/Board of Trustees.	5
How to Use the Schedule.	6
Fees.	7
Financial Aid.	8-9
Matriculation.	10-11
Assessment/Orientation/Counseling Services	
High School Students.	12-16
Concurrent Enrollment/Gilroy Early College Academy/ High Step Program/Transfer Institute	
2007 Report to the Community.	17-20
Summer Session :	
Registration Schedule.	21-23
Gavilan Online & SJSU Telecourses.	24
Morgan Hill and Hollister Classes.	25
Summer Classes.	26-42
Summer Noncredit Classes.	43-45
Fall Semester:	
Gavilan Online & SJSU Telecourses.	46-47
Morgan Hill Classes.	48-49
Hollister Classes.	50-51
New Fall Classes.	53
Fall Classes.	52-110
First Year Experience.	82-83
Noncredit Classes.	111-114
ROP Classes.	115-117
Final Exam Schedule.	117
Student Services.	118-119
General Education.	120
Instructional Support and Labs.	121-122
Transfer.	122-129
General Information.	130
Student Life.	131
Policies and Procedures.	132-133
English as a Second Language (ESL).	134
Información en Español.	134-137
Forms.	138-end
Maps.	inside back cover
Información en Español.	134-137

Gavilan College - Big Time Education, Hometown Location



Are you a typical Gavilan College student? Probably not, because there really isn't one. Some students are here to enhance their careers with specialized training in a technical field. Many come to Gavilan College to complete their lower division general education requirement before transferring to a university. Hundreds each year earn their first college degree

-- an Associate of Arts or Associate of Science. There are those students, too, who take one or two classes at Gavilan College to explore a new field, or for personal enrichment.

Some students attend straight out of high school, some while they are still in high school. Some students return after years away from formal education. Many are working while they go to school. Some are parents. Some are grandparents.

What Gavilan College students all have in common is a shared desire to achieve their personal goals. They recognize the value of our small classes, beautiful setting, talented staff, low fees, financial aid and other student services, and convenient times and locations for classes. We're here to help you achieve your goals, with classes and services that fit into your life.

Have a great semester!

Sincerely,

Steven M. Kinsella, D.B.A.

Schedule Development Team

Rosie Armstrong, Mimi Arvizu, Sherrean Carr, Jan Bernstein Chargin, Michele Cortes, Katie Day, Bonnie Donovan, Fran Lopez, Michelle Lopez, Fran Lozano, Oralis Magaña, Terri Newman, Jesus Olivas, Joy Parker, Rachel Perez, Dave Phillips, John Pruitt, Diane Stone, Cindy Starr

Cover by: Jan Bernstein Chargin

Photos by: Jan Bernstein Chargin, Pablo Balacio, Cindy Starr, The Gilroy Dispatch

Printed by: Casey Printing

GAVILAN COLLEGE SATELLITE LOCATIONS:

Morgan Hill Community Site

Gavilan College Building
17060 Monterey Road
Morgan Hill, CA 95037
408-782-2873

Hollister, Briggs Bldg.

365 Fourth St.
Hollister, CA 95023
831-636-3783

Hollister Airport

490 Skylane Drive
Hollister, CA 95023
831-637-1151

Main Campus	408-848-4800
from Hollister, call toll free637-1158
Morgan Hill Site	408-782-2873
Hollister Site, Briggs Building	831-636-3783
Campus Security (non-emergency)	408-848-4703
Emergency: First: Dial '911' (On campus, dial '8' first.)	
Second: Dial '10' for campus emergency support.	
From campus pay phone: Dial 408-710-7490	
Cell phone: 408-710-7490	

Admissions & Records	408-848-4735 or 846-4954
transcripts	408-848 4733
grading	408-848 4751
applications	408-848 4736
graduation	408-848 4737
Allied Health	408-848-4883
ASB Advisor	408-846-4972
ASB Office	408-848-4777
Assessment Office	408-846-4992
Athletics/Physical Education	408-848-4876
Aviation	831-637-1151
Basic Skills	408-848-4820
Bookstore	408-848-4742
Business Skills Center	408-848-4786
California Applied Biotechnology Center (CalABC)	408-848-4828
CalWORKs	408-848-4813
CARE - Cooperative Agencies Resources for Education	408-848-4790
Career/Transfer Resource Center	408-848-4818
Cashier	408-848-4714
Child Development Center	408-848-4815
CMAP - Community Media Access Partnership	408-846-4983
Community/Contract Education	408-847-2514
Computer Place	408-848-4729
Cooperative Work Experience	408-846-4993
Cosmetology Appointment line	408-842-5055
Counseling Office	408-848-4723
Digital Media - CGD lab (Studio DM)	408 848-4800, ext. 5604
DRC - Disability Resource Center	408-848-4865
Discrimination-Harassment Complaints	408-848-4731
Distance Education Coordinator	408 848-4885

Early College Academy (GECA)	408-846-4909
EOPS - Extended Opportunity Programs & Services	408-848-4740
ESL Computer Lab	408-848-4856
Evening Office	408-848-4276
Financial Aid	408-848-4727
First Year Experience	408-848-4723
Foundation/Fundraising	408-846-4936
GavTV, Channel 18	408-848-4764
The Gavilan Press	408-848-4837
to fax news events	408-848-4827
Health Services	408-848-4791
Human Resources	408 848 4755
Instructional Services, Vice President's Office	408-848-4761
International Students	408-848-4754
Liberal Arts & Sciences, Dean's Office	408-848-4701
Library	408-848-4810 or 408-848-4806
Math Lab	408-846-4959
MESA - Math, Engineering, Science Achievement	408-846-4968
Noncredit Program (Community Development)	408-848-4800, ext. 5116
Placement/Assessment Testing	408-846-4992
Sign up	408-846-4954
Online/Telecourses	408 848-4885
Outreach & Recruitment/Tours	408-846-4993
President's Office	408-848-4711
Public Information Office	408-848-4724
Puente Program	408-848-4807
Reading Lab	408-846-4980
R.O.P. - Regional Occupational Programs	408-848-4816
STAR-Summer Theatre Arts Repertory	408-612-2057 or 848-4764
Student Services, Vice President's Office	408-848-4738
Technical and Public Services, Dean's Office	408-848-4719
Telephone Registration (GavNOW)	408-846-3729
Theatre Arts Box Office	408-846-4973
Transfer (Career/Transfer Resource Center)	408-848-4818
Transfer Institute	408-848-4723
TRIO Student Support Services	408-846-4981
TTY (for Deaf or Hard of Hearing)	408-846-4924
Tutoring Center	408-848-4838
Veterans' Services	408-848-4734
Work Experience	408-846-4993
Writing Center	408-848-4811

**save gas!
save time!
save energy!**

Take 12 units of transferable general education classes at the Morgan Hill and Hollister sites in the fall.

For a list of courses offered, see pages 48 and 50.

El Proceso de Registración para el Programa de ESL

Consulte la página 134.

Check out Online Registration

go to www.gavilan.edu and click on the Self-Service Banner Icon



Gavilan College

Fall 2008 Semester

CALENDAR

ALTERNATE FORMATS:

The Gavilan College Schedule of Classes is available in alternate media formats. Contact the Disability Resource Center (408-848-4865) or the Office of the Vice President of Student Services (408-848-4738).

FORMAS ALTERNATIVAS:

El Horario de Clases del Colegio Gavilán está disponible en formato de medios alternos.

Por favor de contactar El Centro de Recursos Para Estudiantes con Incapacidades (DRC) (408-848-4865) o la Oficina del Vicepresidente de Servicios de Estudiante (408-848-4738).

AVIATION FIRST DAY OF INSTRUCTION **Wed, Aug 13**

FALL SEMESTER BEGINS **Wed, Sept 3**

LAST DAY TO OBTAIN & USE ADD CODES **Tues, Sept 9**

for closed classes (unless class is open entry or late-start.) See list of open-entry classes online.

ADD CODES ACCEPTED UNTIL **Tues, Sept 9 at 10:00 pm**

Students must use add code to register in person no later than this date. Students may add "open" courses in-person or online until this deadline.

LAST DAY TO DROP WITH A REFUND **Wed, Sept 17**
See page 7.

"NRS" DEADLINE **Fri, Oct 3**

"No Record Shown". Semester-long courses dropped by this date do not appear on the student's permanent record. The "NRS" deadline for a short-term course is 30% of the class meetings.

DEADLINE FOR GRADING OPTION **Fri, Oct 3**

Last day to select the Pass/No pass Grade option for designated, semester-long courses.

FALL GRADUATION PETITIONS DUE **Mon, Oct 13**

See a counselor to complete a petition to graduate at the end of the fall semester.

VETERANS' DAY HOLIDAY **Mon, Nov 10**

No day or evening classes.

"W" DEADLINE **Fri, Nov 21**

Semester-long courses dropped by this date appear on the student's permanent record with a notation of "W" for withdrawn. The "W" deadline for a short-term course is 75% of the course meetings.

THANKSGIVING HOLIDAY **Thurs-Sun, Nov 27-30**

No day, evening or weekend classes.

TRANSFERRING STUDENTS **Mon, Dec 15**

Students transferring to a CSU or UC campus in the spring should request an official transcript to be sent at the end of the semester and GE or IGETC certification from the Admissions and Records Office by this date.

FINAL EXAMS **Mon-Sun, Dec 15-21**

LAST DAY OF SEMESTER **Sun, Dec 21**

FINAL GRADES AVAILABLE **Tues, Jan 6, 2009**

Grades available online at www.gavilan.edu (click on the Self-Service Banner icon)

OFFICIAL TRANSCRIPTS AVAILABLE **Mon, Jan 26, 2009**

Unofficial grades available online (www.gavilan.edu)

Administrators

Steven M. Kinsella, D.B.A., C.P.A.

Superintendent/President

Victor Krimsley, Ph.D.

Interim Vice President of Instructional Services

Joseph Keeler, C.P.A.

Vice President of Administrative Services

John Pruitt

Vice President of Student Services

Fran Lozano

Dean of Liberal Arts and Sciences

Sherrean Carr

Dean of Technical and Public Services

Ron Hannon

Dean of Physical Education and Athletics

Fran Lopez

Associate Dean of the Disability Resource Center

Rachel Perez

Associate Dean of Community Development/Grants Management

Anne Ratto

Associate Dean of EOPS/CalWORKs and CARE

Gavilan Joint Community College District

Board of Trustees

Tom Breen, San Benito County

B.S., J.D., Santa Clara University

Kent Child, San Benito County

A.A., College of San Mateo; B.A., M.A., San Jose State University

Mark Dover, Gilroy

B.S., M.A., San Jose State University

Laura Perry, Esq., Morgan Hill

A.A., Gavilan College, B.S., San Jose State University; J.D., Santa Clara University

Elvira Robinson, Esq., San Benito County

B.A., J.D., Santa Clara University

Deb Smith, Gilroy

B.S., University of Phoenix

Leonard Washington, Morgan Hill

B.A., Texas Southern University, M.A., Santa Clara University

Andrew Williams, Student Trustee

Degrees Currently Offered

by Gavilan College

Associate of Arts

Administration of Justice

Art

Business

Child Development

Fine Arts

Interpersonal Communication

Language Arts

Liberal Arts *various emphasis areas*

Media Arts

Music

Physical Education

Social Science

Spanish

Theatre Arts

Associate of Science

Aviation Maintenance Technology

Biological Science

Business: Economics Option

Computer Graphics & Design

Computer Science & Information Systems

Cosmetology

Digital Media

Engineering & Physical Science

Health Science

Mathematics

Nursing (LVN/RN)

GavFEST 2007

Be careful!

Measure E campus improvements and construction projects are underway!

ACCURACY STATEMENT: The Gavilan Joint Community College District and Gavilan College have made every reasonable effort to ensure that the 2008 Summer/Fall Class Schedule is accurate. Courses and programs that are offered, along with other information in the schedule, are subject to change without notice by the Gavilan College administration for reasons related to student enrollment, level of financial support, or for any other reason, at the discretion of the district and the college. The district and college further reserve the right to add to, amend, or repeal any of its rules, regulations, policies, and procedures, consistent with applicable laws.

HOW TO USE THIS SCHEDULE

Transferable

Includes:
 CSU, UC
 CSU-GE area designation
 IGETC area designation
 Gavilan AA/AS General Education designation
 CAN #: For more information, refer to the General Education/ Course Credit Matrix on page 57 of the 2007-2009 Gavilan College Catalog.

Prerequisites

(Refer to the College Catalog for Advisories for most courses. See page 130 of this schedule for an explanation of Advisories, Prerequisites and Co-requisites.)

Course Number	Course Title	Discipline					
		BUSINESS					
	BUS 1 Fundamentals of Business						
	Transferable: CSU; UC; GAV AA/AS, D2						
	Course Description						
	REQUIRED/ADVISORY: Listed at the end of the course description						
CRN	Type	Room	Instructor	Hrs.	Units	Days	Begin-End
10000	LEC	BU120	ROSS Y	3.20	3.0	TR	1250P 0210P
10100	LEC	BU119	STAFF	3.30	3.0	T	0600P 0905P

Course Reference Number
 10000, 10100

Building/Room
 BU120, BU119

Instructor
 ROSS Y, STAFF

Instructional Type
 LEC Lecture
 LAB Laboratory
 L/L Lecture/Laboratory
 TV Telecourse

Semester Units
 3.20, 3.0, 3.30, 3.0

Class Hours per week
 TR, T

Evening & weekend Courses
Listed in gray shade

Schedule Legend

M	Monday
T	Tuesday
W	Wednesday
R	Thursday
F	Friday
S	Saturday
U	Sunday
ARR	Additional weekly hours required
FEX	Field Experience
TBA	to be arranged
TV	Telecourse
Wrk Ex	Work Experience

Gray shading indicates evening and weekend classes

On-Campus Buildings

AL	Art Lecture
APE	Adaptive Physical Education
AR	Art
BOB	Business Offices
BU	Business
CD	Child Development Ctr.
CH	Chemistry
CHP	Chapel
CJ	Classrooms
CO	Cosmetology
GY	Gym
HOB	Health Occupations Bldg.
HR	Human Resources
HRC	Human Resources Conference Room
HU	Humanities
LI	Library
LS	Life Science
MAY	Mayock House
OE	Classrooms
PA	Police Academy
PB	Portable Building
PH	Physical Science
SC	Student Center
S/M	Security/Maintenance
SS	Social Science
TH	Theatre

Off-Campus Buildings

ANZ	Anzar High School, San Juan Bautista
AROMAS	Aromas School, 365 Vega St., Aromas
AV	Aviation, Hollister Airport
CRC	Centennial Recreation Center, 171 W. Edmundson Ave., Morgan Hill
CTC 1-4	South Valley Middle School, 7881 Murray Ave., Gilroy
DPB	Dunne Park Bldg., West & 6th St., Hollister
EGLRIG	Eagle Ridge Golf Course, Santa Teresa Blvd., Gilroy
GHS	Gilroy High School, 750 W 10th St., Gilroy
GSC	Gilroy Senior Center, 7371 Hanna Street, Gilroy
HARDIN	R. O. Hardin School in Hollister
HHH	Hazel Hawkins Hospital, 911 Sunset Drive, Hollister
HOL	Hollister Briggs Bldg, 365 Fourth St. Hollister
HOLREC	Hollister Recreation, 375 West St., Hollister
HOPE-G	Hope at Gilroy
HOPE-H	Hope at Hollister
HVME1	Hacienda Valley Mobile Estates, 275 Burnett Ave., Morgan Hill
JDA	Jovenes de Antano, 300 West St., Hollister
JS	Jasmine Square, 16530 Monterey Rd., Morgan Hill
LOADCS	Live Oak Adult Day Care Services, 651 W. 6th St., Gilroy
LOHS	Live Oak High School
MHG	Morgan Hill Community Center, 17060 Monterey Rd., Morgan Hill
OMC	Ochoa Migrant Camp
PORTHL	Portuguese Hall, 695 Seventh St., Hollister
PLY	Morgan Hill Playhouse, Monterey Highway and Dunne, Morgan Hill
SB	San Benito High School
S.BRAT	Sobrato High School, Morgan Hill
SOLB7	Solorsano Middle School, 7121 Grenache Way, Gilroy, room B-7
STF	St. Francis, 7950 Church St., Gilroy
SVALLY	South Valley High School
VG	Village Green, 7610 Isabella Way, Gilroy
VPRI	Valley Pines Retirement Inn, 545 E. Main Ave., Morgan Hill
WEX	Work Experience
WM	Wheeler Manor, 651 W. 6th St., Gilroy
YMCA	Morgan Hill YMCA, 17666 Crest Ave., Morgan Hill

Fees

Basic Fees

Per unit fee (California resident)	\$20
Per unit fee (non-resident)	\$204
Health Fee: fall/spring	\$15
summer	\$5
Campus Center Use Fee (fall & spring only) This fee is not required of students whose entire course load is held off campus.	\$1 per unit to a maximum of \$5
Student Representation Fee	\$1
Student Identification Card Fee: per semester	\$6
. per year	\$10

Registration Payment Deadline Schedule

Payment must be received and/or posted on or before the deadline listed to avoid being deregistered from the class.

Register Between	Payment Deadline
Tues, April 29 - Sun, May 4	Sunday, May 4 at midnight
Mon, May 5 - Sun, May 11	Sunday, May 11 at midnight
Mon, May 12 - Sun, May 25	Sunday, May 25 at midnight
Mon, May 26 - Sun, June 8	Sunday, June 8 at midnight
Mon, June 9 - Sun, June 22	Sunday, June 22 at midnight
Mon, June 23 - Sun, July 6	Sunday, July 6 at midnight
Mon, July 7 - Sun, July 20	Sunday, July 20 at midnight
Mon, July 21 - Sun, Aug 3	Sunday, Aug 3 at midnight
Mon, Aug 4 - Sun, Aug 17	Sunday, Aug 17 at midnight
Mon, Aug 18 - Sun, Aug 24	Sunday, Aug 24 at midnight
Mon, Aug 25 - Tues, Sept 9	Day of registration at midnight

Parking Permits

Required only on the Gilroy campus Monday-Friday

Day Permit (7 a.m. - 10 p.m.)	\$40
Day Permit with TANF/AFDC/SSI or Financial Aid.	\$20
Evening Permit (3 p.m. - 10 p.m.)	\$20
Summer	\$20

One-day permits may be purchased for 75 cents from the coin-operated machines located in parking lots A, E and at the south entrance to campus. Exact change is required.

Refunds Students must drop semester-long courses no later than **Wed., Sept. 17** and file a Request for Refund form no later than **Wed., Oct. 1, 2008**. Short-term courses must be dropped before 10% of the course meetings have passed. For one- or two-day courses, this date will occur before the start of the course.

Fees, minus a \$10 processing fee, will be refunded when semester-long courses are officially dropped by the refund date. Refunds are not automatic, even when a class is cancelled.

Student Health Fees Gavilan College is required to maintain health services and accident insurance for all students enrolled in credit classes. These services are covered by the \$15 health fee.

Student Representation Fee The Student Representation Fee is a \$1 per semester fee that students approved through a student body election. The student government (ASB) oversees and uses the fees to lobby and advocate for student issues and concerns at the state level. It also supports opportunities for students to attend leadership conferences on issues related to advocacy. Those students who do not wish to support these activities may request a refund directly from the ASB.

NEW - Pay in person with credit card or electronic check at the Admissions & Records office or at either site or by calling toll-free 1-866-255-1801. American Express, Mastercard, Visa or Discover accepted.

Fall 2008 Fee Schedule

TOTALS INCLUDE: \$20 per unit Enrollment Fee, \$184 Non-Resident Fee (if applicable), \$15 Health Fee, \$1 per unit Campus Center Use Fee (to a maximum of \$5), \$6 Student ID/Discount Card and \$1 Student Representation Fee.

Number of Units	California Resident	Non Resident Out-of-State	Number of Units	California Resident	Non Resident Out-of-State
0.5	32.50	125.00	9.5	217.00	1956.50
1.0	43.00	227.00	10.0	227.00	2058.00
1.5	53.50	329.00	10.5	237.00	2159.50
2.0	64.00	431.00	11.0	247.00	2261.00
2.5	74.50	533.00	11.5	257.00	2362.50
3.0	85.00	635.00	12.0	267.00	2464.00
3.5	95.50	737.00	12.5	277.00	2565.50
4.0	106.00	839.00	13.0	287.00	2667.00
4.5	116.50	941.00	13.5	297.00	2768.50
5.0	127.00	1043.00	14.0	307.00	2870.00
5.5	137.00	1144.50	14.5	317.00	2971.50
6.0	147.00	1246.00	15.0	327.00	3073.00
6.5	157.00	1347.50	15.5	337.00	3174.50
7.0	167.00	1449.00	16.0	347.00	3276.00
7.5	177.00	1550.50	16.5	357.00	3377.50
8.0	187.00	1652.00	17.0	367.00	3479.00
8.5	197.00	1753.50	17.5	377.00	3580.50
9.0	207.00	1855.00	18.0	387.00	3582.00

Courses With Additional Materials Fees

COURSE	DESCRIPTION	FEE
AH 32	BASIC CARD/LIFE SUP	\$12.00
AH 32	BASIC CARD/LIFE SUP	\$12.00
ART 80	DIGITAL PHOTOGRAPHY	\$20.00
CD 160	CHILD CARE 1ST AID	\$12.00
CSIS 80	DIGITAL PHOTOGRAPHY	\$20.00
DM 80	DIGITAL PHOTOGRAPHY	\$20.00
GUID 1	SELF ASSESSMENT	\$12.00
MUS 760	MUSIC ENCOUNTERS	\$12.00
PSYC 5	SELF ASSESSMENT	\$12.00

Fees payable to instructor or additional materials required

COURSE	DESCRIPTION	FEE
COS 200	BEGINNING COSMETOLOGY cosmetology kit	\$500 (approx.)
COS 201	INTERMEDIATE COSMETOLOGY manikin, pedicure kit and uniform	\$250 (approx.)
COS 202-203	ADV COS - PRACTICUM manikin, uniform and books	\$300 (approx.)
MATH 404A-G	SELF-PACED BASIC MATH	\$60
PE 17	GOLF facility use fee - details at first meeting	STBA
PE 20	BOWLING	\$1.50 per session
PE 39	FENCING	\$6.00 (payable to instructor)

Student Identification/Discount Card

The purchase of the Student ID/Discount Card benefits both the individual student and the college at large. The fees are budgeted by the Associated Student Body to develop and support campus activities, educational programs, speakers, and cultural events. Cardholders also receive numerous on and off campus benefits including:

- Free admissions to college athletic events
- Community-wide discounts such as reduced movie admissions, restaurant discounts, gym discounts, etc.
- Free bluebooks and scantrons in the college bookstore
- Eligibility for an ASB book loan

Students who do not wish to purchase the ID/Discount Card must decline the card in writing. Forms for requesting a waiver of this fee are available from the Admissions and Records Office, the Financial Aid Office, the Morgan Hill and Hollister sites, the ASB Office, and the ASB Advisor's office (located in the Counseling Department). These forms must be turned in at the time of registration. Requests for refunds must be processed through the ASB Advisor.

ASB cards are also available for purchase by Gavilan College staff through the Cashier's Office.

California Nonresident Tuition Fee Exemption (AB540)

AB540, as required by California law, provides an exemption from payment of non-resident tuition for eligible non-immigrant students. To be eligible, a student must have attended a California high school for three full years and have graduated from a California high school or have received the equivalent of a California diploma (GED, CHESPE). The exemption does not grant residency status and the qualifying student may not be eligible for state aid programs such as BOG, EOPS or federal financial aid. The student must sign an affidavit affirming that he or she has filed or will file an application with INS to legalize his or her immigration status as soon as he or she is eligible to do so. Contact the Admissions & Records Office for more information.

Dropped a class?

Want a refund?

Gotta ask or it won't happen.

see page 7.



Paying for College

APPLYING FOR FINANCIAL AID

Financial assistance with college expenses is available for students of all incomes.

FINANCIAL AID OFFICE

Room SC 124 408-848-4727

Open: Mon. - Thurs.: 8 a.m. - 5 p.m., Fri.: 8 a.m. - 3 p.m.

Evening hours: Hours are extended during peak registration periods.

www.gavilan.edu/finaid/

Gavilan College participates in several financial aid programs that are designed to provide assistance to students with documented financial need. This aid is provided from several sources: federal, state and private agencies.

Requirements for Financial Aid Applicants:

Financial aid applicants:

- Must demonstrate need according to the guidelines of each program
- Must be a U.S. citizen or eligible non-citizen
- Must be in good standing on a federal student loan or not owe a refund of student financial aid
- Must demonstrate eligibility to benefit from higher education
- Males must be registered with Selective Service
- Must maintain satisfactory academic progress.

Note: If you have been convicted of illegal drug use or sales you may be ineligible for some aid programs.

SATISFACTORY ACADEMIC PROGRESS (SAP) POLICY

The Gavilan College Financial Aid Office is required to measure your academic progress toward a Certificate, Associate, or Transfer Degree program. If you are not pursuing one of these programs, you are not eligible for financial aid. Your progress will be reviewed at least once per academic year.

If you are disqualified due to poor academic history, you must attend a SAP Policy Workshop. Stop by the Financial Aid Office to sign up for the SAP Policy Workshop.

What Financial Aid Applications do I complete?

BOG Application: For CA residents who meet income guidelines. If eligible, your enrollment fees are waived for an entire year: summer '08, fall '08 and spring '09 terms. Complete the 2008-09 BOG Application (Pages 139-140).

FAFSA (Free Application for Federal Student Aid): Determines your eligibility for federal and state grants as well as the fee waiver if you do not meet BOG income guidelines and are a CA resident. The FAFSA can be completed through paper application or online at www.fafsa.ed.gov. Be sure to add the Gavilan school code of 001202 so that the Financial Aid Office can receive your processed FAFSA. Complete the:

- 2007-08 FAFSA: if you will attend the summer '08 term
- 2008-09 FAFSA: if you will attend the fall '08, spring '09 or summer '09 terms

Cal Grant Application: For CA residents who meet various criteria, including income and GPA. The Cal Grant Application with a March 2nd, 2008 deadline determines your eligibility for Cal Grants A and B. Filing an 08-09 FAFSA is required for Cal Grant consideration.

Scholarship Applications: See the financial aid office for institutional scholarships and private scholarship information/materials.

Links to these applications are available online, through the Financial Aid Office webpage: www.gavilan.edu/finaid/

Financial Aid Programs

FEE WAIVER:

Board of Governor's Fee Waiver/BOG Program – waives mandatory enrollment fees for eligible students. This fee waiver is for students who are California residents. The BOG application is included on pages 139-140 of this schedule.

FEDERAL AND STATE GRANTS:

- Federal Pell Grant
- Federal SEO Grant
- Federal Work Study Grant
- Cal Grant (B and C)
- Chafee Grant
- Child Development Grant
- EOPS Grant
- TRIO Grant
- CARE Grant

FEDERAL WORK-STUDY GRANT: Provides the student with an opportunity to earn money while gaining valuable work experience and is awarded based on financial need.

SCHOLARSHIPS: Scholarships are awarded on the basis of academic achievement and/or financial need. Eligibility varies and is set by the scholarship donor. Gavilan College Educational Foundation Scholarship application is due March 2nd. Other private scholarship applications with various deadlines throughout the school year are available in the Financial Aid Office. See the Financial Aid website at www.gavilan.edu/finaid. We recommend you inquire about scholarships several times per semester as new scholarships are announced throughout the academic year as they become available.

VETERAN AFFAIRS BENEFITS: Gavilan College offers special assistance to student veterans and children of disabled veterans. Students having questions pertaining to eligibility, benefits, application procedures and other veteran matters should contact the Financial Aid Office at 408-848-4727.

STUDENT LOANS: Gavilan College participates in the Federal Family Educational Loan Program. If you are interested in applying for a student loans, complete the FAFSA & attend an Entrance Loan Counseling Session. Applications for the student loans are distributed at Loan Counseling Sessions.

Ability to Benefit

NEED FINANCIAL AID BUT HAVE NO HIGH SCHOOL DIPLOMA?

Federal regulations require students who do not have a high school diploma, General Educational Development (GED) certificate, or California High School Proficiency Exam (CHSPE) and who are applying for financial aid, to take an Ability to Benefit assessment. If you have a high school diploma (or equivalent) from another country you are exempt.

The Ability to Benefit ACT Asset schedule is listed below. To sign up for a session, call or come by the Financial Aid Office: 408-848-4727 (SC124).

ASSET Testing Schedule for Native English Speakers:

DAY	DATE	TIME	LOC
Friday	May 2	8:00 am -10:00 am	Gilroy BU-117
Friday	May 16	10:00 am -12:00 pm	Gilroy BU-117
Friday	June 20	8:00 am -10:00 am	Gilroy BU-120B
Friday	June 20	10:00 am -12 pm	Gilroy BU-120B
Thursday	June 26	9:00 am-11:00 am	Gilroy BU-120B
Friday	July 11	8:30 am -10:30 am	Gilroy BU-120B
Monday	July 21	9:00 am -11:00 am	Gilroy BU-120B
Monday	July 21	1:00 pm -3:00 pm	Gilroy BU-120B
Wednesday	Aug 06	9:00 am -11:00 am	Gilroy BU-120B
Friday	Aug 08	10:00 am -12 pm	Gilroy BU-120B
Wednesday	Aug 20	8:00 am -10:00 am	Gilroy BU-120B
Wednesday	Aug 20	10:00 am -12 pm	Gilroy BU-120B
Wednesday	Aug 27	1:00 pm -3:00 pm	Gilroy BU-120B

Times and locations subject to change and additional times may be added. Confirm time and location with the Assessment Office in BU120B - 408-846-4992 prior to testing date.

CELSA (Combined English Language Skills Assessment)

Students with limited English language skills who are enrolled in English as a Second Language (ESL) classes and do not have a high school diploma or GED and are applying for Financial Aid must take the CELSA assessment.

Call the Financial Aid Office (SC124) at 408-848-4727 for a referral. Then call the Assessment Office (BU 120B) at 408-846-4992 to schedule your appointment.

LOOK US UP ONLINE AT WWW.GAVILAN.EDU/FINAID/

Complete the FASFA at www.fafsa.ed.gov

Online financial planning guide & budget counseling at www.edwise.org

Check your Stafford loan status at www.elmresources.com

Online loan counseling at www.edfund.org

Selective service verification of enrollment at www.sss.gov

Apply for PIN at: www.pin.ed.gov

Did you know?

Gavilan College has a new Career Center Web Interface

Career Connections

Participation is free. Students can:

- ◆ Find full or part-time internship opportunities at <http://www.gavilan.edu/transferctr>
- ◆ Search for local job opportunities 24/7
- ◆ Schedule on-campus job interviews
- ◆ Manage multiple resumes, cover letters and other employment related documents

Employers can:

- ◆ post jobs
- ◆ Review resumes and student profiles
- ◆ Register for on-campus events such as Career Fairs
- ◆ and more!



Matriculation

ADMISSIONS • ASSESSMENT • ORIENTATION • COUNSELING • FOLLOW-UP

Matriculation is a series of services that Gavilan College commits to provide for you. The purpose is to help you identify your educational goals and successfully complete them.

Exemptions: Sometimes a student does not want to take advantage of the matriculation services. That is a right you have. In order to be exempt from assessment and orientation you must:

- have an AA degree or higher *or*
- have accumulated fewer than 12 units in transfer courses *or*
- be presently enrolled in fewer than six units *or*
- not plan to earn a certificate or degree.

Opt out by completing a waiver form at the Admissions & Records Office. Doing this will prevent you from participating in priority/early registration. You still have the right to use the other matriculation services. We encourage you to do so.

Assessment

Placement/assessment testing will help ensure that students are enrolled in courses that match their abilities in language and computational skills. Students must have completed the eighth grade to be eligible for assessment services. Placement scores, together with other indicators of a student's abilities, are used by counselors to recommend appropriate course placements. Register for the assessment at the Admissions & Records Office in the Student Center.

The assessment instruments used by Gavilan College for general assessment, the College Tests for English Placement (CTEP) and the Mathematics Diagnostic Testing Project (MDTP), are administered in English and are not intended for applicants to the English as a Second Language (ESL) program.

Sessions begin promptly at the stated time. Check in begins one half hour prior to starting time. No one will be admitted after the session has begun.

Assessment requires:

- Valid picture ID *
 - Social security number required for scoring of exam
 - The Assessment Center will provide pencils and pens for students during testing.
 - No pagers or cell phones allowed in the testing room
 - No watches allowed in the testing room.
- * A valid picture ID includes a California Driver's License, California ID, Passport, Student Body Card, Military ID or Alien Registration Card. Contact the Assessment Office (BU120B) or call 408-846-4992 if you do not have a valid ID.

Re-Assessment Sessions:

Students who have previously taken the assessment test may re-test after 30 days. You may re-assess once per semester. Stop by the Assessment Office (BU120B) or call 408-846-4992 to confirm dates, times and locations.

Re-Assessment requires a copy of the student's previous test scores (test scores can be obtained from the Counseling Secretary - SC113).

Times and locations are subject to change. Additional times may be added. (Confirm dates and locations with the Admissions and Records Office or check online posting at www.gavilan.edu/admit/assess.html.)

All new ESL students must go through the ESL assessment process. See page 134.

Todos los nuevos estudiantes de ESL deben tomar el examen de nivelación de ESL. Consulte la página 134.

Orientation

Orientation is a required component of matriculation. It provides new students with an overview of instructional programs, support services, facilities and general graduation requirements. Completion will help students avoid making course choices that might complicate and lengthen the time required to reach their educational goals. This is also a time for us to welcome you to Gavilan College and for you to have an opportunity to meet other new students and staff.

Students should participate in an orientation session prior to meeting with a counselor.

2008 In-Person Orientation Sessions: see ad on page 11.

Please phone 408-848-4723 for further details.

Orientation can also be completed online.

Click on the Orientation link on the Gavilan homepage - www.gavilan.edu to complete the orientation or contact the Counseling Office at 408-848-4723.

You may choose to not participate in orientation by completing a waiver form at the Admissions & Records Office. Doing this will prevent you from participating in priority (early) registration.

Counseling

Gavilan College provides a staff of full and part-time professional counselors to assist students in meeting educational, career and life goals. Counseling is available to students who are uncertain about their plans for the future, who are experiencing difficulty in making important decisions, or who have any other personal or social concerns. In addition, counselors make referrals to many community agencies. Students may seek the assistance of any counselor at Gavilan.

See a counselor when you are:

- a first time student planning to transfer
- a first time student planning to obtain a AA/AS degree
- an undecided major
- a high school contract student
- an academic probation student
- taking over 17.99 units (spring/fall) or over 5.99 units (summer)
- have completed prerequisite courses at another college(s)
- an international student with an "F" Visa

Photo ID and Gavilan Student ID required to obtain counseling services.

Summer Counseling Hours

Gavilan Main Campus (walk in)

May 27 - June 27 Mon-Thu, 8:00 am to 4:30 pm; Fridays, 8:00 - 11:30 am
 June 30 - July 4 *Counseling will be closed*
 July 7 - August 15 Mon-Thur, 8:00 am to 4:30 pm; Fridays, 8:00 - 11:30 am
 August 18 - 27 Mon-Thur, 8:00 am to 5:30 pm; Fridays, 8:00 - 11:30 am

Morgan Hill site:

June 4 Wed, 8:00 am to 4:00 pm
 June 11 Wed, 8:00 am to 4:00 pm
 June 16 Mon, 8:00 am to 4:00 pm
 Aug 6 Wed, 8:00 am to 4:00 pm
 Aug 12 Tues, 8:00 am to 4:00 pm
 Aug 13 Wed, 12:00 pm - 8:00 pm
 Aug 19 Tues, 12:00 pm - 8:00 pm
 Aug 20 Wed, 8:00 am to 4:00 pm
 Aug 27 Wed, 8:00 am to 4:00 pm

Hollister Briggs Building site:

June 3 Tues, 8:00 am to 4:00 pm
 June 10 Tues, 8:00 am to 4:00 pm
 June 12 Thur, 12:00 pm - 8:00 pm
 Aug 5 Tues, 8:00 am to 4:00 pm
 Aug 12 Tues, 12:00 pm - 8:00 pm
 Aug 19 Tues, 8:00 am to 4:00 pm
 Aug 20 Wed, 12:00 pm - 8:00 pm
 Aug 26 Tues, 8:00 am to 4:00 pm
 Aug 27 Wed, 12:00 pm - 8:00 pm

Fall Counseling Hours beginning Sept. 3

Gavilan Main Campus (walk in and appointments):

Walk -in: Mon-Fri 8:30 am-12:30 pm
 Appointments: Mon-Thur 8:30 am - 7:30 pm
 Fri 8:30 am - 3:30 pm

Morgan Hill site:

Wednesday services available. Call 408-782-2873 for an appointment.

Hollister Briggs Building site:

Tuesday and Wednesday services available. Call 831-636-3783 for an appointment.

Photo ID and Gavilan Student ID number are required to obtain counseling services.



Learn more about what the college offers: classes, degree programs, services, activities, what it will take to meet your goals and how to plan your Gavilan experience. Meet college counselors and fellow students and become familiar with the campus.

2008 In-Person Orientation Sessions: One Stop Shopping

Each orientation follows a placement/assessment testing session. Students who complete the orientation will have their test results available at the orientation and will be prepared to register for the fall semester.

* This does not apply to orientations given in Hollister.

- Saturday, May 10 11:30 am - 1:30 pm Main Campus
- Wednesday, May 28 12:00 pm - 2:00 pm Main Campus
- Wednesday, June 18 5:00 pm - 7:00 pm Main Campus
- Saturday, June 28 12:00 pm - 2:00 pm Main Campus
- Saturday, July 12 12:00 pm - 2:00 pm Main Campus
- Tuesday, July 15 6:00 pm - 8:00 pm Main Campus
- Thursday, August 14 12:00 pm - 2:00 pm Main Campus
- Wednesday, August 20 6:00 pm - 8:00 pm Hollister*
- Saturday, August 23 11:30 am - 1:30 pm Main Campus

Call **408-848-4723** for details.

Counselors by Department and Program To schedule an appointment call the Counseling Secretary: 408-848-4723 or visit SC 113.

Dr. Jesus Olivas, <i>General Counseling/Articulation</i>	SC104
Dr. Rosa Sharboneau, <i>General Counseling/Transfer</i>	SC119
Dr. Tim Lister, <i>General Counseling</i>	SC106
Alex Lopez, <i>General Counseling</i>	SC107
Celia Marquez, <i>General Counseling/Puente Program</i>	SC105
Jane Godley, <i>General Counseling</i>	SC107
Johanna Stewart, <i>General Counseling, ASB</i>	SC107b
Leslie Tenney, <i>General Counseling</i>	SC103
<u>Athletics:</u> Darlene Del Carmen	848-4880 GY118

<u>Basic Skills:</u>	846-4820	Library
<u>DRC (Disability Resource Center):</u>		
Bruce Eastman	848-4865	L1117
<u>EOPS/CalWORKs (Extended Opportunity Programs and Services):</u>		
Blanca Arteaga	848-4747	L1101a
<u>MESA:</u> Marilyn Chavez	848-4800, ext. 5606	PB15
<u>TRIO:</u> Leticia Palacios	848-4707	SC161

High School Students Concurrent Enrollment

Registration Checklist

- #1 Apply.** File at least two working days before registering. Go to www.gavilan.edu and click on the link for Gavilan's online application.
- #2 Schedule and take an assessment placement test.** Sign up in person or call 408-846-4954 or 408-846-4992.
- #3 See your high school counselor.** Take your assessment test results and discuss possible courses. The course your counselor writes on the Special Student Status Contract Form is the course for which you will be enrolled, space permitting. Be sure the counselor signs your contract form. Directions to obtain the contract are listed in the concurrent enrollment section on this page.
- #4 Get a copy of your current high school transcript** from the Registrar at your high school and attach it to your contract form. The transcript must show that you are in good standing and that you have a grade point average of at least 2.00.
- #5 Ask your parent or guardian to sign the contract.**
- #6 Bring your transcript and signed contract** to a Gavilan College counselor during the enrollment period for high school students.
- #7 Register for Gavilan classes.**
 - Enroll for a maximum of 6 semester units of transfer level courses during the fall and spring semesters or for 5 units of pre-collegiate or transfer courses during the summer term (certain exceptions may be available for students enrolled in the TJ Owens Early College Academy)
 - Purchase a parking permit if you need one
 - Buy your books at the bookstore
- #8 Enjoy your class!** You're earning college credit.

For more information, see the concurrent enrollment section (this page).

If you are enrolling in a High Step class, some steps may be facilitated by Gavilan College staff on your behalf.

High School Students

Concurrent Enrollment Procedures

Students whose age or class level is equal to grades 9 - 12 may attend Gavilan College as part-time or summer session students for advanced scholastic, vocational, or physical educational courses in accordance with the following procedures:

A **Special Student Status Contract Form** is required prior to registering for classes. A new form must be completed each semester. The form is available in local high school counseling offices, from the Gavilan College Admissions & Records Office and is included at the back of this schedule. The form is also available online at http://www.gavilan.edu/admit/sp2006_high_school.pdf

Students enrolled in a public or private high school will be limited to a maximum of 6 units for fall or spring semesters and 5 during the summer term (certain exceptions may be available for students enrolled in the TJ Owens Early College Academy). Students in good standing, with a minimum 2.0 GPA, must submit a current transcript, complete the placement assessment, and have the written approval of a parent or legal guardian, a high school counselor or principal and a Gavilan College counselor.

The campus center use fee, health fee, and student representation fee are waived for concurrently enrolled high school students.

Your Gavilan College Counseling Appointment

High school students must review their completed contract with a Gavilan College counselor. Counseling Services are available at the Gavilan main campus. See counseling hours (page 11) for dates and times.

Use the Registration Checklist (this page) to prepare for your meeting. For more information, call the Counseling secretary: 408-848-4723. A photo ID is required to obtain counseling services.

High Step students: Please refer to instructions for High Step students on page 14.

High School students may enroll in the following:

(All prerequisites apply)

- Fall and Spring Semesters: **Transfer level (courses numbered 1-99)**
- Summer Session: **All courses (transfer and non-transfer level)**

PLEASE NOTE: Additional rules may apply for students enrolled in the Dr. TJ Owens Gilroy Early College Academy (GECA)



The **College Catalog** contains a complete description of all Gavilan College courses, student policies, and services. It can be purchased for \$4.00 at the bookstore or viewed online at www.gavilan.edu/catalog

Attend High School at Gavilan College!



“Be Someone. Go Somewhere. Seek Excellence.”

The Dr. TJ Owens Gilroy Early College Academy (GECA) at Gavilan College is an innovative, challenging, and highly supportive academically accelerated high school program designed to serve strongly motivated students with high potential for future academic and career success.

The Academy is an educational partnership between Gilroy Unified School District and Gavilan College, and is one of the cutting-edge Early College High Schools that are being envisioned and funded all across the United States through the Bill and Melinda Gates Foundation in cooperation with local community colleges and school districts.

Acceptance to the Academy is based on a multiple-measures approach that involves an application packet, essay, personal interview, and Gavilan College assessment testing in both English and Mathematics. Applicants are not required to either be currently enrolled in a Gilroy Unified school or live in the Gilroy Unified District, but should have an overall GPA of 2.5 – 4.0, STAR scores in the “Proficient” range or above, and the ability to read at, or above, the 9th grade level.

If you are selected to attend, your four years of high school will be spent at the Academy, which is located on the Gavilan College campus. You and your fellow students will experience a highly rigorous, college preparatory (Honors and AP) high school education, as well as take fully transferable college classes (up to 11 units a semester), for which you will receive both college and high school credit! Graduation in four years will see you move on to a four-year university with two full years of college (60 units) completed and paid for in full! In the process, many of our students will earn one – or more – AA or AS degrees from Gavilan.

There is no cost to parents or students for this remarkable program, as all tuition is waived by Gavilan and all books are provided by the Academy. Applications are available online at www.gavilan.edu/geca, at any of the GUSD Middle Schools, or at the GECA office at Gavilan. A freshmen class of 100 students (currently in 8th grade) and 30 new sophomore students (currently in 9th grade) will be selected by Monday, March 10, 2008. For more information, contact Mr. Michael Hall, Principal of GECA by email at mhall@gavilan.edu, by phone at 408.846.4909 or visit www.gavilan.edu/geca.

All records of high school students attending Gavilan are protected by the Federal Educational Rights and Privacy Act (FERPA) and may not be released to anyone without the written permission of the student.

Course-to-Course Articulation Agreements* for High School Students

Gavilan College and District High Schools:

High School Course	Gavilan College Criteria	Grade
--------------------	--------------------------	-------

Anzar High School - Aromas / San Juan Bautista

Algebra	Math 205	A or B
Advanced Algebra	Math 233	A or B

Gilroy High School

Integrated Algebra 1 & 2	Math 205	A or B
Integrated Algebra 2 & 3	Math 233	A or B
Law Enforcement	AJ 10	A or B

Live Oak High School - Morgan Hill

Computer Aided Drafting-ROP	CGD2 & CGD2R	C or better
Child Care-ROP	Child Develop. 1, 21	A or B
Algebra I	Math 205	A or B
Algebra II	Math 233	A or B

Mt. Madonna High School - Continuation High School Gilroy

Algebra I	Math 205	A or B
-----------	----------	--------

San Benito High School - Hollister

Computer Accounting	ACCT 103	C or better
Computer Aided Drafting-ROP	CGD2 & CGD2R	C or better
Careers with Children-ROP	Child Develop 21	A or B
Algebra 1A or Algebra II	Math 205	A or B
Algebra 2A	Math 233	A or B

*Articulation agreements currently being reviewed. Check Admissions for further information



Seniors! Plan ahead!

- Take the assessment and register by May 14th!
- Placed in English 250 and want to transfer? Puente may be for you.
- Learn about Mexican American/Latino Literature.
- College visits in fall/spring.
- Attend a Leadership Conference.
- Receive extra support from a community mentor.
- On-going academic, career and personal counseling until you transfer!

Meet with Puente Counselor/Coordinator Celia Marquez.
Call 408-848-4723 to schedule an appointment.

EOPS

MAKING DREAMS REALITY

Extended Opportunities Programs and Services



provides an accessible and rewarding college experience to low-income students facing social, economic and educational disadvantages.

You may be eligible for the following services:

- * Grant Money
- * Priority Registration
- * Counselling
- * Book Vouchers
- * Book Lending Library and many other services

408-848-4740
Rms. L101A & L101B



HIGH STEP PROGRAM

High School Transfer Enrichment

Gavilan College, in conjunction with Gilroy High School will offer courses accepted at any university (such as Political Science/Government and US History 1 and 2) each spring and fall semester at the high school campuses. All students are required to take the placement assessment prior to enrolling. All concurrent enrollment documents are required.

Please contact the Gavilan Assessment Office at 408-848-4992 or your high school counselor for more information and for a schedule of the placement assessment offered at the high school campuses.

The Program:

- Start college while enrolled in High School!
- In two years earn a maximum of 12 college units.
- Courses conveniently offered at the high school.
- Meet college and university requirements while still in high school.

The Benefits:

- It's FREE! The enrollment fee, campus center use fee, health fee and student representation fee are waived for High Step students.
- Experience college level work.
- Reduce four-year university expense.
- Advance academically.
- Become competitive in the four-year college and university admission process.

Who Can Participate?

- High School Juniors and Seniors (Courses offered at high school locations are open to any college-age student.)
- Minimum cumulative 2.0 GPA.
- Score at college level in reading, writing, and math.
- Ability to benefit from advanced scholastic work.

How to Register:

1. Take the Gavilan College assessment placement on your campus, at the Gavilan College Gilroy main campus or at the Morgan Hill or Hollister sites. You will complete a Gavilan application for admission during your assessment. Check out the assessment schedule on the web at www.gavilan.edu/admit/assess.html.
2. See your high school counselor or academic coordinator to determine eligibility and complete a Recommendation for Special Student Status form (High School Contract). All concurrent enrollment documents are required.
3. Ask your parent to sign the contract.
4. Turn all paperwork in to your high school counselor or academic coordinator.

Students must purchase their own textbooks. Check out the Gavilan College bookstore website at www.gavilan.bkstr.com. **Financial assistance may be available** for textbooks. See your high school counselor or academic coordinator for more information.

Fall 2008 High Step classes offered at:

Gilroy High School: See class listings for course descriptions.

CSIS 1	Computer Literacy - MS Office	CRF # 10445	Gilroy (Room D-1)	Tuesday	3:30 - 6:30 pm	Dates: 11/9 -11/25
PHIL 6A	Comparative Religions	CRF # 10729	Gilroy (Room BE-3)	Tuesday	3:30 - 6:35 pm	Dates: 9/9 -12/20

San Benito High School: See class listings for course descriptions.

GUID 1	Self-Assessment & Career Dev.	CRF # 10013	San Benito High (Room 194)	Monday	3:15 - 5:20 pm	Dates: 9/8 -12/20
PSYC 5	Self-Assessment & Career Dev.	CRF # 10014	San Benito High (Room 194)	Monday	3:15 - 5:20 pm	Dates: 9/8 -12/20

Room assignments subject to change. Please call 408-846-4967 to confirm the room.

Recommended Math Course Placements For Area High School Students

Gilroy High School

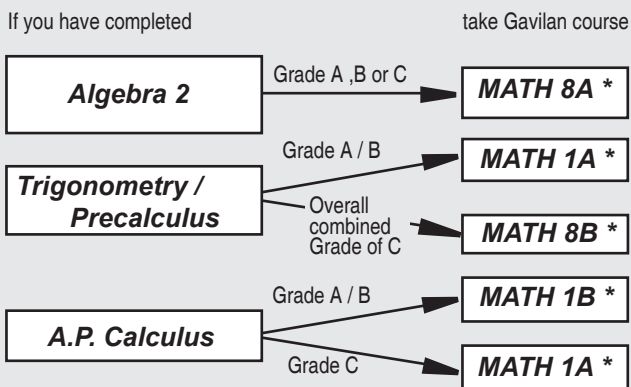

San Benito High School

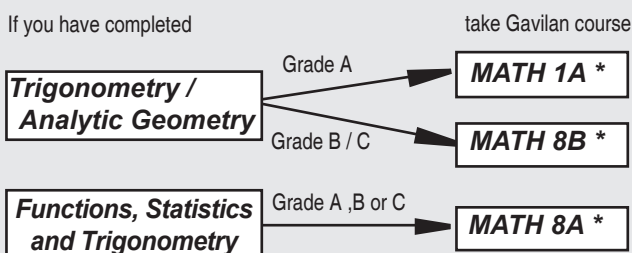

Anzar High School

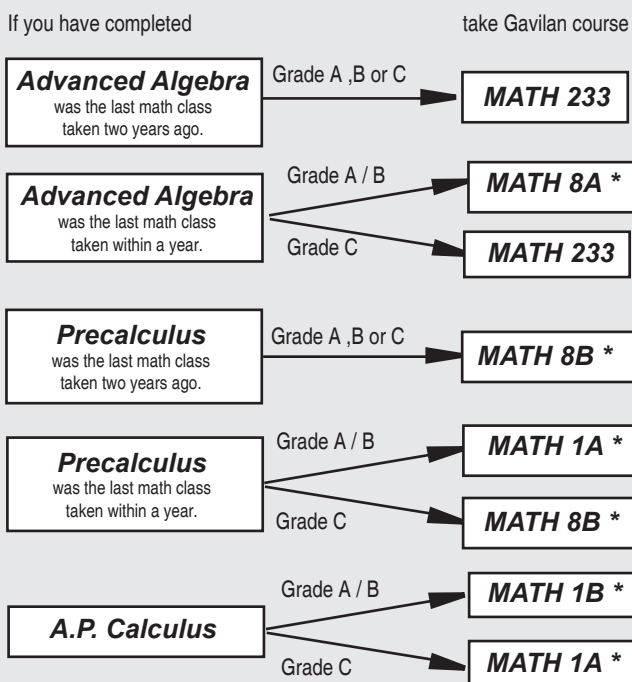

Live Oak High School

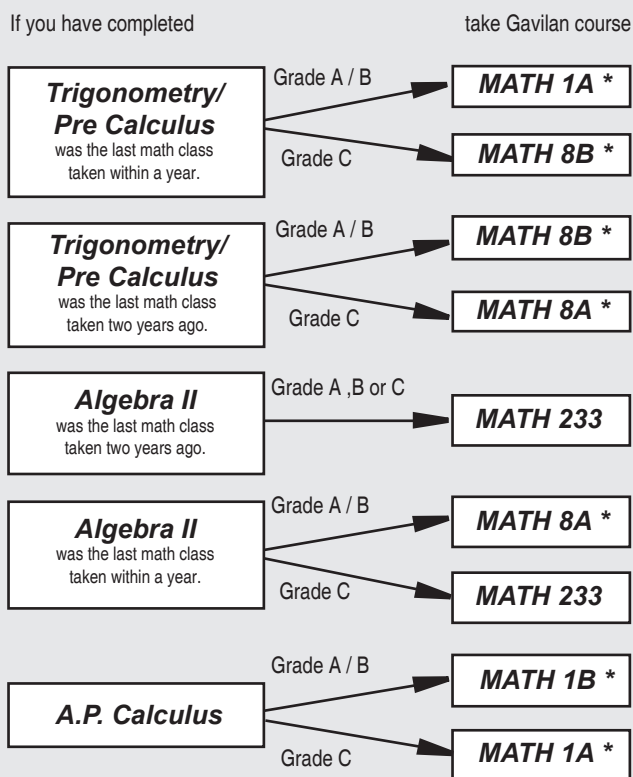

Multiple measures will be considered to determine your final course placement. Consult with a counselor to select the appropriate course.

* Students eligible for these courses are also eligible for Math 5, 6, 7, 12 and 14.

After School is Out...



Take a Class at GAVILAN!

Receive college credit.

Gavilan offers a selection of afternoon & evening classes at our three locations and selected high school campuses.



What is it? The Transfer Institute (TI) is a Gavilan College program to guide you through the transfer process in the most efficient and effective means possible. As a part of the Transfer Institute you will save time and money by completing your freshman and sophomore years at Gavilan. You will also meet and get to know other students who share your goals and ambition.

Who is eligible?

- Recent high school graduates who are academically prepared for college level work.
- Students with placement in *college level English & math*.

How do I apply?

- 1.** Complete a Transfer Institute application in May prior to high school graduation.
- 2.** Take a Gavilan College placement test.
- 3.** Complete a Gavilan College admissions application and
- 4.** Submit a High School transcript.

Limited spaces are available - apply early!

Benefits - Transfer Institute students receive:

- Early Registration.
- A dedicated counselor to guide and monitor you through the transfer process.
- Pre-transfer events and activities with four-year universities.
- Access to activities designed to ensure your success at Gavilan College.
- Assistance with the identification of and preparation for a college major.
- A two-year agreement guaranteeing your transfer goals.

Services - Your success is dependent on your attendance in enrolled classes, completion of course assignments and participation in Transfer Institute support services.

The following are some of the many Transfer Institute services available that will ensure your academic and transfer success:

- Development of your personal TI agreement that identifies academic services, support services and activities essential to your transfer planning and success.
- Development of an individual Educational Plan by trained and knowledgeable counseling faculty that charts courses needed for completion of general education and major preparation.
- Eligibility assistance with all participating TAA's (Transfer Admissions Agreements.)
- Assistance with finding sources of financial aid and educational financial planning.
- Semester-by-semester feedback on transfer progress.
- Early connections with university admission representatives.
- Opportunities to participate in university visits.
- Transfer information updates and event announcements to keep you connected with and prepared for the university experience.
- Workshops to assist with the transfer process.
- Assistance with completing your transfer applications.
- Documented evaluation of courses completed at other colleges that transfer to and satisfy university requirements.



Applications for the fall 2008 Transfer Institute will be accepted beginning in April 2008.

For more information, call (408) 848-4723 or visit the website at www.gavilan.edu/transfer

A Transfer Institute application is printed on the last page of this Schedule of Classes.

GAVILAN COLLEGE

2007 Report To the Community of the Measure E Citizens' Oversight Committee

About Measure E

On March 2, 2004, district voters approved Measure E, a \$108 million facilities improvement bond measure that will upgrade and expand the facilities for higher education in the Gavilan Joint Community College District. Upgrades will be made to outdated plumbing and wiring, renovate aging classrooms and libraries, provide access for disabled students, improve campus safety, and plan for the future by acquiring land for permanent facilities in San Benito County and the greater Morgan Hill / Coyote Valley.

Role of the Citizens' Oversight Committee

The purpose of the Measure E Citizens' Oversight Committee is to review and report on the expenditure of taxpayers' money for construction, inform the public about the expenditure of bond revenues, and to advise the public as to the district's compliance with the California Constitution and Measure E. The Oversight Committee holds open meetings to review and discuss updates on projects funded by Measure E. The Oversight Committee may: inspect school facilities and grounds to ensure that bond revenues are expended properly, receive and review copies of any deferred maintenance proposals or plans developed by the Gavilan Joint Community College District, and review efforts by the district to maximize bond revenues by implementing cost-saving measures.



Citizens' Oversight Committee Members

Committee Chair: Pi Silverstein

Committee Vice Chair: Douglas Marshall

At-large Representatives: Thomas Andrade, Tony Ko,
Marco Renella

Business Organization Representatives:

David Boll, Lawrence J. Grace

Representative of a college support organization:

Douglas Marshall

Senior Citizens Organization Representative: Pi Silverstein

Students active in a college support group: vacant

Tax Payer's Organization Representative: Mark Zappa

Phase I of improvements to campus lighting provided new light poles along Sycamore Lane, along the Campus Loop Road, adjacent to the theater, at the bus stop, and in Parking Lot A, improving safety and access for night students.

Contact

Meeting dates, agendas, and minutes of past meetings can be found at the website: www.gavilan.edu/bond. For more information or to contact the committee call (408) 848-4711.

Estimated Master Schedule and Project Timeline

YEARS	PLANNED PROJECTS
2006-2008	Physical Science, Chemistry, Life Science, Occupational Education Phase 1
2007-2009	Humanities, Art, Music Hall
2008-2010	Cosmetology, Business, Maintenance/Security
2009-2011	Social Science, Gymnasium*
2010-2012	Library*
2011-2013	Student Center*
2012-2014	Occupational Education Phase 2, Parking Lots

* items with asterisks may be moved forward if state funding becomes available

Conceptual drawing showing planned improvements to parking lots and landscaping on the Gilroy campus

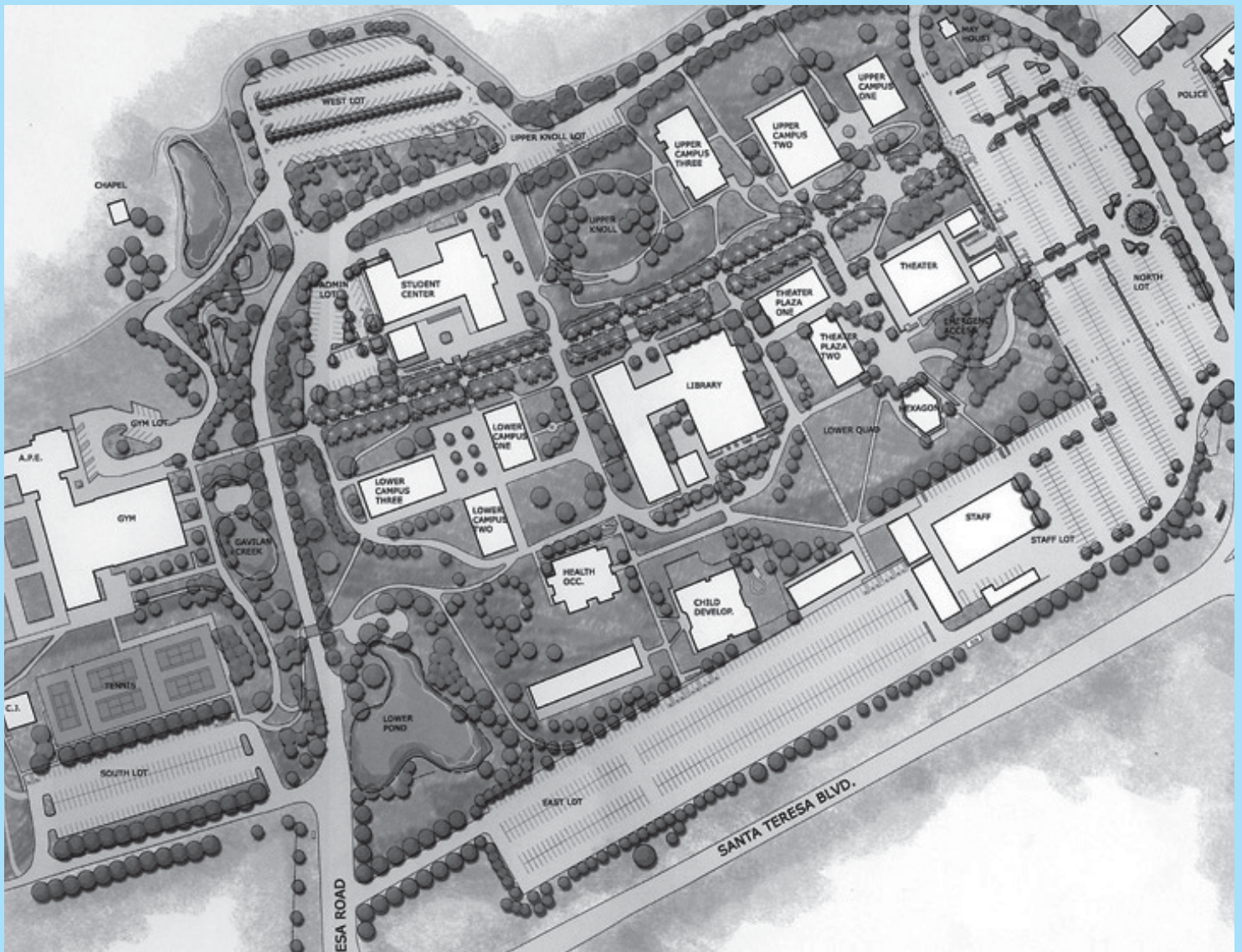

Status of Measure E projects Through 12/31/07

MAIN CAMPUS

Tennis court repairs	Completed ✓
Boiler replacement	Completed ✓
ADA transition planning	Completed ✓
Infrastructure replacement	Completed ✓
Interim Housing installation	Completed ✓
Instructional facilities repair	In progress
Parking Lot improvements	
Phase 1	Completed ✓
Phase 2	In progress
Lighting improvements	
Phase 1	Completed ✓
Phase 2	In progress

TECHNOLOGY UPGRADES

Computer replacement	Completed ✓
Enterprise Resource System	In progress

COYOTE VALLEY

Land acquisition	In progress
------------------	-------------

SAN BENITO COUNTY

Land acquisition	In progress
------------------	-------------

Coyote Valley Draft EIR and monthly Construction Updates are available online at www.gavilan.edu/bond

Letter from the Chair

What a difference a year makes. Last year, the first beyond the initial planning stages, only the Tennis Court repairs, boiler replacement and ADA transition planning were completed. This year, several major projects were completed, more were under construction, and some were being planned. An example of a completed project that has had a big effect on the campus is the lighting. For those of you who have visited the Gilroy Campus, and especially those who have attended night classes, safety was a concern. It is much safer now. And night time attendance is up. The parking lot improvements have been welcomed by all of the students, and more such improvements are coming. It is also important that the Board of Trustees has assured the Committee and the Faculty that all projects will be completed. As some projects are not going to start for several years, it is comforting to know those at the end of the line are as important as those already completed.

Two big projects have moved along that will affect San Benito County and the Greater Morgan Hill/ Coyote Valley areas. Property in Hollister has been located for a new campus at the corner of Fairview and Hwy. 25. The site for Coyote Valley is across from what I call "the IBM think tank" on Bailey, west of Santa Teresa Blvd.

The Citizens Oversight Committee takes its role seriously. Though legally we only have to meet once a year to review audits and prepare this Report, since its beginning we have generally met 4 times a year. In between meetings, the Administration provides the Committee all of the Measure E information that is provided to the Board of Trustees as well as scheduling presentations by the consultants who manage the construction. The Auditors made presentations to the Committee and were available for questions from the Committee members. Only following those presentations and approval by the Committee do the Auditor's Reports go to the Board of Trustees.

I would like to thank the following Committee members who have completed their terms: Russ Danielson and Sandra Fishler. To the current members, I must say they have the best interest of the public in mind and have worked well as the eyes of the public overseeing the use of the \$108, 000,000 Measure E Bond. And last but not least, thanks to the Administration and their consultants for their support of the Oversight Committee, especially Dr. Steve Kinsella, Joe Keeler, and Suzanne Bulle of the Administration and Casey Michaelis of Kitchell CEM.

Pi Silverstein, Chair
Citizen's Oversight Committee



Heating and Air Conditioning improvements are included in the renovations to the Science Buildings now underway.

Expenditures for the fiscal year 2007:

Classified Salaries*	\$	43,829
Employee Benefits*		16,888
Services/Operating Expenditures		10,025,093
Capital Outlay		3,319,073
<hr/>		
Total expenditures	\$	13,404,883

* Salaries and benefits are for non-administrative employees directly involved in the implementation of Measure E

Bond Issuance

25-year general obligation bonds have been issued as follows:

Issue Date	Maturity Date	Interest Rate	Redeemed	Outstanding
6/10/04	8/1/2028	2.0 - 5.0%	\$ 1,040,000	\$ 27,470,000
6/10/04	8/1/2006	3.0 - 3.5%	\$ 425,000	\$ --

**an additional \$50,000,000 were issued in January, 2008

Debt Service Requirements

Year	Principal	Interest	Total
2008	1,625,000	1,370,063	2,995,063
2009	135,000	1,321,313	1,456,313
2010	195,000	1,317,263	1,512,263
2011	265,000	1,310,681	1,575,681
2012	335,000	1,301,738	1,636,738
2013-2017	2,990,000	6,242,950	9,232,950
2018-2022	5,885,000	5,310,895	11,195,895
2023-2027	10,265,000	3,345,675	13,610,675
2027-2029	5,775,000	484,000	6,259,000
<hr/>			
Total	\$ 27,470,000	\$ 22,004,578	\$ 49,474,578

Independent Financial Audit

An independent financial audit is conducted annually. The audit was completed by Vavrinek, Trine, Day & Co., LLP of Pleasanton, California and a report issued in November, 2007. The audit concluded that the financial statements of the Bond construction fund fairly present the financial position and changes in the Measure E fund balance, in accordance with accounting principles generally accepted in the United States.

Conclusions

The Measure E Citizens' Oversight Committee finds that Gavilan College has complied with the spirit and requirements of state law, and the commitment made to the voters in accounting for and expending public bond funds. Gavilan College has exercised appropriate fiscal discretion in selecting best practices designed to facilitate projects through planning and contract management.

The District used a Financial Adviser to provide an independent view of pricing conditions at the time the bonds were sold. The adviser recognized a shift in interest rates was occurring and recommended the college wait one additional day prior to issuing the bonds. The Financial Adviser's recommendation saved taxpayers \$3 million as market conditions changed which resulted in a lower interest rate on the bonds. The lower rate generated a savings of \$3 million.



Science classrooms are undergoing complete renovation, including new furnishings.



Summer Session

June 16 - July 25, 2008

SIX-WEEK SUMMER SESSION CLASSES BEGIN

Check the class listings for classes beginning earlier and later.

Mon, June 16

LAST DAY TO ADD A CLASS

Unless course is on the Open Entry List or is late-starting.

**Tues, June 17 in person until 6 pm
online until 10 pm**

REFUND DEADLINE

For term-long courses.

Fri, June 20

"NRS" DEADLINE

"No Record Shown". Courses dropped by this date do not appear on the student's permanent record.

Thurs, June 26

DEADLINE FOR GRADING OPTION

Last day to elect the Pass/No Pass grading option for designated, term-long courses. See Admissions & Records for more information.

Thurs, June 26

INDEPENDENCE DAY HOLIDAY

No day or evening classes.

Fri, July 4

"W" DEADLINE

Courses dropped by this date appear on the student's permanent record with a notation of "W" for withdrawn.

Fri, July 18

FINAL EXAMS

Last day of each class

LAST DAY OF CLASSES

Fri, July 25

Unofficial GRADES

available online

Mon, Aug 4

Official TRANSCRIPTS available

available online at Self-Service Banner

Sun, Aug 17



What is Summer Bridge?

This program provides a transition from high school to college and develops academic skills needed for college success. The ultimate goal is to provide the tools that will help students stay, graduate and/or transfer from Gavilan College.

Who is Eligible?

- In order to be eligible you must be:
- Low income, according to federal financial criteria and/or a first generation college student (meaning neither parent has earned a college degree) or
 - A student with a verified disability.

What are the benefits?

- Earn 5 college credits. Enroll in two college courses:
CMUN 10 - Small Group Communications
GUID 200 - Planning College Success
- Receive academic support.
- Make new friends.

How do you apply?

- Apply to Gavilan College for Summer 2008.
- Take the Gavilan College Assessment Test.
- Apply for Financial Aid (FAFSA).
- Apply for the Board of Governors Fee Waiver.
- Return your Summer Bridge Application to your high school counselor or mail to: TRIO Program
Gavilan Community College
5055 Santa Teresa Blvd.
Gilroy, CA 95020.

For more information:
call (408) 846-4981

June 16 - July 24

Counseling Services

are available at the Gavilan main campus on a first-come, first-served basis (walk-ins) beginning May 27. See page 11 for dates and times.

For more information, call the Counseling secretary: 408-848-4723.
Photo ID and Gavilan Student ID are number required to obtain counseling services.

Use the
**Registration Checklist on
the first page of this schedule to
prepare for your meeting.**

ADD CODES: To add a closed (filled) class once the term has begun, students must obtain an "add code" from the instructor. The "add code" is a four-digit code to be used to register either in person or online. Students may obtain an add code from the instructor before or after the class meeting or during the instructor's office hours.

SUMMER SESSION 2008 REGISTRATION

Students must be registered before the first day of an early-start or late-start class.

APPLY ONLINE

File at least two working days before registering. Go to www.gavilan.edu and click on the link for Gavilan's online application.

REGISTER ONLINE

Go to www.gavilan.edu and click on the Self-Service Banner icon.

New and returning students must have an application on file two working days prior to registering. To register go to www.gavilan.edu and click on the Self-Service Banner icon to get your Gavilan Student ID number and select a user ID and PIN. Register!

High School students register in person.

Add code required for filled (closed) classes once classes have begun.

Helpline available during in-person registration hours @ 408-848-4733.

REGISTRATION SCHEDULE

• CONTINUING STUDENTS

May 5 – June 15

• NEW OR RETURNING STUDENTS

May 12 – June 15

• REGISTRATION FOR HIGH SCHOOL CONTRACT STUDENTS *in grades 9 through 12*

May 12 – June 13 or during late registration

High School contract students must register in person.

• LATE REGISTRATION for the 6-week Summer Session beginning June 16

New, Returning or Continuing or High School Contract Students:
June 16 & 17

Students must be registered by the end of the second day of the term for any six-week class. An add code (issued by the instructor) is required to register for any closed (full) class.

Refunds: Refunds of the enrollment fee, Health Services fee, parking fee and/or other fees are not automatic. To receive a refund for a term-long course, even for a cancelled course, the student is required to file a Petition for Refund form, available from the Admissions and Records Office. 100% of the enrollment fee minus a \$10 processing fee will be refunded if term-long courses are officially dropped by Friday, June 20 and a Request for Refund form filed no later than noon on June 27. No refunds will be given for requests made after this date. Parking Permits must be returned to receive a refund of parking fees.

Short-term courses must be dropped before 10% of the class meetings have passed.

Adding Courses Students may add courses to their schedules until the end of the second day of the six-week term contingent upon seat availability. To add a course once the course is filled (closed), an add code is required.

Students adding courses with a start date earlier or later than June 18 must be registered by the first day of the class.

Dropping Courses Students may drop courses online at Self-Service Banner or in person. A student who stops attending and does not officially withdraw is not automatically dropped and may receive a final grade of "F" or "NC".

Six-week courses dropped by Thursday, June 26 will not appear on the student's permanent record. Classes dropped between June 27 and July 18 will appear on the permanent record with a notation of "W" (withdrawn).

The "W" deadline for all courses is 75% of the class meetings.

Parking Student spaces are enforced Monday through Thursday from 7 a.m. to 10 p.m. and Friday from 7 a.m. to 5 p.m. Student parking is permitted in Lots A, C, E or H except where restricted to staff, visitors or handicapped. All vehicles parked on campus must display a parking permit. Day tickets are available for 75 cents at coin-operated machines in parking lots A & E and at the south entrance to campus. All-day permits for the four or six-week Summer Session are \$20 and are available from the Admissions and Records Office.

REGISTER IN PERSON

MAIN CAMPUS

May 5 – 30 Mon-Thurs, 8 am - 4:30 pm; Fri, 9 am - 4:30 pm

Note: No in-person registration on Monday, May 26 (Memorial Day Holiday)

June 2 – June 13 Mon-Thurs, 8 am – 5 pm; Fri, 9 am – 11:30 am

June 16 & 17 Mon, Tues, 8 am – 6 pm

MORGAN HILL AND HOLLISTER SITES

May 5 – 22 Mon-Thurs: 8 am - 8 pm, Fri: 8 am - 5 pm

May 27 – June 13 Mon-Thurs: 8 am - 5:30 pm, Fri: 8 am - 12 noon

June 16 – June 25 Mon-Thurs. 8 am - 8 pm; Fri. 8 am - 12 noon

Notes: *Sites are open on Fridays beginning May 30 from 8 am to 12 noon.
May 23 – Closed for Graduation
May 26 – Closed for Memorial Day*



Pay in person with credit card or electronic check at the Admissions & Records office or at either site or by calling toll-free 1-866-255-1801.

American Express, Mastercard, Visa or Discover accepted.

Basic Fees

- Health Fee \$5
- Student Representation Fee \$1
- Per unit fee (California resident)..... \$20
- Per unit fee (Non-resident) \$204
- Parking Permits (Required only on the Gilroy campus):
- Day Permit (7 am - 10 pm) \$20

Enrollment Fees *Pay online or in person with American Express, Mastercard, Visa or Discover.*

Gavilan College is a public institution; the only costs to a California resident are the registration fees, books, and supplies.

# of Units	Total* California Resident	Total* Non-Resident	# of Units	Total* California Resident	Total* Non-Resident
0.5	32.50	125.00	3.5	95.50	737.00
1.0	43.00	227.00	4.0	106.00	839.00
1.5	53.50	329.00	4.5	116.50	941.00
2.0	64.00	431.00	5.0	127.00	1043.00
2.5	74.50	533.00	5.5	137.00	1144.50
3.0	85.00	635.00	6.0	147.00	1246.00

* All students pay a \$1 Student Representation Fee and a Health Fee of \$5. The above schedule includes these fees.

Non-resident students: There is a tuition charge of \$184 per unit in addition to the \$20 per unit enrollment fee, health fee and student representation fee.

Registration Payment Deadline Schedule

Payment must be received and/or posted on or before the deadline listed to avoid being deregistered from the class.

Register Between	Payment Deadline
Tues, April 29 - Sun, May 4	Sunday, May 4 at midnight
Mon, May 5 - Sun, May 11	Sunday, May 11 at midnight
Mon, May 12 - Sun, May 25	Sunday, May 25 at midnight
Mon, May 26 - Sun, June 8	Sunday, June 8 at midnight
Mon, June 9 - Sun, June 15	Sunday, June 15 at midnight
Mon, June 16	Monday, June 16 at midnight
Tues, June 17	Tuesday, June 17 at midnight

Need a Book Loan?

With an ASB card you can apply for an ASB book loan (up to \$300) at the Financial Aid Office, room SC124.

Buy an ASB card at the Admissions & Records Office, room SC111.



What is a CRN?

CRN stands for Course Reference Number. This is the number (used to be called section) that you will use to register for your classes.

Beginning with the summer 2008 enrollment period social security numbers will no longer be used as student identifiers. Find your new Gavilan Student ID and choose a PIN by going to www.gavilan.edu and clicking on the Self-Service Banner icon. You will use your new ID and PIN to log into Self-Service Banner and register for summer and fall classes.

Gavilan College is an on-site partner in the

ONE-STOP CAREER CENTER

Job and Career Services
Open to the Public



831-637-JOBS (Hollister)
www.sbcjobs.org

SUMMER SPORTS CAMPS FOR KIDS!

See ad on page 38.



Summer Distance Education Courses

Online



Online courses allow students who have access to a computer with Internet connection to take college credit classes. Students need to have access to a computer, to an individual email account and to the World Wide Web. Students enrolled in these Internet-delivered classes will meet with their instructors and with their classmates through the Internet. The majority of coursework is done online. However, one or more on-campus meetings may be required. If this is a problem, you may contact your instructor for possible accommodations.

After enrolling online, start the class by going to <http://www.gavilan.edu/disted/>

It is your responsibility to log into your class during the first week of class.

BE SURE TO NOTE THE STARTING DATE. Students who have not logged into their class by the end of the first week could be dropped from the class. For more information please see the distance education page at <http://www.gavilan.edu/disted/>

Orientations: We strongly recommend that students take one of the live orientations to online courses offered in the Gavilan Library. Please see the library homepage at: <http://www.gavilan.edu/library/> for a schedule of orientations or you may make a personal appointment with one of the librarians by calling 408-848-4806.

CRN	COURSE #	TITLE	BEGIN/END	INSTRUCTOR	CRN	COURSE #	TITLE	BEGIN/END	INSTRUCTOR
80210	AH 11	NUTRITION	6/16 7/25	Martha Akrop	80249	CSIS 128	DATABASE-MS ACCESS	6/16 7/21	Ellen Venable
80184	ANTH 1	INTRO PHYSICAL ANTH	6/16 7/25	Debra Klein	80152	CSIS 151	INTRO XML AUTHOR	6/16 8/8	Dennie Van Tassel
80179	ANTH 1	INTRO PHYSICAL ANTH	6/16 7/25	Dennis Etlar	80004	ENGL 1A	COMPOSITION	6/16 7/25	Erin Crook
80061	ART 6	ART APPRECIATION	6/16 7/25	Jane Edberg	80011	ENGL 1A	COMPOSITION	6/16 7/25	Erin Crook
80059	ART 6	ART APPRECIATION	6/16 7/25	Jane Edberg	80021	ENGL 1B	COMPOSITION & LIT	6/16 8/8	Kyle Hull
80211	BIO 11	NUTRITION	6/16 7/25	Martha Akrop	80024	ENGL 1B	COMPOSITION & LIT	6/16 8/8	Jennifer Raimondo
80223	CD 2	EARLY CHILD DEVELOP	6/16 7/25	Marlene Bumgarner	80027	ENGL 1C	CRITIC REASON/WRITE	6/16 7/25	Xochiqueta Candelaria
80226	CD 3	CHILD GROWTH/DEV	6/16 7/25	Marlene Bumgarner	80020	GUID 1	SELF ASSESSMENT	6/16 7/25	Johanna Stewart
80233	CD 16	EXPLO MATH W/CHLDRN	6/16 7/25	Dionne Clabaugh	80006	GUID 1	SELF ASSESSMENT	6/16 7/25	Rosa Sharboneau
80256	CD 17	EXPLOR SCIENCE/CHLD	6/16 7/25	Dionne Clabaugh	80036	GUID 6	LIFE SKILLS HIGHER ED	6/16 7/25	Celia Marquez
80134	CSIS 3	RESEARCH SKILLS	6/16 8/8	Dana Young	80133	LIB 3	RESEARCH SKILLS	6/16 8/8	Dana Young
80038	CSIS 8	INTRO TO INTERNET	6/16 7/25	Ellen Venable	80263	LIB 732 * **	INTRO TO ONLINE GAVILAN	6/9 7/25	Joy Parker
80253	CSIS 12	ASSEMBLY LANGUAGE	7/7 8/28	Dennie Van Tassel	80196	POLS 1	INTRO AMERICAN GOVERNMENT	6/16 7/25	Mark Turetzky
80180	CSIS 12	ASSEMBLY LANGUAGE	6/16 8/8	Dennie Van Tassel	80195	POLS 1	INTRO AMERICAN GOVERNMENT	6/16 7/25	Mark Turetzky
80254	CSIS 12L	ASSEMBLY LANG LAB	7/7 8/28	Dennie Van Tassel	80193	POLS 1	INTRO AMERICAN GOVERNMENT	6/16 7/25	Mark Turetzky
80186	CSIS 12L	ASSEMBLY LANG LAB	6/16 8/8	Dennie Van Tassel	80225	PSYC 2	EARLY CHILD DEVELOP	6/16 7/25	Marlene Bumgarner
80085	CSIS 45	C++ PROGRAMMING I	6/16 8/8	Dennie Van Tassel	80228	PSYC 3	CHILD GROWTH/DEV	6/16 7/25	Marlene Bumgarner
80089	CSIS 45	C++ PROGRAMMING I	7/7 8/28	Dennie Van Tassel	80029	PSYC 5	SELF ASSESSMENT	6/16 7/25	Johanna Stewart
80200	CSIS 84	JAVASCRIPT PROGRAM	7/7 8/15	Dennie Van Tassel	80010	PSYC 5	SELF ASSESSMENT	6/16 7/25	Rosa Sharboneau
80192	CSIS 84	JAVASCRIPT PROGRAM	6/16 7/25	Dennie Van Tassel	80289	SPAN 12A	SPAN/SPAN SPEAKERS	6/16 8/11	David Perez

* Early start class. Check start date.

** Noncredit Class



Hybrid

Hybrid courses are a combination of traditional meetings and online meetings. Typically you will meet in a regular classroom once a week, and meet online once a week. You'll get the convenience of online courses, but have the advantage of meeting with your instructor and classmates too. See individual webpages for these classes for details.

80240	AH 15	SURVEY ANAT/PHYSIOL	ONLINE	Morales R
Choose a lab:				
80241	Lab	PB9	Morales R TWR	0230P-0535P
80242	Lab	PB9	Morales R TWR	0600P-0905P
80237	BIO 15	SURVEY ANAT/PHYSIOL	ONLINE	Morales R
Choose a lab:				
80238	Lab	PB9	Morales R TWR	0230P-0535P
80239	Lab	PB9	Morales R TWR	0600P-0905P

San Jose State University Telecourse at Gavilan College - Summer 2008

San Jose State University classes begin June 3, 2008. To register for television classes or for more information on dates, times and admission fees contact: Gavilan College at 408-848-4719 or SJSU at 408-924-2636.

There is a \$25 site fee per class to be paid to Gavilan College. SJSU also charges admission fees per class. Classes meet in PB11N.

COURSE	CLASS NAME	DAY	TIME	DATES
EDCO 244G	Cultural Perspectives in Counseling	Tuesday, Wednesday, Thursday	7:00-9:45 pm	June 3 - July 10
EDCO 289	Seminar in Professional Counseling	Tuesday, Wednesday, Thursday	4:00-6:45 pm	June 3 - July 10



Hollister Courses

(San Benito County)

Briggs Building
365 Fourth St.
Hollister, CA 95023
(831) 636-3783

Morgan Hill Courses

Gavilan College at the Morgan Hill Community and Cultural Center
17060 Monterey Rd.
Morgan Hill, CA 95037
(408) 782-2873



Gavilan College offers courses that meet in Morgan Hill and Hollister, on the weekend and start late in the term. Students may register for classes online or at any of the sites: Gilroy, Hollister or Morgan Hill.

Morgan Hill and Hollister Summer Hours:

May 5 – 22 Mon-Thurs: 8 am - 8 pm, Fri: 8 am - 5 pm
May 27 – June 13 Mon-Thurs: 8 am - 5:30 pm, Fridays 8 am - 12 noon
June 16 – July 25 Mon-Thurs. 8 am - 8 pm; Fri. 8 am - 12 noon

Notes: Sites are open on Fridays beginning May 30 from 8 am to 12 noon.
May 23 - Closed for Graduation
May 26 - Closed for Memorial Day
July 4 - Friday - Closed for Independence Day Holiday
July 11 - Friday - Hollister site will be closed for motorcycle rally

HOLLISTER COURSES:

CRN	COURSE#	TITLE	ROOM	TIMES	DAY	DATES	INSTRUCTOR
80218	AMT 123	INDEPENDENT STUDY	AV 102 *				
80221	AMT 123	INDEPENDENT STUDY	AV 102 *				
80012	BOT 180	MEDICAL TERM/OFFICE	HOL2	0945A-1240P	WF	6/16-7/25	Hardcastle
80090	CMUN 1A	INTRO PUBLIC SPEAK	HOL5	600P-910P	TWR	6/16-7/25	Lim T
80137	CSIS 122	COMP KEYBOARDING	HOL3	0600P-0950P	T	6/17-7/25	Ross Y
80142	CSIS 124	WINDOWS FUND	HOL3	600P-950P	R	6/19-7/17	Ross
80148	CSIS 728	WINDOWS FOR THE OA	HOL3	430P-530P	MW	6/16-7/25	Mendez
80013	ENGL 1A	COMPOSITION	HOL1	830P-835P	MWR	6/16-8/7	Mora
80071	ENGL 756**	GED PREPARATION	HOL3	100P-400P	S	6/16-7/25	Miguel
80264	ESL 704A**	ESL FOR THE WORKPL	HOL1	215P-515P	W	6/16-7/25	Segovia
80251	ESL 777**	ESL LIFESKILLS 1	HOL6	600P-730P	MWF	6/16-7/25	TBA
80106	LIB 730**	INTERNET LITERACY	HOL3	300P-430P	MW	6/16-7/25	Mendez
80065	LIB 733**	EXPLORING THE WEB	HOL3	130P-300P	MW	6/16-7/25	Mendez
80168	MATH 205	ELEM ALGEBRA	HOL4	1100A-145P	MTWRF	6/16-7/25	Wagman
80175	MATH 233	INTERMED ALGEBRA	HOL4	0810A-1050A	MTWRF	6/16-7/25	Wagman
80202	SOC 3	RACE AND ETHNICITY	HOL5	0800A-1005A	MTWR	6/16-7/25	Cervantes

* Meets at Gavilan College Aviation Department, 490 Skylane Drive, Hollister Airport, Hollister.
** Noncredit class.

MORGAN HILL COURSES:

CRN	COURSE#	TITLE	ROOM	TIMES	DAY	DATES	INSTRUCTOR
80231	CD 11C	SUPERVISION OF ADLT	MHG4	0800A-345P	S	6/16-7/25	Malaspina
80271	CD 19	INTRO CAREERS/CHLDN	MHG4	630P-950P	MWF	6/2-6/14	Bumgarner
			MHG4	0800A-400P	S	6/2-6/14	Bumgarner
80018	CSIS 6	WEBPAGE AUTHORIZING I	MHG8	410P-700P	MWR	6/16-7/10	Van Tassel
80032	CSIS 7	WEB PAGE AUTHOR II	MHG8	410P-700P	MWR	6/16-7/10	Van Tassel
80084	CSIS 10	BASIC PROGRAMMING	MHG8	705P-950P	MWR	6/16-7/10	Van Tassel
80022	DM 6	WEBPAGE AUTHORIZING I	MHG8	410P-700P	MWR	6/16-7/10	Van Tassel
80035	DM 7	WEB PAGE AUTHOR II	MHG8	410P-700P	MWR	6/16-7/10	Van Tassel
80009	ENGL 1A	COMPOSITION	MHG3	1030A-1235P	MTWR	6/16-7/25	McMillen
80174	ESL 704A**	ESL FOR THE WORKPL	MHG5	600P-800P	M	6/16-7/25	Sosa
80252	ESL 777**	ESL LIFESKILLS 1	MHG11	600P-730P	MWF	6/16-7/25	
80026	LIB 6	WEBPAGE AUTHORIZING I	MHG8	410P-700P	MR	6/16-7/10	Van Tassel
80069	LIB 733	EXPLORING THE WEB	MHG5	0930A-1130A	R	6/16-7/25	Curtis
80163	MATH 5	INTRO STATISTICS	MHG3	600P-850P	MTWR	6/16-7/25	Viarengo
80177	MATH 233	INTERMED ALGEBRA	MHG13	0830A-1145A	MTWR	6/16-7/25	Butterworth
80197	PSYC 1A	INTRO TO PSYCHOLOGY	MHG4	1030A-1235P	MTWR	6/16-7/25	Campilli
80157	RE 160	REAL ESTATE PRINC	MHG12	0830A-1230P	S	6/7-8/23	Frimann

** Noncredit class.

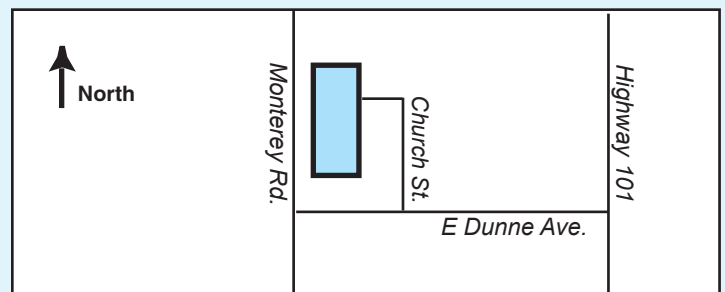
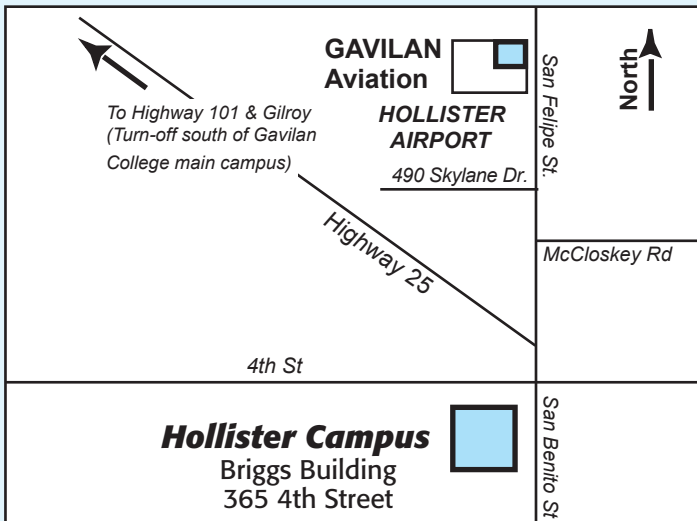

CRN Type Room Instructor Hrs. Units Days Begin-End

Summer Classes

ACCOUNTING

ACCT 103 General Office Accounting

Transferable: CSU

This course is designed to prepare students for entry-level office accounting positions. Emphasis is on practical accounting applications. This course has the option of a letter grade or pass/no pass. ADVISORY: Eligible for Mathematics 205.

80005 L/L PB16 College A 9.00 2.0 MWR 0600P-0840P

ADMINISTRATION OF JUSTICE

AJ 10 Introduction to the Administration of Justice

Transferable: CSU, UC; CAN:AJ2

The history and philosophy of justice as it evolved throughout the world; in-depth study of the American system and various sub-systems; roles and role expectations of criminal justice agents in their interrelationships in society; concepts of crime causations, punishments and rehabilitation; ethics, education and training for professionalism in the social system. ADVISORY: Eligible for English 250 and English 260.

80205 Lec BU120 Pulido D 9.00 3.0 TWR 0630P-0920P

ALLIED HEALTH

AH 11 Nutrition

Transferable: CSU, UC; CSU-GE:E2; GAV-GE: E2, F; CAN:FCS2

This course is designed to meet the needs of the Allied Health student and the general education student alike. The major aim of this course is to help the student acquire relevant information about nutrition which they can use professionally and/or personally. The course will cover the practical aspects of normal nutrition, ways to promote sound eating habits throughout the life cycle, and physiological contribution nutrients make to body structure and function. This course is also listed as BIO 11. PREREQUISITE: Eligible for English 250 and English 260. ADVISORY: Chemistry 30A and Mathematics 205.

80210 Online N/A Akrop M 3.0
 This online class will be delivered entirely over the Internet. After enrolling, start the class by going to <http://www.gavilan.edu/disted>, and log into the system. Students who have not logged in by 5 pm on the 3rd day may be dropped from the class.

AH 15 Survey of Human Anatomy and Physiology

Transferable: CSU, UC; CSU-GE:B3, B2; IGETC:5B; GAV-GE: B2, B3, E2

An introductory study of the structure and function of the human body. Includes study at the cellular and organ system levels, emphasizing integration of systems. Note that a cadaver will be observed in this course. This course is also listed as BIO 15. ADVISORY: Eligible for English 250, English 260, Biological Science 10 and Mathematics 205. Course will include viewing of a cadaver.

80240 L/L ONLINE Morales R 5.0
 This hybrid class will meet face-to-face TuWTh 3 hours a day on campus for Lab (choose one below) and online for Lecture throughout the week. An orientation will be held the first lab meeting and anyone who does not attend this first lab session will be dropped from the class. It is highly recommended that students are computer/Internet competent and keyboard skills and an email account will be necessary to converse online and be successful in the class. If you enroll in this class you must enroll in CRN 80241 or 80242.

80241 Lab PB9 Morales R 9.90 TWR 0230P-0535P
If you enroll in this class you must enroll in CRN 80240.80242 Lab PB9 Morales R 9.90 TWR 0600P-0905P
If you enroll in this class you must enroll in CRN 80240.

CRN Type Room Instructor Hrs. Units Days Begin-End

AH 32 Basic Cardiac Life Support

Transferable: CSU

Course designed to teach students skills in adult, child and infant cardiopulmonary resuscitation. Specifically designed for health professionals. Successful completion will result in certification by the American Heart Association or American Red Cross. This is a pass/no pass course. May be repeated up to three times for credit. Additional \$3.00 due upon completion for certification card.

80212 Lec HOB114 Logan C 18.00 1.0 TW 0800A-0500P
08/26/08 - 08/27/08 \$12 course material fee.80214 Lec HOB114 Logan C 18.00 1.0 WR 0800A-0500P
06/04/08 - 06/05/08 \$12 course material fee.

ANTHROPOLOGY

ANTH 1 Introduction to Physical Anthropology

Transferable: CSU, UC; CSU-GE:B2; IGETC:5B; GAV-GE:B2; CAN:ANTH2

Survey study of human biological, social and cultural development over the last several million years. The implications of evolutionary theory for the world today are also considered. Principal topics are evolutionary theory, Mendelian and molecular genetics, the fossil record, primatology, the nature of human diversity "race", and the question of continuing evolution. ADVISORY: English 250, English 260 and Mathematics 205.

80179 Online N/A Etlar D 3.0
 This online class will be delivered entirely over the Internet. After enrolling, start the class by going to <http://www.gavilan.edu/disted>, and log into the system. Students who have not logged in by 5 pm on the 3rd day may be dropped from the class.

80182 Lec AR103 Etlar D 9.20 3.0 MTWR 1030A-1235P

80184 Online N/A Klein D 3.0
 This online class will be delivered entirely over the Internet. After enrolling, start the class by going to <http://www.gavilan.edu/disted>, and log into the system. Students who have not logged in by 5 pm on the 3rd day may be dropped from the class.

ANTH 3 Introduction to Cultural Anthropology

Transferable: CSU, UC; CSU-GE:D1; IGETC:4A; GAV-GE:F; CAN:ANTH4

The comparative study of human societies and cultures. Emphasis is placed on the analysis of small scale non-western societies. Specific topics include the nature of culture, the enculturation process, kinship systems and the cross-cultural analysis of religious, political and economic institutions. Culture change and the relevance of anthropology for understanding the modern world are also considered. ADVISORY: Eligible for English 250 and English 260.

80185 Lec BU118 TBA 9.20 3.0 TR 1100A-0320P

ART

ART 6 Art Appreciation

Transferable: CSU, UC; CSU-GE:C1; IGETC:3A; GAV-GE:C1

An illustrated lecture course that surveys and introduces the visual arts from historical to contemporary times, and teaches students the basic concepts of seeing and appreciating art. ADVISORY: English 250 and English 260.

80059 Online N/A Edberg J 3.0
 This online class will be delivered entirely over the Internet. After enrolling, start the class by going to <http://www.gavilan.edu/disted>, and log into the system. Students who have not logged in by 5 pm on the 3rd day may be dropped from the class.

80061 Online N/A Edberg J 3.0
 This online class will be delivered entirely over the Internet. After enrolling, start the class by going to <http://www.gavilan.edu/disted>, and log into the system. Students who have not logged in by 5 pm on the 3rd day may be dropped from the class.

Visit the Gavilan Bookstore

on the Gilroy main campus early. Used books may be available at reduced cost.

SUMMER HOURS

Mon-Thurs: 8 am - 3 pm
 Friday: 8 am - 1 pm

EXTENDED SUMMER HOURS

During the first week of summer session the bookstore will remain open Monday-Thursday until 7 pm, Friday until 5:30 pm and Saturday from 9 am - 2 pm.

Classroom Locations: Refer to "How to Use This Schedule" on page 6.

CRN	Type	Room	Instructor	Hrs.	Units	Days	Begin-End
-----	------	------	------------	------	-------	------	-----------

ART 10A Cultural History of Ceramics

Transferable: CSU, UC; CSU-GE:C1; GAV-GE:F; CAN:ART6

An introduction to the historical developments and cultural influences of ceramic art. Development of a personal expression is realized through the combination of historical elements, observation and actual creations in clay.

80067	L/L	AR101	Rekedal J	15.20	3.0	MTWR	0830A-1200P
-------	-----	-------	-----------	-------	-----	------	-------------

ART 10B Ceramics

Transferable: CSU, UC; GAV-GE:C1

Emphasis on development of wheel throwing and advanced ceramic techniques. Glaze testing, clay body development, kiln stacking and firing are introduced. May be repeated three times for credit. This course has the option of a letter grade or pass/no pass. ADVISORY: Art 10A

80068	L/L	AR101	Rekedal J	17.20	3.0	MTWR	0830A-1235P
-------	-----	-------	-----------	-------	-----	------	-------------

ART 23 Independent Study

Transferable: CSU

Designed to afford selected students specialized opportunities for exploring areas at the independent study level. The courses may involve extensive library work, research in the community, or special projects. May be repeated until six units of credit are accrued. This course has the option of a letter grade or pass/no pass. REQUIRED: The study outline prepared by the student and the instructor must be filed with the department and the dean.

80070	Ind	AR101	Rekedal J	1.0			
-------	-----	-------	-----------	-----	--	--	--

80073	Ind	AR101	Rekedal J	2.0			
-------	-----	-------	-----------	-----	--	--	--

ART 25A Art Methods

Transferable: CSU; CSU-GE:C1; GAV-GE:C1

Art methods and learning theory for those planning to work with preschool, elementary and secondary school students. Includes art therapy as well as gifted and special learner projects. Two dimensional work in printing, drawing, collage. Also listed as CD 25A.

80075	L/L	AR102	Moginnis R	18.00	3.0	MTWR	0830A-1215P
-------	-----	-------	------------	-------	-----	------	-------------

ART 25B Art Methods

Transferable: CSU; GAV-GE:C1

Art methods, creativity and learning theory for those planning to work with preschool, elementary, and secondary school students. Includes art therapy as well as gifted and special learner projects. Three dimensional work in sculpture, bas relief, mobiles, paper mache', plaster, and various 3-D materials. Also listed as CD 25B.

80077	L/L	AR102	Moginnis R	15.60	3.0	MTWR	0830A-1215P
-------	-----	-------	------------	-------	-----	------	-------------

ART 85 Web Design I: Dreamweaver

Transferable: CSU; GAV-GE:C1

Basic and intermediate principles of designing Web pages/sites using the Dreamweaver web design software and HTML. Emphasis will be on good design and the use of tables, frames, forms, rollovers, DHTML, XHTML, behaviors, and CSS. Also includes site maintenance and the integration of multimedia components such as graphics, sound, animation, and video. This course is for the content person to design, develop, and maintain effective Web sites. This course is also listed as CSIS 85 and DM 85. This course has the option of a letter grade or pass/no pass. May be repeated twice for credit. ADVISORY: CSIS 6 or basic knowledge of HTML.

80108	Lec	BU111	Howell P	6.60	2.0	TR	0900A-1205P
-------	-----	-------	----------	------	-----	----	-------------

Beginning with the summer and fall 2008 enrollment period social security numbers will no longer be used as student identifiers. Find your new Gavilan Student ID and choose a log-on password by going to www.gavilan.edu and clicking on the Self-Service Banner icon. You will use your new ID and password to log into Self-Service Banner and register for summer and fall classes.

CRN	Type	Room	Instructor	Hrs.	Units	Days	Begin-End
-----	------	------	------------	------	-------	------	-----------

ART 108 Digital Media Lab

Transferable: CSU; GAV-GE:C1

Supervised practice and individualized computer assisted learning of software applications and techniques commonly found in the design and production of digital media (e.g., digital art and imaging, digital photography, digital print, digital audio/video, web design/authoring, DVD/CD ROMs, animation). Supplements lecture courses. Open entry/exit, so may be added at anytime during the semester. This is a pass/no pass course. May be repeated three times for credit. Also listed as DM 108 and CSIS 108. ADVISORY: CSIS 1 or CSIS 2/2L or equivalent computer experience.

80119	Lab	L1128	Beede R	7.60	.5	MTWR	1000A-1145A
07/07/08 - 07/31/08							

80285	Lab	L1128	Beede R	7.60	.5	MTWR	1200P-0145P
07/07/08 - 07/31/08							

AVIATION MAINTENANCE TECHNOLOGY

AMT 123 Independent Study

Transferable: CSU

Designed to afford selected students specialized opportunities for exploring areas at the independent study level. The courses may involve extensive library work, research in the community, or special projects. May be repeated until six units of credit are accrued. This course has the option of a letter grade or pass/no pass. REQUIRED: The study outline prepared by the student and the instructor must be filed with the department and the dean. Meets at Gavilan College Aviation Department, 490 Skylane Drive, Hollister Airport, Hollister.

80218	Ind	AV102	Flippen T	1.0			
Above class meets at the Hollister Airport.							

80221	Ind	AV102	Flippen T	2.0			
Above class meets at the Hollister Airport.							

BIOLOGICAL SCIENCE

BIO 10 Principles of Biology

Transferable: CSU, UC; CSU-GE: B2, B3; IGETC:5B; GAV-GE:B2, B3

An introductory biology course covering functions at the cellular and organismal levels. Includes study of the basic principles of metabolism, heredity, evolution and ecology. Primarily for non-biological science majors. ADVISORY: Eligible for English 250, English 260 and Mathematics 205.

80151	Lec	PB5	Morikang E	9.00	4.0	MWF	1000A-1250P
If you enroll in this CRN you must also enroll in CRN 80153 or 80245							

80153	Lab	PB8	Morikang E	6.00	MWF		0800A-0950A
If you enroll in this CRN you must also enroll in CRN 80151.							

80245	Lab	PB8	Morikang E	6.00	MWF		0110P-0300P
If you enroll in this CRN you must also enroll in CRN 80151							

BIO 11 Nutrition

Transferable: CSU, UC; CSU-GE:E2; GAV-GE:E2, F; CAN:FCS2

This course is designed to meet the needs of the Allied Health student and the general education student alike. The major aim of this course is to help the student acquire relevant information about nutrition which they can use professionally and/or personally. The course will cover the practical aspects of normal nutrition, ways to promote sound eating habits throughout the life cycle, and physiological contribution nutrients make to body structure and function. This course is also listed as Allied Health 11. PREREQUISITE: Eligible for English 250 and English 260 ADVISORY: Chemistry 30A and Mathematics 205

80211	Online	N/A	Akrop M	3.0			
-------	--------	-----	---------	-----	--	--	--

 **This online class will be delivered entirely over the Internet. After enrolling, start the class by going to <http://www.gavilan.edu/disted>, and log into the system. Students who have not logged in by 5 pm on the 3rd day may be dropped from the class.**

Your educational plan:

You are expected to take the responsibility for scheduling an appointment with a counselor, preferably at least once a semester. The purpose of this appointment is to develop, review and update your educational plan to ensure that you are taking the appropriate courses to meet your educational goal.

CRN Type Room Instructor Hrs. Units Days Begin-End

BIO 15 Survey of Human Anatomy and Physiology

Transferable: CSU, UC; CSU-GE:B3, B2; IGETC:5B; GAV-GE:B3, B2

An introductory study of the structure and function of the human body. Includes study at the cellular and organ system levels, emphasizing integration of systems. Note that a cadaver will be observed in this course. This course is also listed as Allied Health 15. ADVISORY: Biological Science 10, Eligible for English 250, English 260 and Mathematics 205. Course will include the viewing of a cadaver.

80237 L/L Online Morales R 5.0
 This hybrid class will meet face-to-face TuWTh 3 hours a day on campus for Lab (choose one below) and online for Lecture throughout the week. An orientation will be held the first lab meeting and anyone who does not attend this first lab session will be dropped from the class. It is highly recommended that students are computer/Internet competent and keyboard skills and an email account will be necessary to converse online and be successful in the class. If you enroll in this class you must enroll in CRN 80238 or 80239.

80238 Lab PB9 Morales R 9.90 TWR 0230P-0535P
 If you enroll in this class you must enroll in CRN 80237.

80239 Lab PB9 Morales R 9.90 TWR 0600P-0905P
 If you enroll in this class you must enroll in CRN 80237.

BUSINESS OFFICE TECHNOLOGY

BOT 112 Business Computations with Machines

Transferable: CSU

Self-paced course in the operation of the electronic printing calculator. This course provides theory and practice in business applications with emphasis on mathematical problem solving. This course has the option of a letter grade or credit/no credit. ADVISORY: Eligible for Mathematics 402.

80294 Lab BU110 Gaffney 3.00 0.5 MTWR 1000A-0100P
 07/14/08-07/24/08

BOT 180 Medical Terminology for the Office

Transferable: CSU

This course introduces fundamentals of medical word building used in the health profession (prefixes, word roots, suffixes and abbreviations) as well as review of body systems, with emphasis on analysis, definition, spelling and pronunciation. This course had the option of a letter grade or pass/no pass. ADVISORY: Eligible for English 250 and English 260.

80012 Lec HOL2 Hardcastle C 6.00 3.0 WF 0945A-1240P
 Above class meets at the Hollister Briggs site.

CHEMISTRY

CHEM 30A Elementary Chemistry

Transferable: CSU, UC; CSU-GE:B3, B1; IGETC:5A; GAV-GE:B3, B1; CAN:CHEM6, CHEM SEQ B

This is a first semester college chemistry course designed for majors preparing to take Chemistry 1A, nursing and allied health students, as well as general education. The course will cover the principles of chemistry including properties of matter, energy, atomic theory, the Periodic Table, stoichiometry, elements and compounds, the properties of bonding, molecular structure, chemical reactions, states of matter, acidity, solutions and gases, as well as an introductory to organic chemistry. ADVISORY: Mathematics 205; eligible for English 250 and English 260.

80246 Lab PB7 Clark D 11.20 MTWR 1100A-0130P
 Lec PB4 Clark D 8.00 4.0 MTWR 0900A-1100A

CHILD DEVELOPMENT

CD 2 Early Child Development

Transferable: CSU, UC; CSU-GE:E; IGETC:4I; GAV-GE:D2

A systematic study of the child from prenatal life through the preschool years. The course integrates the basic concepts of physical, cognitive and psychosocial development at each major stage of life during this period. This course is also listed as PSYC 2. This course has the option of a letter grade or pass/no pass. ADVISORY: Eligible for English 250 and English 260; transfer students consult with advisor.

80223 Online N/A Bumgarner M 3.0
 This online class will be delivered entirely over the Internet. After enrolling, start the class by going to <http://www.gavilan.edu/disted>, and log into the system. Students who have not logged in by 5 pm on the 3rd day may be dropped from the class.

CRN Type Room Instructor Hrs. Units Days Begin-End

CD 3 Child Growth and Development During the School Years

Transferable: CSU, UC; CSU-GE:E; IGETC:4I; GAV-GE:D2

Continuation of the study of the principles of child development with emphasis on children from six years through adolescence. Includes developmental theories and topics relevant to these ages. This course is also listed as PSYC 3. This course has the option of a letter grade or pass/no pass. ADVISORY: Eligible for English 250 and English 260; Child Development 2; transfer students consult with advisor.

80226 Online N/A Bumgarner M 3.0
 This online class will be delivered entirely over the Internet. After enrolling, start the class by going to <http://www.gavilan.edu/disted>, and log into the system. Students who have not logged in by 5 pm on the 3rd day may be dropped from the class.

CD 11C Supervision of Adults: The Mentor Teacher

Transferable: CSU

A study of the methods and principles of supervising adults in early childhood settings. Emphasis is on the role of the experienced classroom teacher who functions as a "mentor/supervisor" to teachers, aides, and other adults. This course meets the requirements for the State Child Development Permit Matrix: "2 unit adult supervision class" and the Mentor Teacher Program. Lectures, discussions, in class and out of class activities, role-play simulations, readings, individual and group assignments as well as videos and guest presenters will be used. ADVISORY: Prefer that students meet the requirements for the State Child Development Teacher Permit or completion of a college-level course of study in child development or early childhood education, or equivalent, or permission of instructor.

80231 Lec MHG4 Malaspina B 7.30 2.0 S 0800A-0345P
 Above class meets at Morgan Hill Community site. This class meets 5 Saturdays, June 14, 21, 28, July 12 & 13. There will NOT be class on Saturday, July 5.

CD 16 Exploring Mathematics with Children

Transferable: CSU

Introduces the excitement and extensiveness of math experiences for children and presents an organized, sequential approach for developing a math curriculum. Students develop a folder of math activities for children aged 2-8. ADVISORY: Eligible for English 250 and English 260.

80233 Online N/A Clabaugh D 1.0
 This online class will be delivered entirely over the Internet. After enrolling, start the class by going to <http://www.gavilan.edu/disted>, and log into the system. Students who have not logged in by 5 pm on the 3rd day may be dropped from the class.

CD 17 Exploring Science with Children

Transferable: CSU

Learn to teach a coordinated science curriculum covering life, natural and physical science concepts familiar and interesting to children age 2-8. Using easily found or low-cost materials and the Socratic method of questioning are primary strategies for developing reasoning skills and science concepts in children. ADVISORY: Eligible for English 250 or 260.

80256 Online N/A Clabaugh D 1.0
 This online class will be delivered entirely over the Internet. After enrolling, start the class by going to <http://www.gavilan.edu/disted>, and log into the system. Students who have not logged in by 5 pm on the 3rd day may be dropped from the class.

CD 19 Introduction to Careers with Children

Transferable: CSU

An overview of Department of Social Services and Department of Education regulations regarding child care workers in California. Self-assessment techniques with emphasis on teacher-child and teacher-adult relationships and personal evaluations. Basic principles of curriculum development and discipline techniques. This course has the option of a letter grade or pass/no pass. ADVISORY: Eligible for English 250 and English 260.

80271 Lec MHG4 Bumgarner M 10.80 2.0 MWF 0630P-0950P
 Lec MHG4 Bumgarner M 8.00 S 0800A-0400P
 06/20/08 - 06/14/08 Above class meets at Morgan Hill Community site.

CD 20 Children's Language and Literature

Transferable: CSU

A developmental view of children's language and literacy learning in a framework of children's literature. Students will be presented with steps in children's literacy learning in order to help them organize classrooms and plan activities to support the growth of writing and reading. Students will study historical trends in children's literature and participate in practical experiences and activities that use a wide range of techniques and materials for advancing language comprehension and usage. This course has the option of a letter grade or pass/no pass. ADVISORY: Eligible for English 250 and English 260.

80257 Lec PB16 Muscardi D 9.00 3.0 MWF 0900A-1200P

CRN	Type	Room	Instructor	Hrs.	Units	Days	Begin-End
CD 21 Creative Experiences for Children							
Transferable: CSU							
An interpretation of the values of creative experiences for young children. Illustrated lectures and demonstrations with student participation cover such topics as use of blocks, music, rhythms, body movement, art experiences and other creative projects. ADVISORY: Eligible for English 250 and English 260.							
80258	L/L	PB16	Clabaugh D	6.00	2.0	TR	0600P-0900P
	L/L	PB16	Clabaugh D	6.00		S	0900A-0300P

CD 25A Art Methods							
Transferable: CSU; CSU-GE:C1; GAV-GE:C1							
Art methods and learning theory for those planning to work with preschool, elementary and secondary students. Includes art therapy as well as gifted and special learner projects. Two dimensional work in printing, painting, drawing, collage. Also listed as ART 25A.							
80078	L/L	AR102	McGinnis R	15.60	3.0	MTWR	0830A-1215P

CD 25B Art Methods							
Transferable: CSU; GAV-GE:C1							
Art methods, creativity and learning theory for those planning to work with preschool, elementary, and secondary school students. Includes art therapy as well as gifted and special learner projects. Three dimensional work in sculpture, bas relief, mobiles, paper mache', plaster, and various 3-D materials. Also listed as ART 25B.							
80079	L/L	AR102	McGinnis R	15.60	3.0	MTWR	0830A-1215P

CD 160 Child Care First Aid and CPR							
Transferable: CSU							
First aid training to prepare child care professionals to meet the need of emergencies when medical assistance is delayed. Includes information on the prevention of childhood injuries and the prevention of communicable diseases including HIV/AIDS and the use of Universal Precautions. (Satisfies the California Community Care Licensing requirement for 15 hours of specialized health and safety training.) This is a pass/no pass course. May be repeated three times for credit. \$12.00 course material fee.							
80270	Lec	CDC127	Alonzo S	3.00	1.0	F	0600P-0850P
	Lec	CDC127	Alonzo S	7.60		S	0900A-0420P
07/11/08 - 07/19/08 This class meets one Friday, July 11 and two Saturdays, July 12 and 19.							

COMMUNICATION STUDIES

CMUN 1A Introduction to Public Speaking							
Transferable: CSU, UC; CSU-GE:A1; IGETC:1C; GAV-GE:A1; CAN:SPCH4							
Basic principles of effective human communication and their function in contemporary public settings; emphasis is on the speech to inform, with special consideration given to fundamental communication skills, including organization, reasoning, explanation and listening. ADVISORY: Eligible for English 250 and English 260.							
80088	Lec	PB1	Cowan D	9.20	3.0	MTWR	1245P-0250P
80090	Lec	HOL5	Liim T	10.20	3.0	TWR	0600P-0910P
Above class meets at the Hollister Briggs site.							

CMUN 10 Small Group Communication							
Transferable: CSU, UC; CSU-GE:A1; IGETC:1C; GAV-GE:A1; CAN:SPCH10							
An introductory course that develops basic individual reasoning skills, insights and experiences in information-sharing, interacting, decision-making, problem-solving, resolution of disputes and other issues central to group processes. ADVISORY: Eligible for English 250 and English 260.							
80091	Lec	PB1	Waddell E	9.20	3.0	MTWR	0800A-1005A
Recommended for students participating in TRIO Summer Bridge Program. Students are encouraged to also take GUID 200, CRN 80261. See ad on page 21.							
80096	Lec	PB1	Cowan D	9.20	3.0	MTWR	1030A-1235P

Summer Final Exams

are the last day of each class.

CRN	Type	Room	Instructor	Hrs.	Units	Days	Begin-End
CMUN 129 Presentation Graphics - MS Powerpoint							
Transferable: CSU							
This introductory course in presentation graphics will use Microsoft Office's "PowerPoint" software to create a computerized presentation with text and objects. This course has the option of a letter grade or pass/no pass. May be repeated three times for credit. This course is also listed as CSIS 129. ADVISORY: CSIS 126 or word processing skills in the Windows environment.							
80207	Lec	BU110	Gaffney S	16.00	1.0	MTWR	0900A-0100P
07/16/08 - 07/23/08							

COMPUTER SCIENCE & INFORMATION SYSTEMS

CSIS 1 Computer Literacy - MS Office							
Transferable: CSU, UC; GAV-GE:E2; CAN:CSC12							
An introduction to terminology, design, operation for the novice user. Student will gain experience using the Internet for searches and email. They will complete projects using various software including word processing, spreadsheets, database, presentation graphics, and integration. This course has the option of a letter grade or pass/no pass. ADVISORY: Eligible for English 250 and English 260; completion of CSIS 122.							
80015	Lec	BU110	Littig A	8.00	2.0	MW	0600P-0950P

CSIS 3 Research Skills							
Transferable: CSU							
Research and evaluation skills using the Internet and other electronic resources, as well as traditional printed materials. Also listed as LIB 3. This course has the option of a letter grade or pass/no pass. May be repeated once for credit. ADVISORY: Eligible for English 250 and 260.							
80134	Online	N/A	Young D		2.0		
06/16/08 - 08/08/08 This online class will be delivered entirely over the Internet. After enrolling, start the class by going to http://www.gavilan.edu/disted , and log into the system. Students who have not logged in by 5 pm on the 3rd day may be dropped from the class.							

CSIS 6 Web Page Authoring I							
Transferable: CSU; GAV-GE:E2							
An introduction to using Hypertext Mark-Up Language (HTML) and Extensible HTML (XHTML) to create web pages which can be uploaded and displayed on the World Wide Web. Students will use HTML/XHTML to create web pages with text in various sizes and colors, links to other sites, background color or patterns, graphics, tables and mailto links. Principles of design and color as they apply to screen presentations will be included. This course has the option of a letter grade or pass/no pass. May be repeated three times for credit. Also listed as LIB 6 and DM 6. ADVISORY: CSIS 1 or CSIS 2 or CSIS 3/LIB 3 advised.							
80018	Lec	MHG8	Van Tassel D	9.00	2.0	MWR	0410P-0700P
06/16/08 - 07/10/08 Above class meets at Morgan Hill Community site.							

CSIS 7 Web Page Authoring II							
Transferable: CSU							
This course is a continuation of CSIS 6, Web Page Authoring I. Topics that will be covered include XHTML, frames, advanced tables, forms, scripting languages, image maps, Cascading Style Sheets (CSS), and new trends in web page technology. This course has the option of a letter grade or pass/no pass. May be repeated three times for credit. This course is also listed as DM 7. ADVISORY: CSIS 6							
80032	Lec	MHG8	Van Tassel D	9.00	2.0	MWR	0410P-0700P
06/16/08 - 07/10/08 Above class meets at Morgan Hill Community site.							

CSIS 8 Introduction to the Internet							
Transferable: CSU; GAV-GE:E2							
This course will provide students the opportunity to learn to use the Internet and the World Wide Web. Topics to be covered include history of the Internet and development of the WWW, web browsers, search engines, tools to develop web pages, how to get connected and local Internet providers. This is a pass/no pass course. May be repeated three times for credit. ADVISORY: CSIS 124.							
80038	Online	N/A	Venable E		1.0		
This online class will be delivered entirely over the Internet. After enrolling, start the class by going to http://www.gavilan.edu/disted , and log into the system. Students who have not logged in by 5 pm on the 3rd day may be dropped from the class.							

CRN Type Room Instructor Hrs. Units Days Begin-End

CSIS 10 BASIC Programming

Transferable: CSU, UC

This course is an introduction to programming using BASIC. No previous programming background is assumed. This is a good class for those new to programming and recommended for non-programmers that want to take other programming classes. This course has the option of a letter grade or pass/no pass. ADVISORY: CSIS 1 or CSIS 2 or equivalent experience.

80084 Lec MHG8 Van Tassel D 8.70 2.0 MWR 0705P-0950P
06/16/08 - 07/10/08 Above class meets at Morgan Hill Community site.

CSIS 12 Assembly Language Programming

Transferable: CSU, UC

Fundamentals of assembly language programming concepts and techniques. Topics include internal representation of data, arithmetic operations, logic statements, and general assembly language commands. Introduce low level language architecture including assemblers, linkage editors, and loaders. This course has the option of a letter grade or pass/no pass. COREQUISITE: CSIS 12L Assembly Language Programming Lab ADVISORY: CSIS 45 (C++ Programming) or programming experience. Math 233 (Intermediate Algebra)

80180 Online N/A Van Tassel D 3.0
06/16/08 - 08/08/08 This online class will be delivered entirely over the Internet. After enrolling, start the class by going to <http://www.gavilan.edu/disted>, and log into the system. Students who have not logged in by 5 pm on the 3rd day may be dropped from the class.

80253 Online N/A Van Tassel D 3.0
07/07/08 - 08/28/08 This online class will be delivered entirely over the Internet. After enrolling, start the class by going to <http://www.gavilan.edu/disted>, and log into the system. Students who have not logged in by 5 pm on the 3rd day may be dropped from the class.

CSIS 12L Assembly Language Programming Lab

Transferable: CSU, UC

Supplemental practice in coursework associated with this course is provided. Concurrent enrollment in CSIS 12 is required. This is a pass/no pass course. COREQUISITE: CSIS 12 Assembly Language Programming

80186 Online N/A Van Tassel D 1.0
06/16/08 - 08/08/08 This online class will be delivered entirely over the Internet. After enrolling, start the class by going to <http://www.gavilan.edu/disted>, and log into the system. Students who have not logged in by 5 pm on the 3rd day may be dropped from the class.

80254 Online N/A Van Tassel D 1.0
07/07/08 - 08/28/08 This online class will be delivered entirely over the Internet. After enrolling, start the class by going to <http://www.gavilan.edu/disted>, and log into the system. Students who have not logged in by 5 pm on the 3rd day may be dropped from the class.

CSIS 45 C++ Programming I

Transferable: CSU, UC; GAV-GE:E2; CAN:CSCI18

An introduction to the concepts and methods of computer programming using C++. Students will be introduced to procedural and object-oriented programming design methodology. Topics covered include variable and constant declarations, selection statements, repetition, functions and recursion, arrays, strings, pointers, and an introduction to classes and objects. This course will prepare students for the Programming II class. This course has the option of a letter grade or pass/no pass. ADVISORY: CSIS 10 or equivalent. Math 205 (Elementary Algebra)

80085 Online N/A Van Tassel D 4.0
06/16/08 - 08/08/08 This online class will be delivered entirely over the Internet. After enrolling, start the class by going to <http://www.gavilan.edu/disted>, and log into the system. Students who have not logged in by 5 pm on the 3rd day may be dropped from the class.

80089 Online N/A Van Tassel D 4.0
07/07/08 - 08/28/08 This online class will be delivered entirely over the Internet. After enrolling, start the class by going to <http://www.gavilan.edu/disted>, and log into the system. Students who have not logged in by 5 pm on the 3rd day may be dropped from the class.

CRN Type Room Instructor Hrs. Units Days Begin-End

CSIS 84 JavaScript Programming

Transferable: CSU, UC

Fundamentals of JavaScript client-side programming for Web pages requiring data collection or other user interaction. Students will create Web pages that execute on the client (personal system) using JavaScript. This course may be repeated one time for credit. This course has the option of a letter grade or pass/no pass. ADVISORY: CSIS 6

80192 Online N/A Van Tassel D 2.0
This online class will be delivered entirely over the Internet. After enrolling, start the class by going to <http://www.gavilan.edu/disted>, and log into the system. Students who have not logged in by 5 pm on the 3rd day may be dropped from the class.

80200 Online N/A Van Tassel D 2.0
07/07/08 - 08/15/08 This online class will be delivered entirely over the Internet. After enrolling, start the class by going to <http://www.gavilan.edu/disted>, and log into the system. Students who have not logged in by 5 pm on the 3rd day may be dropped from the class.

CSIS 85 Web Design I: Dreamweaver

Transferable: CSU; GAV-GE:C1

Basic and intermediate principles of designing Web pages/sites using the Dreamweaver web design software and HTML. Emphasis will be on good design and the use of tables, frames, forms, rollovers, DHTML, XHTML, behaviors, and CSS. Also includes site maintenance and the integration of multimedia components such as graphics, sound, animation, and video. This course is for the content person to design, develop, and maintain effective Web sites. This course is also listed as ART 85 and DM 85. This course has the option of a grade or pass/no pass. May be repeated twice for credit. ADVISORY: CSIS 6 or basic knowledge of HTML.

80092 Lec BU111 Howell P 6.60 2.0 TR 0900A-1205P

CSIS 108 Digital Media Lab

Transferable: CSU; GAV-GE:C1

Supervised practice and individualized computer assisted learning of software applications and techniques commonly found in the design and production of digital media (e.g., digital art and imaging, digital photography, digital print, digital audio/video, web design/authoring, DVD/CD ROMs, animation). Supplements lecture courses. Open entry/exit, so may be added at anytime during the semester. This is a pass/no pass course. May be repeated three times for credit. Also listed as ART 108 and DM 108. ADVISORY: CSIS 1 or CSIS 2/2L or equivalent computer experience.

80118 Lab LI128 Beede R 7.60 .5 MTWR 1000A-1145A
07/07/08 - 07/31/08

80286 Lab LI128 Beede R 7.60 .5 MTWR 1200P-0145P
07/07/08 - 07/31/08

CSIS 122 Computer Keyboarding

Transferable: CSU

A self-paced course for students who wish to master the alphabetic and numeric keyboard on the computer. This course is designed for students who do not know the alphabetic keyboard by "touch" and for those who want to improve their ability to type straight copy with increased speed and accuracy. The course provides "hands-on" instruction to help students reach optimum computer keyboarding skills within a limited time. This is a pass/no pass course. Course may be repeated until 3 units are accrued.

An orientation is required. for the following classes.

A schedule is available in BU 110. Gavilan Business/Computer Lab hours in BU 110: DAY students from 9 a.m. - 1:00 p.m., Monday - Thursday. Open entry - open exit.

80124 Lab BU110 Gaffney S 8.00 .5 MTWR 0910A-1100A

80127 Lab BU110 Milar E 8.00 1.0 MTWR 0910A-0100A

80132 Lab BU110 Gaffney S 8.00 .5 MTWR 1110A-0100P

80137 Lab HOL3 Ross Y 4.00 .5 T 0600P-0950P
Above class meets at the Hollister Briggs site.

CSIS 124 Windows Fundamentals

Transferable: CSU

This course provides fundamental information on the Windows environment for the computer. Introductory Windows operations and file management are covered. This is a pass/no pass course. This course may be repeated three times for credit. ADVISORY: Basic keyboarding skill.

80292 Lec BU110 Milar E 19.20 1.0 MTWR 0900A-0100P
07/30/08 - 08/06/08

80141 Lec BU110 Milar E 19.20 1.0 MTWR 0900A-0100P
06/23/08 - 06/30/08

80142 Lec HOL3 Ross Y 4.00 1.0 R 0600P-0950P
06/19/08 - 07/17/08 Above class meets at the Hollister Briggs site.

What is a **CRN**?

CRN stands for Course Reference Number. This is the number (used to be called section) that you will use to register for your classes.

CRN Type Room Instructor Hrs. Units Days Begin-End

CSIS 126 Word Processing - MS Word

Transferable: CSU

This introductory course for word processing with Windows is designed for business and non-business majors. Students will develop word processing skills to create a document, select and edit text, move and copy text, use the spelling, grammar, and thesaurus features, format text, and create headers, footnotes for a research paper. This course has the option of a letter grade or pass/no pass and may be repeated when the software changes. ADVISORY: Eligible for English 260 and basic keyboarding skills.

80293	Lec	BU110	Gaffney S	16.00	2.0	MTWR	0900A-0100P
08/07/08 - 08/21/08							
80145	Lec	BU110	Gaffney S	16.00	2.0	MTWR	0900A-0100P
07/01/08 - 07/15/08							

CSIS 128 Database - MS Access

Transferable: CSU

Introduction to Microsoft Access, a relational database management software tool. Students will learn to create and manage a database. This course will help prepare students for taking the Access MOUS (Microsoft Office User Specialist) exams. May be repeated three times for credit. This course has the option of a letter grade or pass/no pass. ADVISORY: CSIS 1 or CSIS 2 or equivalent knowledge.

80248	Lec	BU110	Venable E	6.60	2.0	TR	0600P-0905P
-------	-----	-------	-----------	------	-----	----	-------------

80249	Online	N/A	Venable E		2.0		
 This online class will be delivered entirely over the Internet. After enrolling, start the class by going to http://www.gavilan.edu/disted , and log into the system. Students who have not logged in by 5 pm on the 3rd day may be dropped from the class.							

CSIS 129 Presentation Graphics - MS PowerPoint

Transferable: CSU

This introductory course in presentation graphics will use Microsoft Office's "PowerPoint" software to create a computerized presentation (slide show) with text and objects. This course is also listed as CMUN 129. This course has the option of a letter grade or pass/no pass. May be repeated three times for credit. ADVISORY: CSIS 126 or word processing skills in the Windows environment.

80150	Lec	BU110	Gaffney S	16.00	1.0	MTWR	0900A-0100P
07/16/08 - 07/23/08							

CSIS 151 Introduction to XML Authoring

Transferable: CSU

This course provides an introduction and overview of eXtensible Markup Language (XML) and XML related technologies used to develop content and manipulate data for commercial web sites. XML is a revolutionary language which is rapidly becoming a Web development standard for business-to-business transactions, and for database manipulation and searching. The class will cover well-formed and valid XML documents, namespaces, schemas, cascading style sheets (CSS), and XSLT. This course has the option of a letter grade or pass/no pass. May be repeated three times for credit. ADVISORY: CSIS 6

80152	Online	N/A	Van Tassel D		3.0		
 06/16/08 - 08/08/08 This online class will be delivered entirely over the Internet. After enrolling, start the class by going to http://www.gavilan.edu/disted , and log into the system. Students who have not logged in by 5 pm on the 3rd day may be dropped from the class.							

CSIS 570 Computer Access Evaluation

Transferable: No

This course is intended to provide an in-depth computer access evaluation in order to determine an appropriate access environment for a student with a disability or multiple disabilities. This is a pass/no pass course. May be repeated as necessary based on measurable progress as documented in the Student Educational Contract. This is an open entry, open exit course. ADVISORY: This course is intended for students with a verified disability who show a need for the use of assistive computer programs and/or equipment or demonstrated academic deficit.

80104	Lab	LI105	Maringer J		.5		
-------	-----	-------	------------	--	----	--	--



CSIS 1
Computer Literacy MS Office

2 UNITS

An Introduction to MS Office

CSIS 10
BASIC Programming

An introductory course for those students exploring a computer programming career.

Instructor: Dennie Van Tassel

CSIS 10 is transferable to UC and CSU

CSIS 129
Presentation Graphics - MS Powerpoint

1 unit - 2 week course



CRN 80150 Instructor: Sandra Gaffney MTuWTh 9 am - 1 pm
Dates: 7/16- 7/23

Also listed as CMUN 129

UPDATE YOUR COMMUNICATION SKILLS!!

ADD **WEB PAGE CONSTRUCTION** TO YOUR COMMUNICATIONS TOOLBOX!

CSIS/DM/LIB 6 WebPage Authoring I

The basic skills of webpage construction

CSIS/DM 7 Web Page Authoring II

SEE YOU IN THE COMPUTER LABS!!



Brush Up your Software Skills

Most Computer Applications classes are repeatable.

Classroom Locations:

Refer to "How to Use This Schedule" on page 6.

CRN Type Room Instructor Hrs. Units Days Begin-End

CSIS 571 Computer Assisted Instruction

Transferable: No

This course is an Assistive Computer Technology Lab designed for students who are eligible for Disability Services. The course is designed to improve basic academic skills and/or cognitive processes through the use of appropriate software or to learn assistive devices designed to make computers accessible. Course content is based on individual educational plans which are developed for each student. This is a pass/no pass course. May be repeated as necessary based on measurable progress as documented in the Student Educational Contract. This is an open entry, open exit course. ADVISORY: This course is intended for students with a verified disability who show a need for the use of adaptive computer programs and/or equipment or demonstrated academic deficit.

80122 Lab LI105 Maringer J .5

COSMETOLOGY

COS 207 Contemporary Styling

Transferable: No

Studies and techniques in braiding, weaving, glass nails, silk wrap, individual lash and brow tinting, corrective make-up and low lights. This is a 6 week class offered in summer session only. May be repeated once for credit. ADVISORY: Satisfactory completion of Cosmetology 200. Eligible for English 250, 260, and Mathematics 205. Intermediate and Advanced cosmetology enrollments only.

80236 L/L COS109 Hernandez R 35.20 4.5 MTWR 0800A-0430P
06/09/08 - 07/17/08

80243 L/L COS109 Ramirez G 35.20 4.5 MTWR 0800A-0430P
L/L COS109 Khanna N 35.20 MTWR 0800A-0430P
L/L COS109 Andre M 35.20 MTWR 0800A-0430P
07/07/08 - 07/17/08 This class is taught by three instructors.

COS 220 Scientific Skin Care (Esthetics)

Transferable: No

An introductory course designed to provide the skills necessary to be employed as an Esthetician (Facialist). Skills taught include skin care and treatment, cosmetics, and the use of electrical modalities. REQUIRED: 17 years of age, completed 10th grade or equivalent, as per State Board of Cosmetology.

80255 L/L COS102 Juarez A 30.00 MTWRF 0400P-0950P
Gomez D

06/02/08 - 07/25/08 Students must purchase a uniform, lab coat, shoes and skin care kit; (approximately \$500). This does not include books and classroom materials.

COS 223 Independent Study

Transferable: No

Designed to afford selected students specialized opportunities for exploring areas at the independent study level. The courses may involve extensive library work, research in the community, or special projects. May be repeated until six units of credit are accrued. This course has the option of a letter grade or pass/no pass. REQUIRED: The study outline prepared by the student and the instructor must be filed with the Department and the Area Dean.

80259 Ind COS109 Hernandez R 1.0
06/09/08 - 07/17/08

80260 Ind COS109 Hernandez R 2.0
06/09/08 - 07/17/08

DIGITAL MEDIA

DM 6 Web Page Authoring I

Transferable: CSU; GAV-GE:E2

An introduction to using Hypertext Mark-Up Language (HTML) and Extensible HTML (XHTML) to create web pages which can be uploaded and displayed on the World Wide Web. Students will use HTML/XHTML to create web pages with text in various sizes and colors, links to other sites, background color or patterns, graphics, tables and mailto links. Principles of design and color as they apply to screen presentations will be included. This course has the option of a letter grade or pass/no pass. May be repeated three times for credit. Also listed as CSIS 6 and LIB 6. ADVISORY: CSIS 1 or CSIS 2 or CSIS 3/LIB 3 advised.

80022 Lec MHG8 Van Tassel D 9.00 2.0 MWR 0410P-0700P
06/16/08 - 07/10/08 Above class meets at Morgan Hill Community site.

CRN Type Room Instructor Hrs. Units Days Begin-End

DM 7 Web Page Authoring II

Transferable: CSU

This course is a continuation of CSIS 6, Web Page Authoring I. Topics that will be covered include XHTML, frames, advanced tables, forms, scripting languages, image maps, Cascading Style Sheets (CSS), and new trends in web page technology. This course has the option of a letter grade or pass/no pass. May be repeated three times for credit. This course is also listed as CSIS 7. ADVISORY: CSIS 6

80035 Lec MHG8 Van Tassel D 9.00 2.0 MWR 0410P-0700P
06/16/08 - 07/10/08 Above class meets at Morgan Hill Community site.

DM 85 Web Design I: Dreamweaver

Transferable: CSU; GAV-GE:C1

Basic and intermediate principles of designing Web pages/sites using the Dreamweaver web design software and HTML. Emphasis will be on good design and the use of tables, frames, forms, rollovers, DHTML, XHTML, behaviors, and CSS. Also includes site maintenance and the integration of multimedia components such as graphics, sound, animation, and video. This course is for the content person to design, develop, and maintain effective Web sites. This course is also listed as ART 85 and CSIS 85. This course has the option of a letter grade or pass/no pass. May be repeated twice for credit. ADVISORY: CSIS 6 or basic knowledge of HTML.

80114 Lec BU111 Howell P 6.60 2.0 TR 0900A-1205P

DM 108 Digital Media Lab

Transferable: CSU; GAV-GE:C1

Supervised practice and individualized computer assisted learning or software applications and techniques commonly found in the design and production of digital media (e.g., digital art and imaging, digital photography, digital print, digital audio/video, web design design/authoring, DVD/CD ROMs, animation). Supplements lecture courses. Open entry/exit, so may be added anytime during the semester. This is a pass/no pass course. Also listed as ART 108 and CSIS 108. May be repeated three times for credit. ADVISORY: CSIS 1 or CSIS 2/2L or equivalent computer experience.

80121 Lab LI128 Beede R 7.60 .5 MTWR 1000A-1145A
07/07/08 - 07/31/08

80287 Lab LI128 Beede R 7.60 .5 MTWR 1200P-0145P
07/07/08 - 07/31/08

ENGLISH

ENGL 1A Composition

Transferable: CSU, UC; CSU-GE:A2; IGETC:1A; GAV-GE:A2; CAN:ENGL2, ENGL SEQ A

This is a writing course which emphasizes expository writing, argumentative writing, and critical reading of expository prose. It is meant to train students in clear thinking and reasoned support of ideas. Students will be given the opportunity to read models of good expository and argumentative prose and learn the techniques of good writing. These include choosing appropriate subjects, developing restricted, unified, and precise theses and presenting supporting evidence in a logical, lucid, and effective manner. To achieve this end, students write no fewer than six essays and read at least five works, two of which are book length. PREREQUISITE: English 250 and English 260 or English 250 and SSCI 270A or English 250 and SSCI 270B with a grade of 'C' or better or satisfactory score on the English placement examination.

80003 Lec AR103 Parker V 9.20 3.0 MTWR 0800A-1005A

80004 Online N/A Crook E 3.0
This online class will be delivered entirely over the Internet. After enrolling, start the class by going to <http://www.gavilan.edu/disted>, and log into the system. Students who have not logged in by 5 pm on the 3rd day may be dropped from the class.

80009 Lec MHG3 McMillen J 9.20 3.0 MTWR 1030A-1235P
Above class meets at Morgan Hill Community site.

80011 Online N/A Crook E 3.0
This online class will be delivered entirely over the Internet. After enrolling, start the class by going to <http://www.gavilan.edu/disted>, and log into the system. Students who have not logged in by 5 pm on the 3rd day may be dropped from the class.

80013 Lec HOL1 Mora G 6.75 3.0 MWR 0630P-0835P
06/16/08 - 08/07/08 Above class meets at the Hollister Briggs site.

CRN Type Room Instructor Hrs. Units Days Begin-End

ENGL 1B Composition and Literature

Transferable: CSU, UC; CSU-GE:C; IGETC:3B; GAV-GE:C2; CAN:ENGL4, ENGL SEQ A

English 1B continues the work begun in 1A, but now the emphasis shifts to writing expository prose in conjunction with reading and analyzing imaginative literature. Students are to write as fledgling critics and use the text as a basis for other forms of reflection. The reading requirement includes short stories, poetry, drama, and at least two novels. Course work will also include fundamentals of research writing. PREREQUISITE: English 1A with a grade of "C" or better.

80017 Lec HU105 Brett T 9.20 3.0 MTWR 0800A-1005A

80021 Online N/A Hull K 3.0
 06/16/08 - 08/08/08 This online class will be delivered entirely over the Internet. After enrolling, start the class by going to <http://www.gavilan.edu/disted>, and log into the system. Students who have not logged in by 5 pm on the 3rd day may be dropped from the class.

80024 Online N/A Raimondo J 3.0
 06/16/08 - 08/08/08 This online class will be delivered entirely over the Internet. After enrolling, start the class by going to <http://www.gavilan.edu/disted>, and log into the system. Students who have not logged in by 5 pm on the 3rd day may be dropped from the class.

ENGL 1C Critical Reasoning and Writing

Transferable: CSU, UC; CSU-GE:A3; IGETC:1B; GAV-GE:C2

This course is designed to develop critical thinking, reading, and writing skills beyond the level achieved in English 1A. The emphasis is on critical analysis of arguments and the development of the ability to integrate the principles of critical thinking into essay writing. PREREQUISITE: English 1A with a grade of "C" or better.

80025 Lec HU105 Brett T 9.20 3.0 MTWR 1030A-1235P

80027 Online N/A Candelaria X 3.0
 This online class will be delivered entirely over the Internet. After enrolling, start the class by going to <http://www.gavilan.edu/disted>, and log into the system. Students who have not logged in by 5 pm on the 3rd day may be dropped from the class.

ENGL 10 Writing for the Workplace

Transferable: CSU

This course will introduce students to the field of technical writing. Students will learn industry standards of writing as well as copyediting, outlining, and revision techniques. Various types of technical communication will be examined for consistency, completeness, economy, and accuracy. PREREQUISITE: Eligible for English 250. ADVISORY: CSIS 126, Word Processing - MS Word, or equivalent.

80028 Lec SS206 Gardner L 9.00 3.0 MWR 0630P-0920P

ENGL 250 Practical Writing

Transferable: No; GAV-GE:A2

This course covers writing clear, correct, effective essays and learning preliminary research skills. PREREQUISITE: English 440 or ESL 563 with a grade of 'C' or better or satisfactory score on the English placement examination.

80031 L/L PB5 Gardner L 9.20 3.0 MTWR 0800A-1005A
 06/16/08 - 08/08/08

80033 L/L SS205 Gatewood J 9.20 3.0 MTWR 1100A-0105P
 06/16/08 - 08/07/08

80034 L/L SS205 Wisdom K 9.20 3.0 MTWR 0600P-0805P
 06/16/08 - 08/07/08

ENGL 260 Preparation for College Reading

Transferable: No; GAV-GE:A3

This is a course presenting strategies in the technique and practice of college level critical reading and thinking skills. PREREQUISITE: Completion of English 420 or ESL 562 with a grade of 'C' or better or Assessment recommendation.

80037 Lec BU118 Luoma D 6.80 3.0 MTWR 0800A-0925A
 06/16/08 - 08/07/08

CRN Type Room Instructor Hrs. Units Days Begin-End

ENGL 420 Reading Improvement

Transferable: No

This is a practical, "how to" course teaching various methods of learning and reading college material. Using group and individual instruction in vocabulary, comprehension, and study skills, the students will increase their ability to survive academically, to profit, grow and succeed in all college courses, and to enjoy reading and learning. Units earned in this course do not count toward the associate degree and/or certain certificate requirements. PREREQUISITE: Satisfactory score on the English placement examination.

80043 L/L SS205 Withers M 9.20 3.0 MTWR 0800A-1005A
 06/16/08 - 08/07/08

ENGL 440 Basic Writing

Transferable: No

This is an intensive study and application of basic grammar, sentence, and essay writing skills within the context of composing short essays. Units earned in this course do not count toward the associate degree and/or certain certificate requirements. PREREQUISITE: Satisfactory score on the English placement examination.

80044 L/L CJ500 Luoma D 9.20 3.0 MTWR 1100A-0105P
 06/16/08 - 08/07/08

ENGLISH AS A SECOND LANGUAGE

All new ESL students must go through the ESL assessment process. See page 134.

Todos los nuevos estudiantes de ESL deben tomar el examen de nivelación de ESL. Consulte la página 134.

ESL 501B Survival ESL I Second Half

Transferable: No

This is a second half of a course in survival English for students with little or no oral or written English competency. It will give students basic vocabulary and familiarity in life skill areas such as the family, food, health, and occupations. The course integrates listening, speaking, reading, and writing. (ESL 501, 502, and 503 are sequential courses that may be taken in full form or in halves, preferably A before B.) This is a pass/no pass course. ADVISORY: ESL 501A or ESL assessment recommendation

80046 L/L LI100 Guzman D 14.40 3.0 MTWR 0900A-1220P



Have you met the prerequisite?
It's required!

CRN Type Room Instructor Hrs. Units Days Begin-End

ESL 502B Survival ESL II Second Half

Transferable: No

This is the second half of the second course in survival English for students with little oral or written English competency. It will give students expanded basic vocabulary and familiarity in life skill areas such as weather, transportation, employment, and American holidays and customs. The course integrates listening, speaking, reading, writing. (ESL 501, 502, and 503 are sequential courses that may be taken in full form or in halves, preferably A before B.) This is a pass/no pass course. ADVISORY: ESL 501 or ESL 501A and 501B or ESL assessment recommendation

80049 L/L HU104 Baameur K 14.40 3.0 MTWR 0900A-1220P

ESL 581 ESL Pronunciation I

Transferable: No

This is a high-beginning/low-intermediate ESL Pronunciation Course. Students will participate in a variety of communicative activities designed to improve their pronunciation. This course focuses on clear pronunciation of vowels, consonants, diphthongs and clusters, accurate word stress and rhythm, and the connection between spelling and pronunciation. It also introduces the concept of sentence intonation. This is a pass/no pass course. ADVISORY: ESL 510B or ESL Assessment Test Recommendation.

80050 L/L BU119 Polizzotto J 6.00 2.0 MWF 0900A-1100A

ESL 582 ESL Pronunciation II

Transferable: No

ESL Pronunciation II is the second in a series of courses designed to give ESL students extra practice with their pronunciation. After reviewing vowel and consonant sounds, students will approach pronunciation through use of word stress, sentence rhythm, and discourse intonation. This is a pass/no pass course. ADVISORY: ESL 531, ESL 581, or ESL assessment recommendation.

80052 L/L BU119 Polizzotto J 6.00 2.0 MWF 1145A-0145P

GEOLOGY

GEOL 1 Introduction to Geology

Transferable: CSU, UC; CSU-GE:B3, B1; IGETC:5A; GAV-GE:B1, B3; CAN:GEOL2

A study of the earth and the physical properties which modify the earth; minerals, rocks, geologic structures and processes. ADVISORY: Eligible for English 250 and English 260.

80156 L/L PB12 Willahan D 20.00 4.0 MTWR 0900A-0200P

GUIDANCE

GUID 1 Self-Assessment and Career Development

Transferable: CSU; CSU-GE:E2; GAV-GE:E2

This course is designed to assist the student in learning more about personal values, personality, interests, exploration of career choice, and occupational opportunities through the use of various personal assessment instruments. The delivery options for this course also include online and self-paced formats. This course is also listed as PSYC 5. ADVISORY: Eligible for English 250 and English 260. \$12 fee will be charged for career assessment materials.

80006 Online N/A Sharboneau R 2.0
 This online class will be delivered entirely over the Internet. After enrolling, start the class by going to <http://www.gavilan.edu/disted>, and log into the system. Students who have not logged in by 5 pm on the 3rd day may be dropped from the class.

80020 Online N/A Stewart J 2.0
 This online class will be delivered entirely over the Internet. After enrolling, start the class by going to <http://www.gavilan.edu/disted>, and log into the system. Students who have not logged in by 5 pm on the 3rd day may be dropped from the class.

**Campus under construction
 ROOM NUMBERS MAY CHANGE!**

Check room number online before your first class.

CRN Type Room Instructor Hrs. Units Days Begin-End

GUID 6 Life Skills for Higher Education

Transferable: CSU, UC; CSU-GE:E2; GAV-GE:E2

Evaluation and application of academic study methods to achieve subject matter mastery. Development of critical thinking skills, and application of reading, writing, note taking and test taking methods to improve personal strategies. Exploration of personal lifestyle and health factors, including the causes and management of stress, as it relates to academic success. Assessment of academic and career goals, selection of majors, and development of education plans. Topics covered include creative and realistic goal setting, academic and life management, college and community resources, library and Internet use, time management, and techniques to reduce math and science anxiety. This class will address a multitude of cultural learning styles, with emphasis on attaining professional, personal and academic goals in a diverse society. Topics from developmental psychology, learning theory and personality theory. ADVISORY: Eligible for English 250 and English 260.

80036 Online N/A Marquez C 2.0
 This online class will be delivered entirely over the Internet. After enrolling, start the class by going to <http://www.gavilan.edu/disted>, and log into the system. Students who have not logged in by 5 pm on the 3rd day may be dropped from the class.

80272 Lec APE120/12 Lopez A 6.00 2.0 TWR 0830A-1030A

GUID 200 Planning College Success

Transferable: No; GAV-GE:E2

Course is designed to enable students to plan a successful college experience. Content includes degree, major, graduation and transfer requirements. Skills necessary for academic success are presented and practiced. Students will learn general principles about libraries and the search for information. College support services will be identified and utilized during the course. This is a variable unit course; students will earn .5 unit of credit for every 9 hours of participation.

80261 Lec APE120/12 Palacios L 6.00 .5 MTWR 1030A-1145A
 This class is recommended for students participating in the TRIO Summer Bridge Program. Students are encouraged to also take CMUN 10, CRN 80091. See ad on page 21.

GUID 250 Supervised Tutoring

Transferable: No

Laboratory class emphasizing college learning skills, appropriate study techniques, and learning assistance utilizing one-on-one or small group tutorial. Guid 250 is a non-credit class and will not appear on a student's transcript.

80100 Lab LI120	TBA	Writing Center
80103 Lab LI116	TBA	Tutoring Center
80107 Lab LI116	TBA	Tutoring Center
80109 Lab LI168	TBA	Computer Place
80110 Lab PB14	TBA	Math Lab

GUID 557 Learning Skills Assessment

Transferable: No

This course provides an assessment of the students' cognitive/perceptual abilities and basic skills academic achievement. The assessment results are used to determine the students' eligibility for Learning Disabilities Services, to develop individual educational plans, and/or to improve the students' understanding of their own learning strengths and weaknesses. The assessment is conducted on a one-to-one basis by appointment. Units earned in this course do not count toward the associate degree and/or certificate requirements. This is a pass/no pass course.

80123 Lab LI114 TBA .5 Day/Time - see instructor

GUID 558 Learning Skills Laboratory

Transferable: No

The Learning Skills Laboratory is designed to assist students who are eligible to receive Learning Disabilities Services and/or have demonstrated academic deficits. The course content is individualized and based on Student Educational Contracts which are developed for each student. Students receive supplemental instruction, academic support, and learning strategy suggestions appropriate for their individual cognitive, perceptual, and academic strengths and weaknesses. Units earned do not count towards the associate degree and/or certificate requirements. This is a pass/no pass course. ADVISORY: Completion of Guidance 557 or demonstrated academic deficit.

80126 Lab LI116 Overson R .5 Day/Time - see instructor

CRN Type Room Instructor Hrs. Units Days Begin-End

HISTORY

HIST 1 United States History through Reconstruction

Transferable: CSU, UC; CSU-GE:D6, C2; IGETC:3B, 4F, 7B; GAV-GE:C2, D2; CAN:HIST8, HIST SEQ B

History of the United States from the time before European contact with the Americas through Reconstruction. Emphasis will be placed on distinctive patterns of political, economic, social, intellectual, and geographic developments within their global context. At the conclusion of the course, the student should understand major themes in the history of the United States, and be able to explain various ways in which ideas about federal vs. state power, ethnicity, class, and gender divisions have influenced the nation's development. This course has the option of a letter grade or pass/no pass. ADVISORY: Eligible for English 250 and English 260.

80187 Lec SS210 Wood D 9.20 3.0 MTWR 1030A-1235P

HIST 2 United States History Reconstruction to the Present

Transferable: CSU, UC; CSU-GE:D6, C2; IGETC:7B, 3B, 4F; GAV-GE:D2, C2; CAN:HIST10, HIST SEQ B

History of the United States from Reconstruction to the present. Emphasis will be placed on distinctive patterns of political, economic, social, intellectual, and geographic developments within their global context. At the conclusion of the course, the student should understand major themes in the history of the United States, and be able to explain various ways in which ideas about federal vs. state power, ethnicity, class, and gender divisions have influenced the nation's development. This course has the option of a letter grade or pass/no pass. ADVISORY: Eligible for English 250 and English 260.

80189 Lec SS210 Wood D 9.20 3.0 MTWR 0800A-1005A

80190 Lec SS210 Kier D 9.00 3.0 MWR 0600P-0850P

HUMANITIES

HUM 25A Film Production

Transferable: CSU, UC

In this class students are introduced to basic theory, concepts, and practice of video and film production, both in the studio and in the field. Students learn skills in camera operation, lighting, audio, and editing. Students will learn the tools of the narrative film/video director's art. Working in production groups, students learn to break down scripted material in order to prepare to shoot dramatic scenes and sequences on camera. Students learn techniques for working with actors on camera. Students apply production planning and management skills. Students learn the basics of production lighting design, including script analysis, basic 3 point lighting, fill, key, differences between perceived light, and recorded light (video, film). Students learn the basics of production sound design, including the recording of sound, foley, looping, and postproduction.

80235 L/L TBA Richards G 3.0
Mandatory class orientation will be held on June 16 in PB5 at 6:00 pm.

JAPANESE

JPN 1A Elementary Japanese

Transferable: CSU, UC; CSU-GE:C2; GAV-GE:C2

Beginning course with emphasis on understanding and speaking Japanese; introduction to reading and writing Japanese. This course will also introduce students to Japanese culture and institutions. This course has the option of a letter grade or pass/no pass.

80247 L/L SS216 Sakai T 19.20 5.0 MTWR 1250P-0520P

LIBRARY

LIB 3 Research Skills

Transferable: CSU

Research and evaluation skills using the Internet and other electronic resources, as well as traditional printed materials. Also listed as CSIS 3. This course has the option of a letter grade or pass/no pass. May be repeated once for credit. ADVISORY: Eligible for English 250 and 260.

80133 Online N/A Young D 2.0
06/16/08 - 08/08/08 This online class will be delivered entirely over the Internet. After enrolling, start the class by going to <http://www.gavilan.edu/disted>, and log into the system. Students who have not logged in by 5 pm on the 3rd day may be dropped from the class.



CRN Type Room Instructor Hrs. Units Days Begin-End

LIB 6 Web Page Authoring I

Transferable: CSU; GAV-GE:E2

An introduction to using Hypertext Mark-Up Language (HTML) and Extensible HTML (XHTML) to create web pages which can be uploaded and displayed on the World Wide Web. Students will use HTML/XHTML to create web pages with text in various sizes and colors, links to other sites, background color or patterns, graphics, tables, and mailto links. Principles of design and color as they apply to screen presentations will be included. This course has the option of a letter grade or pass/no pass. May be repeated three times for credit. Also listed as CSIS 6 and DM 6. ADVISORY: CSIS 1 or CSIS 2 or CSIS/LIB 3 advised.

80026 Lec MHG8 Van Tassel D 9.00 2.0 MWR 0410P-0700P
06/16/08 - 07/10/08 Above class meets at Morgan Hill Community site.

MATHEMATICS

MATH 5 Introduction to Statistics

Transferable: CSU, UC; CSU-GE:B4; IGETC:2A; GAV-GE:B4; CAN:STAT2

Descriptive analysis and presentation of either single-variable data or bivariate data, probability, probability distributions, normal probability distributions, sample variability, statistical inferences involving one and two populations, analysis of variance, linear correlation and regression analysis. Statistical computer software will be extensively integrated as a tool in the description and analysis of data. PREREQUISITE: Mathematics 233 with a grade of 'C' or better. The instructor will be using and supporting a TI-83 Plus graphing calculator in all classroom demonstrations.

80160 Lec SS206 Butterworth Y 12.00 3.0 MTWR 0100P-0350P

80163 Lec MHG3 Viarengo A 12.00 3.0 MTWR 0600P-0850P
Above class meets at Morgan Hill Community site.

MATH 8A First Half of Precalculus

Transferable: CSU, UC; CSU-GE:B4; IGETC:2A; GAV-GE:B4

Math 8A prepares the student for the study of calculus by providing important skills in algebraic manipulation, interpretation, and problem solving at the college level. Topics will include basic algebraic concepts, complex numbers, equations and inequalities of the first and second degree, functions, and graphs, linear and quadratic equations, polynomial functions, exponential and logarithmic functions, systems of equations, matrices and determinants, right triangle trigonometry, and the Law of Sines and Cosines. PREREQUISITE: Mathematics 233 with a grade of 'C' or better. The instructor will be using and supporting TI-83 Plus graphing calculator in all classroom demonstrations.

80165 Lec PB13 Lee R 12.00 4.0 MTWR 0900A-1140A



New to college?
Start out on the right foot by taking ...

GUIDE life skills
for higher education

... and learn success strategies such as study skills, goal setting and time management!

2 units

Fulfills Gavilan general education and CSU transfer requirements and is UC transferable.



CRN Type Room Instructor Hrs. Units Days Begin-End

MATH 205 Elementary Algebra

Transferable: No; GAV-GE:B4

This course is a standard beginning algebra course, including algebraic expressions, linear equations and inequalities in one variable, graphing, equations and inequalities in two variables, integer exponents, polynomials, rational expressions and equations, radicals and rational exponents, and quadratic equations. Mathematics 205, 205A and 205B, and 206 have similar course content. This course may not be taken by students who have completed Mathematics 205B or 206 with a grade of "C" or better. This course may be taken for Mathematics 205B credit (2.5 units) by those students who have successfully completed Mathematics 205A with a grade of "C" or better. PREREQUISITE: MATH 402 with a grade of 'C' or better or assessment test recommendation.

80166	Lec	PB3	Nari J	14.00	5.0	MTWR	0830A-1145A
80168	Lec	HOL4	Wagman K	14.50	5.0	MTWRF	1100A-0145P

Above class meets at the Hollister Briggs site.

MATH 205B Second Half of Elementary Algebra

Transferable: No; GAV-GE:B4

This course contains the material covered in the second half of the Elementary Algebra Course. It will cover factoring, polynomials, solving quadratic equations by factoring, rational expressions and equations, complex fractions, radicals and radical equations, solving quadratic equations by completing the square and the quadratic formula. Application problems are integrated throughout the topics. PREREQUISITE: Math 205A with a grade of 'C' or better. ADVISORY: Concurrent enrollment in Guidance 563B is advised.

80169	Lec	PB8	Lockhart L	12.00	2.5	MTWR	1000A-1240P
-------	-----	-----	------------	-------	-----	------	-------------

MATH 208 Plane Geometry

Transferable: No

This course introduces the vocabulary and principles of Euclidean Geometry. Methods of proof including inductive and deductive reasoning will be developed. Concepts of congruence and similarity, angles, lines, polygons, and circles will be covered. Additional topics such as solid geometry, analytical geometry, transformations, and basic trigonometry may be included as time allows. PREREQUISITE: Math 205 or Math 205A and Math 205B with a grade of 'C' or better.

80173	Lec	PB9	Maisch F	9.20	3.0	MTWR	0900A-1105A
-------	-----	-----	----------	------	-----	------	-------------

MATH 233 Intermediate Algebra

Transferable: No; GAV-GE:B4

Review of basic concepts, linear equations and inequalities, graphs and functions, systems of linear equations, polynomials and polynomial functions, factoring, rational expressions and equations, roots, radicals, and complex numbers, solving quadratic equations, exponential and logarithmic functions, and problem solving strategies. Mathematics 233, 233A, and 233B have similar course content. This course may not be taken by students who have completed Mathematics 233B with a grade of 'C' or better. This course may be taken for Mathematics 233B credit (2.5 units) by those students who have successfully completed Mathematics 233A with a grade of 'C' or better. PREREQUISITE: Mathematics 205 or Mathematics 205A and 205B or Mathematics 206 with a grade of 'C' or better. The instructor will be using and supporting TI-83 Plus graphing calculator in all classroom demonstrations.

80175	Lec	HOL4	Wagman K	15.00	5.0	MTWRF	0810A-1050A
Above class meets at the Hollister Briggs site.							
80177	Lec	MHG13	Butterworth Y	14.00	5.0	MTWR	0830A-1145A
Above class meets at Morgan Hill Community site.							
80283	Lec	PB3	Dresch M	14.00	5.0	MTWR	0100P-0415P

MATH 402 Pre-Algebra

Transferable: No

This course covers operations with integers, fractions and decimals and associated applications, percentages, ratio, and geometry and measurement, critical thinking and applications. Elementary algebra topics such as variables, expressions, and solving equations are introduced. PREREQUISITE: Completion of Math 400 with a 'C' or better, or assessment test recommendation.

80178	L/L	SS206	Kercheval S	12.00	3.0	MTWR	0830A-1120A
-------	-----	-------	-------------	-------	-----	------	-------------

CRN Type Room Instructor Hrs. Units Days Begin-End

PHYSICAL EDUCATION: ACTIVITIES

PE 16 Swimming

Transferable: CSU, UC; CSU-GE:E1; GAV-GE:E1

Coeducational activity designed for all skill levels. The course teaches the techniques of a variety of strokes and includes conditioning activities. Instruction is tailored to meet individual and group needs. May be repeated three times for credit. This course has the option of a letter grade or pass/no pass.

80002	Lab	GY100P	Lango J	8.00	1.0	MTWR	1115A-0115P
-------	-----	--------	---------	------	-----	------	-------------

PE 17 Golf

Transferable: CSU, UC; CSU-GE:E1; GAV-GE:E1

Coeducational activity designed for all skill levels; fundamentals, techniques, rules and etiquette of golf. May be repeated three times for credit. This course has the option of a letter grade or pass/no pass.

80284	Lab	ERGOLF	Krause S	3.40	.5	S	0900A-1210P
Class meets at Eagle Ridge Golf Club. Students will pay approximately \$20 in ball/equipment rental.							

PE 21 Volleyball

Transferable: CSU, UC; CSU-GE:E1; GAV-GE:E1

Coeducational activity designed for beginning and intermediate volleyball students; rules, strategy and fundamentals of volleyball. May be repeated three times for credit. This course has the option of a letter grade or pass/no pass.

80094	Lab	GY131G	Kramer K	11.20	.5	MTWR	0900A-1130A
07/21/08 - 08/14/08							

PE 24 Individualized Weight Training

Transferable: CSU, UC; CSU-GE:E1; GAV-GE:E1

An open laboratory for those who desire an individualized strength program using exercise machines and free weights. May be repeated three times for credit. This course has the option of a letter grade or pass/no pass.

Students enrolling in the following classes should check in the first three days of summer session at the Fitness Center (GY123) during lab hours (Mon - Fri, 7 am - 1 pm).

80098	Lab	GY123	Dodd S		.5	Day/Time	See instructor
80105	Lab	GY123	Dodd S		1.0	Day/Time	See instructor

PE 25 Soccer

Transferable: CSU, UC; CSU-GE:E1; GAV-GE:E1

Co-educational activity designed for all skill levels. Fundamentals, strategy and rules of the game are included. May be repeated three times for credit. This course has the option of a letter grade or pass/no pass.

80115	Lab	GY131G	Marques A	11.20	.5	MTWR	0300P-0530P
07/28/08 - 08/14/08							

PE 27 Basketball

Transferable: CSU, UC; CSU-GE:E1; GAV-GE:E1

Co-educational activity designed for all skill levels. Fundamentals, strategy and rules of the game are included. May be repeated three times for credit. This course has the option of a letter grade or pass/no pass.

80282	Lab	GY131G	Addison T	4.80	.5	TR	0330P-0530P
-------	-----	--------	-----------	------	----	----	-------------

**SUMMER
SPORTS CAMPS
FOR KIDS!**

See ad on page 38.



CRN Type Room Instructor Hrs. Units Days Begin-End

PE 37 Softball

Transferable: CSU, UC; CSU-GE:E1; GAV-GE:E1

Coeducational activity designed for all skill levels. Rules, fundamentals, and strategy and game play will be included. May be repeated three times for credit. This course has the option of a letter grade or pass/no pass.

80117 Lab GY131G Dequin N 8.40 1.0 MWR 0130P-0400P

PE 46 Agility and Motor Development

Transferable: CSU, UC; CSU-GE:E1; GAV-GE:E1

An activity class designed to improve and increase agility and motor development through various exercise and exercise programs. May be repeated three times for credit. This course has the option of a letter grade or pass/no pass.

80154 Lab GY131G Lango J 8.00 1.0 MTWR 0300P-0500P

PE 61 Swim for Fitness

Transferable: CSU, UC; CSU-GE:E1; GAV-GE:E1

Designed to develop endurance and swimming skills in order to maintain good cardiovascular/physical fitness. Intermediate swimming ability recommended. May be repeated three times for credit. This course has the option of a letter grade or pass/no pass.

80155 Lab GY100P Dodd S 4.00 .5 TR 0530P-0730P

PE 62 Yoga

Transferable: CSU, UC; CSU-GE:E1; GAV-GE:E1

Co-educational activity designed for beginning yoga students. A program designed to improve flexibility and reduce stress, by learning a series of postures and focusing on proper breathing techniques. May be repeated three times for credit. This course has the option of a letter grade or pass/no pass.

80159 Lab APE101 Muscari D 4.00 .5 TR 0100P-0300P

80164 Lab APE101 Muscari D 4.80 .5 TR 0530P-0730P

PE 64 Individualized Cardiovascular Fitness

Transferable: CSU, UC; CSU-GE:E1; GAV-GE:E1

A fitness program which develops cardiovascular endurance through an individualized open lab format. May be repeated three times for credit. This course has the option of a letter grade or pass/no pass.

Students enrolling in the following classes should check in the first three days of summer session at the Fitness Center (GY123) during lab hours (Mon - Fri, 7 am - 1 pm).

80171 Lab GY123 Dodd S .5 Day/Time See instructor

80181 Lab GY123 Dodd S 1.0 Day/Time See instructor

PE 65 Baseball

Transferable: CSU, UC; CSU-GE:E1; GAV-GE:E1

Course designed for students who desire to learn the fundamentals, mechanics, strategy, history and rules of the game of competitive baseball. Course is designed for students of all skill levels, ages, and both genders who wish to play or coach youth baseball. This course has the option of a letter grade or pass/no pass. May be repeated three times for credit.

80194 Lab GY131G Andrade N 8.40 1.0 MWR 0130P-0400P

PE 70 Pilates

Transferable: CSU, UC; CSU-GE:E1; GAV-GE:E1

This class utilizes the Pilates exercise system focused on improving flexibility and strength for the total body through a series of controlled movements. May be repeated three times for credit. This course has the option of a letter grade or pass/no pass.

80198 Lab APE101 Muscari D 4.00 .5 MW 0100P-0300P



Come out and be part of Gavilan College **Men's Soccer!**

After a successful first year, Gavilan Men's Soccer is back with high expectations.

Be part of it!

PE 24 Individualized Weight Training
PE 64 Cardiovascular Fitness

Summer Session Fitness Center Lab Hours
MTWThF 7:00 am - 1:00 pm



Section hours by arrangement

- ✦ 1.5 to 3 weekly hours
- ✦ .5 or 1.0 unit
- ✦ Fitness Center (GYM 123)

Open Lab Class Format
Designed for individualized strength or cardiovascular fitness programs in an open lab setting using a variety of exercise equipment.

Students should check in during the first three days of the summer session during lab hours.

Math 208 - Summer Session
3 Units
pre-requisite for Math 12
recommended for calculus

Plane Geometry

Geometry

CRN# 80173 Mon-Thurs 9:00 - 11:05 am



Appropriate footwear is required in all gym facilities. No barefeet permitted.

CRN	Type	Room	Instructor	Hrs.	Units	Days	Begin-End
PE 75 Sports Conditioning							
Transferable: CSU, UC; CSU-GE:E1; GAV-GE:E1							
This activity class is designed to improve the physical condition of male and female athletes. It includes strength training, cardiovascular endurance, plyometric training, and sport specific techniques. May be repeated three times for credit. This course has the option of a letter grade or pass/no pass.							
Students enrolling in the following classes should check in the first three days of summer session at the Fitness Center (GY123) during lab hours (Mon - Fri, 7 am - 1 pm).							
80203	Lab	GY123	Dodd S		.5		
80206	Lab	GY123	Dodd S		1.0		

CRN	Type	Room	Instructor	Hrs.	Units	Days	Begin-End
PE 36 Adapted Physical Education							
Transferable: CSU, UC; CSU-GE:E1; GAV-GE:E1							
An individualized program of adaptive physical education activities designed to meet the needs of students with physical disabilities. Develops an appreciation of physical activity as a regular planned contribution to one's overall well-being. May be repeated as necessary based on measurable progress as documented in the student's educational contract. This course has the option of a letter grade or pass/no pass.							
80056	Lab	APE108	Ellis D		3.00	.5 MTWR	0945A-1030A 06/02/08 - 07/24/08

PHYSICAL EDUCATION: ADAPTED

PE 34 Adapted Aquatic Exercise							
Transferable: CSU, UC; CSU-GE:E1; GAV-GE:E1							
Designed to help individuals who by the nature of their disability such as wheelchair use, back injury, cardiovascular impairment, multiple sclerosis or other disabling condition require a specific aquatic exercise program that will contribute to their physical well-being. May be repeated as necessary based on measurable progress as documented in the student's educational contract. This course has the option of a letter grade or pass/no pass.							
80041	Lab	GY100P	Ellis D	3.00	.5	MTWR	0815A-0900A 06/02/08 - 07/24/08
80042	Lab	GY100P	Ellis D	3.00	.5	MTWR	1045A-1130A 06/02/08 - 07/24/08
80045	Lab	GY100P	Ellis D	3.00	.5	MTWR	1145A-1230P 06/02/08 - 07/24/08

PE 38 Adapted Cardiovascular Conditioning/Training							
Transferable: CSU, UC; CSU-GE:E1; GAV-GE:E1							
Prescribed exercises in weight training, stretching and cardiovascular conditioning for those individuals that have been disabled through stroke, cardiovascular accident, arthritis, multiple sclerosis, or other condition. May be repeated as necessary based on measurable progress as documented in the student's educational contract. This course has the option of a letter grade or pass/no pass.							
80058	Lab	APE108	Ellis D	3.00	.5	MTWR	0945A-1030A 06/02/08 - 07/24/08

PE 35 Adapted Swimming for Total Fitness							
Transferable: CSU, UC; CSU-GE:E1; GAV-GE:E1							
An individualized program of activities designed for students with physical disabilities to improve flexibility and range-of-motion, increase joint movement, improve circulation, and improve control of body movement through water adjustment and activities. Develops an appreciation of physical activity as a regular planned contribution to one's overall well-being. May be repeated as necessary based on measurable progress as documented in the student's educational contract. This course has the option of a letter grade or pass/no pass.							
80048	Lab	GY100P	Ellis D	3.00	.5	MTWR	0815A-0900A 06/02/08 - 07/24/08
80053	Lab	GY100P	Ellis D	3.00	.5	MTWR	1045A-1130A 06/02/08 - 07/24/08
80054	Lab	GY100P	Ellis D	3.00	.5	MTWR	1145A-1230P 06/02/08 - 07/24/08

PE 534 Adapted Aquatic Exercise							
Transferable: No							
Designed to help individuals who by the nature of their disability such as wheelchair use, back injury, cardiovascular impairment, multiple sclerosis or other disabling condition require a specific aquatic exercise program that will contribute to their physical well being. May be repeated as necessary based on measurable progress as documented in the student's educational contract. This is a pass/no pass course.							
80062	Lab	GY100P	Ellis D	3.00	.5	MTWR	0815A-0900A 06/02/08 - 07/24/08
80064	Lab	GY100P	Ellis D	3.00	.5	MTWR	1045A-1130A 06/02/08 - 07/24/08
80066	Lab	GY100P	Ellis D	3.00	.5	MTWR	1145A-1230P 06/02/08 - 07/24/08

PE 535 Adapted Swimming for Total Fitness							
Transferable: No							
An individualized program of activities designed for students with physical disabilities to improve flexibility and range-of-motion, increase joint movement, improve circulation, and improve control of body movement through water adjustment and activities. Develops an appreciation of physical activity as a regular planned contribution to one's overall well-being. May be repeated as necessary based on measurable progress as documented in the student's educational contract. This course is pass/no pass.							
80080	Lab	GY100P	Ellis D	3.00	.5	MTWR	0815A-0900A 06/02/08 - 07/24/08
80081	Lab	GY100P	Ellis D	3.00	.5	MTWR	1045A-1130A 06/02/08 - 07/24/08
80082	Lab	GY100P	Ellis D	3.00	.5	MTWR	1145A-1230P 06/02/08 - 07/24/08

Summer Final Exams

are the last day of each class.



Sports Camps

Gavilan College Community Education
For Registration: <http://gavilan.augusoft.net>
For more info: (408) 848-4876

Softball Camp (Ages 8-13)
Mon, Tues, Wed, Thurs, Fri
9:00 AM - 12:00 PM; 5 sessions
starting June 23, 2008, ending June 27, 2008
Gavilan College Softball Field \$99

Basketball Camp (Ages 8-17)
Fri, Sat, Sun
9:00 AM - 12:00 PM; 3 sessions
starting June 27, 2008, ending June 29, 2008
Bill Christopher Court-Main Gym. \$65

Soccer Camp (Ages 8-17)
Mon, Tues, Wed, Thurs, Fri
9:00 AM - 12:00 PM; 5 sessions
starting July 14, 2008, ending July 18, 2008
Gavilan Sports Complex \$99

Baseball Camp (Ages 8-13)
Mon, Tues, Wed, Thurs, Fri
9:00 AM - 12:00 PM; 5 sessions
starting July 14, 2008, ending July 18, 2008
Gavilan College Baseball Field \$99

Volleyball Camp (Ages 8-13)
Mon, Tues, Wed, Thurs
9:00 AM - 11:00 AM; 4 sessions
starting July 14, 2008, ending July 17, 2008
Bill Christopher Court-Main Gym. \$89

Football Camp (Ages 8-13)
Mon, Tues, Wed, Thurs, Fri
2:00 PM - 4:00 PM; 5 sessions
starting July 14, 2008, ending July 18, 2008
Gavilan College Football Field. \$99

CRN Type Room Instructor Hrs. Units Days Begin-End

PE 536 Adapted Physical Education

Transferable: No

An individualized program of adaptive physical education activities designed to meet the needs of students with physical disabilities. Develops an appreciation of physical activity as a regular planned contribution to one's overall well-being. May be repeated as necessary based on measurable progress as documented in the student's educational contract. This is a pass/no pass course.

80083 Lab APE108 Ellis D 3.00 .5 MTWR 0945A-1030A
06/02/08 - 07/24/08

80093 Lab LOADCS1 Maringer J 3.00 .5 MTWR 0945A-1030A
06/02/08 - 07/24/08 Above class meets off-campus: Above class meets off-campus at Live Oak Adult Day Care, 651 West Sixth Street, Gilroy.

80135 Lab APE101 Ellis D 3.30 .5 F 0945A-1250P
06/02/08 - 07/24/08

PE 538 Adapted Cardiovascular Conditioning/Training

Transferable: No

Prescribed exercises in weight training, stretching and cardiovascular conditioning for those individuals that have been disabled through stroke, cardiovascular accident, arthritis, multiple sclerosis, or other condition. May be repeated as necessary based on measurable progress as documented in the student's educational contract. This is a pass/no pass course.

80101 Lab APE108 Ellis D 3.00 .5 MTWR 0945A-1030A
06/02/08 - 07/24/08

PHILOSOPHY

PHIL 1 Introduction to Philosophy

Transferable: CSU, UC; CSU-GE:C2; IGETC:3B; GAV-GE:C2; CAN:PHIL2

Philosophy 1 is intended as a survey of the major areas and traditions of philosophy. The course examines central and significant questions about the meaning of life, who determines what is morally right or wrong, the ideal society, the various notions social justice, what is reality, and many other ideas. In pursuing these questions, students will be asked to read texts from writers around the world, both contemporary and ancient, discuss current events, and apply 'theory' to movies such as "The Matrix" trilogy, novels, and any other relevant application of the student's own choice. ADVISORY: Eligible for English 1A.

80102 Lec CJ500 Johnston M 9.20 3.0 MTWR 0800A-1005A

POLITICAL SCIENCE

POLS 1 Introduction to American Government

Transferable: CSU, UC; CSU-GE:D8; IGETC:4H, 7A; GAV-GE:D2, D1; CAN:GOVT2

Explores the development of American political institutions and their utilization in dealing with issues arising at the international, national and state levels. Emphasis is placed on those problems which have defined our federal system of government. California government and appropriate state institutions will be included as a vital part of our federal system of government. ADVISORY: Eligible for English 250 and English 260.

80191 Lec SS210 Kier D 9.20 3.0 MTWR 0230P-0435P

80193 Online N/A Turetzky M 3.0
 This online class will be delivered entirely over the Internet. After enrolling, start the class by going to <http://www.gavilan.edu/disted>, and log into the system. Students who have not logged in by 5 pm on the 3rd day may be dropped from the class.

80195 Online N/A Turetzky M 3.0
 This online class will be delivered entirely over the Internet. After enrolling, start the class by going to <http://www.gavilan.edu/disted>, and log into the system. Students who have not logged in by 5 pm on the 3rd day may be dropped from the class.

80196 Online N/A Turetzky M 3.0
 This online class will be delivered entirely over the Internet. After enrolling, start the class by going to <http://www.gavilan.edu/disted>, and log into the system. Students who have not logged in by 5 pm on the 3rd day may be dropped from the class.

Beginning with the summer 2008 enrollment period social security numbers will no longer be used as student identifiers. Find your new Gavilan Student ID and choose a log-on password by going to www.gavilan.edu and clicking on the Self-Service Banner icon. You will use your new ID and password to log into Self-Service Banner and register for summer and fall classes.

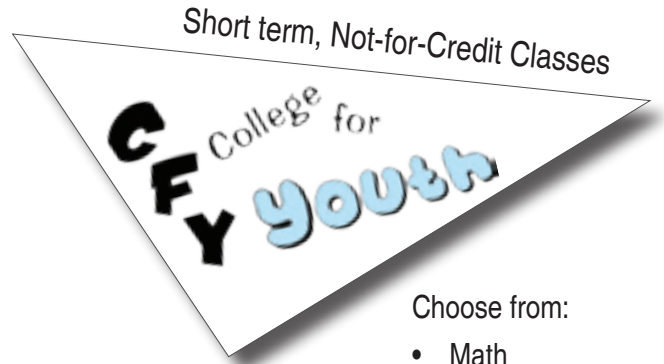

Choose from:

- Math
- Cooking
- English/Language Arts
- Study Skills
- Swimming
- Arts & Crafts
- Foreign Languages
- Science

and more!

Because each class is stand-alone, you can sign up for 1 class or 5 classes. It all depends on you!

Summer Sessions:

Session 1 7/7 - 7/17

Session 2 7/21 - 7/31; no class on Fridays

Dates subject to change. Course fees vary.



For more information call (408) 847-2514 or register online at <http://gavilan.augusoft.net>

Gavilan College's College for Youth program is operated through the Community Education Dept. The majority of our classes are offered in the summer at our main campus in Gilroy.

THERE'S A TV STATION AT GAVILAN



Community Media Access Partnership (CMAP) manages the four community TV channels in Gilroy, Hollister and San Juan Bautista. Any resident can submit a video to air, or you can learn how to use CMAP's video equipment and make a TV show.

Channel 17 City View

Channel 18 GavTV

Channel 19 EdTV

Channel 20 Public Access

INTERESTED? CHECK OUT OUR WEBSITE: WWW.MYCMAP.ORG OR DROP BY OUR FACILITY IN L-139!

CRN Type Room Instructor Hrs. Units Days Begin-End

PSYCHOLOGY

PSYC 1A Introduction to Psychology

Transferable: CSU, UC; CSU-GE:D9; IGETC:4I; GAV-GE:D2; CAN:PSY2

The nature, scope, methods, presuppositions, history, and fields of psychology together with the scientific study of factors influencing human behavior, human development, perception, learning, memory, emotion, personality, frustration, and psychotherapy. ADVISORY: Eligible for English 250 and English 260.

80197 Lec MHG4 Campilli J 9.20 3.0 MTWR 1030A-1235P
Above class meets at Morgan Hill Community site.

80199 Lec SS214 Campilli J 9.00 3.0 MWR 0600P-0850P

PSYC 2 Early Child Development

Transferable: CSU, UC; CSU-GE:D9, E; IGETC:4I; GAV-GE:D2

A systematic study of the child from prenatal life through the preschool years. The course integrates the basic concepts of physical, cognitive and psychosocial development at each major stage of life during this period. This course is also listed as CD 2. This course has the option of a letter grade or pass/no pass. ADVISORY: Eligible for English 250 and English 260.

80225 Online N/A Bumgarner M 3.0
This online class will be delivered entirely over the Internet. After enrolling, start the class by going to <http://www.gavilan.edu/disted>, and log into the system. Students who have not logged in by 5 pm on the 3rd day may be dropped from the class.

PSYC 3 Child Growth and Development During the School Years

Transferable: CSU, UC; CSU-GE:E; IGETC:4I; GAV-GE:D2

Continuation of the study of child development with emphasis on children from six years of age through adolescence. Includes developmental theories and topics relevant to these ages. This course is also listed as CD 3. This course has the option of a letter grade or pass/no pass. ADVISORY: Eligible for English 250 and English 260; Psychology 2.

80228 Online N/A Bumgarner M 3.0
This online class will be delivered entirely over the Internet. After enrolling, start the class by going to <http://www.gavilan.edu/disted>, and log into the system. Students who have not logged in by 5 pm on the 3rd day may be dropped from the class.

PSYC 5 Self-Assessment and Career Development

Transferable: CSU; CSU-GE:E2; GAV-GE:E2

A course designed to assist the student in learning more about personal values, personality, interests, exploration of career choice, and occupational opportunities through the use of various personal assessment instruments. The delivery options for this course include online and self-paced formats. This course is also listed as GUID 1. ADVISORY: Eligible for English 250 and English 260. \$12 fee will be charged for career assessment materials.

80010 Online N/A Sharboneau R 2.0
This online class will be delivered entirely over the Internet. After enrolling, start the class by going to <http://www.gavilan.edu/disted>, and log into the system. Students who have not logged in by 5 pm on the 3rd day may be dropped from the class.

80029 Online N/A Stewart J 2.0
This online class will be delivered entirely over the Internet. After enrolling, start the class by going to <http://www.gavilan.edu/disted>, and log into the system. Students who have not logged in by 5 pm on the 3rd day may be dropped from the class.

REAL ESTATE

RE 160 Real Estate Principles

Transferable: CSU

The fundamental course covering an introduction to the field of real estate. Provides understanding, background and terminology necessary for advanced specialized courses. Will meet requirements for the Real Estate Sales License. This course has the option of a letter grade or pass/no pass. ADVISORY: Eligible for English 250, English 260 and Mathematics 205.

80157 Lec MHG12 Frimann G 4.00 3.0 S 0830A-1230P
06/07/08 - 08/23/08 Above class meets at Morgan Hill Community site.

CRN Type Room Instructor Hrs. Units Days Begin-End

RE 162 Real Estate Practice

Transferable: CSU

Introduction to the practice of real estate in California; emphasis on the practical application of listings, selling, advertising, financing, escrow, taxation, and valuation of real estate. This course meets a requirement for the California o credit.License. This course has the option of a letter grade or pass/no pass. May be repeated three times for credit. ADVISORY: Real Estate 160

80161 Lec BU118 Frimann G 6.00 3.0 TR 0630P-0920P

RE 166 Property Management

Transferable: CSU

A study of techniques and practices in the management of income property from acquisition to disposal. The course will cover neighborhood analysis, rent schedules, rental finance, collections, eviction, maintenance and rehabilitation, tax considerations, depreciation and the pitfalls in the purchase of income property. This course may be used for the California Broker's License. ADVISORY: Real Estate 160

80288 Lec BU118 Banks S 6.60 3.0 MW 0600P-0905P
06/16/08 - 08/07/08

SOCIOLOGY

SOC 1A Introduction to Sociology

Transferable: CSU, UC; CSU-GE:D0; IGETC:4J; GAV-GE:D2; CAN:SOC2

Analysis of the structure and dynamics of human society focusing on the development of culture, the socialization process, group behavior, social inequality, deviance, sexism, racism, and ageism, major social institutions, and human ecology. Emphasizes contemporary American society. ADVISORY: Eligible for English 250 and English 260.

80201 Lec SS214 Kreider R 9.20 3.0 MTWR 0800A-1005A

SOC 3 Sociology of Race, Ethnicity and Cultural Identity

Transferable: CSU, UC; CSU-GE:D0; IGETC:4J; GAV-GE:F

This course is designed to introduce students to the basic sociological concepts and theories of race, ethnicity and cultural identity in U.S. society. Students will examine race, ethnicity and cultural identity as social constructs that permeate social structures and institutions, and how they change over time and space. Over the semester students will critically analyze the ways which race, ethnicity, class, and gender/sexuality continually shape peoples lives and experiences. While the class focuses on U.S. societies, students will also critically compare and contrast race and ethnicity in other societies. ADVISORY: Eligible for English 250 and English 260.

80202 Lec HOL5 Cervantes E 9.20 3.0 MTWR 0800A-1005A
Above class meets at the Hollister Briggs site.

SOC 4 Sociology of Women and Men

Transferable: CSU, UC; CSU-GE:D4, D0; IGETC:4J; GAV-GE:D2

Analysis of the nature of women's and men's traditional and changing roles in society including development of women's and men's potential, relationships in marriage, influence of mass media, employment practices, legal provisions and women's and men's liberation. ADVISORY: Eligible for English 250 and English 260.

80204 Lec SS214 Kreider R 9.20 3.0 MTWR 1030A-1235P

SPANISH

SPAN 1A Elementary Spanish

Transferable: CSU, UC; CSU-GE:C2; GAV-GE:C2; CAN:SPAN2, SPAN SEQ A

Beginning course with emphasis on understanding and speaking Spanish; introduction to reading and writing Spanish. This course will also introduce students to Hispanic culture and institutions.

80213 L/L MEXICO Perez D 5.0
06/08/08 - 07/06/08 Above class meets off-campus: Travel Study in Zacatecas, Mexico.

80215 L/L SS216 Schmidt E 25.00 5.0 MTWRF 0800A-1240P

CRN Type Room Instructor Hrs. Units Days Begin-End

SPAN 1B Elementary Spanish

Transferable: CSU, UC; CSU-GE:C2; IGETC:6A; GAV-GE:C2; CAN:SPAN4, SPAN SEQ A
Continuation of Spanish 1A. Further development of the four skills of understanding, speaking, reading and writing Spanish. This course will continue to emphasize the study of Hispanic culture and institutions. ADVISORY: Spanish 1A or equivalent.

80217 L/L MEXICO Perez D 5.0
06/08/08 - 07/06/08 Above class meets off-campus: Travel Study in Zacatecas, Mexico.

SPAN 2A Intermediate Spanish

Transferable: CSU, UC; CSU-GE:C2; IGETC:3B, 6A; GAV-GE:C2; CAN:SPAN8, SPAN SEQ B
Review of basic structures through conversation and selected works of literature. Further expansion of patterns, vocabulary and idioms. Creative expression through discussion and composition. ADVISORY: Spanish 1B or equivalent.

80219 L/L MEXICO Perez D 5.0
06/08/08 - 07/06/08 Above class meets off-campus: Travel Study in Zacatecas, Mexico.

SPAN 2B Intermediate Spanish

Transferable: CSU, UC; CSU-GE:C2; IGETC:6A, 3B; GAV-GE:C2; CAN:SPAN10, SPAN SEQ B
Review of basic structures and grammar with greater emphasis on vocabulary and idioms. Introduction to literature as it reflects the characteristics of Hispanic societies. Greater emphasis on composition as a medium of expression. ADVISORY: Spanish 2A or equivalent.

80220 L/L MEXICO Perez D 5.0
06/08/08 - 07/06/08 Above class meets off-campus: Travel Study in Zacatecas, Mexico.

SPAN 8A Conversational Spanish

Transferable: CSU; GAV-GE:C2
This course is a beginning Spanish course, focusing on the Spanish sound system, basic grammar and vocabulary, and cultural elements. Although emphasis is on listening and speaking, basic reading and writing skills will be developed.

80222 Lec MEXICO Perez D 3.0
06/08/08 - 07/06/08 Above class meets off-campus: Travel Study in Zacatecas, Mexico.

SPAN 8B Conversational Spanish

Transferable: CSU; GAV-GE:C2
This course requires knowledge of Spanish pronunciation, basic vocabulary, and present tense grammar. More advanced grammar and vocabulary, and cultural elements will be taught in the development of listening, speaking, basic reading and writing skills. ADVISORY: Spanish 8A or equivalent.

80224 Lec MEXICO Perez D 3.0
06/08/08 - 07/06/08 Above class meets off-campus: Travel Study in Zacatecas, Mexico.

SPAN 8C Conversational Spanish

Transferable: CSU; GAV-GE:C2
This course requires considerable knowledge of Spanish pronunciation, vocabulary, grammar and syntax. More advanced grammar and vocabulary will be taught in the development of listening, speaking, reading and writing skills. ADVISORY: Spanish 8B or equivalent.

80227 Lec MEXICO Perez D 3.0
06/08/08 - 07/06/08 Above class meets off-campus: Travel Study in Zacatecas, Mexico.

SPAN 8D Conversational Spanish

Transferable: CSU; GAV-GE:C2
This course requires fluency in spoken and written Spanish. Advanced grammar and vocabulary will be presented while the course concentrates on polishing the student's oral and written skills and develops a sense of style. ADVISORY: Spanish 8C or equivalent.

80229 Lec MEXICO Perez D 3.0
06/08/08 - 07/06/08 Above class meets off-campus: Travel Study in Zacatecas, Mexico.

CRN Type Room Instructor Hrs. Units Days Begin-End

SPAN 12A Spanish for Spanish Speakers

Transferable: CSU, UC; CSU-GE:C2; IGETC:6A; GAV-GE:F
Through comparative analysis of selected literary works, the course develops an awareness of cultural and literary contributions from Mexico and other Spanish speaking societies. The course is taught in Spanish with emphasis on composition as a medium of expression. ADVISORY: Basic Spanish reading and writing skills.

80289 Online N/A Perez D 5.0
06/16/08 - 08/11/08 This online class will be delivered entirely over the Internet. After enrolling, start the class by going to <http://www.gavilan.edu/disted>, and log into the system. Students who have not logged in by 5 pm on the 3rd day may be dropped from the class.

SPAN 23 Independent Study

Transferable: CSU
Designed to afford selected students specialized opportunities for exploring areas at the independent study level. The courses may involve extensive library work, research in the community, or special projects. May be repeated until six units of credit are accrued. This course has the option of a letter grade or pass/no pass. REQUIRED: The study outline prepared by the student and the instructor must be filed with the department and the dean.

80230 Ind Perez D 1.0
Above class meets off-campus:
80232 Ind Perez D 2.0
Above class meets off-campus:



Study and travel this summer!
Learn Spanish in Zacatecas, México!
June 8 - July 6

Cost:
Approximately \$1,200 plus
airfare for a
4-week program.

Earn up to 5 units
Study the language and culture while living with a host family.

For more information visit the website at www.gavilan.edu/spanish
call David Perez: (408) 848-4842
or email: dperez@gavilan.edu

Don't go to the wrong city

MHG = Morgan Hill Community Center site

HOL = Hollister Briggs Building site

CRN Type Room Instructor Hrs. Units Days Begin-End

SPAN 98 Special Topics

Transferable: CSU

Special topics courses examine current problems or issues of interest to students within a specific discipline area. For topical content information, consult with the appropriate department chairperson. For transfer status, check with a counselor. May be repeated for credit with different topics. This course may have the option of a letter grade or pass/no pass.

80234 Ind MEXICO Perez D .5
Above class meets off-campus: Travel Study in Zacatecas, Mexico.

THEATRE ARTS / DRAMA

THEA 23 Independent Study

Transferable: CSU

Designed to afford selected students specialized opportunities for exploring areas at the independent study level. The courses may involve extensive library work, research in the community, or special projects. May be repeated until six units of credit are accrued. This course has the option of a letter grade or pass/no pass. REQUIRED: The study outline prepared by the student and the instructor must be filed with the department and the dean.

80111 Ind PB11 Abad M 1.0
80130 Ind PB11 Abad M 2.0

VOCATIONAL PREP STUDENTS: DISABILITY

AE 600 Vocational Training I

Transferable: No

Prevocational skills for adults with impaired cognitive functioning. Entry level work preparation is emphasized. Skills taught include basic work routine orientation, communication skills, job ability assessment, and self-management skills.

80007 Lab HOPEG Merrill T
06/02/08 - 08/29/08 Above class meets off-campus: HOPE Workshop, 8855 Murray Avenue, Gilroy. Open entry - open exit.
80014 Lab HOPEH Brown C
06/02/08 - 08/29/08 Above class meets off-campus: HOPE Workshop, 2300 Technology Parkway, Hollister. Open entry - open exit.

CRN Type Room Instructor Hrs. Units Days Begin-End

AE 602 Vocational Training III

Transferable: No

Practical training and on-the-job work experience for students with disabilities. This course also provides preparation for entry level employment utilizing a number of work alternatives and settings.

80016 Lab HOPEG Merrill T
06/02/08 - 08/29/08 Above class meets off-campus: HOPE Workshop, 8855 Murray Avenue, Gilroy. Open entry-open exit.
80019 Lab HOPEH Brown C
06/02/08 - 08/29/08 Above class meets off-campus: HOPE Workshop, 2300 Technology Parkway, Hollister. Open entry - open exit.
80023 Lab LI115 Lopez F
06/02/08 - 07/25/08

AE 636 Adapted Physical Education

Transferable: No

An individualized program of adapted physical education activities designed to meet the needs of students who are physically limited or disabled. The course assists in the development and appreciation of physical activity as a regular planned contribution to one's overall well-being. This course is for the non-matriculating student, is not graded and is without college credit. ADVISORY: Students must be able to document a physical disability.

80039 Lab GY100P Ellis D
06/02/08 - 07/24/08
80040 Lab LOADCS1 TBA 3.00 MTWR 1000A-1045A
06/02/08 - 07/24/08 Above class meets at Live Oak Adult Day Care, 651 West Sixth Street, Gilroy.

Beginning with the summer and fall 2008 enrollment period social security numbers will no longer be used as student identifiers. Find your new Gavilan Student ID and choose a log-on password by going to www.gavilan.edu and clicking on the Self-Service Banner icon. You will use your new ID and password to log into Self-Service Banner and register for summer and fall classes.



STAR GILROY
a STAR summer musical
- Seussical Jr.
June 23 - July 19
4 Weeks - \$525
Performances on July 18 & 19
Ages 8-16
9:00 am - 4:00 pm, M-F

Dates and plays are subject to change.



STAR SAN JUAN BAUTISTA
SHAKESPEARE - The Tempest
July 22 - August 12
Performance dates: August 11 & 12
3 weeks - \$395
Ages 10-17
9:00 am - 4:00 pm, M-F



STAR VIDEO
TV WORKSHOP
June 23 - July 11
3 Weeks - \$395
Ages 10-17
9:00 am - 4:00 pm, M-F



REGISTER NOW!
By Phone (408) 612-2057
Online www.gavilan.edu/star
Email stargav@gavilan.edu

Marilyn Abad-Cardinali, Founder/Executive Director - 408-848-4764

**NO QUIZZES!
NO TESTS!
NO LETTER GRADES!
NO FEES!**

Summer Noncredit Classes

This program is open to all students and currently offers various classes of interest to the community.

Registration will take place in the Admissions & Records Office or in class on the first day of the course. Students should contact Michelle Lopez in the Noncredit Office directly with any questions or for further information at (408) 848-4859.

ALLIED HEALTH

AH 740 Tai Chi for Arthritis and Other Related Illnesses

Transferable: No

This course is designed for the maintenance of the physical and mental well-being of an older adult with arthritis and other related illnesses. Instruction will focus on the postures and movements of Tai Chi, a Chinese exercise regimen that has a slow paced movement that improves balance, coordination, breathing and builds strength and stamina. Activities are included that promote self-care and health awareness.

80143	Lab	HHH1	Faulds H	1.00	S	1045A-1145A
Above class meets off-campus: Hazel Hawkins Hospital 911 Sunset Drive, Hollister.						
80146	Lab	VPRI1	Yinger K	1.00	R	0100P-0200P
Above class meets off-campus: Valley Pines Retirement Inn 545 E. Main Avenue, Morgan Hill.						
80147	Lab	WM1	Yinger K	2.00	TR	1000A-1100A
Above class meets off-campus: Wheeler Manor 651 W. 6th Street, Gilroy.						
80265	Lab	JDA1	Frey E	1.00	R	1115A-1215P
Above class meets off-campus: Jovenes de Antano 300 West Street, Hollister.						

AH 741 Body Dynamics and Aging

Transferable: No

This course is designed for the 55+ adult student to provide awareness and knowledge of physical fitness, stress management and nutrition to personal health. Discussions will focus on nutrition, sleep disorders, depression, leisure/social activities and chronic conditions that effect the body as aging occurs.

80244	Lec	CRC1	Lee C	1.80	W	1030A-1200P
06/04/08 - 07/23/08 Above class meets off-campus: Centennial Recreation Center 171 W. Edmundson Avenue, Morgan Hill.						

All noncredit classes are open entry/exit and free of charge.

Hollister and Morgan Hill site locations

HOL	Hollister Briggs Bldg, 365 Fourth St. Hollister
MHG	Morgan Hill Community Center, 17060 Monterey Rd., Morgan Hill

AH 793 Personal and Career Development

Transferable: No

A wide variety of lectures on general themes offered to students throughout the academic year who want short-formatted content to augment their personal, academic and career development. General themes to be explored are: Communication, Interpersonal Skills, Pre-employment, Decision-Making, Financial Literacy, Career and Personal Development. This noncredit course is a combination of lecture, self-assessments and group activities.

80188	Lab	LI168	Arteaga B	16.00	MTWR	0830A-1230P
05/29/08 - 06/11/08 This class was designed for the needs of CalWORKs students.						
80208	Lab	LI168	TBA	16.00	MTWR	0100P-0500P
05/29/08 - 06/11/08 This class was designed for the needs of CalWORKs students.						
80273	Lab	LI168	Arteaga B	8.00	MTWR	0900A-0100P
07/30/08 - 08/21/08 This class was designed for the needs of CalWORKs students.						
80275	Lab	LI171	TBA	16.00	MTWR	0830A-1230P
07/30/08 - 08/21/08 This class was designed for the needs of CalWORKs students.						
80276	Lab	LI171	TBA	16.00	MTWR	0830A-1230P
08/18/08 - 08/21/08						
80277	Lab	TBA	Garcia M	8.00	MTWR	0130P-0500P
07/30/08 - 08/21/08 This class was designed for the needs of CalWORKs students.						
80278	Lab	TBA	TBA	16.00	MTWR	0130P-0500P
07/30/08 - 08/21/08 This class was designed for the needs of CalWORKs students.						

ART

ART 760 Arts and Crafts I for Older Adults

Transferable: No

A general survey of arts and crafts with an emphasis on exercises and experiments with methods and materials, including: painting, drawing, color theory, composition and rendering, batik or tie-dye, quilting or needlepoint, crocheting or knitting and block printing.

80030	Lab	WM1	Barrett S	3.00	M	0100P-0400P
Above class meets off-campus: Wheeler Manor 651 W. 6th Street, Gilroy There is a \$25 materials fee for this course.						
80047	Lab	HVME1	Gupta R	3.00	F	0930A-1230P
Above class meets off-campus: Hacienda Valley Mobile Estates 275 Burnett Avenue, Morgan Hill. There is a \$25 materials fee for this course.						

CRN Type Room Instructor Hrs. Units Days Begin-End

CRN Type Room Instructor Hrs. Units Days Begin-End

COMPUTER SCIENCE & INFORMATION SYSTEMS

CSIS 728 Windows for the Older Adult

Transferable: No

This course is designed as an introductory course for the older adults to learn Windows operations, file management and other Windows Fundamentals.

80158	Lab	CTC2	Hernandez A	2.80	T	0900A-1130A
Above class meets off-campus: Gavilan Computer Technology Center 7881 Murray Avenue Room 2, Gilroy.						
80148	Lab	HOL3	Mendez F	2.00	MW	0430P-0530P
Above class meets at the Hollister Briggs site.						

CSIS 729 Word Processing-MS Word for the Older Adult

Transferable: No

A course designed for older adults (55+) to develop word processing skills to write and edit simple documents, format text, use bullets, create tables, insert clipart and use other features of the toolbar.

80162	Lec	CTC2	Hernandez A	2.80	R	0900A-1130A
Above class meets off-campus: Gavilan Computer Technology Center 7881 Murray Avenue Room 2, Gilroy.						

ENGLISH

ENGL 756 GED Preparation

Transferable: No

This course is designed to prepare the student to pass the five General Education Development (GED) tests in Writing, Social Studies, Science, Literature and Mathematics. English grammar and usage, reading comprehension, writing, vocabulary and computational skills are emphasized. The course is designed for students who are 18 years of age or older and elect to take the High School Equivalency Examination.

80072	Lab	CTC1	Miguel B	3.00	S	0900A-1200P
Above class meets off-campus: Gavilan Computer Technology Center 7881 Murray Avenue Room 1, Gilroy.						
80071	Lab	HOL3	Miguel B	3.00	S	0100P-0400P
Above class meets at the Hollister Briggs site.						

ENGLISH AS A SECOND LANGUAGE

ESL 702A ESL Citizenship

Transferable: No

This course is designed for second language learners that want to prepare for the United States Citizenship test given by the Department of Immigration and U. S. Naturalization Services. The focus will be on communicative English skills and knowledge of American History and Government required for passing the test to become a citizen of the United States. Readings are at the high-beginning/low-intermediate ESL level and will focus on the historical period beginning in the 1600's on through to 1980.

80060	Lec	STF1	Stuker D	3.60	MR	0600P-0730P
Above class meets off-campus: St. Frances 7950 Church Street, Gilroy.						
80063	Lec	HOLREC2	Segovia M	9.00	MWF	0600P-0900P
06/02/08 - 07/11/08 Above class meets off-campus: Hollister Recreation Center, Gabilan Room 375 5th Street, Hollister.						

ESL 704A ESL for the Workplace

Transferable: No

This is part A of a content-based integrated skills course for ESL students who want to prepare for immediate entry into the job force. Students expand their language skills within the realm of the work world and specific vocational career of interest while also developing the soft skills needed in the workplace. This course is a combination of lecture, lab, and self-paced instruction.

80167	Lab	CTC1	TBA	10.00	MTWRF	0900A-1100A
Above class meets at Gavilan Computer Technology Center Room 1, 7881 Murray Ave., Gilroy.						
80264	Lab	HOL1	Segovia M	3.00	W	0215P-0515P
Above class meets at the Hollister Briggs site.						
80174	Lab	MHG5	Sosa R	2.00	M	0600P-0800P
	Lab	JS1	Sosa R	4.00	TW	0600P-0800P
Monday class meets at Morgan Hill Community Site Tuesday & Wednesday classes meet at Jasmine Square Apts. 16530 Monterey Road, Morgan Hill.						
80176	Lab	CTC1	Padilla M	6.00	TWR	0700P-0900P
Above class meets at Gavilan Computer Technology Center 7881 Murray Avenue Room 1, Gilroy.						

NEW ESL 777 ESL Lifeskills 1

Transferable: No

This is the first course in a series of survival English classes for students with very little oral or written English competency. It will give students basic vocabulary and familiarity in life skill areas such as the family, food, health, and occupations to manage in the real world. The course emphasizes oral communication and integrates listening, speaking, reading, and writing. **ADVISORY:** Placement into ESL Lifeskills by the CASAS placement test.

80251	Lec	HOL6	TBA	11.20	MWF	0600P-0730P
Above class meets at the Hollister Briggs site.						
80252	Lec	MHG11	TBA	11.20	MWF	0600P-0730P
Above class meets at Morgan Hill Community site.						

NEW ESL 779 ESL Lifeskills 3

Transferable: No

This is the third in a series of classes in survival English for students with little oral or written English competency. It will give students expanded basic vocabulary and familiarity in life skill areas such as the weather, transportation, employment, and American holidays and customs to manage in the real world. The course emphasizes oral communication and integrates listening, speaking, reading, and writing. **ADVISORY:** Placement into ESL Lifeskills by the CASAS placement test and successful completion of ESL 778.

80269	Lec	CTC3	TBA	5.40	MWF	0900A-1030A
Above class meets at Gavilan Computer Technology Center 7881 Murray Avenue Room 3, Gilroy.						

HUMANITIES

HUM 767 Film Classics

Transferable: No

This class is designed to study the facts, fantasy, history and trivia of classic and modern films. The background and history of each film and its performance will be compared and contrasted.

80268	Lab	HOLREC1	Sendejas L	2.80	F	1000A-1230P
Above class meets at Hollister Recreation Center Dunne Park Building 375 5th Street, Hollister.						
80295	Lab	TBA	TBA	2.80	TBA	TBA
08/01/2008-08/23/2008 A mandatory orientation will be held on June 16th. For details or scheduling conflicts, contact Grant Richards at grant@garlic.com. This class will meet 14 days, 10 hours per day. Location, days and hours to be arranged by the instructor.						
80057	Lab	WM1	Sendejas L	3.00	S	0430P-0730P
Above class meets at Wheeler Manor, 651 W. 6th Street, Gilroy.						

All noncredit classes are open entry/exit and free of charge.

CRN Type Room Instructor Hrs. Units Days Begin-End

LIBRARY

LIB 730 Internet Literacy for Older Adults

Transferable: No

A class for older adults to learn email techniques, how to find information on their interests, news sources, and the skill of browsing online, as well as how best to use the local public library online services, online shopping, search strategies, and interactive games.

80106 Lec HOL3 Mendez F 3.60 MW 0300P-0430P
Above class meets at the Hollister Briggs site.

LIB 731 Finding Book Treasures in Literature for Older Adults

Transferable: No

Older adults are guided in the reading of selected quality fiction and nonfiction to promote discussions of theme development, narrative techniques, social context and what makes good writing. Content varies from semester to semester and may include fiction, drama, poetry, essay, and biography. Readings selected may have particular relevance to older adults.

80216 Lec VG1 Lee C 2.00 F 0200P-0400P
Above class meets off-campus: Village Green 7610 Isabella Way, Gilroy.

LIB 732 Introduction to Online Gavilan

Transferable: No

Introduction to the online classes and student services at Gavilan College. This course will show students how to log into their online courses, find lectures, assignments and exams, take part in online class discussions, submit attachments, and view their grades. The course will also cover all the online student services available to the distant student, including counseling, library resources, records and grades, financial aid, tutoring and technical support.

80263 Online N/A Parker J
06/09/08 - 07/25/08 This online class will be delivered entirely over the Internet. Log in at www.gavilan.edu/disted to access the class any time during the term. All noncredit classes are open entry/open exit and free of charge.

LIB 733 Exploring the Web for Older Adults

Transferable: No

Designed to address the interests of older adults, students will learn about the web's rich offering in graphics, sharing digital pictures, and downloading audio files and audiobooks after paying your bills online. Students will learn online techniques to take advantage of all the latest tools, such as wikis, blogs, search techniques and great travel destinations. ADVISORY: LIB 730, Internet Literacy for Older Adults.

80065 Lec HOL3 Mendez F 3.60 MW 0130P-0300P
Above class meets at the Hollister Briggs site.

80069 Lec MHG5 Curtis G 2.00 R 0930A-1130A
Above class meets at Morgan Hill Community site.

MUSIC

MUS 763 Music Encounters

Transferable: No

A class for older adults that provides musical activities to stimulate and sustain their auditory function, discernment of sounds and manual dexterity. Students will enjoy music, new and old, by listening, singing, playing and creating music in a group setting.

80125 Lec VPRI1 Yinger K 1.00 T 0100P-0200P
Above class meets off-campus: Valley Pines Retirement Inn 545 E. Main Avenue, Morgan Hill.

CRN Type Room Instructor Hrs. Units Days Begin-End

PHYSICAL EDUCATION

PE 701 Tai Chi for Wellness

Transferable: No

This course will introduce the student to the thirty seven posture forms and movements of Tai Chi, an ancient Chinese practice that focuses on slow paced coordinated movements that improve balance, coordination, mobility and breathing. The students will also learn how to use this non-contact exercise program to reduce stress in their daily lives.

80266 Lab APE101 Yinger K 3.00 M 0530P-0630P

PE 716 Music/Movement and Health

Transferable: No

This course is designed to assist older adults in improving overall health through movement, music and relaxation techniques. Rhythmical movement will be adjusted to suit individual students mobility needs.

80128 Lab JDA1 Host M 2.00 T 1000A-1200P
Above class meets off-campus: Jovenes de Antano 300 West Street, Hollister.

80131 Lab CRC1 Mendonca B 2.00 TF 1000A-1100A
Above class meets off-campus: Centennial Recreation Center 171 W. Edmundson Avenue, Morgan Hill.

80136 Lab CRC1 Mendonca B 2.00 TF 1100A-1200P
Above class meets off-campus: Centennial Recreation Center 171 W. Edmundson Avenue, Morgan Hill.

80138 Lab GSC1 Mendonca B 1.00 W 1000A-1100A
Lab GSC1 Mendonca B 1.00 F 0130P-0230P
Above class meets off-campus: Gilroy Senior Center 7371 Hanna Street, Gilroy.

80281 Lab VPRI1 Lee C 1.80 F 1030A-1200P
Above class meets off-campus: Valley Pines Retirement Inn, 545 E. Main Avenue, Morgan Hill .

Thinking of online courses at Gavilan College?

Take LIB 732 first!

INTRODUCTION TO ONLINE GAVILAN

A FREE introduction to the world of online education, ONLINE!

Tour the classroom and all the other services available to distance learners - financial aid, library services, tutoring and counseling.



Open entry/open exit means you can jump in or out of class any time you want.

Hollister and Morgan Hill site locations

HOL Hollister Briggs Bldg, 365 Fourth St. Hollister
MHG Morgan Hill Community Center, 17060 Monterey Rd., Morgan Hill

DISTANCE LEARNING

courses at Gavilan are offered in three different ways:

Online Courses at Gavilan College

Online courses allow students who have access to a computer and modem to take college credit classes. Students need to have access to an individual email account and the World Wide Web. Students enrolled in these Internet-delivered classes will meet with their instructors and with their classmates through the Internet. The majority of coursework is done online. However, one or more on-campus meetings may be required. If this is a problem, you may contact your instructor for possible accommodations.

After enrolling, start the class by going to <http://www.gavilan.edu/disted> and clicking on your class.

It is your responsibility to log into the class by the end of the fourth day (semester-long courses) or by the third day (short-term classes). Students who have not logged into the class by the deadline will be dropped from the course.

Orientations: We strongly recommend that students take one of the live orientations to online courses offered in the Gavilan Library. Please see the library homepage at: <http://www.gavilan.edu/library/> for a schedule of orientations or you may make a personal appointment with one of the librarians by calling 408-848-4806.

We encourage you to exercise the same kind of caution in a distance learning class as you would if you were taking an on-site class. Do not share personal information about yourself; do not give a stranger or new acquaintance your home phone number or address.

10513	AH 3	PERSON/LIFE CYCLE	BEDELL	9/3-12/20
10518	AH 11	NUTRITION	AKROP	9/3-12/20
10205	ANTH 1	INTRO PHYSICAL ANTH	KLEIN	9/3-12/20
10548	ART 6	ART APPRECIATION	EDBERG	9/3-12/20
10908	ART 140	BASIC DIGITAL FILM/VIDEO	BEEDE	9/3-12/20
10519	BIO 11	NUTRITION	AKROP	9/3-12/20
10927	CSIS 5	C++ SCIENTIFIC PROG	VAN TASSEL	9/3-12/20
10598	CSIS 8	INTRO TO INTERNET	VENABLE	9/4-10/29
10606	CSIS 24	JAVA PROGRAMMING I	VAN TASSEL	9/3-12/20
10938	CSIS 42	PYTHON PROGRAMMING	HOWELL	9/3-12/20
10611	CSIS 43	C PROGRAMMING	VAN TASSEL	9/3-12/20
10612	CSIS 45	C++ PROGRAMMING I	VAN TASSEL	9/3-12/20
10930	CSIS 49	UNIX SHELL PROGRAM	VAN TASSEL	9/3-12/20
10909	CSIS 140	BASIC DIGITAL FILM/VIDEO	BEEDE	9/3-12/20
10910	DM 140	BASIC DIGITAL FILM/VIDEO	BEEDE	9/3-12/20
10055	ENGL 1A	COMPOSITION	WISDOM	9/3-12/20
10056	ENGL 1A	COMPOSITION	CHAFFIN	9/3-12/20
10064	ENGL 1A	COMPOSITION	CROOK	9/3-12/20
10065	ENGL 1A	COMPOSITION	CROOK	9/3-12/20
10077	ENGL 1B	COMPOSITION & LIT	WISDOM	9/3-12/20
10079	ENGL 1B	COMPOSITION & LIT	WARREN	9/3-12/20
10092	ENGL 1C	CRITIC REASON/WRITE	CANDELARIA	9/3-12/20
10661	GUID 1	SELF ASSESSMENT	SHARBONEAU	9/3-12/20
10673	GUID 1	SELF ASSESSMENT	SHARBONEAU	9/3-12/20
10530	HE 1	HEALTH EDUCATION	QUATRE	9/3-12/20
10532	HE 2	HUMAN SEXUALITY	QUATRE	9/3-12/20
10238	HIST 2	U.S. HISTORY	GUARDINO	9/3-12/20
10555	HUM 4	INTRO AMER CINEMA	RICHARDS	9/3-12/20
10306	LIB 732	INTRO TO ONLINE GAVILAN	PARKER	8/18-12/20
10970	MATH 5	INTRO STATISTICS	HAUSSERMANN	9/3-12/20
10258	POLS 1	INTRO AMERICAN GOVERNMENT	TURETZKY	9/312/20
10268	POLS 1	INTRO AMERICAN GOVERNMENT	TURETZKY	9/312/20
10289	POLS 4	INTRO/INTL RELATION	TURETZKY	9/312/20
10853	PSCI 2	INTRO METEOROLOGY	VANTUYL	9/312/20
10973	PSYC 3	CHILD GROWTH/DEV	BUMGARNER	9/3-12/20
10700	PSYC 5	SELF ASSESSMENT	SHARBONEAU	9/312/20
10678	PSYC 5	SELF ASSESSMENT	SHARBONEAU	9/3-12/20
10986	RE 165	LEGAL ASPECTS RE	BANKS	9/3-12/20
10742	SPAN 12A	SPAN/SPAN SPEAKERS	TBA	9/312/20

LATE START "CYBERSESSION"

10038	CSIS 3	RESEARCH SKILLS	MEADER	10/14-12/8
10509	CSIS 6	WEBPAGE AUTHORING I	VENABLE	9/29-11/23
10470	CSIS 6	WEBPAGE AUTHORING I	HOWELL	10/20-12/14
10599	CSIS 8	INTRO TO INTERNET	VENABLE	10/29-12/21
10473	DM 6	WEBPAGE AUTHORING I	HOWELL	10/20-12/14
10508	DM 6	WEBPAGE AUTHORING I	VENABLE	9/29-11/23
10037	LIB 3	RESEARCH SKILLS	MEADER	10/14-12/8
10597	LIB 6	WEBPAGE AUTHORING I	VENABLE	9/29-11/23
10596	LIB 6	WEBPAGE AUTHORING I	HOWELL	10/20-12/14
10750	THEA 3	EL TEATRO CAMPESINO	GONZALEZ	10/15-12/20
10760	THEA 20	INTRO SCRIPTWRITING	GONZALEZ	10/15-12/20



Online



Hybrid - online and classroom



Telecourses

Hybrid Courses

Hybrid courses are a combination of traditional meetings and online meetings. Typically you will meet in a regular classroom once a week, and meet online once a week. You'll get the convenience of online courses, but have the advantage of meeting with your instructor and classmates too. See individual webpages for these classes for details.

SECT	COURSE	DESCRIPTION	INSTRUCTOR	UNITS	BEGIN/END	FACE-TO-FACE MEETINGS			+ ONLINE
10308	ACCT 20	FINANCIAL ACCOUNTING <small>Class meets 9/3, 9/10, 10/8, 10/15, 11/19, 12/10 and 12/17</small>	WOLOWITZ J	4.0	09/03-12/20	BU118	W	0600P-0905P	+ ONLINE
10876	BIO 15	SURVEY/HUMAN ANAT/PHYS	JOHNSON B	5.0	09/03-12/20	LS103	W	0400P-0705P	+ ONLINE
10448	CSIS 2	COMP IN BUS/MS OFFICE	VENABLE E	4.0	09/03-12/20	BU11	TU	0945A-1105A	+ ONLINE
10452	CSIS 2	COMP IN BUS/MS OFFICE	VENABLE E	4.0	09/03-12/20	BU11	F	0945A-1105A	+ ONLINE
10064	ENGL 1A	COMPOSITION	CROOK E	3.0	09/03-12/20	PB14	T	1120A-1240P	+ ONLINE
10065	ENGL 1A	COMPOSITION	CROOK E	3.0	09/03-12/20	PB14	R	1120A-1240P	+ ONLINE
10750	THEA 3	EL TEATRO CAMPESINO	GONZALEZ R	3.0	09/03-12/20	See online syllabus for meeting details			+ ONLINE

Thinking of online courses at Gavilan College?

Take LIB 732 first!

INTRODUCTION TO ONLINE GAVILAN

A FREE introduction to the world of online education, ONLINE!

Tour the classroom and all the other services available to distance learners - financial aid, library services, tutoring and counseling.

Open entry/open exit means you can jump in or out of class any time you want.

For details see page 114.

San Jose State University Telecourses at Gavilan College - Fall 2008

San Jose State University classes begin August 25 and last day of instruction is December 10, 2008.

Holidays: September 1(Labor Day), November 11 (Veteran's Day) and November 27 & 28 (Thanksgiving)

There is a \$25 site fee per class to be paid to Gavilan College.

Classes meet in PB11N.

To register for television classes or for more information on dates, times and admission fees, contact: Gavilan College 408-848-4719 or SJSU 408-924-3624.

COURSE#	DAY	TITLE	TIME
EDCO 266	M	Education & Career Planning	4-6:45PM
EDCO 215	M	Introduction To Counseling & Guidance	7-9:45PM
EDCO 282	T	Education Assessment	4-6:45PM
EDCO 280	T	Practicum In Multi Counseling	7-9:45PM
EDCO 286	W	Theory of Org Change	7-9:45PM
EDCO 248	R	Dynamic of Behavior & Development	4-6:45PM
EDCO 221	R	Research Seminar in Education	7-9:45PM

Gavilan College at the Morgan Hill Community Center

17060 Monterey Rd.
Morgan Hill, CA 95037
(408) 782-2873

Lorraine Welk, Instructional Site Director
Irma Banuelos, Program Service Specialist

Site Office Hours - See inside front cover.

**save gas!
save time!
save energy!**

**Take 12 units of transferable
General Education classes during
the day in Morgan Hill!**

<u>CRN</u>	<u>COURSE</u>	<u>DESCRIPTION</u>	<u>TIME</u>	<u>UNITS</u>	<u>ROOM</u>
<u>Monday/Wednesday</u>					
10170	ANTH 9	CULTURAL / CHLDHOOD	11:20A-12:40P	3	MHG4
10154	CD 2	EARLY CHILD DEVELOP	9:45A-11:05A	3	MHG4
10168	CD 7	CULTURAL / CHLDHOOD	11:20A-12:40P	3	MHG4
10099	ENGL 1C	CRITIC REASON/WRITE	11:20A-12:40P	3	MHG11
10157	PSYC 2	EARLY CHILD DEVELOP	9:45A-11:05A	3	MHG4
10169	PSYC 7	CULTURAL / CHLDHOOD	11:20A-12:40P	3	MHG4
10342	SOC 1A	INTRO TO SOCIOLOGY	9:45A-11:05A	3	MHG10
<u>Tuesday/Thursday</u>					
10043	ENGL 1A	COMPOSITION	8:10A-9:30A	3	MHG3
10374	ENGL 250	PRACTICAL WRITING	9:45A-11:05A	3	MHG11
Choose a lab:					
10376	ENGL 250 Lab R		11:15A-12:05P	N/A	MHG11
10375	ENGL 250 Lab T		11:15A-12:05P	N/A	MHG11
10284	POLS 1	INTRO AMERICAN GOV	11:20A-12:40P	3	MHG4
<u>MTuWTh</u>					
10826	MATH 233	INTERMED ALGEBRA	12:50P-1:55P	5	MHG10

Expanded Counseling Services

available in Morgan Hill
By appointment only. Photo ID
and Gavilan Student ID are required to
obtain counseling services.

Call (408) 782-2873 to
schedule an appointment.

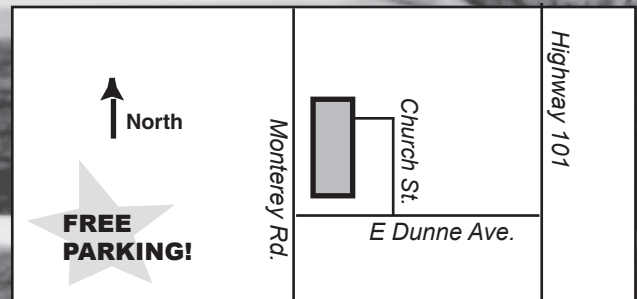

We are pleased to provide the following services for your convenience at the Morgan Hill Community Center satellite site:

Admissions	Accept applications for admission Sell catalogs and distribute class schedules Purchase parking passes	Counseling	Daytime and evening academic planning and personal counseling services available
Registration and Records	Class registration Add/drops Assessment test results Purchase Student Body IDs Unofficial grade print-outs Dispense forms: Transcript Requests, Repeated Course Requests, Prerequisite Challenge Forms, etc.	Financial Aid	Assistance with BOG Fee Waiver forms Assistance with financial aid information
Orientations	(online)	Bookstore	Buy textbooks for your Morgan Hill classes the first week of fall semester, Order textbooks online at efollet.com, Purchase scantrons and bluebooks
Placement/ Assessment	check website for times and locations	Health Services	First aid supplies and health education materials
EOPS/CalWORKs/CARE	1st & 3rd Tuesdays, 5:30-7:00 pm	Library	Provides research assistance via email and phone Search e-books and databases, and much more
DRC	Every third Wednesday, 5:30 - 8 pm, by appointment Call (408) 848-4767.	Career/Transfer Computer Access	College catalogs, EUREKA career assessment Student drop-in lab available to all students registered at Gavilan College. Open during office hours

Services for veterans and international students available at the main campus. All other services, including CARE, MESA, TRIO, Tutoring, etc. are available at the Gilroy main campus. Call 408-848-4800. Check catalog or website for complete listings - www.gavilan.edu

CRN	COURSE	DESCRIPTION	UNITS	BEGIN-END	DAY	TIMES	ROOM
10350	ACCT 105	PAYROLL ACCOUNTING	6:00P-9:05P		R	9/25-12/11	MHG4
10354	ACCT 111	INTRO INCOME TAX	6:00P-9:05P		T	9/3-12/20	MHG4
10359	ACCT 120	COMPUTERIZED ACCTNG	6:00P-9:05P		M	9/3-12/20	MHG5
10365	AE 600	VOC TRAIN I	9:45A-1:50P		M	9/3-12/20	MHG3
10377	AE 603	VOC TRAIN IV	9:45A-12:50P		F	9/3-12/20	MHG8
10256	AJ 12	CRIMINAL PROCEDURE	2:50P-5:55P		T	9/3-12/20	MHG12
10286	AJ 18	CMUN/HUMAN RELATION	6:30P-9:35P		W	9/3-12/20	MHG10
10288	AJ 19	INTRO/INVESTIGATION	6:30P-9:35P		M	9/3-12/20	MHG3
10295	AJ 21	NARC/DRUG ABUSE	3:00P-6:05P		R	9/3-12/20	MHG3
10296	AJ 32	CRIME & DELINQUENCY	6:30P-9:35P		T	9/3-12/20	MHG11
10299	AJ 173	FUND OF PROBA/PAROL	6:00P-9:05P		R	9/3-12/20	MHG10
10170	ANTH 9	CULTURAL / CHLDHOOD	11:20A-12:40P		MW	9/3-12/20	MHG4
10541	ART 1B	ART HISTORY	6:00P-9:05P		R	9/3-12/20	MHG12
10614	ART 74	ADVANCED PHOTOSHOP	6:30P-9:35P		R	9/3-12/20	MHG5
10624	ART 75	PHOTOSHOP I	6:30P-9:35P		T	9/3-12/20	MHG5
10662	ART 85	WEB DESIGN I: DREAM	6:00P-9:05P		W	9/24-12/10	MHG8
10789	ASTR 1	INTRO GEN ASTRONOMY	6:00P-9:05P		T	9/3-12/20	MHG13
10415	BOT 180	MEDICAL TERM/OFFICE	3:00P-5:55P		R	9/3-12/20	MHG4
10431	BUS 1	FUND OF BUSINESS	6:00P-9:05P		W	9/3-12/20	MHG3
10152	CD 1	PRIN/PHIL EC EDUC	6:00P-9:05P		T	9/3-12/20	MHG3
10154	CD 2	EARLY CHILD DEVELOP	9:45A-11:05A		MW	9/3-12/20	MHG4
10168	CD 7	CULTURAL / CHLDHOOD	11:20A-12:40P		MW	9/3-12/20	MHG4
10975	CD 8A	AMER ED CHG WORLD	6:00P-9:05P		R	9/3-12/20	MHG11
10179	CD 20	CHILDREN'S LAN/LIT	6:00P-9:05P		W	9/3-12/20	MHG4
10605	CMUN 1A	INTRO PUBLIC SPEAK	6:00P-9:05P		M	9/3-12/20	MHG12
10631	CMUN 10	SMALL GROUP CMUN	6:00P-9:05P		W	9/3-12/20	MHG12
10609	CSIS 24	JAVA PROGRAMMING I	6:00P-9:50P		M	9/3-12/20	MHG8
10929	CSIS 49	UNIX SHELL PROGRAM	6:00P-9:50P		T	9/3-12/20	MHG8
10931	CSIS 54	PERL PROGRAMMING	6:00P-9:05P		R	9/3-12/20	MHG8
10932	CSIS 54L	PERL PROGRAMMING LB	9:05P-10:00P		R	9/3-12/20	MHG8
10615	CSIS 74	ADVANCED PHOTOSHOP	6:30P-9:35P		R	9/3-12/20	MHG5
10629	CSIS 75	PHOTOSHOP I	6:30P-9:35P		T	9/3-12/20	MHG5
10665	CSIS 85	WEB DESIGN I: DREAM	6:00P-9:05P		W	9/24-12/10	MHG8
10362	CSIS 120	COMPUTER ACCOUNTING	6:00P-9:05P		M	9/3-12/20	MHG5
10882	CSIS 122	COMPUTER KEYBOARD	8:30A-12:20P		S	9/6-12/20	MHG8
10881	CSIS 122	COMPUTER KEYBOARD	8:30A-10:20A		S	9/6-12/20	MHG8
10898	CSIS 124	WINDOWS FUNDAMENTAL	8:30A-12:20P		S	9/13-10/11	MHG8
10904	CSIS 126	WORD PROCESS-MS WRD	9:00A-12:05P		R	9/18-12/11	MHG8
10901	CSIS 126	WORD PROCESS-MS WRD	8:30A-12:20P		S	10/18-12/20	MHG8
10616	DM 74	ADVANCED PHOTOSHOP	6:30P-9:35P		R	9/3-12/20	MHG5
10630	DM 75	PHOTOSHOP I	6:30P-9:35P		T	9/3-12/20	MHG5
10670	DM 85	WEB DESIGN I: DREAM	6:00P-9:05P		W	9/24-12/10	MHG8
10057	ENGL 1A	COMPOSITION	6:00P-9:05P		T	9/3-12/20	MHG10
10043	ENGL 1A	COMPOSITION	8:10A-9:30A		TR	9/3-2/20	MHG3
10099	ENGL 1C	CRITIC REASON/WRITE	11:20A-12:40P		MW	9/3-12/20	MHG11
10374	ENGL 250	PRACTICAL WRITING	9:45A-11:05A		TR	9/3-12/20	MHG11
10376	ENGL 250	PRACTICAL WRITING	11:15A-12:05P		R	9/3-12/20	MHG11
10375	ENGL 250	PRACTICAL WRITING	11:15A-12:05P		T	9/3-12/20	MHG11
10450	ENGL 250	PRACTICAL WRITING	8:30P-9:20P		T	9/3-12/20	MHG13
10449	ENGL 250	PRACTICAL WRITING	7:00P-8:20P		TR	9/3-12/20	MHG13
10451	ENGL 250	PRACTICAL WRITING	8:30P-9:20P		R	9/3-12/20	MHG13
10457	ENGL 260	PREP/COLLEGE READNG	5:30P-6:50P		TR	9/3-12/20	MHG13
10434	ESL 704A*	ESL FOR THE WORKPLACE	6:00P-8:00P		W	9/3-12/20	MHG5
11004	ESL 777*	ESL LIFESKILLS 1	10:00A-11:30A		MWF	9/3-12/20	MHG13
11008	ESL 778*	ESL LIFESKILLS 2	9:30A-11:30A		TR	9/3-12/20	MHG13
10216	GEOG 1	PHYSICAL GEOG L/L	9:45A-12:10P		TR	9/3-12/20	MHG12
10264	LIB 733*	EXPLORING THE WEB	9:30A-11:30A		R	9/3-12/20	MHG5
10962	LIB 734*	LEGAL RESOURCES	2:30P-5:30P		W	10/1-11/5	MHG12
10805	MATH 5	INTRO STATISTICS	6:00P-8:05P		MW	9/3-12/20	MHG13
10808	MATH 12	MATH FOR TEACHERS	6:00P-9:05P		T	9/3-12/20	MHG12
10810	MATH 205	ELEM ALGEBRA	12:50P-1:55P		MTWR	9/3-12/20	MHG13
10818	MATH 205	ELEM ALGEBRA	6:00P-8:25P		TR	9/3-12/20	MHG13
10826	MATH 233	INTERMED ALGEBRA	12:50P-1:55P		MTWR	9/3-12/20	MHG10
10090	PE 62	YOGA	5:00P-6:20P		MW	9/3-12/20	MHG10
10090	PE 62	YOGA	5:00P-6:20P		MW	9/3-12/20	MHG11
10284	POLS 1	INTRO AMERICAN GOVERNMENT	11:20A-12:40P		TR	9/3-12/20	MHG4
10157	PSYC 2	EARLY CHILD DEVELOP	9:45A-11:05A		MW	9/3-12/20	MHG4
10169	PSYC 7	CULTURAL / CHLDHOOD	11:20A-12:40P		MW	9/3-12/20	MHG4
10342	SOC 1A	INTRO TO SOCIOLOGY	9:45A-11:05A		MW	9/3-12/20	MHG10
10741	SPAN 8B	CONVER SPANISH	6:35P-9:35P		M	9/3-12/20	MHG11

* Noncredit classes. For more information about Noncredit classes in Morgan Hill see page 111-114.

Gavilan College offers courses that meet in Morgan Hill and Hollister, on the weekend and start late in the semester. See course listings starting on page 26 (summer) and page 52 (fall) and consult a counselor for guidance. Students may register online or at any of our three sites.

MORGAN HILL CLASSES

(San Benito County)

Briggs Building
365 Fourth St.
Hollister, CA 95023
(831) 636-3783

Judy Rodriguez, Instructional Site Director
Natalie Juarez, Program Service Specialist
Site Office Hours: See inside front cover.

**save gas!
save time!
save energy!**

**Take 12 units of transferable
General Education classes during
the day in Hollister!**

GAVILAN COLLEGE

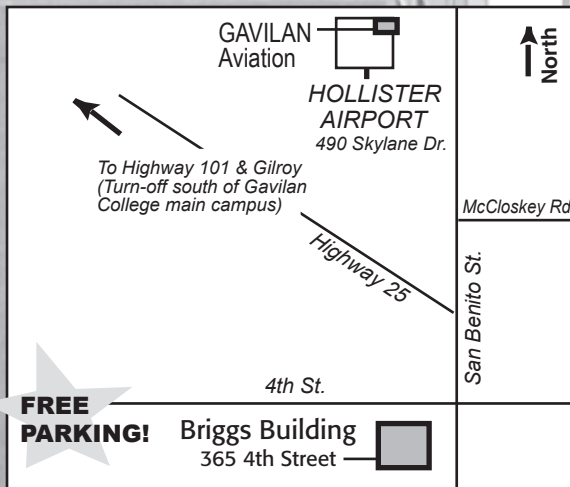

CRN COURSE DESCRIPTION TIME UNITS ROOM

Monday/Wednesday

10620	CMUN 5	FUND CMUN STUDIES	8:10A-9:30A	3	HOL2
10628	CMUN 10	SMALL GROUP CMUN	9:45A-11:05A	3	HOL2
10050	ENGL 1A	COMPOSITION	2:30P-3:50P	3	HOL6
10324	PSYC 1A	INTRO TO PSYCHOLOGY	11:20A-12:40P	3	HOL4

Tuesday/Thursday

10382	ENGL 250	PRACTICAL WRITING	9:45A-11:05A	3	HOL6/3
Choose a lab to go with the above ENGL 250:					
10383	ENGL 250 Lab T		8:45A-9:35A	N/A	HOL2
10386	ENGL 250 Lab R		8:45A-9:35A	N/A	HOL2
10222	HIST 1	US HISTORY	11:20A-12:40P	3	HOL1
10240	HIST 2	U.S. HISTORY	9:45A-11:05A	3	HOL2
10568	HIST 21	ANCIENT AMERICAS	2:30P-3:50P	3	HOL5
10726	PHIL 3A	ETHICS	9:45A-11:05A	3	HOL1
10728	PHIL 4	CRITICAL THINK/WRIT	8:10A-9:30A	3	HOL1
10567	ART 21	ANCIENT AMERICAS	2:30P-3:50P	3	HOL5
10091	ENGL 1B	COMPOSITION & LIT	11:20A-12:40P	3	HOL4

Mon/Tues/Wed/Thurs

10813	MATH 205	ELEM ALGEBRA	12:50P-1:55P	5	HOL5
10828	MATH 233	INTERMED ALGEBRA	12:50P-1:55P	5	HOL4
10733	SPAN 1A	ELEMENTARY SPANISH	9:45A-10:50A	5	HOL5
10738	SPAN 1B	ELEMENTARY SPANISH	8:30A-9:35A	5	HOL5

Fri

10951	ENGL 260	PREP/COLLEGE READNG	9:00A-12:05P	3	HOL1
-------	----------	---------------------	--------------	---	------

We are pleased to provide the following services for your convenience at the Hollister Briggs Building satellite site:

Admissions Accept applications for admission
Sell catalogs and distribute class schedules
Purchase parking passes
Purchase Student Body IDs

Registration and Records Class registration
Add/drops
Assessment test results
Unofficial grade print-outs
Dispense forms: Transcript Requests, Repeated Course Requests, Progress Reports, High School Contracts, etc.

Orientations online
Placement Assessment check website for times and locations

Counseling Daytime and evening academic planning and personal counseling services available

Financial Aid Assistance with BOG Fee Waiver forms
Assistance with financial aid information

Bookstore Buy textbooks for your Hollister classes the first week of fall semester, Order textbooks online at efollet.com, Purchase scantrons

Library Provides research assistance via email and phone
Search e-books and databases, and much more

Career/Transfer EOPS/CalWORKs/CARE College catalogs, EUREKA career assessment
5:30-6:30 every Wednesday

DRC Every second Thursday, 5:30 - 8:00 pm, by appointment. Call (408) 848-4767

Computer Access Student drop-in lab available to all students registered at Gavilan College. Open during office hours

Health Services First aid supplies and health education materials

Services for veterans and international students available at the main campus. All other services, including DRC, CARE, MESA, TRIO and Tutoring are available at the Gilroy main campus. Call 408-848-4800. Check catalog or website for complete listings - www.gavilan.edu

Fall 2008 Schedule

CRN	COURSE	DESCRIPTION	TIMES	DAY	BEGIN-END	ROOM
10539	AMT 123	INDEPENDENT STUDY			8/13-12/19	AV102
10540	AMT 123	INDEPENDENT STUDY			8/13-12/19	AV102
10534	AMT 100	GEN AIRCRAFT TECH	8:00A-10:30A	MTWRF	8/13-12/19	AV102
10537	AMT 120	POWERPLANT TECH	8:30A-3:00P	TWRF	8/13-12/19	AV102
10557	AMT 110	AIRFRAME MAINT	10:30A-3:30P	WRF	8/13-12/19	AV102
10557	AMT 110	AIRFRAME MAINT	10:30A-3:30P	MT	8/13-12/19	AV102
10364	ACCT 120	COMPUTERIZED ACCTNG	5:30P-8:35P	F	9/3-12/20	HOL3
10870	ACCT 121	SPREADSHEET-MS EXCL	6:00P-9:05P	T	9/23-12/9	HOL3
10209	ANTH 1	INTRO PHYSICAL ANTH	6:00P-9:05P	M	9/3-12/20	HOL2
10567	ART 21	ANCIENT AMERICAS	2:30P-3:50P	TR	9/3-12/20	HOL5
10190	ART 25A	ART METHODS	4:00P-8:05P	F	9/3-12/20	HOL1
10192	ART 25B	CONCEPT ART METHODS	4:00P-8:05P	F	9/3-12/20	HOL1
10790	ASTR 1	INTRO GEN ASTRONOMY	6:00P-9:05P	M	9/3-12/20	HOL1
10413	BOT 180	MEDICAL TERM/OFFICE	9:45A-12:40P	M	9/3-12/20	HOL1
10429	BUS 1	FUND OF BUSINESS	12:50P-2:10P	TR	9/3-12/20	HOL1
10435	BUS 14	PERSONAL FINANCE	8:00A-11:05A	S	9/3-12/20	HOL2
10159	CD 2	EARLY CHILD DEVELOP	6:00P-9:05P	W	9/3-12/20	HOL2
10189	CD25A	ART METHODS	4:00P-8:05P	F	9/3-12/20	HOL1
10191	CD 25B	CONCEPT ART METHODS	4:00P-8:05P	F	9/3-12/20	HOL1
10607	CMUN 1A	INTRO PUBLIC SPEAK	6:00P-9:05P	R	9/3-12/20	HOL2
10620	CMUN 5	FUND CMUN STUDIES	8:10A-9:30A	MW	9/3-12/20	HOL2
10628	CMUN 10	SMALL GROUP CMUN	9:45A-11:05A	MW	9/3-12/20	HOL2
10902	CMUN 129	PRESENTATN GRAPHICS	11:20A-1:25P	MW	11/24-12/8	HOL3
10444	CSIS 1	COMPUTER LITERACY	11:20A-1:25P	MW	9/10-11/3	HOL3
10446	CSIS 1	COMPUTER LITERACY	6:00P-9:05P	R	9/18-12/11	HOL3
10409	CSIS 120	COMPUTER ACCOUNTING	5:30P-8:35P	F	9/3-12/20	HOL3
10871	CSIS 121	SPREADSHEET-MS EXCL	6:00P-9:05P	T	9/23-12/9	HOL3
10891	CSIS 122	COMPUTER KEYBOARD	6:30P-8:20P	W	9/3-12/20	HOL3
10874	CSIS 122	COMPUTER KEYBOARD	9:45A-11:05A	MW	9/3-12/20	HOL3
10878	CSIS 122	COMPUTER KEYBOARD	11:20A-1:25P	MW	9/3-12/20	HOL3
10875	CSIS 122	COMPUTER KEYBOARD	9:45A-12:40P	MW	9/3-12/20	HOL3
10877	CSIS 122	COMPUTER KEYBOARD	11:20A-12:40P	MW	9/3-12/20	HOL3
10892	CSIS 122	COMPUTER KEYBOARD	6:30P-9:35P	W	9/3-12/20	HOL3
10894	CSIS 124	WINDOWS FUNDAMENTAL	9:00A-11:05A	MW	9/8-10/8	HOL3
10899	CSIS 126	WORD PROCESS-MS WRD	6:00P-9:05P	M	9/15-12/15	HOL3
10903	CSIS 129	PRESENTATN GRAPHICS	11:20A-1:25P	MW	11/24-12/8	HOL3
10994	CSIS 728	WINDOWS FOR THE OA	4:30P-5:30P	MW	9/3-12/20	HOL3
10933	ECON 10	FUND OF ECONOMICS	2:15P-5:20P	T	9/3-12/20	HOL1
10438	ECON 14	PERSONAL FINANCE	8:00A-11:05A	S	9/3-12/20	HOL2
10060	ENGL 1A	COMPOSITION	6:00P-9:05P	W	9/3-12/20	HOL1
10050	ENGL 1A	COMPOSITION	2:30P-3:50P	MW	9/3-12/20	HOL6
10091	ENGL 1B	COMPOSITION & LIT	11:20A-12:40P	TR	9/3-12/20	HOL4
10383	ENGL 250	PRACTICAL WRITING	8:45A-9:35A	T	9/3-12/20	HOL2
10386	ENGL 250	PRACTICAL WRITING	8:45A-9:35A	R	9/3-12/20	HOL2
10382	ENGL 250	PRACTICAL WRITING	9:45A-11:05A	R	9/3-12/20	HOL3
10382	ENGL 250	PRACTICAL WRITING	9:45A-11:05A	T	9/3-12/20	HOL6
10951	ENGL 260	PREP/COLLEGE READNG	9:00A-12:05P	F	9/3-12/20	HOL1
10472	ENGL 420	READING IMPROVE	5:30P-7:35P	TR	9/3-12/20	HOL6
10494	ENGL 440	BASIC WRITING	9:10P-10:00P	T	9/3-12/20	HOL6
10495	ENGL 440	BASIC WRITING	9:10P-10:00P	R	9/3-12/20	HOL6
10493	ENGL 440	BASIC WRITING	7:45P-9:05P	TR	9/3-12/20	HOL6
10279	ENGL 756*	GED PREPARATION	1:00P-4:00P	S	9/3-12/20	HOL3
10992	ESL 501	SURVIVAL ESL I	8:10A-10:40A	MWF	9/3-12/20	HOL6
10992	ESL 501	SURVIVAL ESL I	8:10A-9:30A	T	9/3-12/20	HOL6
10786	ESL 502	SURVIVAL ESL II	9:10A-11:05A	MTWRF	9/3-12/20	HOL4
10787	ESL 503	SURVIVAL ESL III	11:15A-1:10P	MTWRF	9/3-12/20	HOL2
10964	ESL 780*	ESL LIFESKILLS 4	6:00P-7:30P	MWF	9/3-12/20	HOL6
10965	ESL 780*	ESL LIFESKILLS 4	7:45P-9:15P	MWF	9/3-12/20	HOL6
10967	ESL 781*	ESL LIFESKILLS 5	7:45P-9:15P	MWF	9/3-12/20	HOL4
10966	ESL 781*	ESL LIFESKILLS 5	6:00P-7:30P	MWF	9/3-12/20	HOL4
10011	GUID 1	SELF ASSES/CAREER DEV	2:30P-4:35P	W	9/3-12/20	HOL1
10531	HE 1	HEALTH EDUCATION	6:00P-9:05P	W	9/3-12/20	HOL5
10222	HIST 1	US HISTORY	11:20A-12:40P	TR	9/3-12/20	HOL1
10240	HIST 2	U.S. HISTORY	9:45A-11:05A	TR	9/3-12/20	HOL2
10237	HIST 2	U.S. HISTORY	6:00P-9:05P	T	9/3-12/20	HOL2
10568	HIST 21	ANCIENT AMERICAS	2:30P-3:50P	TR	9/3-12/20	HOL5
10302	LIB 730*	INTERNET LITERACY	3:00P-4:00P	MW	9/3-12/20	HOL3
10266	LIB 733*	EXPLORING THE WEB	1:30P-3:00P	MW	9/3-12/20	HOL3
10817	MATH 205	ELEM ALGEBRA	6:00P-8:25P	TR	9/3-12/20	HOL4
10813	MATH 205	ELEM ALGEBRA	12:50P-1:55P	MTWR	9/3-12/20	HOL5
10828	MATH 233	INTERMED ALGEBRA	12:50P-1:55P	MTWR	9/3-12/20	HOL4
10726	PHIL 3A	ETHICS	9:45A-11:05A	TR	9/3-12/20	HOL1
10728	PHIL 4	CRITICAL THINK/WRIT	8:10A-9:30A	TR	9/3-12/20	HOL1
10324	PSYC 1A	INTRO TO PSYCHOLOGY	11:20A-12:40P	MW	9/3-12/20	HOL4
10327	PSYC 1A	INTRO TO PSYCHOLOGY	6:00P-9:05P	R	9/3-12/20	HOL5
10161	PSYC 2	EARLY CHILD DEVELOP	6:00P-9:05P	W	9/3-12/20	HOL2
10015	PSYC 5	SELF ASSES/CAREER DEV	2:30P-4:35P	W	9/3-12/20	HOL1
10343	SOC 1A	INTRO TO SOCIOLOGY	6:00P-9:05P	R	9/3-12/20	HOL1
10733	SPAN 1A	ELEMENTARY SPANISH	9:45A-10:50A	MTWR	9/3-12/20	HOL5
10738	SPAN 1B	ELEMENTARY SPANISH	8:30A-9:35A	MTWR	9/3-12/20	HOL5
10740	SPAN 8A	CONVER SPANISH	6:00P-9:05P	M	9/3-12/20	HOL5

* Noncredit classes. For more information about Noncredit classes in Morgan Hill see page 111-114.

** Meets at Gavilan College Aviation Department, 490 Skylane Drive, Hollister Airport, Hollister. Aviation classes begin August 13, 2008.

Gavilan College
offers courses
that meet in
Morgan Hill and
Hollister, on the
weekend and start
late in the semester.
See course listings
starting on page 26
(summer) and page
52 (fall) and consult
a counselor for
guidance. Students
may register
online or at any of
our three sites.

HOLLISTER CLASSES



FALL 2008 CLASSES

For listings of:

Courses with additional fees page 7
 First Year Experience page 82-83
 Hollister classes pages 50-51
 Indiana University page 123
 Morgan Hill classes pages 48-49
 Noncredit classes pages 111-114
 Online/Hybrid courses pages 46-47
 ROP classes pages 115-116
 Telecourses (San Jose State University) page 47
 Transfer Institute pages 16, 122
 Final Exams page 117

Beginning with the summer and fall 2008 enrollment period social security numbers will no longer be used as student identifiers. Find your new Gavilan Student ID and choose a log-on PIN by going to www.gavilan.edu and clicking on the Self-Service Banner icon. You will use your new ID and PIN to log into Self-Service Banner and register for summer and fall classes.

Campus under construction ROOM NUMBERS MAY CHANGE!

Check room numbers online before your first class.

CRN Type Room Instructor Hrs. Units Days Begin-End

ACCOUNTING

ACCT 20 Financial Accounting

Transferable: CSU, UC; CAN:BUS2, BUS SEQ A

An introduction to accounting principles and concepts. The course includes the application of accounting theory to accumulate and summarize financial data. This course has the option of a letter grade or pass/no pass. ADVISORY: Eligible for English 250, English 260 and Mathematics 233. Microsoft Excel or other computer spreadsheet knowledge.

10303	Lec	BU118	Wolowitz J	4.60	4.0	TR	0900A-1105A
10307	Lec	BU118	Wolowitz J	3.30	4.0	W	0235P-0540P
10308	Lec	BU118	Wolowitz J	3.30	4.0	W	0600P-0905P
	Lec	ONLINE	Wolowitz J				



This is a hybrid class that meets on specific dates: 9/3, 9/10, 10/8, 10/15, 11/19, 12/10 and 12/17.

ACCT 21 Managerial Accounting

Transferable: CSU, UC; CAN:BUS4, BUS SEQ A

This course covers internal uses of accounting information for managerial decision making. Includes coverage of managerial control methods, cost accounting, cost-volume-profit relationships, variable costing, budgeting, and other related topics. This course has the option of a letter grade or pass/no pass. ADVISORY: Accounting 20. Microsoft Excel or other computer spreadsheet knowledge.

10309	Lec	BU118	Wolowitz J	4.60	4.0	TR	1250P-0255P
-------	-----	-------	------------	------	-----	----	-------------

ACCT 23 Independent Study

Transferable: CSU

Designed to afford selected students specialized opportunities for exploring areas at the independent study level. The courses may involve extensive library work, research in the community, or special projects. May be repeated until six units of credit are accrued. This course has the option of a letter grade or pass/no pass. REQUIRED: The study outline prepared by the student and the instructor must be filed with the department and the dean.

10310	Ind	BU123	Wolowitz J		1.0		
10312	Ind	BU123	Wolowitz J		2.0		

Classroom Locations: Refer to "How to Use This Schedule" on page 6.

CRN	Type	Room	Instructor	Hrs.	Units	Days	Begin-End
-----	------	------	------------	------	-------	------	-----------

ACCT 103 General Office Accounting

Transferable: CSU

This course is designed to prepare students for entry-level office accounting positions. Emphasis is on practical accounting applications. This course has the option of a letter grade or pass/no pass. ADVISORY: Eligible for Mathematics 205.

10345	L/L	BU118	College A	3.30	2.0	F	0900A-1205P
ROP class.							

10347	L/L	BU118	Brown R	3.30	2.0	R	0600P-0905P
-------	-----	-------	---------	------	-----	---	-------------

ACCT 105 Payroll Accounting

Transferable: CSU

An introduction to the calculating, journalizing, paying and reporting of employee earnings, employee withholding and employer payroll tax expenses. The course emphasizes procedures which conform to federal and state legal requirements. This course has the option of a letter grade or pass/no pass. ADVISORY: Eligible for Mathematics 205, completion of Accounting 101.

10350	Lec	MHG4	Barta M	3.30	2.0	R	0600P-0905P
09/25/08 - 12/11/08 Class meets at Morgan Hill Community site. ROP class.							

ACCT 111 Introduction to Income Tax

Transferable: CSU

A study of theory, philosophy, and principles of income tax law and procedures for computing the tax liability. It includes practice in solving typical individual tax problems. This course has the option of a letter grade or pass/no pass. ADVISORY: Eligible for English 250, English 260 and Mathematics 205.

10354	Lec	MHG4	Barta M	3.30	3.0	T	0600P-0905P
Class meets at Morgan Hill Community site. ROP class.							

ACCT 120 Computerized Accounting - QuickBooks

Transferable: CSU

An introduction to computer-assisted accounting. Hands-on use of a microcomputer menu-driven accounting package to do general ledger, sales journal, cash receipts journal, cash payments journal, purchases journal, payroll, receivables, payables and related financial reports. This course has the option of a letter grade or pass/no pass. Repeatable whenever a new software package is adopted. This course is also listed as CSIS 120. ADVISORY: CSIS 1 or CSIS 2 or the equivalent computer experience. ACCT 20 or ACCT 101 or ACCT 103 or ACCT 105 or the equivalent accounting experience.

10359	L/L	MHG5	Brown R	3.30	2.0	M	0600P-0905P
Above class meets at Morgan Hill Community site.							

10364	L/L	HOL3	College A	3.30	2.0	F	0530P-0835P
Above class meets at the Hollister Briggs site. ROP class.							

ACCT 121 Spreadsheet - MS Excel

Transferable: CSU

Introduction to the computer spreadsheet software. A hands-on approach to learning terms, commands, and applications of a spreadsheet program. This course will help prepare students for taking the Excel MOUS (Microsoft Office User Specialist) exams. This course has the option of a letter grade or pass/no pass. May be repeated once for credit when the software changes. Also listed as CSIS 121. ADVISORY: CSIS 1 or CSIS 2 or equivalent computer experience.

10866	Lec	BU111	Conrey J	3.00	2.0	T	1120A-0210P
09/23/08 - 12/09/08							

10870	Lec	HOL3	Thompson F	3.30	2.0	T	0600P-0905P
09/23/08 - 12/09/08 Above class meets at the Hollister Briggs site.							

10958	Lec	BU111	Thompson F	3.30	2.0	W	0600P-0905P
-------	-----	-------	------------	------	-----	---	-------------

What is a CRN?

CRN stands for Course Reference Number. This is the number (used to be called section) that you will use to register for your classes.

**Credit Classes**

CD 35	Establishing Positive Behavior in the Classroom
CSIS 42	Python Programming
ITAL 8A	Conversational Italian
MUS 6	Introduction to World Music
ESL 585	Editing for ESL Writers
GUID 251	College Survival Skills
MKTG 100	Principles of Marketing

New Noncredit Classes

See the Noncredit section beginning on page 111.

ENGL 749	Writers' Workshop
ESL 777-782	ESL Lifeskills 1-6

Certificate of Achievement Computerized Accounting

16 units

Learn Computerized bookkeeping skills for a modern office.

ACCT/CSIS 120
Computerized Accounting

using *QuickBooks Pro*
Business Accounting Software



Now offered in Morgan Hill and Hollister.

Content includes general ledger, sales journal, cash receipts journal, cash payments journal, purchases journal, payroll, receivables, payables and related financial reports.

CRN Type Room Instructor Hrs. Units Days Begin-End

ACCT 190 Occupational Work Experience/Accounting

Transferable: CSU

College credit for learning experience obtained on the job in accordance with a training plan developed cooperatively between the employer, college and student. 75 hours per semester per unit or 60 hours per semester for unpaid experience. This is a pass/no pass course. May be taken for a maximum of 16 work experience units. REQUIRED: Declared vocational major. Concurrent enrollment in seven or more units (including CWE units, except for summer school. For summer school, enrollment in one other class is required). Minimum 2.00 G.P.A.

Mandatory course orientation for the following classes will be conducted Tuesday evening, September 23rd from 5:30-6:30 pm in BU117, Wednesday, Sept. 24th or Thursday Sept. 25th, from 12-1 p.m. in SC 154N. Students need to attend one of the three meetings. Please contact Lynda Kerr, CWE Coordinator at (408) 846-4993 for more information.

10094	Wrk Ex	BU125	Kerr L		1.0		
10095	Wrk Ex	BU125	Kerr L		2.0		
10096	Wrk Ex	BU125	Kerr L		3.0		
10098	Wrk Ex	BU125	Kerr L		4.0		

Acting: see Theatre Arts

AVIATION FLIGHT TECHNOLOGY

AFT 134 Aviation Flight Technology

Transferable: CSU

This course includes all aerodynamics, navigation, regulations, airport and airspace requirements, meteorology, and emergency procedures necessary to qualify for a private pilot certificate. ADVISORY: Completion of English 250 and English 260.

10510	Lec	PB14	Jackson C	3.30	3.0	T	0600P-0905P
-------	-----	------	-----------	------	-----	---	-------------

ALLIED HEALTH

AH 3 The Person in the Life Cycle

Transferable: CSU, UC; CSU-GE:E2; GAV-GE: E2, F

Interaction of social, emotional, intellectual, and physical attributes related to the development and realization of human potential across the life span. PREREQUISITE: Eligible for English 250 and English 260.

10082	Lec	LS106	Logan C	3.30	3.0	R	1250P-0355P
10512	Lec	LS106	Dufresne A	3.30	3.0	R	0400P-0705P
10513	Online	N/A	Bedell K		3.0		

 This online class will be delivered entirely over the Internet. After enrolling, start the class by going to <http://www.gavilan.edu/disted>, and log into the system. Students who have not logged in by 5 pm on the 3rd day may be dropped from the class.

AH 11 Nutrition

Transferable: CSU, UC; CSU-GE:E2; GAV-GE: E2, F; CAN:FCS2

This course is designed to meet the needs of the Allied Health student and the general education student alike. The major aim of this course is to help the student acquire relevant information about nutrition which they can use professionally and/or personally. The course will cover the practical aspects of normal nutrition, ways to promote sound eating habits throughout the life cycle, and physiological contribution nutrients make to body structure and function. This course is also listed as BIO 11. PREREQUISITE: Eligible for English 250 and English 260. ADVISORY: Chemistry 30A and Mathematics 205.

10514	Lec	LS106	Akrop M	3.30	3.0	T	1250P-0355P
10516	Lec	LS106	Akrop M	3.30	3.0	T	0400P-0705P
10518	Online	N/A	Akrop M		3.0		

 This online class will be delivered entirely over the Internet. After enrolling, start the class by going to <http://www.gavilan.edu/disted>, and log into the system. Students who have not logged in by 5 pm on the 3rd day may be dropped from the class. Dually listed course. Refer to Gavilan College Catalog.

CRN Type Room Instructor Hrs. Units Days Begin-End

AH 23 Independent Study

Transferable: CSU

Designed to afford selected students specialized opportunities for exploring areas at the independent study level. The courses may involve extensive library work, research in the community, or special projects. May be repeated until six units of credit are accrued. This course has the option of a letter grade or pass/no pass. REQUIRED: The study outline prepared by the student and the instructor must be filed with the department and the dean.

10521	Ind	HOB107	Bedell K		1.0		
-------	-----	--------	----------	--	-----	--	--

AH 32 Basic Cardiac Life Support

Transferable: CSU

Course designed to teach students skills in adult, child and infant cardiopulmonary resuscitation. Specifically designed for health professionals. Successful completion will result in certification by the American Heart Association or American Red Cross. This is a pass/no pass course. May be repeated up to three times for credit. Additional \$3.00 due upon completion for certification card.

10523	Lec	HOB114	Logan C	18.00	1.0	US	0800A-0500P
10/11/08 - 10/12/08 Short-term classes meet on specified dates. \$12 course material fee. Additional \$3.00 due upon completion for certification card.							

10528	Lec	HOB114	Logan C	18.00	1.0	US	0800A-0500P
09/13/08 - 09/14/08 Short-term classes meet on specified dates. \$12 course material fee. Additional \$3.00 due upon completion for certification card.							

AH 43 Interactive and Mental Health Nursing

Transferable: CSU

The dynamics of leadership and management in nursing, including concepts of basic mental health. Progresses from basic mental health knowledge and skills to the refinements involved in psychiatric nursing practice as it relates to all age groups. Incorporates nursing concepts and nursing experiences relative to human sexuality, child abuse and cultural and ethnic diversity. PREREQUISITE: Admission to the RN program and California IV certification. \$100 course material fee, payable at registration.

10063	L/L	HOB102	Turner S	13.80	0.0	MT	0130P-0815P
	L/L	HOB102	TBA	13.80		MT	0300P-0945P
	L/L	HOB102	Turner S	6.00		WR	1010A-0100P

AH 61 Medical-Surgical Nursing

Transferable: CSU

Course is designed to provide a basic introduction to patient care within the role of the vocational nurse. Emphasizes principles and skills necessary for safe, effective care. Content includes introduction to health care, effective communication, client rights and needs, asepsis, personal care, safety, and gerontology. Related pharmacology is included. PREREQUISITE: Admission to the LVN Program. \$100 course material fee, payable at registration.

10575	L/L	HOB102	Stubblefield L	15.60	1.0	MT	0630A-0200P
	L/L	HOB102	TBA	15.60		MT	0630A-0200P
	L/L	HOB102	Stubblefield L	6.00		WR	0710A-1000A

AH 63 Medical-Surgical/Maternal-Neonatal Nursing

Transferable: CSU

Course contains two components to provide theoretical and clinical experience in medical-surgical and maternal-neonatal nursing. Content includes care of clients with disorders of the circulatory, urinary and reproductive systems, normal pregnancy and birth, common or major complications, care of the normal newborn, and neonate with special problems. Related pharmacology is included. PREREQUISITE: Successful completion of Allied Health 61 and 62 with a grade of C or better or equivalent. Equivalency determined by written and performance exams. \$100 course material fee, payable at registration.

10576	L/L	HOB102	Amaro D	15.60	1.0	MT	0630A-0200P
	L/L	HOB102	TBA	15.60		MT	0200P-0930P
	L/L	HOB102	Amaro D	6.00		WR	0110P-0400P

APPLY & REGISTER Online

Go to www.gavilan.edu and click on the Self-Service Banner icon.

Classroom Locations: Refer to "How to Use This Schedule" on page 6.

CRN Type Room Instructor Hrs. Units Days Begin-End

AH 170 Basic Clinical Medical Assisting

Transferable: CSU

Course provides a basic introduction to clinical medical assisting. Emphasizes principles, understanding of skills necessary to perform basic clinical medical assisting procedures safely and effectively. PREREQUISITE: Eligible for English 250, English 260 and Mathematics 205.

10577 L/L HOB114 Kearbey A 13.20 6.0 TWR 1250P-0430P
ROP class.

AH 180 Fundamentals of Nursing--Convalescent

Transferable: CSU

A course to provide a basic introduction to patient care in the convalescent setting. Emphasizes principles, understanding and skills necessary to perform basic nursing procedures safely and effectively. Includes introduction to health care, planning, safety, infection control, personal care, basic procedures, rehabilitation, nutrition and clients' rights and needs. At the completion of this course students will qualify for state certification as a nursing assistant. PREREQUISITE: Eligible for English 250 and English 260. Clearance from the Department of Health Services (Form HS283), fingerprint card, and health clearance required prior to clinical placement. Health and fingerprint clearance required prior to clinical placement. Uniform, shoes, watch, and stethoscope required. Clinical in Morgan Hill or Hollister, as assigned.

10578 L/L HOB114 Machado M 6.00 8.0 MT 0910A-1200P
L/L HOB114 Machado M 7.00 W 0630A-0130P
ROP class.

10580 L/L HOB114 Machado M 6.00 8.0 MT 0910A-1200P
L/L HOB114 Machado M 7.00 R 0630A-0130P
ROP class.

AH 182 Home Health Care

Transferable: CSU

Course is designed to prepare students to provide basic health care in the home. Includes interpretation of medical/social needs, personal care services, cleaning tasks, nutrition, and the scope of limitations of a home health aide. All students who achieve a grade of "C" or better will be eligible for a Home Health Aide certificate from the State of California. PREREQUISITE: California CNA certification or concurrent enrollment in AH 180 or equivalent. Equivalency determined by written and performance exams. Also, eligible for English 250 and English 260. Clearance from the Department of Health Services (Form HS283), fingerprint card, and health clearance required prior to clinical placement.

10582 L/L HOB114 Machado M 7.00 2.0 S 0630A-0130P
10/11/08 - 11/15/08 Short-term class meets on specified dates. ROP class.

AH 190 Occupational Work Experience/Allied Health

Transferable: CSU

College credit for learning experience obtained on the job in accordance with a training plan developed cooperatively between the employer, college and student. 75 hours per semester per unit or 60 hours per semester for unpaid experience. This is a pass/no pass course. May be taken for a maximum of 16 work experience units. REQUIRED: Declared vocational major. Concurrent enrollment in seven or more units (including CWE units, except for summer school. For summer school, enrollment in one other class is required). Minimum 2.00 G.P.A. Please contact the Allied Health Department at (408) 848-4883 for more information.

10586 Wrk Ex HOB114 Bedell K 1.0
10590 Wrk Ex HOB114 Bedell K 2.0
10594 Wrk Ex HOB114 Bedell K 3.0
10595 Wrk Ex HOB114 Bedell K 4.0

What is a **CRN**?

CRN stands for Course Reference Number. This is the number (used to be called section) that you will use to register for your classes.

GAVILAN COLLEGE BOOKSTORE

Student Center

408-848-4742

- NEW BOOKS
- USED BOOKS (25% LESS THAN NEW)
- BOOK BUY BACK

GET OUT OF LINE ● GET ON LINE

Order your textbooks @ www.gavilan.BKSTR.com

RETURN Policy: Refunds given UP TO SEVEN DAYS from start of class.
Always have your receipt.
Always make sure new books have not been written in.
Shrink wrap sets should be returned with all enclosures.

We accept all major credit cards and checks with ID

HOURS
Mon-Tues 8:00 am - 7:00 pm
Wed-Thurs 8:00 am - 5:00 pm
Friday 8:00 am - 1:00 pm

EXTENDED FALL HOURS
During the first two weeks of fall semester the bookstore will remain open Monday-Thursday until 7 pm, Friday until 5:30 pm and Saturday (Sept. 6 only) from 9 am - 2 pm.

Get College Credit for Working or Volunteering!



Cooperative Work Experience

is available to day, evening, full-time and part-time students.

If your job or volunteer work is directly related to your education or occupational goals sign up for:

CWE 190: Occupation Work Experience Education

If your job or volunteer work is not directly related to your educational goals sign up for:

CWE 192: General Work Experience Education

Call 408-846-4993 for more information.

CRN Type Room Instructor Hrs. Units Days Begin-End

ADMINISTRATION OF JUSTICE

AJ 10 Introduction to the Administration of Justice

Transferable: CSU, UC; CAN:AJ2

The history and philosophy of justice as it evolved throughout the world; in-depth study of the American system and various sub-systems; roles and role expectations of criminal justice agents in their interrelationships in society; concepts of crime causations, punishments and rehabilitation; ethics, education and training for professionalism in the social system. ADVISORY: Eligible for English 250 and English 260.

10252	Lec	BU118	Smith S	3.20	3.0	MW	1120A-1240P
10278	Lec	BU120	Smith S	3.20	3.0	MW	0810A-0930A

AJ 12 Criminal Procedures

Transferable: CSU

Legal processes from pre-arrest, arrest through trial, sentencing and correctional procedures; a review of the history of case and common law; conceptual interpretations of law as reflected in court decisions; a study of case law methodology and case research as the decisions impact upon the procedures of the justice system. ADVISORY: Eligible for English 250 and English 260.

10256	Lec	MHG12	Smith S	3.30	3.0	T	0250P-0555P
-------	-----	-------	---------	------	-----	---	-------------

Above class meets at Morgan Hill Community site.

AJ 14 Criminal Law

Transferable: CSU, UC; CAN:AJ4

Historical development, philosophy of law and constitutional provisions; definitions, classifications of crime, and their applications to the system of administration of justice; legal research, review of case law, methodology, and concepts of law as a social force. Explores crimes against persons, property, and the state. ADVISORY: Eligible for English 250 and English 260.

10280	Lec	BU120	Smith S	3.20	3.0	MW	1250P-0210P
-------	-----	-------	---------	------	-----	----	-------------

AJ 16 Introduction to Evidence

Transferable: CSU

Origin, development, philosophy and constitutional basis of evidence; constitutional and procedural considerations affecting arrest, search and seizure; kinds and degrees of evidence and rules governing admissibility; judicial decisions interpreting individual rights and case studies viewed from a conceptual level. ADVISORY: Eligible for English 250 and English 260.

10291	Lec	BU118	Campos E	3.20	3.0	TR	1120A-1240P
-------	-----	-------	----------	------	-----	----	-------------

AJ 18 Community and Human Relations

Transferable: CSU, UC

The relationship of criminal justice agents and the community; causal and symptomatic aspects of community understanding; lack of cooperation and mistrust; study of behavioral causes; ways to develop and maintain amicable relationships. ADVISORY: Eligible for English 250 and English 260.

10286	Lec	MHG10	Jones W	3.30	3.0	W	0630P-0935P
-------	-----	-------	---------	------	-----	---	-------------

Above class meets at Morgan Hill Community site.

AJ 19 Introduction to Investigation

Transferable: CSU

Fundamentals of investigation; techniques of crime scene search and recording; collection and preservation of physical evidence; modus operandi processes; sources of information; interview and interrogation, and follow-up investigation. ADVISORY: Eligible for English 250 and English 260.

10288	Lec	MHG3	Jones W	3.30	3.0	M	0630P-0935P
-------	-----	------	---------	------	-----	---	-------------

Above class meets at Morgan Hill Community site.

AJ 20 Juvenile Law and Procedure

Transferable: CSU

Techniques of handling juvenile offenders and victims; prevention and repression of delinquency; diagnosis and referral; organization of community resources. Juvenile law and juvenile court procedure. ADVISORY: Eligible for English 250 and English 260.

10271	Lec	BU118	Campos E	3.20	3.0	TR	0945A-1105A
-------	-----	-------	----------	------	-----	----	-------------

CRN Type Room Instructor Hrs. Units Days Begin-End

AJ 21 Narcotics and Drug Abuse

Transferable: CSU

Designed to explore the Administration of Justice system and drug problems: drug identification, drug user recognition, drug effects, narcotic enforcement, drug prosecution, drug treatment, rehabilitation and education. ADVISORY: Eligible for English 250 and English 260.

10295	Lec	MHG3	Smith S	3.30	3.0	R	0300P-0605P
-------	-----	------	---------	------	-----	---	-------------

Above class meets at Morgan Hill Community site.

AJ 32 Crime and Delinquency

Transferable: CSU

An introduction to major types of criminal behavior, characteristics of offenders, factors which contribute to crime and delinquency; the criminal justice process: the function of law enforcement, the courts, probation, parole and institutions; changes in crime control and treatment processes, the role of society. ADVISORY: Eligible for English 250 and English 260.

10296	Lec	MHG11	Pulido D	3.30	3.0	T	0630P-0935P
-------	-----	-------	----------	------	-----	---	-------------

Above class meets at Morgan Hill Community site.

AJ 173 Fundamentals of Probation and Parole

Transferable: CSU

Theory and techniques of probation/parole supervision, including historical development with emphasis on recent programs, research, and development in the field. ADVISORY: Eligible for English 250 and English 260.

10299	Lec	MHG10	Pulido D	3.30	3.0	R	0600P-0905P
-------	-----	-------	----------	------	-----	---	-------------

Above class meets at Morgan Hill Community site.

AJ 190 Occupational Work Experience/Administration of Justice

Transferable: CSU

College credit for learning experience obtained on the job in accordance with a training plan developed cooperatively between the employer, college and student. 75 hours per semester per unit or 60 hours per semester for unpaid experience. This is a pass/no pass course. May be taken for a maximum of 16 work experience units. REQUIRED: Declared vocational major. Concurrent enrollment in seven or more units (including CWE units, except for summer school. For summer school, enrollment in one other class is required). Minimum 2.00 G.P.A.

Mandatory course orientation for the following classes will be conducted Tuesday evening, September 23rd from 5:30-6:30 pm in BU117, Wednesday, Sept. 24th or Thursday Sept. 25th, from 12-1 p.m. in SC 154N. Students need to attend one of the three meetings. Please contact Lynda Kerr, CWE Coordinator at (408) 846-4993 for more information.

10058	Wrk Ex	BU125	Kerr L		1.0		
10059	Wrk Ex	BU125	Kerr L		2.0		
10061	Wrk Ex	BU125	Kerr L		3.0		
10062	Wrk Ex	BU125	Kerr L		4.0		

Anatomy: see Biological Sciences

ANTHROPOLOGY

ANTH 1 Introduction to Physical Anthropology

Transferable: CSU, UC; CSU-GE:B2; IGETC:5B; GAV-GE:B2; CAN:ANTH2

Survey study of human biological, social and cultural development over the last several million years. The implications of evolutionary theory for the world today are also considered. Principal topics are evolutionary theory, Mendelian and molecular genetics, the fossil record, primatology, the nature of human diversity "race", and the question of continuing evolution. ADVISORY: English 250, English 260 and Mathematics 205.

10205	Online	N/A	Klein D		3.0		
-------	--------	-----	---------	--	-----	--	--

This online class will be delivered entirely over the Internet. After enrolling, start the class by going to <http://www.gavilan.edu/disted>, and log into the system. Students who have not logged in by 5 pm on the 3rd day may be dropped from the class.

10207	Lec	SS210	Klein D	3.20	3.0	MW	1250P-0210P
10209	Lec	HOL2	Etier D	3.30	3.0	M	0600P-0905P

Above class meets at the Hollister Briggs site.

Classroom Locations: Refer to "How to Use This Schedule" on page 6.

CRN Type Room Instructor Hrs. Units Days Begin-End

ANTH 2 Introduction to Archaeology

Transferable: CSU, UC; CSU-GE:D1; IGETC:4A; GAV-GE:D2

Introduction to history and development of the concepts and methods of anthropological archaeology, a survey of selected prehistoric cultures, and some training in archaeological survey methods, site recognition, recordation and preservation as well as cultural resource management. ADVISORY: Recommended English 250 and English 260.

10210 Lec SS216 Etler D 3.20 3.0 MW 0945A-1105A

ANTH 3 Introduction to Cultural Anthropology

Transferable: CSU, UC; CSU-GE:D1; IGETC:4A; GAV-GE:F; CAN:ANTH4

The comparative study of human societies and cultures. Emphasis is placed on the analysis of small scale non-western societies. Specific topics include the nature of culture, the enculturation process, kinship systems and the cross-cultural analysis of religious, political and economic institutions. Culture change and the relevance of anthropology for understanding the modern world are also considered. ADVISORY: Eligible for English 250 and English 260.

10211 Lec SS205 Klein D 3.20 3.0 TR 0945A-1105A

10213 Lec SS205 Klein D 3.20 3.0 MW 0230P-0350P

This service learning course section involves community work

ANTH 5 Magic/Witchcraft and Religion

Transferable: CSU, UC; CSU-GE:D1; IGETC:4A; GAV-GE:D2

Cross cultural study of beliefs and practices with respect to the supernatural, health/wellness and healing, myth, ritual, witchcraft, magic, symbolism, altered states of consciousness, and revitalization. Also connection and reflection of cultural contexts in which they are found. ADVISORY: English 250 and English 260.

10214 Lec SS205 Klein D 3.20 3.0 TR 1120A-1240P

ANTH 9 Cultural Context of Childhood

Transferable: CSU; CSU-GE:D7; GAV-GE:D2, F

This course examines cultural influences on child-rearing practices, family values, and human development. Perspectives from the social sciences will be used to explore what is common to all Homo sapiens and what is specific to the culture of the United States. Students will explore their personal assumptions and attitudes towards diversity, and practice implementing non-stereotypical, developmentally appropriate, anti-bias activities, interactions and environments in order to respond to and intervene against prejudice among children. This course is also listed as CD 7 and PSYC 7.

10170 Lec MHG4 Bumgarner M 3.20 3.0 MW 1120A-1240P

Above class meets at Morgan Hill Community site.

ART

ART 1A Art History

Transferable: CSU, UC; CSU-GE:C1; IGETC:3A; GAV-GE:C1; CAN:ART2, ART SEQ A

A critical survey of the influences and development of painting, architecture, sculpture, and minor arts from pre-history to the Byzantine/Romanesque eras, including the art of primitive people. ADVISORY: Eligible for English 250 and English 260.

10538 Lec PB5 Martinez E 3.30 3.0 T 0600P-0905P

ART 1B Art History

Transferable: CSU, UC; CSU-GE:C1; IGETC:3A; GAV-GE:C1; CAN:ART4, ART SEQ A

The history of western painting, sculpture, architecture and minor arts from the Romanesque, the Gothic and Renaissance eras to the present. ADVISORY: Eligible for English 250 and English 260.

10541 Lec MHG12 Crispi I 3.30 3.0 R 0600P-0905P

Above class meets at Morgan Hill Community site.

ART 2A Two-Dimensional Design

Transferable: CSU, UC; CSU-GE:C1; GAV-GE:C1; CAN:ART14

An introduction to the basic elements and principles of two-dimensional design. Lettering and graphics applications of design are included. Traditional and experimental materials and techniques are applied to a variety of individual projects and exercises.

10542 L/L PB7 Thomas B 6.60 3.0 TR 0810A-1115A

ALUMNI

Laleh Esmali



I found a lot of support at Gavilan College, especially after joining the MESA program on campus. I was intimidated by school at first, but learned to adapt by becoming very involved. I worked as a tutor, formed friendships with my teachers, and helped out at events like Science Alive! My teachers also supported me by writing letters of recommendations for my applications to internships, and now I'm preparing for my second summer of working at a research laboratory.

My advice to students in all majors is to examine all of the opportunities available to you until you find something that you're really passionate about. And then give back by mentoring other students on similar paths.



Gavilan College has been providing quality Administration of Justice education and training for over 39 years. So, when you want to begin your career in Law Enforcement, you can go to the same place where thousands of Northern California law enforcement officers got their start!

Gavilan College is a member of the South Bay Regional Public Safety Training consortium. This consortium is funded by all colleges regionally to provide vocational specific training which may require special facilities, special training conditions or is presented outside of schedules of regular college classes.

Careers in:

- Law Enforcement
- Probation Officer
- Corrections Officer
- Fire Technology
- Dispatcher
- Juvenile Hall Counselor



www.gavilan.edu/aj
or call (408) 270-6458

CRN Type Room Instructor Hrs. Units Days Begin-End

ART 3A Drawing and Composition

Transferable: CSU, UC; CSU-GE:C1; GAV-GE:C1; CAN:ART8

A course that can teach you how to draw. Students learn basic drawing skills through the exploration of a variety of drawing materials such as pencil, inks, charcoal and pastels; processes include doodling, gesture and schematic drawing.

10543	L/L	PB8	Rosette A	6.60	3.0	MW	0810A-1115A
10544	L/L	PB8	Rosette A	6.60	3.0	TR	0810A-1115A

ART 6 Art Appreciation

Transferable: CSU, UC; CSU-GE:C1; IGETC:3A; GAV-GE:C1

An illustrated lecture course that surveys and introduces the visual arts from historical to contemporary times, and teaches students the basic concepts of seeing and appreciating art. ADVISORY: English 250 and English 260.

10547	Lec	PB7	Edberg J	3.20	3.0	MW	1120A-1240P
10548	Online	N/A	Edberg J	3.0			

This online class will be delivered entirely over the Internet. After enrolling, start the class by going to <http://www.gavilan.edu/disted>, and log into the system. Students who have not logged in by 5 pm on the 3rd day may be dropped from the class.

ART 8A Beginning Photography from Analog to Digital

Transferable: CSU, UC; CSU-GE:C1; GAV-GE:C1; CAN:ART18

A beginning photography course focused on the technical and historical aspects of photography from analog to digital. This course includes the development of personal artistic expression and visual perception through the use of various photographic medium. The course will include lectures and discussions about composition and content, analog and digital camera use, lighting and exposure, various photographic processes, and photographic presentation techniques. Alternative methods, mixed media and experimental forms of photography will also be discussed. Students will be required to provide their own camera, and film.

10549	L/L	PB7	Edberg J	6.60	3.0	TR	1120A-0225P
-------	-----	-----	----------	------	-----	----	-------------

ART 10A Cultural History of Ceramics

Transferable: CSU, UC; CSU-GE:C1; GAV-GE:F; CAN:ART6

An introduction to the historical developments and cultural influences of ceramic art. Development of a personal expression is realized through the combination of historical elements, observation and actual creations in clay.

10550	L/L	PB9	Rekedal J	5.40	3.0	MW	0845A-1110A
10551	L/L	PB9	Rekedal J	5.40	3.0	MW	1120A-0145P
10552	L/L	PB9	Gonzales K	5.40	3.0	TR	0600P-0825P

ART 10B Ceramics

Transferable: CSU, UC; GAV-GE:C1

Emphasis on development of wheel throwing and advanced ceramic techniques. Glaze testing, clay body development, kiln stacking and firing are introduced. May be repeated three times for credit. This course has the option of a letter grade or pass/no pass. ADVISORY: Art 10A

10553	L/L	PB9	Gonzales K	6.60	3.0	TR	0600P-0905P
-------	-----	-----	------------	------	-----	----	-------------

ART 11 Creativity/Imagination and Innovation

Transferable: CSU; CSU-GE:C2; GAV-GE:F

This course is designed to explore the variety of ways in which humans demonstrate their creative, imaginative and innovative abilities. This course will examine the creative process, visual literacy, the development of creative and imaginative performance and theories pertaining to insight, inspiration, intuition, originality and genius. This class draws on materials from a variety of sources including, biographies, intellectual histories, psychological studies, and educational research. Studies will include ideas and beliefs about creativity from a diverse range of disciplines and cultures. Students will be encouraged to explore and express their own creativity. ADVISORY: English 250 and English 260.

10554	Lec	PB8	Juncker A	3.20	3.0	TR	1120A-1240P
-------	-----	-----	-----------	------	-----	----	-------------

CRN Type Room Instructor Hrs. Units Days Begin-End

ART 13 Three-Dimensional Design

Transferable: CSU, UC; CSU-GE:C1; GAV-GE:C1

A fundamental course focused on the technical and historical aspects of three dimensional design and sculpture. Development of personal artistic expression and visual perception through the use of various sculpting media such as plaster, paper, wood, clay, metal, etc. Introduction to the design elements and principles as they relate to space and form in visual art and design will be studied. ADVISORY: English 250 and English 260.

10556	L/L	PB9	Allen F	6.60	3.0	TR	1120A-0225P
-------	-----	-----	---------	------	-----	----	-------------

ART 14 Beginning Mural Painting

Transferable: CSU, UC; CSU-GE:C1; GAV-GE:C1

Studio practice in the design, methods and materials of mural painting through the production of individual and collaborative murals. The course will also provide a historical survey of mural painting, from pre-historic cave painting to contemporary urban murals, with particular focus on the muralists of Mexico. May be repeated three times for credit. This course has the option of a letter grade or pass/no pass.

10563	L/L	PB8	Rosette A	4.30	3.0	F	0900A-0105P
	ARR		Rosette A	2.30			

This service learning course section involves community work

ART 15A Beginning Painting: Form and Composition

Transferable: CSU, UC; GAV-GE:C1

This is an introductory painting course. Students will study traditional, contemporary and experimental painting techniques using acrylics and/or oils as the primary media. Emphasis will be placed on foundational concepts and approaches including color, form and composition. May be repeated once for credit. This course has the option of a letter grade or pass/no pass. ADVISORY: Art 2A or 3A, or portfolio review of student's work.

10564	L/L	PB8	Webster E	6.60	3.0	MW	1120A-0225P
-------	-----	-----	-----------	------	-----	----	-------------

ART 15B Beginning Painting: Imagination and Expression

Transferable: CSU, UC; GAV-GE:C1

This is an introductory painting course. Students will study traditional, contemporary and experimental painting techniques and media. Social, cultural and historical awareness are integrated with classroom explorations of expressive painting. Students develop a variety of painting approaches and a greater understanding of personal expression. May be repeated once for credit. This course has the option of a letter grade or pass/no pass. ADVISORY: Art 2A or Art 3A or Portfolio Review

10565	L/L	PB8	Webster E	6.60	3.0	MW	1120A-0225P
-------	-----	-----	-----------	------	-----	----	-------------

ART 21 Ancient Americas: A History through Art

Transferable: CSU, UC; CSU-GE:C2, C1; IGETC:3A; GAV-GE:C2, F

A critical survey of history through the arts of pre-Columbian natives of North, Central and South America. The course will cover major societies and events from the appearance of major civilizations through the initial colonization efforts of European nations. Due to the distinct history of the Americas, this course uses the arts - architecture, sculpture, ceramics and painting, among others - of ancient societies as a primary source material. This course has the option of a letter grade or pass/no pass. This course is also listed as HIST 21. ADVISORY: Eligible for English 250.

10567	Lec	HOL5	Martinez E	3.20	3.0	TR	0230P-0350P
-------	-----	------	------------	------	-----	----	-------------

Above class meets at the Hollister Briggs site.

ART 22 Field Work and Service

Transferable: CSU

Supervised field work within the college and with local agencies. Students serve in useful group activities in leadership roles prescribed for them by faculty or community agencies. A maximum of six units may be completed. This is a pass/no pass course. REQUIRED: Learning contracts must be filled out and signed by the student and the supervising instructor.

10571	Fld Ex	PB7	Edberg J	1.0			
10573	Fld Ex	PB11-Q	Gonzales K	1.0			
10579	Fld Ex	PB8	Rosette A	1.0			
10581	Fld Ex	PB11-Q	Rekedal J	1.0			

CRN Type Room Instructor Hrs. Units Days Begin-End

ART 23 Independent Study

Transferable: CSU

Designed to afford selected students specialized opportunities for exploring areas at the independent study level. The courses may involve extensive library work, research in the community, or special projects. May be repeated until six units of credit are accrued. This course has the option of a letter grade or pass/no pass. REQUIRED: The study outline prepared by the student and the instructor must be filed with the department and the dean.

10583	Ind	PB7	Edberg J	1.0
10584	Ind	PB7	Edberg J	2.0
10585	Ind	PB11-Q	Rekedal J	1.0
10587	Ind	PB11-Q	Rekedal J	2.0
10588	Ind	PB8	Rosette A	1.0
10589	Ind	PB8	Rosette A	2.0
10591	Ind	PB11-Q	Gonzales K	1.0

ART 25A Art Methods

Transferable: CSU; CSU-GE:C1; GAV-GE:C1

Art methods and learning theory for those planning to work with preschool, elementary and secondary school students. Includes art therapy as well as gifted and special learner projects. Two dimensional work in printing, drawing, collage. Also listed as CD 25A.

10190	L/L	HOL1	McGinnis R	4.30	3.0	F	0400P-0805P
	ARR		McGinnis R	2.30			
Above class meets at the Hollister Briggs site.							
10592	L/L	PB7	Webster E	4.30	3.0	F	0900A-0105P
	ARR		Webster E	2.30			

ART 25B Art Methods

Transferable: CSU; GAV-GE:C1

Art methods, creativity and learning theory for those planning to work with preschool, elementary, and secondary school students. Includes art therapy as well as gifted and special learner projects. Three dimensional work in sculpture, bas relief, mobiles, paper mache', plaster, and various 3-D materials. Also listed as CD 25B.

10192	L/L	HOL1	McGinnis R	4.30	3.0	F	0400P-0805P
	ARR		McGinnis R	2.30			
Above class meets at the Hollister Briggs site.							

ART 34A Life Drawing

Transferable: CSU, UC; GAV-GE:C1; CAN:ART24

Fundamentals of anatomy and representation of the human figure. Drawing from life. May be repeated once for credit. This course has the option of a letter grade or pass/no pass. ADVISORY: Art 3A or review of student's portfolio.

10545	L/L	PB8	Adkins J	6.30	3.0	F	0200P-0805P
-------	-----	-----	----------	------	-----	---	-------------

ART 34B Life Drawing

Transferable: CSU, UC; GAV-GE:C1

Further studies of the fundamentals of anatomy and representation of the human figure. Emphasis is placed on personal expression; abstract and experimental processes. May be repeated once for credit. This course has the option of a letter grade or pass/no pass. ADVISORY: Art 34A or review of student's portfolio.

10546	L/L	PB8	Adkins J	6.30	3.0	F	0200P-0805P
-------	-----	-----	----------	------	-----	---	-------------

ART 40 Art Gallery Assistance

Transferable: CSU; GAV-GE:C1

Individualized course in art gallery exhibition techniques and procedures. Students assist in design, installation, publicity, cataloguing and removal of exhibitions in the college gallery. May be taken until 4 units are accrued.

10593	Fld Ex	PB8	Rosette A	1.0
-------	--------	-----	-----------	-----

GET INVOLVED!

Help paint murals in your own community!

ART 14 Beginning Mural Painting



This class offers studio practice in the design, methods and production of individual and collaborative murals and a historical survey of mural painting.

Satisfies CSU General Education (Area C-1) and the ARTS Gavilan College graduation requirement (AREA C-1)

ART 21
Ancient America:
A History Through Art



Also listed as History 21

ART 21 Satisfies the CSU Humanities requirement (AREA C-2) and the UC/CSU ARTS requirement under the IGETC pattern.

ART 10A/B

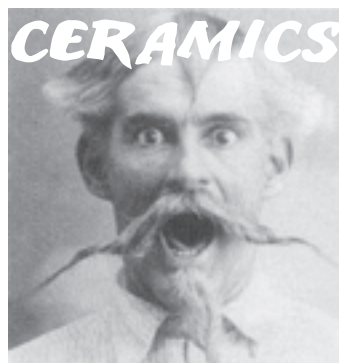

Get Your Groove On
Learn How to Throw Pots
Like me, The World's
Greatest Potter!
George Ohr
AKA: Mad Potter of Biloxi

ART 10A CRN# 10550 MW 8:45-11:10am
CRN# 10551 MW 11:20am-1:45pm
CRN#10552 TTh 6:00pm-8:25pm

ART 10B CRN# 10553 TTh 6:00pm- 9:05pm

CRN Type Room Instructor Hrs. Units Days Begin-End

ART 74 Advanced Photoshop

Transferable: CSU; GAV-GE:C1

This course is for the PhotoShop-experienced student and explores PhotoShop's advanced features in depth. Students work on projects, which challenge their creativity and technical ability, and will be encouraged to develop complex projects for the web and for the printed page. May be repeated three times for credit. This course has the option of a letter grade or pass/no pass. This course is also listed as CSIS 74 and DM 74. ADVISORY: CSIS 75 PhotoShop I

10614	Lec	MHG5	Grzan R	3.30	3.0	R	0630P-0935P
Above class meets at Morgan Hill Community site.							

ART 75 PhotoShop I

Transferable: CSU; GAV-GE:C1

This course is based on the software Adobe PhotoShop. Students learn to scan photographs and manipulate them using PhotoShop tool box and special effects filters. They will learn to color correct photos; mask image using channels; create duotone, tritone, and quadtone images; prepare photos for use in printing and on the web. This course has the option of a letter grade or pass/no pass. May be repeated three times for credit. ADVISORY: CSIS 124 (Windows Fundamentals), CSIS 2L

10617	L/L	LI128	Beede R	3.20	3.0	MW	0945A-1105A
10624	L/L	MHG5	Grzan R	3.30	3.0	T	0630P-0935P
Above class meets at Morgan Hill Community site.							

ART 77 Introduction to Digital Media

Transferable: CSU, UC; GAV-GE:C1

An introduction to the field of digital media, including history, social impact, concepts, career options and industry trends. Applying learned visual and aural design principles, students will explore the use of computer-based tools in the design and production of digital media by creating and editing digital images, sounds, video, animation and text. A comprehensive term project for publication on the web or CD ROM will be required. This course is also listed as CSIS 77 and DM 77. This course has the option of a letter grade or pass/no pass. May be repeated twice for credit. ADVISORY: CSIS 124, CSIS 1, CSIS 2.2L, CSIS 3, or familiarity using the Macintosh or Windows operating systems.

10633	L/L	LI128	Beede R	3.20	3.0	TR	1120A-1240P
-------	-----	-------	---------	------	-----	----	-------------

ART 80 Digital Photography

Transferable: CSU, UC; GAV-GE:C1

The study of digital photography from digital camera to the computer-based printer or digital media. Artistic, theoretical, and technical aspects will be considered. Topics include information about types and purchasing of digital cameras; theory, mechanics, and art of digital imagery; digital darkroom; eccentricities of digital photo taking; stitching photos for virtual reality; and preparing digital images for print, World Wide Web and other digital media. This course has the option of a letter grade or pass/no pass. This course is also listed as DM 80 and CSIS 80. ADVISORY: CSIS 1 or CSIS 2/2L or ART 8A or equivalent computer experience. \$20 materials fee, payable at registration.

10640	L/L	LI128	Edberg J	5.40	3.0	MW	1250P-0315P
-------	-----	-------	----------	------	-----	----	-------------

ART 85 Web Design I: Dreamweaver

Transferable: CSU; GAV-GE:C1

Basic and intermediate principles of designing Web pages/sites using the Dreamweaver web design software and HTML. Emphasis will be on good design and the use of tables, frames, forms, rollovers, DHTML, XHTML, behaviors, and CSS. Also includes site maintenance and the integration of multimedia components such as graphics, sound, animation, and video. This course is for the content person to design, develop, and maintain effective Web sites. This course is also listed as CSIS 85 and DM 85. This course has the option of a letter grade or pass/no pass. May be repeated twice for credit. ADVISORY: CSIS 6 or basic knowledge of HTML.

10662	Lec	MHG8	Conrey J	3.30	2.0	W	0600P-0905P
09/24/08 - 12/10/08 Above class meets at Morgan Hill Community site.							

ART 110 Interactive Animation: Flash

Transferable: CSU; GAV-GE:C1

The production of vector graphics, animation, and interactive multimedia in Shockwave-Flash format for web pages and other digital media. Design of highly interactive web site interfaces and animated games using Flash actions (scripting). Useful for web designers/developers, animators, and multimedia authors. This course has the option of a letter grade or pass/no pass. Also listed as CSIS 110 and DM 110. May be repeated three times for credit. ADVISORY: CSIS 1, CSIS 2/2L, CSIS 124 or basic computer knowledge.

10682	L/L	LI128	Beede R	3.20	3.0	MW	1120A-1240P
-------	-----	-------	---------	------	-----	----	-------------

CRN Type Room Instructor Hrs. Units Days Begin-End

ART 113 Introduction to Digital Video

Transferable: CSU; GAV-GE:C1

Introduction to the aesthetic and technical aspects of digital video recording, non-linear editing, special effect generation, and production of video (and associated audio) using the personal computer equipped with specialized software such as iMovie, Final Cut Pro, and After Effects. Also considered will be the preparation of digital video for use in interactive media such as CD, DVD, and the World Wide Web. Students will produce a final digital video project on DVD. This course has the option of a letter grade or pass/no pass. May be repeated two times for credit. Also listed as CSIS 113 and DM 113. ADVISORY: CSIS 1 or CSIS 2/2L or equivalent computer experience

10731	L/L	LI128	Beede R	3.20	3.0	TR	0945A-1105A
-------	-----	-------	---------	------	-----	----	-------------

ART 140 Basic Digital Film/Video Production

Transferable: CSU, UC; GAV-GE:C1

An on-line self-paced course covering the basics of film/video production and post production (editing) using "easy to use" computer software such as Apple's iMovie. Beneficial for students who are producing a video/film project as a requirement for another college course, extra skills development, or for self interest. Completion of the associated class or personal project in DVD format using either personal video equipment or the equipment in the Digital Media Studio is required. May be repeated twice for credit. This course has the option of a letter grade or pass/no pass. This course is also listed as DM 140 and CSIS 140.

10908	Online	N/A	Beede R		1.0		
 This online class will be delivered entirely over the Internet. After enrolling, start the class by going to http://www.gavilan.edu/disted , and log into the system. Students who have not logged in by 5 pm on the 3rd day may be dropped from the class.							

ART 190 Occupational Work Experience/Commercial Art

Transferable: CSU; GAV-GE:C1

The application of learned theory, knowledge, and skills to a practical job setting related to the student's educational/occupational goal. Employment must be directly related to the student's college educational/occupational goal. Periodic interviews of the students and employers or their representatives will be required. Each student shall be assisted in the development of individualized performance objectives, toward which the learning experience shall be directed. REQUIRED: Enrollment in a minimum of seven (7) units, including Cooperative Work Experience, during regular semesters; enrollment in at least one other class in summer session.

Mandatory course orientation for the following classes will be conducted Tuesday evening, September 23rd from 5:30-6:30 pm in BU117, Wednesday, Sept. 24th or Thursday Sept. 25th, from 12-1 p.m. in SC 154N. Students need to attend one of the three meetings. Please contact Lynda Kerr, CWE Coordinator at (408) 846-4993 for more information.

10132	Wrk Ex	BU125	Kerr L		1.0		
10133	Wrk Ex	BU125	Kerr L		2.0		
10134	Wrk Ex	BU125	Kerr L		3.0		
10135	Wrk Ex	BU125	Kerr L		4.0		

ASTRONOMY

ASTR 1 Introduction to General Astronomy

Transferable: CSU, UC; CSU-GE:B1; IGETC:5A; GAV-GE:B1

An introduction to the realm of astronomy and space science. Topics to be covered include the historical development of astronomy, the physics of gravitation and radiation, the solar system, stellar astronomy, galactic and extragalactic astronomy, and cosmology. ADVISORY: Mathematics 205 and eligible for English 250 and English 260.

10788	Lec	CH102	Bumgarner J	3.30	3.0	T	0230P-0535P
10789	Lec	MHG13	Bumgarner J	3.30	3.0	T	0600P-0905P
Above class meets at Morgan Hill Community site.							
10790	Lec	HOL1	Snyder J	3.30	3.0	M	0600P-0905P
Above class meets at the Hollister Briggs site.							

The Final Word!

Look for the Final Exams schedule on page 117 of this schedule.

Classroom Locations: Refer to "How to Use This Schedule" on page 6.

CRN Type Room Instructor Hrs. Units Days Begin-End

Athletics: see Physical Education (PE)

Beauty School: see Cosmetology

AVIATION MAINTENANCE TECHNOLOGY

Aviation classes begin early: Check start dates below

AMT 100 General Aircraft Technology

Transferable: CSU

This course will provide the student with a thorough understanding of the use of basic hand tools and measuring devices, aircraft hardware, materials, and processes, mathematics and physical science for aircraft, aircraft weight and balance, aircraft drawing and blueprint reading. Both theory and practical application to aircraft systems is taught. ADVISORY: Mathematics 205 Meets at Gavilan College Aviation Department, 490 Skylane Drive, Hollister Airport, Hollister. Basic hand tools required. Details at the first class meeting.

10534 L/L AV102 Connal D 14.00 7.5 MTWRF 0800A-1030A
08/13/08 - 12/19/08 Above class meets at the Hollister Airport.

AMT 110 Airframe Maintenance Technology

Transferable: CSU

Study of aircraft aerodynamics, rigging and assembly, aircraft sheet metal structures and welding technology. Also the study of cabin atmosphere systems, fuel systems, and line maintenance, level information on aircraft instruments. Each of these areas will be accompanied with appropriate laboratory time. Meets at Gavilan College Aviation Department, 490 Skylane Drive, Hollister Airport, Hollister. Basic hand tools required. Details at the first class meeting.

10557 L/L AV102 Hall C 10.00 3.5 MT 1030A-0330P
L/L AV102 Connal D 15.00 WRF 1030A-0330P
08/13/08 - 12/19/08 Above class meets at the Hollister Airport.

AMT 120 Aviation Powerplant Technology

Transferable: CSU

This course is part of the curriculum required by the Federal Aviation Administration to obtain certification as an aircraft powerplant maintenance technician. This certificate allows the rated technician to perform maintenance, preventive maintenance repairs and alterations to USA FAA certificated aircraft powerplants. This Section covers the theory and practical application of operation, overhaul practices, inspection, installation, testing and troubleshooting techniques covering the subject areas of reciprocating and turbine engines, ignition, induction, supercharging, cooling and exhaust systems. ADVISORY: Successful completion of AMT 101 and AMT 111. Basic hand tools required. Details at the first class meeting.

10537 L/L AV102 Flippen T 27.20 4.0 TWRF 0830A-0300P
08/13/08 - 12/19/08 Above class meets at the Hollister Airport.

AMT 123 Independent Study

Transferable: CSU

Designed to afford selected students specialized opportunities for exploring areas at the independent study level. The courses may involve extensive library work, research in the community, or special projects. May be repeated until six units of credit are accrued. This course has the option of a letter grade or pass/no pass. REQUIRED: The study outline prepared by the student and the instructor must be filed with the department and the dean. Meets at Gavilan College Aviation Department, 490 Skylane Drive, Hollister Airport, Hollister.

10539 Ind AV102 Flippen T 1.0
08/13/08 - 12/19/08 Above class meets at the Hollister Airport.

10540 Ind AV102 Flippen T 2.0
08/13/08 - 12/19/08 Above class meets at the Hollister Airport.

**Campus under construction
ROOM NUMBERS MAY CHANGE!**

Check room numbers online before your first class.

The Sky is the Limit!

at the **Gavilan
Aviation
Maintenance
Technology
Program**



Unlimited employment opportunities
Graduates can earn up to \$30/hour
Internships available

Accredited by the Federal Aviation Administration
Receive both Airframe and Powerplant Licenses in 4 semesters
Fast and easy commute to training program

For complete program information please contact the Aviation
Department at the Hollister Airport (831) 637-1151 or the
Technical and Public Services Division at Gavilan (408) 848-4719.

*We have now made it easier for you to find out what is
happening at Gavilan College.*

Gav Arts + Events

Art Dance Music Theater Sports Gym PE Events

Log on to <http://www.gavilan.edu/pio/GavArts.html> to see
what entertainment and events Gavilan has to offer!

CRN Type Room Instructor Hrs. Units Days Begin-End

AMT 190 Occupational Work Experience/Aviation

Transferable: CSU

College credit for learning experience obtained on the job in accordance with a training plan developed cooperatively between the employer, college and student. 75 hours per semester per unit or 60 hours per semester for unpaid experience. This is a pass/no pass course. May be taken for a maximum of 16 units of work experience units. REQUIRED: Declared vocational major. Concurrent in seven or more units (including CWE units, except for summer school. For summer school, enrollment in one other class is required). Minimum 2.00 G.P.A. Meets at Gavilan College Aviation Department, 490 Skylane Drive, Hollister Airport, Hollister.

Mandatory course orientation for the following classes will be conducted Tuesday evening, September 23rd from 5:30-6:30 pm in BU117, Wednesday, Sept. 24th or Thursday Sept. 25th, from 12-1 p.m. in SC 154N. Students need to attend one of the three meetings. Please contact Lynda Kerr, CWE Coordinator at (408) 846-4993 for more information.

10069	Wrk Ex	BU125	Kerr L		1.0		
10071	Wrk Ex	BU125	Kerr L		2.0		
10078	Wrk Ex	BU125	Kerr L		3.0		
10081	Wrk Ex	BU125	Kerr L		4.0		

BIOLOGICAL SCIENCE

BIO 1 General Biology

Transferable: CSU, UC; CSU-GE:B3, B2; IGETC:5B; GAV-GE:B2, B3; CAN:BIOL2, BIOL SEQ A

A general biology course with an emphasis on the structure and function of cells, cell respiration, photosynthesis, cell cycle, Mendelian and non-classical genetics, evolution and diversity of life. The course is required for students majoring in biology and/or its subcategories (e.g., plant or animal sciences). PREREQUISITE: Biological Science 10 with a grade of 'C' or better and Mathematics 233 with a grade of 'C' or better. ADVISORY: Chemistry 30A; eligible for English 250 and English 260.

10791	Lec	LS102	Morales R	3.20	4.0	TR	0230P-0350P
	Lab	LS102	Morales R	3.30		F	0810A-1115A

BIO 4 General Zoology

Transferable: CSU, UC; CSU-GE:B3, B2; IGETC:5B; GAV-GE:B2, B3; CAN:BIOL4, BIOL SEQ A

The classification, ecology, evolution and systems analysis of biological functions in major taxonomic groups of animals from Protists through to Chordata. PREREQUISITE: Mathematics 233 with a grade of 'C' or better. ADVISORY: Eligible for English 250 and English 260.

10792	Lec	LS102	Morales R	3.20	4.0	TR	0945A-1105A
	Lab	LS103	Morales R	3.30		M	0230P-0535P

BIO 7 Human Anatomy

Transferable: CSU, UC; CSU-GE:B2, B3; IGETC:5B; GAV-GE:B3, B2; CAN:BIOL10, BIOL SEQ B

A functional approach to the gross and microscopic structure of the major systems of the human body. Includes dissection in lab. A cadaver is observed in this course. PREREQUISITE: Biological Science 10 or 15 with a grade of credit or C or better. ADVISORY: Eligible for English 250, English 260 and Mathematics 205.

10793	L/L	LS103	McKenna M	8.60	4.0	TR	0945A-0150P
-------	-----	-------	-----------	------	-----	----	-------------

BIO 8 General Microbiology

Transferable: CSU, UC; CSU-GE: B2, B3; IGETC:5B; GAV-GE: B2, B3; CAN:BIOL14

An introduction to microbiology with an emphasis on bacteriology. Includes the study of morphology, physiology and classification of microorganisms, a survey of infectious disease, immunology and techniques for culture and control of microorganisms. This course is also listed as Allied Health 8. PREREQUISITE: Biological Science 10 or 15 with a grade of credit or C or better. ADVISORY: Chemistry 30A; eligible for English 250, English 260 and Mathematics 205.

10854	Lec	LS101	McKenna M	4.60	5.0	WF	0945A-1150A
							If you enroll in this class you must enroll in CRN 10856, 10857 or 10858.
10856	Lab	LS103	McKenna M	3.20	5.0	WF	0810A-0930A
							If you enroll in this class you must enroll in CRN 10854.
10857	Lab	LS103	McKenna M	3.20	5.0	WF	1250P-0210P
							If you enroll in this class you must enroll in CRN 10854.
10858	Lab	LS103	Smith M	3.20	5.0	TR	0430P-0550P
							If you enroll in this class you must enroll in CRN 10854.

CRN Type Room Instructor Hrs. Units Days Begin-End

BIO 9 Human Physiology

Transferable: CSU, UC; CSU-GE:B2, B3; IGETC:5B; GAV-GE:B2, B3; CAN:BIOL12, BIOL SEQ B

A study of the functions of the major organs and organ systems of the human body, emphasizing control at the cellular level, integration of systems and homeostasis of the human body. This course is also listed as Allied Health 9. PREREQUISITE: Biological Science 7 or 15 with a grade of credit or C or better. ADVISORY: Chemistry 30A; eligible for English 250, English 260 and Mathematics 205.

10957	Lec	LS103	TBA	4.30	5.0	M	0550P-0955P
	Lab	LS101	TBA	3.30		W	0600P-0905P

BIO 10 Principles of Biology

Transferable: CSU, UC; CSU-GE:B3, B2; IGETC:5B; GAV-GE:B2, B3

An introductory biology course covering functions at the cellular and organismal levels. Includes study of the basic principles of metabolism, heredity, evolution and ecology. Primarily for non-biological science majors. ADVISORY: Eligible for English 250, English 260 and Mathematics 205.

10859	Lec	PB3	TBA	3.20	4.0	TR	0810A-0930A
							If you enroll in this class you must enroll in CRN 10860 or 10861.
10860	Lab	LS102	TBA	2.30		M	0810A-1015A
							If you enroll in this class you must enroll in CRN 10859.
10861	Lab	LS102	TBA	2.30		W	0810A-1015A
							If you enroll in this class you must enroll in CRN 10859.
10863	Lec	SS214	TBA	3.20	4.0	MW	0230P-0350P
							If you enroll in this class you must enroll in CRN 10864, 10865, 10867, or 10868.
10864	Lab	LS102	TBA	2.30		M	1120A-0125P
							If you enroll in this class you must enroll in CRN 10863.
10865	Lab	LS102	TBA	2.30		W	1120A-0125P
							If you enroll in this class you must enroll in CRN 10863.
10867	Lab	LS102	TBA	2.30		W	0400P-0605P
							If you enroll in this class you must enroll in CRN 10863.
10868	Lab	LS102	TBA	2.30		M	0400P-0605P
							If you enroll in this class you must enroll in CRN 10863.
10794	L/L	LS102	Gemar A	4.60	4.0	MW	0630P-0835P

BIO 11 Nutrition

Transferable: CSU, UC; CSU-GE:E2; GAV-GE:E2, F; CAN:FCS2

This course is designed to meet the needs of the Allied Health student and the general education student alike. The major aim of this course is to help the student acquire relevant information about nutrition which they can use professionally and/or personally. The course will cover the practical aspects of normal nutrition, ways to promote sound eating habits throughout the life cycle, and physiological contribution nutrients make to body structure and function. This course is also listed as Allied Health 11. PREREQUISITE: Eligible for English 250 and English 260 ADVISORY: Chemistry 30A and Mathematics 205.

10515	Lec	LS106	Akrop M	3.30	3.0	T	1250P-0355P
10517	Lec	LS106	Akrop M	3.30	3.0	T	0400P-0705P

10519 Online N/A Akrop M 3.0
 This online class will be delivered entirely over the Internet. After enrolling, start the class by going to <http://www.gavilan.edu/disted>, and log into the system. Students who have not logged in by 5 pm on the 3rd day may be dropped from the class.

BIO 15 Survey of Human Anatomy and Physiology

Transferable: CSU, UC; CSU-GE:B3, B2; IGETC:5B; GAV-GE:B3, B2

An introductory study of the structure and function of the human body. Includes study at the cellular and organ system levels, emphasizing integration of systems. Note that a cadaver will be observed in this course. This course is also listed as Allied Health 15. ADVISORY: Biological Science 10, Eligible for English 250, English 260 and Mathematics 205. Course will include the viewing of a cadaver.

10876	Lec		Morales R		5.0		
	Lab	LS103	Morales R	3.30		W	0400P-0705P

This HYBRID section will meet Face-to-Face every Wednesday on campus for Lab and Online for Lecture throughout the week. An orientation to this class will be held the first lab meeting and anyone who does not attend this first lab session will be dropped from the class. It is highly recommended that students are computer/internet competent and keyboard skills and an e-mail account will be necessary to converse on-line and be successful in the class.

10884	L/L	LS103	Johnson B	8.00	5.0	TR	0600P-0940P
-------	-----	-------	-----------	------	-----	----	-------------

CRN Type Room Instructor Hrs. Units Days Begin-End

BIOTECHNOLOGY

BIOT 103 Biotechnology Lab Skills and Instrumentation

Transferable: CSU

Introduction to biotechnology laboratory skills. Techniques will include measuring, aseptic technique and transfer skills, preparation of buffers and other solutions, basic media preparation and dilutions, electrophoresis. Includes use and care of instruments such as microscope, spectrophotometer, centrifuge, pH meter, mechanical and micropipettes, autoclave, and electronic balance. Will also include keeping of a notebook, report writing and calculations. ADVISORY: Completion of any high school science course with a grade of 'C' or better; eligible for English 250; eligible for Math 205.

10795	L/L	LS102	TBA	8.60	4.0	TR	0530P-0935P
-------	-----	-------	-----	------	-----	----	-------------

Business Accounting: see Accounting

BUSINESS OFFICE TECHNOLOGY

BOT 112 Business Computations with Machines

Transferable: CSU

Self-paced course in the operation of the electronic printing calculator. This course provides theory and practice in business applications with emphasis on mathematical problem solving. This course has the option of a letter grade or pass/no pass. May be repeated three times for credit. ADVISORY: Eligible for Mathematics 402.

10411	Lab	BU110	Gaffney S	.5			
Orientation required. Schedule available in BU 110. Open entry-open exit.							

BOT 180 Medical Terminology for the Office

Transferable: CSU

This course introduces fundamentals of medical word building used in the health profession (prefixes, word roots, suffixes and abbreviations) as well as review of body systems, with emphasis on analysis, definition, spelling and pronunciation. This course had the option of a letter grade or pass/no pass. ADVISORY: Eligible for English 250 and English 260.

10413	Lec	HOL1	Hardcastle C	3.00	3.0	M	0945A-1240P
Above class meets at the Hollister Briggs site.							
10415	Lec	MHG4	Knapp D	3.00	3.0	R	0300P-0555P
Class meets at Morgan Hill Community site. ROP class.							

BOT 181 Medical Billing - MediSoft

Transferable: CSU

This course in computerized billing procedures for a medical office uses MediSoft software. Students will learn the patient billing features of this software and complete a capstone simulation giving them hands-on realistic medical front office practice. This course has the option of a letter grade or pass/no pass. May be repeated three times for credit. ADVISORY: Eligible for English 250. Some computer experience.

10418	L/L	BU110	Knapp D	3.30	2.0	W	0600P-0905P
ROP class.							

BOT 183 Medical Coding

Transferable: CSU

This course will introduce the student to the theory and procedure of coding for medical diagnoses, an increasingly essential and specialized healthcare communication system. The course is not a certification course. CPT coding is covered, with an overview of ICD-9 coding. This course has the option of a letter grade or pass/no pass. May be repeated three times for credit. ADVISORY: BOT 180.

10422	L/L	LS106	Hardcastle C	3.00	2.0	F	0945A-1240P
ROP class.							

Train for a Career in Biotechnology

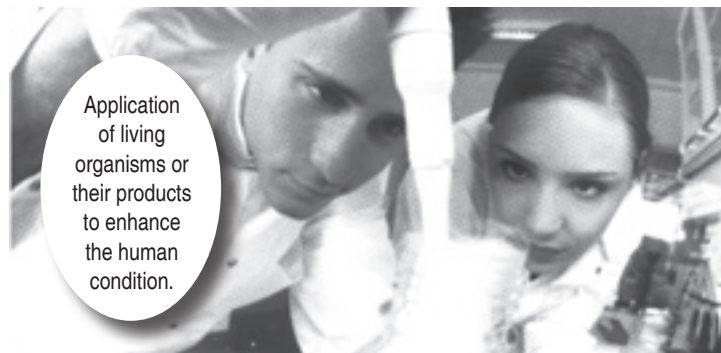

In addition to the biotechnology industry, jobs for lab technicians can be found in:

- ◆ Environmental testing
- ◆ Forensics
- ◆ Hospitals
- ◆ Plant pathology
- ◆ Research

This semester take

BIOT 103
Biotechnology Lab Skills



Certificate of Achievement in Biotechnology (17 units)

- BIOT 103 Biotechnology Lab Skills and Instrumentation (4 units)
- BIOT 104 Seminar in Biotechnology (1 unit)
- BIO 10 Principles of Biology (4 units)
- CHEM 30A Elementary Chemistry (4 units)
- CHEM 30B Elementary Organic and Biochemistry (4 units)

www.gavilan-sjbc.org

CRN Type Room Instructor Hrs. Units Days Begin-End

BOT 190 Occupational Work Experience/Business Office Technology

Transferable: CSU

College credit for learning experience obtained on the job in accordance with a training plan developed cooperatively between the employer, college and student. 75 hours per semester per unit or 60 hours per semester for unpaid experience. This is a pass/no pass course. May be taken for a maximum of 16 work experience units. REQUIRED: Declared vocational major. Concurrent enrollment in seven or more units (including CWE units, except for summer school. For summer school enrollment in one other class is required). Minimum 2.00 G.P.A.

Mandatory course orientation for the following classes will be conducted Tuesday evening, September 23rd from 5:30-6:30 pm in BU117, Wednesday, Sept. 24th or Thursday Sept. 25th, from 12-1 p.m. in SC 154N. Students need to attend one of the three meetings. Please contact Lynda Kerr, CWE Coordinator at (408) 846-4993 for more information.

10100	Wrk Ex	BU125	Kerr L				1.0
10102	Wrk Ex	BU125	Kerr L				2.0
10103	Wrk Ex	BU125	Kerr L				3.0
10105	Wrk Ex	BU125	Kerr L				4.0

CRN Type Room Instructor Hrs. Units Days Begin-End

BUSINESS, GENERAL

BUS 1 Fundamentals of Business

Transferable: CSU, UC; GAV-GE:D2

This course introduces students to business and the array of opportunities that it offers. The course will help students recognize careers that will be of interest to them with consideration of their own skills and aptitudes. Different facets of business will be covered and students will learn about establishing their own business. This course has the option of a letter grade or pass/no pass. Previously listed as GBUS 1. ADVISORY: Eligible for English 250 and English 260.

10426 Lec BU120 Robinson V 3.20 3.0 MW 1120A-1240P

10429 Lec HOL1 Ross Y 3.20 3.0 TR 1250P-0210P
Above class meets at the Hollister Briggs site.

10431 Lec MHG3 Kurtz S 3.30 3.0 W 0600P-0905P
Above class meets at Morgan Hill Community site.

BUS 14 Personal Finance

Transferable: CSU

This course is designed to assist individuals to analyze their financial affairs for lifelong decision making. Elements and concepts of financial planning and decision making in the areas of budgeting, taxes, borrowing, money management, insurance, investments, retirement, and estate planning will be examined. This course is also listed as ECON 14. This course has the option of a letter grade or pass/no pass. Previously listed as GBUS 14. ADVISORY: Math 400

10435 Lec HOL2 Ross Y 3.30 3.0 S 0800A-1105A
Above class meets at the Hollister Briggs site.

BUS 80 Business Law

Transferable: CSU, UC; CAN:BUS12

Introduction to the law applicable to business institutions and their operations; social forces and their effect upon the development of law; sources of law, agencies for enforcement, and court procedure and administration agencies. Substantive law, that law which includes rights and duties, will include contracts, agency employment relationships, torts and crimes. This course has the option of a letter grade or pass/no pass. Previously listed as GBUS 80. ADVISORY: Eligible for English 250 and English 260.

10441 Lec SS205 Banks S 3.30 3.0 T 0600P-0905P

Ceramics: see Art

CHEMISTRY

CHEM 1A General Chemistry

Transferable: CSU, UC; CSU-GE:B3, B1; IGETC:5A; GAV-GE:B3, B1; CAN:CHEM2, CHEM SEQ A

This is the first semester of a year-long general chemistry course designed for science, engineering and pre-professional majors. Topics include properties of matter, atomic structure, the Periodic Table, stoichiometry, elements and compounds, bonding, molecular structure, chemical reactions, states of matter, as well as the properties of gases and solutions. PREREQUISITE: Chemistry 30A with a grade of 'C' or better, or high school chemistry with a grade of 'B' or better completed within the last five years, and Mathematics 233 with a grade of 'C' or better. ADVISORY: Eligible for English 250 and English 260.

10895 Lec CH109 Clark D 3.20 5.0 MW 0945A-1105A
Lec CH109 Clark D 1.00 F 1030A-1120A
If you enroll in this class you must enroll in CRN 10896 or 10897.

10896 Lab CH101 Clark D 3.30 R 0945A-1250P
If you enroll in this class you must enroll in CRN 10895.

10897 Lab CH101 Clark D 3.30 R 0600P-0905P
If you enroll in this class you must enroll in CRN 10895.

CRN Type Room Instructor Hrs. Units Days Begin-End

CHEM 12A Organic Chemistry

Transferable: CSU, UC; CSU-GE:B3, B1; IGETC:5A; GAV-GE:B3, B1

This is the first semester of a year-long organic chemistry course designed for chemistry majors, pre-professional medical, biology, and science majors. Topics include nomenclature, stereochemistry, mechanisms, reactions and spectroscopic studies of organic compounds. Lecture and laboratory methods will focus on synthesis, isolation, purification, elucidation, and identification of organic structures, as well as instrumental methods and data interpretation. PREREQUISITE: Chemistry 1B

10796 Lec LS102 Clark D 3.20 5.0 TR 1250P-0210P
Lab CH101 Clark D 6.60 TR 0230P-0535P

CHEM 30A Elementary Chemistry

Transferable: CSU, UC; CSU-GE:B3, B1; IGETC:5A; GAV-GE:B3, B1; CAN:CHEM6, CHEM SEQ B

This is a first semester college chemistry course designed for majors preparing to take Chemistry 1A, nursing and allied health students, as well as general education. The course will cover the principles of chemistry including properties of matter, energy, atomic theory, the Periodic Table, stoichiometry, elements and compounds, the properties of bonding, molecular structure, chemical reactions, states of matter, acidity, solutions and gases, as well as an introductory to organic chemistry. ADVISORY: Mathematics 205; eligible for English 250 and English 260.

10905 Lec CH109 Clark D 3.20 4.0 MW 0810A-0930A
If you enroll in this class you must enroll in CRN 10906 or 10907.

10906 Lab CH101 Clark D 3.30 T 0945A-1250P
If you enroll in this class you must enroll in CRN 10905.

10907 Lab CH101 Clark D 3.30 T 0600P-0905P
If you enroll in this class you must enroll in CRN 10905.

CHILD DEVELOPMENT

CD 1 Principles and Philosophies of Early Childhood Education

Transferable: CSU

An overview of current educational theories and research, as well as an historical perspective on the development of early childhood education. Observations in schools are to be arranged. ADVISORY: Eligible for English 250 and English 260.

10149 Lec LS101 Clabaugh D 3.20 3.0 TR 0945A-1105A

10152 Lec MHG3 Segal M 3.30 3.0 T 0600P-0905P
Above class meets at Morgan Hill Community site.

CD 2 Early Child Development

Transferable: CSU, UC; CSU-GE:E; IGETC:4I; GAV-GE:D2

A systematic study of the child from prenatal life through the preschool years. The course integrates the basic concepts of physical, cognitive and psychosocial development at each major stage of life during this period. This course is also listed as PSYC 2. This course has the option of a letter grade or pass/no pass. ADVISORY: Eligible for English 250 and English 260; transfer students consult with advisor.

10154 Lec MHG4 Bumgarner M 3.20 3.0 MW 0945A-1105A
Above class meets at Morgan Hill Community site.

10159 Lec HOL2 Muscari D 3.30 3.0 W 0600P-0905P
Above class meets at the Hollister Briggs site.

CD 3 Child Growth and Development During the School Years

Transferable: CSU, UC; CSU-GE:E; IGETC:4I; GAV-GE:D2

Continuation of the study of the principles of child development with emphasis on children from six years through adolescence. Includes developmental theories and topics relevant to these ages. This course is also listed as PSYC 3. This course has the option of a letter grade or pass/no pass. ADVISORY: Eligible for English 250 and English 260; Child Development 2; transfer students consult with advisor.

10972 Online N/A Bumgarner M 3.0



This online class will be delivered entirely over the Internet. After enrolling, start the class by going to <http://www.gavilan.edu/disted>, and log into the system. Students who have not logged in by 5 pm on the 3rd day may be dropped from the class.

Classroom Locations: Refer to "How to Use This Schedule" on page 6.

CRN	Type	Room	Instructor	Hrs.	Units	Days	Begin-End
-----	------	------	------------	------	-------	------	-----------

CD 5 Child/Family and Community

Transferable: CSU

Patterns of child-rearing in contemporary society. Interaction of family, school and community. Significance of personal and social values in family life and community action. Individual and social resources for family life including health, welfare and improving child development. ADVISORY: Eligible for English 250 and English 260.

10166	Lec	LS106	TBA	3.30	3.0	M	0600P-0905P
-------	-----	-------	-----	------	-----	---	-------------

CD 7 Cultural Context of Childhood

Transferable: CSU; CSU-GE:D7; GAV-GE:F

This course examines cultural influences on child-rearing practices, family values, and human development. Perspectives from the social sciences will be used to explore what is common to all Homo sapiens and what is specific to the culture of the U.S. Students will explore their own personal assumptions and attitudes towards diversity, and practice implementing non-stereotypical, developmentally appropriate, anti-bias activities, interactions and environments in order to respond to and intervene against prejudice among children. This course is also listed as PSYC 7 and ANTH 9. ADVISORY: Eligible for English 250 and English 260.

10168	Lec	MHG4	Bumgarner M	3.20	3.0	MW	1120A-1240P
Above class meets at Morgan Hill Community site.							

CD 8A American Education in a Changing World

Transferable: CSU

This course provides an overview of education in the United States. It examines the issues, problems, and solutions to teaching in a pluralistic society by viewing schools as social institutions that reflect the values and dynamics of a society. It focuses on the history, politics, theories and approaches to teaching culturally and linguistically diverse children and analyzes career opportunities and new directions in education. For students who wish to expand their knowledge of education in America, and those who wish to explore careers in teaching. This course includes a Service Learning component that will encourage students to explore and apply concepts from the class. This course has the option of a letter grade or pass/no pass.

10975	Lec	MHG11	Malaspina B	3.30	3.0	R	0600P-0905P
Above class meets at Morgan Hill Community site.							

CD 9 Child Health/Nutrition and Safety

Transferable: CSU

Health, Safety and Nutrition promotion in young children is studied. Course covers illness and accident prevention, quality food programs and community resources for health, safety and nutrition. Students will learn to promote making healthier choices by teaching hygiene, safety practices and nutritious food choices. Poison prevention, fire and earthquake safety and emergency preparedness is covered. Students learn to design lesson plans to teach children and their parents to make healthy, safe and nutritious choices. This course has the option of a letter grade or pass/no pass. ADVISORY: Eligible for English 250 and English 260.

10172	Lec	LS106	Clabaugh D	3.40	3.0	TR	1120A-1245P
-------	-----	-------	------------	------	-----	----	-------------

CD 11A Administration of Programs for Young Children

Transferable: CSU

The principles and practices of the organization and administration of facilities for preschool aged children. Areas covered include organizational structure, budgeting, personnel policies and practices, records, statistics, reporting, relationship with community resources, regulatory agencies, and parents. ADVISORY: Child Development 1 and 2.

10173	Lec	LS106	Alonzo S	3.30	3.0	W	0600P-0905P
-------	-----	-------	----------	------	-----	---	-------------

CD 13 Infant and Toddler Development and Care

Transferable: CSU

Students will study the developmental stages of growth specific to infants and toddlers and learn how to foster positive techniques for nurturing infants and toddlers in group settings. Students will study the RIE philosophy and learn how to observe children in child care and home day care settings. This course has the option of a letter grade or pass/no pass. ADVISORY: Eligible for English 250 and English 260. Child Development 2.

10174	Lec	PB3	Alonzo S	3.30	3.0	M	0600P-0905P
-------	-----	-----	----------	------	-----	---	-------------



Begin your year of Organic or General Chemistry here at Gavilan College!

CHEM 1A General Chemistry

The first semester of a year-long General Chemistry course designed for science, engineering and pre-professional majors.

Chem 1A is a prerequisite for Chem 1B (taught in the spring semester)

CHEM 12A Organic Chemistry

The first semester of a year-long Organic Chemistry course designed for science, engineering and pre-professional majors.

Chem 12A is a prerequisite for Chem 12B (taught in the spring semester)

The above two courses satisfy Science major prerequisites and the Physical Science requirement for transfer to both the California State University and the University of California systems.

CHEM 30A Elementary Chemistry

The first semester chemistry course designed for majors preparing to take Chemistry 1A, nursing and allied health students, as well as general education.

Chem 30A is a prerequisite for Chem 30B (taught in the spring semester)

CHEM 30A satisfies the Physical Science requirement for transfer to both the California State University and the University of California systems. It may satisfy Science major prerequisites. See a counselor.

Instructor for all courses: Dr. Dale Clark

All of the above courses satisfy Science major prerequisites and the Physical Science requirement for transfer to both the California State University and the University of California systems.

ECON/BUS 14 Personal Finance

3 Units

Learn to analyze your financial affairs for lifelong decision making!



budgets
taxes
borrowing
money management
insurance
investments
retirement
estate planning

CRN Type Room Instructor Hrs. Units Days Begin-End

CD 14A Working with School Age Children

Transferable: CSU

Students will learn the developmental characteristics of school aged children, issues relating to before and after school programs for children from kindergarten to grade eight, and specific details of administering and leading such a program. Other topics include recreation versus academic enrichment, staffing requirements, age groupings, program content, and community resources. This course has the option of a letter grade or pass/no pass. ADVISORY: Eligible for English 250 and 260. Child Development 3.

10177	Lec	PB13	Bumgarner M	3.30	3.0	T	0600P-0905P
-------	-----	------	-------------	------	-----	---	-------------

CD 20 Children's Language and Literature

Transferable: CSU

A developmental view of children's language and literacy learning in a framework of children's literature. Students will be presented with steps in children's literacy learning in order to help them organize classrooms and plan activities to support the growth of writing and reading. Students will study historical trends in children's literature and participate in practical experiences and activities that use a wide range of techniques and materials for advancing language comprehension and usage. This course has the option of a letter grade or pass/no pass. ADVISORY: Eligible for English 250 and English 260.

10179	Lec	MHG4	TBA	3.30	3.0	W	0600P-0905P
Above class meets at Morgan Hill Community site.							

CD 23 Independent Study

Transferable: CSU

Designed to afford selected students specialized opportunities for exploring areas at the independent study level. The courses may involve extensive library work, research in the community, or special projects. May be repeated three times or until six units of credit are accrued. This course has the option of a letter grade or pass/no pass. REQUIRED: The study outline prepared by the student and the instructor must be approved by the department and the dean.

10181	Ind	SS202B	Bumgarner M	1.0			
10976	Ind	SS202B	Bumgarner M	2.0			

CD 25A Art Methods

Transferable: CSU; CSU-GE:C1; GAV-GE:C1

Art methods and learning theory for those planning to work with preschool, elementary and secondary students. Includes art therapy as well as gifted and special learner projects. Two dimensional work in printing, painting, drawing, collage. Also listed as ART 25A.

10189	L/L	HOL1	McGinnis R	4.30	3.0	F	0400P-0805P
	ARR		TBA	2.00			
Above class meets at the Hollister Briggs site. This class requires an additional 2 arranged hours per week.							

CD 25B Art Methods

Transferable: CSU; GAV-GE:C1

Art methods, creativity and learning theory for those planning to work with preschool, elementary, and secondary school students. Includes art therapy as well as gifted and special learner projects. Three dimensional work in sculpture, bas relief, mobiles, paper mache', plaster, and various 3-D materials. Also listed as ART 25B.

10191	L/L	HOL1	McGinnis R	4.30	3.0	F	0400P-0805P
	ARR		TBA	2.00			
Above class meets at the Hollister Briggs site. This class requires an additional 2 arranged hours per week.							

CD 30A Teaching Practices and Techniques

Transferable: CSU

Designing, developing and implementing contemporary curriculum and instructional methods for early childhood education. Completion of 30A and 30B satisfies the associate degree requirement for student teaching. ADVISORY: Completion of Child Development 1 and 2 with a "C" or higher. Concurrent enrollment in CD 190.

10193	Lec	PB13	Segal M	3.30	3.0	M	0600P-0905P
In order to obtain Field Work Credit for the Occupational Work Experience placement, students must enroll in CD30A or 30B.							

CRN Type Room Instructor Hrs. Units Days Begin-End



CD 35 Establishing Positive Behavior in the Classroom

Transferable: CSU

Introduces the student to realistic and effective strategies for guiding all young children's behavior. This course demonstrates best practices for establishing and maintaining age and developmentally- appropriate productive behaviors among all children in a classroom setting. Course topics include environmental, developmental and special needs sources of maladaptive and challenging behaviors, guidelines for selecting and implementing strategies for positive behavior change for all children, and developing healthy communication strategies with families, program staff and children. ADVISORY: Eligible for English 1A.

10195	Lec	PB3	Clabaugh D	3.30	3.0	T	0600P-0905P
-------	-----	-----	------------	------	-----	---	-------------

CD 190 Occupational Work Experience/Child Development

Transferable: CSU

College credit for learning experience obtained on the job in accordance with a training plan developed cooperatively between the employer, college and student. 75 hours per semester per unit or 60 hours per semester for unpaid experience. This is a pass/no pass course. May be taken for a maximum of 16 work experience units. REQUIRED: Declared vocational major. Concurrent enrollment in seven or more units (including CWE units, except for summer school. For summer school, enrollment in one other class is required). Minimum 2.00 G.P.A.

For all four following classes: In order to obtain Field Work Credit for the Occupational Work Experience placement, students must enroll in CD30A or 30B.

10196	Wrk Ex	CD100	Segal M	1.0			
10197	Wrk Ex	CD100	Segal M	2.0			
10198	Wrk Ex	CD100	Segal M	3.0			
10200	Wrk Ex	CD100	Segal M	4.0			

COMMUNICATION STUDIES

CMUN 1A Introduction to Public Speaking

Transferable: CSU, UC; CSU-GE:A1; IGETC:1C; GAV-GE:A1; CAN:SPCH4

Basic principles of effective human communication and their function in contemporary public settings; emphasis is on the speech to inform, with special consideration given to fundamental communication skills, including organization, reasoning, explanation and listening. ADVISORY: Eligible for English 250 and English 260.

10600	Lec	PB1	Giacalone S	3.20	3.0	TR	0810A-0930A
10602	Lec	PB1	Besson D	3.20	3.0	TR	1120A-1240P
10603	Lec	PB1	Besson D	3.20	3.0	TR	1250P-0210P
10604	Lec	PB1	Giacalone S	3.00	3.0	W	0235P-0535P
10605	Lec	MHG12	Ehrler D	3.30	3.0	M	0600P-0905P
Above class meets at Morgan Hill Community site.							
10607	Lec	HOL2	Andrade A	3.30	3.0	R	0600P-0905P
Above class meets at the Hollister Briggs site.							

CMUN 2 Oral Reading

Transferable: CSU, UC; CSU-GE:C1; GAV-GE:C1

An introduction to the analysis, preparation and dramatic reading of literature, including classical and contemporary prose, poetry and drama. Students will prepare, analyze and orally present and interpret great works of drama and literature for an audience. This course is also listed as THEA 4. ADVISORY: Eligible for English 250 and English 260.

10608	Lec	TH125	Lawton-Haehl J	3.20	3.0	TR	1120A-1240P
-------	-----	-------	----------------	------	-----	----	-------------

CMUN 4 Intercultural Communication

Transferable: CSU, UC; CSU-GE:D7, D3; IGETC:4G; GAV-GE: D2, F

This course will explore the dynamics of communication as it applies to people from different cultures. Course content focuses on the application of theory and research to intercultural communication contexts. Increasing the awareness and understanding of diversity, the perception process, culture, verbal and non-verbal communication and the obstacles that prevent one from becoming a competent intercultural communicator will be examined.

10610	Lec	PB1	Giacalone S	3.20	3.0	MW	0945A-1105A
-------	-----	-----	-------------	------	-----	----	-------------

Classroom Locations: Refer to "How to Use This Schedule" on page 6.

CRN Type Room Instructor Hrs. Units Days Begin-End

CMUN 5 Fundamentals of Communication Studies

Transferable: CSU, UC; CSU-GE:A1; IGETC:1C; GAV-GE:A1
 This course provides instruction and application of theory and practice in various communication contexts including the self concept, interpersonal, interviewing skills, small group dynamics, and public speaking. Emphasis is placed on analytical and organizational skills, listening, nonverbal and verbal communication, and public speaking communication methodology. **ADVISORY:** English 250 and English 260.

10620	Lec	HOL2	Waddell E	3.20	3.0	MW	0810A-0930A
Above class meets at the Hollister Briggs site.							

CMUN 8 Interpersonal Communication

Transferable: CSU, UC; CSU-GE:A1; IGETC:1C; GAV-GE:A1
 This course studies the communication process in an interpersonal (dyadic) setting. This class will explore the ways in which we can improve our communication with others. Verbal and nonverbal messages, self-concept, cultural differences, gender differences, perception, listening and conflict management will be explored.

10621	Lec	PB1	Besson D	3.20	3.0	MW	1120A-1240P
10622	Lec	PB1	Besson D	3.20	3.0	MW	1250P-0210P
10623	Lec	PB1	Waddell E	3.30	3.0	T	0600P-0905P

CMUN 10 Small Group Communication

Transferable: CSU, UC; CSU-GE:A1; IGETC:1C; GAV-GE:A1; CAN:SPCH10
 An introductory course that develops basic individual reasoning skills, insights and experiences in information-sharing, interacting, decision-making, problem-solving, resolution of disputes and other issues central to group processes. **ADVISORY:** Eligible for English 250 and English 260.

10626	Lec	PB1	Giacalone S	3.20	3.0	MW	0810A-0930A
This service learning course section involves community work.							
10627	Lec	PB1	Giacalone S	3.20	3.0	TR	0945A-1105A
This service learning course section involves community work.							
10625	Lec	PB1	Besson D	3.30	3.0	T	0230P-0535P
This service learning course section involves community work.							
10628	Lec	HOL2	Waddell E	3.20	3.0	MW	0945A-1105A
Above class meets at the Hollister Briggs site.							
10632	Lec	PB1	Cowan D	3.30	3.0	M	0230P-0535P
10631	Lec	MHG12	Cowan D	3.30	3.0	W	0600P-0905P
Above class meets at Morgan Hill Community site.							

CMUN 129 Presentation Graphics - MS Powerpoint

Transferable: CSU
 This introductory course in presentation graphics will use Microsoft Office's "PowerPoint" software to create a computerized presentation with text and objects. This course has the option of a letter grade or pass/no pass. May be repeated three times for credit. This course is also listed as CSIS 129. **ADVISORY:** CSIS 126 or word processing skills in the Windows environment.

10902	Lec	HOL3	Bryson M	4.60	1.0	MW	1120A-0125P
11/24/08 - 12/08/08 Above class meets at the Hollister Briggs site.							
10990	Lec	BU111	Venable E	2.00	1.0	F	1200P-0200P
10/03/08 - 12/12/08							

Computer Art: see ART 48A/B, CSIS or Digital Media

APPLY & REGISTER Online

Go to www.gavilan.edu and click on the Self-Service Banner icon.



Come on a voyage of self-discovery and become more culturally fluent.

Take... **CMUN 4 Intercultural Communication**

- ☞ Learn about people from different cultures.
- ☞ Increase your awareness and understanding of diversity.
- ☞ Study verbal and nonverbal communication.
- ☞ Become a competent communicator in an intercultural society.

CMUN 4 satisfies the Social Science requirement for the Gavilan AA/AS Degree and for transfer to UC and CSU.

Expand your horizons!

Take ... **CMUN 5 Fundamentals of Communication Studies**



Learn about various topics in the communication studies field:

- ▶ The self concept
- ▶ Interpersonal communication
- ▶ Interviewing skills
- ▶ Small group dynamics
- ▶ Public speaking

Satisfies the Social Science requirement for the AA/AS Degree and for transfer to CSU. Also satisfies the Oral Communications requirement for the AA/AS Degree and CSU.

Earn a Certificate of Achievement in Communication Studies

You're only four classes away. Get started today!

Complete 12 units. Classes applicable:

- CMUN 1A
- CMUN 2
- CMUN 4
- CMUN 5
- CMUN 8
- CMUN 10
- CMUN 11
- CMUN 129



Contact Denise Besson-Silvia at 408-848-4831 for further information.

CMUN 8 Interpersonal Communication

Study the ways in which we can improve our communication with others. Verbal and nonverbal messages, self-concept, cultural differences, gender differences, perception, listening and conflict management are explored.



Fulfills CSU and UC Oral Communication transfer requirements



The people of old had their own signals. Here's one that has meant "Attention" through all ages.

CRN Type Room Instructor Hrs. Units Days Begin-End

COMPUTER GRAPHICS AND DESIGN

CGD 2 2D/3D Technical Computer Graphics I

Transferable: CSU

Introduction and foundation to 2D and 3D visualization and manipulation using modeling, rendering, and animation processes. Emphasis is on individual students developing a personal style of problem solving and designing for a variety of design fields. Students work on cooperative group projects or individual assignments. This is an open entry/exit class and may be repeated once. May be repeated once for credit. This course has the option of a letter grade or pass/no pass. ADVISORY: LIB 3 and MATH 404G. Computer lab work can be done both in lab and off-site.

10203 L/L LI126 TBA 3.20 4.0 TR 1120A-1240P

CGD 4 2D/3D Technical Computer Graphics II

Transferable: CSU

Intermediate to complex 2D/3D modeling of geometric objects including working drawings, rendering and animation activities. This class allows personal student development in imagination and inventive problem solving that can be related to various creative design fields. Students work in individual and cooperative group projects. This is an open entry/exit course. ADVISORY: Completion of CGD 2 with a grade of C or better. Computer lab work can be done both in lab and off-site.

10987 L/L LI126 TBA 2.80 4.0 TR 0220P-0330P

CGD 6 Advanced Technical Computer Graphics

Transferable: CSU

Computer design in precision manufacturing. Applied geometry, mathematics for layout, and tolerancing. Advanced design processes and documentation for the designer. Students may concurrently enroll in CGD 110. An open entry/exit course. ADVISORY: Eligible for English 250, 260 and Mathematics 233. Computer lab work can be done both in lab and off-site.

10988 L/L LI126 TBA 2.80 4.0 TR 0220P-0330P

CGD 110 Computer Graphics Lab

Transferable: CSU

Structured for students concurrently enrolled in computer graphics and art classes. Provides supervised practice and individualized computer assisted learning on software applications and techniques commonly found in the computer graphic design field. This is an open entry/exit class and may be repeated three times. This course has the option of a letter grade or pass/no pass. ADVISORY: Concurrent enrollment in corresponding computer graphic and design classes. Computer lab work can be done both in lab and off-site.

10242 L/L LI126 TBA 1.0 Open entry - open exit.
 10244 L/L LI126 TBA 2.0 Open entry-open exit.
 10246 L/L LI126 TBA 3.0 Open entry-open exit.
 10247 L/L LI126 TBA 4.0 Open entry-open exit.

CGD 190 Occupational Work Experience/Computer Graphics & Design

Transferable: CSU

College credit for learning experience obtained on the job in accordance with a training plan developed cooperatively between the employer, college and student. 75 hours per semester per unit or 60 hours per semester for unpaid experience. This is a pass/no pass course. May be taken for a maximum of 16 work experience units. REQUIRED: Declared vocational major. Concurrent enrollment in seven or more units (including CWE units, except for summer school. For summer school enrollment in one other class is required). Minimum 2.0 G.P.A. Computer lab work can be done both in lab and off-site.

Mandatory course orientation for the following classes will be conducted Tuesday evening, September 23rd from 5:30-6:30 pm in BU117, Wednesday, Sept. 24th or Thursday Sept. 25th, from 12-1 p.m. in SC 154N. Students need to attend one of the three meetings. Please contact Lynda Kerr, CWE Coordinator at (408) 846-4993 for more information.

10114 Wrk Ex BU125 Kerr L 1.0
 10117 Wrk Ex BU125 Kerr L 2.0
 10118 Wrk Ex BU125 Kerr L 3.0
 10119 Wrk Ex BU125 Kerr L 4.0

CRN Type Room Instructor Hrs. Units Days Begin-End

COMPUTER SCIENCE & INFORMATION SYSTEMS

CSIS 1 Computer Literacy - MS Office

Transferable: CSU, UC; GAV-GE:E2; CAN:CSCI2

An introduction to terminology, design, operation for the novice user. Student will gain experience using the Internet for searches and email. They will complete projects using various software including word processing, spreadsheets, database, presentation graphics, and integration. This course has the option of a letter grade or pass/no pass. ADVISORY: Eligible for English 250 and English 260; completion of CSIS 122.

10442 Lec BU111 Gaffney S 4.60 2.0 MW 0900A-1105A
 09/03/08 - 10/20/08

10443 Lec BU111 Gaffney S 4.60 2.0 MW 0900A-1105A
 10/22/08 - 12/10/08

10444 Lec HOL3 Bryson M 4.60 2.0 MW 1120A-0125P
 09/10/08 - 11/03/08 Above class meets at the Hollister Briggs site.

10445 Lec GHS-D1 Conrey J 3.00 2.0 T 0330P-0630P
 9/09/08 - 11/25/08 Above class meets at Gilroy High School, 750 West Tenth St, Gilroy.

10446 Lec HOL3 Thompson F 3.30 2.0 R 0600P-0905P
 09/18/08 - 12/11/08 Above class meets at the Hollister Briggs site.

10447 Lec BU110 Gaffney S 3.30 2.0 T 0600P-0905P
 09/30/08 - 12/16/08 Short-term classes meet on specified dates.

CSIS 2 Computers in Business - MS Office

Transferable: CSU; GAV-GE:E2; CAN:BUS6

Introduction to computerized business data processing, information management systems, computer hardware, office automation, telecommunications, computer languages, systems analysis and design; hands on experience with common business software packages including word processing, spreadsheets, data base management, presentation graphics as well as systems software and Internet applications. This course has the option of a letter grade or pass/no pass. ADVISORY: Eligible for Mathematics 233, English 260 and English 250, and CSIS 122

10448 L/L BU111 Venable E 1.60 4.0 T 0945A-1105A
 L/L ONLINE Venable E 3.00

 This class requires one additional arranged hour per week and three hours online per week.

10452 L/L BU111 Venable E 1.60 4.0 F 0945A-1105A
 L/L ONLINE Venable E

 This class requires one additional arranged hour per week and three hours online per week.

CSIS 2L Computers in Business Lab - MS Office

Transferable: CSU

Computer Lab emphasizing business application in Microsoft Word, Excel, Access, Power Point and Integration. Internet searches are included. This course has the option of a letter grade or pass/no pass. Since supervised repetition and practice enhance skills/proficiencies. This course may be repeated once for credit.

10453 Lab BU111 Bryson M 1.60 1.0 T 0945A-1105A
 This class requires one additional arranged hour per week.

10460 Lab BU111 Bryson M 1.60 1.0 F 0945A-1105A
 This class requires one additional arranged hour per week.

10984 Lab BU111 Thompson F 3.30 1.0 M 0600P-0905P

CSIS 3 Research Skills

Transferable: CSU

Research and evaluation skills using the Internet and other electronic resources, as well as traditional printed materials. Also listed as LIB 3. This course has the option of a letter grade or pass/no pass. May be repeated once for credit. ADVISORY: Eligible for English 250 and 260.

10038 Online N/A Meader S 2.0
 10/14/08 - 12/08/08 This online class will be delivered entirely over the Internet. After enrolling, start the class by going to <http://www.gavilan.edu/disted>, and log into the system. Students who have not logged in by 5 pm on the 3rd day may be dropped from the class.

CRN Type Room Instructor Hrs. Units Days Begin-End

CSIS 5 C++ Scientific Programming

Transferable: CSU, UC; CAN:CSCI4

An introduction to computer problem solving and programming using the C++ language for science and engineering majors. Students will write programs for a variety of scientific and mathematical applications. This course has the option of a letter grade or pass/no pass.

PREREQUISITE: Mathematics 1A ADVISORY: Completion of CSIS 10.

10926 L/L LI126 Van Tassel D 4.00 3.0 MW 0945A-1135A

10927 Online N/A Van Tassel D 3.0

 This online class will be delivered entirely over the Internet. After enrolling, start the class by going to <http://www.gavilan.edu/disted>, and log into the system. Students who have not logged in by 5 pm on the 3rd day may be dropped from the class.

CSIS 6 Web Page Authoring I

Transferable: CSU; GAV-GE:E2

An introduction to using Hypertext Mark-Up Language (HTML) and Extensible HTML (XHTML) to create web pages which can be uploaded and displayed on the World Wide Web. Students will use HTML/XHTML to create web pages with text in various sizes and colors, links to other sites, background color or patterns, graphics, tables and mailto links. Principles of design and color as they apply to screen presentations will be included. This course has the option of a letter grade or pass/no pass. May be repeated three times for credit. Also listed as LIB 6 and DM 6. ADVISORY: CSIS 1 or CSIS 2 or CSIS 3/LIB 3 advised.

10503 Lec LI126 Littig A 4.60 2.0 TR 0900A-1105A
09/04/08 - 10/21/08

10470 Online N/A Howell J 2.0

 10/20/08 - 12/14/08 This online class will be delivered entirely over the Internet. After enrolling, start the class by going to <http://www.gavilan.edu/disted>, and log into the system. Students who have not logged in by 5 pm on the 3rd day may be dropped from the class.

10509 Online N/A Venable E 2.0

 09/29/08 - 11/23/08 This online class will be delivered entirely over the Internet. After enrolling, start the class by going to <http://www.gavilan.edu/disted>, and log into the system. Students who have not logged in by 5 pm on the 3rd day may be dropped from the class.

CSIS 8 Introduction to the Internet

Transferable: CSU; GAV-GE:E2

This course will provide students the opportunity to learn to use the Internet and the World Wide Web. Topics to be covered include history of the Internet and development of the WWW, web browsers, search engines, tools to develop web pages, how to get connected and local Internet providers. This is a pass/no pass course. May be repeated three times for credit. ADVISORY: CSIS 124

10598 Online N/A Venable E 1.0

 09/04/08 - 10/29/08 This online class will be delivered entirely over the Internet. After enrolling, start the class by going to <http://www.gavilan.edu/disted>, and log into the system. Students who have not logged in by 5 pm on the 3rd day may be dropped from the class.

10599 Online N/A Venable E 1.0

 10/29/08 - 12/21/08 This online class will be delivered entirely over the Internet. After enrolling, start the class by going to <http://www.gavilan.edu/disted>, and log into the system. Students who have not logged in by 5 pm on the 3rd day may be dropped from the class.

CSIS 10 BASIC Programming

Transferable: CSU, UC

This course is an introduction to programming using BASIC. No previous programming background is assumed. This is a good class for those new to programming and recommended for non-programmers that want to take other programming classes. This course has the option of a letter grade or pass/no pass. ADVISORY: CSIS 1 or CSIS 2 or equivalent experience.

10601 Lec LI126 Littig A 4.60 2.0 TR 0900A-1105A
10/23/08 - 12/11/08

GRADUATION INFORMATION



Call 408-848-4737 for details about the graduation process.

The deadline for filling out a petition for graduation for fall is Monday, October 13.

Admissions & Records

APPLY & REGISTER ONLINE ...

Go to www.gavilan.edu and click on the Self-Service Banner icon.

Day of Beauty

for Men & Women

Includes:

- ✓ Hair cut & style
 - ✓ Deep conditioning
 - ✓ Scalp treatment
 - ✓ Manicure
 - ✓ Facial
 - ✓ Eyebrow arch
 - ✓ Makeup
- no substitutions*

only **\$30**

w/o coupon - \$35

DISCOUNTS

Senior Citizens: 20% daily

Staff/Students: 10% daily

Discounts not applicable to DAILY SPECIALS, Special perms or any service under \$6.00

Spring/Fall hours

Wed.-Fri. 10:00 am - 2:30 pm

Summer hours

Tu.-Th. 10:30 am - 3:30 pm

DAILY SPECIALS

Wednesday:

Hair Cut ONLY - \$5.50

Hair Cut & Style - \$10

Thursday/Friday:

All Basic Perms - 20% off

Plain Manicure & Pedicure - \$11

Wednesday/Friday:

Hair Color - 20% off

All work performed by students supervised by instructors. Discounts not applicable to daily specials, special color, special perms or any service under \$6. Not valid with any other discounts.

For appointments call 408-842-5055

What is a CRN?

CRN stands for Course Reference Number. This is the number (used to be called section) that you will use to register for your classes.

CRN Type Room Instructor Hrs. Units Days Begin-End

CSIS 24 Java Programming I

Transferable: CSU, UC

Introduction to Java programming. Includes learning the Java environment, using and creating Java applets, and writing stand-alone applications. Covers the Java environment, object-oriented programming, language basics, classes, interfaces, packages, threads, and exceptions. This course has the option of a letter grade or pass/no pass. ADVISORY: CSIS 45 C++ Programming or equivalent programming experience.

10606 Online N/A Van Tassel D 4.0
 This online class will be delivered entirely over the Internet. After enrolling, start the class by going to <http://www.gavilan.edu/disted>, and log into the system. Students who have not logged in by 5 pm on the 3rd day may be dropped from the class.

10609 L/L MHG8 Van Tassel D 4.00 4.0 M 0600P-0950P
 Above class meets at Morgan Hill Community site.

 **CSIS 42 Python Programming**

Transferable: CSU

Introduction to the interpreted language called Python. Study and create programs that perform various tasks, including text and file manipulation, internet scripting, data structures, testing, and practical problem solving with examples. Covers object oriented programming and the Python Standard Library.

10938 Online N/A Howell P 4.0
 This online class will be delivered entirely over the Internet. After enrolling, start the class by going to <http://www.gavilan.edu/disted>, and log into the system. Students who have not logged in by 5 pm on the 3rd day may be dropped from the class.

CSIS 43 C Programming

Transferable: CSU, UC

This course introduces computer programming using the C programming language. Topics include variable and constant declarations, arithmetic operations, selection, input/output operations, repetition, functions and recursion, arrays, pointers, and other related topics. This course has the option of a letter grade or pass/no pass. ADVISORY: CSIS 10 BASIC Programming, or other programming experience.

10611 Online N/A Van Tassel D 4.0
 This online class will be delivered entirely over the Internet. After enrolling, start the class by going to <http://www.gavilan.edu/disted>, and log into the system. Students who have not logged in by 5 pm on the 3rd day may be dropped from the class.

10935 L/L LI126 Van Tassel D 4.00 4.0 MW 0945A-1135A

CSIS 45 C++ Programming I

Transferable: CSU, UC; GAV-GE:E2; CAN:CSCI18

An introduction to the concepts and methods of computer programming using C++. Students will be introduced to procedural and object-oriented programming design methodology. Topics covered include variable and constant declarations, selection statements, repetition, functions and recursion, arrays, strings, pointers, and an introduction to classes and objects. This course will prepare students for the Programming II class. This course has the option of a letter grade or pass/no pass. ADVISORY: CSIS 10 or equivalent. Math 205 (Elementary Algebra)

10612 Online N/A Van Tassel D 4.0
 This online class will be delivered entirely over the Internet. After enrolling, start the class by going to <http://www.gavilan.edu/disted>, and log into the system. Students who have not logged in by 5 pm on the 3rd day may be dropped from the class.

10613 L/L LI126 Van Tassel D 4.00 2.0 MW 0945A-1135A

CSIS 49 UNIX/Linux Shell Programming

Transferable: CSU, UC

A beginning course in UNIX/Linux shell programming using different commands including awk, sed, and Perl. The course will cover theory and concepts including interpretation of different quote characters, shell variables, decision-making commands, and looping mechanism. This course has the option of a letter grade or pass/no pass. ADVISORY: CSIS 48

10929 L/L MHG8 Van Tassel D 4.00 4.0 T 0600P-0950P
 Above class meets at Morgan Hill Community site.

10930 Online N/A Van Tassel D 4.0
 This online class will be delivered entirely over the Internet. After enrolling, start the class by going to <http://www.gavilan.edu/disted>, and log into the system. Students who have not logged in by 5 pm on the 3rd day may be dropped from the class.

CRN Type Room Instructor Hrs. Units Days Begin-End

CSIS 54 Perl Programming

Transferable: CSU, UC

Introduction to the interpreted language called PERL, the Practical Extraction and Report Language. Writing of programs that perform various tasks, including text, file and process manipulation. Semantics and syntax of the Perl language, including discussion of the practical kinds of problems that Perl can solve and provides examples. This course has the option of a letter grade or pass/no pass. Concurrent enrollment in CSIS 54L is required. COREQUISITE: CSIS 54L Perl Programming Lab ADVISORY: CSIS 45 C++ Programming or equivalent programming experience.

10931 Lec MHG8 Tarvin J 3.30 3.0 R 0600P-0905P
 Above class meets at Morgan Hill Community site.

CSIS 54L Perl Programming Lab

Transferable: CSU, UC

Supplemental practice in coursework associated with this course is provided. Concurrent enrollment in CSIS 54 is required. COREQUISITE: CSIS 54 Perl Programming

10932 Lab MHG8 Tarvin J 1.00 1.0 R 0905P-1000P
 Above class meets at Morgan Hill Community site.

CSIS 61 Introduction to Geographic Information Systems

Transferable: CSU, UC

The Geographic Information Systems (GIS) class introduces students to and teaches them how to use desktop GIS software. GIS is a computer-based data-processing tool used to analyze and manage spatial information that combines computers and geography. May be repeated three times for credit. This course has the option of a letter grade or pass/no pass. ADVISORY: CSIS 1 or CSIS 2 or equivalent computer experience.

10985 L/L BU111 Boyes R 4.00 4.0 R 0600P-0950P

CSIS 74 Advanced Photoshop

Transferable: CSU; GAV-GE:C1

This course is for the PhotoShop-experienced student and explores PhotoShop's advanced features in depth. Students work on projects, which challenge their creativity and technical ability, and will be encouraged to develop complex projects for the web and for the printed page. May be repeated three times for credit. This course has the option of a letter grade or pass/no pass. This course is also listed as ART 74 and DM 74. ADVISORY: CSIS 75 PhotoShop I

10615 Lec MHG5 Grzan R 3.30 3.0 R 0630P-0935P
 Above class meets at Morgan Hill Community site.

CSIS 75 PhotoShop I - Adobe PhotoShop

Transferable: CSU; GAV-GE:C1

This course is based on the software application Adobe PhotoShop. Students learn to scan photographs and manipulate them using Photoshop tool box and special effects filters. They will learn to correct photos; mask image using channels; create duotone, tritone, and quadtone images; prepare photos for use in printing and on the web. This course has the option of a letter grade or pass/no pass. May be repeated three times for credit. Students who repeat this course will learn new and advanced features. This course is also listed as DM 75. ADVISORY: CSIS 124 (Windows Fundamentals), CSIS 2L

10618 L/L LI128 Beede R 3.20 3.0 MW 0945A-1105A

10629 L/L MHG5 Grzan R 3.30 3.0 T 0630P-0935P
 Above class meets at Morgan Hill Community site.

CSIS 77 Introduction to Digital Media and its Tools

Transferable: CSU, UC; GAV-GE:C1

An introduction to the field of digital media, including history, social impact, concepts, career options and industry trends. Applying learned visual and aural design principles, students will explore the use of computer-based tools in the design and production of digital media by creating and editing digital images, sounds, video, animation, and text. A comprehensive term project for publication on the web or CD ROM will be required. This course is also listed as ART 77 and DM 77. This course has the option of a letter grade or pass/no pass. May be repeated twice for credit. ADVISORY: CSIS 124, CSIS 1, CSIS 2/2L, CSIS 3, or familiarity using the Macintosh or Windows operating system.

10637 L/L LI128 Beede R 3.20 3.0 TR 1120A-1240P

CRN Type Room Instructor Hrs. Units Days Begin-End

CSIS 80 Digital Photography

Transferable: CSU, UC; GAV-GE:C1

The study of digital photography from digital camera to the computer-based printer or digital media. Artistic, theoretical, and technical aspects will be considered. Topics include information about types and purchasing of digital cameras; theory, mechanics, and art of digital imagery; digital darkroom; eccentricities of digital photo taking; stitching photos for virtual reality; and preparing digital images for print, World Wide Web and other digital media. This course has the option of a letter grade or pass/no pass. This course is also listed as ART 80 and DM 80. ADVISORY: CSIS 1 or CSIS 2/2L or ART 8A or equivalent computer experience. \$20 materials fee, payable at registration.

10641 L/L LI128 Edberg J 5.40 3.0 MW 1250P-0315P

CSIS 85 Web Design I: Dreamweaver

Transferable: CSU; GAV-GE:C1

Basic and intermediate principles of designing Web pages/sites using the Dreamweaver web design software and HTML. Emphasis will be on good design and the use of tables, frames, forms, rollovers, DHTML, XHTML, behaviors, and CSS. Also includes site maintenance and the integration of multimedia components such as graphics, sound, animation, and video. This course is for the content person to design, develop, and maintain effective Web sites. This course is also listed as ART 85 and DM 85. This course has the option of a grade or pass/no pass. May be repeated twice for credit. ADVISORY: CSIS 6 or basic knowledge of HTML.

10665 Lec MHG8 Conrey J 3.30 2.0 W 0600P-0905P
09/24/08 - 12/10/08 Above class meets at Morgan Hill Community site.

CSIS 110 Interactive Animation: Flash

Transferable: CSU; GAV-GE:C1

The production of vector graphics, animation, and interactive multimedia in Shockwave-Flash format for web pages and other digital media. Design of highly interactive web site interfaces and animated games using Flash actions (scripting). Useful for web designers/developers, animators, and multimedia authors. This course has the option of a letter grade or pass/no pass. Also listed as ART 110 and DM 110. May be repeated three times for credit. ADVISORY: CSIS 1, CSIS 2/2L, CSIS 124 or basic computer knowledge.

10687 L/L LI128 Beede R 3.20 3.0 MW 1120A-1240P

CSIS 112 Keyboard Speed Building

Transferable: CSU

This self-paced course is designed for students who know the alphabetic keyboard by touch and who want to develop their keyboarding speed. Students will use a microcomputer to keyboard a series of straight-copy timings, which will enable them to achieve a high level of skill. This is a pass/no pass course. May be repeated once for a total of 1 unit. ADVISORY: CSIS 122 or knowledge of keyboard with keyboarding speed of at least 25 wpm.

10725 Lab BU110 Gaffney S .5

CSIS 113 Introduction to Digital Video

Transferable: CSU; GAV-GE:C1

Introduction to the aesthetic and technical aspects of digital video recording, non-linear editing, special effect generation, and production of video (and associated audio) using the personal computer equipped with specialized software such as iMovie, Final Cut Pro, and After Effects. Also considered will be the preparation of digital video for use in interactive media such as CD, DVD, and the World Wide Web. Students will produce a final digital video project on DVD. This course has the option of a letter grade or pass/no pass. May be repeated 2 times for credit. Also listed as ART 113 and DM 113. ADVISORY: CSIS 1 or CSIS 2/2L or equivalent computer experience

10734 L/L LI128 Beede R 3.20 3.0 TR 0945A-1105A

Don't go to the wrong city

MHG = Morgan Hill Community Center site

HOL = Hollister Briggs Building site

CSIS 49
Unix/Linux Shell Programming

A beginning course in UNIX/Linux shell programming, covering theory and concepts, shell variables, decision making commands and looping mechanisms.

4 units



Tuesday evenings in Morgan Hill
Instructor: Dennie Van Tassel

Transferable: UC and CSU

Advanced Photoshop

CSIS 74

Learn the advanced features of **Photoshop CS3** and create professional artwork.



Also listed as ART 74 and DM 74.

CSIS 75 Photoshop I

Learn to scan, correct and manipulate photos with *Adobe Photoshop CS3*

Also listed as ART 75 and DM 75.

Sign Up Now!

DESIGN YOUR OWN WEB SITE!

CSIS 85
Web Design I: Dreamweaver

Now using Dreamweaver CS3

In this course you will learn to design, develop and maintain effective Web sites.

Also listed as ART 85 & DM 85.

CRN Type Room Instructor Hrs. Units Days Begin-End

CSIS 120 Computerized Accounting - QuickBooks

Transferable: CSU

An introduction to computer assisted accounting. Hands-on use of a microcomputer menu-driven accounting package to do general ledger, sales journal, cash receipts journal, cash payments journal, purchases journal, payroll, receivables, payables and related financial reports. This course has the option of a letter grade or pass/no pass. Repeatable whenever a new software package is adopted. This course is also listed as ACCT 120. ADVISORY: CSIS 1 or CSIS 2 or the equivalent computer experience. ACCT 20 or ACCT 101 or ACCT 103 or ACCT 105 or the equivalent accounting experience.

10362	L/L	MHG5	Brown R	3.70	2.0	M	0600P-0905P
Above class meets at Morgan Hill Community site.							
10409	L/L	HOL3	College A	3.30	2.0	F	0530P-0835P
Above class meets at the Hollister Briggs site.							

CSIS 121 Spreadsheet - MS Excel

Transferable: CSU

Introduction to the computer spreadsheet software. A hands-on approach to learning terms, commands, and applications of a spreadsheet program. This course will help prepare students for taking the Excel MOUS (Microsoft Office User Specialist) exams. This course has the option of a letter grade or pass/no pass. May be repeated once for credit when the software changes. Also listed as ACCT 121. ADVISORY: CSIS 1 or CSIS 2 or equivalent computer experience.

10869	Lec	BU111	Conrey J	3.00	2.0	T	1120A-0210P
09/23/08 - 12/09/08							
10871	Lec	HOL3	Thompson F	3.30	2.0	T	0600P-0905P
09/23/08 - 12/09/08 Above class meets at the Hollister Briggs site.							
10959	Lec	BU111	Thompson F	3.70	2.0	W	0600P-0905P

CSIS 122 Computer Keyboarding

Transferable: CSU

A self-paced course for students who wish to master the alphabetic and numeric keyboard on the computer. This course is designed for students who do not know the alphabetic keyboard by "touch" and for those who want to improve their ability to type straight copy with increased speed and accuracy. The course provides "hands-on" instruction to help students reach optimum computer keyboarding skills within a limited time. This is a pass/no pass course. Course may be repeated until 3 units are accrued.

10872	Lab	BU110	Venable E		1.0		
Orientation required. Schedule available in room BU 110. Open entry-open exit.							
10873	Lab	BU110	Venable E		.5		
Orientation required. Schedule available in room BU 110. Open entry-open exit.							
10881	Lab	MHG8	Hampton D	2.00	.5	S	0830A-1020A
09/06/08 - 12/20/08 Above class meets at Morgan Hill Community site.							
10882	Lab	MHG8	Hampton D	4.00	1.0	S	0830A-1220P
09/06/08 - 12/20/08 Above class meets at Morgan Hill Community site.							
10874	Lab	HOL3	Bryson M	3.20	.5	MW	0945A-1105A
Above class meets at the Hollister Briggs site.							
10875	Lab	HOL3	Bryson M	6.00	1.0	MW	0945A-1240P
Above class meets at the Hollister Briggs site.							
10877	Lab	HOL3	Bryson M	3.20	.5	MW	1120A-1240P
Above class meets at the Hollister Briggs site.							
10878	Lab	HOL3	Bryson M	4.60	1.0	MW	1120A-0125P
Above class meets at the Hollister Briggs site.							
10885	Lab	BU110	Gaffney S	2.00	.5	T	0600P-0750P
Orientation required. Schedule available in class BU 110. Open entry-open exit.							
10886	Lab	BU110	Gaffney S	3.30	1.0	T	0600P-0905P
Orientation required. Schedule available in class BU 110. Open entry-open exit.							
10891	Lab	HOL3	Ross Y	2.00	.5	W	0630P-0820P
Above class meets at the Hollister Briggs site.							
10892	Lab	HOL3	Ross Y	3.30	1.0	W	0630P-0935P
Above class meets at the Hollister Briggs site.							

CRN Type Room Instructor Hrs. Units Days Begin-End

CSIS 124 Windows Fundamentals

Transferable: CSU

This course provides fundamental information on the Windows environment for the computer. Introductory Windows operations and file management are covered. This is a pass/no pass course. This course may be repeated three times for credit. ADVISORY: Basic keyboarding skill.

10898	Lec	MHG8	Hampton D	4.00	1.0	S	0830A-1220P
09/13/08 - 10/11/08 Above class meets at Morgan Hill Community site.							
10894	Lec	HOL3	Bryson M	4.60	1.0	MW	0900A-1105A
09/08/08 - 10/08/08 Above class meets at the Hollister Briggs site.							
10893	Lec	BU111	Milar E	1.60	1.0	M	0220P-0340P
09/15/08 - 11/24/08							

CSIS 126 Word Processing - MS Word

Transferable: CSU

This introductory course for word processing with Windows is designed for business and non-business majors. Students will develop word processing skills to create a document, select and edit text, move and copy text, use the spelling, grammar, and thesaurus features, format text, and create headers, footnotes for a research paper. This course has the option of a letter grade or pass/no pass and may be repeated when the software changes. ADVISORY: Eligible for English 260 and basic keyboarding skills.

10901	Lec	MHG8	Hampton D	4.00	2.0	S	0830A-1220P
10/18/08 - 12/20/08 Above class meets at Morgan Hill Community site.							
10904	Lec	MHG8	Conrey J	3.30	2.0	R	0900A-1205P
09/18/08 - 12/11/08 Above class meets at Morgan Hill Community site.							
10900	Lec	BU111	Milar E	1.60	2.0	M	1250P-0210P
10899	Lec	HOL3	Hampton D	3.30	2.0	M	0600P-0905P
09/15/08 - 12/15/08 Above class meets at the Hollister Briggs site.							

CSIS 129 Presentation Graphics - MS PowerPoint

Transferable: CSU

This introductory course in presentation graphics will use Microsoft Office's "PowerPoint" software to create a computerized presentation (slide show) with text and objects. This course is also listed as CMUN 129. This course has the option of a letter grade or pass/no pass. May be repeated three times for credit. ADVISORY: CSIS 126 or word processing skills in the Windows environment.

10903	Lec	HOL3	Bryson M	4.60	1.0	MW	1120A-0125P
11/24/08 - 12/08/08 Above class meets at the Hollister Briggs site.							
10989	Lec	BU111	Venable E	2.00	1.0	F	1200P-0200P
10/03/08 - 12/12/08							

CSIS 140 Basic Digital Film/Video Production

Transferable: CSU, UC; GAV-GE:C1

An on-line self-paced course covering the basics of film/video production and post production (editing) using "easy to use" computer software such as Apple's iMovie. Beneficial for students who are producing a video/film project as a requirement for another college course, extra skills development, or for self interest. Completion of the associated class or personal project in DVD format using either personal video equipment or the equipment in the Digital Media Studio is required. May be repeated twice for credit. This course has the option of a letter grade or pass/no pass. This course is also listed as ART 140 and DM 140.

10909 Online N/A Beede R 1.0
 This online class will be delivered entirely over the Internet. After enrolling, start the class by going to <http://www.gavilan.edu/disted>, and log into the system. Students who have not logged in by 5 pm on the 3rd day may be dropped from the class.

CSIS 178 Applied Networking

Transferable: CSU

This course covers fundamental networking concepts and develops the skills and knowledge to set up and maintain small business/home networks. The course is not hardware or vendor specific. It helps students prepare for the "Network +" certification exam, an industry-wide, vendor-neutral certification program developed and sponsored by the Computing Technology Industry Association (CompTIA). This course has the option of a letter grade or pass/no pass. May be repeated three times for credit. ADVISORY: CSIS 124

10912	L/L	BU118	Robinson V	4.00	4.0	T	0600P-0950P
	ARR	BU118	Robinson V				0400P-0555P

Classroom Locations: Refer to "How to Use This Schedule" on page 6.

CRN Type Room Instructor Hrs. Units Days Begin-End

CSIS 181 PC Hardware

Transferable: CSU

This course examines computing hardware, operating systems, and software applications from a technical side to enable students to select, install, maintain and optimize a computer system. This course will help prepare students to pursue the A+ Hardware Certification. This course has the option of a letter grade or pass/no pass. ADVISORY: CSIS 124, CSIS 1 OR CSIS 2, or equivalent computer experience.

10913 L/L BU120 Robinson V 4.00 4.0 F 0900A-0100P

CSIS 182 Operating Systems

Transferable: CSU

This course will survey current computer operating systems such as Microsoft Windows 98, NT, 2000 and XP. Linux will also be covered. Topics include file system management, systems requirements, network systems integration, security, and regular maintenance procedures. This course has the option of a letter grade or pass/no pass. ADVISORY: CSIS 1 or CSIS 2 or equivalent computer experience

10914	L/L	BU118	Robinson V	4.00	4.0	M	0600P-0950P
	ARR	BU118	Robinson V	2.00			0400P-0555P

CSIS 190 Occupational Work Experience/Computer Science

Transferable: CSU

College credit for learning experience obtained on the job in accordance with a training plan developed cooperatively between the employer, college and student. 75 hours per semester per unit or 60 hours per semester for unpaid experience. This is a pass/no pass course. May be taken for a maximum of 16 work experience units. REQUIRED: Declared vocational major. Concurrent enrollment in seven or more units (including CWE units, except for summer school. For summer school, enrollment in one other class is required). Minimum 2.00 G.P.A.

Mandatory course orientation for the following classes will be conducted Tuesday evening, September 23rd from 5:30-6:30 pm in BU117, Wednesday, Sept. 24th or Thursday Sept. 25th, from 12-1 p.m. in SC 154N. Students need to attend one of the three meetings. Please contact Lynda Kerr, CWE Coordinator at (408) 846-4993 for more information.

10107	Wrk Ex	BU125	Kerr L		1.0		
10108	Wrk Ex	BU125	Kerr L		2.0		
10110	Wrk Ex	BU125	Kerr L		3.0		
10112	Wrk Ex	BU125	Kerr L		4.0		

CSIS 570 Computer Access Evaluation

Transferable: No

This course is intended to provide an in-depth computer access evaluation in order to determine an appropriate access environment for a student with a disability or multiple disabilities. This is a pass/no pass course. May be repeated as necessary based on measurable progress as documented in the Student Educational Contract. This is an open entry, open exit course. ADVISORY: This course is intended for students with a verified disability who show a need for the use of assistive computer programs and/or equipment or demonstrated academic deficit.

10340 Lab LI105 Maringer J 3.20 .5 MW 0810A-0930A

CSIS 571 Computer Assisted Instruction

Transferable: No

This course is an Assistive Computer Technology Lab designed for students who are eligible for Disability Services. The course is designed to improve basic academic skills and/or cognitive processes through the use of appropriate software or to learn assistive devices designed to make computers accessible. Course content is based on individual educational plans which are developed for each student. This is a pass/no pass course. May be repeated as necessary based on measurable progress as documented in the Student Educational Contract. This is an open entry, open exit course. ADVISORY: This course is intended for students with a verified disability who show a need for the use of adaptive computer programs and/or equipment or demonstrated academic deficit.

10341	Lab	LI105	Maringer J		.5		
10344	Lab	LI105	Maringer J		1.0		
10346	Lab	LI105	Maringer J		2.0		

BUSINESS/CSIS DEGREES & CERTIFICATES

- Accounting
- Bioinformatics
- Business Computer Applications
- Business Economics
- Computer Networking
- Computer Programming
- General Business
- General Office
- Medical Office
- Programming for the Internet
- Scientific Programming
- UNIX Operating Systems
- Web Page Production Specialist



Consult the Gavilan Catalog for complete information or visit the website at www.gavilan.edu

CSIS 129

Presentation Graphics - MS Powerpoint

1 unit

Also listed as CMUN 129

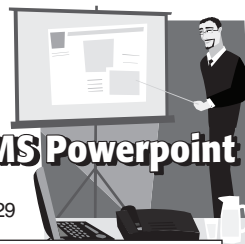

CRN 10903 MW, 11:20 am - 1:25 pm in Hollister
Dates: Nov 24 - Dec 08 Instructor: Margi Bryson

CRN 10989 Fri, 12:00 pm - 2:00 pm on the Gilroy main campus
Dates: Oct 03 - Dec 12 Instructor: Ellen Venable

Learn to Build and Maintain Computers

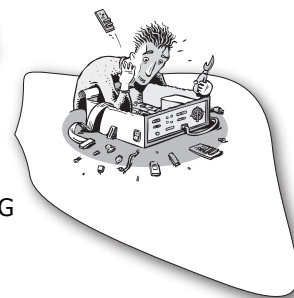

CSIS 178 APPLIED NETWORKING

CSIS 181 PC HARDWARE

CSIS 182 OPERATING SYSTEMS

PREPARATION FOR A+ CERTIFICATION EXAMS
(Get discounts on Exams)

CRN Type Room Instructor Hrs. Units Days Begin-End

CSIS 572 Adaptive Computer Basics

Transferable: No

This course will include an introduction to the basic concept of how computers work, using the computer keyboard, word processing, computer ethics and presentation graphics. This course will be self-paced and adjusted so that students with learning, physical, or communicative disabilities can learn a number of adaptive devices designed to make computers accessible. This is a pass/no pass course. May be repeated as necessary based on measurable progress as documented in the student's Student Educational Contract. This is an open entry, open exit course. ADVISORY: This course is intended for students with a verified disability who show a need for the use of adaptive computer programs and/or equipment or demonstrated academic deficit.

10348 Lab LI105 Maringer J 3.20 1.0 MW 1250P-0210P

Computerized Accounting: see ACCT 120

Construction: see Industrial Technology (IT)

COSMETOLOGY

COS 200 Beginning Cosmetology

Transferable: No

Fundamental principles of the science/art of beauty culture including hair design, chemical services and cosmetic therapy. May be repeated once for credit. ADVISORY: Eligible for English 250, 260 and Mathematics 205.

10558 L/L COS102 Ramirez G 35.20 2.0 T 0810A-0330P
 L/L BU118 Ramirez G 1.60 W 0810A-0930A
 L/L BU120 Ramirez G 1.60 R 0810A-0930A
 L/L LS106 Ramirez G 1.60 F 0810A-0930A
 L/L COS102 Ramirez G 35.20 2.0 WRF 0930A-0330P

COS 201 Intermediate Cosmetology

Transferable: No

Extended studies and techniques in tinting, bleaching, permanent waving, shaping, styling, acrylic nail, pedicuring, chemical straightening, soft perming, waxing, care of skin and make-up. ADVISORY: Satisfactory completion of Cosmetology 200. Eligible for English 250, 260 and Mathematics 205.

10559 L/L COS102 Hernandez R 30.40 2.0 TWRF 0810A-0330P

COS 202 Advanced Cosmetology

Transferable: No

Advanced techniques in tinting, lightening, hair design and cosmetic chemistry. May be repeated once for credit. PREREQUISITE: Completion of COS 200 & 201. ADVISORY: Eligible for English 250, 260 and Mathematics 205.

10560 L/L COS102 Andre M 15.20 2.0 TW 0810A-0330P
 L/L COS102 Khanna N 15.20 RF 0810A-0330P

COS 203 Practicum

Transferable: No

Advanced techniques in tinting, lightening, hair and design and cosmetic chemistry. May be repeated twice for credit. PREREQUISITE: Completion of COS 200, 201 and 202. ADVISORY: Eligible for English 250, 260 and Mathematics 205.

10561 L/L COS102 Andre M 15.20 2.0 TW 0810A-0330P
 L/L COS102 Khanna N 15.20 RF 0810A-0330P
 10562 L/L COS102 Andre M 15.20 4.0 TW 0810A-0330P
 L/L COS102 Khanna N 15.20 RF 0810A-0330P
 10566 L/L COS102 Andre M 15.20 6.0 TW 0810A-0330P
 L/L COS102 Khanna N 15.20 RF 0810A-0330P
 10569 L/L COS102 Andre M 15.20 8.0 TW 0810A-0330P
 L/L COS102 Khanna N 15.20 RF 0810A-0330P
 10570 L/L COS102 Andre M 3.20 TW 0810A-0930A
 L/L COS102 Khanna N 3.20 RF 0810A-0930A
 10572 L/L COS102 Andre M 15.20 2.0 TW 0810A-0330P
 L/L COS102 Khanna N 15.20 RF 0810A-0330P

CRN Type Room Instructor Hrs. Units Days Begin-End

COS 205 State Board Review

Transferable: No

State Board exam procedures and standards. ADVISORY: Cosmetology 201.

10574 Lab COS102 Hernandez R 5.90 2.0 M 0810A-0145P

COS 221 Advanced Scientific Skin Care (Esthetics)

Transferable: No

An advanced in-depth study and training in the care and treatment of skin, cosmetics and manipulative electrical modalities as required by the State Board of Cosmetology. PREREQUISITE: Completion of COS 220 or equivalent.

10940 L/L COS102 Juarez A 20.00 4.0 MTWR 0500P-0950P

COS 290 Occupational Work Experience/Cosmetology

Transferable: No

College credit for learning experience obtained on the job in accordance with a training plan developed cooperatively between the employer, college and student. 75 hours per semester per unit or 60 hours per semester for unpaid experience. This is a pass/no pass course. May be taken for a maximum of 16 work experience units. REQUIRED: Declared vocational major. Concurrent enrollment in seven or more units (including CWE units, except for summer school. For summer school, enrollment in one other class is required). Minimum 2.00 G.P.A.

Mandatory course orientation for the following classes will be conducted Tuesday evening, September 23rd from 5:30-6:30 pm in BU117, Wednesday, Sept. 24th or Thursday Sept. 25th, from 12-1 p.m. in SC 154N. Students need to attend one of the three meetings. Please contact Lynda Kerr, CWE Coordinator at (408) 846-4993 for more information.

10121 Wrk Ex BU125 Kerr L 1.0
 10122 Wrk Ex BU125 Kerr L 2.0
 10123 Wrk Ex BU125 Kerr L 3.0
 10124 Wrk Ex BU125 Kerr L 3.0

CPR: see Allied Health

Desktop Publishing: see CSIS or DM

DIGITAL MEDIA

DM 6 Web Page Authoring I

Transferable: CSU; GAV-GE:E2

An introduction to using Hypertext Mark-Up Language (HTML) and Extensible HTML (XHTML) to create web pages which can be uploaded and displayed on the World Wide Web. Students will use HTML/XHTML to create web pages with text in various sizes and colors, links to other sites, background color or patterns, graphics, tables and mailto links. Principles of design and color as they apply to screen presentations will be included. This course has the option of a letter grade or pass/no pass. May be repeated three times for credit. Also listed as CSIS 6 and LIB 6. ADVISORY: CSIS 1 or CSIS 2 or CSIS 3/LIB 3 advised.

10486 Lec LI126 Littig A 4.60 2.0 TR 0900A-1105A
 09/04/08 - 10/21/08

10473 Online N/A Howell J 2.0
 10/20/08 - 12/14/08 This online class will be delivered entirely over the Internet. After enrolling, start the class by going to <http://www.gavilan.edu/disted>, and log into the system. Students who have not logged in by 5 pm on the 3rd day may be dropped from the class.

10508 Online N/A Venable E 2.0
 09/29/08 - 11/23/08 This online class will be delivered entirely over the Internet. After enrolling, start the class by going to <http://www.gavilan.edu/disted>, and log into the system. Students who have not logged in by 5 pm on the 3rd day may be dropped from the class.

What is a CRN?

CRN stands for Course Reference Number. This is the number (used to be called section) that you will use to register for your classes.

Classroom Locations: Refer to "How to Use This Schedule" on page 6.

CRN Type Room Instructor Hrs. Units Days Begin-End

DM 23 Independent Study

Transferable: CSU

Designed to afford selected students specialized opportunities for exploring areas at the independent study level. The courses may involve extensive library work, research in the community, or special projects. May be repeated until six units of credit are accrued. This course has the option of a letter grade or pass/no pass. REQUIRED: The study outline prepared by the student and the instructor must be filed with the department and the dean.

10915	Ind	LI128	Beede R	1.0			
10916	Ind	LI128	Beede R	1.0			

DM 60 3D Animation I

Transferable: CSU

Fundamentals and aesthetics of digital 3D animation, including modeling, animation and rendering. Focus on computer animation tools and techniques including workflow and storyboarding. Builds a solid foundation for developing character animation, architecture walkthroughs, and special-effect sequences. This course has the option of a letter grade or pass/no pass. May be repeated once for credit. ADVISORY: Any of the following: DM 77, DM 75, DM 76, DM 110, CGD 2, ART 48A, ART 48B, or equivalent.

10917	L/L	LI126	Brownkorb R	3.00	3.0	F	0945A-1240P
-------	-----	-------	-------------	------	-----	---	-------------

DM 61 3D Animation II

Transferable: CSU

This class extends animation into character modeling, soundtrack synchronization, advanced shading, lighting, rendering and compositing techniques. May include topics such as particles, dynamics, and scripting. This course has the option of a letter grade or pass/no pass. ADVISORY: DM 60 or equivalent experience.

10918	L/L	LI126	Brownkorb R	3.20	3.0	TR	1250P-0210P
-------	-----	-------	-------------	------	-----	----	-------------

DM 74 Advanced Photoshop

Transferable: CSU; GAV-GE:C1

This course is for the PhotoShop-experienced student and explores PhotoShop's advanced features in depth. Students work on projects, which challenge their creativity and technical ability, and will be encouraged to develop complex projects for the web and for the printed page. May be repeated three times for credit. This course has the option of a letter grade or pass/no pass. This course is also listed as ART 74 and CSIS 74. ADVISORY: CSIS 75 PhotoShop I

10616	Lec	MHG5	Grzan R	3.30	3.0	R	0630P-0935P
-------	-----	------	---------	------	-----	---	-------------

Above class meets at Morgan Hill Community site.

DM 75 PhotoShop I - Adobe PhotoShop

Transferable: CSU; GAV-GE:C1

This course is based on the software application Adobe PhotoShop. Students learn to scan photographs and manipulate them using Photoshop tool box and special effects filters. They will learn to correct photos; mask image using channels; create duotone, tritone, and quadtone images; prepare photos for use in printing and on the web. This course has the option of a letter grade or pass/no pass. May be repeated three times for credit. Students who repeat this course will learn new and advanced features. This course is also listed as CSIS 75. ADVISORY: CSIS 124 (Windows Fundamentals), CSIS 2L

10619	Lec	LI128	Beede R	3.20	3.0	MW	0945A-1105A
-------	-----	-------	---------	------	-----	----	-------------

10630	L/L	MHG5	Grzan R	3.30	3.0	T	0630P-0935P
-------	-----	------	---------	------	-----	---	-------------

Above class meets at Morgan Hill Community site.

DM 77 Introduction to Digital Media and its Tools

Transferable: CSU, UC; GAV-GE:C1

An introduction to the field of digital media, including history, social impact, concepts, career options and industry trends. Applying learned visual and aural design principles, students will explore the use of computer-based tools in the design and production of digital media by creating and editing digital images, sounds, video, animation, and text. A comprehensive term project for publication on the web or CD ROM will be required. This course is also listed as ART 77 and CSIS 77. This course has the option of a letter grade or pass/no pass. May be repeated twice for credit. ADVISORY: CSIS 124, CSIS 1, CSIS 2/2L, CSIS 3, or familiarity using the Macintosh or Windows operating system.

10639	L/L	LI128	Beede R	3.20	3.0	TR	1120A-1240P
-------	-----	-------	---------	------	-----	----	-------------

SEE YOUR FUTURE IN



You can:
 Make a web site for CyberSpace
 Produce a video for Gav - TV or YouTube
 Record your Podcast for the Internet
 Animate your story or game idea
 Design graphics for web, TV, or print
 Shoot and edit digital photographs

Take:
 DM 77 Intro. to Digital Media
 DM 113 Digital Video/Audio
 DM 110 Interactive Animation: Flash
 DM 60, 61 3D Animation I & II
 DM 80 Digital Photography
 DM 75, 74 Photoshop I & II
 Career info: www.gavilan.edu/DigitalMedia

**DM 110 Interactive Animation: Flash
 DM60, 61 3D Animation I, II**

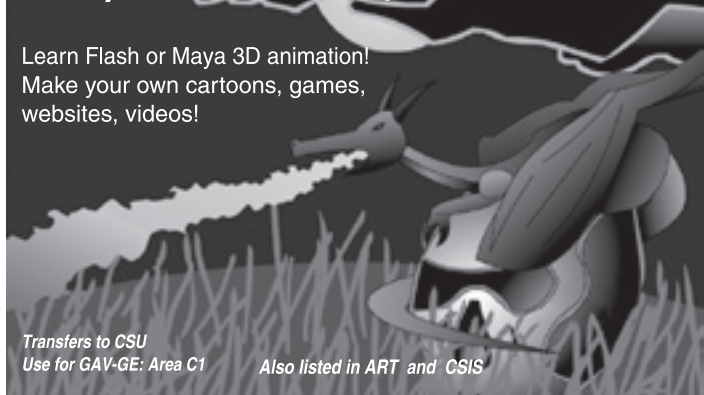

Learn Flash or Maya 3D animation!
 Make your own cartoons, games, websites, videos!

*Transfers to CSU
 Use for GAV-GE: Area C1* *Also listed in ART and CSIS*

CRN Type Room Instructor Hrs. Units Days Begin-End

DM 80 Digital Photography

Transferable: CSU, UC; GAV-GE:C1

The study of digital photography from digital camera to the computer-based printer or digital media. Artistic, theoretical, and technical aspects will be considered. Topics include information about types and purchasing of digital cameras; theory, mechanics, and art of digital imagery; digital darkroom; eccentricities of digital photo taking; stitching photos for virtual reality; and preparing digital images for print, World Wide Web and other digital media. This course has the option of a letter grade or pass/no pass. This course is also listed as ART 80 and CSIS 80. ADVISORY: CSIS 1 or CSIS 2/2L or ART 8A or equivalent computer experience. \$20 materials fee, payable at registration.

10642 L/L LI128 Edberg J 5.40 3.0 MW 1250P-0315P

DM 85 Web Design I: Dreamweaver

Transferable: CSU; GAV-GE:C1

Basic and intermediate principles of designing Web pages/sites using the Dreamweaver web design software and HTML. Emphasis will be on good design and the use of tables, frames, forms, rollovers, DHTML, XHTML, behaviors, and CSS. Also includes site maintenance and the integration of multimedia components such as graphics, sound, animation, and video. This course is for the content person to design, develop, and maintain effective Web sites. This course is also listed as ART 85 and CSIS 85. This course has the option of a letter grade or pass/no pass. May be repeated twice for credit. ADVISORY: CSIS 6 or basic knowledge of HTML.

10670 Lec MHG8 Conrey J 3.30 2.0 W 0600P-0905P
09/24/08 - 12/10/08 Above class meets at Morgan Hill Community site.

DM 110 Interactive Animation: Flash

Transferable: CSU; GAV-GE:C1

The production of vector graphics, animation, and interactive multimedia in Shockwave-Flash format for web pages and other digital media. Design of highly interactive web site interfaces and animated games using Flash actions (scripting). Useful for web designers/developers, animators, and multimedia authors. This course has the option of a letter grade or pass/no pass. Also listed as ART 110 and CSIS 110. May be repeated three times for credit. ADVISORY: CSIS 1, CSIS 2/2L, CSIS 124 or basic computer knowledge.

10690 L/L LI128 Beede R 3.20 3.0 MW 1120A-1240P

DM 113 Introduction to Digital Video

Transferable: CSU; GAV-GE:C1

Introduction to the aesthetic and technical aspects of digital video recording, non-linear editing, special effect generation, and production of video (and associated audio) using the personal computer equipped with specialized software such as iMovie, Final Cut Pro, and After Effects. Also considered will be the preparation of digital video for use in interactive media such as CD, DVD, and the World Wide Web. Students will produce a final digital video project on DVD. This course has the option of a letter grade or pass/no pass. May be repeated 2 times for credit. Also listed as ART 113 and CSIS 113. ADVISORY: CSIS 1 or CSIS 2/2L or equivalent computer experience.

10862 L/L LI128 Beede R 3.20 3.0 TR 0945A-1105A

DM 140 Basic Digital Film/Video Production

Transferable: CSU, UC; GAV-GE:C1

An on-line self-paced course covering the basics of film/video production and post production (editing) using "easy to use" computer software such as Apple's iMovie. Beneficial for students who are producing a video/film project as a requirement for another college course, extra skills development, or for self interest. Completion of the associated class or personal project in DVD format using either personal video equipment or the equipment in the Digital Media Studio is required. May be repeated twice for credit. This course has the option of a letter grade or pass/no pass. This course is also listed as ART 140 and CSIS 140.

10910 Online N/A Beede R 1.0
This online class will be delivered entirely over the Internet. After enrolling, start the class by going to <http://www.gavilan.edu/disted>, and log into the system. Students who have not logged in by 5 pm on the 3rd day may be dropped from the class.

Drama: See Theatre Arts

Early Childhood Education: See Child Development

Earth Science: See Geology, Geography

CRN Type Room Instructor Hrs. Units Days Begin-End

ECOLOGY

ECOL 1 Conservation of Natural Resources

Transferable: CSU, UC; CSU-GE:B3, B2; IGETC:5B; GAV-GE:B3, B2

This course examines the fundamentals of ecology (the study of the relationships between organisms and their environment) with special emphasis on human effects on the environment. Topics of discussion will include ecosystem dynamics, resources, pollution, population growth, and the clash between economic and political policy and the environment. ADVISORY: Eligible for English 250 and English 260.

10887 Lec LS101 Hubbard J 3.20 4.0 TR 1250P-0210P
If you enroll in this class you must enroll in CRN 10888, or 10890.

10888 Lab LS101 Hubbard J 3.30 T 0230P-0535P
If you enroll in this class you must enroll in CRN 10887.

10890 Lab LS101 Hubbard J 3.30 R 0230P-0535P
If you enroll in this class you must enroll in CRN 10887.

ECONOMICS

ECON 1 Principles of Macroeconomics

Transferable: CSU, UC; CSU-GE:D2; IGETC:4B; GAV-GE:D2; CAN:ECON2

Introduction to the principles of macroeconomics, social organization of the economy; supply and demand; the determinants of national income and production, economic growth, the global economy and trade, employment, prices, savings and investment; the nature and effectiveness of monetary and fiscal policy. This course has the option of a letter grade or pass/no pass. ADVISORY: Eligible for English 1A and Mathematics 233.

10919 Lec BU120 TBA 3.20 3.0 MW 1250P-0210P

10920 Lec BU120 TBA 3.20 3.0 TR 1250P-0210P

10921 Lec BU120 TBA 3.30 3.0 M 0600P-0905P

ECON 2 Principles of Microeconomics

Transferable: CSU, UC; CSU-GE:D2; IGETC:4B; GAV-GE:D2; CAN:ECON4

Introduction to microeconomic principles and theory; supply, demand; product and factor price determination, resource allocation, costs, revenues, and profits under different competitive situations; international trade; government regulation and taxation. Note: Economics 1 is not a prerequisite for Economics 2. This course has the option of a letter grade or pass/no pass. ADVISORY: Eligible for English 260, English 250 and Mathematics 233.

10922 Lec BU120 TBA 3.20 3.0 TR 1120A-1240P

10923 Lec BU118 TBA 3.20 3.0 MW 0945A-1105A

ECON 10 Fundamentals of Economics

Transferable: CSU, UC; CSU-GE:D2; IGETC:4B; GAV-GE:D2

A survey of economic concepts and systems. Topics to be covered include production and consumption, pricing and competition, economic growth, inflation, employment, money and banking, and international trade. Not open to students with credit in Economics 1 or 2. This course has the option of a letter grade or pass/no pass. ADVISORY: Eligible for English 250, English 260.

10933 Lec HOL1 Shokou A 3.30 3.0 T 0215P-0520P
Above class meets at the Hollister Briggs site.

ECON 14 Personal Finance

Transferable: CSU

This course is designed to assist individuals to analyze their financial affairs for lifelong decision making. Elements and concepts of financial planning and decision making in the areas of budgeting, taxes, borrowing, money management, insurance, investments, retirement, and estate planning will be examined. This course is also listed as BUS 14. This course has the option of a letter grade or pass/no pass. ADVISORY: Math 400

10438 Lec HOL2 Ross Y 3.30 3.0 S 0800A-1105A
Above class meets at the Hollister Briggs site. Dually listed course. Refer to Gavilan College Catalog.

Education: see Child Development

Choose a **THEME** for your English class:

Find the number, by the course section number, that corresponds to a theme below.



- 1 Explore American consumerism and wild alternatives.
- 2 Explore the great American classics.
- 3 Explore how literature can both forge new entry points and maintain existing boundaries between individuals and communities. Focus on images of race, ethnicity, gender and sexuality in classic plays, American poetry and modern fiction.
- 4 Explore the great literature of the human condition, challenging you to respond to literary art, science fiction, music, tragedy and the joy of life and living.
- 5 Explore a little basic science and technology on the way to becoming a competent, college-level writer.

- 6 Investigate environmental issues, particularly those connected to what we eat and where we live.
- 7 Delve into Chicano/Latino literature.
- 8 Delve into the theme of overcoming hardships.
- 9 Enjoy reading and writing the personal journey.
- 10 Enjoy reading and writing the hero.
- 11 Puente: Focus on Mexican American/Latino literature.
- 12 Learn to be a skeptic, ask questions, take nothing for granted and have the courage of your convictions. Not for those convinced that all life's answers lie in the paranormal and supernatural.
- 13 Explore issues of war and coming of age.
- 14 Investigate urgent social issues through contemporary literature.
- 15 Take a different look at the wars we all think we know, through the literature and personal accounts of writers such as John Steinbeck, Eve Ensler and Lousi DeBernais.

ENGLISH

ENGL 1A Composition

Transferable: CSU, UC; CSU-GE:A2; IGETC:1A; GAV-GE:A2; CAN:ENGL2, ENGL SEQ A

This is a writing course which emphasizes expository writing, argumentative writing, and critical reading of expository prose. It is meant to train students in clear thinking and reasoned support of ideas. Students will be given the opportunity to read models of good expository and argumentative prose and learn the techniques of good writing. These include choosing appropriate subjects, developing restricted, unified, and precise theses and presenting supporting evidence in a logical, lucid, and effective manner. To achieve this end, students write no fewer than six essays and read at least five works, two of which are book length. **PREREQUISITE:** English 250 and English 260 or English 250 and SSCI 270A or English 250 and SSCI 270B with a grade of 'C' or better or satisfactory score on the English placement examination.

Tutorial help is offered for ENGL 1A classes. See your instructor.

10042	Lec	SS203	Pirani A	3.20	3.0	MW	0810A-0930A
10043	Lec	MHG3	McMillen J	3.20	3.0	TR	0810A-0930A
Above class meets at Morgan Hill Community site.							
10046	Lec	SS203	Mora G	3.20	3.0	MW	0945A-1105A
10047	Lec	PB14	Condon D	3.20	3.0	TR	0945A-1105A
10048	Lec	SS203	Jackson S	3.30	3.0	F	0945A-1250P
10050	Lec	HOL6	Mora G	3.20	3.0	MW	0230P-0350P
Above class meets at the Hollister Briggs site.							
10051	Lec	PB14	Salvin C	3.20	3.0	MW	1120A-1240P
10052	Lec	SS203	Jackson S	3.20	3.0	TR	1250P-0210P
10053	Lec	SS203	Draegan K	3.20	3.0	MW	0230P-0350P

10055 Online N/A Wisdom K 3.0
This online class will be delivered entirely over the Internet. After enrolling, start the class by going to <http://www.gavilan.edu/disted>, and log into the system. Students who have not logged in by 5 pm on the 3rd day may be dropped from the class.

10056 Online N/A Chaffin C 3.0
This online class will be delivered entirely over the Internet. After enrolling, start the class by going to <http://www.gavilan.edu/disted>, and log into the system. Students who have not logged in by 5 pm on the 3rd day may be dropped from the class.

10064 Lec PB14 Crook E 1.60 T 1120A-1240P
Online N/A Crook E
This HYBRID lecture/online class will be delivered partially over the Internet. See the online syllabus for details. <http://www.gavilan.edu/disted/>

10065 Lec PB14 Crook E 1.60 R 1120A-1240P
Online N/A Crook E 3.0
This HYBRID lecture/online class will be delivered partially over the Internet. See the online syllabus for details. <http://www.gavilan.edu/disted/>

10054 Lec PB14 Jackson S 3.20 3.0 TR 0400P-0520P

2 10057 Lec MHG10 Luoma D 3.30 3.0 T 0600P-0905P
Above class meets at Morgan Hill Community site.

5 10060 Lec HOL1 Brett T 3.30 3.0 W 0600P-0905P
Above class meets at the Hollister Briggs site.

10066 Lec SS203 Pirani A 3.30 3.0 R 0600P-0905P

2 10076 Lec PB14 Luoma D 3.30 3.0 M 0600P-0905P

ENGL 1B Composition and Literature

Transferable: CSU, UC; CSU-GE:C; IGETC:3B; GAV-GE:C2; CAN:ENGL4, ENGL SEQ A

English 1B continues the work begun in 1A, but now the emphasis shifts to writing expository prose in conjunction with reading and analyzing imaginative literature. Students are to write as fledgling critics and use the text as a basis for other forms of reflection. The reading requirement includes short stories, poetry, drama, and at least two novels. Course work will also include fundamentals of research writing. **PREREQUISITE:** English 1A with a grade of "C" or better.

Tutorial help is offered for ENGL 1B classes. See your instructor.

10077 Online N/A Wisdom K 3.0
This online class will be delivered entirely over the Internet. After enrolling, start the class by going to <http://www.gavilan.edu/disted>, and log into the system. Students who have not logged in by 5 pm on the 3rd day may be dropped from the class. Tutorial help is offered for this class. See your instructor.

10079 Online N/A Warren K 3.0
This online class will be delivered entirely over the Internet. After enrolling, start the class by going to <http://www.gavilan.edu/disted>, and log into the system. Students who have not logged in by 5 pm on the 3rd day may be dropped from the class. Tutorial help is offered for this class. See your instructor.

3 10083 Lec PB3 Smith K 3.20 3.0 TR 0945A-1105A

10084 Lec PB14 Osikomaiya J 3.30 3.0 F 1100A-0205P

10085 Lec SS203 Crook E 3.20 3.0 MW 1120A-1240P

14 10091 Lec HOL4 Salvin C 3.20 3.0 TR 1120A-1240P
Above class meets at the Hollister Briggs site.

3 10086 Lec PB14 Smith K 3.20 3.0 TR 1250P-0210P

15 10087 Lec PB14 Oral M 3.20 3.0 MW 0230P-0350P

4 10089 Lec SS203 Brett T 3.30 3.0 T 0600P-0905P

ENGL 1C Critical Reasoning and Writing

Transferable: CSU, UC; CSU-GE:A3; IGETC:1B; GAV-GE:C2

This course is designed to develop critical thinking, reading, and writing skills beyond the level achieved in English 1A. The emphasis is on critical analysis of arguments and the development of the ability to integrate the principles of critical thinking into essay writing. **PREREQUISITE:** English 1A with a grade of "C" or better.

Tutorial help is offered for ENGL 1C classes. See your instructor.

10092 Online N/A Candelaria X 3.0
This online class will be delivered entirely over the Internet. After enrolling, start the class by going to <http://www.gavilan.edu/disted>, and log into the system. Students who have not logged in by 5 pm on the 3rd day may be dropped from the class. Tutorial help is offered for this class. See your instructor.

10097 Lec LS106 Condon D 3.20 3.0 TR 0810A-0930A

10099 Lec MHG11 Luoma D 3.20 3.0 MW 1120A-1240P
Above class meets at Morgan Hill Community site.

10101 Lec PB3 Candelaria X 3.20 3.0 TR 0400P-0520P

12 10104 Lec SS110 Brett T 3.30 3.0 M 0600P-0905P

CRN	Type	Room	Instructor	Hrs.	Units	Days	Begin-End
-----	------	------	------------	------	-------	------	-----------

ENGL 2B Introduction to Multi-Cultural Literature

Transferable: CSU, UC; CSU-GE:C2; IGETC:3B; GAV-GE:C2, F

Students will examine the concept of ethnicity in the context of contemporary American multi-ethnic literature: Native American, Hispanic American, Black American, Asian American. Students will critique this literature using the accepted elements of literary criticism. They will read and analyze selections from each literature and explain their results in journals, oral presentations, a research project and examinations. PREREQUISITE: Eligible for English 1A.

10109	Lec	SS216	Warren K	3.20	3.0	TR	1120A-1240P
-------	-----	-------	----------	------	-----	----	-------------

ENGL 2C Introduction to Film and Fiction

Transferable: CSU, UC; CSU-GE:C2; IGETC:3B; GAV-GE:C2

This is a literature course in analysis of the novel and film as art forms. The student will read several novels, view the films based on the novels, and discuss the difference in techniques, both orally and in writing. PREREQUISITE: Eligible for English 1A.

10106	Lec	SS214	Richards G	3.30	3.0	W	0630P-0935P
-------	-----	-------	------------	------	-----	---	-------------

ENGL 4A British Literature - 449 to 1798 A.D.

Transferable: CSU, UC; CSU-GE:C2; IGETC:3B; GAV-GE:C2; CAN:ENGL8, ENGL SEQ B

This course is a study of the masters of British literature. In English 4A the student studies the years 449 through 1798 A.D. PREREQUISITE: Eligible for English 1A.

10111	Lec	PH102	Sandler S	3.20	3.0	MW	1120A-1240P
-------	-----	-------	-----------	------	-----	----	-------------

ENGL 9A Introduction to Creative Writing

Transferable: CSU, UC; CSU-GE:C2; GAV-GE:C2; CAN:ENGL6

This course includes the writing, reading, and critical discussions of various forms of poetry and fiction. PREREQUISITE: Eligible for English 1A.

10113	Lec	SS216	Tice R	3.20	3.0	MW	1250P-0210P
-------	-----	-------	--------	------	-----	----	-------------

10140	Lec	PB14	Candelaria X	3.30	3.0	W	0530P-0835P
-------	-----	------	--------------	------	-----	---	-------------

ENGL 9B Advanced Creative Writing

Transferable: CSU, UC; CSU-GE:C2; GAV-GE:C2

This class is a continuation of English 9A, with the emphasis shifting to publication. The genre of non-fiction will be the primary focus, but the genres of fiction will also be taught at a more comprehensive level than in English 9A. The process of finding a market for one's work will be followed step by step. The class may compile and publish "Soaring", Gavilan's literary magazine, each spring semester. PREREQUISITE: English 9A with a grade of credit or C or better.

10115	Lec	SS216	Tice R	3.20	3.0	MW	1250P-0210P
-------	-----	-------	--------	------	-----	----	-------------

10141	Lec	PB14	Candelaria X	3.30	3.0	W	0530P-0835P
-------	-----	------	--------------	------	-----	---	-------------

ENGL 9C Poetry Writing

Transferable: CSU, UC; CSU-GE:C2; GAV-GE:C2

This course includes the writing, reading, and critical discussions of various forms of poetry. PREREQUISITE: English 9A with a grade of credit or C or better.

10116	Lec	SS216	Tice R	3.20	3.0	MW	1250P-0210P
-------	-----	-------	--------	------	-----	----	-------------

10142	Lec	PB14	Candelaria X	3.30	3.0	W	0530P-0835P
-------	-----	------	--------------	------	-----	---	-------------

Don't forget

A counselor's signature is required if you take over 17.99 units (spring/fall) or over 5.99 units (summer).

You do not need a counselor's signature to register for a class with a prerequisite that was successfully completed at Gavilan.

Have you met the prerequisite?
It's required!

CRN	Type	Room	Instructor	Hrs.	Units	Days	Begin-End
-----	------	------	------------	------	-------	------	-----------

ENGL 12A Tutoring Writers: Training/Theory & Practice

Transferable: CSU

Fundamentals of compositional theory, the writing process, peer-to-peer communication, interacting with faculty and educational institutions and effective responses to writing will be covered. In addition, students will gain an understanding of the basic history, methodology and practice of writing pedagogy while developing a writing community that aids in connecting them to their own writing practice. ADVISORY: Eligible for English 1A.

Required. Students enrolling in CRNs below must attend an intensive week-long seminar the week prior to the start of fall semester:

08/25/07 - 08/28/07	LI120	SMITH K		MTWR	0930A-0230P
---------------------	-------	---------	--	------	-------------

10143	Lec	LI120	Smith K	2.30	1.0	M	0230P-0435P
-------	-----	-------	---------	------	-----	---	-------------

10144	Lec	LI120	Smith K	2.30	2.0	M	0230P-0435P
-------	-----	-------	---------	------	-----	---	-------------

10145	Lec	LI120	Smith K	2.30	3.0	M	0230P-0435P
-------	-----	-------	---------	------	-----	---	-------------

ENGL 12B Tutoring Writers: Training/Theory & Practice

Transferable: CSU

Fundamentals of compositional theory, the writing process, peer-to-peer communication, interacting with faculty and educational institutions and effective responses to writing will be covered. In addition, students will gain an understanding of the basic history, methodology and practice of writing pedagogy while developing a writing community that aids in connecting them to their own writing practice. ADVISORY: Eligible for English 1A.

Required. Students enrolling in CRNs below must attend an intensive week-long seminar the week prior to the start of fall semester:

08/25/07 - 08/28/07	LI120	SMITH K		MTWR	0930A-0230P
---------------------	-------	---------	--	------	-------------

10146	Lec	LI120	Smith K	2.30	1.0	M	0230P-0435P
-------	-----	-------	---------	------	-----	---	-------------

10148	Lec	LI120	Smith K	2.30	2.0	M	0230P-0435P
-------	-----	-------	---------	------	-----	---	-------------

10150	Lec	LI120	Smith K	2.30	3.0	M	0230P-0435P
-------	-----	-------	---------	------	-----	---	-------------

ENGL 12C Tutoring Writers: Training/Theory & Practice

Transferable: CSU

Fundamentals of compositional theory, the writing process, peer-to-peer communication, interacting with faculty and educational institutions and effective responses to writing will be covered. In addition, students will gain an understanding of the basic history, methodology and practice of writing pedagogy while developing a writing community that aids in connecting them to their own writing practice. ADVISORY: Eligible for English 1A.

Required. Students enrolling in CRNs below must attend an intensive week-long seminar the week prior to the start of fall semester:

08/25/07 - 08/28/07	LI120	SMITH K		MTWR	0930A-0230P
---------------------	-------	---------	--	------	-------------

10151	Lec	LI120	Smith K	2.30	1.0	M	0230P-0435P
-------	-----	-------	---------	------	-----	---	-------------

10153	Lec	LI120	Smith K	2.30	2.0	M	0230P-0435P
-------	-----	-------	---------	------	-----	---	-------------

10155	Lec	LI120	Smith K	2.30	3.0	M	0230P-0435P
-------	-----	-------	---------	------	-----	---	-------------

ENGL 12D Tutoring Writers: Training, Theory & Practice

Transferable: CSU

Fundamentals of compositional theory, the writing process, peer-to-peer communication, interacting with faculty and educational institutions and effective responses to writing will be covered. In addition, students will gain an understanding of the basic history, methodology and practice of writing pedagogy while developing a writing community that aids in connecting them to their own writing practice. ADVISORY: Eligible for English 1A.

Required. Students enrolling in CRNs below must attend an intensive week-long seminar the week prior to the start of fall semester:

08/25/07 - 08/28/07	LI120	SMITH K		MTWR	0930A-0230P
---------------------	-------	---------	--	------	-------------

10156	Lec	LI120	Smith K	2.30	1.0	M	0230P-0435P
-------	-----	-------	---------	------	-----	---	-------------

10158	Lec	LI120	Smith K	2.30	2.0	M	0230P-0435P
-------	-----	-------	---------	------	-----	---	-------------

10160	Lec	LI120	Smith K	2.30	3.0	M	0230P-0435P
-------	-----	-------	---------	------	-----	---	-------------

ENGL 23 Independent Study

Transferable: CSU

Designed to afford selected students specialized opportunities for exploring areas at the independent study level. The courses may involve extensive library work, research in the community, or special projects. May be repeated until six units of credit are accrued. This course has the option of a letter grade or pass/no pass. REQUIRED: The study outline prepared by the student and the instructor must be filed with the department and the dean.

10183	Ind	LI119	Smith K		1.0		
-------	-----	-------	---------	--	-----	--	--

10185	Ind	LI119	Smith K		2.0		
-------	-----	-------	---------	--	-----	--	--

10999	Ind	SS109	Warren K		1.0		
-------	-----	-------	----------	--	-----	--	--

CRN Type Room Instructor Hrs. Units Days Beg: -End

ENGL 250 Practical Writing

Transferable: No; GAV-GE:A2

This course covers writing clear, correct, effective essays and learning preliminary research skills. PREREQUISITE: English 440 or ESL 563 with a grade of 'C' or better or satisfactory score on the English placement examination.

CRN	Type	Room	Instructor	Hrs.	Units	Days	Beg:	-End
10186	Lec	PB14	Sandler S	3.20	3.0	MW	0810A-0930A	
If you enroll in this class you must enroll in CRN 10187 or 10188. This service learning course section involves community work								
10187	Lab	LI120	Sandler S	1.00		T	0810A-0900A	
If you enroll in this class you must enroll in CRN 10186.								
10188	Lab	LI120	Sandler S	1.00		R	0810A-0900A	
If you enroll in this class you must enroll in CRN 10186.								
10199	Lec	PB14	Osikomaiya J	3.20	3.0	TR	0810A-0930A	
If you enroll in this class you must enroll in CRN 10201 or 10202.								
10201	Lab	LI171	Osikomaiya J	1.00		F	0810A-0900A	
If you enroll in this class you must enroll in CRN 10199.								
10202	Lab	LI171	Osikomaiya J	1.00		F	0910A-1000A	
If you enroll in this class you must enroll in CRN 10199.								
10374	Lec	MHG11	McMillen J	3.20	3.0	TR	0945A-1105A	
Above class meets at Morgan Hill Community site. If you enroll in this class you must enroll in CRN 10375 or 10376.								
10375	Lab	MHG11	McMillen J	1.00		T	1115A-1205P	
Above class meets at Morgan Hill Community site. If you enroll in this class you must enroll in CRN 10374.								
10376	Lab	MHG11	McMillen J	1.00		R	1115A-1205P	
Above class meets at Morgan Hill Community site. If you enroll in this class you must enroll in CRN 10374.								
10378	Lec	PB14	Salvin C	3.20	3.0	MW	0945A-1105A	
If you enroll in this class you must enroll in CRN 10379 or 10380.								
10379	Lab	LI120	Salvin C	1.00		M	0845A-0935A	
If you enroll in this class you must enroll in CRN 10378.								
10380	Lab	LI120	Salvin C	1.00		W	0845A-0935A	
If you enroll in this class you must enroll in CRN 10378.								
10382	Lec	HOL6	Salvin C	1.60	3.0	T	0945A-1105A	
		HOL3	Salvin C	1.60		R	0945A-1105A	
Above class meets at the Hollister Briggs site. If you enroll in this class you must enroll in CRN 10383 or 10386.								
10383	Lab	HOL2	Salvin C	1.00		T	0845A-0935A	
If you enroll in this class you must enroll in CRN 10382.								
10386	Lab	HOL2	Salvin C	1.00		R	0845A-0935A	
If you enroll in this class you must enroll in CRN 10382.								
10389	Lec	SS203	Richards G	3.20	3.0	TR	0945A-1105A	
If you enroll in this class you must enroll in CRN 10390 or 10392.								
10390	Lab	LI120	Richards G	1.00		T	1120A-1210P	
If you enroll in this class you must enroll in CRN 10389.								
10392	Lab	LI120	Richards G	1.00		R	1120A-1210P	
If you enroll in this class you must enroll in CRN 10389.								
10397	Lec	PB14	Oral M	3.20	3.0	MW	1250P-0210P	
If you enroll in this class you must enroll in CRN 10398 or 10399.								
10398	Lab	LI171	Oral M	1.00		F	1210P-0100P	
If you enroll in this class you must enroll in CRN 10397.								
10399	Lab	LI171	Oral M	1.00		F	0110P-0200P	
If you enroll in this class you must enroll in CRN 10397.								
10404	Lec	PB3	Candelaria X	3.20	3.0	TR	0230P-0350P	
If you enroll in this class you must enroll in CRN 10405 or 10406.								
10405	Lab	LI120	Candelaria X	1.00		T	0130P-0220P	
If you enroll in this class you must enroll in CRN 10404.								
10406	Lab	LI120	Candelaria X	1.00		R	0130P-0220P	
If you enroll in this class you must enroll in CRN 10404.								

1 2 3 Your ENGL 250 class has a theme. See list on page 77.

continued

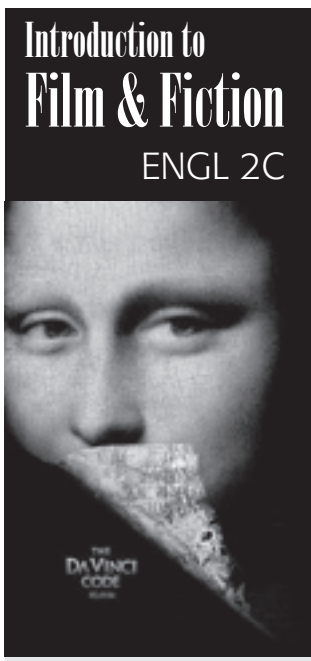

CRN # 10106
 Wednesday
 6:30 pm - 9:35 pm
 Instructor - Grant Richards

- The DaVinci Code*
- Pride and Prejudice*
- Million Dollar Baby*
- Mystic River*
- A History of Violence*
- Cold Mountain*
- Sideways*
- Motorcycle Diaries*
- Closer*
- Fight Club*
- Notebook*
- High Fidelity*
- The Shawshank Redemption*
- To Kill a Mockingbird*
- One Flew Over the Cuckoo's Nest*
- Chocolat*
- LA Confidential*
- Get Shorty*
- and more!*

This class can fulfill your IGETC humanities transfer requirement.

Introduction to Multi-Cultural Literature

Explore our multicultural history, culture, and society through literature.

- Mexican American
- Asian American
- African American
- Native American
- Short stories, novels, poetry
- plays and film

3 units
 Transfer: CSU/UC

ENGL 2B

CRN # 10109
 TuTh 11:20 am - 12:40 pm
 Instructor: Karen Warren

This class can fulfill your IGETC humanities transfer requirement.

ENGL 4A

British Literature 499 to 1798 A.D.

CRN # 10111
 MW 11:20 pm - 12:40 pm
 Instructor: Scott Sandler

CRN	Type	Room	Instructor	Hrs.	Units	Days	Begin-End
ENGL 250 Practical Writing <i>continued from previous page...</i>							
10400	Lec	SS203	Draegan K	3.20	3.0	MW	0400P-0520P If you enroll in this class you must enroll in CRN 10401 or 10402.
10401	Lab	LI120	Draegan K	1.00		M	0530P-0620P If you enroll in this class you must enroll in CRN 10400.
10402	Lab	LI120	Draegan K	1.00		W	0530P-0620P If you enroll in this class you must enroll in CRN 10400.
10407	Lec	SS203	Gardner L	3.20	3.0	MW	0600P-0720P If you enroll in this class you must enroll in CRN 10408 or 10410.
10408	Lab	SS203	Gardner L	1.00		M	0730P-0820P If you enroll in this class you must enroll in CRN 10407.
10410	Lab	SS203	Gardner L	1.00		W	0730P-0820P If you enroll in this class you must enroll in CRN 10407.
10449	Lec	MHG13	Gardner L	3.20	3.0	TR	0700P-0820P Above class meets at Morgan Hill Community site. If you enroll in this class you must enroll in CRN 10450 or 10451.
10450	Lab	MHG13	Gardner L	1.00		T	0830P-0920P Above class meets at Morgan Hill Community site. If you enroll in this class you must enroll in CRN 10449.
10451	Lab	MHG13	Gardner L	1.00		R	0830P-0920P Above class meets at Morgan Hill Community site. If you enroll in this class you must enroll in CRN 10449.

→ continued

Have you met the prerequisite?
It's required!

ENGLISH COMPOSITION AND READING COURSE SEQUENCE

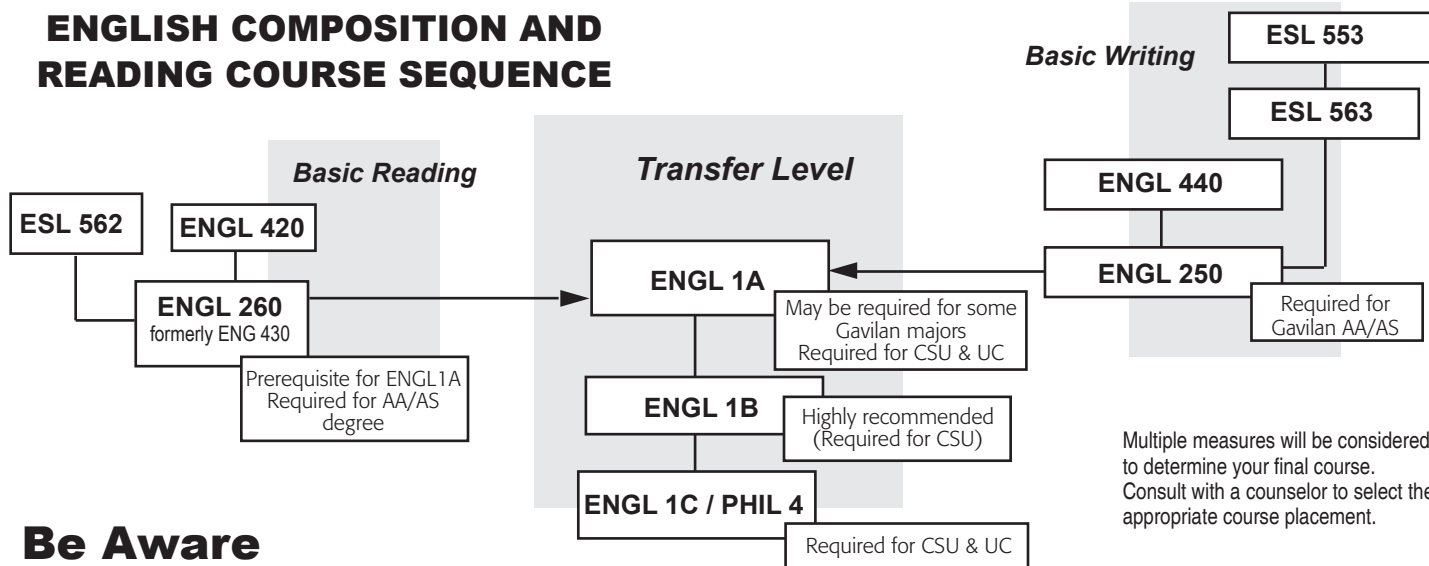

Be Aware

You MAY NOT take courses that overlap (courses that meet at the same day and time)!

Beginning with the summer and fall 2008 enrollment period social security numbers will no longer be used as student identifiers. Find your new Gavilan Student ID and choose a log-on PIN by going to www.gavilan.edu and clicking on the Self-Service Banner icon. You will use your new ID and PIN to log into Self-Service Banner and register for summer and fall classes.

Need a Book Loan?

With an ASB card you can apply for an ASB book loan (up to \$300) at the Financial Aid Office, room SC124. Buy an ASB card at the Admissions & Records Office, room SC111.



CRN	Type	Room	Instructor	Hrs.	Units	Days	Begin-End
FIRST YEAR EXPERIENCE ENGL 250 CLASSES See ad on page 83.							
10946	Lec	PB3	Warren K	3.20	3.0	MW	0945A-1105A If you enroll in this class you must enroll in CRN 10947 or 10948. This class is part of a First Year Experience learning community. You must enroll in ENGL 260: CRN 10949.
10947	Lab	LI120	Warren K	1.00		T	0945A-1035A If you enroll in this class you must enroll in CRN 10946.
10948	Lab	LI120	Warren K	1.00		R	0945A-1035A If you enroll in this class you must enroll in CRN 10946.
10942	Lec	PB3	Warren K	3.20	3.0	MW	1120A-1240P If you enroll in this class you must enroll in CRN 10943 or CRN 10944. This class is part of a First Year Experience learning community. You must also enroll in ENGL 260, CRN 10945.
10943	Lab	LI120	Warren K	1.00		M	0110P-0200P If you enroll in this class you must enroll in CRN 10942.
10944	Lab	LI120	Warren K	1.00		W	0110P-0200P If you enroll in this class you must enroll in CRN 10942.

PUENTE LEARNING COMMUNITY CLASS

10393	Lec	SS203	Sandler S	3.20	3.0	TR	1120A-1240P Students enrolling in this class will participate in the PUENTE Program. Students must attend a mandatory Puente Welcome on Monday, August 25, 2008, 8:30 am - 1:00 pm in SS206. REQUIRED: Complete an application with the Puente Counselor prior to registration. This class is part of a learning community. Students must also enroll in GUID 6, CRN 10952 plus an English lab (either CRN 10395 or 10396).
10395	Lab	LI171	Sandler S	1.00		T	1255P-0145P If you enroll in this class you must enroll in CRN 10393.
10396	Lab	LI171	Sandler S	1.00		R	1255P-0145P If you enroll in this class you must enroll in CRN 10393.

CRN Type Room Instructor Hrs. Units Days Begin-End

ENGL 439 Basic Grammar and Reading

Transferable: No

This is a remediation course introducing basic reading and writing strategies, as well as study skills. Group and individual instruction will be used to build vocabulary, increase reading comprehension, develop study skills, and apply basic grammar to writing. Units earned in this course do not count toward the associate degree and/or certain certificate requirements. This is a pass/no pass course. ADVISORY: Assessment recommendation.

10474	Lec	SS205	Tice R	3.20	4.0	MW	0945A-1105A
	Lab	LI120	Tice R	3.30	4.0	F	0900A-1205P

ENGL 440 Basic Writing

Transferable: No

This is an intensive study and application of basic grammar, sentence, and essay writing skills within the context of composing short essays. Units earned in this course do not count toward the associate degree and/or certain certificate requirements. PREREQUISITE: Satisfactory score on the English placement examination.

8	10476	Lec	SS111	Gatewood J	3.20	3.0	MW	1250P-0210P
---	-------	-----	-------	------------	------	-----	----	-------------

If you enroll in this class you must enroll in CRN 10477 or 10478.

	10477	Lab	LI120	Gatewood J	1.00		F	1210P-0100P
--	-------	-----	-------	------------	------	--	---	-------------

If you enroll in this class you must enroll in CRN 10476.

	10478	Lab	LI120	Gatewood J	1.00		F	0110P-0200P
--	-------	-----	-------	------------	------	--	---	-------------

If you enroll in this class you must enroll in CRN 10476.

8	10479	Lec	PH102	Gatewood J	3.20	3.0	MW	0945A-1105A
---	-------	-----	-------	------------	------	-----	----	-------------

If you enroll in this class you must enroll in CRN 10480 or 10481.

	10480	Lab	LI171	Gatewood J	1.00		F	1010A-1100A
--	-------	-----	-------	------------	------	--	---	-------------

If you enroll in this class you must enroll in CRN 10479.

	10481	Lab	LI171	Gatewood J	1.00		F	1110A-1200P
--	-------	-----	-------	------------	------	--	---	-------------

If you enroll in this class you must enroll in CRN 10479.

	10489	Lec	SS111	Raimondo J	3.20	3.0	TR	0810A-0930A
--	-------	-----	-------	------------	------	-----	----	-------------

If you enroll in this class you must enroll in CRN 10490 or 10492.

	10490	Lab	LI171	Raimondo J	1.00		T	1010A-1100A
--	-------	-----	-------	------------	------	--	---	-------------

If you enroll in this class you must enroll in CRN 10489.

	10492	Lab	LI171	Raimondo J	1.00		R	1010A-1100A
--	-------	-----	-------	------------	------	--	---	-------------

If you enroll in this class you must enroll in CRN 10489.

	10493	Lec	HOL6	Parker V	3.20	3.0	TR	0745P-0905P
--	-------	-----	------	----------	------	-----	----	-------------

Above class meets at the Hollister Briggs site. If you enroll in this class you must enroll in CRN 10495 or 10495.

	10494	Lab	HOL6	Parker V	1.00		T	0910P-1000P
--	-------	-----	------	----------	------	--	---	-------------

Above class meets at the Hollister Briggs site. If you enroll in this class you must enroll in CRN 10493.

	10495	Lab	HOL6	Parker V	1.00		R	0910P-1000P
--	-------	-----	------	----------	------	--	---	-------------

Above class meets at the Hollister Briggs site. If you enroll in this class you must enroll in CRN 10493.

9	10496	Lec	SS111	Arora S	3.20	3.0	MW	0530P-0650P
---	-------	-----	-------	---------	------	-----	----	-------------

If you enroll in this class you must enroll in CRN 10498 or 10497.

	10497	Lab	SS111	Arora S	1.00		M	0700P-0750P
--	-------	-----	-------	---------	------	--	---	-------------

If you enroll in this class you must enroll in CRN 10496.

	10498	Lab	SS111	Arora S	1.00		W	0700P-0750P
--	-------	-----	-------	---------	------	--	---	-------------

If you enroll in this class you must enroll in CRN 10496.

FIRST YEAR EXPERIENCE ENGL 440 CLASSES Depending on which two Lec/Lab CRNs you take, you will be required to also take two specific Lec/Lab ENGL 420 CRNs. See ad on this page.

10	10482	Lec	PH102	Withers M	3.20	3.0	TR	0945A-1105A
----	-------	-----	-------	-----------	------	-----	----	-------------

If you enroll in this class you must enroll in CRN 10483 or 10484.

	10483	Lab	SS216	Withers M	1.00		R	1250P-0140P
--	-------	-----	-------	-----------	------	--	---	-------------

If you enroll in this class you must enroll in CRN 10482.

	10484	Lab	SS216	Withers M	1.00		T	1250P-0140P
--	-------	-----	-------	-----------	------	--	---	-------------

If you enroll in this class you must enroll in CRN 10482.

10	10485	Lec	PB3	Withers M	3.20	3.0	TR	1120A-1240P
----	-------	-----	-----	-----------	------	-----	----	-------------

If you enroll in this class you must enroll in CRN 10487 or 10488.

	10487	Lab	LI120	Withers M	1.00		T	0230P-0320P
--	-------	-----	-------	-----------	------	--	---	-------------

If you enroll in this class you must enroll in CRN 10485.

	10488	Lab	LI120	Withers M	1.00		R	0230P-0320P
--	-------	-----	-------	-----------	------	--	---	-------------

If you enroll in this class you must enroll in CRN 10485.



is a program in place in many schools across the country. These programs are in response to much research supporting smaller schools, interdisciplinary studies, and community building. So what is FYE? At Gavilan, this program links fundamental courses together. By studying and working together with your classmates and instructors, you will develop a stronger network of support. Students who enroll in FYE often report higher GPA, increased involvement in school, more friends, greater ability to meet goals, and stronger critical thinking, reading, and writing abilities.

Mark your calendars! This semester we are also offering two Friday First Year Seminars from 1-3:30 on September 26 and October 24.

The following classes are part of a First Year Experience learning community. You must enroll in both courses.

ENGL 420 Reading Improvement

#10462	Lec	PB3	Hooper J	3.60	3.0	TuTh	1250P-0210P
#10463	Lab	SS216	Hooper J	1.00		Tu	0230P-0320P

ENGL 440 Basic Writing

#10485	Lec	PB3	Withers M	3.20	3.0	TuTh	1120A-1240P
#10488	Lab	LI120	Withers M	1.00		Th	0230P-0320P

_____ or _____

ENGL 420 Reading Improvement

#10462	Lec	PB3	Hooper J	3.60	3.0	TuTh	1250P-0210P
#10464	Lab	SS216	Hooper J	1.00		Th	0230P-0320P

ENGL 440 Basic Writing

#10485	Lec	PB3	Withers M	3.20	3.0	TuTh	1120A-1240P
#10487	Lab	LI120	Withers M	1.00		Tu	0230P-0320P

_____ or _____

ENGL 420 Reading Improvement

#10465	Lec	PH102	Hooper J	3.20	3.0	TuTh	1120A-1240P
#10466	Lab	SS216	Hooper J	1.00		M	1120A-1210P

ENGL 440 Basic Writing

#10482	Lec	PH102	Withers M	3.20	3.0	TuTh	0945A-1105A
#10484	Lab	SS216	Withers M	1.00		T	1250P-0140P

_____ or _____

ENGL 420 Reading Improvement

#10465	Lec	PH102	Hooper J	3.20	3.0	TuTh	1120A-1240P
#10467	Lab	SS216	Hooper J	1.00		W	1120A-1210P

ENGL 440 Basic Writing

#10482	Lec	PH102	Withers M	3.20	3.0	TuTh	0945A-1105A
#10483	Lab	SS216	Withers M	1.00		Th	1250P-0140P

Less Grade Stress!!

Many CSIS and BUS classes may be taken for either a letter grade or on a pass/no pass basis. Make your choice when registering or until the NRS deadline (October 3). See Pass/No Pass Grading Option on page 130 for more details.

Classroom Locations: Refer to "How to Use This Schedule" on page 6.



FIRST YEAR EXPERIENCE cont.

Is this your first year at Gavilan? Looking for a community of people like you? Then this learning community program is specially designed for you. The first year of college can be challenging for many students. By studying and working together with your classmates and instructors, in this program you'll develop a strong network of support to help you succeed. You'll improve your reading and writing skills and also explore options for majors, transferring, and careers. Building a strong foundation in your first year will put you on the road to success throughout your college experience.

The Program: Students will take reading and writing together because these skills are needed to succeed in college classes.

The following classes are part of a First Year Experience learning community. You must enroll in both courses.

ENGL 250 Practical Writing

#10942 LEC PB3 WARREN K 3.20 3.0 MW 1120A-1240P

Choose a lab:

10943 LAB LI120 WARREN K 1.00 M 0110P-0200P

10944 LAB LI120 WARREN K 1.00 W 0110P-0200P

and

ENGL 260 Preparation for College Reading

10945 Lec PB3 Hull K 3.20 3.0 MW 1120A-1240P

or

ENGL 250 Practical Writing

10946 LEC PB3 WARREN K 3.20 3.0 MW 945A-1105A

Choose a lab:

10947 LAB LI120 WARREN K 1.00 Tu 0945A-1035A

10948 LAB LI120 WARREN K 1.00 Th 0945A-1035A

and

ENGL 260 Preparation for College Reading

10949 LEC PB3 HULL K 3.20 3.0 MW 945A-1105A

CRN Type Room Instructor Hrs. Units Days Begin-End

ENGLISH AS A SECOND LANGUAGE

All new ESL students must go through the ESL assessment process. See page 134.

Todos los nuevos estudiantes de ESL deben tomar el examen de nivelación de ESL. Consulte la página 134.

ESL 501 Survival ESL I

Transferable: No

This is a course in survival English for students with little or no oral or written English competency. It will give students basic vocabulary and familiarity in life skill areas such as the family, food, health, and occupations. The course integrates listening, speaking, reading, and writing. (ESL 501, 502, and 503 are sequential courses that may be taken in full form or in halves, preferably A before B.) This is a pass/no pass course. ADVISORY: ESL assessment recommendation

10992 L/L HOL6 Diehl K 8.40 6.0 MWF 0810A-1040A
L/L HOL6 Diehl K 1.60 T 0810A-0930A

Above class meets at the Hollister Briggs site.

ESL 502 Survival ESL II

Transferable: No

This is a second course in survival English for students with little oral or written English competency. It will give students expanded basic vocabulary and familiarity in life skill areas such as the weather, transportation, employment, and American holidays and customs. The course integrates listening, speaking, reading, and writing. (ESL 501, 502, and 503 are sequential courses that may be taken in full form or in halves, preferably A before B.) This is a pass/no pass course. ADVISORY: ESL 501 or ESL 501A and 501B or ESL assessment recommendation

10786 L/L HOL4 Maxwell K 10.00 6.0 MTWRF 0910A-1105A

Above class meets at the Hollister Briggs site.

ESL 503 Survival ESL III

Transferable: No

This is a third course in survival English for students with beginning oral or written English competency. It will reinforce basic skills learned and continue to develop vocabulary and ease of communication in life skill areas such as the family, the larger community, health, employment, and leisure activities. The course integrates listening, speaking, reading, and writing. (ESL 501, 502, and 503 are sequential courses that may be taken in full form or in halves, preferably A before B.) This is a pass/no pass course. ADVISORY: ESL 502 or ESL 502A and ESL 502B or ESL assessment recommendation.

10787 L/L HOL2 Guzman D 10.00 6.0 MTWRF 1115A-0110P

Above class meets at the Hollister Briggs site.

ESL 510A Basic ESL I

Transferable: No

This is an intensive, integrated-skill course for students with little English. Through listening, speaking, reading and writing activities, students learn to use the structures of English with increasing accuracy, while gaining basic life skills. This is a pass/no pass course. ADVISORY: ESL Assessment Recommendation.

10520 L/L CJ500 Campbell K 9.00 9.0 MTWRF 1000A-1130A
ARR TBA 2.00

10524 L/L CJ500 Polizzotto J 9.00 9.0 MTWRF 0810A-0940A
ARR TBA 2.00

ESL 510B Basic ESL II

Transferable: No

This course is a continuation of ESL 510A. This is an intensive, integrated-skill program for students who function in a limited way in English. Through listening, speaking, reading and writing activities, students continue learning to use the structures of English with increasing accuracy, while gaining further basic life skills. This is a pass/no pass course. ADVISORY: ESL 510A or ESL assessment recommendation.

10526 L/L PB12 Baameur K 9.00 9.0 MTWRF 1115A-1245P
ARR TBA 2.00

CRN Type Room Instructor Hrs. Units Days Begin-End

ESL 521 Beginning ESL Listening/Speaking

Transferable: No

This course develops basic listening and speaking skills, moving from a functional survival context to academic readiness. Activities are directed at providing practice through listening exercises, role-play, pair work, small and large group discussion, interviews, and oral presentations. ADVISORY: ESL 510B or ESL Assessment Test Recommendation. Recommended concurrent enrollment in ESL 522 and 523.

10527	L/L ARR	PB13	Wexler L TBA	4.20 2.30	4.0	MWF	0810A-0920A
-------	------------	------	-----------------	--------------	-----	-----	-------------

ESL 522 Beginning ESL Reading/Vocabulary

Transferable: No

This course begins the development of reading skills and vocabulary through the application of different reading strategies to a variety of selections on topics of interest to academically-bound students. ADVISORY: ESL 510B or 510C or Assessment recommendation. Recommended concurrent enrollment in ESL 521 and 523.

10535	L/L ARR	PB13	Cisneros N TBA	3.20 2.40	3.0	TR	0810A-0930A
10785	L/L	PB12	Shelley A	5.60	3.0	TR	0630P-0900P

ESL 523 Beginning ESL Grammar/Writing

Transferable: No

This is a beginning grammar/writing course for students with very basic grammar. The focus is on basic grammatical structures, punctuation and sentence skills. ADVISORY: ESL 510B or ESL Assessment Test recommendation. Recommended concurrent enrollment in ESL 521 and ESL 522.

10536	L/L ARR	PB13	Wexler L TBA	5.20 1.00	5.0	MTWR	1115A-1220P
-------	------------	------	-----------------	--------------	-----	------	-------------

ESL 531 Intermediate ESL Listening/Speaking I

Transferable: No

In this course, listening and speaking skills are developed through extended listening exercises, open-ended dialogues, pair and group discussions, oral interviews, and oral reports. Units earned in this course do not count toward the associate degree and/or certain certificate requirements. ADVISORY: ESL 521 or ESL Assessment Test Recommendation. Recommended concurrent enrollment in ESL 532 and 533.

10773	L/L ARR	PB12	Cisneros N TBA	4.20 2.00	4.0	MWF	0945A-1055A
-------	------------	------	-------------------	--------------	-----	-----	-------------

ESL 532 Intermediate ESL Reading/Vocabulary I

Transferable: No

This course continues the development of reading skills and vocabulary through the application of different reading strategies to a variety of selections on topics of interest to academically-bound students. ADVISORY: ESL 522 or ESL Assessment Recommendation. Recommended concurrent enrollment in ESL 531 and 533.

10774	L/L ARR	PB13	Cisneros N TBA	3.20 2.00	3.0	TR	0945A-1105A
-------	------------	------	-------------------	--------------	-----	----	-------------

ESL 533 Intermediate ESL Grammar/Writing I

Transferable: No

This course involves the practice and refinement of sentence and paragraph skills, structure and punctuation. Students will learn basic use of the computer as a writing tool. Units earned in this course do not count toward the associate degree and/or certain certificate requirements. PREREQUISITE: ESL 523 with a grade of C or better or ESL Assessment Test recommendation. COREQUISITE: Recommended concurrent enrollment in ESL 531 and ESL 532.

10775	L/L ARR	LI100	Lawn B TBA	5.20 1.00	5.0	MTWR	1225P-0130P
-------	------------	-------	---------------	--------------	-----	------	-------------

CRN Type Room Instructor Hrs. Units Days Begin-End

ESL 541 Intermediate ESL Listening/Speaking II

Transferable: No

This course expands listening and speaking skills through extended listening exercises, open-ended dialogues, pair and group discussions, oral interviews, and oral reports. Students broaden vocabulary while listening to and speaking in both formal and informal, conversational and academic situations. ADVISORY: ESL 531 or ESL Assessment Recommendation. Recommended concurrent enrollment in ESL 542 and 543.

10776	L/L ARR	PB13	Sanidad M TBA	4.20 2.00	4.0	MWF	1225P-0135P
-------	------------	------	------------------	--------------	-----	-----	-------------

ESL 542 Intermediate ESL Reading/Vocabulary II

Transferable: No

This course begins the expansion of reading skills and vocabulary development through the application of different reading strategies to a variety of selections on topics of interest to academically-bound students including selections from literature. ADVISORY: ESL 532 or ESL Assessment Recommendation. Recommended concurrent enrollment in ESL 541 and 543.

10777	L/L ARR	LI100	Carrillo L TBA	3.20 2.00	3.0	TR	0810A-0930A
-------	------------	-------	-------------------	--------------	-----	----	-------------

ESL 543 Intermediate ESL Grammar/Writing II

Transferable: No

This course is a continuation of ESL 533. Units earned in this course do not count toward the associate degree and/or certain certificate requirements. PREREQUISITE: ESL 533 with a grade of C or better or ESL assessment recommendation. COREQUISITE: Recommended concurrent enrollment in ESL 541 and ESL 542.

10778	L/L ARR	LI100	Lawn B TBA	5.20 1.00	5.0	TWRF	0945A-1050A
-------	------------	-------	---------------	--------------	-----	------	-------------

ESL 546 Introduction to Computers for ESL Students

Transferable: No

Introduction to basic computer hardware functions and terminology; overview of Windows operating environment and word processing for ESL students. ADVISORY: CSIS 122. Eligible for Gavilan College ESL Program Intermediate.

10784	L/L	BU119	Sanidad M	1.00	1.0	M	1115A-1205P
-------	-----	-------	-----------	------	-----	---	-------------

ESL 552 Advanced ESL Reading/Vocabulary I

Transferable: No

This course focuses on academic and critical thinking skills needed to increase reading comprehension and efficiency. Emphasis is on analyzing, making inferences, taking notes, supporting opinions, summarizing and expanding vocabulary. Readings are from academic texts and literature. ADVISORY: ESL 542 or ESL Assessment Recommendation. Recommended concurrent enrollment in ESL 553 and/or ESL 555.

10779	Lec	PB13	Sanidad M	4.20	4.0	MWF	0945A-1055A
-------	-----	------	-----------	------	-----	-----	-------------

ESL 553 Advanced ESL Composition I

Transferable: No

This course is a composition course for ESL students that develops college composition skills through a review of the parts and elements of the English paragraph and an introduction to the essay form. The course focuses on the development of a paragraph and expands to the writing of multiple paragraphs in an essay. Basic rhetorical patterns and methods of organization are covered using the multiple-draft approach to writing. PREREQUISITE: ESL 543 with a grade of C or better or ESL Assessment Test recommendation. COREQUISITE: Recommended concurrent enrollment in ESL 552 and ESL 554.

10780	L/L ARR	PB12	Campbell K TBA	5.20 1.00	5.0	MTWR	0810A-0915A
-------	------------	------	-------------------	--------------	-----	------	-------------

What is a **CRN**?

CRN stands for Course Reference Number. This is the number (used to be called section) that you will use to register for your classes.

CRN Type Room Instructor Hrs. Units Days Begin-End

ESL 554 Advanced ESL Grammar I

Transferable: No

This course is designed to help students improve their grammar usage so that they will be able to expand their use of grammar structures in oral and written communication. Students begin the study of more sophisticated grammar structures such as past and future perfect, passive voice, and modal auxiliaries for past time, and they review perfect and modals for present and future time. Students will enhance their understanding of grammar by comparing and contrasting new and previously encountered structures and better appreciate the subtleties of English grammar. **PREREQUISITE:** ESL 543 with a grade of 'C' or better or ESL Assessment Test Recommendation. **ADVISORY:** Recommended concurrent enrollment in ESL 552 and ESL 553.

10781	L/L	SS111	Cisneros N	5.20	5.0	TWRF	1115A-1220P
	ARR		TBA	1.00			

ESL 562 Advanced ESL Reading/Vocabulary II

Transferable: No

This course prepares ESL students for mainstream college classes by reviewing a variety of reading skills, strategies, and topics from different academic disciplines. Students expand their academic vocabulary and read short stories or a novel for literary appreciation. **ADVISORY:** ESL 552 or ESL Assessment recommendation. Recommended concurrent enrollment in ESL 563.

10782	Lec	LI100	Lawn B	4.20	4.0	MWF	1105A-1215P
-------	-----	-------	--------	------	-----	-----	-------------

ESL 563 Advanced ESL Composition II

Transferable: No

This course, which is designed for ESL students, refines and further expands college composition skills through the writing of essays using the multiple-draft approach to writing. The course focuses on the structuring and development of an essay with the use of personal examples. Students write in response to a variety of prompts using different rhetorical patterns such as classification, cause/effect, and comparison/contrast. **PREREQUISITE:** ESL 553 with a grade of "C" or better or ESL Assessment Test recommendation. **ADVISORY:** Recommended concurrent enrollment in ESL 562 and ESL 564.

10783	L/L	SS111	Wexler L	5.20	5.0	TWRF	0945A-1050A
	ARR		TBA	1.00			

NEW ESL 585 Editing for ESL Writers

Transferable: No

This course is designed to help second language writers develop self-editing techniques to improve their writing. Students learn to identify and correct grammatical and usage errors in their writing as they become aware of general linguistic rules of English. Students learn to fix, and ultimately avoid, many errors commonly made by second language writers. **ADVISORY:** ESL 554 or ESL Assessment Recommendation.

10995	L/L	LI100	Howell J	3.20	3.0	MW	0810A-0930A
	ARR		TBA	1.00			

Film: see ENGL 2C, HUM 3, 4, 10

Foreign Language: See French (FRNH), Italian (ITAL), Japanese (JPN) and Spanish (SPAN)

FRENCH

FRNH 1A Elementary French

Transferable: CSU, UC; CSU-GE:C2; IGETC:6A; GAV-GE:C2

French 1A is a multi-skilled beginning level class with emphasis on understanding and speaking French. Students are introduced to the cultures and customs of various French-speaking countries.

10634	L/L	HU101	Sanidad M	5.20	5.0	MTWR	0230P-0335P
	ARR			2.8			

*C'est Chic!
Learn French!*



FRNH 1A
Elementary French

CRN 10634
Monday-Thursday
2:30-3:35
Instructor: Mary Ann Sanidad

This course satisfies the general education Humanities (Area C-2) requirement under the AA/AS Degree and the CSU-GE Breadth pattern, and the first half of the language requirement for UC.

**OVERVIEW
of ESL
COURSES**

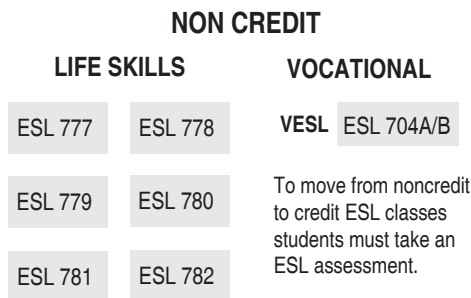

CREDIT

SURVIVAL TRACK

ACADEMIC TRACK

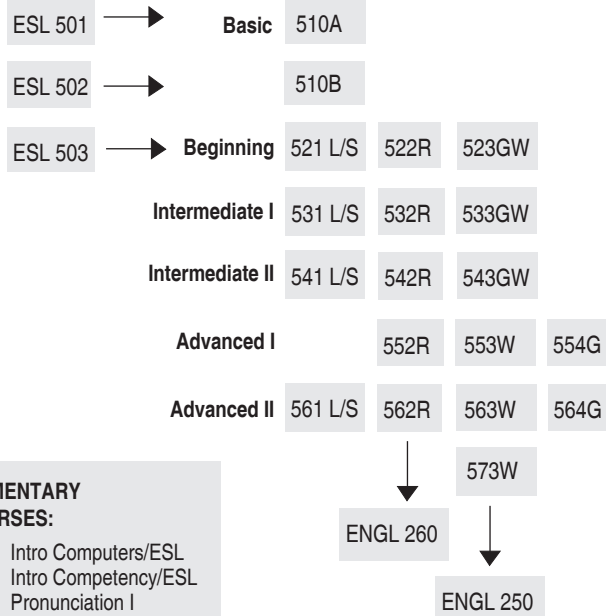

**SUPPLEMENTARY
ESL COURSES:**

- ESL 546 Intro Computers/ESL
- ESL 556 Intro Competency/ESL
- ESL 581 Pronunciation I
- ESL 582 Pronunciation II
- ESL 584 Culture through Film
- ESL 585 Editing for ESL Writers

ACADEMIC PROGRAMS or VOCATIONAL PROGRAMS

CRN Type Room Instructor Hrs. Units Days Begin-End

FRNH 23 Independent Study

Transferable: CSU

Designed to afford selected students specialized opportunities for exploring areas at the independent study level. The courses may involve extensive library work, research in the community, or special projects. May be repeated until six units of credit are accrued. This course has the option of a letter grade or pass/no pass. REQUIRED: The study outline prepared by the student and the instructor must be filed with the department and the dean.

10636 Ind SS104 Sanidad M 2.0

GEOGRAPHY

see also CSIS 61 (Geographic Info. Systems)

GEOG 1 Physical Geography

Transferable: CSU, UC; CSU-GE:B3, B1; IGETC:5A; GAV-GE:B1, B3; CAN:GEOG2

An introductory study of the basic physical elements of geography including climate, land forms, soils, water, and natural vegetation. The laboratory will include the tools and methods of geographers. ADVISORY: Eligible for English 250 and English 260.

10216 L/L MHG12 Willahan D 5.40 3.0 TR 0945A-1210P
Above class meets at Morgan Hill Community site.

GEOLOGY

GEOL 1 Introduction to Geology

Transferable: CSU, UC; CSU-GE:B3, B1; IGETC:5A; GAV-GE:B1, B3; CAN:GEO2L

A study of the earth and the physical properties which modify the earth; minerals, rocks, geologic structures and processes. ADVISORY: Eligible for English 250 and English 260.

10797 L/L SS206 Willahan D 6.60 4.0 TR 1250P-0355P

Government: see Political Science
Graphic Arts: see Art, CSIS, Digital Media

GUIDANCE

GUID 1 Self-Assessment and Career Development

Transferable: CSU; CSU-GE:E2; GAV-GE:E2

This course is designed to assist the student in learning more about personal values, personality, interests, exploration of career choice, and occupational opportunities through the use of various personal assessment instruments. The delivery options for this course also include online and self-paced formats. This course is also listed as PSYC 5. ADVISORY: Eligible for English 250 and English 260. \$12 fee will be charged for career assessment materials.

10010 Lec APE120/121 Godley J 2.30 2.0 W 0810A-1015A

10011 Lec HOL 1 Lopez A 2.30 2.0 W 0230P-0435P
Above class meets at the Hollister Briggs site.

10013 Lec SBHS-194 TBA 2.30 2.0 M 0315P-0520P
This class is part of the High Step Program. It will be offered at San Benito High School, room 194. This class is open to all students. For more information, see a Gavilan counselor.

10668 Lec CJ500 Godley J 2.30 2.0 R 1250P-0255P

10661 Online N/A Sharboneau R 2.0
 This online class will be delivered entirely over the Internet. After enrolling, start the class by going to <http://www.gavilan.edu/disted>, and log into the system. Students who have not logged in by 5 pm on the 3rd day may be dropped from the class.

10673 Online N/A Sharboneau R 2.0
 This online class will be delivered entirely over the Internet. After enrolling, start the class by going to <http://www.gavilan.edu/disted>, and log into the system. Students who have not logged in by 5 pm on the 3rd day may be dropped from the class.

CRN Type Room Instructor Hrs. Units Days Begin-End

GUID 6 Life Skills for Higher Education

Transferable: CSU, UC; CSU-GE:E2; GAV-GE:E2

Evaluation and application of academic study methods to achieve subject matter mastery. Development of critical thinking skills, and application of reading, writing, note taking and test taking methods to improve personal strategies. Exploration of personal lifestyle and health factors, including the causes and management of stress, as it relates to academic success. Assessment of academic and career goals, selection of majors, and development of education plans. Topics covered include creative and realistic goal setting, academic and life management, college and community resources, library and Internet use, time management, and techniques to reduce math and science anxiety. This class will address a multitude of cultural learning styles, with emphasis on attaining professional, personal and academic goals in a diverse society. Topics from developmental psychology, learning theory and personality theory. ADVISORY: Eligible for English 250 and English 260.

10016 Lec APE120/121 Tenney L 2.30 2.0 M 0810A-1015A

10952 Lec LS106 Marquez C 2.30 2.0 W 1120A-0125P
Additional weekly meeting required on Mondays from 11:20 am - 12:10 pm in LS106.

Students enrolling in this class will participate in the PUENTE Program. Students must attend a mandatory Puente Welcome on Monday, August 25, 2008, 8:30 am - 1:00 pm in SS206. REQUIRED: Complete an application with the Puente Counselor prior to registration. This class is part of a learning community. Students must also take English 250, CRN 10393 plus an ENGL 250 lab (either CRN 10395 or 10396).

GUID 22 Field Work and Service

Transferable: CSU

Supervised field work within the college and with local agencies. Students serve in useful group activities in leadership roles prescribed for them by faculty or community agencies. A maximum of six units may be completed. This is a pass/no pass course. REQUIRED: Learning contracts must be filled out and signed by the student and the supervising instructor.

10017 Fld Ex LI117 Eastman B 1.0 day/time - see instructor

GUID 28 Tutoring Techniques

Transferable: CSU

This course is designed to train students in effective tutoring skills, introduction to how people learn, teaching to modalities, and techniques of working with student anxiety. This course has the option of a letter grade or pass/no pass. ADVISORY: English 250.

10971 Lec SS111 King D 2.00 1.0 F 1100A-1240P
Lec LI116 King D 4.00 S 0930A-0130P

09/19/08 - 10/31/08 Please contact Debbie King at the Tutoring Center in LI 116 or call (408) 848-4838 upon enrolling in this class. This class meets seven Fridays, Sept. 9 - Oct. 31 and ONLY ONE Saturday, Sept. 27.

GUID 29 Tutoring Lab

Transferable: CSU

This course will allow students to gain valuable experience in the field of teaching. Students will practice the skills they have learned in Guidance 28. Guidance 29 may be repeated for a maximum of 2.0 units per semester and a maximum course total of 8.0 units. This is a pass/no pass course. ADVISORY: Completion of, or concurrent enrollment in Guidance 28.

10954 Lab LI116 King D 1.0 Open entry-open exit.

10955 Lab LI116 King D 2.0 Open entry-open exit.

GUID 250 Supervised Tutoring

Transferable: No

Laboratory class emphasizing college learning skills, appropriate study techniques, and learning assistance utilizing one-on-one or small group tutorial. Guid 250 is a non-credit class and will not appear on a student's transcript.

10002 Lab LI120 TBA Writing Center

10003 Lab LI116 TBA Tutoring Center

10004 Lab LI116 TBA Tutoring Center

10005 Lab LI168 TBA Computer Place

10006 Lab PH101 TBA Math Lab

10007 Lab HOB104 TBA Allied Health

10008 Lab LI126 TBA Digital Media

10009 Lab LI128 TBA Digital Media

CRN Type Room Instructor Hrs. Units Days Begin-End



GUID 251 College Survival Skills

Transferable: No

A course designed to assist students to adjust to the college environment and the learning process. This course will concentrate on the personal and academic skills necessary for educational success. This is a pass/no pass course.

10991 Lec CJ500 TBA 2.30 1.0 M 1250P-0255P
09/29/08 - 11/17/08

GUID 530 Job Readiness

Transferable: No

This course is designed to provide a comprehensive, well-organized approach to assist individuals with the identification of occupational choices and the development of job readiness skills necessary to obtain and maintain employment in a competitive or supported work setting. May be repeated twice for credit. This course has the option of a letter grade or pass/no pass.

10019 L/L APE120/121 Franklin L 3.20 3.0 TR 0945A-1105A

GUID 557 Learning Skills Assessment

Transferable: No

This course provides an assessment of the students' cognitive/perceptual abilities and basic skills academic achievement. The assessment results are used to determine the students' eligibility for Learning Disabilities Services, to develop individual educational plans, and/or to improve the students' understanding of their own learning strengths and weaknesses. The assessment is conducted on a one-to-one basis by appointment. Units earned in this course do not count toward the associate degree and/or certificate requirements. This is a pass/no pass course.

10983 Lab LI117 Overson R .5 day/time - see instructor
Burgman L

Open entry - open exit.

GUID 558 Learning Skills Laboratory

Transferable: No

The Learning Skills Laboratory is designed to assist students who are eligible to receive Learning Disabilities Services and/or have demonstrated academic deficits. The course content is individualized and based on Student Educational Contracts which are developed for each student. Students receive supplemental instruction, academic support, and learning strategy suggestions appropriate for their individual cognitive, perceptual, and academic strengths and weaknesses. Units earned do not count towards the associate degree and/or certificate requirements. This is a pass/no pass course. ADVISORY: Completion of Guidance 557 or demonstrated academic deficit.

The following classes are open entry-open exit

10023 Lab LI116 Overson R/Burgman L .5 day/time - see instructor
10025 Lab LI116 Overson R/Burgman L 1.0 day/time - see instructor
10204 Lab LI116 Overson R/Burgman L 2.0 day/time - see instructor

GUID 561 Writing Skills

Transferable: No

This course is designed to teach basic writing skills to students who have demonstrated difficulty mastering written language and who are eligible to receive Learning Disability Services. Material is presented in a concrete, multi-sensory manner, and the class includes opportunity for immediate practice, repetition, and review. The course content includes grammar, sentence structure, and punctuation. Units earned do not count toward the associate degree and/or certificate requirements. This course has the option of a letter grade or pass/no pass. ADVISORY: Completion of Guidance 557 or demonstrated deficit in written language achievement. Recommended for students with verified learning disability.

10206 L/L BU117 Maringer J 2.00 1.0 MW 1120A-1220P

GUID 562 Directed Study Lab in Arithmetic

Transferable: No

This course is designed for students who have demonstrated difficulty in mastering arithmetic and who are eligible to receive Learning Disability Services. Course content parallels Mathematics 400. Material is presented in a concrete, multi-sensory manner, and the lab allows opportunity for immediate practice, questions, repetition, and review. Units earned do not count toward the associate degree and/or certificate requirements. This is a pass/no pass course. CO-REQUISITE: Concurrent enrollment in MATH 400. ADVISORY: Completion of GUID 557 and/or a demonstrated deficit in arithmetic. Recommended for students with verified learning disability.

10208 Lab BU117 Burgman L 3.20 1.0 TR 1120A-1240P



Service Learning
for community social change

Would you like to raise your grades, connect class material with the real world, and help somebody else as you become culturally competent in your own community? **Try a Service Learning class!** These classes allow you to work at a community non-profit partner agency as part of your coursework, and help you see how academic material applies in your own community!

The following fall 2008 courses at Gavilan will offer Service Learning:

ANTH 3	Intro to Cult Anth	CRN 10213	3 units	MW	230P-350P
ART 14	Beg Mural Painting	CRN 10563	3 units	F	0900A-0105P + 2 arranged hours per week
CMUN 10	Small Group Comm	CRN 10626	3 units	MW	0810A-0930A
		CRN 10627	3 units	TR	0945A-1105A
		CRN 10625	3 units	T	0230P-0535P
ENGL 250	Practical Writing	CRN 10186	3 units	MW	0810A-0930A
HIST 3	Hist of California	CRN 10245	3 units	TR	1250P-0210P
HIST 5	Women's Lives in US History	CRN 10248	3 units	MW	1120A-1240P
POLS 1	Intro to Am Gov	CRN 10272	3 units	TR	0230P-0350P
SOC 1B	Intro to Sociology	CRN 10349	3 units	MW	1250P-0210P
		CRN 10352	3 units	TR	1250P-0210P
THEA 23	Independent Study	CRN 10769	1 unit		
		CRN 10770	2 units		

For Independent Study: The study outline prepared by the student and the instructor must be filed with the department and the dean.



The Puente Project combines three components: writing, counseling and mentoring to support students to transfer to four-year universities and colleges. The Guidance 6 course focuses on life skills for higher education and transfer. The English 250 course focuses on Mexican American/Latino literature. The program is open to all eligible students and includes a student leadership conference, university visits and mentor/student socials. For more information, call Celia Marquez, Puente Co-Coordinator at 408-848-4807.

Required: Complete a program application with the Puente Counselor prior to registration. Students must attend a mandatory Puente Welcome on Monday, August 25, 2008, 8:30 am - 1:00 pm in SS206.

ENGL 250	CRN: 10393	SS203	SANDLER S	TuTh	1120A-1240P
Choose one lab:	CRN: 10395	LI171	SANDLER S	Tu	1255P-0145P
	or CRN: 10396	LI171	SANDLER S	Th	1255P-0145P

GUID 6 CRN: 10952 LS106 MARQUEZ C W 1120A-0125P
Additional meeting required on Mondays from 1120 am - 1210 pm in LS106.

CRN Type Room Instructor Hrs. Units Days Begin-End

GUID 563A Directed Study Lab in Algebra

Transferable: No

This course is designed for students who have demonstrated difficulty mastering elementary algebra and who are eligible to receive Learning Disability Services. Course content parallels Mathematics 205A. Material is presented in a concrete, multi-sensory manner, and the lab allows opportunity for immediate practice, questions, repetition, and review. This is a pass/no pass course. COREQUISITE: Concurrent enrollment in MATH 205A is required. ADVISORY: Completion of GUID 557 or demonstrated deficit in mathematics. Recommended for students with verified learning disability.

10212	Lab	APE120/121	Overson R	3.20	1.0	MW	1120A-1240P
	ARR		TBA	1.00			

GUID 564 Directed Study Lab in Pre-Algebra

Transferable: No

This course is designed for students who are eligible to receive Learning Disability Services and/or who have demonstrated difficulty in mastering pre-algebra. The course content parallels Mathematics 402. The material is presented in a concrete, multi-sensory manner, and the lab environment allows opportunity for immediate practice questions, repetition and review. Units earned do not count towards the associate degree and/or certificate requirements. This is a pass/no pass course. COREQUISITE: Concurrent enrollment in MATH 402. ADVISORY: Completion of Guidance 557 and/or a demonstrated deficit in Mathematics. Recommended for students with verified learning disability.

10978	Lab	BU117	Burgman L	3.20	1.0	MW	0945A-1105A
-------	-----	-------	-----------	------	-----	----	-------------

Information Science: see CSIS

HEALTH EDUCATION

HE 1 Health Education

Transferable: CSU, UC; CSU-GE:E2; GAV-GE:E2

This course focuses on attaining individual awareness, critical-thinking skills and self-responsibility relating to personal health. The interaction of individual physical, psychological, social, emotional, spiritual and environmental factors in determining health status is developed through integration of major concepts. This course has the option of a letter grade or pass/no pass. ADVISORY: Eligible for English 250 and English 260.

10529	Lec	LS106	Dodd S	3.20	3.0	TR	0945A-1105A
-------	-----	-------	--------	------	-----	----	-------------

10530 Online N/A Quatre S 3.0
 This online class will be delivered entirely over the Internet. After enrolling, start the class by going to <http://www.gavilan.edu/disted>, and log into the system. Students who have not logged in by 5 pm on the 3rd day may be dropped from the class.

10531	Lec	HOL5	Dodd S	3.30	3.0	W	0600P-0905P
-------	-----	------	--------	------	-----	---	-------------

Above class meets at the Hollister Briggs site.

HE 2 Human Sexuality

Transferable: CSU, UC; CSU-GE:E2; GAV-GE:E2

Assists students in gaining increased knowledge, appreciation, and respect for their own sexuality, as well as others. Approved by the Board of Registered Nursing for 54 hours of continuing education credit (Provider #00892). ADVISORY: Eligible for English 250 and English 260

10533	Lec	LS106	Logan C	3.20	3.0	MW	0945A-1105A
-------	-----	-------	---------	------	-----	----	-------------

10532 Online N/A Quatre S 3.0
 This online class will be delivered entirely over the Internet. After enrolling, start the class by going to <http://www.gavilan.edu/disted>, and log into the system. Students who have not logged in by 5 pm on the 3rd day may be dropped from the class.

CRN Type Room Instructor Hrs. Units Days Begin-End

HISTORY

HIST 1 United States History through Reconstruction

Transferable: CSU, UC; CSU-GE:D6, C2; IGETC:3B, 4F, 7B; GAV-GE:C2, D2; CAN:HIST8, HIST SEQ B

History of the United States from the time before European contact with the Americas through Reconstruction. Emphasis will be placed on distinctive patterns of political, economic, social, intellectual, and geographic developments within their global context. At the conclusion of the course, the student should understand major themes in the history of the United States, and be able to explain various ways in which ideas about federal vs. state power, ethnicity, class, and gender divisions have influenced the nation's development. This course has the option of a letter grade or pass/no pass. ADVISORY: Eligible for English 250 and English 260.

10219	Lec	SS214	Halper L	3.20	3.0	TR	0945A-1105A
-------	-----	-------	----------	------	-----	----	-------------

10221	Lec	SS110	Mosher C	3.20	3.0	MW	0945A-1105A
-------	-----	-------	----------	------	-----	----	-------------

10222	Lec	HOL1	Luna E	3.20	3.0	TR	1120A-1240P
-------	-----	------	--------	------	-----	----	-------------

Above class meets at the Hollister Briggs site.

10217	Lec	SS210	Halper L	3.20	3.0	MW	0230P-0350P
-------	-----	-------	----------	------	-----	----	-------------

10236	Lec	SS214	Halper L	3.30	3.0	R	0600P-0905P
-------	-----	-------	----------	------	-----	---	-------------

HIST 2 United States History Reconstruction to the Present

Transferable: CSU, UC; CSU-GE:D6, C2; IGETC:7B, 3B, 4F; GAV-GE:D2, C2; CAN:HIST10, HIST SEQ B

History of the United States from Reconstruction to the present. Emphasis will be placed on distinctive patterns of political, economic, social, intellectual, and geographic developments within their global context. At the conclusion of the course, the student should understand major themes in the history of the United States, and be able to explain various ways in which ideas about federal vs. state power, ethnicity, class, and gender divisions have influenced the nation's development. This course has the option of a letter grade or pass/no pass. ADVISORY: Eligible for English 250 and English 260.

10238	Online	N/A	Guardino L	3.0			
-------	--------	-----	------------	-----	--	--	--

This online class will be delivered entirely over the Internet. After enrolling, start the class by going to <http://www.gavilan.edu/disted>, and log into the system. Students who have not logged in by 5 pm on the 3rd day may be dropped from the class.

10239	Lec	SS205	Mosher C	3.20	3.0	MW	0810A-0930A
-------	-----	-------	----------	------	-----	----	-------------

10240	Lec	HOL2	Luna E	3.20	3.0	TR	0945A-1105A
-------	-----	------	--------	------	-----	----	-------------

Above class meets at the Hollister Briggs site.

10241	Lec	SS214	Luna E	3.20	3.0	MW	1250P-0210P
-------	-----	-------	--------	------	-----	----	-------------

10237	Lec	HOL2	Luna E	3.30	3.0	T	0600P-0905P
-------	-----	------	--------	------	-----	---	-------------

Above class meets at the Hollister Briggs site.

HIST 3 History of California

Transferable: CSU, UC; CSU-GE:D6, C2; IGETC:4F, 3B; GAV-GE:C2, D2, F

A study of California's history from pre-contact with Europeans to the present day. Social, cultural, economic, political and environmental issues will be explored towards an understanding of California's history. ADVISORY: Eligible for English 1A and English 260.

10245	Lec	SS110	Halper L	3.20	3.0	TR	1250P-0210P
-------	-----	-------	----------	------	-----	----	-------------

This service learning course section involves community work

HIST 4B History of World Societies 1500 to Present

Transferable: CSU, UC; CSU-GE:C2, D6; IGETC:3B, 4F; GAV-GE:C2, D2

A study of major elements in the development of and interactions between world societies, from the dawn of the Renaissance to the modern day. Students will comparatively analyze the social, cultural, geographic, economic, demographic, technological, environmental, and political developments that moved humans from the Middle Ages to the modern era. This course has the option of a letter grade or pass/no pass. ADVISORY: English 250 and English 260.

10243	Lec	SS205	Mosher C	3.30	3.0	M	0600P-0905P
-------	-----	-------	----------	------	-----	---	-------------

What is a **CRN**?
 CRN stands for Course Reference Number.
 This is the number (used to be called section)
 that you will use to register for your classes.

CRN Type Room Instructor Hrs. Units Days Begin-End

HIST 5 Women's Lives in Early United States History

Transferable: CSU, UC; CSU-GE:D4, C2, D6; IGETC:4F, 3B; GAV-GE:C2, D1, D2, F
 This survey course begins with pre-contact peoples and extends to the end of the nineteenth century. The class examines the construction of womanhood through United States history, and the effects of gender, ethnicity, class, and sexual orientation upon women's experiences. Students will study the contributions of various individual women and groups of women in creating the modern United States, and will analyze social, political, economic, and cultural forces affecting women to both join and resist movements for social change. Students will also learn to apply contemporary feminist theory to traditional historical approaches. This course has the option of a letter grade or pass/no pass. **ADVISORY:** Eligible for English 250 and English 260.

10248 Lec SS205 Halper L 3.20 3.0 MW 1120A-1240P
 This service learning course section involves community work

HIST 7A History of Western Civilization

Transferable: CSU, UC; CSU-GE:C2; IGETC:3B; GAV-GE:C2; CAN:HIST2, HIST SEQ A
 A study of major elements in Western heritage from the ancient world to the eighteenth century. Course will survey intellectual, political, social, economic and cultural development of the Western World. **ADVISORY:** English 250 and English 260.

10249 Lec SS205 Kier D 3.20 3.0 TR 0810A-0930A

HIST 12 Cultural History of the Mexican American

Transferable: CSU, UC; CSU-GE:D6, D3, C2; IGETC:4F, 3B; GAV-GE:D2, F
 The Mexican American experience as influenced by society in the United States. Emphasis will be on the historical and contemporary contributions made by the Indian, Spanish, Mexican, and Mexican American. Emphasis will also be on the social, economic, and political milieu of the Mexican American within the context of the American society. This course has the option of a letter grade or pass/no pass. **ADVISORY:** Eligible for English 250 and English 260.

10250 Lec SS214 Luna E 3.20 3.0 MW 0945A-1105A

HIST 21 Ancient Americas: A History through Art

Transferable: CSU, UC; CSU-GE:C1, C2; IGETC:3A; GAV-GE:F
 A critical survey of history through the arts of pre-Columbian natives of North, Central and South America. The course will cover major societies and events from the appearance of major civilizations through the initial colonization efforts of European nations. Due to the distinct history of the Americas, this course uses the arts - architecture, sculpture, ceramics and painting, among others - of ancient societies as a primary source material. This course has the option of a letter grade or pass/no pass. This course is also listed as ART 21. **ADVISORY:** Eligible for English 250.

10568 Lec HOL5 Martinez E 3.20 3.0 TR 0230P-0350P
 Above class meets at the Hollister Briggs site.

HIST 23 Independent Study

Transferable: CSU
 Designed to afford selected students specialized opportunities for exploring areas at the independent study level. The courses may involve extensive library work, research in the community, or special projects. May be repeated until six units of credit are accrued. This course has the option of a letter grade or pass/no pass. **REQUIRED:** The study outline prepared by the student and the instructor must be filed with the department and the dean.

10254 Ind SS112 Luna E 1.0



Brush Up your Software Skills

Most Computer Applications classes are repeatable.

CRN Type Room Instructor Hrs. Units Days Begin-End

HUMANITIES

HUM 3 Introduction to the Cinema

Transferable: CSU, UC; CSU-GE:C2; IGETC:3B; GAV-GE:C2
 This course provides an introduction to the cinema. It includes a view of the inventors and the technological developments that led to the modern motion picture; an historical perspective on the growth and development of cinema including significant films that contributed to its establishment as an art form, a study of film genres such as the comedy, the musical, and the western; the technology of image and sound; and a look at the basic techniques of filmmakers when they attempt to convey meaning. **ADVISORY:** Eligible for English 250 and 260.

10501 Lec SS214 Richards G 3.20 3.0 MW 1120A-1240P
 10502 Lec SS214 Richards G 3.20 3.0 TR 1250P-0210P

HUM 4 Introduction to American Cinema

Transferable: CSU, UC; CSU-GE:C2; IGETC:3B; GAV-GE:C2
 This introductory course in film studies is a survey of the American film industry as an art form, as an industry, and as a system of representation and communication. The course explores how Hollywood films work technically, aesthetically, and culturally to reinforce and challenge America's national self-image. **ADVISORY:** English 440

10555 Online N/A Richards G 3.0
 This online class will be delivered entirely over the Internet. After enrolling, start the class by going to <http://www.gavilan.edu/disted>, and log into the system. Students who have not logged in by 5 pm on the 3rd day may be dropped from the class.

HUM 23 Independent Study

Transferable: CSU
 Designed to afford selected students specialized opportunities for exploring areas at the independent study level. The courses may involve extensive library work, research in the community, or special projects. May be repeated until six units of credit are accrued. This course has the option of a letter grade or pass/no pass. **REQUIRED:** The study outline prepared by the student and the instructor must be filed with the department and the dean.

10504 Ind HU111 Richards G 1.0
 10505 Ind HU111 Richards G 2.0

CRN Type Room Instructor Hrs. Units Days Begin-End

INDUSTRIAL TECHNOLOGY

IT 115 Industrial Safety

Transferable: CSU

This course is an introduction to the construction industry. It will cover the basic skill sets required to earn an entry-level position in various trades in construction. Students will learn basic math, vocabulary, blue print reading and safety skills along with the soft skills required to gain employment. This course has the option of a letter grade or pass/no pass. ADVISORY: Eligible for English 250 and English 260.

10511	Lec	SS205	Wright D	3.30	3.0	W	0600P-0905P
ROP class.							

ITALIAN



ITAL 8A Conversational Italian

Transferable: CSU

This beginning course emphasizes the sound system, pronunciation, and conversational skills used in everyday Italian but also covers vocational building and grammar as well. Students are introduced to the culture, customs, and history of the Italian world. This course has the option of a letter grade or pass/no pass.

10635	Lec	HU101	TBA	3.30	3.0	T	0600P-0905P
-------	-----	-------	-----	------	-----	---	-------------

JOURNALISM

JOUR 10 Mass Media and Society

Transferable: CSU, UC; CSU-GE:C2, D0; IGETC:4J; GAV-GE:C2, D2; CAN:JOUR4

This course helps students understand the 20th century revolution in mass media by focusing on the history, economics and social impact of the newspaper, book publishing, magazine, film, television, public relations, advertising and music industries. Students will study audience, propaganda and mass communication theory; and discuss new technology, ethnic media in the United States, ethical issues and attempts to regulate or control the media. Honors students will complete more in-depth analysis of media issues and will finish a media-related research project. This course is also listed as SOC 10. This course has the option of a letter grade or pass/no pass. ADVISORY: English 250, English 260.

10638	Lec	PB7	TBA	3.20	3.0	MW	0810A-0930A
-------	-----	-----	-----	------	-----	----	-------------

JOUR 18A Working on the Newspaper

Transferable: CSU; GAV-GE:C1

Students interview, write, photograph and do computer assisted design and graphics for the college newspaper, The Gavilan Press. In doing this, they provide the community with an important first amendment forum, learn and educate about the first amendment rights and responsibilities, and acquire journalistic skills, ethics, and habits. ADVISORY: Eligible for English 1A. Typing ability.

10643	Lab	PB15	TBA	4.60	2.0	MW	1120A-0125P
10644	Lab	PB15	TBA	5.40	3.0	MW	1120A-0145P
10645	Lab	PB15	TBA	5.40	4.0	MW	1120A-0145P
	ARR		TBA	3.30			
10646	Lab	PB15	TBA	5.40	5.0	MW	1120A-0145P
	ARR		TBA	6.40			

Your educational plan:

You are expected to take the responsibility for scheduling an appointment with a counselor, preferably at least once a semester. The purpose of this appointment is to develop, review and update your educational plan to ensure that you are taking the appropriate courses to meet your educational goal.

CRN Type Room Instructor Hrs. Units Days Begin-End

JOUR 18B Working on the Newspaper

Transferable: CSU; GAV-GE:C1

Students interview, write, photograph and do computer assisted design and graphics for the college newspaper, The Gavilan Press. In doing this, they provide the community with an important first amendment forum, learn and educate about the first amendment rights and responsibilities and acquire journalistic skills, ethics and habits. ADVISORY: Journalism 18A.

10647	Lab	PB15	TBA	5.40	2.0	MW	1120A-0145P
10648	Lab	PB15	TBA	5.40	3.0	MW	1120A-0145P
10649	Lab	PB15	TBA	5.40	4.0	MW	1120A-0145P
	ARR		TBA	3.30			
10650	Lab	PB15	TBA	5.40	5.0	MW	1120A-0145P
	ARR		TBA	6.40			

JOUR 18C Working on the Newspaper

Transferable: CSU; GAV-GE:C1

Students interview, write, photograph and do computer assisted design and graphics for the college newspaper, The Gavilan Press. In doing this, they provide the community with an important first amendment forum, learn and educate about the first amendment rights and responsibilities and acquire journalistic skills, ethics and habits. ADVISORY: Journalism 18B.

10651	Lab	PB15	TBA	4.60	2.0	MW	1120A-0125P
10652	Lab	PB15	TBA	5.40	3.0	MW	1120A-0145P
10653	Lab	PB15	TBA	5.40	4.0	MW	1120A-0145P
	ARR		TBA	3.30			
10654	Lab	PB15	TBA	5.40	5.0	MW	1120A-0145P
	ARR		TBA	3.30			

JOUR 18D Working on the Newspaper

Transferable: CSU; GAV-GE:C1

Students interview, write, photograph and do computer assisted design and graphics for the college newspaper, The Gavilan Press. In doing this, they provide the community with an important first amendment forum, learn and educate about the first amendment rights and responsibilities and acquire journalistic skills, ethics and habits. ADVISORY: Journalism 18C.

10655	Lab	PB15	TBA	4.60	2.0	MW	1120A-0125P
10656	Lab	PB15	TBA	5.40	3.0	MW	1120A-0145P
10658	Lab	PB15	TBA	5.40	4.0	MW	1120A-0145P
	ARR		TBA	3.30			
10659	Lab	PB15	TBA	5.40	5.0	MW	1120A-0145P
	ARR		TBA	6.40			

JOUR 22 Field Work and Service

Transferable: CSU; GAV-GE:C1

Supervised field work within the college and with local agencies. Students serve in useful group activities in leadership roles prescribed for them by faculty or community agencies. A maximum of six units may be completed. This is a pass/no pass course. REQUIRED: Learning contracts must be filled out and signed by the student and the supervising instructor.

10660	Ind	PB15	TBA		.5		
-------	-----	------	-----	--	----	--	--

JOUR 23 Independent Study

Transferable: CSU; GAV-GE:C1

Designed to afford selected students specialized opportunities for exploring areas at the independent study level. The courses may involve extensive library work, research in the community, or special projects. May be repeated until six units of credit are accrued. This course has the option of a letter grade or pass/no pass. REQUIRED: The study outline prepared by the student and the instructor must be filed with the department and the dean.

10663	Ind	PB15	TBA		2.0		
-------	-----	------	-----	--	-----	--	--

CRN Type Room Instructor Hrs. Units Days Begin-End

JOUR 190 Occupational Work Experience/Journalism

Transferable: CSU

The application of learned theory, knowledge, and skills to a practical job setting related to the student's educational/occupational goal. Employment must be directly related to the student's college educational/occupational goal. Periodic interviews of the students and employers or their representatives will be required. Each student shall be assisted in the development of individualized performance objectives, toward which the learning experience shall be directed. **REQUIRED:** Enrollment in a minimum of seven (7) units, including Cooperative Work Experience, during regular semesters; enrollment in at least one other class in summer session.

Mandatory course orientation for the following classes will be conducted Tuesday evening, September 23rd from 5:30-6:30 pm in BU117, Wednesday, Sept. 24th or Thursday Sept. 25th, from 12-1 p.m. in SC 154N. Students need to attend one of the three meetings. Please contact Lynda Kerr, CWE Coordinator at (408) 846-4993 for more information.

10136	Wrk Ex	BU125	Kerr L	1.0
10137	Wrk Ex	BU125	Kerr L	2.0
10138	Wrk Ex	BU125	Kerr L	3.0
10139	Wrk Ex	BU125	Kerr L	4.0

JAPANESE

JPN 1A Elementary Japanese

Transferable: CSU, UC; CSU-GE:C2; GAV-GE:C2

Beginning course with emphasis on understanding and speaking Japanese; introduction to reading and writing Japanese. This course will also introduce students to Japanese culture and institutions. This course has the option of a letter grade or pass/no pass.

10664	L/L	SS110	Sakai T	5.40	5.0	MW	0230P-0455P
	ARR		Sakai T	2.00			

**JPA Fire Technology
and
JPA Law Enforcement**

see ad below:



Careers in

Law Enforcement • Fire Technology

Probation Officer • Dispatcher

Corrections Officer • Juvenile Hall Counselor

Gavilan College is a member of the South Bay Regional Public Safety Training consortium. This consortium is funded by all colleges regionally to provide vocational specific training which may require special facilities, special training conditions or is presented outside of the schedules of regular college classes. For more information call 408-270-6458.

Law Enforcement: see also Administration of Justice

The Final Word!

Look for the Final Exams schedule on page 117 of this schedule.

Sign up early!



Looking for work in the construction fields?

IT 115 Industrial Safety

Wednesday evenings, 6:00 -9:05 pm
CRN #10511

Learn:

- ⇒ Entry level math
- ⇒ field related vocabulary
- ⇒ safety skills

To take this class for Gavilan credit, register in person or online.

For information about ROP noncredit registration call 408-848-4816.



Make Something Happen!

Learn Something New!

JOUR 10 Mass Media & Society

What impact do mass media have on our society and on our world?

JOUR 18A-D Working on the Newspaper

Become a staff member of The Gavilan Press, Gavilan's independent student newspaper, in print and online!

- ◆ Work in print and online
- ◆ Earn units toward a Media Arts Degree
- ◆ Learn new writing, research and design skills
- ◆ Get published and build a portfolio of your work
- ◆ Gain work experience that will help you land a good job
- ◆ Become part of a team
- ◆ Support free speech at Gavilan College!

CRN	Type	Room	Instructor	Hrs.	Units	Days	Begin-End
-----	------	------	------------	------	-------	------	-----------

LIBRARY

LIB 3 Research Skills

Transferable: CSU

Research and evaluation skills using the Internet and other electronic resources, as well as traditional printed materials. Also listed as CSIS 3. This course has the option of a letter grade or pass/no pass. May be repeated once for credit. ADVISORY: Eligible for English 250 and 260.

10037	Online	N/A	Meader S		2.0		
-------	--------	-----	----------	--	-----	--	--

10/14/08 - 12/08/08 This online class will be delivered entirely over the Internet. After enrolling, start the class by going to <http://www.gavilan.edu/disted>, and log into the system. Students who have not logged in by 5 pm on the 3rd day may be dropped from the class.

LIB 6 Web Page Authoring I

Transferable: CSU; GAV-GE:E2

A introduction to using Hypertext Mark-Up Language (HTML) and Extensible HTML (XHTML) to create web pages which can be uploaded and displayed on the World Wide Web. Students will use HTML/XHTML to create web pages with text in various sizes and colors, links to other sites, background color or patterns, graphics, tables, and mailto links. Principles of design and color as they apply to screen presentations will be included. This course has the option a letter grade or pass/no pass. May be repeated three times for credit. Also listed as CSIS 6 and DM 6. ADVISORY: CSIS 1 or CSIS 2 or CSIS/LIB 3 advised.

10499	Lec	LI126	Littig A	4.60	2.0	TR	0900A-1105A
-------	-----	-------	----------	------	-----	----	-------------

09/04/08 - 10/21/08

10596	Online	N/A	Howell J		2.0		
-------	--------	-----	----------	--	-----	--	--

10/20/08 - 12/14/08 This online class will be delivered entirely over the Internet. After enrolling, start the class by going to <http://www.gavilan.edu/disted>, and log into the system. Students who have not logged in by 5 pm on the 3rd day may be dropped from the class.

10597	Online	N/A	Venable E		2.0		
-------	--------	-----	-----------	--	-----	--	--

09/29/08 - 11/23/08 This online class will be delivered entirely over the Internet. After enrolling, start the class by going to <http://www.gavilan.edu/disted>, and log into the system. Students who have not logged in by 5 pm on the 3rd day may be dropped from the class.

Mass Media: see JOUR 10

MATHEMATICS

MATH 1A Single-Variable Calculus and Analytic Geometry

Transferable: CSU, UC; CSU-GE:B4; IGETC:2A; GAV-GE:B4; CAN:MATH18, MATH SEQ BC

Limits and continuity, analyzing the behavior and graphs of functions, derivatives, implicit differentiation, higher order derivatives, related rates and optimization word problems, Newton's Method, Fundamental Theorem of Calculus, and definite and indefinite integrals. PREREQUISITE: Mathematics 10 or Mathematics 8B with a grade of 'C' or better.

10798	Lec	PH103	Dresch M	4.20	4.0	MWF	1250P-0200P
-------	-----	-------	----------	------	-----	-----	-------------

MATH 1B Single-Variable Calculus and Analytic Geometry

Transferable: CSU, UC; CSU-GE:B4; IGETC:2A; GAV-GE:B4; CAN:MATH20, MATH SEQ BC

This course is a standard second semester Calculus course covering methods of integration, applications of the integral, differential equations, parametric and polar equations, and sequences and series. PREREQUISITE: Mathematics 1A with a grade of 'C' or better.

10799	Lec	PH102	Lockhart L	4.60	4.0	TR	0600P-0805P
-------	-----	-------	------------	------	-----	----	-------------

Don't forget

A counselor's signature is required if you take over 17.99 units (spring/fall) or over 5.99 units (summer).

You do not need a counselor's signature to register for a class with a prerequisite that was successfully completed at Gavilan.

Have you met the prerequisite? **It's required!**

CRN	Type	Room	Instructor	Hrs.	Units	Days	Begin-End
-----	------	------	------------	------	-------	------	-----------

MATH 5 Introduction to Statistics

Transferable: CSU, UC; CSU-GE:B4; IGETC:2A; GAV-GE:B4; CAN:STAT2

Descriptive analysis and presentation of either single-variable data or bivariate data, probability distributions, normal probability distributions, sample variability, statistical inferences involving one and two populations, analysis of variance, linear correlation and regression analysis. Statistical computer software will be extensively integrated as a tool in the description and analysis of data. PREREQUISITE: Mathematics 233 with a grade of 'C' or better. The instructor will be using and supporting a TI-83 Plus graphing calculator in all classroom demonstrations.

10802	Lec	SS206	Jukl H	3.20	3.0	MW	1120A-1240P
	Lab	PH101	Jukl H	1.00		F	1150A-1240P

10803	Lec	PH103	Littig A	3.20	3.0	TR	1120A-1240P
	Lab	PH101	Littig A	1.00		F	1050A-1140A

10804	L/L	CH102	Maisch F	4.60	3.0	TR	0600P-0805P
-------	-----	-------	----------	------	-----	----	-------------

10805	L/L	MHG13	Viarengo A	4.60	3.0	MW	0600P-0805P
-------	-----	-------	------------	------	-----	----	-------------

Above class meets at Morgan Hill Community site.

10970	Online	N/A	Haussermann J		3.0		
-------	--------	-----	---------------	--	-----	--	--

This online class will be delivered entirely over the Internet. After enrolling, start the class by going to <http://www.gavilan.edu/disted>, and log into the system. Students who have not logged in by 5 pm on the 3rd day may be dropped from the class.

MATH 7 Finite Mathematics

Transferable: CSU, UC; CSU-GE:B4; IGETC:2A; GAV-GE:B4; CAN:MATH12

Systems of linear equations and matrices, introduction to linear programming, finance, counting techniques and probability, properties of probability and applications of probability. PREREQUISITE: Mathematics 233 with a grade of 'C' or better.

10800	Lec	CH102	Lockhart L	3.20	3.0	TR	0810A-0930A
-------	-----	-------	------------	------	-----	----	-------------

MATH 8A First Half of Precalculus

Transferable: CSU, UC; CSU-GE:B4; IGETC:2A; GAV-GE:B4

Math 8A prepares the student for the study of calculus by providing important skills in algebraic manipulation, interpretation, and problem solving at the college level. Topics will include basic algebraic concepts, complex numbers, equations and inequalities of the first and second degree, functions, and graphs, linear and quadratic equations, polynomial functions, exponential and logarithmic functions, systems of equations, matrices and determinants, right triangle trigonometry, and the Law of Sines and Cosines. PREREQUISITE: Mathematics 233 with a grade of 'C' or better. The instructor will be using and supporting TI-83 Plus graphing calculator in all classroom demonstrations.

10801	Lec	SS206	Jukl H	4.20	4.0	TRF	0945A-1055A
-------	-----	-------	--------	------	-----	-----	-------------

10806	Lec	SS206	TBA	4.20	4.0	MWF	1250P-0200P
-------	-----	-------	-----	------	-----	-----	-------------

MATH 8B Second Half of Precalculus

Transferable: CSU, UC; CSU-GE:B4; IGETC:2A; GAV-GE:B4

Math 8B prepares students for the study of calculus by providing important skills in algebraic manipulation, interpretation, and problem solving at the college level. Topics will include trigonometric functions, identities, inverse trigonometric functions, and equations; applications of trigonometry, vectors, complex numbers, polar and parametric equations; conic sections; sequences, series, counting principles, permutations, mathematical induction; analytic geometry, and an introduction to limits. PREREQUISITE: Mathematics 8A with a grade of 'C' or better. ADVISORY: Math 208 Survey of Practical Geometry.

10807	Lec	CH102	Lee R	4.60	4.0	MW	0600P-0805P
-------	-----	-------	-------	------	-----	----	-------------

Be Aware If your goal is a MULTIPLE SUBJECT CREDENTIAL, you may need MATH 12, Math for Elementary Teachers.

MATH 12 Mathematics for Elementary Teachers

Transferable: CSU, UC; CSU-GE:B4; GAV-GE:B4

This course is intended for students preparing for a career in elementary school teaching. Emphasis will be on the structure of the real number system, numeration systems, elementary number theory, and problem solving techniques. Technology will be integrated throughout the course. PREREQUISITE: High School Geometry and Math 233 (Intermediate Algebra), or, Math 208 (Plane Geometry) and Math 233 (Intermediate Algebra). All courses must be completed with a grade of 'C' or better.

10808	Lec	MHG12	Kercheval S	3.30	3.0	T	0600P-0905P
-------	-----	-------	-------------	------	-----	---	-------------

Above class meets at Morgan Hill Community site.

CRN Type Room Instructor Hrs. Units Days Begin-End

MATH 205 Elementary Algebra

Transferable: No; GAV-GE:B4

This course is a standard beginning algebra course, including algebraic expressions, linear equations and inequalities in one variable, graphing, equations and inequalities in two variables, integer exponents, polynomials, rational expressions and equations, radicals and rational exponents, and quadratic equations. Mathematics 205, 205A and 205B, and 206 have similar course content. This course may not be taken by students who have completed Mathematics 205B or 206 with a grade of "C" or better. This course may be taken for Mathematics 205B credit (2.5 units) by those students who have successfully completed Mathematics 205A with a grade of "C" or better. PREREQUISITE: MATH 402 with a grade of 'C' or better or assessment test recommendation.

10809	Lec	PH103	TBA	5.00	5.0	MTWRF	0810A-0905A
10811	Lec	PH103	Wagman K	5.20	5.0	MTWR	0945A-1050A
10814	Lec	CH109	Seene M	5.20	5.0	MTWR	1120A-1225P
10810	Lec	MHG13	Kercheval S	5.20	5.0	MTWR	1250P-0155P Above class meets at Morgan Hill Community site.
10812	Lec	CH109	Wagman K	5.20	5.0	MTWR	1250P-0155P
10813	Lec	HOL5	Guenther J	5.20	5.0	MTWR	1250P-0155P Above class meets at the Hollister Briggs site.
10815	Lec	LS101	Jukl H	2.60	5.0	MW	1250P-0155P
	Lec	PH103	Jukl H	2.60		TR	1250P-0155P
10816	Lec	CH109	Dachkova E	5.20	5.0	MTWR	0410P-0515P
10817	Lec	HOL4	Bates R	5.40	5.0	TR	0600P-0825P Above class meets at the Hollister Briggs site.
10818	Lec	MHG13	Butterworth Y	5.40	5.0	TR	0600P-0825P Above class meets at Morgan Hill Community site.

MATH 205A First Half of Elementary Algebra

Transferable: No; GAV-GE:B4

This course is the first half of the Elementary Algebra course. It will cover signed numbers, evaluation of expressions, ratios and proportions, solving linear equations, and applications. Graphing of lines, the slope of a line, graphing linear equations, solving systems of equations, basic rules of exponents, and operations on polynomials will be covered. PREREQUISITE: Effective Fall 2005: MATH 402 with a grade of 'C' or better or assessment test recommendation. ADVISORY: Concurrent enrollment in Guidance 563A is advised.

10819	Lec	CH102	Butterworth Y	4.20	2.5	MWF	0810A-0920A
10820	Lec	PH102	Nari J	4.20	2.5	TRF	1250P-0200P
10821	Lec	PH102	Lockhart L	9.20	2.5	MTWR	0230P-0435P 09/04/08 - 10/25/08
10822	Lec	SS206	Arid A	4.60	2.5	MW	0600P-0805P

MATH 205B Second Half of Elementary Algebra

Transferable: No; GAV-GE:B4

This course contains the material covered in the second half of the Elementary Algebra Course. It will cover factoring, polynomials, solving quadratic equations by factoring, rational expressions and equations, complex fractions, radicals and radical equations, solving quadratic equations by completing the square and the quadratic formula. Application problems are integrated throughout the topics. PREREQUISITE: Math 205A with a grade of 'C' or better. ADVISORY: Concurrent enrollment in Guidance 563B is advised.

10823	Lec	LS103	Dachkova E	4.20	2.5	MWF	1120A-1230P
10824	Lec	PH102	Lockhart L	9.20	2.5	MTWR	0230P-0435P 10/29/08 - 12/20/08

Beginning with the summer and fall 2008 enrollment period social security numbers will no longer be used as student identifiers. Find your new Gavilan Student ID and choose a log-on PIN by going to www.gavilan.edu and clicking on the Self-Service Banner icon. You will use your new ID and PIN to log into Self-Service Banner and register for summer and fall classes.

**Gavilan College
Overview of Math Courses**

Grade of "C" or better required in order to progress to the next course

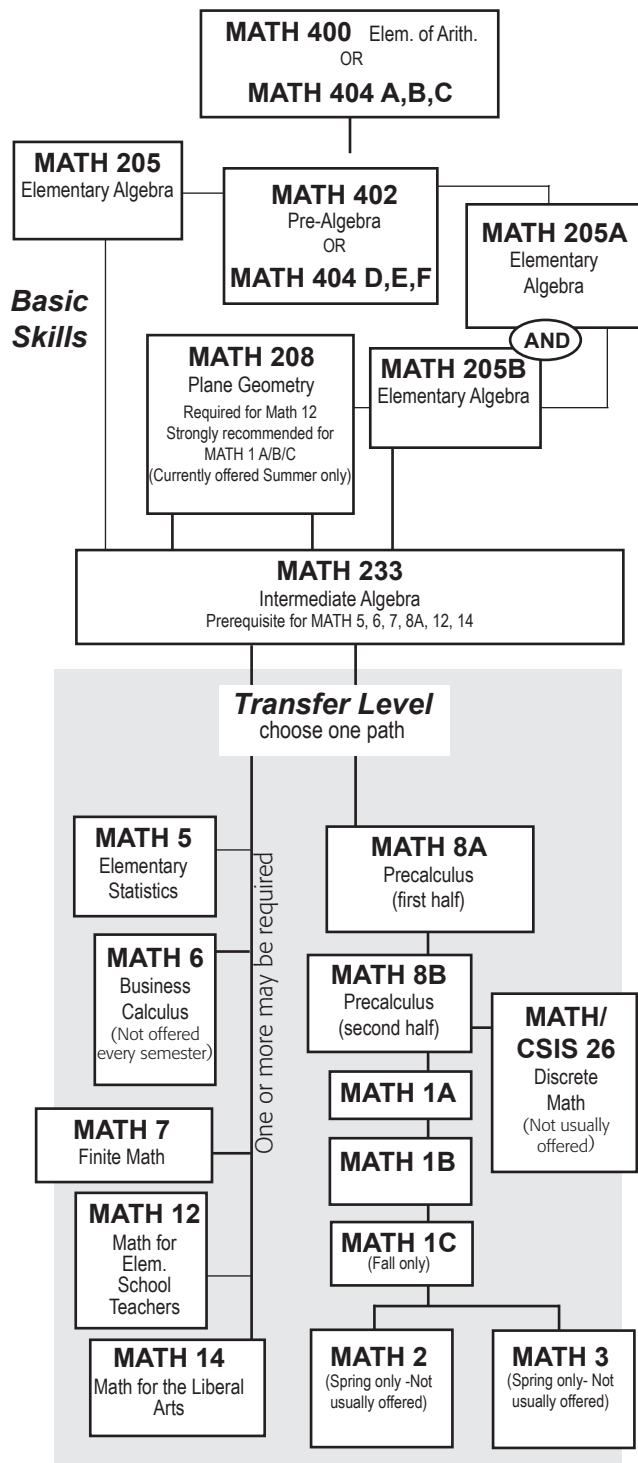

Multiple measures will be considered to determine your final course. Consult with a counselor to select the appropriate course.

CRN Type Room Instructor Hrs. Units Days Begin-End

MATH 233 Intermediate Algebra

Transferable: No; GAV-GE:B4

Review of basic concepts, linear equations and inequalities, graphs and functions, systems of linear equations, polynomials and polynomial functions, factoring, rational expressions and equations, roots, radicals, and complex numbers, solving quadratic equations, exponential and logarithmic functions, and problem solving strategies. Mathematics 233, 233A, and 233B have similar course content. This course may not be taken by students who have completed Mathematics 233B with a grade of 'C' or better. This course may be taken for Mathematics 233B credit (2.5) units by those students who have successfully completed Mathematics 233A with a grade of 'C' or better. PREREQUISITE: Mathematics 205 or Mathematics 205A and 205B or Mathematics 206 with a grade of 'C' or better. The instructor will be using and supporting TI-83 Plus graphing calculator in all classroom demonstrations.

10825	Lec	LS101	Dresch M	5.00	5.0	MTWRF	0810A-0905A
10826	Lec	MHG10	Grover M	5.20	5.0	MTWR	1250P-0155P
Above class meets at Morgan Hill Community site.							
10827	Lec	SS206	TBA	2.60	5.0	MW	0945A-1050A
	Lec	CH109	TBA	2.60		TR	0945A-1050A
10828	Lec	HOL4	Malokas J	5.20	5.0	MTWR	1250P-0155P
Above class meets at the Hollister Briggs site.							
10829	Lec	PH103	Dresch M	3.20	5.0	MW	1120A-1240P
	Lec	PH103	Dresch M	2.00		F	1040A-1240P
10830	Lec	CH102	Lee R	5.20	5.0	MTWR	1250P-0155P
10831	Lec	SS206	Viarengo A	5.20	5.0	MTWR	0410P-0515P
10832	Lec	CH109	Kim D	3.20	5.0	TR	0810A-0930A
	Lec	CH109	Kim D	2.40		F	0810A-1020A
10833	Lec	PH103	Fuller G	5.40	5.0	TR	0600P-0825P

MATH 233A First Half of Intermediate Algebra

Transferable: No

The course will start with a review of basic concepts and then cover the following topics with an emphasis on applications and problem solving strategies: solving linear equations; solving linear, compound, and absolute value inequalities; equations and graphs of lines; functions and function notation including composition of functions; solving systems of linear equations and inequalities; an introduction to matrices and Cramer's rule; operations with polynomials; factoring polynomials; and solving polynomial equations. PREREQUISITE: Completion of Mathematics 205 or the equivalent with a grade of 'C' or better.

10834	Lec	CH102	Seene M	4.20	2.5	MWF	0945A-1055A
10835	Lec	LS101	Grover M	4.60	2.5	TR	0600P-0805P

MATH 233B Second Half of Intermediate Algebra

Transferable: No

This course will start with a review factoring polynomials, and then cover the following topics with an emphasis on applications and problem solving strategies: solving polynomial equations by factoring; adding, subtracting, multiplying, dividing and simplifying rational expressions and solving rational equations; adding, subtracting, multiplying, dividing and simplifying roots, radicals and complex numbers and solving radical equations; the various methods of solving quadratic equations and inequalities; graphing quadratic functions; and working with exponential and logarithmic functions, equations and expressions. PREREQUISITE: Completion of MATH 233A with a grade of 'C' or better.

10836	Lec	LS102	Wagman K	4.20	2.5	TRF	1120A-1230P
-------	-----	-------	----------	------	-----	-----	-------------

MATH 400 Elements of Arithmetic

Transferable: No

Essential arithmetic operations, whole numbers, integers, fractions, decimals, ratio, proportion, percent, applications of arithmetic, and critical thinking, as well as math-specific study skills. Units earned in this course do not count toward the associate degree and/or other certain certificate requirements.

10837	L/L	SS206	Fuller G	4.00	3.0	MTWR	0810A-0905A
10838	Lec	LS103	Dachkova E	3.20	3.0	MW	0945A-1105A
	Lab	LS103	Dachkova E	1.00		F	0945A-1035A
10839	L/L	SS206	Arid A	4.60	3.0	TR	0600P-0805P

CRN Type Room Instructor Hrs. Units Days Begin-End

MATH 402 Pre-Algebra

Transferable: No

This course covers operations with integers, fractions and decimals and associated applications, percentages, ratio, and geometry and measurement, critical thinking and applications. Elementary algebra topics such as variables, expressions, and solving equations are introduced. PREREQUISITE: Completion of Math 400 with a 'C' or better, or assessment test recommendation.

10840	L/L	PH102	Guenther J	4.00	3.0	MTWR	0810A-0905A
10841	Lec	LS101	Nari J	3.20	3.0	TR	1120A-1240P
	Lab	LS101	Nari J	1.00		F	1200P-1250P
10842	L/L	CH109	Juki H	4.20	3.0	MWR	0230P-0340P
10843	L/L	PH102	Washburn A	4.60	3.0	MW	0600P-0805P

MATH 404A-G Self-Paced Basic Math

Transferable: No

This course is a remedial, modular, self-paced course. Application and critical thinking skills are developed in each module. Module A covers operations with whole numbers, equivalent fractions, multiplying and dividing fractions. Module B covers adding and subtracting fractions, and operations with decimals. Module C covers ratio and proportion, percent, and units of measurement. Module D reviews fractions, decimals, percentages, and covers operations with integers, and working with variables. Module E covers real numbers, fractions, exponents, scientific notation, and order of operations. Module F covers expressions, polynomials, and equations. Module G covers geometric figures, perimeter and area, surface area and volume, triangles and parallelograms, and similar figures. This course has the option of a letter grade or pass/no pass. This course involves both lecture and hands-on computer assisted software. All sections are open for late registration. A lab fee of \$60.00 must be paid to the instructor during the first class meeting. Materials included in the lab fee take the place of a textbook. Math 404 A-C is the equivalent of Math 400.

These classes involve both lecture and hands-on computer components. All sections are open for late registration.

MATH 404A

10844	L/L	PH101	Dachkova E	5.60	1.0	MW	1250P-0320P
-------	-----	-------	------------	------	-----	----	-------------

MATH 404B Self-Paced Basic Math

10845	L/L	PH101	Dachkova E	5.60	1.0	MW	1250P-0320P
-------	-----	-------	------------	------	-----	----	-------------

MATH 404C Self-Paced Basic Math

10846	L/L	PH101	Dachkova E	5.60	1.0	MW	1250P-0320P
-------	-----	-------	------------	------	-----	----	-------------

MATH 404D Self-Paced Basic Math

10847	L/L	PH101	Dachkova E	5.60	1.0	MW	1250P-0320P
-------	-----	-------	------------	------	-----	----	-------------

MATH 404E Self-Paced Basic Math

10848	L/L	PH101	Dachkova E	5.60	1.0	MW	1250P-0320P
-------	-----	-------	------------	------	-----	----	-------------

MATH 404F Self-Paced Basic Math

10849	L/L	PH101	Dachkova E	5.60	1.0	MW	1250P-0320P
-------	-----	-------	------------	------	-----	----	-------------

MATH 404G Self-Paced Basic Math

10850	L/L	PH101	Dachkova E	5.60	1.0	MW	1250P-0320P
-------	-----	-------	------------	------	-----	----	-------------

Have you met the prerequisite?
It's required!

CRN Type Room Instructor Hrs. Units Days Begin-End

MARKETING



See ad for new Retail Management Certificate on page 110!

MKTG 100 Principles of Marketing

Transferable: CSU

An introduction to the economic and social problems involved with moving goods and services from the producer to the consumer. This course covers topics such as marketing institutions, channels of distribution, pricing, and government relationships. This course has the option of a letter grade or pass/no pass. ADVISORY: Eligible for English 250 and English 260.

10934	Lec	BU120	TBA	3.30	3.0	W	0630P-0935P
-------	-----	-------	-----	------	-----	---	-------------

This class is the first course in the new Retail Management Certificate. See ad on page 110.

Medical Terminology: see Business

MUSIC

MUS 1A Music History and Literature

Transferable: CSU, UC; CSU-GE:C1; IGETC:3A; GAV-GE:C1; CAN:MUS8

A survey of the development of music in western civilization including representative composers from the Medieval to the present. Music 1A will study the music and styles from the Medieval to the Romantic period. ADVISORY: Eligible for English 250 and English 260.

10666	Lec	PB5	Juncker A	3.20	3.0	TR	0945A-1105A
-------	-----	-----	-----------	------	-----	----	-------------

MUS 3A Harmony - Theory - Musicianship

Transferable: CSU, UC; CSU-GE:C1; GAV-GE:C1

Fundamentals of music, beginning harmony. ADVISORY: Must be taken in sequence.

10669	L/L	PB5	Juncker A	4.60	4.0	MW	1120A-0125P
-------	-----	-----	-----------	------	-----	----	-------------

MUS 3B Harmony - Theory - Musicianship

Transferable: CSU, UC; GAV-GE:C1

Fundamentals of music, beginning harmony. ADVISORY: Must be taken in sequence.

10671	L/L	PB5	Juncker A	4.60	4.0	MW	1120A-0125P
-------	-----	-----	-----------	------	-----	----	-------------

MUS 4A Beginning Piano

Transferable: CSU, UC; CSU-GE:C1; GAV-GE:C1

Introduction to music fundamentals and keyboard technique. Development of beginning keyboard skills including note reading in bass and treble clef, fingering, rhythm, key signatures, primary chords and inversions. ADVISORY: Must be taken in sequence.

10672	L/L	OE01	Amirkhanian M	4.60	3.0	MW	0900A-1105A
-------	-----	------	---------------	------	-----	----	-------------

10674	L/L	OE01	Amirkhanian M	4.60	3.0	TR	0900A-1105A
-------	-----	------	---------------	------	-----	----	-------------

10979	Lec	OE01	Amirkhanian M	3.20	3.0	MW	1120A-1240P
-------	-----	------	---------------	------	-----	----	-------------

10676	L/L	OE01	Mello S	4.30	3.0	M	0530P-0935P
-------	-----	------	---------	------	-----	---	-------------

MUS 4B Beginning Piano

Transferable: CSU, UC; GAV-GE:C1

Continuation of Music 4A. ADVISORY: Music 4A

10680	L/L	OE01	Amirkhanian M	3.20	2.0	TR	1120A-1240P
-------	-----	------	---------------	------	-----	----	-------------

10681	L/L	OE01	Mello S	4.30	2.0	M	0530P-0935P
-------	-----	------	---------	------	-----	---	-------------

MUS 5A Intermediate Piano

Transferable: CSU, UC; GAV-GE:C1

Development of intermediate keyboard skills through means of scales, chords, and technical studies. Continuation of music fundamentals and beginning keyboard harmony; introduction of easier classical and standard piano literature. ADVISORY: Music 4B

10683	L/L	OE01	Amirkhanian M	3.20	2.0	TR	1120A-1240P
-------	-----	------	---------------	------	-----	----	-------------

10684	L/L	OE01	Mello S	4.00	2.0	M	0535P-0935P
-------	-----	------	---------	------	-----	---	-------------

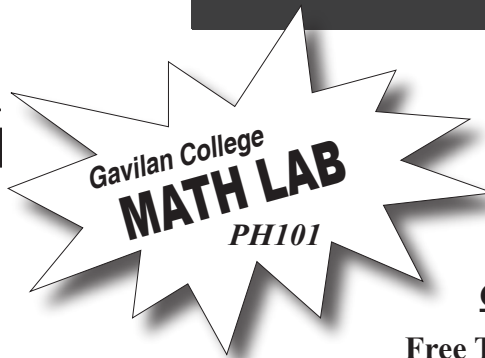

FREE TUTORING!

Services for Gavilan Students:

**Free Tutoring for MATH
Free Computer Assistance**

For daily schedule or for free Math downloads, check our website - <http://www.gavilan.edu/mathlab/>

Staffed by the Math Department



Gain eligibility for special scholarships and awards!

Meet other honors students!

(408) 846-4947

Serve the community!

Must have a GPA of at least 3.0 for twelve units.
Incoming freshmen with GPA of at least 3.5 in HS



Tutoring Center
www.gavilan.edu/tutor
408-848-4838
Located in LI 116



Free tutoring is available in a variety of subjects!

Work with a peer tutor and fellow students to develop a better understanding of course content.

Fall/Spring Semester:
Mon-Thurs: 8 am - 7:45 pm
Fri, 8 am - 4 pm

Summer Session: Call for hours

Debbie King, Tutoring Program Coordinator
Sara Spencer, Evening Tutoring Specialist

CRN Type Room Instructor Hrs. Units Days Begin-End

MUS 5B Intermediate Piano

Transferable: CSU, UC; GAV-GE:C1

Development of intermediate keyboard skills through means of scales, chords and technical studies. Continuation of music fundamentals and beginning keyboard harmony; introduction of easier classical and standard piano literature. ADVISORY: Music 5A

10685	L/L	OEO1	Amirkhanian M	3.20	2.0	TR	1120A-1240P
10686	L/L	OEO1	Mello S	4.30	2.0	M	0530P-0935P

MUS 5C Advanced Piano

Transferable: CSU, UC; GAV-GE:C1

Development of advanced keyboard skills through means of scales, chords and technical studies. Continuation of music fundamentals and keyboard harmony; introduction of moderately difficult classical and standard piano literature. ADVISORY: Music 5B

10688	L/L	OEO1	Amirkhanian M	3.20	2.0	TR	1120A-1240P
10689	L/L	OEO1	Mello S	4.30	2.0	M	0530P-0935P

MUS 5D Advanced Piano

Transferable: CSU, UC; GAV-GE:C1

Development of advanced keyboard skills through means of scales, chords and technical studies. Continuation of music fundamentals and keyboard harmony; introduction of moderately difficult classical and standard piano literature. ADVISORY: Music 5C

10691	L/L	OEO1	Amirkhanian M	3.20	2.0	TR	1120A-1240P
10692	L/L	OEO1	Mello S	4.30	2.0	M	0530P-0935P



MUS 6 Introduction to World Music

Transferable: CSU

This course explores a broad and diverse survey of different non Western music cultures, helping students develop listening skills to identify, distinguish and appreciate the elements and richness of each culture's music. The course will cover a rich diversity of styles through informed listening, analysis and discernment of musical elements, form and repertoire. Music of various cultures will be explored, for example: India, China, Japan, the Middle East, Indonesia, Africa, Europe and the Americas.

10667	Lec	PB5	Juncker A	3.20	3.0	MW	0945A-1105A
-------	-----	-----	-----------	------	-----	----	-------------

MUS 8A Beginning Voice

Transferable: CSU, UC; GAV-GE:C1

Development of techniques in the art of singing and interpreting serious music in various styles. Study of the basic techniques of tone production, breathing and related skills. Basic repertoire development. ADVISORY: Continues in sequence or by demonstrated proficiency.

10693	L/L	PB5	Pruitt N	3.20	2.0	TR	1120A-1240P
-------	-----	-----	----------	------	-----	----	-------------

MUS 8B Beginning Voice

Transferable: CSU, UC; GAV-GE:C1

Development of techniques in the art of singing and interpreting serious music in various styles. Study of the basic techniques of tone production, breathing and related skills. Basic repertoire development. ADVISORY: Music 8A or demonstrated proficiency.

10694	L/L	PB5	Pruitt N	3.20	2.0	TR	1120A-1240P
-------	-----	-----	----------	------	-----	----	-------------

MUS 8C Intermediate Voice

Transferable: CSU, UC; GAV-GE:C1

Development of techniques in the art of singing and interpreting serious music in various styles. Study of the basic techniques of tone production, breathing and related skills. Basic repertoire development. ADVISORY: Music 8B or demonstrated proficiency.

10695	L/L	PB5	Pruitt N	3.20	2.0	TR	1120A-1240P
-------	-----	-----	----------	------	-----	----	-------------

CRN Type Room Instructor Hrs. Units Days Begin-End

MUS 8D Intermediate Voice

Transferable: CSU, UC; GAV-GE:C1

Development of techniques in the art of singing and interpreting serious music in various styles. Study of the basic techniques of tone production, breathing and related skills. Basic repertoire development. ADVISORY: Music 8C or demonstrated proficiency.

10697	L/L	PB5	Pruitt N	3.20	2.0	TR	1120A-1240P
-------	-----	-----	----------	------	-----	----	-------------

MUS 9A Guitar

Transferable: CSU, UC; GAV-GE:C1

An introduction to playing the guitar. Basic staff notation, correct fingering and chord arpeggios are covered. Emphasis is also placed on developing musical listening skills. Students must provide their own guitars. May be repeated once for credit. ADVISORY: Students must provide their own guitars.

10698	Lab	PB5	Montoya T	3.30	1.0	M	0530P-0835P
-------	-----	-----	-----------	------	-----	---	-------------

MUS 9B Guitar

Transferable: CSU, UC; GAV-GE:C1

An introduction to playing the guitar. Basic staff notation, correct fingering and chord arpeggios are covered. Emphasis is also placed on developing musical listening skills. Students must provide their own guitars. May be repeated once for credit. ADVISORY: Music 9A; students must provide their own guitars.

10699	Lab	PB5	Montoya T	3.30	1.0	M	0600P-0905P
-------	-----	-----	-----------	------	-----	---	-------------

MUS 12 Vocal Ensemble

Transferable: CSU, UC; GAV-GE:C1

The day Vocal Ensemble will focus on individual and group performance of popular and alternative commercial music, and will rehearse and perform with a backup band. The evening Vocal Ensemble will study, rehearse and perform choral music in a broad spectrum of musical genre and styles. Included will be the study of vocal and rehearsal techniques as they relate to ensemble performance. Course may be repeated three times for credit.

10701	L/L	PB5	Juncker A	3.30	2.0	M	0130P-0435P
-------	-----	-----	-----------	------	-----	---	-------------

MUS 13 Concert Choir

Transferable: CSU, UC; GAV-GE:C1

The Concert Choir will study, rehearse and perform choral music from the 15th century to the present in a variety of musical styles with emphasis on the larger choral works and their preparation for public concert. Course may be repeated three times for credit. ADVISORY: Previous choral experience is preferred but not required. The student should have the ability to match a given pitch.

10702	L/L	GHS	Robb P	3.30	2.0	T	0600P-0905P
-------	-----	-----	--------	------	-----	---	-------------

This class meets in the choir room of Gilroy High School, 750 West Tenth St, Gilroy.

MUS 14A Instrumental Ensemble

Transferable: CSU; GAV-GE:C1

Instruction for the experienced musician with emphasis on the study and performance of a wide variety of musical styles from Renaissance to 20th century music for traditional ensembles, and extensive consideration of contemporary commercial and alternative repertoire, and performance techniques for popular ensembles.

10703	L/L	TH125	Marques A	3.30	2.0	M	0130P-0435P
10704	L/L	PB5	Quartuccio A	3.30	2.0	W	0600P-0905P

MUS 14B Instrumental Ensemble

Transferable: CSU; GAV-GE:C1

Instruction for the experienced musician with emphasis on the study and performance of a wide variety of musical styles from Renaissance to 20th century music for traditional ensembles, and extensive consideration of contemporary commercial and alternative repertoire, and performance techniques for popular ensembles.

10705	L/L	TH125	Marques A	3.30	2.0	M	0130P-0435P
10706	L/L	PB5	Quartuccio A	3.30	2.0	W	0600P-0905P

CRN Type Room Instructor Hrs. Units Days Begin-End

MUS 14C Instrumental Ensemble

Transferable: CSU; GAV-GE:C1

Instruction for the experienced musician with emphasis on the study and performance of a wide variety of musical styles from Renaissance to 20th century music for traditional ensembles, and extensive consideration of contemporary commercial and alternative repertoire, and performance techniques for popular ensembles.

10707	L/L	TH125	Marques A	3.30	2.0	M	0130P-0435P
10708	L/L	PB5	Quartuccio A	3.30	2.0	W	0600P-0905P

MUS 14D Instrumental Ensemble

Transferable: CSU; GAV-GE:C1

Instruction for the experienced musician with emphasis on the study and performance of a wide variety of musical styles from Renaissance to 20th century music for traditional ensembles, and extensive consideration of contemporary commercial and alternative repertoire, and performance techniques for popular ensembles.

10709	L/L	TH125	Marques A	3.30	2.0	M	0130P-0435P
10710	L/L	PB5	Quartuccio A	3.30	2.0	W	0600P-0905P

MUS 21 Electronic Music/Sound Design

Transferable: CSU; GAV-GE:C1

Fundamentals of electronic music synthesis using computers. Midi sequencing, digital sound processing, sampling, digital multi-track recording utilizing the college's state of the art midi studio. May be repeated three times for credit. ADVISORY: Eligible for English 250, 260 and Mathematics 205.

10711	L/L	LI128	Juncker A	3.20	3.0	TR	0810A-0930A
	ARR		Juncker A	2.30			

MUS 22 Field Work and Service

Transferable: CSU

Supervised field work within the college and with local agencies. Students serve in useful group activities in leadership roles prescribed for them by faculty or community agencies. A maximum of six units may be completed. This is a pass/no pass course. REQUIRED: Learning contracts must be filled out and signed by the student and the supervising instructor.

10712	Fld Ex		Robb P	3.30	1.0	T	0600P-0905P
This class meets in the choir room of Gilroy High School, 750 West Tenth Street, Gilroy.							
10713	Fld Ex	PB5	Quartuccio A	2.30	1.0	W	0700P-0905P

MUS 23 Independent Study

Transferable: CSU

Designed to afford selected students specialized opportunities for exploring areas at the independent study level. The courses may involve extensive library work, research in the community, or special projects. May be repeated until six units of credit are accrued. This course has the option of a letter grade or pass/no pass. REQUIRED: The study outline prepared by the student and the instructor must be filed with the department and the dean.

10714	Ind	PB11	Juncker A		1.0		
10715	Ind	PB11	Juncker A		2.0		
10716	Ind	PB5	Pruitt N		1.0		
10717	Ind	PB5	Pruitt N		2.0		
10718	Ind	PB5	Montoya T	2.30	1.0	M	0700P-0905P
10719	Ind		Robb P	2.30	1.0	T	0700P-0905P
This class meets in the choir room of Gilroy High School, 750 West Tenth St., Gilroy.							
10720	Ind	PB5	Quartuccio A	2.30	1.0	W	0700P-0905P

MUS 26 Symphony

Transferable: CSU, UC; GAV-GE:C1

Study and performance of orchestral literature. Individual and sectional skills development. Perform in public concerts each semester. May be repeated until a maximum of 8 units are accrued. ADVISORY: Demonstrated proficiency on individual's instrument and ability to read music.

10721	L/L	PB5	Quartuccio A	3.30	2.0	W	0600P-0905P
-------	-----	-----	--------------	------	-----	---	-------------



MUS 12 Vocal Ensemble

MUS 14A Instrumental Ensemble

- Play:
- Rock & Roll
- Jazz
- Blues
- Top Hits
- Classics
- Your original songs!

Arrange a personal tour!

Call 408-846-4993.

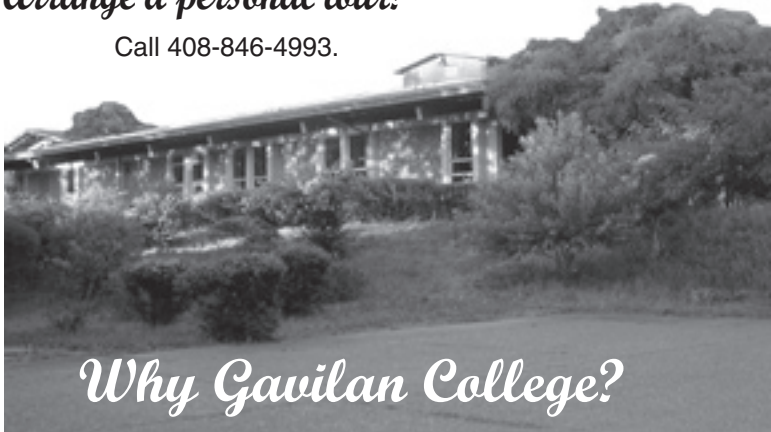

- Complete first two years of college coursework
- Easy transfer to UC, CSU and private universities
- Learn job skills
- Classes scheduled morning, afternoon and evening
- A variety of locations to serve your needs
- Excellent faculty/helpful staff
- Small classes
- Beautiful campus
- No Silicon Valley commute
- Close to home and work
- Affordable

CRN Type Room Instructor Hrs. Units Days Begin-End

MUS 98 Special Topics

Transferable: CSU; GAV-GE:C1

Special topics courses examine current problems or issues of interest to students within a specific discipline area. For topical content information, consult with appropriate department chairperson. For transfer status, check with a counselor. This course may have the option of a letter grade or pass/no pass.

10722	Lec	PB5	Quartuccio A	2.30	1.0	W	0700P-0905P
-------	-----	-----	--------------	------	-----	---	-------------

Nursing: see Allied Health

Nutrition: see Biological Sciences

Performing Arts: see Theatre Arts (THEA)

PHILOSOPHY

PHIL 2 Logic

Transferable: CSU, UC; CSU-GE:A3; GAV-GE:C2; CAN:PHIL6

Philosophy 2 is intended as a survey of the primary approaches to argumentation and what has been traditionally called 'correct' reasoning. Students will learn techniques of both deductive and inductive argumentation, basic symbolic logic, how to spot a fallacy, as well as how to apply these techniques to other aspects of their lives outside of the classroom. While logic is often quite formal, the goal is to see the practical application of this discipline. Students will become acquainted with the cultural variations to reasoning in addition to the standard Western focal approach. ADVISORY: Eligible for English 1A.

10723	Lec	SS210	Hodge E	3.20	3.0	MW	1120A-1240P
10724	Lec	PB7	Johnston M	3.30	3.0	T	0600P-0905P

PHIL 3A Ethics

Transferable: CSU, UC; CSU-GE:C2; IGETC:3B; GAV-GE:C2; CAN:PHIL4

Philosophy 3 is intended as a survey of the major areas and traditions of ethical and moral theories. The course examines central and significant questions about who determines what is morally right or wrong, the ideal society, the various notions social justice, moral agency and action in our lives and community, as well as many other topics. In pursuing these questions, students will be asked to read texts from writers around the world, both contemporary and ancient, discuss current events, and apply 'theory' to movies, novels, and any other relevant application of the student's own choice. ADVISORY: Eligible for English 1A.

10726	Lec	HOL1	Hodge E	3.20	3.0	TR	0945A-1105A
-------	-----	------	---------	------	-----	----	-------------

Above class meets at the Hollister Briggs site.

PHIL 4 Critical Thinking and Writing

Transferable: CSU, UC; CSU-GE:A3; IGETC:1B; GAV-GE:C2

This course is designed to introduce the relationship between critical thinking and critical writing in a way that will be both enjoyable to the student and helpful in other aspects of life. The student will learn techniques of critical thinking, paying close attention to the current events, movies and popular media, music lyrics, as well as the textbook. Students will learn to identify deductive and inductive arguments and be able to evaluate their strength, create a strong argument of their own on a given topic, as well become experts in the area of critical analysis. The goal is to enable students to become strong, well informed, articulate members of the community as well as individuals with an empowered sense of self as an agent of change. PREREQUISITE: English 1A

10727	Lec	PB7	Hodge E	3.20	3.0	MW	0945A-1105A
10728	Lec	HOL1	Hodge E	3.20	3.0	TR	0810A-0930A

Above class meets at the Hollister Briggs site.

What is a **CRN**?
 CRN stands for Course Reference Number.
 This is the number (used to be called section)
 that you will use to register for your classes.

CRN Type Room Instructor Hrs. Units Days Begin-End

PHIL 6A Comparative Religions

Transferable: CSU, UC; CSU-GE:C2; IGETC:3B; GAV-GE:F

Religion is a topic that ignites controversy -- most societies engage in religious practices, believe strongly in that tradition, and find a sense of identity within it. The controversy arises when differences are misunderstood, misrepresented, or placed in a hierarchy of assumed supremacy of one religion as superior to others. In this class, students explore the underlying commonality of various religious traditions, explore the uniqueness of the religions with which they are unfamiliar, and learn to see that diversity among beliefs doesn't have to create hostility. Students will explore religions from Indigenous Peoples throughout the world, East Asia (e.g. India), China, the Middle East, as well as some more recent trends in religion. ADVISORY: Eligible for English 1A.

10729	Lec	GHS-BE3	Grudzen G	3.30	3.0	T	0330P-0635P
-------	-----	---------	-----------	------	-----	---	-------------

Above class meets off-campus: This class is part of the High Step Program. It will be offered at Gilroy High School, room BE-3. This class is open to all students. For more information, see a Gavilan counselor.

PHIL 7A History of Philosophy: Ancient to Medieval Times

Transferable: CSU, UC; CSU-GE:C2; IGETC:3B; GAV-GE:C2

Philosophy 7A is a survey of the history of philosophy from the ancient to the medieval periods. It is a great class to take along with World History or a literature course. ADVISORY: Eligible for English 1A.

10730	Lec	PB12	Johnston M	3.20	3.0	TR	1250P-0210P
-------	-----	------	------------	------	-----	----	-------------

PHIL 12 Introduction to Political Thought

Transferable: CSU, UC; CSU-GE:D8; IGETC:4H; GAV-GE:D2

This course provides students with an introduction to and grounding in classical and modern political thought. Students will be introduced to theorists such as Plato, Aristotle, Machiavelli, and Marx. Students will also examine such timeless questions as: "What is justice?" "What is the good life?" and "What is power?" among others. This course is also listed as POLS 12.

10294	Lec	SS110	Hodge E	3.20	3.0	MW	1250P-0210P
-------	-----	-------	---------	------	-----	----	-------------

PHIL 23 Independent Study

Transferable: CSU

Designed to afford selected students specialized opportunities for exploring areas at the independent study level. The courses may involve extensive library work, research in the community, or special projects. May be repeated until six units of credit are accrued. This course has the option of a letter grade or pass/no pass. REQUIRED: The study outline prepared by the student and the instructor must be filed with the department and the dean.

10732	Ind	SS106	Hodge E		1.0		
-------	-----	-------	---------	--	-----	--	--

Photography: see Art, CSIS or Digital Media

PHYSICAL EDUCATION: ACADEMIC

PE 1 Orientation for Student-Athlete Success

Transferable: CSU; CSU-GE:E

This course identifies and clarifies issues relevant to student-athletes. Students will learn practical skills which will assist them in obtaining their educational objectives, such as proper use of library services, time management and test and note taking information.

10026	Lec	APE120/121	Lango J	7.20	1.0	MTWR	1130A-0100P
-------	-----	------------	---------	------	-----	------	-------------

08/14/08 - 08/28/08

PE 7 Theory of Sports Management

Transferable: CSU

This course introduces the theory of organizing, planning, directing and controlling a sports program. Areas such as budgeting, fundraising, advertising, marketing, and studying contract law will also be included.

10027	Lec	SS216	Andrade N	3.20	3.0	TR	0945A-1105A
-------	-----	-------	-----------	------	-----	----	-------------

Classroom Locations: Refer to "How to Use This Schedule" on page 6.

CRN Type Room Instructor Hrs. Units Days Begin-End

PE 10A Fundamentals of Softball

Transferable: CSU, UC

Basic theory, strategy, technique, practice and conditioning of softball to prepare the individual student in all aspects of playing and coaching the sport. May be repeated once for credit. This course has the option of a letter grade or pass/no pass.

10028 L/L GY131G Dequin N 3.80 2.0 TR 0230P-0415P

PE 10B Fundamentals of Softball

Transferable: CSU, UC

This course offers review and advanced instruction in the theory, strategies, and techniques of softball for the purposes of preparing the individual student in all aspects of playing and coaching the sport. May be repeated once for credit. This course has the option of a letter grade or pass/no pass. ADVISORY: PE 10A

10029 L/L GY131G Dequin N 3.80 2.0 TR 0230P-0415P

PE 11A Fundamentals of Baseball

Transferable: CSU, UC

Theory, strategy, technique, practice and conditioning of baseball to prepare the individual student in all aspects of playing and coaching the sport. May be repeated once for credit. This course has the option of a letter grade or pass/no pass.

10031 L/L GY131G Andrade N 5.60 2.0 MTWR 0230P-0340P

PE 11B Fundamentals of Baseball

Transferable: CSU, UC

This course offers review and advanced instruction in the theory, strategies, and techniques of baseball for the purpose of preparing the individual student in all aspects of playing and coaching the sport. May be repeated once for credit. This course has the option of a letter grade or pass/no pass. ADVISORY: Physical Education 11A.

10032 L/L GY131G Andrade N 5.60 2.0 MTWR 0230P-0340P

PE 12A Fundamentals of Football

Transferable: CSU, UC

Basic organization and administration of a football program involving equipment, practice schedules, personnel, conditioning, scouting, weight training, and football specific drills. May be repeated once for credit. This course has the option of a letter grade or pass/no pass.

10033 L/L APE120/121 Lango J 4.00 2.0 MTWR 0230P-0330P

PE 12B Fundamentals of Football

Transferable: CSU, UC

The administration and organization of a football program involving practice schedules, personnel, equipment, scouting, conditioning, weight training and football drills. May be repeated once for credit. This course has the option of a letter grade or pass/no pass. ADVISORY: Physical Education 12A.

10034 L/L APE120/121 Lango J 4.00 2.0 MTWR 0230P-0330P

PE 14A Fundamentals of Basketball

Transferable: CSU, UC; GAV-GE:E1

Basic theory, strategy, technique, practice, and conditioning involved in basketball to prepare the individual student in all aspects of playing and coaching the sport. May be repeated once for credit. This course has the option of a letter grade or pass/no pass.

10040 L/L APE120/121 Addison T 4.20 2.0 MW 0430P-0615P

PE 14B Fundamentals of Basketball

Transferable: CSU, UC; GAV-GE:E1

More in-depth and advanced instruction in the theory, strategy, practice, and conditioning in basketball to better prepare the individual student in all aspects of playing and coaching the sport. Designed for the student who has already completed PE 14A. May be repeated once for credit. This course has the option of a letter grade or pass/no pass. ADVISORY: PE 14A

10041 L/L APE120/121 Addison T 4.20 2.0 MW 0430P-0615P

Profile
FACULTY



Nikki Dequin
Head softball coach & Physical Education Instructor

I graduated from Gilroy High School in 1995. Upon graduating I, like many students wanted to get out of town. After attending De Anza College for 1 quarter, I realized how much wasted time I was spending commuting each day. I transferred to Gavilan College, where I played softball and finished my A.A degree in enough time to transfer into San Jose State the summer of 1997. My goal was to participate in intercollegiate athletics. With hard work I made the Division I softball program and my work ethic paid off when I was given a 5th year scholarship to complete my bachelors degree in Kinesiology. In 2001 after graduation I taught at Gilroy High School and coached softball at De Anza College, while working on my master's degree at San Jose St. The opportunity arose in 2005 to teach and coach here at Gavilan College and I knew this was where I was supposed to be. I had a great experience as a student athlete and was guided by some very caring and devoted instructors (some of whom are still here). I am fortunate to work with and learn from these people and truly enjoy sharing my experience with our current athletes. Our softball program has become highly recognized in the state of California, and my goal is to make it one of the top in the state.



The Computer Place Library 168

Services Available:

- Internet access ♦ Microsoft Office ♦
- Spanish software ♦ free printing in black and white ♦ minimal charge for color printing ♦ scanning ♦ transparencies

Mon-Thurs: 8 am - 5 pm
Fri: 8 am - 12 pm

Students should be aware that there are inherent risks involved in any physical exercise. Students are strongly advised to consult a physician prior to participating in any physical education activity.

CRN Type Room Instructor Hrs. Units Days Begin-End

PHYSICAL EDUCATION: ACTIVITIES

PE 16 Swimming

Transferable: CSU, UC; CSU-GE:E1; GAV-GE:E1

Coeducational activity designed for all skill levels. The course teaches the techniques of a variety of strokes and includes conditioning activities. Instruction is tailored to meet individual and group needs. May be repeated three times for credit. This course has the option of a letter grade or pass/no pass.

10044 Lab GY100P Dodd S 3.20 1.0 MW 1120A-1240P

PE 17 Golf

Transferable: CSU, UC; CSU-GE:E1; GAV-GE:E1

Coeducational activity designed for all skill levels; fundamentals, techniques, rules and etiquette of golf. May be repeated three times for credit. This course has the option of a letter grade or pass/no pass.

10956 Lab ERGOLF Krause S 3.00 .5 S 0900A-1155A
09/06/08 - 10/25/08 Short-term classes meet on specified dates. Class meets at Eagle Ridge Golf Club. A facility use fee will be charged. Details at first meeting.

10960 Lab GY200C Andrade N 3.00 1.0 F 1040A-0135P
A facility use fee will be charged. Details at the first meeting.

PE 18 Tennis

Transferable: CSU, UC; CSU-GE:E1; GAV-GE:E1

Coeducational activity stressing fundamentals of tennis such as forehand, backhand, serve and volley, along with the rules, etiquette and strategies of the game. May be repeated three times for credit. This course has the option of a letter grade or pass/no pass.

10067 Lab GY131G Kramer K 3.20 1.0 MW 1250P-0210P

PE 20 Bowling

Transferable: CSU, UC; CSU-GE:E1; GAV-GE:E1

Coeducational activity designed for beginning and intermediate bowlers; fundamentals and techniques of bowling. Scoring, bowling etiquette, terminology and team bowling are included. May be repeated three times for credit. This course has the option of a letter grade or pass/no pass.

10068 Lab GIBOWL Lango J 3.20 1.0 TR 0810A-0930A
Meets at Gilroy Bowl, 7554 Monterey Street, Gilroy. A facility use fee of \$1.50 per session is required.

PE 23 Independent Study

Transferable: CSU

Designed to afford selected students specialized opportunities for exploring areas at the independent study level. The courses may involve extensive library work, research in the community, or special projects. May be repeated until six units of credit are accrued. This course has the option of a letter grade or pass/no pass. REQUIRED: The study outline prepared by the student and the instructor must be filed with the department and the dean.

10070 ARR GY116 Dodd S 2.0

PE 24 Individualized Weight Training

Transferable: CSU, UC; CSU-GE:E1; GAV-GE:E1

An open laboratory for those who desire an individualized strength program using exercise machines and free weights. May be repeated three times for credit. This course has the option of a letter grade or pass/no pass.

10072 Lab GY123 Dodd S 1.0
Students should check in the first week of the semester at the Fitness Center (GY123) during lab hours (MWF:7 am-2 pm, TuTh:8 am-2 pm, M-Th evenings:4:30-6:30 pm).

10073 Lab GY123 Dodd S .5
Students should check in the first week of the semester at the Fitness Center (GY 123) during lab hours (MWF:7 am-2am, TuTh:8 am-2 pm, M-Th evenings, 4:30-6:30 pm).

PE Activities

Classes can be taken for letter grade or pass/no pass.

CRN Type Room Instructor Hrs. Units Days Begin-End

PE 39 Fencing

Transferable: CSU, UC; CSU-GE:E1; GAV-GE:E1

This course will explore the offensive and defensive fencing skills with a foil. May be repeated three times credit. This course has the option of a letter grade or pass/no pass.

10491 Lab APE101 DeCesare J 3.30 1.0 M 0600P-0905P
Equipment will be provided. A \$6.00 user fee will be charged payable to the instructor.

PE 44 Aerobics

Transferable: CSU, UC; CSU-GE:E1; GAV-GE:E1

A program of aerobic fitness. Includes various forms of exercise to improve health, heart, and body composition. May be repeated three times for credit. This course has the option of a letter grade or pass/no pass.

10074 Lab GY131G Dequin N 3.20 1.0 MW 1120A-1240P

PE 61 Swim for Fitness

Transferable: CSU, UC; CSU-GE:E1; GAV-GE:E1

Designed to develop endurance and swimming skills in order to maintain good cardiovascular/physical fitness. Intermediate swimming ability recommended. May be repeated three times for credit. This course has the option of a letter grade or pass/no pass.

10080 Lab GY100P Dodd S 3.20 .5 TR 0515P-0635P
09/04/08 - 10/23/08 Short-term classes meet on specified dates.

PE 62 Yoga

Transferable: CSU, UC; CSU-GE:E1; GAV-GE:E1

Co-educational activity designed for beginning yoga students. A program designed to improve flexibility and reduce stress, by learning a series of postures and focusing on proper breathing techniques. May be repeated three times for credit. This course has the option of a letter grade or pass/no pass.

10088 Lab APE101 Watson M 3.20 1.0 MW 1250P-0210P

10090 Lab MHG10/11 Watson M 3.20 1.0 MW 0500P-0620P
Above class meets at Morgan Hill Community site.

10093 Lab PHALL Muscari D 3.20 1.0 TR 0500P-0620P
Above class meets off-campus: Portuguese Hall, 695 Seventh St., Hollister.

PE 64 Individualized Cardiovascular Fitness

Transferable: CSU, UC; CSU-GE:E1; GAV-GE:E1

A fitness program which develops cardiovascular endurance through an individualized open lab format. May be repeated three times for credit. This course has the option of a letter grade or pass/no pass.

10162 Lab GY123 Dodd S 1.0
Students should check in the first week of the semester at the Fitness Center (GY123) during lab hours (MWF: 7 am-2 pm, TuTh: 8 am-2 pm, M-Th: evenings, 4:30-6:30 pm).

10167 Lab GY123 Dodd S .5
Students should check in the first week of the semester at the Fitness Center (GY 123) during lab hours (MWF: 7am-2 pm, TuTh: 8 am-2 pm, M-Th evenings: 4:30-6:30 pm).

PE 66 Dance Fundamentals

Transferable: CSU, UC; CSU-GE:E1; GAV-GE:E1

Designed to introduce and develop movement principles and skills necessary to perform modern dance and ballet. May also include jazz and/or tap dance. Emphasizes enjoyment of dance as a form of exercise and will include some conditioning. Basic choreography skills will be included. May be repeated three times for credit. This course has the option of a letter grade or pass/no pass.

10171 Lab APE101 Waggoner K 3.40 1.0 TR 1120A-1245P

PE 70 Pilates

Transferable: CSU, UC; CSU-GE:E1; GAV-GE:E1

This class utilizes the Pilates exercise system focused on improving flexibility and strength for the total body through a series of controlled movements. May be repeated three times for credit. This course has the option of a letter grade or pass/no pass.

10176 Lab APE101 Muscari D 3.20 1.0 TR 1250P-0210P

10180 Lab PHALL Muscari D 3.20 1.0 TR 0630P-0750P
Above class meets off-campus: Portuguese Hall, 695 Seventh St., Hollister.

CRN Type Room Instructor Hrs. Units Days Begin-End

PE 74 Hiking

Transferable: CSU, UC; CSU-GE:E1; GAV-GE:E1

Introduces the Santa Clara county parks, trails, and surrounding areas. Includes fun, challenging hikes which average 5-8 miles on moderate to steep terrain. May be repeated three times for credit. This course has the option of a letter grade or pass/no pass.

10500 Lab GY131G Dequin N 3.00 1.0 F 0810A-1100A

PE 75 Sports Conditioning

Transferable: CSU, UC; CSU-GE:E1; GAV-GE:E1

This activity class is designed to improve the physical condition of male and female athletes. It includes strength training, cardiovascular endurance, plyometric training, and sport specific techniques. May be repeated three times for credit. This course has the option of a letter grade or pass/no pass.

10507 Lab GY123 Dodd S .5
10506 Lab GY123 Dodd S 1.0

PHYSICAL EDUCATION: ADAPTED

PE 34 Adapted Aquatic Exercise

Transferable: CSU, UC; CSU-GE:E1; GAV-GE:E1

Designed to help individuals who by the nature of their disability such as wheelchair use, back injury, cardiovascular impairment, multiple sclerosis or other disabling condition require a specific aquatic exercise program that will contribute to their physical well-being. May be repeated as necessary based on measurable progress as documented in the student's educational contract. This course has the option of a letter grade or pass/no pass.

10218 Lab GY100P Ellis D 3.20 1.0 MW 0810A-0930A
10220 Lab GY100P Ellis D 3.20 1.0 TR 1120A-1240P
10223 Lab GY100P Ellis D 3.20 1.0 MW 1250P-0210P

PE 35 Adapted Swimming for Total Fitness

Transferable: CSU, UC; CSU-GE:E1; GAV-GE:E1

An individualized program of activities designed for students with physical disabilities to improve flexibility and range-of-motion, increase joint movement, improve circulation, and improve control of body movement through water adjustment and activities. Develops an appreciation of physical activity as a regular planned contribution to one's overall well-being. May be repeated as necessary based on measurable progress as documented in the student's educational contract. This course has the option of a letter grade or pass/no pass.

10224 Lab GY100P Ellis D 3.20 1.0 MW 0810A-0930A
10225 Lab GY100P Ellis D 3.20 1.0 TR 1120A-1240P
10226 Lab GY100P Ellis D 3.20 1.0 MW 1250P-0210P

PE 36 Adapted Physical Education

Transferable: CSU, UC; CSU-GE:E1; GAV-GE:E1

An individualized program of adaptive physical education activities designed to meet the needs of students with physical disabilities. Develops an appreciation of physical activity as a regular planned contribution to one's overall well-being. May be repeated as necessary based on measurable progress as documented in the student's educational contract. This course has the option of a letter grade or pass/no pass.

10227 Lab APE108 Ellis D 3.20 1.0 MW 0945A-1105A
10228 Lab APE108 Ellis D 3.20 1.0 TR 0945A-1105A
10229 Lab APE108 Ellis D 3.20 1.0 MW 1120A-1240P
10230 Lab APE108 Ellis D 3.20 1.0 TR 1250P-0210P

PE 38 Adapted Cardiovascular Conditioning & Training

Transferable: CSU, UC; CSU-GE:E1; GAV-GE:E1

Prescribed exercises in weight training, stretching and cardiovascular conditioning for those individuals that have been disabled through stroke, cardiovascular accident, arthritis, multiple sclerosis, or other condition. May be repeated as necessary based on measurable progress as documented in the student's educational contract. This course has the option of a letter grade or pass/no pass.

10231 Lab APE108 Ellis D 3.20 1.0 MW 0945A-1105A
10232 Lab APE108 Ellis D 3.20 1.0 TR 0945A-1105A
10233 Lab APE108 Ellis D 3.20 1.0 MW 1120A-1240P
10234 Lab APE108 Ellis D 3.20 1.0 TR 1250P-0210P

Fall Sports

- Football
- Men's Basketball
- Men's Soccer
- Women's Volleyball



Also check out the following Activity Classes...

- Aerobics
- Bowling
- Cardio Fitness
- Dance
- Fencing
- Golf
- Hiking
- Pilates
- Swimming
- Tennis
- Weight Training
- Yoga

Students wishing to participate in the intercollegiate athletic programs must be enrolled in and attending a minimum of 12 units during the first season of competition with a minimum of nine units applying towards a degree program.



GO RAMS!

For more information, contact the Athletic Department at 848-4876.

PE 24 Individualized Weight Training
PE 64 Cardiovascular Fitness

Fall Semester Fitness Center Lab Hours

Day	MWF	7:00 am - 2:00 pm
	TuTh	8:00 am - 2:00 pm
Eve.	MTuWTh	4:30 pm - 6:30 pm



- Section hours by arrangement
- ✦ 1.7 to 3.4 weekly hours
- ✦ .5 or 1.0 unit
- ✦ Fitness Center (GYM 123)

Open Lab Class Format
Designed for individualized strength or cardiovascular fitness programs in an open lab setting using a variety of exercise equipment.

Students should check in the first week of the semester during lab hours.

CRN	Type	Room	Instructor	Hrs.	Units	Days	Begin-End
-----	------	------	------------	------	-------	------	-----------

PE 534 Adapted Aquatic Exercise

Transferable: No

Designed to help individuals who by the nature of their disability such as wheelchair use, back injury, cardiovascular impairment, multiple sclerosis or other disabling condition require a specific aquatic exercise program that will contribute to their physical well being. May be repeated as necessary based on measurable progress as documented in the student's educational contract. This is a pass/no pass course.

10235	Lab	GY100P	Ellis D	3.20	1.0	MW	0810A-0930A
10265	Lab	GY100P	Ellis D	3.20	1.0	TR	1120A-1240P
10269	Lab	GY100P	Ellis D	3.20	1.0	MW	1250P-0210P

PE 535 Adapted Swimming for Total Fitness

Transferable: No

An individualized program of activities designed for students with physical disabilities to improve flexibility and range-of-motion, increase joint movement, improve circulation, and improve control of body movement through water adjustment and activities. Develops an appreciation of physical activity as a regular planned contribution to one's overall well-being. May be repeated as necessary based on measurable progress as documented in the student's educational contract. This course is pass/no pass.

10274	Lab	GY100P	Ellis D	3.20	1.0	MW	0810A-0930A
10287	Lab	GY100P	Ellis D	3.20	1.0	TR	1120A-1240P
10283	Lab	GY100P	Ellis D	3.20	1.0	MW	1250P-0210P

PE 536 Adapted Physical Education

Transferable: No

An individualized program of adaptive physical education activities designed to meet the needs of students with physical disabilities. Develops an appreciation of physical activity as a regular planned contribution to one's overall well-being. May be repeated as necessary based on measurable progress as documented in the student's educational contract. This is a pass/no pass course.

10290	Lab	LOADCS1	TBA	3.20	1.0	MW	0945A-1105A Above class meets at Live Oak Adult Day Care, 651 West Sixty Street, Gilroy.
10293	Lab	APE108	Ellis D	3.20	1.0	MW	0945A-1105A
10297	Lab	APE108	Ellis D	3.20	1.0	TR	0945A-1105A
10298	Lab	LOADCS1	Maringer J	3.30	1.0	F	0945A-1250P Above class meets at Live Oak Adult Day Care, 651 West Sixty Street, Gilroy.
10336	Lab	APE101	Ellis D	3.30	1.0	F	0945A-1250P
10300	Lab	APE108	Ellis D	3.20	1.0	MW	1120A-1240P
10305	Lab	HOLLCC1	TBA	3.20	1.0	MW	1120A-1240P Above class meets off-campus.
10332	Lab	APE108	Ellis D	3.20	1.0	TR	1250P-0210P

PE 538 Adapted Cardiovascular Conditioning & Training

Transferable: No

Prescribed exercises in weight training, stretching and cardiovascular conditioning for those individuals that have been disabled through stroke, cardiovascular accident, arthritis, multiple sclerosis, or other condition. May be repeated as necessary based on measurable progress as documented in the student's educational contract. This is a pass/no pass course.

10334	Lab	APE108	Ellis D	3.20	1.0	MW	0945A-1105A
10335	Lab	APE108	Ellis D	3.20	1.0	TR	0945A-1105A
10337	Lab	LOADCS1	TBA	3.20	1.0	TR	0945A-1105A Above class meets at Live Oak Adult Day Care, 651 West Sixth Street, Gilroy.
10338	Lab	APE108	Ellis D	3.20	1.0	MW	1120A-1240P
10339	Lab	APE108	Ellis D	3.20	1.0	TR	1250P-0210P



Appropriate footwear is required in all gym facilities. No barefeet permitted.

CRN	Type	Room	Instructor	Hrs.	Units	Days	Begin-End
-----	------	------	------------	------	-------	------	-----------

INTERCOLLEGIATE ATHLETICS**ATH 35 Basketball**

Transferable: CSU, UC; CSU-GE:E1; GAV-GE:E1

This course provides practice and competition in intercollegiate basketball. May be repeated three times for credit. This course has the option of a letter grade or pass/no pass.

10018	Lab	GY131G	Addison T	10.00	2.0	MTWRF	0230P-0430P
-------	-----	--------	-----------	-------	-----	-------	-------------

ATH 42 Football

Transferable: CSU, UC; CSU-GE:E1; GAV-GE:E1

This course provides practice and competition in intercollegiate football. May be repeated three times for credit. This course has the option of a letter grade or pass/no pass.

10020	Lab	GY131G	Lango J	10.00	2.0	MTWRF	0330P-0530P
-------	-----	--------	---------	-------	-----	-------	-------------

ATH 46 Volleyball

Transferable: CSU, UC; CSU-GE:E1; GAV-GE:E1

This course provides practice and competition in intercollegiate volleyball for women. May be repeated three times for credit. This course has the option of a letter grade or pass/no pass.

10022	Lab	GY131G	Kramer K	10.00	2.0	MTWRF	0430P-0630P
-------	-----	--------	----------	-------	-----	-------	-------------

ATH 47 Soccer

Transferable: CSU, UC; CSU-GE:E1; GAV-GE:E1

This course provides practice and competition in intercollegiate soccer. May be repeated three times for credit. This course has the option of a letter grade or pass/no pass.

10024	Lab	GY131G	Marques A	10.00	2.0	MTWRF	0230P-0430P
-------	-----	--------	-----------	-------	-----	-------	-------------

PHYSICAL SCIENCE**PSCI 1 Principles of Physical Science**

Transferable: CSU, UC; CSU-GE:B1; IGETC:5A; GAV-GE:B1

An introduction to the physical sciences for the non-science major. Attention is focused on fundamental laws of nature, their development and relation to the physical world. ADVISORY: Mathematics 205 and eligible for English 250 and 260.

10852	Lec	CH109	Snyder J	3.30	3.0	T	0600P-0905P
-------	-----	-------	----------	------	-----	---	-------------

PSCI 2 Introduction to Meteorology

Transferable: CSU, UC; CSU-GE:B1; IGETC:5A; GAV-GE:B1

An introductory course in Meteorology that is both descriptive and analytical on the physical principles affecting the earth's weather. Topics covered include the nature of the atmosphere, solar energy, heat, temperature, pressure, stability, moisture, wind, storms, severe weather and forecasting. The course introduces climatology as a scientific study and will look at the earth's climatic history, current research in climate modeling and the possibility of global climate change. ADVISORY: MATH 205.

10853	Online	N/A	Vantuyl A	3.0			
 This online class will be delivered entirely over the Internet. After enrolling, start the class by going to http://www.gavilan.edu/disted , and log into the system. Students who have not logged in by 5 pm on the 3rd day may be dropped from the class.							

PHYSICS**PHYS 1 Introduction to Physics**

Transferable: CSU, UC; CSU-GE:B3, B1; IGETC:5A; GAV-GE:B3, B1

This course is an introduction to the fundamental physical principles that control the world around us. Students will explore the fundamental principles of physics, their historical development, their application to everyday phenomena, and their impact upon political, social, and environmental issues. Laboratory exercises will explore the everyday world. ADVISORY: Mathematics 205.

10851	L/L	CH102	Lee R	6.60	4.0	TR	0945A-1250P
-------	-----	-------	-------	------	-----	----	-------------

Classroom Locations: Refer to "How to Use This Schedule" on page 6.

CRN Type Room Instructor Hrs. Units Days Begin-End

PHYS 2A General Physics

Transferable: CSU, UC; CSU-GE:B3, B1; IGETC:5A; GAV-GE:B3, B1; CAN:PHYS2, PHYS SEQ A

An introduction to the principles of physics using algebra and trigonometry. Topics include kinematics in one and two dimensions, vectors, equilibrium and non-equilibrium applications of Newton's Laws, work and energy, momentum, rotational kinematics and dynamics, simple harmonic motion, elasticity, thermal physics, thermodynamics, and waves. **PREREQUISITE:** MATH 8A or MATH 9. **ADVISORY:** Eligible for English 250 and English 260.

10911	Lec	CH102	Lee R	3.20	4.0	MW	1120A-1240P
	Lab	CH102	Lee R	2.30		W	0230P-0435P
	Lab	CH102	Lee R	1.00		F	1140A-1230P

Physiology: see Biological Sciences

POLITICAL SCIENCE

POLS 1 Introduction to American Government

Transferable: CSU, UC; CSU-GE:D8; IGETC:4H, 7A; GAV-GE:D2, D1; CAN:GOVT2

Explores the development of American political institutions and their utilization in dealing with issues arising at the international, national and state levels. Emphasis is placed on those problems which have defined our federal system of government. California government and appropriate state institutions will be included as a vital part of our federal system of government. **ADVISORY:** Eligible for English 250 and English 260.

10258 Online N/A Turetzky M 3.0
 This online class will be delivered entirely over the Internet. After enrolling, start the class by going to <http://www.gavilan.edu/disted>, and log into the system. Students who have not logged in by 5 pm on the 3rd day may be dropped from the class.

10268 Online N/A Turetzky M 3.0
 This online class will be delivered entirely over the Internet. After enrolling, start the class by going to <http://www.gavilan.edu/disted>, and log into the system. Students who have not logged in by 5 pm on the 3rd day may be dropped from the class.

10270 Lec SS210 Turetzky M 3.20 3.0 MW 0810A-0930A

10276 Lec SS210 Turetzky M 3.20 3.0 TR 0810A-0930A

10284 Lec MHG4 Kier D 3.20 3.0 TR 1120A-1240P
 Above class meets at Morgan Hill Community site.

10272 Lec SS210 Turetzky M 3.20 3.0 TR 0230P-0350P
 This service learning course section involves community work

10282 Lec SS210 Kier D 3.30 3.0 R 0600P-0905P

POLS 3 Introduction to Comparative Politics

Transferable: CSU, UC; CSU-GE:D8; IGETC:4H; GAV-GE:F

Comparative survey of political institutions and processes around the globe. Selected nations may include, but are not restricted to: the United Kingdom, France, Germany, Japan, Russia, India, Nigeria, and Mexico. **ADVISORY:** Eligible for English 250 and English 260.

10285 Lec SS210 Turetzky M 3.20 3.0 MW 0945A-1105A

POLS 4 Introduction to International Relations

Transferable: CSU, UC; CSU-GE:D8; IGETC:4H; GAV-GE:D2, F

This course provides an introduction to key contemporary international problems and the means to analyze them. Major parts of the course cover such topics as war and peace, foreign policymaking, the international economy, and future trends in world politics.

10289 Online N/A Turetzky M 3.0
 This online class will be delivered entirely over the Internet. After enrolling, start the class by going to <http://www.gavilan.edu/disted>, and log into the system. Students who have not logged in by 5 pm on the 3rd day may be dropped from the class.

POLS 12 Introduction to Political Thought

Transferable: CSU, UC; CSU-GE:D8; IGETC:4H; GAV-GE:D2

This course provides students with an introduction to and grounding in classical and modern political thought. Students will be introduced to theorists such as Plato, Aristotle, Machiavelli, and Marx. Students will also examine such timeless questions as: "What is justice?" "What is the good life?" and "What is power?" among others. This course is also listed as PHIL 12. Previously POLS 2.

10292 Lec SS110 Hodge E 3.20 3.0 MW 1250P-0210P

Profile
FACULTY

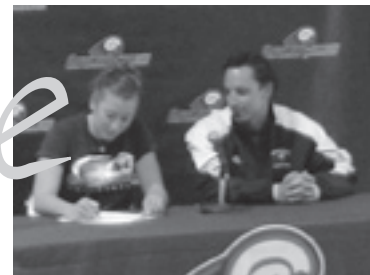

Alum Jamie Temperino signs a National Letter of Intent to play volleyball at East Carolina University in the fall.

Kevin Kramer

Kevin Kramer is in his second year as Gavilan's Head Women's Volleyball Coach. He spent two seasons as the Head Coach at Canada College in Redwood City, leading them to a 30-9 overall record and their first ever playoff appearance in 2006. In Gavilan's first year under Kramer, the team finished with a record of 12-9, and the first winning season since the program was re-established in 2005. This is Kevin's second year as a full time instructor at Gavilan after spending five years as a Physical Education, Health, and Psychology teacher at Mt. Eden High School in Hayward, CA. In 2001, Kevin graduated from U.C. Santa Barbara with a B.A. in Psychology and later completed his M.A. in Education and his Single Subject Teaching Credential in Physical Education from National University.

The Women's Volleyball Program focuses on the overall development of each student-athlete's physical, social, mental, and emotional skills, which will allow each student-athlete the greatest opportunity to reach their full potential on the court, in the classroom, and in all other aspects of life. In addition, it is the goal of Gavilan Volleyball to take the potential of each individual and blend it with the potential of other members of the program in order to create the most educational, competitive, and successful experience for all who are involved.

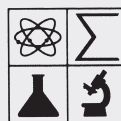

MATHEMATICS • ENGINEERING • SCIENCE ACHIEVEMENT

- ◆ Are you a math based major? (BIO, CSIS, Architecture, etc.)
- ◆ Do you want to transfer to a 4-year university?
- ◆ Do you have financial need? You may be eligible!

Gavilan's MESA Program is now accepting applications. MESA students are entitled to workshops, academic advising, field trips, tutoring and more!

For more information call 408-848-4887 or visit the MESA Study Center in PB16.

◆ www.gavilan.edu/MESA ◆

MATH • ENGINEERING • SCIENCE MAJORS

PLANNING TO TRANSFER?

Admission for these majors is very competitive

4-year universities stress preparation for the major over completion of general education major.

High-unit majors do not need to fulfill all general education requirements

You do not need to get an AA or AS degree to transfer

You should plan your sequential courses early.



can help you plan your courses to complete major preparation prior to transfer. Go to www.assist.org and see a counselor to develop an educational plan.

CRN Type Room Instructor Hrs. Units Days Begin-End

POLS 22 Field Work and Service

Transferable: CSU

Supervised field work within the college and with local agencies. Students serve in useful group activities in leadership roles prescribed for them by faculty or community agencies. A maximum of six units may be completed. This is a pass/no pass course. REQUIRED: Learning contracts must be filled out and signed by the student and the supervising instructor.

10319 Fld Ex SS107 Turetzky M 1.0
Above class meets off-campus.

POLS 23 Independent Study

Transferable: CSU

Designed to afford selected students specialized opportunities for exploring areas at the independent study level. The courses may involve extensive library work, research in the community, or special projects. May be repeated until six units of credit are accrued. This course has the option of a letter grade or pass/no pass. REQUIRED: The study outline prepared by the student and the instructor must be filed with the department and the dean.

10320 Ind SS107 Turetzky M 1.0
10321 Ind SS107 Turetzky M 2.0

POLS 27 Contemporary Leadership

Transferable: CSU; GAV-GE:E2

A cross-disciplinary approach to the theory and practice of leadership. Includes effective communication styles including issues related to gender and culture. Class includes topics on ethics, power, and how to run effective meetings including the use of parliamentary procedure. Skills directly applicable to work, personal and college environments. May be repeated for a maximum of 10 units. Also listed as PSYC 27. ADVISORY: Eligible for English 250 and English 260.

10035 L/L SC154N/S Stewart J 3.20 3.0 TR 0945A-1105A
ARR TBA 2.00

PSYCHOLOGY

PSYC 1A Introduction to Psychology

Transferable: CSU, UC; CSU-GE:D9; IGETC:4; GAV-GE:D2; CAN:PSY2

The nature, scope, methods, presuppositions, history, and fields of psychology together with the scientific study of factors influencing human behavior, human development, perception, learning, memory, emotion, personality, frustration, and psychotherapy. ADVISORY: Eligible for English 250 and English 260.

10322 Lec SS214 Oler C 3.20 3.0 MW 0810A-0930A
10323 Lec PB5 Campilli J 3.20 3.0 TR 0810A-0930A
10324 Lec HOL4 Oler C 3.20 3.0 MW 1120A-1240P
Above class meets at the Hollister Briggs site.
10325 Lec SS205 Campilli J 3.20 3.0 TR 1250P-0210P
10326 Lec SS214 Oler C 3.20 3.0 TR 0230P-0350P
10327 Lec HOL5 Oler C 3.30 3.0 R 0600P-0905P
Above class meets at the Hollister Briggs site.

PSYC 1B Introduction to Psychology

Transferable: CSU, UC; CSU-GE:D9; IGETC:4; GAV-GE:D2

Continuation of Psychology 1A. This course stresses the biological basis of behavior including: neuroanatomy, the senses, perception, learning, thinking, and psychological disorders. PREREQUISITE: Completion of Psychology 1A with a grade of 'C' or better.

10328 Lec SS210 Oler C 3.20 3.0 TR 1120A-1240P

Your educational plan:

You are expected to take the responsibility for scheduling an appointment with a counselor, preferably at least once a semester. The purpose of this appointment is to develop, review and update your educational plan to ensure that you are taking the appropriate courses to meet your educational goal.

CRN Type Room Instructor Hrs. Units Days Begin-End

PSYC 2 Early Child Development

Transferable: CSU, UC; CSU-GE:D9, E; IGETC:4; GAV-GE:D2

A systematic study of the child from prenatal life through the preschool years. The course integrates the basic concepts of physical, cognitive and psychosocial development at each major stage of life during this period. This course is also listed as CD 2. This course has the option of a letter grade or pass/no pass. ADVISORY: Eligible for English 250 and English 260.

10157 Lec MHG4 Bumgarner M 3.20 3.0 MW 0945A-1105A
Above class meets at Morgan Hill Community site.

10161 Lec HOL4 Muscari D 3.30 3.0 W 0600P-0905P
Above class meets at the Hollister Briggs site.

PSYC 3 Child Growth and Development During the School Years

Transferable: CSU, UC; CSU-GE:E; IGETC:4; GAV-GE:D2

Continuation of the study of child development with emphasis on children from six years of age through adolescence. Includes developmental theories and topics relevant to these ages. This course is also listed as CD 3. This course has the option of a letter grade or pass/no pass. ADVISORY: Eligible for English 250 and English 260; Psychology 2.

10973 Online N/A Bumgarner M 3.0
This online class will be delivered entirely over the Internet. After enrolling, start the class by going to <http://www.gavilan.edu/disted>, and log into the system. Students who have not logged in by 5 pm on the 3rd day may be dropped from the class.

PSYC 5 Self-Assessment and Career Development

Transferable: CSU; CSU-GE:E2; GAV-GE:E2

A course designed to assist the student in learning more about personal values, personality, interests, exploration of career choice, and occupational opportunities through the use of various personal assessment instruments. The delivery options for this course include online and self-paced formats. This course is also listed as GUID 1. ADVISORY: Eligible for English 250 and English 260. \$12 fee will be charged for career assessment materials.

10012 Lec APE120/121 Godley J 2.30 2.0 W 0810A-1015A
10015 Lec HOL1 Lopez A 2.30 2.0 W 0230P-0435P
Above class meets at the Hollister Briggs site.

10014 Lec SBHS-194 Caffiero J 2.30 2.0 M 0315P-0520P
This class is part of the High Step Program. It will be offered at San Benito County High School, room 194. This class is open to all students. For more information, see a Gavilan counselor.

10696 Lec CJ500 Godley J 2.30 2.0 R 1250P-0255P

10678 Online N/A Sharboneau R 2.0
This online class will be delivered entirely over the Internet. After enrolling, start the class by going to <http://www.gavilan.edu/disted>, and log into the system. Students who have not logged in by 5 pm on the 3rd day may be dropped from the class.

10700 Online N/A Sharboneau R 2.0
This online class will be delivered entirely over the Internet. After enrolling, start the class by going to <http://www.gavilan.edu/disted>, and log into the system. Students who have not logged in by 5 pm on the 3rd day may be dropped from the class.

PSYC 7 Cultural Context of Childhood

Transferable: CSU; CSU-GE:D7; GAV-GE:D2, F

This course examines cultural influences on child-rearing practices, family values, and human development. Perspectives from the social sciences will be used to explore what is common to all Homo sapiens and what is specific to the culture of the U.S. Students will explore their personal assumptions and attitudes towards diversity, and practice implementing non-stereotypical, developmentally appropriate, anti-bias activities, interactions, and environments in order to respond to and intervene against prejudice among children. This course is also listed as CD 7 and ANTH 9.

10169 Lec MHG4 Bumgarner M 3.20 3.0 MW 1120A-1240P
Above class meets at Morgan Hill Community site.

PSYC 22 Field Work and Service

Transferable: CSU

Supervised field work within the college and with local agencies. Students serve in useful group activities in leadership roles prescribed for them by faculty or community agencies. A maximum of six units may be completed. This is a pass/no pass course. REQUIRED: Learning contracts must be filled out and signed by the student and the supervising instructor.

10329 Fld Ex SS119 Hinn G 1.0

Classroom Locations: Refer to "How to Use This Schedule" on page 6.

CRN Type Room Instructor Hrs. Units Days Begin-End

PSYC 23 Independent Study

Transferable: CSU

Designed to afford selected students specialized opportunities for exploring areas at the independent study level. The courses may involve extensive library work, research in the community, or special projects. May be repeated until six units of credit are accrued. This course has the option of a letter grade or pass/no pass. REQUIRED: The study outline prepared by the student and the instructor must be filed with the department and the dean.

10330 Ind SS109 Oler C 2.0

PSYC 27 Contemporary Leadership

Transferable: CSU; GAV-GE:E2

A cross-disciplinary approach to the theory and practice of leadership. Includes effective communication styles including issues related to gender and culture. Class includes topics on ethics, power, and how to run effective meetings including the use of parliamentary procedure. Skills directly applicable to work, personal and college environments. May be repeated for a maximum of 10 units. Also listed as POLS 27. ADVISORY: Eligible for English 250 and English 260.

10036 L/L SC154N/S Stewart J 3.20 3.0 TR 0945A-1105A
ARR TBA 2.00

PSYC 41 Psychology of Adjustment

Transferable: CSU; CSU-GE:E2; GAV-GE:E2

Analysis of personal interactions, process of personal adjustment, frustration and defense mechanisms, assertive behavior, values clarification and the goals of individual behavior. ADVISORY: Eligible for English 250 and English 260.

10331 Lec SS110 Hinn G 3.20 2.0 TR 0945A-1105A

Public Speaking: see Communications

REAL ESTATE

RE 162 Real Estate Practice

Transferable: CSU

Introduction to the practice of real estate in California; emphasis on the practical application of listings, selling, advertising, financing, escrow, taxation, and valuation of real estate. This course meets a requirement for the California o credit.License. This course has the option of a letter grade or pass/no pass. May be repeated three times for credit. ADVISORY: Real Estate 160

10924 Lec BU120 Frimann G 6.60 3.0 TR 0630P-0935P
10/23/08 - 12/11/08

RE 165 Legal Aspects of Real Estate

Transferable: CSU

A study of California real estate law, including rights incident to property ownership and management, agency contracts, transfer of interest, liens and their foreclosure, encumbrances, and recent legislation relating to the foregoing. This course meets a requirement for the California Broker's License. This course has the option of a letter grade or pass/no pass. ADVISORY: Real Estate 160

10986 Online N/A Banks S 3.0

 This online class will be delivered entirely over the Internet. After enrolling, start the class by going to <http://www.gavilan.edu/disted>, and log into the system. Students who have not logged in by 5 pm on the 3rd day may be dropped from the class.

RE 167 Real Estate Economics

Transferable: CSU

An introduction to the causes and effects of value fluctuations in real estate, the nature of land economics and development of residential, commercial, industrial, recreational and special purpose properties. The student will study the principles of capitalism, community growth patterns, taxes, and other related economic concepts. This course may be used for the California Broker's License. This course has the option of a letter grade or pass/no pass. May be repeated three times for credit. ADVISORY: Real Estate 160

10925 Lec BU120 Frimann G 6.60 3.0 TR 0630P-0935P
09/04/08 - 10/21/08

Make a difference.
Your voice counts.

POLS 27 Contemporary Leadership

CRN# 10035 Tu/Th, 9:45 - 11:05 am, N/S Lounges

Also listed as PSYC 27

Albert Arnold (Al) Gore Jr. shared the 2007 Nobel Peace Prize with the Intergovernmental Panel on Climate Change (IPCC) of Geneva, Switzerland

ASB Associated Student Body

Today –
Shaping the policies of the college.

Tomorrow –
Shaping the policies of the world.

Join Student Government
(408) 848-4777

Beginning with the summer and fall 2008 enrollment period social security numbers will no longer be used as student identifiers. Find your new Gavilan Student ID and choose a log-on PIN by going to www.gavilan.edu and clicking on the Self-Service Banner icon. You will use your new ID and PIN to log into Self-Service Banner and register for summer and fall classes.

Campus under construction
ROOM NUMBERS MAY CHANGE!

Check room numbers online before your first class.

CRN	Type	Room	Instructor	Hrs.	Units	Days	Begin-End
Skin Care: see COS 220, 221							

SOCIOLOGY

SOC 1A Introduction to Sociology

Transferable: CSU, UC; CSU-GE:D0; IGETC:4J; GAV-GE:D2; CAN:SOC2

Analysis of the structure and dynamics of human society focusing on the development of culture, the socialization process, group behavior, social inequality, deviance, sexism, racism, and ageism, major social institutions, and human ecology. Emphasizes contemporary American society. ADVISORY: Eligible for English 250 and English 260.

10342	Lec	MHG10	Kreider R	3.20	3.0	MW	0945A-1105A
Above class meets at Morgan Hill Community site.							
10333	Lec	SS205	Kreider R	3.20	3.0	TR	0230P-0350P
10343	Lec	HOL1	Fault M	3.30	3.0	R	0600P-0905P
Above class meets at the Hollister Briggs site.							

SOC 1B Introduction to Sociology: Social Problems

Transferable: CSU, UC; CSU-GE:D0; IGETC:4J; GAV-GE:D2; CAN:SOC4

Sociology 1B is a course centering on the application of sociological concepts to the analysis of human ecology, social movements, social change, deviance and other selected social problems. Emphasis is placed on the study and analysis of problems in contemporary American society. ADVISORY: Sociology 1A

10349	Lec	SS205	Kreider R	3.20	3.0	MW	1250P-0210P
This service learning course section involves community work							
10352	Lec	SS210	Kreider R	3.20	3.0	TR	1250P-0210P
This service learning course section involves community work							

SOC 3 Sociology of Race, Ethnicity and Cultural Identity

Transferable: CSU, UC; CSU-GE:D0; IGETC:4J; GAV-GE:F

This course is designed to introduce students to the basic sociological concepts and theories of race, ethnicity and cultural identity in U.S. society. Students will examine race, ethnicity and cultural identity as social constructs that permeate social structures and institutions, and how they change over time and space. Over the semester students will critically analyze the ways which race, ethnicity, class, and gender/sexuality continually shape peoples lives and experiences. While the class focuses on U.S. societies, students will also critically compare and contrast race and ethnicity in other societies. ADVISORY: Eligible for English 250 and English 260.

10353	Lec	SS210	Cervantes E	3.20	3.0	TR	0945A-1105A
-------	-----	-------	-------------	------	-----	----	-------------

SOC 4 Sociology of Women and Men

Transferable: CSU, UC; CSU-GE:D4, D0; IGETC:4J; GAV-GE:D2

Analysis of the nature of women's and men's traditional and changing roles in society including development of women's and men's potential, relationships in marriage, influence of mass media, employment practices, legal provisions and women's and men's liberation. ADVISORY: Eligible for English 250 and English 260.

10356	Lec	SS206	TBA	3.20	3.0	MW	0230P-0350P
10355	Lec	SS210	Kreider R	3.30	3.0	R	0600P-0905P

SOC 10 Mass Media and Society

Transferable: CSU, UC; CSU-GE:D0, C2; IGETC:4J; GAV-GE:D2, C2

This course helps us understand the 20th century revolution in mass media by focusing on the history, economics and social impact of the newspaper, book publishing, magazine, film, television, public relations, advertising and music industries. We will study audience, propaganda and mass communication theory; we will discuss new technology, ethnic media in the U.S., ethical issues and attempts to regulate or control the media. Honors students will complete more in-depth analysis of media issues, and will finish a media-related research project. This course is also listed as JOUR 10. This course has the option of a letter grade or pass/no pass. ADVISORY: English 250, English 260

10358	Lec	PB7	TBA	3.20	3.0	MW	0810A-0930A
-------	-----	-----	-----	------	-----	----	-------------

CRN	Type	Room	Instructor	Hrs.	Units	Days	Begin-End
-----	------	------	------------	------	-------	------	-----------

SOC 21 Marriage and the Family

Transferable: CSU; CSU-GE:E2; GAV-GE:E2

Survey of information on preparation for marriage, including dating, courtship, engagement, mate selection, adjustment and parenthood. Time will also be spent on the study of families and how they function. ADVISORY: Eligible for English 250 and English 260.

10360	Lec	SS214	Hinn G	3.20	3.0	TR	0810A-0930A
10361	Lec	SS214	Fault M	3.30	3.0	T	0600P-0905P

SPANISH

SPAN 1A Elementary Spanish

Transferable: CSU, UC; CSU-GE:C2; GAV-GE:C2; CAN:SPAN2, SPAN SEQ A

Beginning course with emphasis on understanding and speaking Spanish; introduction to reading and writing Spanish. This course will also introduce students to Hispanic culture and institutions.

10735	L/L ARR	PB4	Marques A	5.20 2.8	5.0	MTWR	0810A-0915A
10733	L/L ARR	HOL5	Perez D	5.20 2.8	5.0	MTWR	0945A-1050A
Above class meets at the Hollister Briggs site.							
10981	Lec ARR	PB4	Marques A	5.20 2.8	5.0	MTWR	0945A-1050A
10736	L/L ARR	PB4	Perez D	5.20 2.8	5.0	MTWR	1250P-0155P
10980	Lec ARR	PB4	TBA	5.20 2.8	5.0	MTWR	0230P-0335P

SPAN 1B Elementary Spanish

Transferable: CSU, UC; CSU-GE:C2; IGETC:6A; GAV-GE:C2; CAN:SPAN4, SPAN SEQ A

Continuation of Spanish 1A. Further development of the four skills of understanding, speaking, reading and writing Spanish. This course will continue to emphasize the study of Hispanic culture and institutions. ADVISORY: Spanish 1A or equivalent.

10738	L/L ARR	HOL5	Perez D	5.20 2.8	5.0	MTWR	0830A-0935A
Above class meets at the Hollister Briggs site.							
10737	L/L ARR	PB4	Marques A	5.20 2.8	5.0	MTWR	1120A-1225P

SPAN 2A Intermediate Spanish

Transferable: CSU, UC; CSU-GE:C2; IGETC:3B, 6A; GAV-GE:C2; CAN:SPAN8, SPAN SEQ B

Review of basic structures through conversation and selected works of literature. Further expansion of patterns, vocabulary and idioms. Creative expression through discussion and composition. ADVISORY: Spanish 1B or equivalent.

10739	L/L ARR	SS110	Perez D	5.20 2.8	5.0	MTWR	1120A-1225P
-------	------------	-------	---------	-------------	-----	------	-------------

SPAN 8A Conversational Spanish

Transferable: CSU; GAV-GE:C2

This course is a beginning Spanish course, focusing on the Spanish sound system, basic grammar and vocabulary, and cultural elements. Although emphasis is on listening and speaking, basic reading and writing skills will be developed.

10740	Lec	HOL5	Polo I	3.30	3.0	M	0600P-0905P
Above class meets at the Hollister Briggs site.							

SPAN 8B Conversational Spanish

Transferable: CSU; GAV-GE:C2

This course requires knowledge of Spanish pronunciation, basic vocabulary, and present tense grammar. More advanced grammar and vocabulary, and cultural elements will be taught in the development of listening, speaking, basic reading and writing skills. ADVISORY: Spanish 8A or equivalent.

10741	Lec	MHG11	Lemos C	3.00	3.0	M	0635P-0935P
Above class meets at Morgan Hill Community site.							

Classroom Locations: Refer to "How to Use This Schedule" on page 6.

CRN Type Room Instructor Hrs. Units Days Begin-End

SPAN 8D Conversational Spanish

Transferable: CSU; GAV-GE: C2

This course requires fluency in spoken and written Spanish. Advanced grammar and vocabulary will be presented while the course concentrates on polishing the student's oral and written skills and develops a sense of style. ADVISORY: Spanish 8C or equivalent.

11015 Lec PB4 Lemos C 3.30 3.0 W 0630P-0935P

SPAN 12A Spanish for Spanish Speakers

Transferable: CSU, UC; CSU-GE:C2; IGETC:6A; GAV-GE:F

Through comparative analysis of selected literary works, the course develops an awareness of cultural and literary contributions from Mexico and other Spanish speaking societies. The course is taught in Spanish with emphasis on composition as a medium of expression. ADVISORY: Basic Spanish reading and writing skills.

10742 Online N/A TBA 5.0

This online class will be delivered entirely over the Internet. After enrolling, start the class by going to <http://www.gavilan.edu/disted>, and log into the system. Students who have not logged in by 5 pm on the 3rd day may be dropped from the class.

SPAN 23 Independent Study

Transferable: CSU

Designed to afford selected students specialized opportunities for exploring areas at the independent study level. The courses may involve extensive library work, research in the community, or special projects. May be repeated until six units of credit are accrued. This course has the option of a letter grade or pass/no pass. REQUIRED: The study outline prepared by the student and the instructor must be filed with the department and the dean.

10743 Ind PB11 Marques A 1.0
 10745 Ind PB4 Perez D 1.0
 10744 Ind PB11 Marques A 2.0
 10746 Ind PB11 Perez D 2.0

Speech: see Communications,
 Statistics: see Mathematics

THEATRE ARTS / DRAMA / TELEVISION

THEA 1 Theatre History

Transferable: CSU, UC; CSU-GE:C1; IGETC:3A; GAV-GE:C2, F

A survey of the history of theatrical performance, production and dramatic literature, including: early Greek, Roman, Asian, the Renaissance, Italian, English, modern European to contemporary American theatre. ADVISORY: Eligible for English 250 and English 260.

10747 Lec TH125 Lawton-Haehl J 3.20 3.0 MW 0945A-1105A

THEA 2A Children's Theatre Repertory

Transferable: CSU; GAV-GE:C1

This course focuses on formal dramatic presentations for child audiences. Activities will include acting, set design, costuming and makeup. ADVISORY: None. May be taken out of sequence.

10748 L/L TH125 Lawton-Haehl J 4.60 2.0 TR 0900A-1105A

THEA 2B Children's Theatre Repertory

Transferable: CSU; GAV-GE:C1

Preparation and performance of touring plays for young audiences. Special activities in creative dramatization, improvisation and script development will be studied. ADVISORY: None. May be taken out of sequence.

10749 L/L TH125 Lawton-Haehl J 4.60 2.0 TR 0900A-1105A

Beginning with the summer 2008 enrollment period, social security numbers will no longer be used as student identifiers. Find your new Gavilan Student ID and choose a log-on PIN by going to www.gavilan.edu and clicking on the Self-Service Banner icon. You will use your new ID and PIN to log into Self-Service Banner and register for summer and fall classes.



THEA 1 Theatre History

Learn about major artistic and cultural movements, read plays and texts from a variety of periods and analyze films of the historic texts in this exciting face-to-face class.

THEA 1 satisfies the ARTS requirement under the CSU-GE (Area C-1), the IGETC (Area 3A) and the AA/AS (Area C-1) Degree patterns.



Delight and perform educational shows for young audiences!

THEA 2A/B CHILDREN'S THEATRE REPERTORY

THEA 2A satisfies the Arts requirement (area C-1) of the GE-CSU and the Gavilan AA/AS Degree patterns. Use either as UC electives.

This semester we will be creating our own adaptation of stories from Grimm's Fairy Tales!

Rehearsals on Tuesdays and Thursdays: 9:00 - 11:05 am
 Educational performances on Thursday and Friday beginning in November
 Everyone is welcome! For more information, go to www.gavilan.edu/theatre

THEA 3

el teatro campesino

See live Theatrical productions at the Playhouse in San Juan Bautista!

Instructor: Marilyn Abad-Cardinalli
 Oct. 15 - Dec. 20

Broadcast Television Certificate of Proficiency



- THEA 14 Stage Production 2 units
- THEA 16 Introduction to Television 3 units
- THEA 17A Television and Video Workshop 3 units
- THEA 17B Television and Video Workshop 3 units
- THEA 19 Television and Film Acting 3 units

Choose one of the following courses:

- THEA 6 Introduction to Audio Production (3 units)
- THEA 20 Introduction to Scriptwriting (3 units)

..... 3 units
 Total Units for Certificate of Achievement: 17 UNITS

CRN Type Room Instructor Hrs. Units Days Begin-End

THEA 3 El Teatro Campesino

Transferable: CSU, UC; CSU-GE:C1; IGETC:3A; GAV-GE:C1

Reading, viewing and discussing the work of writer/director Luis Valdez and El Teatro Campesino (The Farmworkers Theatre) is the focus of this course. It traces the historical development of the theatrical company from its creation in 1965 to the present. Students will read actos, plays and view theatrical productions performed by El Teatro Campesino. This course has the option of a letter grade or pass/no pass. ADVISORY: Eligible for English 250 and English 260.

10750 Online N/A Gonzalez R 3.0
 10/15/08 - 12/20/08 This HYBRID lecture/online class will be delivered partially over the Internet. See the online syllabus for details. <http://www.gavilan.edu/disted/>

THEA 4 Oral Reading

Transferable: CSU, UC; CSU-GE:C1; GAV-GE:C1

An introduction to the analysis, preparation and dramatic reading of literature, including classical and contemporary prose, poetry and drama. Students prepare, analyze and orally present and interpret great works of drama and literature for an audience. This course is also listed as CMUN 2. ADVISORY: Eligible for English 250 and English 260.

10751 Lec TH125 Lawton-Haehl J 3.20 3.0 TR 1120A-1240P

THEA 12A Acting: History and Practice

Transferable: CSU, UC; CSU-GE:C1; GAV-GE:C1; CAN:DRAM8

An introduction to the historical development of acting as a practice of human cultural expression. Students will acquire a vocabulary for theatre performance as an art form and analyze dramatic works in a historical context. Practice of basic acting concepts, character analysis, preparation and performances of monologues and scenes will be required in the course.

10752 L/L TH125 Lawton-Haehl J 5.40 3.0 MW 1120A-0125P
 ARR 1.0

THEA 12B Acting Techniques

Transferable: CSU, UC; GAV-GE:C1

Techniques for creating characterizations for performance. Various acting approaches will be examined through research, discussion and acting exercises. This course has the option of a letter grade or pass/no pass. May be repeated two times for credit. ADVISORY: Theatre Arts 12A.

10753 L/L TH125 Lawton-Haehl J 4.60 2.0 MW 1120A-0125P

THEA 14 Stage Production

Transferable: CSU, UC; GAV-GE:C1

An individualized course in technical theatre production for the performing arts. Areas of study include: scenery, lighting, props, costumes, sound, make-up, public relations/box office management or stage management. May be repeated until a maximum of 9 units are accrued. ADVISORY: Eligible for English 250 and English 260.

10754 Lab TH125 Klipstine W 6.60 3.0 TR 1250P-0355P

10755 Lab TH125 Klipstine W 6.60 2.0 TR 1250P-0355P

10756 Lab TH125 Lawton-Haehl J 3.60 1.0 TR 1250P-0220P

THEA 16 Television History and Practice

Transferable: CSU; GAV-GE:C1

A history of the development of television technology and programming as a mass communications tool. Students study various approaches and methods in writing, programming and producing for television. This course is also listed as MCTV 16. ADVISORY: Eligible for English 250 and 260.

10757 Lec LI140 Abad M 3.20 3.0 MW 1120A-1240P

THEA 17A Television and Video Workshop

Transferable: CSU; GAV-GE:C1

An introduction to television and video technology, including pre-production, production and post-production techniques such as: camera work, studio equipment, lighting, audio plus off-line and on-line editing. This course is also listed as MCTV 16. ADVISORY: Theatre Arts 16 Intro to TV or consent of instructor.

10758 Lec LI140 Frazier J 5.40 3.0 TR 1250P-0315P

CRN Type Room Instructor Hrs. Units Days Begin-End

THEA 17B Television and Video Workshop

Transferable: CSU; GAV-GE:C1

Emphasis placed on production and post-production techniques in video production. Student knowledge and skills are increased by participating in live to tape projects. May be repeated twice for credit. This course is also listed as MCTV 17B. ADVISORY: Completion of Theatre Arts 17A.

10759 Lec LI140 Frazier J 5.40 3.0 TR 1250P-0315P

THEA 19 Television and Film Acting

Transferable: CSU, UC; GAV-GE:C1

Theory and practice of acting for film and television. Students will learn basic performance techniques for the camera. Learning experiences include projects in broadcasting, reporting, commercials, public service announcements (psa), comedy and drama. This course has the option of a letter grade or pass/no pass. May be repeated three times for credit. This course is also listed as MCTV 19.

10941 L/L LI140 Abad M 3.20 3.0 TR 1120A-1240P
 Gonzalez R

THEA 20 Introduction to Scriptwriting

Transferable: CSU; CSU-GE:C1

An introductory course on script development, writing and formatting for broadcast television and film production. This course has the option of a letter grade or pass/no pass. May be repeated three times for credit. ADVISORY: English 250

10760 Online N/A Gonzalez R 3.0
 10/15/08 - 12/20/08 This online class will be delivered entirely over the Internet. After enrolling, start the class by going to <http://www.gavilan.edu/disted/>, and log into the system. Students who have not logged in by 5 pm on the 3rd day may be dropped from the class.

THEA 22 Field Work and Service

Transferable: CSU

Supervised field work within the college and with local agencies. Students serve in useful group activities in leadership roles prescribed for them by faculty or community agencies. A maximum of six units may be completed. This is a pass/no pass course. REQUIRED: Learning contracts must be filled out and signed by the student and the supervising instructor.

10761 Fld Ex LI140 Abad M .5

10762 Fld Ex TH125 TBA .5

10763 Fld Ex LI140 TBA .5

10764 Fld Ex TH125 TBA .5

THEA 23 Independent Study

Transferable: CSU

Designed to afford selected students specialized opportunities for exploring areas at the independent study level. The courses may involve extensive library work, research in the community, or special projects. May be repeated until six units of credit are accrued. This course has the option of a letter grade or pass/no pass. REQUIRED: The study outline prepared by the student and the instructor must be filed with the department and the dean.

10769 Ind TH125 Lawton-Haehl J 1.0

10767 Ind LI140 Frazier J 1.0

10765 Ind TH125 Abad M 2.0

10766 Ind TH125 Abad M 2.0

10768 Ind LI140 Frazier J 2.0

10770 Ind TH125 Lawton-Haehl J 2.0

THEA 98 Special Topics

Transferable: CSU

Special topics courses examine current problems or issues of interest to students within a specific discipline area. For topical content information, consult with the appropriate department chairperson. For transfer status, check with a counselor. This course may have the option of a letter grade or pass/no pass.

10771 Lec LI140 Abad M 2.30 1.0 T 1120A-0125P

10772 Lec LI140 Abad M 3.30 3.0 T 1120A-0225P

CRN Type Room Instructor Hrs. Units Days Begin-End

VOCATIONAL PREP STUDENTS: DISABILITY

AE 600 Vocational Training I

Transferable: No

Prevocational skills for adults with impaired cognitive functioning. Entry level work preparation is emphasized. Skills taught include basic work routine orientation, communication skills, job ability assessment, and self-management skills.

10363	Lab	HOPEG	Merrill T			
Above class meets off-campus at HOPE Workshop, 8855 Murray Avenue, Gilroy.						
10351	Lab	HOPEH	Brown C			
Above class meets off-campus at HOPE Workshop, 2300 Technology Parkway, Hollister.						
10357	Lab	LI204	Franklin L			
10366	Lab	LI171	Sato K	2.00	TR	0910A-1000A
10367	Lab	LI117	Merrill T	7.00	W	0910A-0400P
10365	Lab	MHG3	Merrill T	4.30	M	0945A-0150P
Above class meets off-campus:						
10368	Lab	GY131G	Sato K	2.00	TR	1010A-1110A
10369	Lab	APE120/121	Brown C	3.20	TR	1120A-1240P

AE 602 Vocational Training III

Transferable: No

Practical training and on-the-job work experience for students with disabilities. This course also provides preparation for entry level employment utilizing a number of work alternatives and settings.

10370	Lab	HOPEG	Merrill T			
Above class meets off-campus: HOPE Workshop, 8855 Murray Avenue, Gilroy.						
10371	Lab	HOPEH	Sato K			
Above class meets off-campus at HOPE Workshop, 2300 Technology Parkway, Hollister.						
10372	Lab	LI204	Franklin L			

AE 603 Vocational Training IV

Transferable: No

AE 603 is a job readiness course which provides opportunities for individuals with disabilities to participate in service-learning activities and job readiness training leading to job development and placement in a community setting.

10373	Lab	LI204	Franklin L	3.30	W	0945A-1250P
10377	Lab	MHG8	Merrill T	3.30	F	0945A-1250P
Above class meets at Morgan Hill Community site.						

AE 605 Vocational Training VI

Transferable: No

This course is designed for students with disabilities. The purpose of this course is to improve the student's ability to participate in the community, by increasing independence through acquisition of survival vocabulary, structured practice in functional reading utilizing phonics and content recognition, and increased enjoyment in reading for pleasure. Opportunities will be provided for oral reading of high interest-low reading level life experience stories written or revised specifically for adults with limited reading skills.

10381	L/L	BU117	Brown C	1.60	R	1250P-0210P
-------	-----	-------	---------	------	---	-------------

AE 613 Independence Training IV

Transferable: No

This course is designed for students with disabilities. The purpose of this course is to improve the student's ability to build math competencies related to independence in daily living and the work site. The focus of the class is basic computation, consumer awareness, money management, banking and purchasing.

10384	L/L	BU117	Brown C	1.60	T	1250P-0210P
-------	-----	-------	---------	------	---	-------------

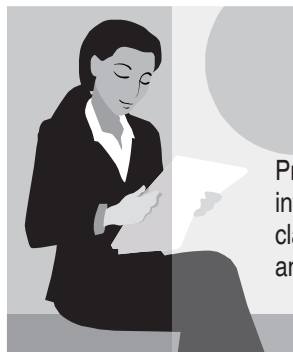

also listed as CMUN 2

THEA 4 3 units
Oral Reading

Instructor: Dr. John Lawton-Haehl

Prepare, analyze and orally present and interpret great works of drama including classical and contemporary prose, poetry and drama and literature for an audience!

Satisfies the Arts requirement (Area C-1) of the GE-CSU and the Gavilan AA/AS Degree. Use as a UC elective.



The Gavilan Educational Station

Be a part of the cameras, lights, action!



THEA 98 - GAVTV 18

INTERESTED? CHECK OUT OUR WEBSITE:
<http://www.gavilan.edu/gavtv/index.html>

Join us!

Monday evenings for the

Monday Night Series

6:30 p.m.

Gavilan College Theater

FREE!!



Staged Readings of Scripts,
Plays and Literature!

Presented by Gavilan Theatre Arts

Check the Theater Department Website
for play titles and dates.

Retail Management Certificate Coming Soon! (pending approval)



The certificate is composed of ten courses which may be offered in a combination of face to face and distance learning formats. Topics include:

- Principles of Marketing
- Introduction to Supervision
- Management Techniques
- Human Resources Management
- Leadership/Human Relations in Business



MKTG 100 - Principles of Marketing is the first course in the certificate.

CRN	Day	Time	Room
10934	Wed.	6:30 - 9:35 pm	BU120

Contact the office of Technical and Public Services at 408-848-4719 for additional information.



**Faculty! Staff! Students!
Working Parents! Community!**



Gavilan College has the only accredited child care facility in Gilroy!

NAEYC #430703716 & #434400444

FEE-BASED SERVICE

**6 wks - 5 yrs
6:30 am - 6:00 pm**

HALF-DAY PROGRAM Parents do not have to be students!

Call the Child Development Center at 408-848-4815 for more information.

Gavilan's Child Development Center will accept payment from other subsidized programs (i.e., 4C's, Choices for Children) Personal payment also accepted.

CRN Type Room Instructor Hrs. Units Days Begin-End

AE 636 Adapted Physical Education

Transferable: No

An individualized program of adapted physical education activities designed to meet the needs of students who are physically limited or disabled. The course assists in the development and appreciation of physical activity as a regular planned contribution to one's overall well-being. This course is for the non-matriculating student, is not graded and is without college credit. ADVISORY: Students must be able to document a physical disability.

10385	Lab	GY100P	Ellis D			
10387	Lab	LOADCS1	TBA	3.20	MW	0945A-1105A
Above class meets off-campus:						
10388	Lab	LOADCS1	TBA	3.20	TR	0945A-1105A
Above class meets off-campus:						
10391	Lab	LOADCS1	Maringer J	3.30	F	0945A-1250P
Above class meets off-campus:						
10403	Lab	APE101	Ellis D	3.30	F	0945A-1250P
10394	Lab	HOLLCC1	TBA	3.20	MW	1120A-1240P
Above class meets off-campus:						

Word Processing: see CSIS

WORK EXPERIENCE

CWE 190 Occupational Work Experience

Transferable: CSU

Occupational work experience for students who have a job related to their major. A training plan is developed cooperatively between the employer, college and student. (CR/NC grading) 75 hours per semester paid work = 1 unit. 60 hours non-paid (volunteer) work per semester = 1 unit. May be taken for a maximum total of 16 units. REQUIRED: Declared vocational major. Concurrent enrollment in seven or more units (including CWE units, except for summer school. For summer school, enrollment in one other class is required). Minimum 2.00 G.P.A.

Mandatory course orientation for the following classes will be conducted Tuesday evening, September 23rd from 5:30-6:30 pm in BU117, Wednesday, Sept. 24th or Thursday Sept. 25th, from 12-1 p.m. in SC 154N. Students need to attend one of the three meetings. Please contact Lynda Kerr, CWE Coordinator at (408) 846-4993 for more information.

10125	Wrk Ex	BU125	Kerr L	1.0
10126	Wrk Ex	BU125	Kerr L	2.0
10127	Wrk Ex	BU125	Kerr L	3.0
10128	Wrk Ex	BU125	Kerr L	4.0

CWE 192 General Work Experience Education

Transferable: CSU

General work experience for students who have a job unrelated to their major. General work experience is supervised employment which is intended to assist students in acquiring desirable work habits, attitudes and career awareness. A training plan is developed cooperatively between the employer, college and student. (CR/NC grading) 75 hours per semester paid work = 1 unit. 60 hours non-paid (volunteer) work per semester = 1 unit. May be taken for a maximum of 16 units. REQUIRED: Concurrent enrollment in seven or more units (including CWE units, except for summer school. For summer school, enrollment in one other class is required) Minimum 2.00 G.P.A.

Mandatory course orientation for the following classes will be conducted Tuesday evening, September 23rd from 5:30-6:30 pm in BU117, Wednesday, Sept. 24th or Thursday Sept. 25th, from 12-1 p.m. in SC 154N. Students need to attend one of the three meetings. Please contact Lynda Kerr, CWE Coordinator at (408) 846-4993 for more information.

10129	Wrk Ex	BU125	Kerr L	1.0
10130	Wrk Ex	BU125	Kerr L	2.0
10131	Wrk Ex	BU125	Kerr L	3.0

Classroom Locations: Refer to "How to Use This Schedule" on page 6.

NONCREDIT PROGRAM

This program is open to all students and currently offers various classes of interest to the community. All classes are free of charge.* There are no tests, no quizzes and no letter grades. Registration will take place in the Admissions & Records Office or on the first day of class. Students should contact Michelle Lopez in the Noncredit Office directly with any questions or for further information at (408) 848-4859.

* Some classes may require a materials fee.

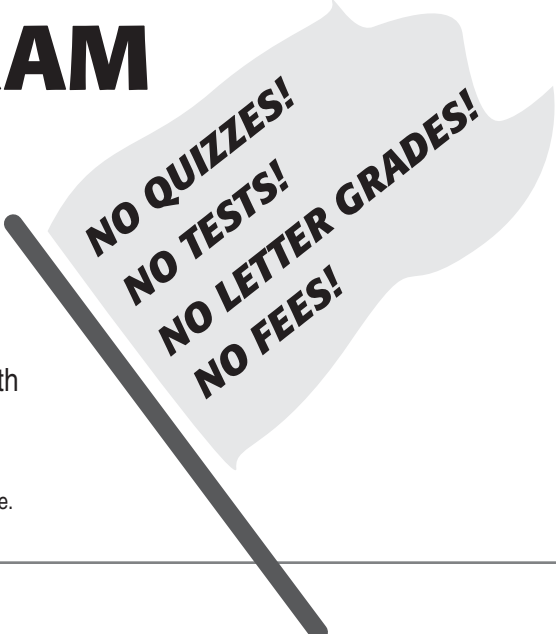

**NO QUIZZES!
NO TESTS!
NO LETTER GRADES!
NO FEES!**

Adults 55+

This program offers special interest classes to adults 55 and older. Our classes take place at various older adult facilities as well as Gavilan campuses to ensure positive enrollment and convenience for the students. Classes include:

- Arts and Crafts
- Body Dynamics and the Aging Process
- Coping with Loss
- Creative Writing Workshop
- Discover Your Family History
- Exploring the Web
- Film Classics
- Finding Book Treasures
- Internet Literacy I & II
- Journal Writing
- Legal Resources for Older Adults
- Microsoft Word
- Music Encounters
- Music, Movement & Wellness
- Tai Chi for Arthritis and Other Illnesses
- The Art of Storytelling
- The Joy of Listening to Music
- The Theater Experience
- Windows Fundamentals
- Writing Your Autobiography

Staff Wellness Program

This program is geared toward meeting the needs of working adults and others interested in maintaining a healthy lifestyle. All classes are free of charge and are open to all staff members as well as the community.

- Tai Chi for Health
- Mindful Stress Reduction

Parenting Program

- Parent Advocacy

Basic Skills Program

This program assists adult learners with their educational needs in areas of learning English, preparing for citizenship, and improving their basic skills in reading, writing and Math.

- ESL Citizenship
- GED Preparation
- Introduction to Online Gavilan
- Personal and Career Development
- Vocational ESL (Workplace Communications)
- CAHSEE Preparation (High School Exit Exam)
- ESL Life Skills
- Writers' Workshop

FALL NONCREDIT CLASSES

CRN Type Room Instructor Hrs. Units Days Begin-End

ALLIED HEALTH

AH 740 Tai Chi for Arthritis and Other Related Illnesses

Transferable: No

This course is designed for the maintenance of the physical and mental well-being of an older adult with arthritis and other related illnesses. Instruction will focus on the postures and movements of Tai Chi, a Chinese exercise regimen that has a slow paced movement that improves balance, coordination, breathing and builds strength and stamina. Activities are included that promote self-care and health awareness.

10424	Lab	WM1	Yinger K	2.00	TR	1000A-1100A
Above class meets at Wheeler Manor 651 W. 6th Street, Gilroy.						
10419	Lab	HHH1	Faulds H	1.00	S	1045A-1145A
Above class meets at Hazel Hawkins Hospital 911 Sunset Dr., Hollister.						
10421	Lab	JDA1	Frey E	1.00	R	1115A-1215P
Above class meets at Jovenes de Antano 300 West St., Hollister.						
10423	Lab	VPRI1	Yinger K	1.00	R	0100P-0200P
Above class meets at Valley Pines Retirement Inn 545 E. Main Ave., Morgan Hill.						

AH 741 Body Dynamics and Aging

Transferable: No

This course is designed for the 55+ adult student to provide awareness and knowledge of physical fitness, stress management and nutrition to personal health. Discussions will focus on nutrition, sleep disorders, depression, leisure/social activities and chronic conditions that effect the body as aging occurs.

10993	Lec	CRC1	Lee C	1.80	W	1030A-1200P
Above class meets at Centennial Recreation Center 171 W. Edmundson Ave., Morgan Hill.						

ART

ART 760 Arts and Crafts I for Older Adults

Transferable: No

A general survey of arts and crafts with an emphasis on exercises and experiments with methods and materials, including: painting, drawing, color theory, composition and rendering, batik or tie-dye, quilting or needlepoint, crocheting or knitting and block printing.

10253	Lab	HVME1	Gupta R	3.00	F	0930A-1230P
Above class meets at Hacienda Valley Mobile Estates 275 Burnett Ave., Morgan Hill. A \$25 materials fee will be charged.						
10251	Lab	WM1	Barrett S	3.00	M	0100P-0400P
Above class meets at Wheeler Manor 651 W. 6th Street, Gilroy. A \$25 materials fee will be charged.						

CRN Type Room Instructor Hrs. Units Days Begin-End

COMPUTER SCIENCE & INFORMATION SYSTEMS

CSIS 728 Windows for the Older Adult

Transferable: No

This course is designed as an introductory course for the older adults to learn Windows operations, file management and other Windows Fundamentals.

10427	Lab	CTC2	Hernandez A	2.80	T	0900A-1130A
Above class meets at Gavilan Computer Technology Center Room 2 7881 Murray Ave., Gilroy.						
10994	Lab	HOL3	Mendez F	2.00	MW	0430P-0530P
Above class meets at the Hollister Briggs site.						

CSIS 729 Word Processing-MS Word for the Older Adult

Transferable: No

A course designed for older adults (55+) to develop word processing skills to write and edit simple documents, format text, use bullets, create tables, insert clipart and use other features of the toolbar.

10430	Lec	CTC2	Hernandez A	2.80	R	0900A-1130A
Above class meets at Gavilan Computer Technology Center Room 2 7881 Murray Ave., Gilroy.						

ENGLISH

ENGL 749 Writers' Workshop

Transferable: No

Writers' Workshop is an open enrollment class that allows community members and students from all disciplines to participate in a regularly scheduled, instructor-facilitated writing response group. Activities include focused response to participants' writing, generative writing games and prompts and interaction with visiting writers and scholars.

10968	Lec	BU117	Smith K	1.80	T	0230P-0400P
10969	Lec	TBA	Smith K	1.80	W	0300P-0430P
Please call for location - 408-848-4800, x 5116						

ENGL 750 Creative Writing Workshop for Older Adults

Transferable: No

A class designed for older adults to develop their writing skills in a peer support group. They are guided in creative expression through prose and poetry. Older adults are encouraged to read their works in class and learn how to respond to writing, guided creative exercises and assignments, sentence and story structure.

10260	Lec	CRC1	Serrano K	1.80	M	0930A-1100A
Above class meets at Centennial Recreation Center 171 W. Edmundson Ave., Morgan Hill.						

ENGL 754 Discover Your Family History for Older Adults

Transferable: No

This class will assist older adults in the research and writing of their family histories. They will collect names of relatives and establish relationships through primary, secondary and/or circumstantial evidence and/or documentation. Various sources for researching including Internet use will be encouraged.

10261	Lab	CRC1	Serrano K	1.80	F	0930A-1100A
Above class meets at Centennial Recreation Center 171 W. Edmundson Ave., Morgan Hill.						

All noncredit classes are open entry/exit and free of charge.

CRN Type Room Instructor Hrs. Units Days Begin-End

ENGL 756 GED Preparation

Transferable: No

This course is designed to prepare the student to pass the five General Education Development (GED) tests in Writing, Social Studies, Science, Literature and Mathematics. English grammar and usage, reading comprehension, writing, vocabulary and computational skills are emphasized. The course is designed for students who are 18 years of age or older and elect to take the High School Equivalency Examination.

10281	Lab	CTC1	Miguel B	3.00	S	0900A-1200P
Above class meets at Gavilan Computer Technology Center Room 1 7881 Murray Ave., Gilroy.						
10279	Lab	HOL3	Miguel B	3.00	S	0100P-0400P
Above class meets at the Hollister Briggs site.						
11001	Lab	CTC1	Padilla M	2.00	M	0700P-0900P
Above class meets at Gavilan Computer Technology Center Room 1, 7881 Murray Ave., Gilroy.						

ENGLISH AS A SECOND LANGUAGE

ESL 702A ESL Citizenship

Transferable: No

This course is designed for second language learners that want to prepare for the United States Citizenship test given by the Department of Immigration and U. S. Naturalization Services. The focus will be on communicative English skills and knowledge of American History and Government required for passing the test to become a citizen of the United States. Readings are at the high-beginning/low-intermediate ESL level and will focus on the historical period beginning in the 1600's on through to 1980.

10262	Lec	HOLREC2	Segovia M	5.60	TR	0600P-0830P
Above class meets at Hollister Recreation Center Gabilan Room 375 5th St., Hollister.						
10263	Lec	STF1	Stuker D	3.60	MR	0600P-0730P
Above class meets at St. Frances 7950 Church St., Gilroy.						

ESL 704A ESL for the Workplace

Transferable: No

This is part A of a content-based integrated skills course for ESL students who want to prepare for immediate entry into the job force. Students expand their language skills within the realm of the work world and specific vocational career of interest while also developing the soft skills needed in the workplace. This course is a combination of lecture, lab, and self-paced instruction.

10432	Lab	CTC1	Rivoallon L	10.00	MTWRF	0900A-1100A
Above class meets at Gavilan Computer Technology Center Room 1 7881 Murray Ave., Gilroy.						
10434	Lab	JS1	TBA	4.00	MT	0600P-0800P
	Lab	MHG5	TBA	2.00	W	0600P-0800P
Above class meets on Monday & Tuesday at Jasmine Square Apts. 16530 Monterey Rd., Morgan Hill. Wednesday class will be at the Morgan Hill Site 17060 Monterey Rd.						
10436	Lab	CTC1	Padilla M	6.00	TWR	0700P-0900P
Above class meets at Gavilan Computer Technology Center Room 1 7881 Murray Ave., Gilroy.						

NEW ESL 777 ESL Lifeskills 1

Transferable: No

This is the first course in a series of survival English classes for students with very little oral or written English competency. It will give students basic vocabulary and familiarity in life skill areas such as the family, food, health, and occupations to manage in the real world. The course emphasizes oral communication and integrates listening, speaking, reading, and writing. ADVISORY: Placement into ESL Lifeskills by the CASAS placement test.

11004	Lec	MHG13	TBA	5.40	MWF	1000A-1130A
Above class meets at Morgan Hill Community site.						
11002	Lec	TBA	Segovia M	5.40	MWF	0600P-0730P
Please call for location - 408-848-4800, x 5116						
11005	Lec	TBA	TBA	5.40	MWF	0700P-0830P
Please call for location - 408-848-4800, x 5116						
11006	Lec	MV1	TBA	5.40	MTW	0700P-0830P
Above class meets at Monterra Village 950 Mantelli Drive, Gilroy.						
11003	Lec	TBA	Segovia M	5.40	MWF	0745P-0915P
Please call for location - 408-848-4800, x 5116						

CRN Type Room Instructor Hrs. Units Days Begin-End

NEW ESL 778 ESL Lifeskills 2

Transferable: No

This is the second course in a series of classes in survival English for students with very little oral or written English competency. It will give students basic vocabulary and familiarity in life skill areas such as the family, food, health, and occupations to manage in the real world. The course emphasizes oral communication and integrates listening, speaking, reading, and writing. ADVISORY: Placement into ESL Lifeskills by the CASAS placement test and successful completion of ESL 777.

11008	Lec	MHG13	TBA	4.00	TR	0930A-1130A
Above class meets at Morgan Hill Community site.						
11009	Lec	TBA	Vallejo M	5.40	TWR	0600P-0730P
Please call for location - 408-848-4800, x 5116						
11007	Lec	TBA	TBA	5.40	MWF	0700P-0830P
Please call for location - 408-848-4800, x 5116						
11010	Lec	TBA	Vallejo M	5.40	TWR	0745P-0915P
Please call for location - 408-848-4800, x 5116						

NEW ESL 779 ESL Lifeskills 3

Transferable: No

This is the third in a series of classes in survival English for students with little oral or written English competency. It will give students expanded basic vocabulary and familiarity in life skill areas such as the weather, transportation, employment, and American holidays and customs to manage in the real world. The course emphasizes oral communication and integrates listening, speaking, reading, and writing. ADVISORY: Placement into ESL Lifeskills by the CASAS placement test and successful completion of ESL 778.

11012	Lec	CTC3	Morley S	6.00	MWF	0900A-1100A
Above class meets at Gavilan Computer Technology Center Room 3, 7881 Murray Ave., Gilroy.						
11011	Lec	CTC2	TBA	5.40	MWF	0700P-0830P
Above class meets at Gavilan Computer Technology Center Room 2, 7881 Murray Ave., Gilroy.						

NEW ESL 780 ESL Lifeskills 4

Transferable: No

This is the fourth course in a series of survival English for students with little oral or written English competency. It will give students expanded basic vocabulary and familiarity in life skill areas such as weather, transportation, employment, and American holidays and customs to manage in the real world. The course emphasizes oral communication and integrates listening, reading, writing. ADVISORY: Placement into ESL Lifeskills by the CASAS placement test and successful completion of ESL 779.

10964	Lec	HOL6	TBA	5.40	MWF	0600P-0730P
Above class meets at the Hollister Briggs site.						
10996	Lec	RC1	TBA	5.60	MW	0630P-0900P
Above class meets at Royal Court 17935 Monterey St., Morgan Hill.						
10965	Lec	HOL6	TBA	5.40	MWF	0745P-0915P
Above class meets at the Hollister Briggs site.						

NEW ESL 781 ESL Lifeskills 5

Transferable: No

This is the fifth course in a series of survival English for students with beginning oral or written English competency. It will reinforce basic skills learned and continue to develop vocabulary and ease of communication in life skill areas such as the family, the larger community, health, employment, and leisure activities to manage in the real world. The course emphasizes oral communication and integrates listening, speaking, reading, and writing. ADVISORY: Placement into ESL Lifeskills by the CASAS placement test and successful completion of ESL 780.

10966	Lec	HOL4	TBA	5.40	MWF	0600P-0730P
Above class meets at the Hollister Briggs site.						
10998	Lec	RC1	TBA	5.60	TR	0630P-0900P
Above class meets at Royal Court 17935 Monterey St., Morgan Hill.						
10997	Lec	CTC3	TBA	5.40	MWF	0700P-0830P
Above class meets at Gavilan Computer Technology Center Room 3, 7881 Murray Ave., Gilroy.						
10967	Lec	HOL4	TBA	5.40	MWF	0745P-0915P
Above class meets at the Hollister Briggs site.						

CRN Type Room Instructor Hrs. Units Days Begin-End

HUMANITIES

HUM 767 Film Classics

Transferable: No

This class is designed to study the facts, fantasy, history and trivia of classic and modern films. The background and history of each film and its performance will be compared and contrasted.

10267 Lab HOLREC1 Sendejas L 2.80 F 1000A-1230P
Above class meets at Hollister Recreation Center Dunne Park Bldg. 375 5th St., Hollister.

11000 Lab PLY Richards G 3.00 W 0200P-0500P
Above class meets at Morgan Hill Playhouse 17000 Monterey Rd.

10273 Lab WM1 Sendejas L 3.00 S 0430P-0730P
Above class meets at Wheeler Manor 651 W. 6th Street, Gilroy.

LIBRARY

LIB 730 Internet Literacy for Older Adults

Transferable: No

A class for older adults to learn email techniques, how to find information on their interests, news sources, and the skill of browsing online, as well as how best to use the local public library online services, online shopping, search strategies, and interactive games.

10302 Lec HOL3 Mendez F 2.00 MW 0300P-0400P
Above class meets at the Hollister Briggs site.

LIB 732 Introduction to Online Gavilan

Transferable: No

Introduction to the online classes and student services at Gavilan College. This course will show students how to log into their online courses, find lectures, assignments and exams, take part in online class discussions, submit attachments, and view their grades. The course will also cover all the online student services available to the distant student, including counseling, library resources, records and grades, financial aid, tutoring and technical support.

10306 Online N/A Parker J
08/18/08 - 12/20/08 This online class will be delivered entirely over the Internet. Log in at www.gavilan.edu/disted to access the class any time during the semester.

LIB 733 Exploring the Web for Older Adults

Transferable: No

Designed to address the interests of older adults, students will learn about the web's rich offering in graphics, sharing digital pictures, and downloading audio files and audiobooks after paying your bills online. Students will learn online techniques to take advantage of all the latest tools, such as wikis, blogs, search techniques and great travel destinations. **ADVISORY:** LIB 730, Internet Literacy for Older Adults.

10264 Lec MHG5 Curtis G 2.00 R 0930A-1130A
Above class meets at Morgan Hill Community site.

10266 Lec HOL3 Mendez F 3.60 MW 0130P-0300P
Above class meets at the Hollister Briggs site.

CRN Type Room Instructor Hrs. Units Days Begin-End

LIB 734 Legal Resources for Older Adults

Transferable: No

Older Americans face a gamut of legal issues in planning their future and must be aware of their rights in order to stay in charge of their lives. Finding the way through the maze of legal resources is a learned process. This course touches on basic legal issues including elder law, consumer and small claims, wills and estate planning, power of attorney and health care directives. **ADVISORY:** LIB 730, Internet Literacy for Older Adults.

10962 Lec MHG12 Hayes C 3.00 W 0230P-0530P
10/01/08 - 11/05/08 Above class meets at Morgan Hill Community site.

10963 Lec BU119 Hayes C 3.00 W 0600P-0900P
10/01/08 - 11/05/08 Above class meets at Morgan Hill Community site.

MUSIC

MUS 763 Music Encounters

Transferable: No

A class for older adults that provides musical activities to stimulate and sustain their auditory function, discernment of sounds and manual dexterity. Students will enjoy music, new and old, by listening, singing, playing and creating music in a group setting.

10314 Lec VPRI1 Yinger K 1.00 T 0100P-0200P
Above class meets at Valley Pines Retirement Inn 545 E. Main Ave., Morgan Hill.

11013 Lec GHS Robb P 3.30 T 0600P-0905P
Above class meets at Gilroy High School, 750 West Tenth St, Gilroy.

11014 L/L PB5 Quartuccio A 3.30 W 0600P-0905P

PHYSICAL EDUCATION

PE 701 Tai Chi for Wellness

Transferable: No

This course will introduce the student to the thirty seven posture forms and movements of Tai Chi, an ancient Chinese practice that focuses on slow paced coordinated movements that improve balance, coordination, mobility and breathing. The students will also learn how to use this non-contact exercise program to reduce stress in their daily lives.

10425 Lab APE101 Yinger K 1.00 T 0530P-0630P

PE 716 Music/Movement and Health

Transferable: No

This course is designed to assist older adults in improving overall health through movement, music and relaxation techniques. Rhythmical movement will be adjusted to suit individual students mobility needs.

10315 Lab JDA1 Host M 2.00 T 1000A-1200P
Above class meets at Jovenes de Antano 300 West St., Hollister.

10318 Lab CRC1 Mendonca B 2.00 TF 1000A-1100A
Above class meets at Centennial Recreation Center 171 W. Edmundson Ave., Morgan Hill.

10414 Lab GSC1 Mendonca B 1.00 W 1000A-1100A
Lab GSC1 Mendonca B 1.00 F 0130P-0230P
Above class meets at Gilroy Senior Center 7371 Hanna St., Gilroy.

10974 Lab VPRI1 Lee C 1.80 F 1030A-1200P
Above class meets at Valley Pines Retirement Inn 545 E. Main Ave., Morgan Hill.

10412 Lab CRC1 Mendonca B 2.00 TF 1100A-1200P
Above class meets at Centennial Recreation Center 171 W. Edmundson Ave., Morgan Hill.

All noncredit classes are open entry/exit and free of charge.

Fall classes begin September 3, 2008
REGISTER EARLY!



ROP Courses

Regional Occupational Program (ROP) training is offered to residents of Santa Clara and San Benito Counties by the Santa Clara County Office of Education. Some classes are offered at Gavilan College. In some of the classes, students may earn high school or college credit, and upon completion they may be eligible for advanced placement at Gavilan College. ROP provides students with training to secure jobs, upgrade skills, or prepare for advanced career education. Students must be 16 years of age or older to participate. Classes are free for both high school students and adults. Gavilan College fees are charged for Gavilan College credit. ROP classes may have additional fees for textbooks and supplies. For information on ROP courses taught at Gavilan College, call 408-848-4816.

Students enrolled in ROP classes do not qualify for Financial Aid.

ROP Accounting

General Office Accounting

Advisory: Eligible for Mathematics 205

This course is designed to prepare students for entry-level office accounting positions. Emphasis is on practical accounting applications. This course has the option of a letter grade or pass/no pass. For college credit, enroll in Gavilan's ACCT103.

Room	Instructor	Day	Time
BU118	College A	F	0900A-1205P

Payroll Accounting

Advisory: Eligible for Mathematics 205, completion of Accounting 101.

An introduction to the calculating, journalizing, paying and reporting of employee earnings, employee withholding and employer payroll tax expenses. The course emphasizes procedures which conform to federal and state legal requirements. This course has the option of a letter grade or pass/no pass. For college credit, enroll in Gavilan's ACCT105.

Room	Instructor	Day	Time
MHG4	Barta M	R	0600P-0905P
09/25/08 - 12/11/08 Above class meets at Morgan Hill Community site.			

Introduction to Income Tax

Advisory: Eligible for English 250, English 260 and Mathematics 205.

A study of theory, philosophy, and principles of income tax law and procedures for computing the tax liability. It includes practice in solving typical individual tax problems. This course has the option of a letter grade or pass/no pass. For college credit, enroll in Gavilan's ACCT111.

Room	Instructor	Day	Time
10354 Lec	MHG4 Barta M	3.30 3.0 T	0600P-0905P
Above class meets at Morgan Hill Community site.			

ACCT 120 Computerized Accounting - QuickBooks

Advisory: CSIS 1 or CSIS 2 or the equivalent computer experience. ACCT 20 or ACCT 101 or ACCT 103 or ACCT 105 or the equivalent accounting experience.

An introduction to computer-assisted accounting. Hands-on use of a microcomputer menu-driven accounting package to do general ledger, sales journal, cash receipts journal, cash payments journal, purchases journal, payroll, receivables, payables and related financial reports. This course has the option of a letter grade or pass/no pass. Repeatable whenever a new software package is adopted. This course is also listed as CSIS 120. For college credit, enroll in Gavilan's ACCT120.

Room	Instructor	Day	Time
HOL3	College A	F	0530P-0835P
Above class meets at the Hollister Briggs site.			

ROP Computer Applications

Computer Office Applications

Advisory: Basic keyboarding skills

This introductory course for word processing with Windows offers students hands-on skills to create business correspondence, reports, presentations, spreadsheets, and desktop publishing. Software includes: Word, Excel, and Powerpoint.

Room	Instructor	Day	Time
HOL 3	Hernandez A	TR	12:30 P - 3:50 P
Above class meets at the Hollister Briggs site			

ROP Business Office Technology

Medical Terminology for the Office

Advisory: Eligible for English 250 and English 260.

This course introduces fundamentals of medical word building used in the health profession (prefixes, word roots, suffixes and abbreviations) as well as review of body systems, with emphasis on analysis, definition, spelling and pronunciation. This course had the option of a letter grade or pass/no pass. For college credit, enroll in Gavilan's BOT180.

Room	Instructor	Day	Time
MHG4	Knapp D	R	0300P-0555P
Class meets at Morgan Hill Community site.			

Medical Billing - MediSoft

Advisory: Eligible for English 250. Some computer experience.

This course in computerized billing procedures for a medical office uses MediSoft software. Students will learn the patient billing features of this software and complete a capstone simulation giving them hands-on realistic medical front office practice. This course has the option of a letter grade or pass/no pass. May be repeated three times for credit. For college credit, enroll in Gavilan's BOT181.

Room	Instructor	Day	Time
BU110	Knapp D	W	0600P-0905P

Medical Coding

Advisory: BOT 180.

This course will introduce the student to the theory and procedure of coding for medical diagnoses, an increasingly essential and specialized healthcare communication system. The course is not a certification course. CPT coding is covered, with an overview of ICD-9 coding. This course has the option of a letter grade or pass/no pass. May be repeated three times for credit. ADVISORY: BOT 180. For college credit, enroll in Gavilan's BOT183.

Room	Instructor	Day	Time
LS106	Hardcastle C	F	0945A-1240P



Short-term Training Program
ROP Dental Assisting

Includes Radiology (X-Ray) Certification

Location: ROP-South, 700 W. 6th St., Ste. L, Gilroy

Registration: Tuesday, August 5, 2008

Doors open at 7:45 am and registration begins promptly at 8:00 am (25 spaces available)

Class dates and times:

September 2, 2008 - January 23, 2009

Mon-Fri, 9:30 am - 3:00 pm

Cost: \$220 includes book and lab fee. Students must purchase lab coats.

This course includes instruction in chairside assisting as well as x-ray certification.

Call the ROP Main Office at
(408) 842-0361
 for more information.

ROP Administrative Medical Assisting

Basic Clinical Medical Assisting

Prerequisite: Eligible for English 250, English 260 and Mathematics 205.

Course provides a basic introduction to clinical medical assisting. Emphasizes principles, understanding of skills necessary to perform basic clinical medical assisting procedures safely and effectively. For college credit, enroll in Gavilan's AH170.

Room	Instructor	Day	Time
HOB114	Kearbey A	TWR	1250P-0430P

ROP Industrial Technology

Industrial Safety

Advisory: Eligible for English 250 and English 260.

This course is an introduction to the construction industry. It will cover the basic skill sets required to earn an entry-level position in various trades in construction. Students will learn basic math, vocabulary, blue print reading and safety skills along with the soft skills required to gain employment. This course has the option of a letter grade or pass/no pass. For college credit, enroll in Gavilan's IT115.

Room	Instructor	Day	Time
SS205	Wright D	W	0600P-0905P

ROP Nursing Assistant

Fundamentals of Nursing--Convalescent

A course to provide a basic introduction to patient care in the convalescent setting. Emphasizes principles, understanding and skills necessary to perform basic nursing procedures safely and effectively. Includes introduction to health care, planning, safety, infection control, personal care, basic procedures, rehabilitation, nutrition and clients' rights and needs. At the completion of this course students will qualify for state certification as a nursing assistant. **PREREQUISITE:** Eligible for English 250 and English 260. Clearance from the Department of Health Services (Form HS283), fingerprint card, and health clearance required prior to clinical placement. Health and fingerprint clearance required prior to clinical placement. Uniform, shoes, watch, and stethoscope required. Clinical in Morgan Hill or Hollister, as assigned. For college credit, enroll in Gavilan's AH180.

Room	Instructor	Day	Time
HOB114	Machado M	MT	0910A-1200P
HOB114	Machado M	W	0630A-0130P
Room	Instructor	Day	Time
HOB114	Machado M	MT	0910A-1200P
HOB114	Machado M	R	0630A-0130P

Home Health Care

Transferable: CSU

Course is designed to prepare students to provide basic health care in the home. Includes interpretation of medical/social needs, personal care services, cleaning tasks, nutrition, and the scope of limitations of a home health aide. All students who achieve a grade of "C" or better will be eligible for a Home Health Aide certificate from the State of California. **PREREQUISITE:** California CNA certification or concurrent enrollment in AH 180 or equivalent. Equivalency determined by written and performance exams. Also, eligible for English 250 and English 260. Clearance from the Department of Health Services (Form HS283), fingerprint card, and health clearance required prior to clinical placement. For college credit, enroll in Gavilan's AH182.

Room	Instructor	Day	Time
HOB114	Machado M	S	0630A-0130P

10/11/08 - 11/15/08 Short-term class meets on specified dates.

Gavilan College's own
 educational TV station

Gav TV Channel

18

**Additional
ROP
sites in the
Gavilan College
District**

All day classes offered at high school locations are part of the regular high school schedule. Adults are admitted on a space-available basis by contacting the high schools.

ROP Instructional Services Gilroy
408-842-0361
Dental Assisting

Anzar High School
408-623-7660
Audio Video Publishing
Photography

Gilroy High School
408-847-2424
Auto Technology
C.A.D. Drafting
Commercial Photography
Computer Bus. Application
Criminal Justice
Digital Design and Animation
Horticulture-Ornamental
Sports Medicine I & II
Veterinary Medicine
Visual Communications

Live Oak High School
408-201-6129 or 408-201-6111
Agriculture Sales/Services
Cabinet Making
Careers with Children
CISCO Networking
Fashion Design
Graphic Technology
Photography, Commercial
Technical Writing
Veterinary Science
Web Design

San Andreas High School
Call 831-637-9269
Computer Bus. Appl.

San Benito High School
831-637-5831, ext. 185

Ag. Fabrication-Construction
Audio Video Publishing
Auto Mechanics
C.A.D. Drafting
Cabinet Making
Child Care
Commercial Art
Computer Accounting
Computer Programming
Computer Repair
Computerized Bus. Appl.
Food Service/Restaurant Careers
Marketing
Metals Fabrication
Sports Medicine
Technical Writing

Sobrato High School
408-201-6200
Ag Sales
Biotechnology
Commercial Photography
Sports Medicine
Veterinary Science
Web Design
Welding

FINAL EXAM SCHEDULE

Monday - Sunday, December 15-21, 2008

This schedule is designed to provide dates and two-hour blocks of time for Final Exams in credit courses. Final exams will begin Monday, Dec. 15, 2008. Classes meeting prior to 8 a.m. will take their exams during the same week, for a two-hour period beginning at the class starting hour.

All finals are to be given at the scheduled time, and in the room in which the class has regularly met during the semester. Exceptions can be granted only by the department chair and the area dean.

If a class appears not to have a time scheduled according to the chart below, please see the instructor, department chair or area dean. Instructors' office hours will be changed to accommodate the final exam schedule. Please check at the instructor's office for the revised schedule.

If your class meets on these days:

Daily, M, MTuW, MTuWF, MW, MWTh, MWThF, MWF, MTh, MThF, MF, W, WTh, WThF, WF

Starts at any time between:	Your final exam will be:	
08:00 - 09:40	Mon.	Dec. 15 08:00 - 10:00
09:45 - 11:00	Wed.	Dec. 17 08:00 - 10:00
11:05 - 12:20	Mon.	Dec. 15 10:30 - 12:30
12:25 - 01:40	Wed.	Dec. 17 10:30 - 12:30
01:45 - 03:00	Mon.	Dec. 15 01:00 - 03:00
03:05 - 04:30	Wed.	Dec. 17 01:00 - 03:00

If your class meets on these days:

MTu, MTuWTh, MTuTh MTuThF, MTuF, Tu, TuW, TWTh, TuWThF, TuWF, TuTh, TuThF, TuF, Th, ThF

Starts at any time between:	Your final exam will be:	
8:00 - 9:10	Thur.	Dec. 18 08:00 - 10:00
9:15 - 10:25	Tues.	Dec. 16 08:00 - 10:00
10:30 - 11:40	Thur.	Dec. 18 10:30 - 12:30
11:45 - 12:55	Tues.	Dec. 16 10:30 - 12:30
1:00 - 2:10	Thur.	Dec. 18 01:00 - 03:00
2:15 - 3:25	Tues.	Dec. 16 01:00 - 03:00
3:30 - 4:55	Tues.	Dec. 16 03:30 - 05:30

Fri or Fri/Sat classes: If your class meets at ANY start time between 8-10:55 am, the final exam will be: Friday, May 23 from 8:00-10:00 am. If your class meets at ANY start time between 11:00 am - 1:55 pm, the final exam will be: Friday, May 23 from 10:30 am - 12:30 pm

Make-ups and Conflicts:

Mon.	Dec. 15	03:30 - 05:30
Thur.	Dec. 18	03:30 - 05:30
Wed.	Dec. 17	03:30 - 05:30

Exams for classes held on Saturdays, Sundays & Evenings

All classes held on:

Monday evenings	Mon.	Dec. 15
Tuesday evenings	Tues.	Dec. 16
Wednesday evenings	Wed.	Dec. 17
Thursday evenings	Thurs.	Dec. 18
Friday evenings	Fri.	Dec. 19
Monday/Wednesday evenings	Mon.	Dec. 15
Tuesday/Thursday evenings	Tues.	Dec. 16
Saturday	Sat.	Dec. 20
Sunday	Sun.	Dec. 21

Join
the
Concert
Choir!
MUS 13

CRN 10702
Tuesdays 6:00 - 9:05 pm
with Phil Robb
Meets at Gilroy High School



Student Services

CalWORKs CalWORKs serves students who receive public assistance to become self-sufficient through the provision of education, employment and supportive services. The occupational programs for CalWORKs students are linked to the demands of the local labor market and can assist students with a career track that will lead to a family-supporting income. The support services that CalWORKs provides include academic, personal and career counseling, textbooks, employment assistance and job placement and serves as a liaison with county departments of social services.

The CalWORKs staff is friendly and supportive and will work with students to help them reach their goals. The office is located in L101 A, next to the library and is open Monday through Friday, 8 a.m. to 5 p.m. Interested students may call 408-848-4740.

CARE The Cooperative Agencies Resources for Education (CARE) is a special program designed to assist single parents who attend or would like to attend Gavilan College. CARE is a joint effort among the Department of Social Services, EOPS and Gavilan College. To be eligible for CARE, a student must be at least 18 years of age, head of household single parent/grandparent receiving cash assistance from the Department of Social Services, have at least one child under 14 years of age and be eligible for EOPS.

Services provided include:

Transfer and vocational education and counseling • Priority registration • Academic tutoring • Financial assistance with transportation, books, supplies, grants • Other support services

For additional information, call 408-848-4790 or visit the EOPS office located in L101 A & B.

Career/Transfer Resource Center See ad on page 125.

Child Development Center/Preschool The Child Development Center provides care for preschool children in two state-funded programs for families whose monthly income meets eligibility criteria. In addition, a fee based preschool program is available to all parents. These programs serve children with disabilities and special needs as well as children who are limited or non-English speaking. The Center is the only facility in Gilroy that is accredited by the National Association for the Education of Young Children (NAEYC)

The Center is located above parking lot C and is open Monday - Friday. For more information call 408-848-4815.

Disability Resource Center (DRC) DRC provides a variety of services and classes in an effort to equalize educational opportunities for students with disabilities as they move toward their educational or vocational goals.

Services include: Note taking • Academic, Career and Personal Counseling • Referral Services • Learning Skills Assessment • Vocational Preparation • Learning Skills Strategies Assistance • Registration Assistance • Mobility Assistance • Vocational Aptitude Testing • Multi-media Educational Aids • Sign Language Interpreting • Job Training and Placement • Individualized Accommodations • Alternate Media Services

DRC CLASSES OFFERED:

Guidance Courses:

Guid 530	Job Readiness
Guid 557	Learning Skills Assessment
Guid 558	Learning Skills Laboratory
Guid 560	Individualized Basic Skills Development
Guid 561	Writing Skills
Guid 562	Directed Study Lab in Arithmetic
Guid 563A/B	Directed Study Lab in Algebra
Guid 564	Directed Study Lab in Pre-Algebra

Adapted Physical Education:

PE 34/534	Adapted Aquatic Exercise
PE 35/535	Adapted Swimming for Total Fitness
PE 36/536	Adapted Physical Education
PE 38/538	Adapted Cardiovascular Conditioning and Training

Computer Science Classes:

CSIS 570	Computer Access Evaluation
CSIS 571	Computer Assisted Instruction
CSIS 572	Adaptive Computer Basics

Vocational Preparation: These programs are offered for students with developmental disabilities at three sites: Gavilan College, HOPE in Gilroy and HOPE in Hollister.

Students requiring accommodations or arrangements because of hearing, visual, or other disabilities should contact their instructor, counselor, or the Adapted Services Specialist at the Disability Resource Center located in LI 117. For more information call 408-848-4865.



LIBRARY DATABASES <http://www.gavilan.edu/library>

Discover the rich resources available with your Gavilan Library card. Whether for your term-paper or your interests, current and reliable materials specifically designed for Gavilan courses are available from the library databases. About a third of all the library materials are from "proprietary" databases. That means we pay for these materials on your behalf; they are not available to the public at large. About a million online magazine and newspaper articles cover a wide range of topics, e.g.

- elections and politics
- controversial issues
- literature
- history
- health
- psychology
- sciences

GET YOUR LIBRARY CARD NOW!

Your library card gives you access to library resources:

- access to computers in the library
- books, eBooks, reserve materials and more
- access to all electronic databases, on campus or from home

Students can get their library cards in person or online. Library cards are available to registered Gavilan students, staff and faculty, as well as community residents with a valid photo identification. Visit <http://www.gavilan.edu/library> for more information.

Extended Opportunity Programs & Services (EOPS)

Extended Opportunity Programs and Services provides access and support services for low-income students facing social, economic and educational challenges.

The EOPS Program services include:

Counseling: Academic, career and vocational counseling • Personal problem-solving and crisis intervention • Vocational interest testing • Four-year college transfer assistance • Field trips to major four-year colleges • Community agency and emergency referrals

Financial Assistance: grants • book vouchers

Specialized Workshops for facilitating student success

Other Services: student computer center • one-on-one tutoring • book lending service • priority registration

The EOPS office is located in L101 A & B in the library and is open Monday through Friday, 8 a.m. to 5 p.m. Students who are interested may call 408-848-4740.

First-Year Experience Gavilan College offers a program for “first-time,” new students who want to strengthen their reading, writing and study skills while at the same time becoming familiar with the campus and its resources. Teachers and counselors work together to help students develop connections between the courses and their college experience. The goal is to help students build a strong foundation and place them on the road for college success. See class listings on page 83.

Health Services Gavilan College provides a full-time college nurse who provides health services, health information, health education events, health counseling and referrals.

Students receive confidential, personal health counseling for a variety of health concerns. Health Services provides first aid treatment, blood pressure screening, tuberculin skin testing for students, HIV testing referrals, condoms and over-the-counter medications such as aspirin. Pamphlets and classes are available on nutrition, hepatitis, stress management, AIDS, suicide and other health topics. Sexual assault provided in small group settings. Referrals for health conditions including alcohol and drug intervention are available. Health Services provides first aid kits throughout the campus and at the satellite sites, responds as a member of a team to campus emergencies on the main campus and provides information regarding outside health insurance for the college student.

Health Services is a comprehensive “one stop” center for a variety of health services located in the Admissions Building (SC 118.) Services are free and available Monday - Friday on the main campus in Gilroy. For additional information call 408-848-4791.

Outreach and Recruitment Services The services of the Outreach and Recruitment Office are designed to familiarize the community with the variety of programs and services available at Gavilan College. We will schedule tours of the campus or visits to a specific department, or provide information on academic, vocational and transfer opportunities. Outreach and Recruitment will also arrange for representatives from Gavilan to make presentations at your school or event.

For further information or to schedule a workshop, presentation or tour, please contact Outreach Services at outreach@gavilan.edu or call (408) 846-4993. Office location: BU 125.

Puente The mission of the Puente Program is to increase the number of educationally underserved students who plan to transfer to four-year colleges and universities, earn degrees and return to the community as leaders and mentors to future generations. Puente is open to all students.

English Instruction: Puente students take two consecutive writing classes, English 250 (Practical Writing) and English 1A (Composition). These classes provide a supportive and stimulating environment for Puente students to build confidence in their writing skills through an exploration of the Mexican American/Latino experience.

Counseling: Puente students work closely with their Puente counselor until they graduate, exploring career options, developing an academic educational plan and identifying lifetime goals. Students visit University of California and California State University campuses and attend an annual Puente student transfer conference.



Health Insurance for students

Affordable year-round insurance is now available for community college students enrolled in a minimum of 6 units!

\$100 deductible per year (Visit Gavilan College's Health Nurse for a referral and the deductible is lowered to only \$50 per year!)

Visit the doctor of your choice.

Benefits include: hospitalization, emergency room visits, surgery, doctor's visits, treatment for mental and nervous conditions, prescription drug coverage, toll-free Nurse Advice Line.

For more information call 1-800-853-5899
or visit www.wellsfargo.com/studentinsurance

Sponsored by the Community College League of California

All Puente students are also required to enroll in Guidance 6 (Life Skills for Higher Education) and Guidance 1 (Self-Assessment and Career Development).

Mentors: Each Puente student is matched with a mentor from the business or professional community. Mentors share with students their personal, academic and career experiences, and provide a window into “real-life” work environments. The network of trained Puente mentors provides many resources for the Puente students, their families, their colleges and their communities. If you are interested in more information please visit SC 105 or call 408-848-4807.

Student-to-Student Mediation Mediation services will provide students with an opportunity to problem-solve together in a safe environment. Trained student mediators will work with two or more students who are in conflict to reach mutually agreeable solutions. Mediation services are free and confidential. Students wishing to become mediators can register for Introduction to Conflict Resolution (Psychology 6).

To obtain mediation services for a dispute on campus, contact the Counseling Department at 408-848-4723.

Transfer Services See Career/Transfer Resource Center ad on page 125.

TRIO Student Support Services The TRIO Student Support Services Program is funded by the Department of Education to specifically identify and support students who fit one of the following criteria: “first generation” college students, low income or students with verified disabilities. TRIO provides additional services such as academic counseling, tutoring, technology access, learning communities, cultural and social activities, and university visits.

TRIO is committed to increasing students' success in math and English courses and creating a “sense of place” for those who sometimes feel isolated and disconnected during their college experience. If you are interested in more information please visit the TRIO Program in the Student Center (SC 160 & 161) or call 408-846-4981.

Veteran Affairs Benefits Gavilan College recognizes credit and grants credit to veterans and reservists for service and training completed in the Armed Forces. Gavilan College reports as credit for prior training only those prior units that are required for the student's current objective at Gavilan College. Students having questions pertaining to eligibility for benefits, application procedures and other veteran matters should contact the Veteran Affairs official in the Financial Aid Office (SC124) or call 408-848-4727.

GENERAL EDUCATION RECIPROcity AGREEMENT The Gavilan Community College District has entered into a mutual agreement with seven other community Colleges to accept the general education of these colleges. The participating colleges are Chabot College (Hayward), De Anza College (Cupertino), Evergreen Valley College (San Jose), Foothill College (Los Altos Hills), Gavilan College (Gilroy), Mission College (San Jose), Ohlone College (Fremont), San Jose City College (San Jose) and West Valley College (Saratoga).

Students who obtain a Certification of Completion of Associate Degree General Education or complete an associate degree at any of the participating colleges will have both their general education course work and graduation proficiencies accepted as completed at any one of the participating campuses.

GAVILAN COLLEGE ASSOCIATE'S DEGREE GENERAL EDUCATION REQUIREMENTS (2007-2008)		
<p>1. File a Petition to Graduate with the Admissions and Records Office by April 1 for Spring or Summer graduation, and by October 1 to graduate at the end of the Fall Semester. One petition must be filed for each Associate degree, Certificate of Completion or Award of Achievement the student expects to receive.</p> <p>2. Maintain a cumulative grade point average of 2.0 ("C") or higher for all work attempted and a grade of "C" or higher in each major or certificate courses.</p> <p>3. Complete a minimum of 18 units of coursework in a major. Specific major course requirements are listed in the college catalog.</p> <p>4. Complete a minimum of 60 semester units. Within the (60) unit requirement, the (9) units in Area A, and B-4 must be completed with a grade of "C" or better in each course. Complete the last 12 units, or a total of 48 units, at Gavilan College.</p> <p>NOTE: Effective fall of 2009, the new Gavilan College graduation requirements will include ENGL 1A (Area A2 of the A.A./A.S. Gavilan College General Education Pattern) and Math 233 (Area B4).</p>		
AREA A	AREA C	AREA E
<p>COMMUNICATION IN THE ENGLISH LANGUAGE One course from each of these three areas: 6 Semester Units</p> <p>A - 1 ORAL COMMUNICATION CMUN 1A, 5, 8, or 10</p> <p>A - 2 WRITTEN COMMUNICATION ENGL 1A, or ENGL 250</p> <p>A - 3 READING ENGL 260 or SSCI 270A or SSCI 270B with a grade of "C" or better, or demonstrate reading proficiency at the college level. (Competency may be verified by an approved test.)</p>	<p>ARTS, FOREIGN LANGUAGE LITERATURE AND PHILOSOPHY One course from each of these two areas: 5 Semester Units</p> <p>C - 1 FINE AND PERFORMING ARTS Any Art, Theatre Arts or Music course (other than Area 2); CMUN 2; HUM 10; Journalism (other than Journalism 10.)</p> <p>C - 2 CULTURAL HISTORY, FOREIGN LANGUAGE, PHILOSOPHY ART 11, ART/HIST 21; ENGL 1B, 1C, 2A-F, 2H, 2I, 2J, 4A, 4B, 5A, 5B, 9A, 9B, 9C; HIST 1, 2, 3, 4A, 4B, 5, 6, 7A, 7B, 10, 12, 14, 18, 19; HUM 3, 4, 5, 10; JOUR/SOC 10, PHIL 1, 2, 3A, 3B, 4, 6A, 6B, 7A, 7B, 8, 15; any foreign language.</p>	<p>LIFE-LONG UNDERSTANDING AND SELF-DEVELOPMENT 3 Semester Units</p> <p>1. One unit of Physical Education activity class or Intercollegiate Sport.</p> <p>2. Minimum of two units from: AH 3, 30, AH/BIO 11; CSIS 1, 2, 6, 8, 45, 51; GUID 1/PSYC 5, GUID 6, 200; HE 1, 2; PHIL 3B, 6B, 8, 15; POLS/PSYC 27; PSYC/CD 2, 3; PSYC 41; SOC 21</p>
AREA B	AREA D	AREA F
<p>PHYSICAL UNIVERSE AND ITS LIFE FORMS One course from each of these three areas: 9 Semester Units The Physical or Life Science course must include a laboratory (indicated in BOLD.)</p> <p>B - 1 PHYSICAL SCIENCE ASTR 1; CHEM 1A, 1B, 12A, 12B, 30A, 30B; GEOG 1; GEOL 1, 13; PHYS 1, 2A, 2B, 4A, 4B, 4C; PSCI 1, 2</p> <p>B - 2 LIFE SCIENCE ANTH 1; ECOL 1; BIO 1, 4, 5, 7, 8, 9, 10, 13, 15, 20</p> <p>B - 3 LABORATORY ACTIVITY Lab courses are bold in Areas B-1 and B-2 above.</p> <p>B - 4 MATHEMATICS Minimum of Math 205 or equivalent. (Competency may be verified by an approved test.)</p>	<p>SOCIAL, POLITICAL, AND ECONOMIC INSTITUTIONS One course from area one and two courses from area two: 9 Semester Units</p> <p>D - 1 U.S. HISTORY AND POLITICAL INSTITUTIONS (3 units) One course from HIST 1, 2, 5, 18, 19 or POLS 1</p> <p>D - 2 BEHAVIORAL, ECONOMIC and SOCIAL SCIENCE (6 units) Two courses from AJ 6, 10; ANTH 2, 3, 5, 8, 9, 10; General Business 1; CMUN 4; ECON 1, 2, 10; GEOG 2; HIST 1, 2, 3, 4A, 4B, 5, 6, 10, 12, 14, 18, 19; JOUR/SOC 10; POLS 1, 3, 4; POLS/PHIL 12; POLS/PSYC/AJ/6; PSYC 1A, 1B; PSYC/CD 2, 3, 7; SOC 1A, 1B, 3, 4; SSCI 1</p>	<p>CULTURAL DIVERSITY 6 Semester Units 2 courses from the following list; courses listed under more than one area may be used, double counted, to satisfy other general education requirements.</p> <p>AH3, AH/BIO 11; ANTH 3, 5, 9, 10; ART 10A, 11, 20, ART/HIST 21; CD/PSYC 7; CMUN 4; ENGL 2B, 2E, 2H, 2I; GEOG 2; HIST 3, 5, 6, 10, 12; PHIL 6A, 15; POLS 3, 4; SOC 3; SPAN 9A, 12A, 12B; THEA 1</p>

Instructional Support & Labs

Bookstore Visit the Gavilan Bookstore on the Gilroy main campus early. Used books may be available at reduced cost. See ad on page 55.

Computer Place The Computer Place is a student service that supports student learning and academic success. Services provided include Internet and email access, word processing, Spanish support software, scanning, free printing in black and white, minimal charge for color printing and transparencies. For more information, call 408-848-4729 or visit the lab in the Library (L168) Monday - Thursday, 8:00 am - 5 pm and Friday, 8:00 am to 12:00 pm. (summer hours: M-Th, 8:00 am - 4:00 pm)

English as a Second Language (ESL) Computer Lab

The ESL Program has its own dedicated computer lab with a variety of software programs for all levels and classes. Students, at their convenience, practice and enhance language learned in class. The ESL computer lab is located in the Business Building (BU119.) Call 408-848-4856 for more information.

Learning Communities In learning community courses, you work and study with others so you'll be more successful in the course. Also, by linking two or more courses together, you'll begin to see greater connections between the disciplines. Research shows that when you take a learning community course, you become a stronger student and do better in your other college courses.

Library The Gavilan College Library delivers an array of print and electronic resources to the college community. Augmenting the 65,000 title printed book collection are 19,000+ eBooks, and over 2,500 magazine titles, many available online in electronic databases. Recent additions include an extensive DVD, film and talking book collection. The Library staff prides itself on being a leader in information literacy projects and web-based instruction and has received several state grants supporting that effort. The Library faculty also teaches various courses on Internet use, and works in tandem with other faculty in planning and revising courses with an information literacy component.

The Library homepage at www.gavilan.edu/library/ provides an online catalog of our book collection, links to various class websites and key online resources. The Library is open from Monday-Thursday, from 8:00 am - 8:00 pm and Friday from 8:00 am - 3:00 pm. For more information call 848-4810 (Circulation) or 848-4806 (Reference.)

Math Lab The math lab provides a place for students to practice math skills and receive individualized help with math problems at every level, from Basic Mathematics to Calculus. Students can work with math instructors, the math lab assistant or other students. Computers in the lab provide tutorial software as well as math software for Geometry, Statistics and Calculus projects. The Math Lab is located in PH101. To download the daily schedule or for free math downloads, visit the website at <http://gavilan.edu/mathlab/>. For more information, call 408-848-4959.

MESA The MESA (Mathematics, Engineering, and Science Achievement) Undergraduate Program is a partnership between the University of California (UC) and California Community College Chancellor's Office. The program provides services to qualified students who are 1) majoring in math and science based fields (ie Biology, Chemistry, Engineering etc.), and 2) planning to transfer to 4-year universities in order to graduate with baccalaureate degrees and have financial need and are first generation college students. Open to all eligible students, MESA emphasizes participation by educationally underserved students. MESA provides a study center, Academic Excellence Workshops, tutoring, university trips, academic advising, workshops and more. For more information go to www.gavilan.edu/mesa or call 408-846-4968.



Transfer Checklist

Are you preparing to transfer to a four year university? If so, planning now will guarantee a smooth and easy transition from Gavilan to the institution of your choice. Follow the recommended PLAN FOR SUCCESS:

First Year at Gavilan:

FALL SEMESTER

- Meet with a counselor and inform him/her of your intent to transfer.
- Request a current copy of the general education pattern you wish to follow (IGETC or CSU)
- Refer to the Gavilan catalog for course descriptions.
- Begin to investigate possible major choices.
- Develop an educational plan with a counselor.
- Request that all high school and college transcripts be sent to Gavilan.

SPRING SEMESTER

- Meet with counselor to discuss academic progress and major choice.
- Update educational plan to include major preparation courses.
- Consider participating in student clubs, student government, etc.
- Identify at least 3 universities and check the required major preparation.
- Determine eligibility for an Associates Degree from Gavilan.

Second Year at Gavilan:

FALL SEMESTER

- Meet with counselor to discuss course selections and to review educational plan.
- Verify completion of units, general education, and major preparation.
- Update educational plan, if necessary.
- Apply for scholarships and financial aid.
- Apply for college admissions.

SPRING SEMESTER

- Submit a Gavilan graduation petition.
- Read all of your correspondence from universities.
- Follow university instructions and meet deadlines.
- Keep copies of all correspondence
- Send official transcript showing work completed and courses in progress for spring.
- At the end of the semester, request two copies of your final transcripts (spring grades included) and a G.E. certification. One copy is sent to the university that you plan to attend and the second copy is for you to keep for your personal record.

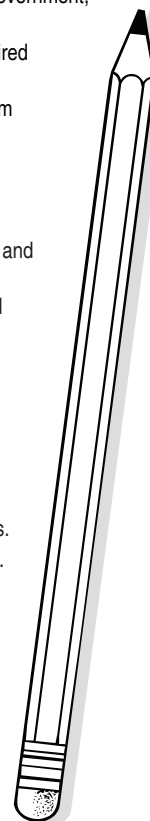

Reading Lab The Reading Lab supports the needs of students in reading classes with a special emphasis upon the English as a Second Language (ESL) classes. For more information, call 408-846-4980 or visit the lab in the Library (LI200a.) The lab is open Monday through Thursday 8 am - 3 pm; Friday 8 am - 12 pm.

Service Learning at Gavilan

In service learning classes, students work under supervision at a partner agency in the community for 10-40 hours a semester, and write reflective papers to connect the agency experience to their classroom learning. A number of Gavilan College departments have offered Service Learning for years, and a new AA degree in Social Science with a concentration on Community Studies will make Service Learning a key part of a major program at Gavilan. Service learning promotes civic engagement and academic excellence, and students participating benefit themselves and the community at the same time.

Why take a Service Learning class?

- Students report positive, meaningful and real experiences
- Students have better retention and better grades in SL classes than in non SL sections of the same classes
- Students often report success in investigating or discovering career options
- Some students later get jobs or at least skills and recommendations from the agencies where they volunteer; most gain knowledge of themselves and their communities
- SL involves cooperative rather than competitive experiences, promoting invaluable workplace skills associated with teamwork, community involvement, citizenship
- Students address complex problems in complex settings rather than simplified problems in isolation
- Students engage in problem-solving, gaining knowledge of the specific context of their service-learning activity and community challenges, which brings to life "book learning." As a result, service-learning offers powerful opportunities to acquire the habits of critical thinking; i.e. the ability to identify the most important questions or issues within a real-world situation
- Students report deeper learning because the results are immediate and uncontrived.
- Because of the immediacy of experience, service-learning is more likely to be personally meaningful to participants and to generate emotional consequences, to challenge values as well as ideas, and hence to support social, emotional and cognitive learning and development
- Service Learning is common at transfer colleges, particularly the CSUs
- Many students report becoming Lifelong Service Learners

Transfer Institute The Transfer Institute (TI) is a selective program designed for students who want to transfer to a public or private university in two years. Recent high school graduates who are academically prepared for college level work and students with placement in college level English and math are eligible.

The Transfer Institute will guide the student through the transfer process in the most efficient and effective means possible.

As a part of the Transfer Institute students will save time and money by completing the freshman and sophomore years at Gavilan College. Students will also meet and get to know other students who share their goals and ambitions. Transfer Institute students receive:

- early registration
- a dedicated counselor to guide and monitor you through the transfer process
- pre-transfer events and activities with four-year universities
- access to activities designed to ensure your success at Gavilan College
- assistance with the identification of and preparation for a college major
- a two-year agreement guaranteeing transfer goals

A Transfer Institute application is on the last page of this schedule of classes. Contact the Counseling Department at 408-848-4723 for more information.

Tutoring Center The Tutoring Center is a place where students with diverse academic needs gather together to receive learning assistance. The basic philosophy of the Tutoring Center is to assist students in the improvement of their learning skills and understanding of course content. This is accomplished by providing students with an opportunity to discuss processes and concepts, share ideas, give examples and practice, and summarize their findings in a collaborative environment. The goal of the Tutoring Center is to guide students to independent learning.

Day and evening tutoring services are free to all Gavilan College students. The Tutoring Center is located in the Library (LI 116). For more information visit www.gavilan.edu/tutor or call (408) 848-838.

Writing Center The Gavilan College Writing Center fosters, celebrates and encourages writers.

Specially trained student assistants help writers start and strengthen class assignments as well as poetry, short stories, lyrics, business letters and resumes.

The center offers space for writing discussions, meeting, workshops and study groups. Special events include activities with acclaimed writers from our Visiting Writers and Scholars in Residence programs. The center collaborates with faculty to increase the likelihood of students' academic success, providing peer assistants for classes and labs and a variety of tools, strategies and approaches for writers.

Call (408) 848-4811 or drop by the center in LI 120 (the library building) for more information. The center is open Monday-Wednesday 8 am-6 pm (closed Monday 2:30-4:30 pm) Thursday 8 am-8 pm and Friday 8 am-1 pm.

Transfer

Students planning to transfer to a four-year institution can generally complete the first two years of their college work at Gavilan College and enter the four-year institution with junior standing.

The requirements of universities vary. It is therefore advisable that students consult a counselor early in the semester for more detailed information about each university's specific requirements. *Due to recent changes in admissions policies at UCs and CSUs, working with a counselor is critical.*

Transfer Credit Official transcripts from institutions which are fully accredited by appropriate accrediting associations will be evaluated for transferable lower division coursework. Appropriate units and subject content will be applied to major and general education requirements to meet prerequisites or graduation requirements. Courses taken at other California Community Colleges, California State Universities or any University of California will be transferred to Gavilan with the same general education designation as that of the issuing institution.

Students who wish to transfer coursework from foreign institutions must submit official transcripts to a college-approved foreign evaluation service for translation and evaluation.

Coursework from a foreign institution cannot be used for certification to a four-year institution. Students should contact the institution to which they wish to transfer to inquire about the acceptance of foreign coursework.

CLEP EXAMS: University of California does not grant credit for College Level Examination Program exams. CLEP credit CANNOT be used to certify IGETC. Some California State Universities will grant CLEP credit for certain areas and some will not grant credit at all. Transfer students are advised to contact the university they will be attending for specific information regarding CLEP credit.

Earn a Bachelor of General Studies Degree Online

GAVILAN COLLEGE

and

INDIANA UNIVERSITY

IN A QUANDRY about how to earn your bachelor's degree?

You've thought about an **online** degree but worry about "diploma mills."

You love where you live and wouldn't **dream** of leaving.

You'd attend a four-year **college** but can't just pull up stakes.

You're earning your associate degree and want to go on for a **bachelor's**.

Successfully complete at least 30 of the 120 required hours/units through Indiana University.

Sign up for the Independent

Learner Online Learn more about the General Studies Degree Program by signing up for the electronic newsletter, Independent Learner Online.

To subscribe, send an e-mail to gsd@indiana.edu. Provide your name and e-mail address.

Learn more. Talk to your Gavilan College counselor. Call 408-848-4723 for an appointment. Call 1-800-334-1011 to talk directly to an IU staff member.

Visit <http://scs.indiana.edu/undergraddegrees/9030program.html>.

Gavilan College and Indiana University have joined forces so that you can earn a bachelor's degree from the nation's "**Hottest Big State School**"—without leaving home!

- ▲ Stay with your job, family, and friends in your home town.
- ▲ Pay Indiana in-state tuition.
- ▲ Start your bachelor's degree when your schedule permits, and work at your own pace.

How 90 ► 30 Works

1. Earn 60 semester hours/units at your community college.
2. Apply for admission to IU. While you may apply to IU before earning an associate degree at Gavilan College, it is advisable to earn your degree before submitting your IU application.
3. Once admitted to IU, complete an additional 30 semester hours/units from Gavilan's curriculum.
4. Take your final 30 semester hours/units of upper-division courses via distance education at Indiana University, and join the thousands of students worldwide who have earned an IU Bachelor of General Studies.

What is the Bachelor of General Studies?

The Indiana University School of Continuing Studies offers a Bachelor of General Studies that you can complete entirely at a distance. There are no oncampus residency requirements.

- ▲ Take online courses and/or correspondence courses.
- ▲ Pay the same tuition as Indiana residents – no matter where you live.
- ▲ Earn your bachelor's degree from a fully accredited, Big Ten university.

You must complete a minimum of 120 semester hours/units to earn the Bachelor of General Studies.

You may transfer up to 90 semester hours/units toward your bachelor's degree, but you must successfully complete at least 30 of the 120 required hours/units through Indiana University.

As a general studies student, you pursue an interdisciplinary plan of study that encompasses arts and sciences:

- ▲ arts and humanities
- ▲ social and behavioral sciences
- ▲ mathematics and natural sciences

To graduate, you must have completed the required course work in these areas, plus an additional 66 semester hours/units of elective credit.

You interact with your IU instructors by email, phone, fax and postal mail, and receive academic counseling from experienced advisors who guide you through your course of study, as well as respond to your questions and concerns.

Why Indiana University?

- ▲ Newsweek, AMERICA'S HOT COLLEGES 2006 identified Indiana University as the nation's "hottest big state school."
- ▲ Intel® named Indiana University the nation's top wireless university in 2004.
- ▲ Time magazine called Indiana University "College of the Year" in 2001.
- ▲ In 2002, 2003, 2004, and 2005, U.S. News & World Report recognized Indiana University programs designed to help freshmen succeed.

Courses Numbered 22, 23, 122, 123, 98, 198

These courses are also called "Independent Studies", "Special Studies", "Special Topics", "Internships", etc. Credit for variable topics courses is given only after a review of the scope and content of the course by the receiving institution. This usually occurs after transfer and may require recommendations from faculty. Check with a counselor to prevent surprises.

Transfer Services

ASSIST: ASSIST is a computerized student-transfer information system that can be accessed over the World Wide Web. It displays reports of how course credits earned at one California college or university can be applied when transferred to another. ASSIST provides the most accurate and up-to-date information available about student transfer in California. Visit the website at www.assist.org.

CSU MENTOR: CSU Mentor is an online resource designed to help students and their families learn about the CSU system, select a CSU campus to attend, plan to finance higher education, and apply for admission. Personal data entered by the user is not released without the user's express consent and direction.

CSU Mentor is free to use. The student will only pay the application fee charged directly by the CSU campus when an application for admission is submitted. Visit the website at www.csumentor.org.

UC PATHWAYS: PATHWAYS, the University of California's online undergraduate admission information and application network.

- Information about financial aid and how to finance a UC education.
 - Answers for Transfers
 - UC campus Web sites, a list of links to the campuses for prospective students
 - Transfer/Application Center
 - Message Center - ask a question about undergraduate education or admission at UC
- Visit the website at <http://www.universityofcalifornia/admissions>

Transfer Agreements (TAA) A Transfer Admissions Agreement is a formal agreement between a student in attendance at Gavilan College and a receiving baccalaureate granting institution to which the student intends to transfer. The agreement guarantees admission to a transfer university a year in advance for the fall semester. It may also guarantee admission into a major.

Because the requirements of universities vary, it is advisable that students consult a counselor for more detailed information and to develop an educational plan.

Gavilan College has Transfer Admission Agreements with the following universities:

- UC Davis (beginning fall 2009)
- UC Merced
- UC Riverside
- UC Santa Cruz
- San Francisco State University
- San Jose State University
- CSU Monterey Bay
- University of Santa Clara

You do your part and they'll do theirs (admit you early!). Articulation agreements are also available online at www.assist.org. For eligibility requirements visit the Counseling/Transfer Services webpage at www.gavilan.edu/counseling/TransferServices.html or call 408-848-4723 to schedule a counseling appointment.

Career/Transfer Resource Center The center is located in SC102. See ad (page 125) or call 408-848-4818 for more information.

Transfer Institute See page 122 of this schedule.

Advanced Placement (AP) Gavilan College grants up to six semester units of transfer credit for each College Board Advanced Placement (AP) Test on which a student receives a score of 3 or better. The AP results must be submitted to the Office of Admissions & Records with a request for evaluation.

Students receiving a score of 3, 4 or 5 on the Math and English AP exams will be exempted from the placement assessment test. AP units will not apply toward financial aid, nor can they be used to satisfy the residency unit requirement.

Advanced Placement credit will be awarded as follows:

Examination	Score**	Equiv. Gav. College	Semester Units	IGETC Area
American History	3,4,5	HIST 1,2	6	3A or 3B*
Art History	3,4,5	ART 1A, 1B	6	3A or 3B
Biology	3,4,5	BIO 10	4	5B w/lab
Chemistry	3,4	CHEM 30A	4	5A w/lab
	5	CHEM 1A	5	5A w/lab 3B and 6A
Chinese and Language Culture				
Computer Science A	3,4,5	CSIS 45	3	
Computer Science AB	3,4,5	CSIS 45,46	6	
Economics, Macro	3,4,5	ECON 1	3	4B
Economics, Micro	3,4,5	ECON 2	3	4B
English Language & Composition	3,4,5	ENGL 1A	3	1A
English Composition & Literature	3,4	ENGL 1A	3	1A or 3B*
	5	ENGL 1A, 1B	6	1A or 3B*
(Max # Units in English= 6)				
Environmental Science				5A w/lab
European History*				4B or 4F*
French Language				3B and 6A
French Literature				3B and 6A
German Language				3B and 6A
Government & Politics:				
U.S.	3,4,5	POLS 1	3	4H
Comparative	3,4,5	POLS 3	3	4H
Human Geography				4E
Italian Language & Culture				3B and 6A
Japanese Language & Culture				3B and 6A
Latin Literature				3B and 6A
Latin: Vergil				3B and 6A
Math/Calc AB	3,4,5	MATH 1A	4	2A
Math/Calc BC	3,4,5	MATH 1B	4	2A
Math/Statistics	3,4,5	MATH 5	3	2A
Music Theory	3,4,5	MUS 3A	3	
Physics B	3,4,5	PHYS 2A	4	5A w/lab
Physics C Mechanics	3,4,5	PHYS 4A	4	5A w/lab
Physics C Electricity/Magnetism	3,4,5	PHYS 4B	4	5A w/lab
Psychology	3,4,5	PSYC 1A	3	4I
Spanish	3,4	SPAN 1B	5	
	5	SPAN 2A	5	3B and 6A 3B or 4F
World History				

* AP exams may be used in either area regardless of where the certifying CCC's discipline is located. Example: US History at a CCC is approved for Area 3B. The US History AP may be used in either Area 3B or 4F.

** Scores of "3" may not be accepted for all courses by some 4 year colleges and universities.

Articulation Agreements Gavilan College has completed lower division course-to-course, major-to-major and general education agreements with all California State University (CSU), University of California (UC) and a number of private university campuses. These agreements ensure that participating universities will accept certain courses taken at Gavilan College to satisfy general education, major or elective university requirements.

The articulation officer, counselors and the Career/Transfer Resource Center staff have lists of participating institutions. Articulation agreements are also available online. See information on www.assist.org.

Note: Educational plans for students preparing to transfer to any public or private institution can be developed.

California Articulation Number System

The California Articulation Number (CAN) System provides a cross reference number for courses which have been evaluated by faculty and determined to be acceptable "in lieu of" each other. Only lower division, transferable, major preparation courses commonly taught on two- and four-year college and university campuses are included in the System.

The criteria for a campus to qualify to use a CAN Number includes written, faculty-approved articulation agreements on each course with a minimum of four public four-year California colleges and universities.

The CAN Number System is not a common numbering system. Each campus retains its own course numbers, prefixes and titles. The CAN (e.g., CAN ENGL 2) is listed parenthetically in catalog descriptions, class schedules and other publications as appropriate.

The CAN designation is assurance that the course or sequence of courses will be accepted in lieu of an identically designated CAN course or sequence at all participating campuses in California.

(CAN ENGL1A = CAN ENGL 1A at another college.)

Visit the Career/Transfer Resource Center

Services are designed to assist you throughout your time at Gavilan College.

- ◆ Information on career outlook, training and educational opportunities
- ◆ Career Assessment using EUREKA
- ◆ College Fair and Career Fair
- ◆ Transfer information
- ◆ Workshops
- ◆ Articulation agreements using ASSIST
- ◆ College and university catalogs
- ◆ Assistance with admission procedures and referral to academic counseling
- ◆ Library of career reference materials
- ◆ Online Job Search/Research Portal

Located in SC102, on the main campus
For more information call 408-848-4818
or visit the website at www.gavilan.edu/transferctr

Please see your counselor for additional information and to view copies of specific transfer agreements. The Counseling Office is located in SC108. For more information call 408-848-4723.

Intersegmental General Education Transfer Curriculum

(IGETC) The IGETC can be used by community college transfer students to fulfill lower division general education requirements for either the CSU or UC system without the need, after transfer, to take additional lower division general education courses, as long as your IGETC completion is certified at the community college. Obtain the Certification form from Admissions and Records.

Students are strongly encouraged to complete all IGETC requirements prior to transfer.

PARTIAL IGETC - If you are approaching readiness for transfer and are unable to complete one or two IGETC courses, you may be eligible to complete IGETC after transferring.

Warning: Students need Area 1 and 2 completed to meet minimum transfer admission requirements. Therefore, partial certification that acknowledges a deficiency in Area 1 and/or 2 may also indicate a student does not meet minimum transfer requirements. Community colleges should make every effort to notify students of this potential problem.

If your petition for partial certification of IGETC is approved, you may be able to complete IGETC in one of the following ways:

- 1) Take an approved IGETC course, in the area(s) to be completed, at any California Community College, at a time that does not require concurrent enrollment, such as during the summer.
- 2) Take a course approved by the UC or CSU campus of attendance in the area(s) to be completed at a U.S. regionally accredited institution at a time that does not require concurrent enrollment, such as during summer school.
- 3) Take an approved IGETC course, in the area(s) to be completed, at any

California Community College while concurrently enrolled at a UC or CSU campus. The student will be subject to the UC or CSU campus rules regarding concurrent enrollment, so this option may not be available.

- 4) Take a course approved by the UC or CSU campus of attendance at a United States regionally accredited institution in the area(s) to be completed while concurrently enrolled at a UC or CSU campus. The student will be subject to the UC or CSU campus rules regarding concurrent enrollment, so this option may not be available.
- 5) Take a comparable course at a UC or CSU campus in the area(s) to be completed. This option is at the discretion of each UC or CSU campus, so it may not be a choice available to the student.

You will be expected to complete IGETC before the beginning of the second full year of enrollment at your UC or CSU campus. Check with your campus advisor after you transfer for more information, including which options are available and which UC or CSU courses may be comparable to the IGETC courses remaining to be completed.

All UC and CSU campuses will accept IGETC with the exception of Fifth and Revelle Colleges at UC, San Diego. Since all majors are available at each of the five colleges at UC, San Diego, students will not be restricted in their choice of major if they use the IGETC.

A course cannot be used to satisfy more than one subject area of the IGETC (general education). However, major prerequisite courses can be used (double counted) to satisfy IGETC requirements.

CSU campuses' limitations on double counting of general education courses toward major preparations are not changed by IGETC.

Students who wish to be certified for both CSU and UC systems should take CMUN 1A, 8 or 10 in Area 1 for CSU and meet the foreign language requirement for UC. Completing both provides flexibility and choices.

The courses for all IGETC areas must be completed with a grade of "C" or better before IGETC can be certified. A grade of "C-" is not acceptable.

UC/CSU Intersegmental General Education Transfer Curriculum IGETC - 2007-2008

Completion of all the requirements in the IGETC will permit a student to transfer from a community college to the California State University or the University of California without the need, after transfer, to take additional lower-division general education courses to satisfy campus general education requirements. All areas must be satisfied, and all courses must be completed with a grade of "C" or better before the IGETC can be certified. See requirements for partial IGETC certification in catalog. A student is strongly advised to complete a total of 60 transferable units before transferring. These will include the IGETC requirements, "major" prerequisites, and elective courses if needed.

(Students should request an IGETC certification from the Office of Admissions and Records before transferring.)

AREA 1	AREA 3	
<p>ENGLISH COMMUNICATION CSU - 3 courses required, one each from Group A, B, and C UC - 2 courses required, one each from Group A and B</p> <p>1-A English Composition ENGL 1A Composition (3)</p> <p>1-B Critical Thinking / English Composition ENGL1C Critical Reasoning and Writing (3) PHIL 4 Critical Thinking and Writing (3)</p> <p>1-C Oral Communication (CSU requirement only) CMUN1A Introduction to Public Speaking (3) CMUN 5 Fund of Com Studies (3) CMUN 8 Interpersonal Communication (3) CMUN 10 Small Group Communication (3)</p>	<p>ARTS AND HUMANITIES At least 3 courses, with at least one course from the Arts and one course from the Humanities.</p> <p>3-A Arts ART 1A,B Art History (3) (3) ART 6 Art Appreciation (3) ART 20 Art of Asia (3) ART 21 Ancient Americas: A History Through Art (3) HIST 21 Ancient Americas: A History Through Art (3) HUM 6 Foreign Cinema (3) MUS 1A,B Music History and Literature (3) (3) THEA 1 Theater History (3) THEA 3 El Teatro Campesino (3) THEA 7 Theater Appreciation</p> <p>3-B Humanities ENGL 1B Composition and Literature (3) ENGL 2A Introduction to Poetry (3) ENGL 2B Intro to Multi-Cultural Literature (3) ENGL 2C Introduction to Film and Fiction (3) ENGL 2D Introduction to the Study of Fiction (3) ENGL 2E Introduction to Women Writers (3) ENGL 2F Childrens's Literature ** (3) ENGL 2H Mexican-American Literature (3) ENGL 2I Intro to Native American Literature (3) ENGL 2J Mythology (3) ENGL 4A British Literature - 449 through 1798 (3) ENGL 4B British Literature - 1798 to present (3) ENGL 5A Survey of American Literature - 1620 - 1865 (3) ENGL 5B Survey of American Literature - 1865 to present (3) * HIST 1 U.S. Hist through Reconstruction (3) * HIST 2 U.S. Hist Reconstrucion to Present (3) * HIST 3 History of California (3) * HIST 4A Hist of World Societies Before 1500 (3) * HIST 4B History of World Societies - 1500 to Present (3) * HIST 5 Women's Lives in Early U.S. Hist (3) * HIST 6 Women's Lives in Recent U.S. Hist (3) HIST 7A History of Western Civilization (3) HIST 7B History of Western Civilization (3) * HIST 10 African American History (3) * HIST 12 CultHist. of the Mexican American (3) * HIST 14 U.S. in the 20th Century: An Oral History Approach (3)</p>	<p>* HIST 18 Our American Experience I (3)* HIST 19 Our American Experience II (3) HUM 3 Introduction to the Cinema (3) HUM 4 Intro to the American Cinema (3) HUM 5 Humanities Through the Arts (3) HUM 10 Approaches to Contemporary Film (3) PHIL 1 Introduction to Philosophy (3) PHIL 3A Ethics (3) PHIL 3B Contemporary Moral Issues (3) PHIL 6A Comparative Religions (3) PHIL 6B Philosophy of Religion (3) PHIL 7A History of Philosophy: Ancient to Medieval (3) PHIL 7B History of Philosophy: Renaissance to Modern (3) PHIL 8 Intro to the Philosophy of Science (3) PHIL 15 Asian Philosophies (3) * SPAN 2A,B Intermediate Spanish (5) (5) SPAN 9A Spanish for Spanish Speakers ** (3)</p>
AREA 2		AREA 4
<p>MATHEMATICAL CONCEPTS AND QUANTITATIVE REASONING 1 course, 3 semester, 4-5 quarter units</p> <p>2-A Math CSIS 26 Discrete Mathematics (4) + ECON 11 Statistics for Business & Economics (4) + GBUS 11 Statistics for Business & Economics (4) + MATH 1A Single Variable Calculus & Analytic Geometry (4) MATH 1B Single Variable Calculus & Analytic Geometry (4) MATH 1C Multivariable Calculus (4) MATH 2 Linear Algebra (3) MATH 2C Differential Equations (3) MATH 5 Introductions to Statistics (3) + MATH 6 Calc for Bus / Social Sci (3) MATH 7 Finite Mathematics (3) + MATH 8 Precalculus (5) + MATH 8A First Half of Precalculus (4) + MATH 8B Second Half of Precalculus (4) + MATH 9 College Algebra and Trig ± (5) + MATH 10 Functional Analysis and Mod ± (3) MATH 14 Math for the Liberal Arts (3) MATH 26 Discrete Math (4)</p>		<p>SOCIAL AND BEHAVIORAL SCIENCES Three courses from at least two disciplines or an interdisciplinary sequence. 9 semester, 12-15 quarter units.</p> <p>4-A Anthropology and Archeology ANTH 2 Introduction to Archeology (3) ANTH 3 Intro to Cultural Anthropology (3) ANTH 5 Magic, Witchcraft and Religion (3) ANTH 8 Intro to New World Archeology ** (3) ANTH 10 Native American Culture (3)</p> <p>4-B Economics + ECON 1 Principles of Macroeconomics (3) + ECON 2 Principles of Macroeconomics (3) + ECON 10 Fundamentals of Economics (3)</p> <p>4-E Geography GEOG 2 Cultural Geography (3)</p> <p>4-F History * HIST 1 U.S.Hist through Reconstruction (3) * HIST 2 United States History: Reconstruction to the Present (3) * HIST 3 History of California (3) * HIST 4A History of World Societies Before 1500 (3)</p>

<p>4-F History - Cont. * HIST 4B History of World Societies 1500 to Present (3) * HIST 5 Women's Lives in Early U.S. Hist. (3) * HIST 6 Women's Lives in Recent U.S. History (3) * HIST 10 African American History (3) * HIST 12 Cultural Hist of the Mexican American (3) * HIST 14 U.S. in the 20th Century: An Oral History Approach (3) * HIST 18 Our American Experience I (3) * HIST 19 Our American Experience II (3)</p> <p>4-G Interdisciplinary, Social & Behavioral Science CMUN 4 Intercultural Communication (3) SSCI 1 Introduction to Social Sciences (3)</p> <p>4-H Political Science, Government & Legal Institutions PHIL 12 Intro to Political Thought (3) POLS 1 Intro to American Government (3) POLS 3 Intro to Comparative Politics (3) POLS 4 Intro to International Relations (3) POLS 12 Introduction to Political Thought (3)</p> <p>4-I Psychology CD 2 Early Childhood Development (3) CD 3 Child Growth and Development During the School Years (3) PSYC 1A,B Introduction to Psychology (3)(3) PSYC 2 Early Childhood Development (3) PSYC 3 Child Growth and Development During the School Years (3)</p> <p>4-J Sociology & Criminology JOUR 10 Mass Media and Society (3) SOC 1A Introduction to Sociology (3) SOC 1B Intro to Sociology: Social Problems (3) SOC 3 Sociology of Race, Ethnicity and Cultural Identity (3) SOC 4 Sociology of Women and Men (3) SOC 10 Mass Media and Society (3)</p>	<p>+ CHEM 30A Elementary Chemistry (4) CHEM 30B Elementary Organic Biochemistry(4) GEOG 1 Physical Geography (3) GEOL 1 Introduction to Geology (4) GEOL 13 Environmental Geology ** (3) + PHYS 1 Introduction to Physics (4) + PHYS 2A General Physics (4) + PHYS 2B General Physics (4) + PHYS 4A Physics for Scientists and Engineers (Mechanics/Fluids/Waves) (4) + PHYS 4B Physics for Scientists and Engineers (Electromagnetism) (4) + PHYS 4C Physics for Scientists and Engineers (Thermodynamic/Optics/Moderns Physics) (4) + PSCI 1 Principles of Physical Science (3) PSCI 2 Introduction to Meteorology (3)</p> <p>5B Biological Science AH 8 General Microbiology (5) + AH 9 Human Physiology (5) + AH 15 Survey of Human Anatomy and Physiology (5) ANTH 1 Intro to Physical Anthropology (3) BIO 1 General Biology (4) BIO 4 General Zoology (4) BIO 5 General Botany (4) + BIO 7 Human Anatomy (4) BIO 8 General Microbiology (5) + BIO 9 Human Physiology (5) + BIO 10 Principles of Biology (4) BIO 13 Marine Biology (4) + BIO 15 Survey of Human Anatomy and Physiology (5) ECOL 1 Conservation of Natural Resources(4) + Transfer credit may be limited by either UC or CSU or both. Please consult with a counselor.</p>	<p>CSU Graduation Requirement in U.S. History, Constitution and American Ideals.</p> <p>Not Part of IGETC (May be completed prior to transfer.) For the baccalaureate degree, CSU requires one of the following combinations: HIST 1 & 2, HIST 1 & 19, HIST 2 & 18: POLS 1 with either HIST 1, 2, 18 or 19 CSU campuses have the discretion whether to allow courses used to satisfy the CSU US History, Constitution and American Ideals (AI) graduation requirement to count in both Area 3B or 4F and to meet the graduation requirement.</p>
<p>AREA 5</p>	<p>AREA 6</p>	<p>SUPPLEMENTARY NOTES</p>
<p>PHYSICAL AND BIOLOGICAL SCIENCES At least 2 courses, one Physical Science course and one Biological Science course; At least one must include a laboratory. Courses in BOLD include a laboratory component. 7-9 semester, 9-12 quarter units</p> <p>5-A Physical Science ASTR 1 Intro to General Astronomy (3) CHEM 1A General Chemistry (5) CHEM 1B General Chemistry (5) CHEM 12A Organic Chemistry (5) CHEM 12B Organic Chemistry (5)</p>	<p>LANGUAGE OTHER THAN ENGLISH (UC REQUIREMENT ONLY) Proficiency equivalent to two years of high school study in the same language.</p> <p>6-A Language Other Than English FRNH 1B Elementary French (5) JPN 1B Elementary Japanese (5) * SPAN 1B Elementary Spanish (5) * SPAN 2A,B Intermediate Spanish (5)(5) * SPAN 12A Spanish for Spanish Speakers (5) * SPAN 12B Spanish for Spanish Speakers - Intermediate / Advanced (5) * Courses listed in multiple areas shall not be certified in more than one area except for courses in Languages Other Than English, which can be certified in both areas 3B and 6A.</p>	<p>1. A single course, even though listed in more than one place, can only be used to satisfy one subject area of the IGETC. 2. IGETC is not advisable for high-unit majors, e.g. sciences, engineering. 3. Eleanor Roosevelt and Revelle Colleges at UC San Diego do not accept the IGETC. 4. IGETC may not be appropriate for students who have completed courses at a CSU or UC campus. 5. "Double counting" of courses toward the major is not limited by the IGETC, but may be limited by other directives. The UC will also allow IGETC courses to count toward major requirements. CSU campus limitations on double-counting of general education courses toward major preparation are not changed by the IGETC.</p> <p>+ Transfer credit may be limited by either UC or CSU or both. Please consult with a counselor. ** Approved for Fall, 2007 □ Approved retroactively for Fall, 1999. ± Approved retroactively for Fall, 1999.</p>

The Gavilan Community College district assumes no liability for loss or damage of student personal property.

CSU General Education (Breadth) Requirements 2007-2008

certified by Gavilan College

Students transferring to the California State University system will qualify for admission as upper division transfers if they have completed (60) transferable units with a GPA of 2.0 ("C") or better (non-residents 2.4 or better). Within the (60) unit requirement, the (9) units in Area A, Area B-4 (Mathematics), and (18) additional semester units of general education coursework must be completed with a grade of 2.0 or better in each course. Students who complete the following pattern will have satisfied the lower division General Education requirements for the California State University BA / BS degree. A minimum of (9) semester units of General Ed coursework must be completed at the upper division level after transfer; some CSU campuses require more than (9) units. (See a counselor for further information.) (Students should request a general education certification from the office of Admissions and Records before transferring.)

AREA A	B - 2 LIFE SCIENCE	ART 6 Art Appreciation (3)		
<p>COMMUNICATION IN THE ENGLISH LANGUAGE AND CRITICAL THINKING Select one course from each category. All courses must be completed with a grade of "C" or better. 9 semester units or 12-15 quarter units</p> <p>A - 1 ORAL COMMUNICATION CMUN 1A Introduction to Public Speaking (3) CMUN 5 Fundamentals of Comm Studies (3) CMUN 8 Interpersonal Communication (3) CMUN 10 Small Group Communication (3)</p> <p>A - 2 WRITTEN COMMUNICATION ENGL 1A Composition (3)</p> <p>A - 3 CRITICAL THINKING ENGL 1C Critical Reasoning and Writing (3) PHIL 2 Logic (3) PHIL 4 Critical Thinking and Writing (3)</p>	ANTH 1 Intro to Physical Anthropology (3) ECOL 1 Conservation of Natural Resources(4) BIO 1 General Biology (4) BIO 4 General Zoology (4) BIO 5 General Botany (4) BIO 7 Human Anatomy (4) BIO 8 General Microbiology (5) BIO 9 Human Physiology (5) BIO 10 Principles of Biology (4) BIO 13 Marine Biology (4) BIO 15 Survey of Human Anatomy and Physiology (5) BIO 20 Field Biology (4)	ART 8A Beginning Photography From Analog to Digital (3) ART 10A Cultural History of Ceramics (3) ART 13 Three Dimensional Design (3) ART 14 Beginning Mural Painting (3) ART 20 Art of Asia (3) ART 21 Ancient Americas: A History Through Art (3) HIST 21 Ancient Americas: A History Through Art (3) ART 25A Art Methods (3) CD 25A Art Methods (3) CMUN 2 Oral Reading (3) THEA 4 Oral Reading (3) HUM 6 Foreign Cinema (3) HUM 10 Approaches to Contemporary Film (3) MUS 1A, B Music, History, and Literature (3) MUS 3A Harmony-Theory-Musicianship (4) MUS 4A Beginning Piano (3) THEA 1 Theater History (3) THEA 3 El Teatro Campesino (3) THEA 7 Theater Appreciation (3) THEA 12A Acting: History and Practice (3) THEA 20 Introduction to Script Writing (3)		
	AREA B	B - 3 LABORATORY ACTIVITY See Areas B - 1 & B - 2 above	C - 2 Humanities (Literature, Philosophy, Foreign Language)	
	<p>PHYSICAL UNIVERSE AND ITS LIFE FORMS One course from each category. The Physical or Life Science course must include a laboratory (indicated in BOLD). 9 semester units or 12-15 quarter units</p> <p>B - 1 PHYSICAL SCIENCE ASTR 1 Intro to General Astronomy (3) CHEM 1A,B General Chemistry (5) (5) CHEM 12A,B Organic Chemistry (5) (5) CHEM 30A Elementary Chemistry (4) CHEM 30B Elementary Organic Biochemistry (4) GEOG 1 Physical Geography (3) GEOL 1 Introduction to Geology (4) GEOL 13 Environmental Geology (3) PHYS 1 Introduction to Physics (4) PHYS 2A, B General Physics (4)(4) PHYS 4A Physics for Scientists & Engineers (Mechanics / Fluids / Waves) (4) PHYS 4B Physics for Scientists and Engineers (Electromagnetism) (4) PHYS 4C Physics for Scientists & Engineers (Thermodynamic / Optics Moderns Physics) (4) PSCI 1 Principles of Physical Science (3) PSCI 2 Introduction to Meteorology (3)</p>	MATH 1A, B Single-Variable Calculus and Analytic Geometry (4) (4) MATH 1C Multivariable Calculus (4) MATH 2 Linear Algebra (3) MATH 2C Differential Equations (3) MATH 5 Introductions to Statistics (3) MATH 6 Calculus for Bus / Social Science (3) MATH 7 Finite Mathematics (3) MATH 8 Precalculus (5) MATH 8A First Half of Precalculus (4) MATH 8B Second Half of Precalculus (4) MATH 9± College Algebra & Trigonometry (5) MATH 10± Functional Analysis and Modeling (3) MATH 12 Math for Elementary Teachers (3) MATH 14 Math for the Liberal Arts (3) MATH 26 Discrete Math (4) CSIS 26 Discrete Math (4) ECON 11 Statistics for Bus and Econ (4) GBUS 11 Statistics for Bus and Econ (4)	ART 11 Creativity, Imagination, & Innovation(3) ART 21 Ancient Americas: A History Through Art (3) HIST 21 Ancient Americas: A History Through Art (3) ENGL 2A Introduction to Poetry (3) ENGL 2B Introd to Multi-Cultural Literature (3) ENGL 2C Intro to Film and Fiction (3) ENGL 2D Intro to the Study of Fiction (3) ENGL 2E Introduction to Women Writers (3) ENGL 2F Children's Literature* (3) ENGL 2H Mexican-American Literature (3) ENGL 2I Intro to Native American Literature (3) ENGL 2J Mythology (3) ENGL 4A British Literature - 449 through 1798 (3) ENGL 4B British Literature - 1798 to present (3) ENGL 5A Survey of American Literature - 1620 - 1865 (3) ENGL 5B Survey of American Literature - 1865 to present (3) ENGL 9A Introduction to Creative Writing (3) ENGL 9B Advanced Creative Writing (3) ENGL 9C Poetry Writing (3) FRNH 1A, B Elementary French (5) (5)	
			AREA C	
			ARTS, LITERATURE, PHILOSOPHY & FOREIGN LANGUAGE	
			Required: English 1B, one course from C-1 and one course from C-2	
			9 semester units or 12-15 quarter units	
			C - 1 Arts (Art, Dance Music, Theater) Minimum of 2 units from one of these courses.	
			ART 1A, B Art History (3) (3)	
			ART 2A Two Dimensional Design (3)	
			ART 3A Drawing and Composition (3)	

<p>C - 2 Humanities (continued)</p> <p>HIST 1 U.S. Hist through Reconstruction (3) HIST 2 United States History - Reconstruction to the Present (3) HIST 3 History of California (3) HIST 4A History of World Societies Before 1500 (3) HIST 4B History of World Societies Before 1500 (3) HIST 5 Women's Lives in Early U.S. History (3) HIST 6 Women's Lives in Recent U.S. History (3) HIST 7A, B History of Western Civilization (3) (3) HIST 10 African American History (3) HIST 12 Cult Hist of the Mexican American (3) HIST 14 U.S. in the 20th Century: An Oral History Approach (3) HIST 18 Our American Experience I (3) HIST 19 Our American Experience II (3) HUM 3 Introduction to the Cinema (3) HUM 4 Intro to the American Cinema (3) HUM 5 Humanities Through the Arts (3) HUM 10 Approaches to Contemporary Film (3) JPN 1A, B Elementary Japanese ±± (5) (5) SPAN 1A, B Elementary Spanish (5) (5) SPAN 2A, B Intermediate Spanish (5) (5) SPAN 9A Spanish for Spanish Speakers (3) SPAN 12A Spanish for Spanish Speakers (5) SPAN 12B Spanish for Spanish Speakers Intermediate/Advanced (5) JOUR 10 Mass Media and Society (3) SOC 10 Mass Media and Society (3) PHIL 1 Introduction to Philosophy (3) PHIL 3A Ethics (3) PHIL 3B Contemporary Moral Issues (3) PHIL 6A Comparative Religions (3) PHIL 6B Philosophy of Religion (3) PHIL 7A Hist of Philosophy: Ancient to Medieval (3) PHIL 7B History of Philosophy: Renaissance to Modern (3) PHIL 8 Intro to the Philosophy of Science (3) PHIL 15 Asian Philosophies (3)</p>	<p>NOTE: For the baccalaureate degree, one of the following combinations will satisfy the CSU graduation requirement in US History, Constitution and American Ideals:</p> <p>HIST 1 & 2, HIST 1 & 19, HIST 2 & 18, POLS 1 with either HIST 1, 2, 18, or 19.</p> <p>Requirement 2:</p> <p>D - 1 Anthropology and Archeology ANTH 2 Introduction to Archeology (3) ANTH 3 Intro to Cultural Anthropology (3) ANTH 5 Magic, Witchcraft and Religion (3) ANTH 8 Intro to New World Archeology (3) ANTH 10 Native American Culture (3)</p> <p>D - 2 Economics ECON 1 Principles of Macroeconomics (3) ECON 2 Principles of Microeconomics (3) ECON 10 Fundamentals of Economics (3)</p> <p>D - 3 Ethnic Studies CMUN 4 Intercultural Communication (3) HIST 10 African American History (3) HIST 12 Cultural History of the Mexican American (3) SOC 3 Sociology of Race, Ethnicity & Cultural Identity (3)</p> <p>D - 4 Gender Studies HIST 5 Women's Lives in Early U.S. Hist. (3) HIST 6 Women's Lives in Recent U.S. Hist. (3) SOC 4 Sociology of Women and Men (3)</p> <p>D - 5 Geography GEOG 2 Cultural Geography (3)</p> <p>D - 6 History HIST 1 U.S. Hist through Reconstruction (3) HIST 2 United States History - Reconstruction to the Present (3) HIST 3 History of California (3) HIST 4A History of World Societies Before 1500 (3) HIST 4B History of World Societies Before 1500 to Present (3) HIST 5 Women's Lives in Early U.S. Hist. (3) HIST 6 Women's Lives in Recent U.S. Hist. (3) HIST 10 African American History (3) HIST 12 Cultural History of the Mexican American (3) HIST 14 U.S. in the 20th Century An Oral History Approach (3) HIST 18 Our American Experience I (3) HIST 19 Our American Experience II (3)</p> <p>D - 7 Interdisciplinary Social & Behavioral Sci. ANTH 9 Cultural Context of Childhood (3) CMUN 4 Intercultural Communication (3) PSYC 6 Conflict Resolution (3)</p>	<p>AJ 6 Intro to Conflict Resolution (3) POLS 6 Intro to Conflict Resolution (3) PSYC 7 Cultural Context of Childhood (3) CD 7 Cultural Context of Childhood (3) SSCI 1 Introduction to Social Sciences (3)</p> <p>D - 8 Political Science, Government and Legal Institutions POLS 1 Intro to American Government (3) POLS 3 Intro to Comparative Politics (3) POLS 4 Intro to International Relations (3) POLS 12 Introduction to Political Thought (3) PHIL 12 Introduction to Political Thought (3)</p> <p>D - 9 Psychology PSYC 1A, B Intro to Psychology (3) (3) PSYC 2 Early Childhood Development (3) PSYC 3 Child Growth and Development During the School Years (3) CD 2 Early Childhood Development (3) CD 3 Child Growth and Development During the School Years (3)</p> <p>D - 0 Sociology and Criminology SOC 1A Introduction to Sociology (3) SOC 1B Introduction to Sociology: Social Problems (3) SOC 3 Sociology of Race, Ethnicity and Cultural Identity (3) SOC 4 Sociology of Women and Men (3) SOC 10 Mass Media and Society (3) JOUR 10 Mass Media and Society (3)</p>
AREA E		
<p>LIFE-LONG UNDERSTANDING AND SELF-DEVELOPMENT</p>		
<p>1. One unit of Physical Education activity course</p>		
<p>2. Two units from:</p>		
<p>AH 3 The Person in the Life Cycle (3) AH 11 Nutrition (3) BIO 11 Nutrition (3) GUID 6 Life Skills for Higher Education (2) HE 1 Health Education (3) HE 2 Human Sexuality (3) PSYC 5 Self-Assessment and Career Development (2) GUID 1 Self-Assessment and Career Development (2) □ PSYC 2 Early Childhood Development (3) □ PSYC 3 Child Growth and Development During the School Years (3) » CD 2 Early Childhood Development (3) » CD 3 Child Growth and Development During the School Years (3) PSYC 41 Psychology of Adjustment (2) SOC 21 Marriage and the Family (3)</p>		
<p>Courses listed under more than one discipline or area may be used only once to satisfy an area.</p>		
<p>* = Approved for Fall 2006 ± = Approved Retroactively for Fall 1999, ±± = Approved retroactively for Fall 2005.</p>		
<p>NOTE: "x" or "»" . PSYC 2 + 3 acceptable for AREA E only if taken as combination.</p>		
<p>NOTE: Transfer credit of certain courses (especially Science and Math) may be limited by UC or CSU or both. Consult with a counselor.</p>		
<p>AREA D</p>		
<p>SOCIAL, POLITICAL AND ECONOMIC INSTITUTIONS</p>		
<p>Two requirements: select one course from Requirement 1 and select 2 courses from Requirement 2.</p>		
<p>9 semester units or 12-15 quarter units</p>		
<p>Requirement 1:</p>		
<p>HIST 1 U.S. Hist through Reconstruction (3)</p>		
<p>HIST 2 U.S. Hist Reconstruction to the Present (3)</p>		
<p>HIST 18 Our American Experience I (3)</p>		
<p>HIST 19 Our American Experience II (3)</p>		
<p>POLS 1 Intro to American Government (3)</p>		

General Information

Attendance Students who fail to attend the first class session may be dropped by the instructor. Generally, students missing one more class hour than the unit value for that course, without making prior arrangements, may be dropped without the possibility of credit. However, a student should not assume that he or she will be dropped by the instructor; it is the responsibility of the student to make sure that courses are officially dropped.

Advisories Course advisory is recommended preparation for a course. It is not a prerequisite to taking a course but is strongly suggested that the advisory be met prior to enrollment as success in the course may depend upon having that skill or knowledge level. For example, a course advisory that reads "to be eligible for English 250 and English 260 in order to enroll in Psychology 1A" strongly recommends that you have successfully completed (with a "C" grade or better or a "credit") the previous courses, English 440 and English 260. This becomes critical in being able to read and understand college textbooks.

Campus Safety and Crime Statistics Contact the Gavilan College Security Dept. at 408-710-7490 (or dial "10" from any campus extension) to report criminal or potential criminal activity. For non-emergency calls, you may call the security office at 408-848-4703.

Campus safety information and crime statistics are available online at www.gavilan.edu/safety. If you would like a hard copy of this information, copies are available at Admissions and Records (SC111) and the Campus Security office (S/M bldg.) or call 408-848-4703 to have a copy mailed to you.

Course Repetition Course Repetition There are limitations on the number of times a student may repeat a course. All courses listed in this publication with no repeat notation following the description may be repeated once without filing a petition if a grade of D, F, or NC was earned. A student may file a petition to repeat a course a second time if a grade of D, F, or NC is earned again. To file a petition, the student must meet with a counselor to evaluate circumstances and receive written approval. The student's transcript and grade point average will reflect the last grade the student receives in the course. A student may petition to repeat the course a third time by filing a Request to Repeat a Course Under Special Circumstances and providing the necessary documentation to support the special circumstances claim.

To repeat a course in which the student has received a final grade of "C" or better, a student must file a Request to Repeat a Course Under Special Circumstances prior to registering for the course again. Units and grade points for the repeated course are not computed in the grade point average unless the course is being repeated to meet legally mandated training requirements as a condition of continued paid or volunteer employment. This request must also be approved by a counselor.

Pass/No Pass, Letter Grade Option For some courses, students have the option of selecting a final grade of Pass/No Pass or a traditional letter grade of "A", "B", "C", etc. Review the course description in this schedule to determine which courses are designated as having this grading option.

Before selecting a grading option, students should consider the following:

- Once the option has been selected, the student's decision is final and irreversible.
- To select one option over another, a student must complete the Grading Option form and file it with the Admissions & Records Office or indicate a preference when registering online prior to the NRS (No Record Shown) date for the course. This date is either the end of the fourth week (for a semester-long course) or 30% of the course meetings (for a short-term course.)
- If the student opts for a P/NP final grade, the units are not included in the semester GPA but are considered for the purposes of academic and progress probation and dismissal.
- A P/NP grade is not used in consideration of honors.

- A total of 20 units of P/PN graded units (not including those courses required by the major which are designated P/NP only) may be applied to an Associates's Degree or Certificate.
- The student should carefully consider the transferability of P/NP units to other institutions. Some universities may not accept any credit/no credit courses and others limit the amount of credit/no credit units that will be accepted. Please consult your counselor before selecting the pass/no pass option.

Prerequisites and Co-requisites A prerequisite is a course or skill level that is required before you can enroll in another course. For example, English 250 is a prerequisite for English 1A. Courses used to meet prerequisite requirements must have been completed with a "C" grade or better or "credit".

A co-requisite is a set of courses that you must take at the same time.

If you believe that you have the equivalent of the prerequisite through another means (courses at another college, AP tests, work experience, etc.) speak with your counselor.

CHALLENGING A PREREQUISITE

Students who believe that they have already fulfilled a prerequisite, or that a prerequisite has been improperly established or implemented, may challenge the prerequisite. The student is responsible for providing compelling evidence to substantiate the challenge based on one of the following:

- The prerequisite course has not been made reasonably available.
- The prerequisite was established in violation of regulation or in violation of the District-approved processes.
- The prerequisite is in violation of this Article.
- The prerequisite is discriminatory or is applied in a discriminatory manner.
- The student has the knowledge or ability to succeed in the course despite not meeting the prerequisite.

Challenge forms are available in the Admissions & Records Office or from a counselor and must be completed and returned to the Vice President of Instruction prior to the first day of classes.

Transcripts Transcripts of a student's permanent academic record are released ONLY with written authorization of the student. Telephone requests will not be accepted. The first two copies are free; there is a \$4 charge for each copy thereafter. Transcripts are normally sent out within five days of the request. This response time may be longer during busy periods such as the first two weeks of a new semester. Urgent requests cannot be honored during the late registration period but can normally be produced within an hour at a cost of \$7 per copy.

Unofficial transcripts are available to students on the Gavilan College homepage. Click on the Self-Serve Banner icon.

Withdrawal *It is anticipated that the following policy will be in effect for Fall 2008.*

Students may withdraw from a course by notifying Admissions & Records either online or in person. The following grading practices apply when withdrawing from a course:

- A student who withdraws from a course prior to 30% of the class meetings being held will receive no grade of record.
- A student may withdraw from a course and receive a grade of "W" prior to completion of 75% of the class meetings for the course; thereafter, the student will receive whatever grade they would have earned, based upon the entire semester's work.
- A student may withdraw from a course up to four times and receive a grade of "W"; after a fourth "W", the student will receive the grade they would have earned, based upon the entire semester's work.
- A withdrawal may be excluded from the four-time maximum limit in the case of extenuating circumstances such as natural disasters or other circumstances beyond the control of the student including verified cases of accident or illness.

Student Life

Associated Student Body (ASB) The ASB is the official student organization on campus and provides the majority of student input and recommendations on critical campus issues to faculty, staff, administration and the Board of Trustees.

The Student Senate is a representative body of students who meet weekly to plan, implement and evaluate college activities and services that meet the needs of Gavilan College students. Any student who meets the requirements of the ASB's by-laws may become a voting member of the Student Senate. The elected and appointed officers provide a liaison between the students and academic departments and student services. The variety of leadership positions allows for different levels of involvement so that students can balance their academic and extracurricular loads effectively.

The political and practical leadership skills that students develop through the ASB are supplemented through a leadership course offered through the Political Science and Psychology Departments (POLS 27; PSYC 27). The curriculum includes practical skills that are applicable to college-related opportunities and other professional and personal environments. The curriculum is an interdisciplinary approach to contemporary leadership. This is an elective course that is transferrable to the CSU system and meets a GE requirement for the Gavilan College A.A./A.S. degree. Although the UC system does not accept the units for the class, it gives added consideration to those students who have been involved in student government and other college governance activities. Employers also look favorably upon a student's involvement in college leadership.

ASB CARDS: The benefits of buying a student body card are many. Revenue supports social and cultural activities on campus and provides the purchaser with discounts at athletic and cultural events and free bluebooks and scantrons (testing supplies) in the bookstore. Many businesses in Gilroy, Morgan Hill and Hollister offer discounts to card holders. Visit the ASB office in the Student Center - room 158 or call 408-848-4777.

Publications

The Gavilan Press, an independent student newspaper, has provided students with a real world journalism experience and a public forum for their ideas and opinions since 1967. The newspaper covers events, issues and people that shape, reflect and define the college and the world. The Gavilan Press is also available online. Go to www.gavilanpress.com. Call 408-848-4837 for more information.

The **Gavilan College Literary Journal** provides a forum for creative writers, helping to model and sustain the practice of writing poetry and prose. For more information call the Writing Center at 408-848-4811 or Scott Sandler at 408-846-4979.

Rho Alpha Mu - Honor Society Rho Alpha Mu is the Gavilan College chapter of Alpha Gamma Sigma, the California Community College Honor Scholarship Society. Its purpose is to recognize student scholarship, contribute to the social and cultural life of the campus and to provide and promote active involvement with the larger community through voluntary community service activities. Membership is open to all those with at least a 3.0 grade point average. There are a number of financial award possibilities for members in good standing. For more information call 408-846-4947.

Theatre Productions

The Monday Night Series presents staged readings of new, controversial or unusual material free of charge at 6:30 Monday evenings in the Gavilan College Theatre. For more information call (408) 848-4860 .

The **Summer Theatre Arts Repertory (STAR)** summer program trains children in dramatic performance. Students from the academic program serve as STAR leaders, often directing and producing plays for themselves. The Theatre program provides academic credit, production experience, and the opportunity for individual growth through the arts. For more information call 408-848-4764 or visit www.gavilan.edu/star.

The Gavilan College Theatre offers a range of plays, including childrens' plays, musicals and Shakespearean productions. In addition to performing on stage, students learn backstage and technical production skills. For more information visit www.gavilan.edu/theatre.



ASB CLUBS

For more information call 408-848-4777.

- Ambassadors
- Aneme
- Chi Sigma Lota
(Administration of Justice)
- Cheerleading
- CDC Parenting Club
- Club BYU
- COSMO
- Digital Media
- EOPS
- Gavilan Music
- Gavilan Pre-Health Club
- Health Promotion
- GavTV
- Inception Literary Club
- International Club
- Latina Leadership Network
- MANO (Men's Academic Network Organization)
- MESA (Math Engineering Science Achievement)
- OUT
- Parent's Club
- Rho Alpha Mu
- TADA/Theatre Arts
- Teachers For Tomorrow
- The Gavilan Press/Student Newspaper



A variety of clubs and organizations have been established to provide opportunities for students to participate in scholastic, social, political, cultural and recreational pursuits. Club activities are coordinated and supported through the Student Senate. Students are encouraged to start clubs if they have a particular interest not represented currently on campus.

Policies and Procedures

College policies and procedures are available by accessing the Gavilan College website at www.gavilan.edu or by visiting the office of the Vice President of Student Services (SC130).

Academic Freedom It shall be the policy of the College to maintain and encourage full freedom for its faculty to teach, research and pursue knowledge subject to the applicable provisions of law.

In the exercise of this freedom the faculty member may, as provided in the U.S. and California Constitutions and other applicable laws, discuss his/her own subject or area of competence in the classroom, as well as any other relevant matters, including controversial matters, so long as he/she distinguishes between personal opinions and factual information.

Faculty shall be free from unlawful harassment or from unlawful interference or restrictions based on political views.

Faculty shall be free from any and all forms of electronic or other listening or recording devices, except with his/her express and non-continuing consent, except where allowed otherwise by law.

The Board shall not unlawfully inquire into, nor predicate any adverse action upon a faculty member's personal, political or organizational activities or preferences.

The Board shall not interfere with a faculty member's freedom of speech or use of materials in any teaching assignment, except as allowed by law.

The intent is to allow those activities protected by constitutional freedom of speech and other forms of academic freedom protected by the laws of the State of California and the laws of the United States.

Disabilities

AMERICAN'S WITH DISABILITIES ACT (ADA) COMPLIANCE: If you have a verified disability and need academic materials in an alternate format or other services, contact the Disability Resource Center or the Vice President of Student Services for assistance.

RESOURCES FOR STUDENTS WITH DISABILITIES: Students requiring academic or physical accommodations because of visual, physical, learning and/or other verified disabilities should contact the Disability Resource Center at 408-848-4865.

Discrimination

PROHIBITION OF HARASSMENT AND HATE CRIMES (Reference: Education Code sections 212.5; 66252; 66281.5): The District is committed to providing an academic and work environment that respects the dignity of individuals and groups. The District shall be free of sexual harassment and all forms of sexual intimidation and exploitation. It shall also be free of other unlawful harassment and hate crimes, including those which are based on any of the following statuses; race, color, religion, ancestry, national origin, disability, sex (i.e., gender), sexual orientation, or the perception that a person has one or more of the foregoing characteristics.

NON-DISCRIMINATION: The district is committed to equal opportunity in educational programs, employment, and all access to institutional programs and activities.

Drug Free Schools and Campuses Act District Policy AP 3550 prohibits "the use, distribution, sale or possession of alcohol, narcotics, dangerous or illegal drugs or other controlled substances, as defined in California statutes, on District property or at any function sponsored by the District." Gavilan College complies with the Drug-Free Schools and Campuses Act of 1989 and the Drug-Free Workplace Act of 1988.

The college recognizes the legal drinking age of 21 years and enforces all state laws regulating the use of alcoholic beverages. All members of the campus community are subject to disciplinary action and/or criminal prosecution for the on-campus

possession, use, sale or distribution (by either sale or gift) of any quantity of inappropriate prescription drugs, or controlled substances as defined by the State of California Health and Safety Code. Students found to be in violation of this policy may be subject to the Standards of Student Conduct and Discipline Procedures. If warranted, employees will also be subject to disciplinary sanction.

For Free Confidential Assistance:

On-Campus:

- Counseling Center, 408-848-4723
- Student Health Services, 408-848-4791

Off-Campus:

- Alcoholics Anonymous, 408-374-8511; www.AASanJose.org
- Narcotics Anonymous, 408-998-4200
- National Council on Alcoholism & Drug Dependence 408-292-7292

Further detailed information on the risks associated with the use of alcohol and other drugs may be obtained from the Gavilan College website: www.gavilan.edu. Click on Drug Free Schools and Campus Act of 1989 and the Drug Free Workplace Act of 1988.

Health Consequences:

- Impaired learning due to poor concentration, fatigue, drowsiness, anxiety, altered perception, confusion, indifference, depersonalization, memory loss, panic attacks and drug-induced psychosis.
- Impaired judgment leading to driving under the influence of alcohol/other drugs, accidents, violent and abusive behavior, criminal acts, financial troubles, unwanted pregnancy, sexually transmitted diseases, acquaintance rape, attempted or accomplished suicide, permanent injury or death as a result of substance overdose.
- The use of intravenous drugs can result in hepatitis, tetanus, abscesses, and AIDS.
- The use of stimulants can lead to cardiac fibrillation, heart attack, seizures, respiratory arrest and death.
- The most common negative health consequences from occasional drinking are trauma incidents such as auto accidents and violent behavior which involve both the drinker and non-drinking victims.
- Long-term alcohol abuse can cause brain damage, cirrhosis of the liver, hepatitis, permanent coordination loss, ulcer disease, gastritis, pancreatitis, heart disease, stroke, anemia, sexual dysfunction, cancers and many other health problems.

Legal Sanctions:

As a student, if you are under the influence of alcohol and/or other drugs, or if you are discovered selling or dispensing drugs on campus or at any college function, you can be suspended, expelled and criminally prosecuted.

If you are an employee at Gavilan College, you may be placed on probation, terminated and criminally prosecuted for the use, sale or possession of illegal drugs and/or alcohol on campus, or at college sponsored events.

For a first offense of driving under the influence of alcohol and/or drugs, you may serve 96 hours to six months in jail and pay a fine. It is unlawful for anyone with a blood alcohol content (BAC) level of .08 percent or above to drive a motor vehicle or ride a bicycle on a highway. For pot or marijuana (1 oz. or less), you can be fined up to \$100 and receive a criminal citation.

- For possession of marijuana (more than 1 oz.) you may receive up to 6 months in county jail, up to a \$500 fine, or both.
- For possession of cocaine you can be imprisoned in a state prison.
- For sales of any illegal drug you can be imprisoned in a state prison.

- Any person under the age of 21 years who has any alcoholic beverage in his or her possession on any street or highway or in any public place can be convicted of a misdemeanor.
- It is a misdemeanor crime to sell, give or furnish alcohol to anyone under 21 years of age.
- Carriers of motor vehicle insurance can increase premiums, cancel or deny renewal as a result of driving-under-the-influence convictions.

Family Educational Rights and Privacy In compliance with the Federal Family Education Rights and Privacy Act of 1974 (also known as the Buckley Amendment) and California Title V regulations (SB 182), Gavilan has adopted the following policy:

- Official academic, discipline and other necessary records are maintained on all students who have applied to attend Gavilan College.
- These records are maintained by and in the Admissions & Records Office and the Office of the Vice President of Student Services.
- These records will be released only upon the written authorization of the student upon payment of any or all fees and charges due the college, except as provided by law. Unless otherwise directed, the following directory of information may be released by Gavilan without written consent of the student:
 - name of the student
 - dates of attendance at Gavilan
 - date of graduation and degree or certificate awarded

Students who do not wish to have the above information released as directory information may notify the Admissions & Records Office in writing within the first week of each term. Copies of the complete federal and state regulations are available in the Vice President of Student Services Office and may be reviewed by students by appointment.

Open Enrollment Unless specifically exempted by statute, every course, course section or class, the average daily attendance of which is to be reported for state aid shall be fully open to enrollment and participation by any person who has been admitted to the college and who meets all prerequisites. Class enrollment is limited by size of facility and program content. Gavilan College is in compliance with Section 504 of the Rehabilitation Act of 1973 and the Americans with Disabilities Act of 1990.

Parking on Campus Semester permits are available during all registration periods. All vehicles parked on the main campus are required to display a parking permit. Day permits are available from coin-operated machines located in parking lots A, E and at the south entrance to campus. Student parking is permitted in Lots A, C, E or H except where restricted to staff, guests, or the disabled. Parking Lot D is reserved for staff and disabled only. Guest parking permits are issued at the switchboard in Administration building. Disability parking is available in all lots to those displaying a placard from the Department of Motor Vehicles.

Student and staff parking is enforced by the campus security department and local law enforcement: Mon - Thurs: 7am-10 p.m and Fri: 7 am- 5 pm. All other spaces and areas are enforced at all times. A complete list of parking regulations is available at the main switchboard/reception area and outside the security office.

Sexual Assault Sexual assault is a crime regardless of when or where it occurs, or what the relationship is between the attacker and the victim. Gavilan College is committed to providing a safe environment for students and staff. Reports of sexual misconduct will be thoroughly investigated and the victim informed of the outcome.

If you, or someone you know, have been the victim of sexual assault, notify Campus Security 408-848-4703 or 408-710-7490. Confidential counseling is available on campus through Counseling (848-4723) or Student Health Services 408-848-4791.

Off campus confidential counseling is available at Community Solutions: 408-779-2115 and 831-637-SAFE (831-637-7233).

Smoke-Free Buildings (BP 6500) Smoking is prohibited inside all public buildings, within twenty 25 feet of all entrances/exits, operable windows or ventilation air intake. Smoking is also prohibited in all college-owned vehicles. Tobacco products shall not be sold on campus either through vending machines or campus establishments. Implementation of the campus smoke-free environment policy will be the responsibility of every student, faculty member, staff person and visitor on campus.

Students' Problem Resolution Process Procedures have been adopted to allow for student grievances against Gavilan staff members. The formal policy is available through the Vice President of Student Services Office, in the college catalog and on the Gavilan College website, www.gavilan.edu. Students are encouraged to resolve issues informally by talking with college staff members.

Title VI, Title IX, and ADA/Section 504/508 To file complaints in the following areas please contact the Equal Opportunity Officer, Joseph D. Keeler, Vice President of Administrative Services, HR101 (408-848-4731). or Shairon Williams, Director of Human Resources, HR103 (408-848-4753).

The areas are:

- Civil rights complaints (Title VI)
- Gender equity, sex discrimination/harassment complaints (Title IX)
- Persons with disabilities discrimination complaints (ADA/Section 504/508)

Vocational English Skills Limited English language skills will not be a barrier to admission to and participation in vocational education programs.

Gavilan's Grade Policy

Grade	Grade Points	Definition
A	4	Excellent
A-	3.7	Excellent
B+	3.3	Good
B	3	Good
B-	2.7	Good
C+	2.3	Satisfactory
C	2	Satisfactory
D	1	Passing, Less Than Satisfactory
F	0	Failing
P*	0	Pass - at least satisfactory, units awarded not counted in grade point average or in consideration of honors.
NP*	0	No Pass - less than satisfactory or failing, units not counted in grade point average.
I	0	Incomplete - incomplete academic work for unforeseeable, emergency and justifiable reasons after the last day to withdraw with a "w". Request for this grade must be initiated by the student. Work to be completed must not involve further class attendance or instruction. The Incomplete must be made up during the next term of attendance, summer excluded, within the next year.
W	0	Withdrawn - withdrew from class after the NRS (No Record Shown) period and before the W deadline. Students withdrawing from courses after the W deadline must be awarded a letter grade or, if appropriate, request an incomplete (see above.)
MW	0	Military Withdrawal

* To be used ONLY if final grade for a course is designated Credit/No Credit

ESL (English as a Second Language)

New students who want to take ESL classes at the Gilroy campus will register at the Admissions & Records Office for a placement assessment appointment when completing an application. Call 408-848-4737 or 408-848-4751 to make an appointment or come into Admissions & Records at the Gilroy main campus.

Students interested in taking ESL courses in Hollister should contact Judy Rodríguez at (831) 636-3783 or go to the Briggs Building in Hollister to schedule an assessment appointment.

Who Should Take the ESL Assessment?

- Students who do not know any English.
- Students who know some English but have not received formal classes in the English language or who took ESL classes more than three years ago.
- Students who attended high school in this country for less than a year.
- Students who attended high school in this country for a few years but are unsure about their level of proficiency in English.



Placement Assessment and Orientation for ESL Applicants

Students who want to enroll in ESL classes must:

- Complete a Gavilan College application at Admissions & Records or at the sites.
- Sign up for a testing appointment at Admissions & Records (Gilroy).
- Return for testing, which includes oral and written exams.

The interview information and the test results will be used to advise and place students into the ESL classes that best match their needs. Students will be ready to register for ESL classes at the end of this three-hour placement assessment appointment.

Orientation for new ESL students will be offered several times during the first two weeks of the semester and will be given in English and Spanish in the classroom setting. New students will be contacted for orientation by their ESL instructors.

Para información sobre clases de ESL, refiérase a la página 83.

Revise las clases 501 y 502 (cursos intensivos) ofrecidos en Hollister por la mañana. Refiérase a la página 81-82.

Para información sobre clases de destrezas básicas, refiérase a las páginas 81-82 (ENGL 420, 439, 440) y página 94 (MATH 400, 402).

Nunca es tarde para obtener su GED. Revise éste curso GRATIS en la página 113.

¿Necesita refrescar un poco sus habilidades de inglés para poder comunicarse con sus compañeros de trabajo? Revise ésta clase GRATIS de Inglés Vocacional en la página 113.

ESL (Inglés como Segunda Lengua)

Los nuevos estudiantes que deseen tomar clases de Inglés como Segunda Lengua (ESL) en Gilroy deben inscribirse en la Oficina de Admisiones y Archivos para hacer una cita y tomar la evaluación apropiada después de llenar una solicitud. Llame 408-848-4737 o 408-848-4751 hacer una cita o venga a la Oficina de Admisiones y Archivos en Gilroy.

Aquellos estudiantes que desean estudiar en Hollister deben hacer una cita para tomar el examen de nivelación en la oficina en Hollister en el Briggs Building o llamar al 831-636-3783.

¿Quién debería tomar el examen de evaluación de ESL?

- Los estudiantes que no saben nada de inglés.
- Los estudiantes que saben un poco de inglés pero que no han tomado clases formalmente o que tomaron clases hace más de tres años.
- Los estudiantes que asistieron a la secundaria (high school) en este país por menos de un año.
- Los estudiantes que asistieron a la secundaria (high school) en este país por algunos años pero que no están seguros de su nivel de proficiencia en el inglés.

Asesoramiento, Colocación y Orientación para Estudiantes ESL

Los estudiantes que deseen inscribirse en clases de ESL (Inglés como Segundo Idioma) deben hacer lo siguiente:

- Completar una solicitud de admisión en la Oficina de Admisiones y Archivos.
- Obtener una cita para el examen de nivelación en la Oficina de Admisiones y Archivos (Gilroy).
- Presentarse al examen de nivelación de acuerdo con la cita obtenida para tomar el examen escrito y oral.

Los resultados del examen y la información de la entrevista serán usados para recomendar y colocar a los estudiantes en las clases de Inglés como Segunda Lengua (ESL) que mejor les convengan. Los estudiantes estarán listos para inscribirse en las clases adecuadas al final de esta evaluación de tres horas. Los nuevos estudiantes en el Programa de Inglés como Segunda Lengua (ESL) recibirán una orientación sobre los servicios y regulaciones del Colegio Gavilán en sesiones ofrecidas durante las primeras dos semanas del semestre. Las orientaciones serán dadas en inglés y en español y los maestros se comunicarán con los nuevos estudiantes para asistirlos en seleccionar la sesión más conveniente.

¿Necesita ayuda para comprar libros?



Si usted ya compro su tarjeta de Cuerpo Asociado de Estudiantes (ASB) usted podrá aplicar para prestamos (maximo \$300) para comprar libros, en la Oficina de Ayuda Financiera, cuarto SC124.

Usted puede comprar la tarjeta de ASB en la Oficina de Admisiones y Archivos, cuarto SC 111.

Información en Español

La Misión

En un ambiente que fomenta creatividad y curiosidad intelectual, Gavilán "College" sirve a la comunidad ofreciendo experiencias de enseñanza de alta calidad y preparación para educación más avanzada, carreras técnicas y para servicio público, educación para toda la vida, y participación en una sociedad diversa y global.

Polizas y Procedimientos

Pendiente a la Mesa Directiva. La Política y Procedimientos del Colegio están disponibles a través de acceder la página de Internet del Colegio Gavilan en www.gavilan.edu (Seleccione el "College Catalog" bajo el menú de "Academics.") o visitando la Oficina del Vicepresidente de servicios Estudiantiles (SC130).

Formas Alternativas El Catalogo y el Horario de Clases del Colegio Gavilán está disponible en formato de medios alternos.

Por favor de contactar El Centro de Recursos para Estudiantes con Incapacidades en (408) 848-4865 o la Oficina del Vicepresidente de Servicios de Estudiante en (408) 848-4738.

Servicios para los Estudiantes con Incapacidades

Los estudiantes que requieren servicios o arreglos especiales debido a incapacidades auditivas, visuales o alguna otra incapacidad verificado deberán ponerse en contacto con su instructor, consejero, asesor El Centro de Recursos para Estudiantes con Incapacidades.

No Discriminación El Distrito está comprometido a proveer igualdad de oportunidades en programas educativos, empleo, y acceso a programas y actividades de la institución.

Prohibición de Abuso y Ofensas por Discriminación

Referencia: Secciones 212.5; 66252; 66281.5 del Código Educativo

El Distrito está comprometido a proveer un ambiente de enseñanza y de trabajo que respete la dignidad de los individuos y grupos. El Distrito estará libre de ofensa y persecución sexual y todas la formas de intimidación sexual y abuso. También estará libre de otros abusos y ofensas por discriminación incluyendo aquellas ofensas basadas en cualquiera de los siguientes estados: raza, religión, ancestro, origen, impedimento, sexo (género), orientación sexual, o la percepción de que una persona tenga alguna de las características mencionadas.

Cumplimiento de ADA Si usted tiene un impedimento verificado y necesita materiales o servicios de estudio en un formato alterno, contacte El Centro de Recursos para Estudiantes con Incapacidades (DRC) o al Vicepresidente de Servicios Educativos para obtener ayuda. Hay servicios para estudiantes con impedimentos verificados a través de DRC o a través del Vicepresidente de Servicios Educativos.

Derechos Educativos y Privacidad Gavilan College está en cumplimiento de los Derechos Educativos Federales y Acto de 1974 (también llamado el Buckley Amendment) y las regulaciones del Título V de California (SB 182). Las siguientes reglas están en efecto:

1. Toda la documentación académica, documentación relacionada con problemas

disciplinarios, y cualquiera otra documentación oficial es mantenida para todos los estudiantes que han solicitado admisión a Gavilan College.

2. La documentación oficial es mantenida por y localizada en la Oficina de Admisiones y Registros.
3. La documentación oficial será proveida únicamente cuando la solicitud o permiso sea hecha por escrito por parte del estudiante previo pago de cualquier cargo o costo a la institución, excepto en los casos provistos en ley.
4. La siguiente información puede ser proveida por Gavilan College sin consentimiento escrito por parte del estudiante:
 - a. el nombre del estudiante
 - b. las fechas de matriculación/asistencia a Gavilan College
 - c. la fecha de graduación y título o certificado recibido

La entrega de cualquier otra información requerirá consentimiento escrito del estudiante, excepto en los casos provistos en ley. Los estudiantes pueden notificar su deseo por escrito a la Oficina de Admisiones y Registros durante la primera semana de cada sesión de estudios que no desean que los puntos ennumerados en a), b) y c) pueden ser entregados.

5. Los estudiantes tienen derecho a revisar sus propios archivos y la documentación que esté en ellos. Cualquier objeción a éstos archivos debe ser presentada por escrito al Vicepresidente de Instrucción y Servicios al Estudiante. Las objeciones serán resueltas por dicho vicepresidente, y la resolución será inserta en el archivo del estudiante pero no entregada con el resto de la documentación. En caso de desacuerdo sobre éste punto, la Política de Quejas de la institución estará en efecto.

Copias de las regulaciones federales y estatales y del Proceso de Resolución de Problemas Estudiantiles son disponibles a través de la Oficina de Admisiones y Registros y pueden ser revisadas por los estudiantes haciendo una cita con el Vicepresidente de Instrucción y Servicios Estudiantiles o el Director de Admisiones y Registros. El Proceso de Resolución de Problemas Estudiantiles también está disponible en éste catálogo, online, y en el Manual Estudiantil.

Habilidad en Inglés para Estudios Vocacionales

Habilidad limitada en Inglés no será obstáculo para ser admitido y participante en programas educativos vocacionales.

Título VI, Título IX, y Norteamericanos con Impedimento/Sección 504/508

Para presentar una queja en cualquiera de las siguientes areas, por favor comuníquese con el Oficial de Igualdad de Oportunidades, Joseph D. Keeler, Vicepresidente de Servicios Administrativos, HR 101 (408-848-4731) o Shairon Williams, Director de Recursos Humanos, HR103 (408-848-4753).

Las areas son las siguientes: quejas por violación de derechos civiles (Título VI), quejas por violación de igualdad de género, discriminación sexual, o abuso (Título IX) y quejas por violación contra personas con impedimentos (ADA/Sección 504/508)

Programa de No-Credito

Clases de No-Credito son ofrecidas y diseñadas para responder a las necesidades específicas e intereses de aquellos estudiantes que no desean obtener créditos por unidades. Estas clases ofrecen oportunidades para mejorar en materias, crecimiento del desarrollo, poder aprender ocupaciones y para aprender otras áreas de educación general. Estos cursos y programas están definidos categóricamente bajo el Código de Educación, Sección 84711, mientras que los fondos del estado se permiten en nueve categorías específicas.

Programa para Personas Mayores - Este programa ofrece clases de interés especial para adultos mayores de 55 años de edad. La mayoría de nuestras clases se llevarán a cabo en lugares de reuniones de adultos mayores con el fin de promover una inscripción satisfactoria y facilidad para dichos estudiantes.

Programa para el Bienestar del Personal - Este programa está diseñado para responder a las necesidades de los adultos que trabajan. Las clases están abiertas para todos los miembros del personal y de la comunidad.

Programa de Educación Básica Para Adultos - Este programa esta diseñado para adultos que desean tomar clases de Ingles como Segunda Lengua (ESL). Ofrecemos clases para preparación de Ciudadanía, clases para mejorar sus habilidades en lectura, escritura, y matemáticas. El programa también ofrece clases para los estudiantes que están interesados en preparación de Educación General (GED) y CAHSEE (Examen de Egreso de las Preparatorias de California).

Todas las clases son gratuitas. No se requieren pruebas, exámenes ni tampoco se otorgan calificaciones. Las inscripciones se realizan a través de la Oficina de Admisiones y Archivos o en el lugar en donde se vaya a impartir la clase, durante la primera sesión de la clase. Los estudiantes deben de contactar directamente a la Oficina de No-Credito si tienen preguntas o si necesitan más información, favor de llamar al (408) 848-4859.

Servicios Estudiantiles y Programas de Apoyo para la Instrucción

Servicios de Asesoría Inscribirse y tener éxito en clases a nivel post-secundario requieren dedicación y tiempo. A veces ocurren problemas personales y familiares que distraen a los estudiantes de sus tareas y clases y en estos casos, la única solución parece ser abandonar los estudios. Antes de tomar esta decisión tan difícil, por favor consulte a un consejero. Una buena plática puede ayudar a poner la situación en perspectiva, identificar posibles soluciones, y dar el apoyo necesario para hacer modificaciones necesarias en el horario y las clases. Gavilán College provee consejeros que hablan español y las citas con ellos pueden ser hechas para el día o para la tarde. No hay que pagar por este servicio. Por favor llame al 408-848-4723 para hacer una cita.

Centro de Desarrollo de Niños El Centro de Desarrollo de Niños provee cuidado para niños preescolares, en dos programas para familias con ingresos mensuales que satisfacen el criterio de elegibilidad. Estos programas sirven a niños con discapacidades y necesidades especiales y que no hablan inglés. Todos los programas requieren que los padres inviertan ciertas horas como voluntarios.

¿Necesita ayuda para comprar libros?



Si usted ya compro su tarjeta de Cuerpo Asociado de Estudiantes (ASB) usted podra aplicar para prestamos (maximo \$300) para comprar libros, en la Oficina de Ayuda Financiera, cuarto SC124.

Usted puede comprar la tarjeta de ASB en la Oficina de Admisiones y Archivos, cuarto SC 111.

El Centro de Recursos para Estudiantes con

Incapacidades El Centro de Recursos para Estudiantes con Incapacidades (DRC) ofrece asesoría individual para evaluar las destrezas de los estudiantes en las áreas de lectura, matemáticas, escritura, razonamiento, lenguaje oral, percepción y memoria. Los estudiantes que requieren servicios o arreglos especiales debido a incapacidades auditivas, visuales o alguna otra incapacidad deberán ponerse en contacto con su instructor, consejero, asesor o la oficina del DRC.

Servicios de Ayuda Económica para el Colegio

La ayuda económica para costos del colegio, están disponibles para estudiantes de cualquier tipo de ingreso.

OFICINA DE AYUDA ECONÓMICA

Oficina SC 124

Abierto: lunes-jueves: 8 a.m. a 5 p.m., viernes: 8 a.m. a 3 p.m.

Horario de la Tarde: Las horas son extendidas de 5 a 7 pm durante el período de matriculación.

CÓDIGO ESCOLAR DEL COLEGIO GAVILÁN ES: 001202

El colegio Gavilán participa en varios programas de ayuda económica, que están diseñados para proporcionar ayuda a los estudiantes de necesidad económica. Esta ayuda es proporcionada por diferentes instituciones incluyendo agencias federales, estatales y privadas.

Si está interesado en solicitar ayuda económica, adquiera una solicitud (FAFSA) en la oficina SC 124 o solicítela usando el Internet en la página www.fafsa.ed.gov. Si llena la solicitud usando el Internet, imprima y mande la página con su firma (signature page) o use su número secreto (PIN) para firmar la solicitud electrónicamente. Si desea aplicar para obtener su número secreto (PIN) ingrese a www.PIN.ed.gov. Las solicitudes también se pueden obtener por medio de los Consejeros de las Preparatorias (High School), Centro de Carreras de la Preparatoria y Bibliotecas Públicas.

Los requisitos para ayuda económica de parte de FAFSA son:

- Tienen que comprobar que necesitan ayuda económica y que cumplen con las reglas de cada programa.
- Tienen que ser ciudadanos, o ser residentes permanentes de los EE.UU.
- Tienen que tener buen historial en préstamos estudiantiles, y no deber nada a la oficina de ayuda económica.
- Tienen que ser elegibles para recibir los beneficios de una educación superior.
- Hombres entre 18 y 25 años de edad tienen que registrarse en el servicio selectivo (militar).

NOTA: Si ha estado encarcelado por usar o vender drogas ilegales, puede ser no elegible para algunos programas de ayuda económica.

PÓLIZA DE PROGRESO SATISFACTORIO ACADÉMICO (SAP)

La oficina de ayuda económica requiere medir su progreso académico hacia un certificado, asociado, o un programa de transferencia a la universidad. Si sus metas no son uno de estos programas, no califica para ayuda económica. Su progreso será evaluado por lo mínimo una vez por año.

Si ha sido descalificado, tiene que atender a la sección de (SAP). Vaya a la oficina de ayuda económica para que se registre.

PROGRAMAS DE AYUDA ECONÓMICA

Ayuda Pagando la Matriculación: El programa (Board of Governor's Fee Waiver/BOG), ayuda a pagar parte de la matriculación. Solamente para residentes de California. Es para estudiantes de bajo ingreso familiar. La solicitud para el BOG se encuentra en la página 139-140.

Becas Gratuitas Federales y Estatales:

- Federal Pell Grant
- Federal SEO Grant
- Cal Grant
- Chafee Grant
- Child Development Grant
- EOPS Grant
- TRIO Grant

Becas Federales de Trabajo y Estudio: Proporciona al estudiante la oportunidad de ganar dinero, mientras aumentan su experiencia de trabajo. Se proporciona la ayuda basándose en la necesidad del estudiante.

Becas Generales: La beca es otorgada basada en el mérito del estudiante y/o necesidad económica. Los requisitos varían y son proporcionados por el donador de la beca. Las solicitudes generales de becas en el Colegio Gavilán se vencen el 27 de Febrero. Becas adicionales tienen diferentes fechas de vencimiento durante el año escolar. Las solicitudes están disponibles en la oficina de ayuda económica. Se recomienda que pregunten sobre las becas varias veces por semestre, porque nuevas becas serán anunciadas en cuanto estén disponibles durante el año escolar.

Servicios Para Miembros de las Fuerzas Armadas (Veteranos): Colegio Gavilán ofrece asistencia especial a estudiantes que son veteranos o hijos de veteranos deshabilitados que asisten al colegio, para lograr una meta. Estudiantes que tengan preguntas sobre si califican, beneficios y el procedimiento de las solicitudes o cualquier otra inquietud sobre veteranos, por favor de contactar la oficina de ayuda económica al 408-848-4734.

Préstamos Estudiantiles Federales: Colegio Gavilán participa en el Federal Family Educational Loan Program. Préstamos estudiantiles federales, ofrecen un interés bajo y planes de pago flexibles. Si están interesados en solicitar un préstamo complete la FAFSA y atienda al taller de consejería de préstamo. Solicitudes para el préstamo serán distribuidas en el taller de consejería.

Becas Privadas: Becas privadas son fundadas por organizaciones y agencias privadas. Estos fondos se otorgan al estudiante dependiendo de las notas académicas o dependiendo de la necesidad económica del estudiante. Para ser considerado para una beca privada, el estudiante necesita completar una solicitud por cada beca privada a la que se aplique. Visite nuestra oficina para más información.

Solicitudes para la beca privada llamada "Gavilan College Scholarship Application" están disponibles en nuestra oficina.

VISÍTENOS EN LA PÁGINA DEL INTERNET A WWW.GAVILAN.EDU/FINAID

Complete la FAFSA en la página del Internet WWW.FAFSA.ED.GOV

Ayuda de planeamiento financiero y consejería de préstamos en la página WWW.EDWISE.ORG

Averigüe su estado de préstamo en la página WWW.ELMRESOURCES.COM

Regístrate para Servicios Selectivos en la página WWW.SSS.GOV

Aplique para su número de identificación personal (PIN) en la página WWW.PIN.ED.GOV

El Centro de Desarrollo Infantil del Colegio Gavilán

provee cuidado de niños hasta la edad de cinco años mientras que usted asiste a sus clases.

(408) 848-4815

Acreditado por NAEYC

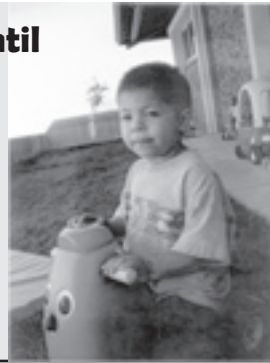
**EOPS**

Programas y Servicios de Oportunidad Adicional



La oficina de Programas y Servicios de Oportunidad Adicional (EOPS) provee apoyo a estudiantes que experi-

mentan desafíos económicos, sociales, y educativos. La intención del programa es asistir a estos estudiantes a alcanzar sus metas educativas incrementando el acceso, la retención, y la transferencia a otras instituciones de enseñanza. Para calificar para el programa de EOPS, los estudiantes deben demostrar necesidad financiera y educativa y matricularse en un mínimo de 12 unidades cada semestre.

Servicios y beneficios disponibles para estudiantes:

Consejería personal y académica, asistencia para la compra libros, prioridad de inscripción a clases, tutoría, paseos a universidades, talleres de enriquecimiento, becas y mucho más.

**CalWORKs**

CalWORKs está diseñado para asistir a estudiantes que reciben asistencia pública a ser auto-suficientes a través de obtener una educación, empleo y servicios de apoyo. El programa ocupacional para estudiantes CalWORKs responde a la demanda del mercado laboral y asiste a los estudiantes a lograr sus objetivos de carrera. Consecuentemente, el programa CalWORKs sirve de enlace con los departamentos de servicios sociales del condado de Santa Clara y San Benito.

Servicios y beneficios disponibles para estudiantes: Consejería académica y personal, asistencia para la compra de libros, asistencia laboral y de colocación en empleos.

Los programas de CalWORKs y EOPS están localizados en salón L101A. Para más información, llame al (408) 848-4740.

Major & Occupational **CODES**

Use these codes to complete question # 13 of the Gavilan College Application for Admission

Administration of Justice

Law Enforcement	210500
Academy	210550
Corrections	210510

Allied Health

Registered Nursing	123010
Vocational Nursing	123020

Business

Accounting	050200
Economics	220400
General Business	050600
General Office	050100
Medical Office	051420
Real Estate	051100

Child Development & Education

Child Development & Education	130500
Pre K-12 Special Ed Aide	080200

Communication

Communication, General	060100
Interpersonal Communication	493011

Computer Graphics & Design

Computer Graphics & Design	103000
----------------------------	--------

Computer Science & Information Systems

Business Computer Application, Hardware & Networking	070100
Comp Prep for Bioinformatics	070710
Programming	070710
Telecom Network Cabling	070700

Fine & Performing Arts

Art, General	100200
Fine Arts	100100
Music, General	100400
Technical Theatre	100600
Television	109900
Theatre Arts	100700

Letters

English as a Second Language	493080
Humanities	490300
Language Arts	493020

Liberal Arts

Liberal Arts	490100
--------------	--------

Media Arts

Digital Media	060100
Media Arts	060300

Sciences

Biological Science	040110
Education/Sports Medicine	122800
Health Science	083700
Mathematics	170100
Physical Science & Engineering	190100
Physical Education	083500

Social Sciences

Social Science, General	220100
-------------------------	--------

Spanish

Spanish	110500
---------	--------

Technical Trades

Aviation Maintenance	095000
Airframe	095010
Powerplant	095020
Cosmetology/Esthetician	300700
Special Careers	493030

Educational Support Services for Students with Disabilities

Completion of this form is optional. Any information you provide will be strictly confidential. Please return it to the Disability Resource Center (DRC) or the Admissions and Records Office at Gavilan College. For more information on available services, contact DRC at (408) 848-4865.

Name: _____
Last
First
Middle Initial

Address: _____
Street

City
State
Zip

Phone: _____

Please check any of the following that currently apply:

- | | | |
|-----------------------------------|--|---|
| <input type="checkbox"/> Mobility | <input type="checkbox"/> Speech | <input type="checkbox"/> Developmental Disability |
| <input type="checkbox"/> Visual | <input type="checkbox"/> Acquired Brain Injury | <input type="checkbox"/> Psychological Impairment |
| <input type="checkbox"/> Hearing | <input type="checkbox"/> Learning Disability | <input type="checkbox"/> Other |

Yes, I would like to be contacted regarding supportive services

METHOD B ENROLLMENT FEE WAIVER

10. **DEPENDENT STUDENT:** How many persons are in your parent(s)/RDP household? (Include yourself, your parent(s)/RDP, and anyone who lives with your parent(s)/RDP and receives more than 50% of their support from your parents/RDP), now and through June 30, 2009.) _____
11. **INDEPENDENT STUDENT:** How many persons are in your household? (Include yourself, your spouse/RDP, and anyone who lives with you and receives more than 50% of their support from you, now and through June 30, 2009.) _____

12. 2007 Income Information	DEPENDENT STUDENT: PARENT(S)/ RDP INCOME	INDEPENDENT STUDENT: STUDENT (& SPOUSE'S/ RDP) INCOME
a. Adjusted Gross Income (If 2007 U.S. Income Tax Return was filed, enter the amount from Form 1040, line 37; 1040A, line 21; 1040EZ, line 4).	\$ _____	\$ _____
b. All other income (Include ALL money earned in 2007 that is not included in line (a) above (such as TANF benefits, disability, Social Security, child support).	\$ _____	\$ _____
TOTAL Income for 2007 (Sum of a + b)	\$ _____	\$ _____

The Financial Aid Office will review your income and let you know if you qualify for an ENROLLMENT FEE WAIVER under Method B. If you do not qualify using this simple method, you should file a FAFSA.

SPECIAL CLASSIFICATIONS ENROLLMENT FEE WAIVERS

13. Do you have certification from the CA Department of Veterans Affairs that you are eligible for a dependent's fee waiver? *Submit certification.* Yes No
14. Do you have certification from the National Guard Adjutant General that you are eligible for a dependent's fee waiver? *Submit certification.* Yes No
15. Are you eligible as a recipient of the Congressional Medal of Honor or as a child of a recipient? *Submit documentation from the Department of Veterans Affairs.* Yes No
16. Are you eligible as a dependent of a victim of the September 11, 2001 terrorist attack? *Submit documentation from the CA Victim Compensation and Government Claims Board.* Yes No
17. Are you eligible as a dependent of a deceased law enforcement/fire suppression personnel killed in the line of duty? *Submit documentation from the public agency employer of record.* Yes No

If you answered "Yes" to any of the questions from 13-17, you are eligible for an ENROLLMENT FEE WAIVER and perhaps other fee waivers or adjustments. Sign the Certification at the below. Contact the Financial Aid Office if you have questions.

CERTIFICATION FOR ALL APPLICANTS: READ THIS STATEMENT AND SIGN BELOW

I hereby swear or affirm, under penalty of perjury, that all information on this form is true and complete to the best of my knowledge. If asked by an authorized official, I agree to provide proof of this information, which may include a copy of my and my spouse/registered domestic partner and/or my parent's/registered domestic partner's 2007 U.S. Income Tax Return(s). I also realize that any false statement or failure to give proof when asked may be cause for the denial, reduction, withdrawal, and/or repayment of my waiver. I authorize release of information regarding this application between the college, the college district, and the Chancellor's Office of the California Community Colleges.

Applicant's Signature _____ Date _____ Parent Signature (Dependent Students Only) _____ Date _____

California Information Privacy Act

State and federal laws protect an individual's right to privacy regarding information pertaining to oneself. The California Information Practices Act of 1977 requires the following information be provided to financial aid applicants who are asked to supply information about themselves. The principal purpose for requesting information on this form is to determine your eligibility for financial aid. The Chancellor's Office policy and the policy of the community college to which you are applying for aid authorize maintenance of this information. Failure to provide such information will delay and may even prevent your receipt of financial assistance. This form's information may be transmitted to other state agencies and the federal government if required by law. Individuals have the right of access to records established from information furnished on this form as it pertains to them.

The officials responsible for maintaining the information contained on this form are the financial aid administrators at the institutions to which you are applying for financial aid. The SSN may be used to verify your identity under record keeping systems established prior to January 1, 1975. If your college requires you to provide an SSN and you have questions, you should ask the financial aid officer at your college for further information. The Chancellor's Office and the California community colleges, in compliance with federal and state laws, do not discriminate on the basis of race, religion, color, national origin, gender, age, disability, medical condition, sexual orientation, domestic partnership or any other legally protected basis. Inquiries regarding these policies may be directed to the financial aid office of the college to which you are applying.

FOR OFFICE USE ONLY

<input type="checkbox"/> BOGFW-A <input type="checkbox"/> TANF/CalWORKs <input type="checkbox"/> GA <input type="checkbox"/> SSI/SSP	<input type="checkbox"/> BOGFW-B _____ <input type="checkbox"/> BOGFW-C	<input type="checkbox"/> Special Classification <input type="checkbox"/> Veteran <input type="checkbox"/> National Guard Dep <input type="checkbox"/> Medal of Honor <input type="checkbox"/> 9/11 Dependent <input type="checkbox"/> Dep. of deceased law enforcement/fire personnel	RDP <input type="checkbox"/> Student <input type="checkbox"/> Parent	<input type="checkbox"/> Not eligible due to: <input type="checkbox"/> Non CA resident
---	---	--	--	---

Certified by: _____ Date: _____



APPLICATION for ADMISSION

Summer ____

Fall ____ 2008

GAVILAN COLLEGE

1 SOCIAL SECURITY NUMBER ____ - ____ - ____	2 PLACE OF BIRTH State or County _____	BIRTHDATE Month Day Year _____
		3 GENDER 1 Male ____ 2 Female ____

4 NAME (As you wish it to appear on your records)

Last Name _____ First Name _____ Middle Initial _____

Current Mailing Address _____
Street

City _____ State _____ Zip _____

Phone (area code) _____ Name on Previous Gavilan Records _____

5 U.S. CITIZENSHIP ? Yes No	6 PRIMARY LANGUAGE
If not a U.S. citizen, indicate status below (check one) ____ 2 Permanent Resident: INS Number _____ Date Issued _____ ____ 3 Temporary Resident: INS Number _____ Date Issued _____	Is English your primary spoken language? Yes ____ No ____
____ 5 Refugee/Asylee ____ 6 Foreign Student (F-1) & 1-94 Expiration Date _____ ____ 7 Other Visa Type & I-94 Expiration Date _____	

7 PREDOMINANT ETHNIC BACKGROUND

10 White, Non-Hispanic	26 Vietnamese	43 South American	64 Other Pacific Islander	Enter Appropriate Number in Box <input style="width: 40px; height: 30px;" type="text"/>
21 Chinese	27 Indian Subcontinent	44 Other Hispanic	70 Filipino	
22 Japanese	28 Other Asian	50 American Indian, Alaskan	80 Other Non-White	
23 Korean	30 African-American	61 Guamanian	99 Decline to State	
24 Laotian	41 Mexican	62 Hawaiian		
25 Cambodian	42 Central American	63 Samoan		

8 ENROLLMENT STATUS

1 NEW, never attended any college
 2 NEW TRANSFER, attended college other than Gavilan
 3 RETURNING, last attended Gavilan but not last semester
 Date of last attendance at Gavilan: _____ Semester _____ Year _____

Enter Appropriate Number in Box

9 STUDENT EDUCATION STATUS (Highest level of education)

1 Not a graduate of, and no longer in High School	8 Received an Associate Degree	Enter Appropriate Number in Box <input style="width: 40px; height: 30px;" type="text"/>
2 High School Student (currently enrolled in grades 9-12)	9 Received a Baccalaureate or Higher Degree **	
3 Currently Enrolled in Adult School	* Year of High School Diploma <input style="width: 40px;" type="text"/>	
4 Received High School Diploma *	**Year Degree Conferred <input style="width: 40px;" type="text"/>	
5 Received GED or Certificate of Equivalency/Completion		
6 Received Certificate or High School Proficiency Exam		
7 Foreign High School Graduate		

10 EDUCATIONAL GOALS

1 Personal Interest, not for employment	8 Job Skills, to Prepare for a New Job/Career	Enter Appropriate Number in Box <input style="width: 40px; height: 30px;" type="text"/>
2 Transfer to a 4-year College WITH AA, AS Degree	9 Enhance Present Job Skills	
3 Transfer to a 4-year College WITHOUT AA, AS Degree	10 Maintain Certificate or License (e.g., Nursing)	
4 Associate Degree, General Education	11 Improve Basic Skills in English, Reading, or Math	
5 Associate Degree, Vocational	12 Complete Credits for High School Diploma or GED	
6 Vocational Certificate	13 Undecided on Goal	
7 Discover/Formulate Career Interests, Plans, Goals		

11 HIGH SCHOOL LAST ATTENDED

____ 433395 Live Oak	____ 353650 San Benito Evening	____ 433363 Lick (James)	____ 273455 Salinas
____ 433448 Central	____ 353002 San Andreas Continuation	____ 273317 North Salinas	____ 433002 Santa Teresa
____ 433283 Gilroy	____ 353006 Anzar	____ 274405 Notre Dame (Salinas)	____ 433790 Silver Creek
____ 433279 Gilroy Adult	____ 433008 Gunderson	____ 433520 Oak Grove	____ 443790 Watsonville
____ 433485 Mt. Madonna	____ 433299 Hill (Andrew)	____ 433542 Overfelt (Wm. C.)	____ 433895 Willow Glen
____ 353700 San Benito Joint Union	____ 433352 Leland	____ 274413 Palma	____ 010236 Ann Sobrato

Name & Location of High School if not Listed Above _____

12 COLLEGES ATTENDED (List last college attended first)

College: _____	City _____	State _____	Dates: from _____ to _____
College: _____	City _____	State _____	Dates: from _____ to _____

13 MAJOR 	14 DIRECTORY INFORMATION No personal data other than directory information will be released without your written consent.	15 HOURS WORKED Approximate number of hours per week you will be employed during the semester. <input style="width: 40px;" type="text"/>	16 RE-ENTRY Check here if you have not attended any school for five or more years <input style="width: 40px;" type="text"/>
---------------------	---	--	---



STATEMENT OF LEGAL RESIDENCE

Name _____ SSN _____
Address _____
City _____ State _____ Zip _____ Date of Birth _____

PART A

To Be Completed By All Applicants

Have you lived in California for the past two years?

Yes ____ If you answered "Yes" and you are unmarried and under the age of 19, go to **Part B. Otherwise, skip to Part D.**

No ____ If you answered "No", complete the following:

- Date present stay in California began _____
- Do you intend California to be your permanent residence? Yes ____ No ____
- Date present stay in California began _____
- Did you file California State Income Tax for the last two years? Yes ____ No ____
- Are you a public school credentialed employee? Yes ____ No ____
- Are you a seasonal agricultural employee or dependent? Yes ____ No ____

- Drivers License or ID Card State: _____ Date Issued: _____
- Registered to Vote? State: _____ Date Registered: _____
- Vehicle Registration? State: _____ Date Issued: _____
- Other Proof of Residency in California _____

- List states lived in for the last two years and the dates:
State: _____ from _____ to _____
State: _____ from _____ to _____

PART B

To Be Completed About Your Parents or Legal Guardian If You Are Unmarried AND Under the Age of 19

I have lived continuously for the past two years with one or both of my parents and he/she/they have lived continuously for the past two years at the California address noted below:

Street _____ City _____ State _____

Yes ____ If "Yes", Check one: Both Parents ____ Mother ____ Father ____ Legal Guardian ____

No ____ If "No" and you wish to be considered a California resident, please complete the following about your parent(s) or legal guardian:

- Did they file California State Income Tax the last two years: Yes ____ No ____
- Does he/she/they have any of the following?
 - Driver's License or ID card State: _____ Date Issued: _____
 - Voter Registration? State: _____ Date Registered: _____
 - Vehicle Registration? State: _____ Date Issued: _____
 - Other Proof of Residency in California _____

PART C

To Be Completed by Active Military Persons, Dependents, or Veterans Discharged Within the Last Year

- Are you a member of the military? Yes ____ No ____
- Are you a dependent of an active military person? Yes ____ No ____
- When did your or your sponsor's tour begin in California? _____
- What is your state of legal residence on military records? _____

Note: Active duty military persons and/or dependents must provide a statement from the commanding officer stating the date of assignment and that the assignment to California is not for educational purposes. Dependents must also provide a letter stating that they are the dependent of a military person for the purposes of Federal Tax exemption.

PART D

To Be Signed by All Applicants

I declare under penalty of perjury that the statements submitted by me in connection with this application and for determination of residency are true and correct. All materials submitted by me for purposes of admission become the property of Gavilan College. I understand that falsification, withholding pertinent data, or failure to report changes in residence may result in my dismissal from the College.

Student's Signature

Date



• GAVILAN COLLEGE / HIGH SCHOOL CONTRACT FORM •

PLEASE READ CAREFULLY BEFORE PROCEEDING

- | | |
|---|---|
| <ul style="list-style-type: none"> ✓ Gavilan College accepts high school students whose cumulative grade point average is at least 2.00 for advanced (transfer level courses numbered 1-99) vocational, or physical education courses for the Fall and Spring Semesters. High School students may enroll for courses (numbered 1-499) during the summer session. ✓ A Gavilan application, placement assessment scores and current transcripts from the student's school are required before this form can be reviewed by a Gavilan counselor. | <ul style="list-style-type: none"> ✓ Students may enroll for a maximum of six units fall and spring semester, four units for summer. ✓ All course prerequisites are applicable. ✓ All credit earned at Gavilan College is "college" credit. ✓ A transcript of work completed at Gavilan will be sent to the recommending school at the end of the semester. ✓ High School contract students pay the per unit fee and provide their own texts and instructional supplies. ✓ All students shall conform to the college's academic rules, regulations, and codes of conduct. |
|---|---|

Student's Name _____ Security Number _____
LAST FIRST M.I.

Mailing Address _____
STREET CITY STATE ZIP

Tel # _____ Date of Birth _____ Last Grade Completed _____

Semester for which student is applying: Fall _____ Spring _____ Summer _____ 200 _____

• The Student's School Counselor/Designated School Official Recommends These Courses •

Specify recommended courses and units (Enrollment limited to courses numbered 1-99 except during the summer)

• Recommendations (Parent/Guardian, High School Official and Gavilan Counselor) •

1) Signature of Parent or Guardian _____ Date _____

In an emergency, contact _____
NAME TEL. #

2) Signature of Recommending School Official _____ Date _____

Name and Address of Recommending School _____

The recommendation of the school official signifies that the student is in good standing at his/her school, has a cumulative grade point average of at least 2.00, is eligible for continued enrollment, and has the ability and maturity to benefit from college-level instruction. A current transcript of the student's coursework must accompany this form.

2a) District Verification of "Home School" registration _____

3) **The signature of a Gavilan Counselor verifies the following:**

- The placement assessment was completed on (date) _____
- English Score _____ Math Score _____ DRC exemption? _____
- The recommended course is numbered 0 - 99 (summer term exempted).
- A current transcript from the student's school is attached and the student is in good standing.
- The cumulative high school grade point average is _____ (2.0 minimum required)

Gavilan College Counselor _____ Date _____



APPLICATION - Fall 2008

Name: _____ Social Security #: _____ - _____ - _____
 Address: _____ Phone: (_____) _____ - _____
 City: _____ Cell Phone: _____
 Zip Code: _____ Email: _____

*** Attach your high school transcript (must include senior year coursework.) ***

I would like to transfer to: _____ California State University _____ University of California
 _____ Private College/University _____ Not sure which system

Are you working while attending college? _____ Yes (# of hours per week _____) _____ No

Are you eligible for financial aid? _____ Yes _____ No _____ Don't Know

High School Graduate? _____ Yes _____ No _____ GED Year Graduated: _____

Name of High School: _____ City: _____ State: _____

Major: _____ Currently Undecided: _____

Please describe why you want to be part of the Transfer Institute: _____

For office use only	College Level: English 1A and Transfer Level Math:
Placement/Assessment Scores:	_____ Reading _____ Writing _____ Math

Intent to Register:

I agree to make a full commitment to the Transfer Institute. This commitment includes the following:

- Attend a required Welcome on **Tuesday, August 26, from 8:30 am-noon in SS 206 (Social Science building).**
- Sign a Transfer Institute agreement by **September, 2008.**
- Meet with a counselor three times per semester.
- Complete 30 transferable units in an Academic Year.
- Participate in Transfer Institute activities.

Student Signature: _____ **Date:** _____



IMPORTANT, PLEASE RETURN TO:
Gavilan College Counseling Department
5055 Santa Teresa Blvd.
Gilroy, CA 95020

MAIN CAMPUS, GILROY

5055 Santa Teresa Blvd.
 Gilroy, CA 95020
 408-848-4800 or
 831-637-1158 (from Hollister)

Key to Gavilan

Administration	SC
Admissions & Records	SC
Art Gallery	LI
Art Lecture	AL
ASB	SC
Assessment Center	BU
Athletics Office	GY/APE
Bookstore	SC
Business Office	BOB
Cafeteria	SC
CalWORKs	LI
Career/Transfer Center	SC
Cashier	BOB
Child Development Center	CD
Children's Preschool	CD
CMAP	LI
Community Ed	CJ
Computer Graphics & Design	LI
Counseling Offices	SC
Disability Resource Center	LI
Early College Academy	PB16-18
English/ESL (through July '08)	HU
(beg. Aug. '08)	PB
EOPS/Special Services	LI
Financial Aid Office	SC
Information/Switchboard	SC
Lounges, North and South	SC
Math Lab (through July '08)	PB14
(beg. Aug. '08)	PH101
MESA (through July '08)	PB15
(beg. Aug. '08)	PH115
Music	TH
Noncredit Program	PB2
Nursing	HOB
Payroll	BOB
Physical Education	GY/APE
Police Academy	OE
Public Information Office	PB2
ROP	BU
Security	S/M
Staff Resource Center	PB11N
Student Health Nurse	SC
Student Senate Office	SC
TRIO Program	SC
Tutoring Center Services	LI
TV Studio	LI

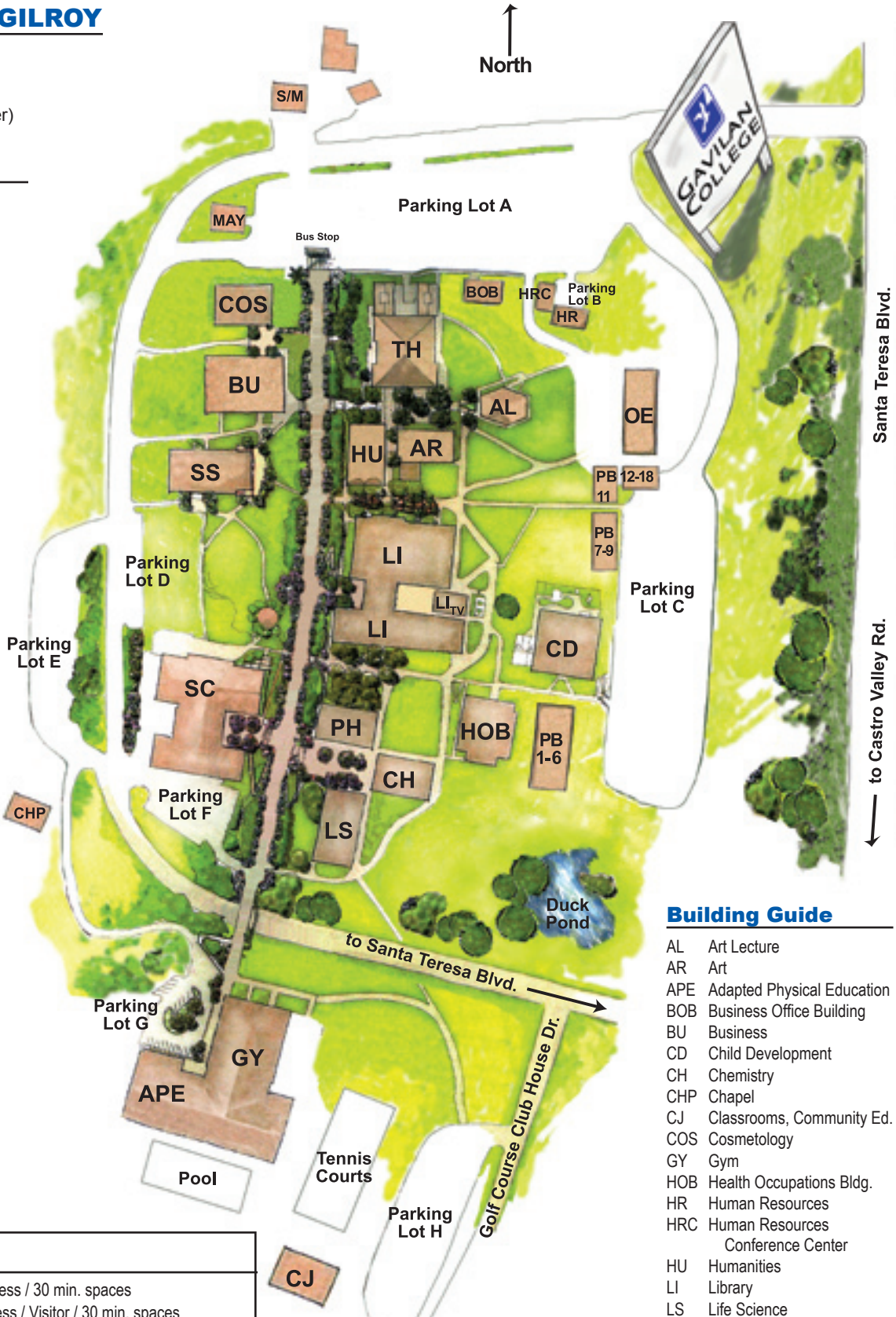

Building Guide

AL	Art Lecture
AR	Art
APE	Adapted Physical Education
BOB	Business Office Building
BU	Business
CD	Child Development
CH	Chemistry
CHP	Chapel
CJ	Classrooms, Community Ed.
COS	Cosmetology
GY	Gym
HOB	Health Occupations Bldg.
HR	Human Resources
HRC	Human Resources Conference Center
HU	Humanities
LI	Library
LS	Life Science
MAY	Mayock House
OE	Classrooms
PB	Portable Buildings
PH	Physical Science
SC	Student Center
S/M	Security/Maintenance
SS	Social Science
TH	Theater

Parking Lots

- A Student / Staff / Disabled Access / 30 min. spaces
- B Student / Staff / Disabled Access / Visitor / 30 min. spaces
- C Student / Staff / Disabled Access / 15 min. spaces / 30 min. spaces
- D Staff / Disabled Access
- E Student / Staff / Motorcycle
- F Staff / Disabled Access / Visitor / Motorcycle / 30 min. spaces
- G Staff / Disabled Access
- H Student / Staff / Disabled Access / Motorcycle / 30 min. spaces

DON'T GO TO THE WRONG CITY!
MHG = Morgan Hill
HOL = Hollister